

EXHIBIT A: PRICING PAGE
One (1) Compact Excavator

CONTRACT ITEM NO.	DESCRIPTION	QTY	UNIT PRICE	TOTAL
Item No. 3.1.1	Model E60 R2-Series Bobcat Compact Excavator, or Equal, with accessories and attachments.	1	\$ 131,000.00	\$ 131,000.00
	Manufacturer Bid: John Deere			
	Model No. Bid: 60P			
	Unit prices to be inclusive of all freight/delivery costs. Failure to use this form may result in disqualification.			Total Cost \$ 131,000.00
	Bidder / Vendor Information:			
	Name: Leslie Equipment Company			
	Phone: 304-204-1818			
	E-mail Address: maytrent@lec1.com			
	Authorized Signature: 	Date:	8-26-24	

RECEIVED
2024 AUG 26 AM 10:30
WW PURCHASING
DIVISION



Department of Administration
 Purchasing Division
 2019 Washington Street East
 Post Office Box 50130
 Charleston, WV 25305-0130

State of West Virginia
 Centralized Request for Quote

Proc Folder: 1486050			Reason for Modification:
Doc Description: One (1) Compact Excavator w/ Accessories and Attachments			
Proc Type: Central Purchase Order			
Date Issued	Solicitation Closes	Solicitation No	Version
2024-08-12	2024-08-26 13:30	CRFQ 0603 ADJ2500000014	1

BID RECEIVING LOCATION

BID CLERK
 DEPARTMENT OF ADMINISTRATION
 PURCHASING DIVISION
 2019 WASHINGTON ST E
 CHARLESTON WV 25305
 US

VENDOR

Vendor Customer Code:

Vendor Name: Leslie Equipment Company

Address: 19 Golf Crossing Drive

Street:

City: Cross Lanes

State: WV **Country:** US **Zip:** 25313

Principal Contact: Trent May

Vendor Contact Phone: 304-209-1818 **Extension:**

FOR INFORMATION CONTACT THE BUYER

David H Pauline
 304-558-0067
 david.h.pauline@wv.gov

Vendor Signature X *[Signature]* **FEIN#** 55-049-3180 **DATE** 8-26-24

All offers subject to all terms and conditions contained in this solicitation

ADDITIONAL INFORMATION

The West Virginia Purchasing Division is soliciting bids on behalf of West Virginia Army National Guard's, Environmental Protection Division at Camp Dawson in Kingwood, WV, to establish a contract for the one-time purchase of one (1) compact excavator with attachments and accessories.

INVOICE TO		SHIP TO	
ADJUTANT GENERALS OFFICE 1703 COONSKIN DR		CAMP DAWSON ARMY TRAINING SITE 240 ARMY RD	
CHARLESTON	WV	KINGWOOD	WV
US		US	

Line	Comm Ln Desc	Qty	Unit Issue	Unit Price	Total Price
1	One (1) Compact Excavator	1.00000	LS		

Comm Code	Manufacturer	Specification	Model #
22101526			

Extended Description:
 Contract Item 3.1.1. - Quantity of One (1) E60 R2-Series Bobcat Compact Excavator, or EQUAL, with accessories and attachments.

SCHEDULE OF EVENTS

<u>Line</u>	<u>Event</u>	<u>Event Date</u>
1	Vendor Technical Questions Due By 11:00 am., est.	2024-08-15

INSTRUCTIONS TO VENDORS SUBMITTING BIDS

1. REVIEW DOCUMENTS THOROUGHLY: The attached documents contain a solicitation for bids. Please read these instructions and all documents attached in their entirety. These instructions provide critical information about requirements that if overlooked could lead to disqualification of a Vendor's bid. All bids must be submitted in accordance with the provisions contained in these instructions and the Solicitation. Failure to do so may result in disqualification of Vendor's bid.

2. MANDATORY TERMS: The Solicitation may contain mandatory provisions identified by the use of the words "must," "will," and "shall." Failure to comply with a mandatory term in the Solicitation will result in bid disqualification.

3. PREBID MEETING: The item identified below shall apply to this Solicitation.

A pre-bid meeting will not be held prior to bid opening

A **MANDATORY PRE-BID** meeting will be held at the following place and time:

All Vendors submitting a bid must attend the mandatory pre-bid meeting. Failure to attend the mandatory pre-bid meeting shall result in disqualification of the Vendor's bid. No one individual is permitted to represent more than one vendor at the pre-bid meeting. Any individual that does attempt to represent two or more vendors will be required to select one vendor to which the individual's attendance will be attributed. The vendors not selected will be deemed to have not attended the pre-bid meeting unless another individual attended on their behalf.

An attendance sheet provided at the pre-bid meeting shall serve as the official document verifying attendance. Any person attending the pre-bid meeting on behalf of a Vendor must list on the attendance sheet his or her name and the name of the Vendor he or she is representing.

Additionally, the person attending the pre-bid meeting should include the Vendor's E-Mail address, phone number, and Fax number on the attendance sheet. It is the Vendor's responsibility to locate the attendance sheet and provide the required information. Failure to complete the attendance sheet as required may result in disqualification of Vendor's bid.

All Vendors should arrive prior to the starting time for the pre-bid. Vendors who arrive after the starting time but prior to the end of the pre-bid will be permitted to sign in but are charged with knowing all matters discussed at the pre-bid.

Questions submitted at least five business days prior to a scheduled pre-bid will be discussed at the pre-bid meeting if possible. Any discussions or answers to questions at the pre-bid meeting are preliminary in nature and are non-binding. Official and binding answers to questions will be published in a written addendum to the Solicitation prior to bid opening.

4. VENDOR QUESTION DEADLINE: Vendors may submit questions relating to this Solicitation to the Purchasing Division. Questions must be submitted in writing. All questions must be submitted on or before the date listed below and to the address listed below to be considered. A written response will be published in a Solicitation addendum if a response is possible and appropriate. Non-written discussions, conversations, or questions and answers regarding this Solicitation are preliminary in nature and are nonbinding.

Submitted emails should have the solicitation number in the subject line.

Question Submission Deadline: Thursday, August 15, 2024 by 11:00AM

Submit Questions to: David Pauline, Senior Buyer
2019 Washington Street, East
Charleston, WV 25305
Fax: (304) 558-3970
Email: david.h.pauline@wv.gov

5. VERBAL COMMUNICATION: Any verbal communication between the Vendor and any State personnel is not binding, including verbal communication at the mandatory pre-bid conference. Only information issued in writing and added to the Solicitation by an official written addendum by the Purchasing Division is binding.

6. BID SUBMISSION: All bids must be submitted on or before the date and time of the bid opening listed in section 7 below. Vendors can submit bids electronically through wvOASIS, in paper form delivered to the Purchasing Division at the address listed below either in person or by courier, or in facsimile form by faxing to the Purchasing Division at the number listed below. Notwithstanding the foregoing, the Purchasing Division may prohibit the submission of bids electronically through wvOASIS at its sole discretion. Such a prohibition will be contained and communicated in the wvOASIS system resulting in the Vendor's inability to submit bids through wvOASIS. The Purchasing Division will not accept bids, modification of bids, or addendum acknowledgment forms via email. Bids submitted in paper or facsimile form must contain a signature. Bids submitted in wvOASIS are deemed to be electronically signed.

Any bid received by the Purchasing Division staff is considered to be in the possession of the Purchasing Division and will not be returned for any reason.

For Request for Proposal ("RFP") Responses Only: Submission of a response to a Request for Proposal is not permitted in wvOASIS. In the event that Vendor is responding to a request for proposal, the Vendor shall submit one original technical and one original cost proposal prior to the bid opening date and time identified in Section 7 below, plus ^{N/A} convenience copies of each to the Purchasing Division at the address shown below. Additionally, the Vendor should clearly identify and segregate the cost proposal from the technical proposal in a separately sealed envelope.

Bid Delivery Address and Fax Number:

Department of Administration, Purchasing Division
2019 Washington Street East
Charleston, WV 25305-0130
Fax: 304-558-3970

A bid submitted in paper or facsimile form should contain the information listed below on the face of the submission envelope or fax cover sheet. Otherwise, the bid may be rejected by the Purchasing Division.

VENDOR NAME:

BUYER:

SOLICITATION NO.:

BID OPENING DATE:

BID OPENING TIME:

FAX NUMBER:

7. BID OPENING: Bids submitted in response to this Solicitation will be opened at the location identified below on the date and time listed below. Delivery of a bid after the bid opening date and time will result in bid disqualification. For purposes of this Solicitation, a bid is considered delivered when confirmation of delivery is provided by wvOASIS (in the case of electronic submission) or when the bid is time stamped by the official Purchasing Division time clock (in the case of hand delivery).

Bid Opening Date and Time: August 26, 2024, at 1:30 pm., est.

Bid Opening Location: Department of Administration, Purchasing Division
2019 Washington Street East
Charleston, WV 25305-0130

8. ADDENDUM ACKNOWLEDGEMENT: Changes or revisions to this Solicitation will be made by an official written addendum issued by the Purchasing Division. Vendor should acknowledge receipt of all addenda issued with this Solicitation by completing an Addendum Acknowledgment Form, a copy of which is included herewith. Failure to acknowledge addenda may result in bid disqualification. The addendum acknowledgement should be submitted with the bid to expedite document processing.

9. BID FORMATTING: Vendor should type or electronically enter the information onto its bid to prevent errors in the evaluation. Failure to type or electronically enter the information may result in bid disqualification.

10. ALTERNATE MODEL OR BRAND: Unless the box below is checked, any model, brand, or specification listed in this Solicitation establishes the acceptable level of quality only and is not intended to reflect a preference for, or in any way favor, a particular brand or vendor. Vendors may bid alternates to a listed model or brand provided that the alternate is at least equal to the model or brand and complies with the required specifications. The equality of any alternate being bid shall be determined by the State at its sole discretion. Any Vendor bidding an alternate model or brand should clearly identify the alternate items in its bid and should include manufacturer's specifications, industry literature, and/or any other relevant documentation demonstrating the equality of the alternate items. Failure to provide information for alternate items may be grounds for rejection of a Vendor's bid.

This Solicitation is based upon a standardized commodity established under W. Va. Code § 5A-3-61. Vendors are expected to bid the standardized commodity identified. Failure to bid the standardized commodity will result in your firm's bid being rejected.

11. EXCEPTIONS AND CLARIFICATIONS: The Solicitation contains the specifications that shall form the basis of a contractual agreement. Vendor shall clearly mark any exceptions, clarifications, or other proposed modifications in its bid. Exceptions to, clarifications of, or modifications of a requirement or term and condition of the Solicitation may result in bid disqualification.

12. COMMUNICATION LIMITATIONS: In accordance with West Virginia Code of State Rules §148-1-6.6, communication with the State of West Virginia or any of its employees regarding this Solicitation during the solicitation, bid, evaluation or award periods, except through the Purchasing Division, is strictly prohibited without prior Purchasing Division approval. Purchasing Division approval for such communication is implied for all agency delegated and exempt purchases.

13. REGISTRATION: Prior to Contract award, the apparent successful Vendor must be properly registered with the West Virginia Purchasing Division and must have paid the \$125 fee, if applicable.

14. UNIT PRICE: Unit prices shall prevail in cases of a discrepancy in the Vendor's bid.

15. PREFERENCE: Vendor Preference may be requested in purchases of motor vehicles or construction and maintenance equipment and machinery used in highway and other infrastructure projects. Any request for preference must be submitted in writing with the bid, must specifically identify the preference requested with reference to the applicable subsection of West Virginia Code § 5A-3-37, and must include with the bid any information necessary to evaluate and confirm the applicability of the requested preference. A request form to help facilitate the request can be found at: www.state.wv.us/admin/purchase/vrc/Venpref.pdf.

15A. RECIPROCAL PREFERENCE: The State of West Virginia applies a reciprocal preference to all solicitations for commodities and printing in accordance with W. Va. Code § 5A-3-37(b). In effect, non-resident vendors receiving a preference in their home states, will see that same preference granted to West Virginia resident vendors bidding against them in West Virginia. Any request for reciprocal preference must include with the bid any information necessary to evaluate and confirm the applicability of the preference. A request form to help facilitate the request can be found at: www.state.wv.us/admin/purchase/vrc/Venpref.pdf.

16. SMALL, WOMEN-OWNED, OR MINORITY-OWNED BUSINESSES: For any solicitations publicly advertised for bid, in accordance with West Virginia Code §5A-3-37 and W. Va. CSR § 148-22-9, any non-resident vendor certified as a small, women-owned, or minority-owned business under W. Va. CSR § 148-22-9 shall be provided the same preference made available to any resident vendor. Any non-resident small, women-owned, or minority-owned business must identify itself as such in writing, must submit that writing to the Purchasing Division with its bid, and must be properly certified under W. Va. CSR § 148-22-9 prior to contract award to receive the preferences made available to resident vendors. Preference for a non-resident small, women-owned, or minority owned business shall be applied in accordance with W. Va. CSR § 148-22-9.

17. WAIVER OF MINOR IRREGULARITIES: The Director reserves the right to waive minor irregularities in bids or specifications in accordance with West Virginia Code of State Rules § 148-1-4.6.

18. ELECTRONIC FILE ACCESS RESTRICTIONS: Vendor must ensure that its submission in wvOASIS can be accessed and viewed by the Purchasing Division staff immediately upon bid opening. The Purchasing Division will consider any file that cannot be immediately accessed and viewed at the time of the bid opening (such as, encrypted files, password protected files, or incompatible files) to be blank or incomplete as context requires and are therefore unacceptable. A vendor will not be permitted to unencrypt files, remove password protections, or resubmit documents after bid opening to make a file viewable if those documents are required with the bid. A Vendor may be required to provide document passwords or remove access restrictions to allow the Purchasing Division to print or electronically save documents provided that those documents are viewable by the Purchasing Division prior to obtaining the password or removing the access restriction.

19. NON-RESPONSIBLE: The Purchasing Division Director reserves the right to reject the bid of any vendor as Non-Responsible in accordance with W. Va. Code of State Rules § 148-1-5.3, when the Director determines that the vendor submitting the bid does not have the capability to fully perform or lacks the integrity and reliability to assure good-faith performance.”

20. ACCEPTANCE/REJECTION: The State may accept or reject any bid in whole, or in part in accordance with W. Va. Code of State Rules § 148-1-4.5. and § 148-1-6.4.b.”

21. YOUR SUBMISSION IS A PUBLIC DOCUMENT: Vendor's entire response to the Solicitation and the resulting Contract are public documents. As public documents, they will be disclosed to the public following the bid/proposal opening or award of the contract, as required by the competitive bidding laws of West Virginia Code §§ 5A-3-1 et seq., 5-22-1 et seq., and 5G-1-1 et seq. and the Freedom of Information Act West Virginia Code §§ 29B-1-1 et seq.

DO NOT SUBMIT MATERIAL YOU CONSIDER TO BE CONFIDENTIAL, A TRADE SECRET, OR OTHERWISE NOT SUBJECT TO PUBLIC DISCLOSURE.

Submission of any bid, proposal, or other document to the Purchasing Division constitutes your explicit consent to the subsequent public disclosure of the bid, proposal, or document. The Purchasing Division will disclose any document labeled "confidential," "proprietary," "trade secret," "private," or labeled with any other claim against public disclosure of the documents, to include any "trade secrets" as defined by West Virginia Code § 47-22-1 et seq. All submissions are subject to public disclosure without notice.

22. WITH THE BID REQUIREMENTS: In instances where these specifications require documentation or other information with the bid, and a vendor fails to provide it with the bid, the Director of the Purchasing Division reserves the right to request those items after bid opening and prior to contract award pursuant to the authority to waive minor irregularities in bids or specifications under W. Va. CSR § 148-1-4.6. This authority does not apply to instances where state law mandates receipt with the bid.

23. EMAIL NOTIFICATION OF AWARD: The Purchasing Division will attempt to provide bidders with e-mail notification of contract award when a solicitation that the bidder participated in has been awarded. For notification purposes, bidders must provide the Purchasing Division with a valid email address in the bid response. Bidders may also monitor wvOASIS or the Purchasing Division's website to determine when a contract has been awarded.

24. ISRAEL BOYCOTT CERTIFICATION: Vendor's act of submitting a bid in response to this solicitation shall be deemed a certification from bidder to the State that bidder is not currently engaged in, and will not for the duration of the contract, engage in a boycott of Israel. This certification is required by W. Va. Code § 5A-3-63.

GENERAL TERMS AND CONDITIONS:

1. CONTRACTUAL AGREEMENT: Issuance of an Award Document signed by the Purchasing Division Director, or his designee, and approved as to form by the Attorney General's office constitutes acceptance by the State of this Contract made by and between the State of West Virginia and the Vendor. Vendor's signature on its bid, or on the Contract if the Contract is not the result of a bid solicitation, signifies Vendor's agreement to be bound by and accept the terms and conditions contained in this Contract.

2. DEFINITIONS: As used in this Solicitation/Contract, the following terms shall have the meanings attributed to them below. Additional definitions may be found in the specifications included with this Solicitation/Contract.

2.1. "Agency" or "Agencies" means the agency, board, commission, or other entity of the State of West Virginia that is identified on the first page of the Solicitation or any other public entity seeking to procure goods or services under this Contract.

2.2. "Bid" or "Proposal" means the vendors submitted response to this solicitation.

2.3. "Contract" means the binding agreement that is entered into between the State and the Vendor to provide the goods or services requested in the Solicitation.

2.4. "Director" means the Director of the West Virginia Department of Administration, Purchasing Division.

2.5. "Purchasing Division" means the West Virginia Department of Administration, Purchasing Division.

2.6. "Award Document" means the document signed by the Agency and the Purchasing Division, and approved as to form by the Attorney General, that identifies the Vendor as the contract holder.

2.7. "Solicitation" means the official notice of an opportunity to supply the State with goods or services that is published by the Purchasing Division.

2.8. "State" means the State of West Virginia and/or any of its agencies, commissions, boards, etc. as context requires.

2.9. "Vendor" or "Vendors" means any entity submitting a bid in response to the Solicitation, the entity that has been selected as the lowest responsible bidder, or the entity that has been awarded the Contract as context requires.

3. CONTRACT TERM; RENEWAL; EXTENSION: The term of this Contract shall be determined in accordance with the category that has been identified as applicable to this Contract below:

Term Contract

Initial Contract Term: The Initial Contract Term will be for a period of _____. The Initial Contract Term becomes effective on the effective start date listed on the first page of this Contract, identified as the State of West Virginia contract cover page containing the signatures of the Purchasing Division, Attorney General, and Encumbrance clerk (or another page identified as _____), and the Initial Contract Term ends on the effective end date also shown on the first page of this Contract.

Renewal Term: This Contract may be renewed upon the mutual written consent of the Agency, and the Vendor, with approval of the Purchasing Division and the Attorney General's office (Attorney General approval is as to form only). Any request for renewal should be delivered to the Agency and then submitted to the Purchasing Division thirty (30) days prior to the expiration date of the initial contract term or appropriate renewal term. A Contract renewal shall be in accordance with the terms and conditions of the original contract. Unless otherwise specified below, renewal of this Contract is limited to _____ successive one (1) year periods or multiple renewal periods of less than one year, provided that the multiple renewal periods do not exceed the total number of months available in all renewal years combined. Automatic renewal of this Contract is prohibited. Renewals must be approved by the Vendor, Agency, Purchasing Division and Attorney General's office (Attorney General approval is as to form only)

Alternate Renewal Term – This contract may be renewed for _____ successive _____ year periods or shorter periods provided that they do not exceed the total number of months contained in all available renewals. Automatic renewal of this Contract is prohibited. Renewals must be approved by the Vendor, Agency, Purchasing Division and Attorney General's office (Attorney General approval is as to form only)

Delivery Order Limitations: In the event that this contract permits delivery orders, a delivery order may only be issued during the time this Contract is in effect. Any delivery order issued within one year of the expiration of this Contract shall be effective for one year from the date the delivery order is issued. No delivery order may be extended beyond one year after this Contract has expired.

Fixed Period Contract: This Contract becomes effective upon Vendor's receipt of the notice to proceed and must be completed within _____ days.

Fixed Period Contract with Renewals: This Contract becomes effective upon Vendor's receipt of the notice to proceed and part of the Contract more fully described in the attached specifications must be completed within _____ days. Upon completion of the work covered by the preceding sentence, the vendor agrees that:

the contract will continue for _____ years;

the contract may be renewed for _____ successive _____ year periods or shorter periods provided that they do not exceed the total number of months contained in all available renewals. Automatic renewal of this Contract is prohibited. Renewals must be approved by the Vendor, Agency, Purchasing Division and Attorney General's Office (Attorney General approval is as to form only).

One-Time Purchase: The term of this Contract shall run from the issuance of the Award Document until all of the goods contracted for have been delivered, but in no event will this Contract extend for more than one fiscal year.

Construction/Project Oversight: This Contract becomes effective on the effective start date listed on the first page of this Contract, identified as the State of West Virginia contract cover page containing the signatures of the Purchasing Division, Attorney General, and Encumbrance clerk (or another page identified as _____), and continues until the project for which the vendor is providing oversight is complete.

Other: Contract Term specified in _____

4. AUTHORITY TO PROCEED: Vendor is authorized to begin performance of this contract on the date of encumbrance listed on the front page of the Award Document unless either the box for "Fixed Period Contract" or "Fixed Period Contract with Renewals" has been checked in Section 3 above. If either "Fixed Period Contract" or "Fixed Period Contract with Renewals" has been checked, Vendor must not begin work until it receives a separate notice to proceed from the State. The notice to proceed will then be incorporated into the Contract via change order to memorialize the official date that work commenced.

5. QUANTITIES: The quantities required under this Contract shall be determined in accordance with the category that has been identified as applicable to this Contract below.

Open End Contract: Quantities listed in this Solicitation/Award Document are approximations only, based on estimates supplied by the Agency. It is understood and agreed that the Contract shall cover the quantities actually ordered for delivery during the term of the Contract, whether more or less than the quantities shown.

Service: The scope of the service to be provided will be more clearly defined in the specifications included herewith.

Combined Service and Goods: The scope of the service and deliverable goods to be provided will be more clearly defined in the specifications included herewith.

One-Time Purchase: This Contract is for the purchase of a set quantity of goods that are identified in the specifications included herewith. Once those items have been delivered, no additional goods may be procured under this Contract without an appropriate change order approved by the Vendor, Agency, Purchasing Division, and Attorney General's office.

Construction: This Contract is for construction activity more fully defined in the specifications.

6. EMERGENCY PURCHASES: The Purchasing Division Director may authorize the Agency to purchase goods or services in the open market that Vendor would otherwise provide under this Contract if those goods or services are for immediate or expedited delivery in an emergency. Emergencies shall include, but are not limited to, delays in transportation or an unanticipated increase in the volume of work. An emergency purchase in the open market, approved by the Purchasing Division Director, shall not constitute a breach of this Contract and shall not entitle the Vendor to any form of compensation or damages. This provision does not excuse the State from fulfilling its obligations under a One-Time Purchase contract.

7. REQUIRED DOCUMENTS: All of the items checked in this section must be provided to the Purchasing Division by the Vendor as specified:

LICENSE(S) / CERTIFICATIONS / PERMITS: In addition to anything required under the Section of the General Terms and Conditions entitled Licensing, the apparent successful Vendor shall furnish proof of the following licenses, certifications, and/or permits upon request and in a form acceptable to the State. The request may be prior to or after contract award at the State's sole discretion.

The apparent successful Vendor shall also furnish proof of any additional licenses or certifications contained in the specifications regardless of whether or not that requirement is listed above.

8. INSURANCE: The apparent successful Vendor shall furnish proof of the insurance identified by a checkmark below prior to Contract award. The insurance coverages identified below must be maintained throughout the life of this contract. Thirty (30) days prior to the expiration of the insurance policies, Vendor shall provide the Agency with proof that the insurance mandated herein has been continued. Vendor must also provide Agency with immediate notice of any changes in its insurance policies, including but not limited to, policy cancelation, policy reduction, or change in insurers. The apparent successful Vendor shall also furnish proof of any additional insurance requirements contained in the specifications prior to Contract award regardless of whether that insurance requirement is listed in this section.

Vendor must maintain:

Commercial General Liability Insurance in at least an amount of: \$1,000,000.00 per occurrence.

Automobile Liability Insurance in at least an amount of: _____ per occurrence.

Professional/Malpractice/Errors and Omission Insurance in at least an amount of: _____ per occurrence. Notwithstanding the forgoing, Vendor's are not required to list the State as an additional insured for this type of policy.

Commercial Crime and Third Party Fidelity Insurance in an amount of: _____ per occurrence.

Cyber Liability Insurance in an amount of: _____ per occurrence.

Builders Risk Insurance in an amount equal to 100% of the amount of the Contract.

Pollution Insurance in an amount of: _____ per occurrence.

Aircraft Liability in an amount of: _____ per occurrence.

9. WORKERS' COMPENSATION INSURANCE: Vendor shall comply with laws relating to workers compensation, shall maintain workers' compensation insurance when required, and shall furnish proof of workers' compensation insurance upon request.

10. VENUE: All legal actions for damages brought by Vendor against the State shall be brought in the West Virginia Claims Commission. Other causes of action must be brought in the West Virginia court authorized by statute to exercise jurisdiction over it.

11. LIQUIDATED DAMAGES: This clause shall in no way be considered exclusive and shall not limit the State or Agency's right to pursue any other available remedy. Vendor shall pay liquidated damages in the amount specified below or as described in the specifications:

_____ for _____.

Liquidated Damages Contained in the Specifications.

Liquidated Damages Are Not Included in this Contract.

12. ACCEPTANCE: Vendor's signature on its bid, or on the certification and signature page, constitutes an offer to the State that cannot be unilaterally withdrawn, signifies that the product or service proposed by vendor meets the mandatory requirements contained in the Solicitation for that product or service, unless otherwise indicated, and signifies acceptance of the terms and conditions contained in the Solicitation unless otherwise indicated.

13. PRICING: The pricing set forth herein is firm for the life of the Contract, unless specified elsewhere within this Solicitation/Contract by the State. A Vendor's inclusion of price adjustment provisions in its bid, without an express authorization from the State in the Solicitation to do so, may result in bid disqualification. Notwithstanding the foregoing, Vendor must extend any publicly advertised sale price to the State and invoice at the lower of the contract price or the publicly advertised sale price.

14. PAYMENT IN ARREARS: Payments for goods/services will be made in arrears only upon receipt of a proper invoice, detailing the goods/services provided or receipt of the goods/services, whichever is later. Notwithstanding the foregoing, payments for software maintenance, licenses, or subscriptions may be paid annually in advance.

15. PAYMENT METHODS: Vendor must accept payment by electronic funds transfer and P-Card. (The State of West Virginia's Purchasing Card program, administered under contract by a banking institution, processes payment for goods and services through state designated credit cards.)

16. TAXES: The Vendor shall pay any applicable sales, use, personal property or any other taxes arising out of this Contract and the transactions contemplated thereby. The State of West Virginia is exempt from federal and state taxes and will not pay or reimburse such taxes.

17. ADDITIONAL FEES: Vendor is not permitted to charge additional fees or assess additional charges that were not either expressly provided for in the solicitation published by the State of West Virginia, included in the Contract, or included in the unit price or lump sum bid amount that Vendor is required by the solicitation to provide. Including such fees or charges as notes to the solicitation may result in rejection of vendor's bid. Requesting such fees or charges be paid after the contract has been awarded may result in cancellation of the contract.

18. FUNDING: This Contract shall continue for the term stated herein, contingent upon funds being appropriated by the Legislature or otherwise being made available. In the event funds are not appropriated or otherwise made available, this Contract becomes void and of no effect beginning on July 1 of the fiscal year for which funding has not been appropriated or otherwise made available. If that occurs, the State may notify the Vendor that an alternative source of funding has been obtained and thereby avoid the automatic termination. Non-appropriation or non-funding shall not be considered an event of default.

19. CANCELLATION: The Purchasing Division Director reserves the right to cancel this Contract immediately upon written notice to the vendor if the materials or workmanship supplied do not conform to the specifications contained in the Contract. The Purchasing Division Director may also cancel any purchase or Contract upon 30 days written notice to the Vendor in accordance with West Virginia Code of State Rules § 148-1-5.2.b.

20. TIME: Time is of the essence regarding all matters of time and performance in this Contract.

21. APPLICABLE LAW: This Contract is governed by and interpreted under West Virginia law without giving effect to its choice of law principles. Any information provided in specification manuals, or any other source, verbal or written, which contradicts or violates the West Virginia Constitution, West Virginia Code, or West Virginia Code of State Rules is void and of no effect.

22. COMPLIANCE WITH LAWS: Vendor shall comply with all applicable federal, state, and local laws, regulations and ordinances. By submitting a bid, Vendor acknowledges that it has reviewed, understands, and will comply with all applicable laws, regulations, and ordinances.

SUBCONTRACTOR COMPLIANCE: Vendor shall notify all subcontractors providing commodities or services related to this Contract that as subcontractors, they too are required to comply with all applicable laws, regulations, and ordinances. Notification under this provision must occur prior to the performance of any work under the contract by the subcontractor.

23. ARBITRATION: Any references made to arbitration contained in this Contract, Vendor's bid, or in any American Institute of Architects documents pertaining to this Contract are hereby deleted, void, and of no effect.

24. MODIFICATIONS: This writing is the parties' final expression of intent. Notwithstanding anything contained in this Contract to the contrary no modification of this Contract shall be binding without mutual written consent of the Agency, and the Vendor, with approval of the Purchasing Division and the Attorney General's office (Attorney General approval is as to form only). Any change to existing contracts that adds work or changes contract cost, and were not included in the original contract, must be approved by the Purchasing Division and the Attorney General's Office (as to form) prior to the implementation of the change or commencement of work affected by the change.

25. WAIVER: The failure of either party to insist upon a strict performance of any of the terms or provision of this Contract, or to exercise any option, right, or remedy herein contained, shall not be construed as a waiver or a relinquishment for the future of such term, provision, option, right, or remedy, but the same shall continue in full force and effect. Any waiver must be expressly stated in writing and signed by the waiving party.

26. SUBSEQUENT FORMS: The terms and conditions contained in this Contract shall supersede any and all subsequent terms and conditions which may appear on any form documents submitted by Vendor to the Agency or Purchasing Division such as price lists, order forms, invoices, sales agreements, or maintenance agreements, and includes internet websites or other electronic documents. Acceptance or use of Vendor's forms does not constitute acceptance of the terms and conditions contained thereon.

27. ASSIGNMENT: Neither this Contract nor any monies due, or to become due hereunder, may be assigned by the Vendor without the express written consent of the Agency, the Purchasing Division, the Attorney General's office (as to form only), and any other government agency or office that may be required to approve such assignments.

28. WARRANTY: The Vendor expressly warrants that the goods and/or services covered by this Contract will: (a) conform to the specifications, drawings, samples, or other description furnished or specified by the Agency; (b) be merchantable and fit for the purpose intended; and (c) be free from defect in material and workmanship.

29. STATE EMPLOYEES: State employees are not permitted to utilize this Contract for personal use and the Vendor is prohibited from permitting or facilitating the same.

30. PRIVACY, SECURITY, AND CONFIDENTIALITY: The Vendor agrees that it will not disclose to anyone, directly or indirectly, any such personally identifiable information or other confidential information gained from the Agency, unless the individual who is the subject of the information consents to the disclosure in writing or the disclosure is made pursuant to the Agency's policies, procedures, and rules. Vendor further agrees to comply with the Confidentiality Policies and Information Security Accountability Requirements, set forth in www.state.wv.us/admin/purchase/privacy.

31. YOUR SUBMISSION IS A PUBLIC DOCUMENT: Vendor's entire response to the Solicitation and the resulting Contract are public documents. As public documents, they will be disclosed to the public following the bid/proposal opening or award of the contract, as required by the competitive bidding laws of West Virginia Code §§ 5A-3-1 et seq., 5-22-1 et seq., and 5G-1-1 et seq. and the Freedom of Information Act West Virginia Code §§ 29B-1-1 et seq.

DO NOT SUBMIT MATERIAL YOU CONSIDER TO BE CONFIDENTIAL, A TRADE SECRET, OR OTHERWISE NOT SUBJECT TO PUBLIC DISCLOSURE.

Submission of any bid, proposal, or other document to the Purchasing Division constitutes your explicit consent to the subsequent public disclosure of the bid, proposal, or document. The Purchasing Division will disclose any document labeled "confidential," "proprietary," "trade secret," "private," or labeled with any other claim against public disclosure of the documents, to include any "trade secrets" as defined by West Virginia Code § 47-22-1 et seq. All submissions are subject to public disclosure without notice.

32. LICENSING: In accordance with West Virginia Code of State Rules § 148-1-6.1.e, Vendor must be licensed and in good standing in accordance with any and all state and local laws and requirements by any state or local agency of West Virginia, including, but not limited to, the West Virginia Secretary of State's Office, the West Virginia Tax Department, West Virginia Insurance Commission, or any other state agency or political subdivision. Obligations related to political subdivisions may include, but are not limited to, business licensing, business and occupation taxes, inspection compliance, permitting, etc. Upon request, the Vendor must provide all necessary releases to obtain information to enable the Purchasing Division Director or the Agency to verify that the Vendor is licensed and in good standing with the above entities.

SUBCONTRACTOR COMPLIANCE: Vendor shall notify all subcontractors providing commodities or services related to this Contract that as subcontractors, they too are required to be licensed, in good standing, and up-to-date on all state and local obligations as described in this section. Obligations related to political subdivisions may include, but are not limited to, business licensing, business and occupation taxes, inspection compliance, permitting, etc. Notification under this provision must occur prior to the performance of any work under the contract by the subcontractor.

33. ANTITRUST: In submitting a bid to, signing a contract with, or accepting a Award Document from any agency of the State of West Virginia, the Vendor agrees to convey, sell, assign, or transfer to the State of West Virginia all rights, title, and interest in and to all causes of action it may now or hereafter acquire under the antitrust laws of the United States and the State of West Virginia for price fixing and/or unreasonable restraints of trade relating to the particular commodities or services purchased or acquired by the State of West Virginia. Such assignment shall be made and become effective at the time the purchasing agency tenders the initial payment to Vendor.

34. VENDOR NON-CONFLICT: Neither Vendor nor its representatives are permitted to have any interest, nor shall they acquire any interest, direct or indirect, which would compromise the performance of its services hereunder. Any such interests shall be promptly presented in detail to the Agency.

35. VENDOR RELATIONSHIP: The relationship of the Vendor to the State shall be that of an independent contractor and no principal-agent relationship or employer-employee relationship is contemplated or created by this Contract. The Vendor as an independent contractor is solely liable for the acts and omissions of its employees and agents. Vendor shall be responsible for selecting, supervising, and compensating any and all individuals employed pursuant to the terms of this Solicitation and resulting contract. Neither the Vendor, nor any employees or subcontractors of the Vendor, shall be deemed to be employees of the State for any purpose whatsoever. Vendor shall be exclusively responsible for payment of employees and contractors for all wages and salaries, taxes, withholding payments, penalties, fees, fringe benefits, professional liability insurance premiums, contributions to insurance and pension, or other deferred compensation plans, including but not limited to, Workers' Compensation and Social Security obligations, licensing fees, etc. and the filing of all necessary documents, forms, and returns pertinent to all of the foregoing.

Vendor shall hold harmless the State, and shall provide the State and Agency with a defense against any and all claims including, but not limited to, the foregoing payments, withholdings, contributions, taxes, Social Security taxes, and employer income tax returns.

36. INDEMNIFICATION: The Vendor agrees to indemnify, defend, and hold harmless the State and the Agency, their officers, and employees from and against: (1) Any claims or losses for services rendered by any subcontractor, person, or firm performing or supplying services, materials, or supplies in connection with the performance of the Contract; (2) Any claims or losses resulting to any person or entity injured or damaged by the Vendor, its officers, employees, or subcontractors by the publication, translation, reproduction, delivery, performance, use, or disposition of any data used under the Contract in a manner not authorized by the Contract, or by Federal or State statutes or regulations; and (3) Any failure of the Vendor, its officers, employees, or subcontractors to observe State and Federal laws including, but not limited to, labor and wage and hour laws.

37. NO DEBT CERTIFICATION: In accordance with West Virginia Code §§ 5A-3-10a and 5-22-1(i), the State is prohibited from awarding a contract to any bidder that owes a debt to the State or a political subdivision of the State. By submitting a bid, or entering into a contract with the State, Vendor is affirming that (1) for construction contracts, the Vendor is not in default on any monetary obligation owed to the state or a political subdivision of the state, and (2) for all other contracts, neither the Vendor nor any related party owe a debt as defined above, and neither the Vendor nor any related party are in employer default as defined in the statute cited above unless the debt or employer default is permitted under the statute.

38. CONFLICT OF INTEREST: Vendor, its officers or members or employees, shall not presently have or acquire an interest, direct or indirect, which would conflict with or compromise the performance of its obligations hereunder. Vendor shall periodically inquire of its officers, members and employees to ensure that a conflict of interest does not arise. Any conflict of interest discovered shall be promptly presented in detail to the Agency.

39. REPORTS: Vendor shall provide the Agency and/or the Purchasing Division with the following reports identified by a checked box below:

Such reports as the Agency and/or the Purchasing Division may request. Requested reports may include, but are not limited to, quantities purchased, agencies utilizing the contract, total contract expenditures by agency, etc.

Quarterly reports detailing the total quantity of purchases in units and dollars, along with a listing of purchases by agency. Quarterly reports should be delivered to the Purchasing Division via email at purchasing.division@wv.gov.

40. BACKGROUND CHECK: In accordance with W. Va. Code § 15-2D-3, the State reserves the right to prohibit a service provider's employees from accessing sensitive or critical information or to be present at the Capitol complex based upon results addressed from a criminal background check. Service providers should contact the West Virginia Division of Protective Services by phone at (304) 558-9911 for more information.

41. PREFERENCE FOR USE OF DOMESTIC STEEL PRODUCTS: Except when authorized by the Director of the Purchasing Division pursuant to W. Va. Code § 5A-3-56, no contractor may use or supply steel products for a State Contract Project other than those steel products made in the United States. A contractor who uses steel products in violation of this section may be subject to civil penalties pursuant to W. Va. Code § 5A-3-56. As used in this section:

- a. "State Contract Project" means any erection or construction of, or any addition to, alteration of or other improvement to any building or structure, including, but not limited to, roads or highways, or the installation of any heating or cooling or ventilating plants or other equipment, or the supply of and materials for such projects, pursuant to a contract with the State of West Virginia for which bids were solicited on or after June 6, 2001.
- b. "Steel Products" means products rolled, formed, shaped, drawn, extruded, forged, cast, fabricated or otherwise similarly processed, or processed by a combination of two or more or such operations, from steel made by the open hearth, basic oxygen, electric furnace, Bessemer or other steel making process.
- c. The Purchasing Division Director may, in writing, authorize the use of foreign steel products if:
 1. The cost for each contract item used does not exceed one tenth of one percent (.1%) of the total contract cost or two thousand five hundred dollars (\$2,500.00), whichever is greater. For the purposes of this section, the cost is the value of the steel product as delivered to the project; or
 2. The Director of the Purchasing Division determines that specified steel materials are not produced in the United States in sufficient quantity or otherwise are not reasonably available to meet contract requirements.

42. PREFERENCE FOR USE OF DOMESTIC ALUMINUM, GLASS, AND STEEL: In Accordance with W. Va. Code § 5-19-1 et seq., and W. Va. CSR § 148-10-1 et seq., for every contract or subcontract, subject to the limitations contained herein, for the construction, reconstruction, alteration, repair, improvement or maintenance of public works or for the purchase of any item of machinery or equipment to be used at sites of public works, only domestic aluminum, glass or steel products shall be supplied unless the spending officer determines, in writing, after the receipt of offers or bids, (1) that the cost of domestic aluminum, glass or steel products is unreasonable or inconsistent with the public interest of the State of West Virginia, (2) that domestic aluminum, glass or steel products are not produced in sufficient quantities to meet the contract requirements, or (3) the available domestic aluminum, glass, or steel do not meet the contract specifications. This provision only applies to public works contracts awarded in an amount more than fifty thousand dollars (\$50,000) or public works contracts that require more than ten thousand pounds of steel products.

The cost of domestic aluminum, glass, or steel products may be unreasonable if the cost is more than twenty percent (20%) of the bid or offered price for foreign made aluminum, glass, or steel products. If the domestic aluminum, glass or steel products to be supplied or produced in a “substantial labor surplus area”, as defined by the United States Department of Labor, the cost of domestic aluminum, glass, or steel products may be unreasonable if the cost is more than thirty percent (30%) of the bid or offered price for foreign made aluminum, glass, or steel products. This preference shall be applied to an item of machinery or equipment, as indicated above, when the item is a single unit of equipment or machinery manufactured primarily of aluminum, glass or steel, is part of a public works contract and has the sole purpose or of being a permanent part of a single public works project. This provision does not apply to equipment or machinery purchased by a spending unit for use by that spending unit and not as part of a single public works project.

All bids and offers including domestic aluminum, glass or steel products that exceed bid or offer prices including foreign aluminum, glass or steel products after application of the preferences provided in this provision may be reduced to a price equal to or lower than the lowest bid or offer price for foreign aluminum, glass or steel products plus the applicable preference. If the reduced bid or offer prices are made in writing and supersede the prior bid or offer prices, all bids or offers, including the reduced bid or offer prices, will be reevaluated in accordance with this rule.

43. INTERESTED PARTY SUPPLEMENTAL DISCLOSURE: W. Va. Code § 6D-1-2 requires that for contracts with an actual or estimated value of at least \$1 million, the Vendor must submit to the Agency a disclosure of interested parties prior to beginning work under this Contract. Additionally, the Vendor must submit a supplemental disclosure of interested parties reflecting any new or differing interested parties to the contract, which were not included in the original pre-work interested party disclosure, within 30 days following the completion or termination of the contract. A copy of that form is included with this solicitation or can be obtained from the WV Ethics Commission. This requirement does not apply to publicly traded companies listed on a national or international stock exchange. A more detailed definition of interested parties can be obtained from the form referenced above.

44. PROHIBITION AGAINST USED OR REFURBISHED: Unless expressly permitted in the solicitation published by the State, Vendor must provide new, unused commodities, and is prohibited from supplying used or refurbished commodities, in fulfilling its responsibilities under this Contract.

45. VOID CONTRACT CLAUSES: This Contract is subject to the provisions of West Virginia Code § 5A-3-62, which automatically voids certain contract clauses that violate State law.

46. ISRAEL BOYCOTT: Bidder understands and agrees that, pursuant to W. Va. Code § 5A-3-63, it is prohibited from engaging in a boycott of Israel during the term of this contract.

DESIGNATED CONTACT: Vendor appoints the individual identified in this Section as the Contract Administrator and the initial point of contact for matters relating to this Contract.

(Printed Name and Title) Trent May / Sales Rep

(Address) 19 Goff Crossing Drive Cross Lanes, WV 25313

(Phone Number) / (Fax Number) 304-204-1818 / 304-204-1811

(email address) maytrent@lec1.com

CERTIFICATION AND SIGNATURE: By signing below, or submitting documentation through wvOASIS, I certify that: I have reviewed this Solicitation/Contract in its entirety; that I understand the requirements, terms and conditions, and other information contained herein; that this bid, offer or proposal constitutes an offer to the State that cannot be unilaterally withdrawn; that the product or service proposed meets the mandatory requirements contained in the Solicitation/Contract for that product or service, unless otherwise stated herein; that the Vendor accepts the terms and conditions contained in the Solicitation, unless otherwise stated herein; that I am submitting this bid, offer or proposal for review and consideration; that this bid or offer was made without prior understanding, agreement, or connection with any entity submitting a bid or offer for the same material, supplies, equipment or services; that this bid or offer is in all respects fair and without collusion or fraud; that this Contract is accepted or entered into without any prior understanding, agreement, or connection to any other entity that could be considered a violation of law; that I am authorized by the Vendor to execute and submit this bid, offer, or proposal, or any documents related thereto on Vendor's behalf; that I am authorized to bind the vendor in a contractual relationship; and that to the best of my knowledge, the vendor has properly registered with any State agency that may require registration.

By signing below, I further certify that I understand this Contract is subject to the provisions of West Virginia Code § 5A-3-62, which automatically voids certain contract clauses that violate State law; and that pursuant to W. Va. Code 5A-3-63, the entity entering into this contract is prohibited from engaging in a boycott against Israel.

Leslie Equipment Company

(Company)

(Signature of Authorized Representative)

(Printed Name and Title of Authorized Representative) (Date)

Trent May / Sales Rep

(Phone Number) (Fax Number)

304-204-1818 / 304-204-1811

(Email Address)

REQUEST FOR QUOTATION
(1) Compact Excavator – Camp Dawson Environmental Section

SPECIFICATIONS

- 1. PURPOSE AND SCOPE:** The West Virginia Purchasing Division is soliciting bids on behalf of West Virginia Army National Guard's, Environmental Protection Division at Camp Dawson in Kingwood, WV, to establish a contract for the one-time purchase of one (1) compact excavator.

NOTICE TO OFFEROR(S)/SUPPLIER(S): FUNDS ARE NOT PRESENTLY AVAILABLE FOR THIS EFFORT. NO AWARD WILL BE MADE UNDER THIS SOLICITATION UNTIL FUNDS ARE AVAILABLE. THE GOVERNMENT RESERVES THE RIGHT TO CANCEL THIS SOLICITATION, EITHER BEFORE OR AFTER THE CLOSING DATE. IN THE EVENT THE GOVERNMENT CANCELS THIS SOLICITATION, THE GOVERNMENT HAS NO OBLIGATION TO REIMBURSE AN OFFEROR FOR ANY COSTS.

- 2. DEFINITIONS:** The terms listed below shall have the meanings assigned to them below. Additional definitions can be found in Section 2 of the General Terms and Conditions.

2.1 “Contract Item” means a compact excavator with extendable arm, accessories, and attachments.

2.2 “Bid Evaluation Page” means the page upon which Vendor should list its proposed price for the Desired Items in the manner requested by thereon. The Desired Item is either included on the last page of this RFQ or attached hereto as Exhibit A.

2.3 “RFQ” means the official solicitation published by the Purchasing Division.

3. GENERAL REQUIREMENTS:

- 3.1 Mandatory Desired Item Requirements:** Desired Item must meet or exceed the mandatory requirements listed below.

3.1.1 Contract Item # 1: E60 R2-Series Bobcat Compact Excavator, or Equal (QTY 1)

3.1.1.1 Vendor must provide a quantity of one (1) new Model E60 R2-Series Bobcat Compact Excavator, or equal. Excavator must be equipped and/or fitted with current standard manufacturer's equipment and features. If bidding an alternate compact excavator, Vendor must clearly identify alternate excavator and provide manufacturer's specifications, manufacturer's literature and/or any other relevant verifiable

REQUEST FOR QUOTATION
(1) Compact Excavator – Camp Dawson Environmental Section

documentation that demonstrates the alternate excavator meets the desired mandatory specifications.

The unit is also to be equipped and/or fitted with:

- 3.1.1.2 Functional option packages P83 and C52 below, or Equal.
- 3.1.1.3 Bucket, Grading, 36”, MX4 X-Change, No teeth, or Equal
- 3.1.1.4 Bucket, Teeth, 24”, MX4 X-Change, or Equal
- 3.1.1.5 Trencher, With Chain, 2’, Double Standard, CC/4-Inch, MX112, or Equal
- 3.1.1.6 Extendable Arm
- 3.1.1.7 Power Tilt, PTX4, or Equal
- 3.1.1.8 Rubber Tracks
- 3.1.1.9 Excavator Hose Kit
- 3.1.1.10 Flail Mower, 40”
- 3.1.1.11 Angle Blade
- 3.1.1.12 Hydraulic Clamp
- 3.1.1.13 Second Auxiliary Hydraulic System
- 3.1.1.14 Hydraulic X-Change System
- 3.1.1.15 Engine Block Heater
- 3.1.1.16 Enclosed Cab with HVAC
- 3.1.1.17 Deluxe Instrument Panel with Keyless Start
- 3.1.1.18 Deluxe Cloth Suspension Seat
- 3.1.1.19 Travel Motion Alarm
- 3.1.1.20 AM-FM Radio with Bluetooth and Touch Display
- 3.1.1.21 Falling Object Protective Structure must be in accordance with ISO 10262 (FOPS Level 1)
- 3.1.1.22 2000 Tip Over Protective Structure must be in accordance with ISO 12117 (TOPS Level 1)
- 3.1.1.23 2008 Roll Over Protective Structure must be in accordance with ISO 12117-2 (ROPS Level 1)
- 3.1.1.24 Vendor shall include a warranty of two (2) years, or two thousand (2000) hours.

4. CONTRACT AWARD

4.1 Contract Award: The Contract is intended to provide the agency with a purchase price for the Desired Items. The Contract shall be awarded to the Vendor that provides the Desired Items meeting the required specifications for the lowest overall total cost as shown on the Pricing Pages.

REQUEST FOR QUOTATION
(1) Compact Excavator – Camp Dawson Environmental Section

4.2 Pricing Page: Vendor should complete the Pricing Page by entering the unit price for each of the desired items and extending the unit price by the quantity noted to obtain the line-item price. The total of the line items should be noted at the bottom of the bid schedule for the total bid price. Unit prices to be inclusive of all freight/delivery costs. Vendor should complete the Pricing Page in full as failure to complete the Pricing Page in its entirety may result in Vendor's bid being disqualified.

Notwithstanding the foregoing, the Purchasing Division may correct errors as it deems appropriate. Vendor should enter the information into the Bid Evaluation Page to prevent errors in the evaluation.

5. PAYMENT:

5.1 Payment: Vendor shall accept payment in accordance with the payment procedures of the State of West Virginia. Methods of acceptable payment must include the West Virginia Purchasing Card. Payment in advance is not permitted under this Contract.

**WV Army National Guard
Attn: Accounts Payable
1707 Coonskin Drive
Charleston, WV 25311**

6. DELIVERY AND RETURN:

6.1 Shipment and Delivery: Vendor shall ship the Desired Items immediately after being awarded this Contract and receiving a purchase order.

6.2 Late Delivery: The Agency placing the order under this Contract must be notified in writing if the shipment of the Desired Items will be delayed for any reason. Any delay in delivery that could cause harm to an Agency will be grounds for cancellation of the Contract, and/or obtaining the Desired Items from a third party.

Any Agency seeking to obtain the Desired Items from a third party under this provision must first obtain approval of the Purchasing Division.

6.3 Delivery Payment/Risk of Loss: Vendor shall deliver the Desired Items F.O.B. destination to the Agency's location.

6.4 Return of Unacceptable Items: If the Agency deems the Desired Items to be unacceptable, the Desired Items shall be returned to Vendor at Vendor's expense and with no restocking charge. Vendor shall either make arrangements for the return within five (5) days of being notified that items are unacceptable, or permit the Agency to arrange for the return and reimburse Agency for delivery expenses. If the original packaging cannot be utilized for the return, Vendor will supply the Agency

REQUEST FOR QUOTATION
(1) Compact Excavator – Camp Dawson Environmental Section

with appropriate return packaging upon request. All returns of unacceptable items shall be F.O.B. the Agency's location. The returned product shall either be replaced, or the Agency shall receive a full credit or refund for the purchase price, at the Agency's discretion.

- 6.5 Return Due to Agency Error:** Items ordered in error by the Agency will be returned for credit within 30 days of receipt, F.O.B. Vendor's location. Vendor shall not charge a restocking fee if returned products are in a resalable condition. Items shall be deemed to be in a resalable condition if they are unused and in the original packaging. Any restocking fee for items not in a resalable condition shall be the lower of the Vendor's customary restocking fee or 5% of the total invoiced value of the returned items.



Department of Administration
 Purchasing Division
 2019 Washington Street East
 Post Office Box 50130
 Charleston, WV 25305-0130

State of West Virginia
 Centralized Request for Quote

Proc Folder: 1486050			Reason for Modification: Addendum No. 1
Doc Description: One (1) Compact Excavator w/ Accessories and Attachments			
Proc Type: Central Purchase Order			
Date Issued	Solicitation Closes	Solicitation No	Version
2024-08-19	2024-08-26 13:30	CRFQ 0603 ADJ2500000014	2

BID RECEIVING LOCATION

BID CLERK
 DEPARTMENT OF ADMINISTRATION
 PURCHASING DIVISION
 2019 WASHINGTON ST E
 CHARLESTON WV 25305
 US

VENDOR

Vendor Customer Code:

Vendor Name : Leslie Equipment Company

Address : 19 Goff Crossing Drive

Street :

City : Cross Lanes

State : WV **Country :** US **Zip :** 25313

Principal Contact : Trent Max

Vendor Contact Phone: 304-204-1818 **Extension:**

FOR INFORMATION CONTACT THE BUYER
 David H Pauline
 304-558-0067
 david.h.pauline@wv.gov

Vendor Signature X  **FEIN#** 55-049-3180 **DATE** 8-26-24

All offers subject to all terms and conditions contained in this solicitation

ADDITIONAL INFORMATION

Addendum No. 1
To provide responses to the Vendor Technical Questions, see attached.
Bid opening date and time remain August 26, 2024, at 1:30 pm., est.
No other changes.

INVOICE TO | **SHIP TO**

ADJUTANT GENERALS OFFICE
1703 COONSKIN DR
CHARLESTON WV
US

CAMP DAWSON ARMY TRAINING SITE
240 ARMY RD
KINGWOOD WV
US

Line	Comm Ln Desc	Qty	Unit Issue	Unit Price	Total Price
1	One (1) Compact Excavator	1.00000	LS		

Comm Code	Manufacturer	Specification	Model #
22101526			

Extended Description:
Contract Item 3.1.1. - Quantity of One (1) E60 R2-Series Bobcat Compact Excavator, or EQUAL, with accessories and attachments.

SCHEDULE OF EVENTS

Line	Event	Event Date
1	Vendor Technical Questions Due By 11:00 am., est.	2024-08-15

SOLICITATION NUMBER: CRFQ ADJ2500000014
Addendum Number: 1

The purpose of this addendum is to modify the solicitation identified as (“ADJ2500000014”) to reflect the change(s) identified and described below.

Applicable Addendum Category:

- Modify bid opening date and time.
- Modify specifications of product or service being sought.
- Attachment of vendor questions and responses.
- Attachment of pre-bid sign-in sheet.
- Correction of error.
- Other.

Description of Modification to Solicitation:

1. To provide response to the Vendor Technical Questions, see attached.
2. Bid opening date and time remains August 26, 2024, at 1:30pm., est.
3. No other changes.

Additional Documentation: Documentation related to this Addendum (if any) has been included herewith as Attachment A and is specifically incorporated herein by reference.

Terms and Conditions:

1. All provisions of the Solicitation and other addenda not modified herein shall remain in full force and effect.
2. Vendor should acknowledge receipt of all addenda issued for this Solicitation by completing an Addendum Acknowledgment, a copy of which is included herewith. Failure to acknowledge addenda may result in bid disqualification. The addendum acknowledgement should be submitted with the bid to expedite document processing.



DEPARTMENT OF THE ARMY
JOINT FORCES HEADQUARTERS WEST VIRGINIA
1707 COONSKIN DRIVE
CHARLESTON, WEST VIRGINIA 25311-1026

August 15, 2024

ADDENDUM NO. 2- CRFQ-ADJ2500000014

RE: One (1) Compact Excavator w/ Accessories and Attachments

TO: Prospective Bidders

FROM: West Virginia Adjutant General's Office

PART 1 – TO PROVIDE RESPONSES TO TECHNICAL QUESTIONS

Q1: What do the two option packages include? (3.1.1.2 functional option packages P83 and C5, below or equal.)

A1: The P83 extendable arm package (or equal) includes: Extendable arm (maximum reach at ground level 265.2 in., or greater). Angel blade, hydraulic clamp (thumb), second auxiliary hydraulic system, and hydraulic x-change system.

The C52 cab comfort package (or equal) includes: Enclosed cab with HVAC, deluxe instrument panel with keyless start, deluxe cloth suspension seat, travel motion alarm, and AM/FM radio with Bluetooth™ and touch display.

Q2: Would you accept machine with non-extendable arm? OR a smaller machine with extendable arm?

A2: Yes, the extendable arm is mandatory specification. Minimum reach at ground level should be 265.2 in., or greater.

Q3: 3.1.1.2 Could you please define the features in these packages that are required. I can not find information on what these packages include.

A3: The P83 extendable arm package (or equal) includes: Extendable arm (maximum reach at ground level 265.2 in., or greater). Angel blade, hydraulic clamp (thumb), second auxiliary hydraulic system, and hydraulic x-change system.

The C52 cab comfort package (or equal) includes: Enclosed cab with HVAC, deluxe instrument panel with keyless start, deluxe cloth suspension seat, travel motion alarm, and AM/FM radio with Bluetooth™ and touch display.

Q4: 3.1.1.14 Must mower be flail type? Would you allow a rotary cutter in place?

A4: Yes, the attachment we are looking for is the flail type. No, a rotary cutter would not be accepted.

Q5: The required specifications list the machine must have an extendable arm. Below is a chart listed for the machine that we can quote (Develon DX63-7). It would not have an extendable arm, but we can quote with our long arm. Can you please verify that the reach would be sufficient?

A5: The mandatory extendable arm must have a minimum reach at ground level should be 265.2 in., or greater.

Q6: The required specifications list the machine must have an angle blade. Develon currently only offers a straight blade. Is this something that would be absolutely needed?

A6: Yes, the attachment we are looking for is an angle blade due to the nature of the work that the excavator is intended for.

ADDENDUM ACKNOWLEDGEMENT FORM
SOLICITATION NO.: CRFQ ADJ2500000014

Instructions: Please acknowledge receipt of all addenda issued with this solicitation by completing this addendum acknowledgment form. Check the box next to each addendum received and sign below. Failure to acknowledge addenda may result in bid disqualification.

Acknowledgment: I hereby acknowledge receipt of the following addenda and have made the necessary revisions to my proposal, plans and/or specification, etc.

Addendum Numbers Received:

(Check the box next to each addendum received)

- | | | | |
|-------------------------------------|----------------|--------------------------|-----------------|
| <input checked="" type="checkbox"/> | Addendum No. 1 | <input type="checkbox"/> | Addendum No. 6 |
| <input checked="" type="checkbox"/> | Addendum No. 2 | <input type="checkbox"/> | Addendum No. 7 |
| <input type="checkbox"/> | Addendum No. 3 | <input type="checkbox"/> | Addendum No. 8 |
| <input type="checkbox"/> | Addendum No. 4 | <input type="checkbox"/> | Addendum No. 9 |
| <input type="checkbox"/> | Addendum No. 5 | <input type="checkbox"/> | Addendum No. 10 |

I understand that failure to confirm the receipt of addenda may be cause for rejection of this bid. I further understand that that any verbal representation made or assumed to be made during any oral discussion held between Vendor's representatives and any state personnel is not binding. Only the information issued in writing and added to the specifications by an official addendum is binding.

Leslie Equipment
Company

JR us
Authorized Signature

8-26-24
Date

NOTE: This addendum acknowledgement should be submitted with the bid to expedite document processing.



Department of Administration
 Purchasing Division
 2019 Washington Street East
 Post Office Box 50130
 Charleston, WV 25305-0130

State of West Virginia
 Centralized Request for Quote

Proc Folder: 1486050			Reason for Modification:
Doc Description: One (1) Compact Excavator w/ Accessories and Attachments			
Proc Type: Central Purchase Order			
Date Issued	Solicitation Closes	Solicitation No	Version
2024-08-12	2024-08-26 13:30	CRFQ 0603 ADJ2500000014	1

BID RECEIVING LOCATION

BID CLERK
 DEPARTMENT OF ADMINISTRATION
 PURCHASING DIVISION
 2019 WASHINGTON ST E
 CHARLESTON WV 25305
 US

VENDOR

Vendor Customer Code:

Vendor Name: Leslie Equipment Company

Address: 19 Goff Crossing Drive

Street:

City: Cross Lanes

State: WV **Country:** US **Zip:** 25313

Principal Contact: Trent May

Vendor Contact Phone: 304-204-1818 **Extension:**

FOR INFORMATION CONTACT THE BUYER

David H Pauline
 304-558-0067
 david.h.pauline@wv.gov

Vendor Signature X  **FEIN#** 55-049-3180 **DATE** 8-26-2024

All offers subject to all terms and conditions contained in this solicitation

ADDITIONAL INFORMATION

The West Virginia Purchasing Division is soliciting bids on behalf of West Virginia Army National Guard's, Environmental Protection Division at Camp Dawson in Kingwood, WV, to establish a contract for the one-time purchase of one (1) compact excavator with attachments and accessories.

INVOICE TO		SHIP TO	
ADJUTANT GENERALS OFFICE 1703 COONSKIN DR		CAMP DAWSON ARMY TRAINING SITE 240 ARMY RD	
CHARLESTON US	WV	KINGWOOD US	WV

Line	Comm Ln Desc	Qty	Unit Issue	Unit Price	Total Price
1	One (1) Compact Excavator	1.00000	LS		

Comm Code	Manufacturer	Specification	Model #
22101526	<i>John Deere</i>		<i>60P</i>

Extended Description:

Contract Item 3.1.1. - Quantity of One (1) E60 R2-Series Bobcat Compact Excavator, or EQUAL, with accessories and attachments.

SCHEDULE OF EVENTS

<u>Line</u>	<u>Event</u>	<u>Event Date</u>
1	Vendor Technical Questions Due By 11:00 am., est.	2024-08-15

	Document Phase	Document Description	Page
ADJ250000014	Final	One (1) Compact Excavator w/ Accessories and Attachments	3

ADDITIONAL TERMS AND CONDITIONS

See attached document(s) for additional Terms and Conditions

POWERTILT®

Next Generation





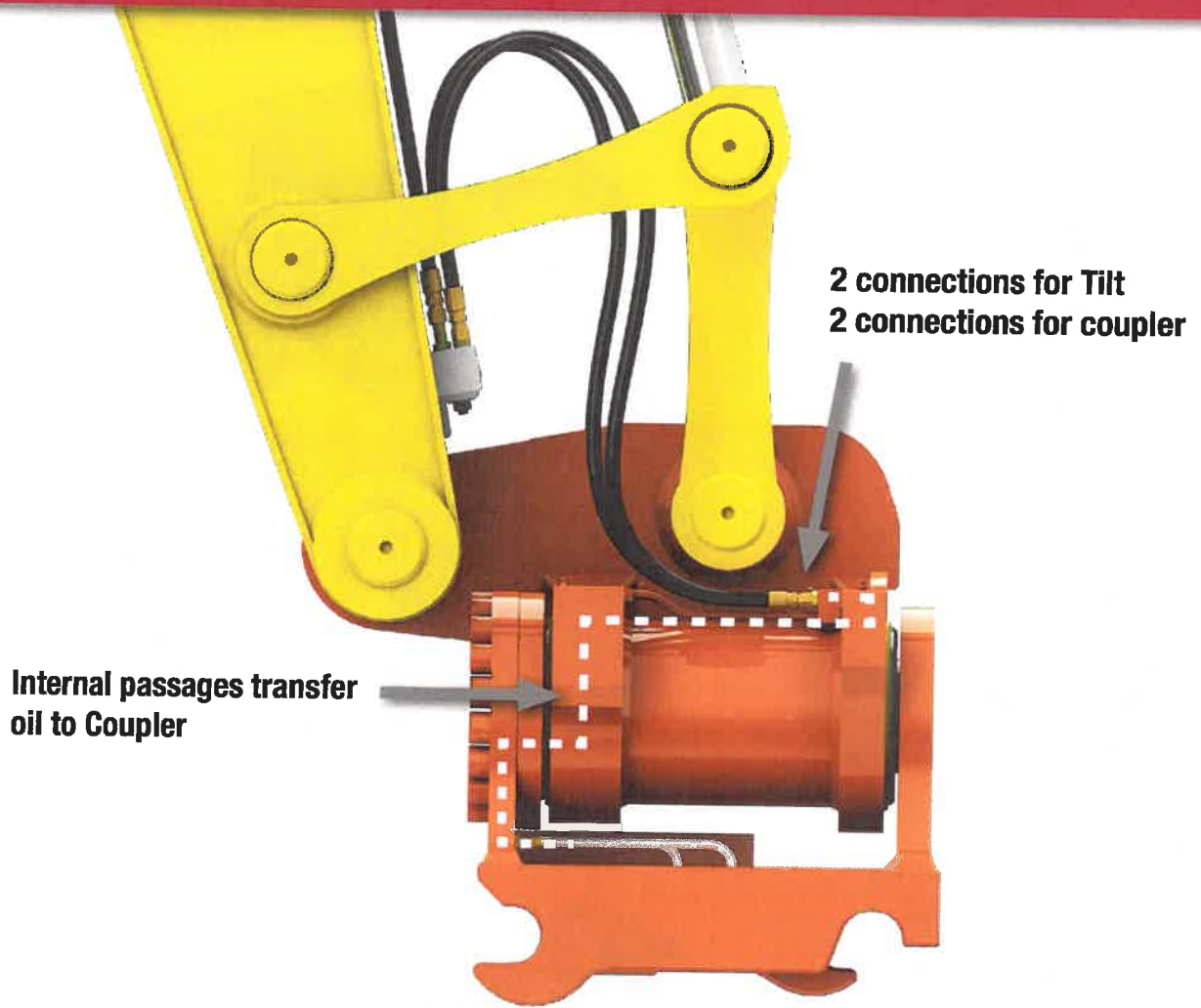

Tilt Any Bucket
or Attachment
up to 180 Degrees

HELAC®

Parker



POWERTILT CONFIGURATIONS

PT Series	PTS Series	PTA/PTS Blank Series	Custom Designs
	 	 	 

© 2017 Parker - Helac. All Rights Reserved. Patents — USA: 5,447,095; EP: 0 697 526; Europe: 2327840

60 P

Compact Excavator



JOHN DEERE





SMALLER MACHINE, BIGGER POTENTIAL

When you need more from your compact excavator, the John Deere 60 P-Tier might be your “one and done.” This small-but-mighty muscle specializes in making work in close quarters seem like no big deal. Loaded with customer-inspired ideas like significant lift and reach, precise control, and an amazingly comfortable cab, digging, excavating, and loading tasks become big possibilities. Plus it runs quiet, too. Jobsite-proven standard and optional advantages including your choice of tracks and John Deere attachments push the 60 P-Tier to make a sizable impact on the potential — and profitability — of your operation.

60 P-TIER COMPACT EXCAVATOR

FEATURES



**OPT FOR CANOPY
TO SUIT CLIMATE &
WORK CONDITIONS**

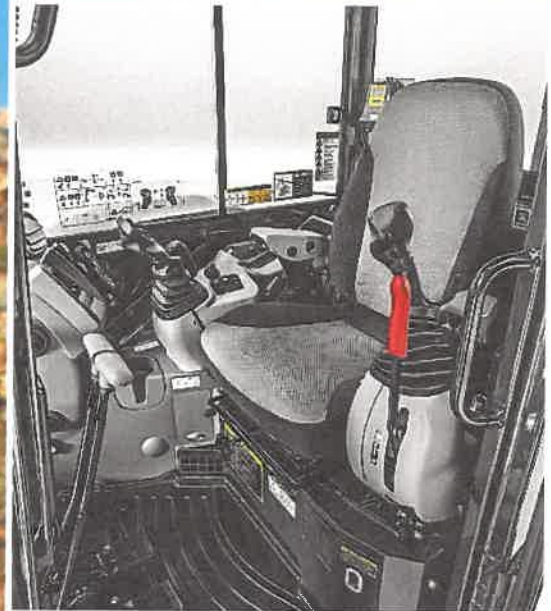

Comfort, quiet, and control

Spacious operator station has a wide entryway and backhoe- to excavator-style controls. Swing boom and foldable travel pedals are positioned for efficient operation and comfortable foot room. Noise-reducing aftertreatment device and isochronous high-idle speed help keep things noticeably quiet. Rubber cab mounts isolate the operator from noise and vibration.

Work, run, repeat

Reduced-tail-swing design maximizes maneuverability and performance in cramped places and tight spaces. Compact stature permits easy transport between jobsites, perfect for "dig-and-go" projects.

Resource management

Auto-idle automatically reduces engine speed when hydraulics aren't in use. Auto shutdown conserves precious fuel. Power/economy modes optimize power for digging applications, further improving fuel efficiency.

Get back to it

Standard backfill blade enables the 60 P-Tier to grade and fill, boosting machine versatility and stability when using attachments or working on uneven terrain.

Swing for the fences

Put the 60 P-Tier's independent-swing boom and 360-degree rotation to work taming difficult tasks. Impressive lift height and reach ease truck loading.

Handy hydraulics

Standard quick-coupler-equipped, boom-mounted auxiliary hydraulic lines simplify attachment hookup. Return-flow selector valve accommodates hydraulic-driven attachments that operate either one or two ways. Wedge-style coupler enables swift changes of a wide range of buckets and attachments, such as hydraulic hammers, plate compactors, and augers.

Safe travels

No operator activation is required for high-speed travel. Track speeds automatically slow to low whenever a heavier load is encountered, then return to high when the load normalizes.

Designed for durability

Heavy-duty side shields deflect material and impacts, protecting boom/blade cylinders and drive motors. Single-pin swing-post increases boom rigidity. Reinforced D-channel side frames and heavy-duty X-frame help extend wear life.

Maintenance made easy

Hinged door provides wide-open access to the side-by-side oil cooler and radiator. Operator station tilts forward 50 degrees to reach the swing motor, hydraulic control valve, engine starter motor, and alternator. Extended service intervals allow the machine to work longer before maintenance is needed.

Make the most of your investment

Already own some John Deere attachments? Many models including buckets, hydraulic hammers, and augers also work on other compact machines so you can redefine fleet utilization — and your bottom line.



60 P-TIER COMPACT EXCAVATOR



MATCH YOUR TRACK TO THE APPLICATION

The choice is yours

Rubber tracks traverse virtually any terrain, including paved surfaces. Optional rubber grousers combine work-anywhere flexibility with steel-track serviceability. Steel tracks and steel tracks with rubber pads are also available.

Connected machines

John Deere construction equipment comes with in-base connectivity — free from subscriptions or annual renewals. Analyze critical machine data, track utilization, review diagnostic alerts, and more from **the John Deere Operations Center™**. The Operations Center also enables **John Deere Connected Support™**, which uses data from thousands of connected machines to proactively address issues before they arise. Your dealer can also remotely monitor machine health, diagnose problems, and even update machine software without a trip to the jobsite.*

*Availability varies by region and product. Options not available in every country.

60

P

60 P-TIER COMPACT EXCAVATOR SPECIFICATIONS

While general information, pictures, and descriptions are provided, some illustrations and text may include product options and accessories NOT AVAILABLE in all regions, and in some countries products and accessories may require modifications or additions to ensure compliance with the local regulations of those countries.

Engine		60 P-TIER	
Manufacturer and Model	Yanmar 4TNV98C-WHB	Displacement	3.32 L (203 cu. in.)
Non-Road Emission Standard	EPA Final Tier 4/EU Stage IV	Net Rated Power (ISO 9249)	39.6 kW (53 hp) at 2,000 rpm
Powertrain			
2-speed propel with automatic shift; each track independently driven by hydrostatic axial-piston motor connected to 2-stage planetary gear-reduction box			
Maximum Travel Speed	Slow: 2.9 km/h (1.8 mph) / Fast: 4.8 km/h (3.0 mph)		
Hydraulics			
Open-center, pilot-operated			Controls
Main Pumps	1 variable-displacement pump		2 hydraulic pilot-operated controls for boom, arm, bucket, swing, boom swing, travel, and auxiliary functions
Maximum Rated Flow	144 L/m (38.0 gpm)		
Auxiliary Maximum Rated Flow	91.5 L/m (24.2 gpm)		
Electrical			
Alternator Rating	55 amp		
Work Lights	2 halogen: 1 mounted on operator's station and 1 mounted on boom		
Undercarriage			
Track Shoe Width, Standard Configuration	400 mm (16 in.)		
Ground Pressure	1500-mm (4 ft. 11 in.) Standard Arm		1850-mm (6 ft. 1 in.) Long Arm (add counterweight)
	With Canopy	With Cab	With Canopy
With 400-mm (16 in.) Rubber Track	34 kPa (4.9 psi)	35 kPa (5.1 psi)	36 kPa (5.2 psi)
			With Cab
			36 kPa (5.2 psi)
Upperstructure			
Swing Speed, Right/Left	9.5 rpm		
Maximum Boom Swing Angle			
Left	80 deg.		
Right	60 deg.		
Swing Brake	Spring applied, hydraulically released, automatic, disc type		
Serviceability			
Refill Capacities			
Fuel Tank	120 L (31.7 gal.)	Refill Capacities (continued)	
Engine Coolant	7.7 L (2 gal.)	Engine Oil With Filter	11.2 L (3 gal.)
		Hydraulic Tank	80 L (21.1 gal.)
Operating Weights			
	1500-mm (4 ft. 11 in.) Standard Arm and 400-mm (12 in.) Track		1850-mm (6 ft. 1 in.) Long Arm and 400-mm (12 in.) Track
	With Canopy	With Canopy	With Cab
	Rubber	Steel	Rubber
With 745-kg (1,642 lb.) Counterweight;	6010 kg	6110 kg	6180 kg
762-mm (30 in.), 204-kg (450 lb.) Bucket;	(13,250 lb.)	(13,470 lb.)	(13,620 lb.)
Full Fuel Tank; and 75-kg (165 lb.) Operator			
Angle Blade	458 kg (1,010 lb.)	458 kg (1,010 lb.)	458 kg (1,010 lb.)
Counterweight			
Standard (including hardware)	745 kg (1,642 lb.)	745 kg (1,642 lb.)	745 kg (1,642 lb.)
Additional	270 kg (595 lb.)	270 kg (595 lb.)	270 kg (595 lb.)

Operating Dimensions		1500-mm (4 ft. 11 in.) Standard Arm	1850-mm (6 ft. 1 in.) Long Arm	1500-mm (4 ft. 11 in.) Standard Arm	1850-mm (6 ft. 1 in.) Long Arm
A Maximum Cutting Height		5.96 m (19 ft. 7 in.)	6.19 m (20 ft. 4 in.)	5.76 m (18 ft. 11 in.)	5.79 m (19 ft. 0 in.)
B Maximum Dumping Height		4.17 m (13 ft. 8 in.)	4.41 m (14 ft. 6 in.)		
C Maximum Digging Depth		3.77 m (12 ft. 4 in.)	4.12 m (13 ft. 6 in.)		
D Maximum Digging Reach		6.23 m (20 ft. 5 in.)	6.56 m (21 ft. 6 in.)		
E Minimum Boom Swing Radius		2.45 m (8 ft. 0 in.)	2.54 m (8 ft. 4 in.)*		
				F Transport Length	
				Digging Force (ISO), HCM Bucket (788.1-mm [31 in.] tip radius)	
				Arm	31.1 kN (6,990 lb.)
				Bucket	41.1 kN (9,240 lb.)
					27.0 kN (6,060 lb.)
					41.1 kN (9,240 lb.)

*With additional counterweight.

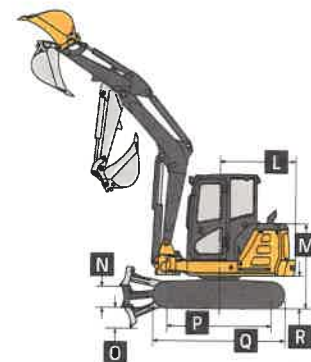
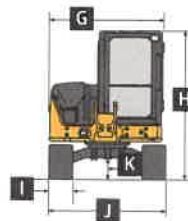
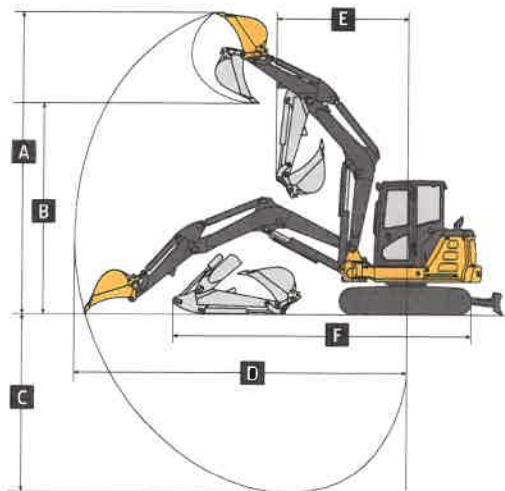

60 P-TIER COMPACT EXCAVATOR SPECIFICATIONS

60

P

While general information, pictures, and descriptions are provided, some illustrations and text may include product options and accessories NOT AVAILABLE in all regions, and in some countries products and accessories may require modifications or additions to ensure compliance with the local regulations of those countries.

Machine Dimensions <i>(see line art at bottom right of page 6)</i>		60 P-TIER	
G	Upperstructure Width	1.93 m (6 ft. 4 in.)	
H	Overall Height (canopy or cab)	2.54 m (8 ft. 4 in.)	
I	Track Width	400 mm (16 in.)	
J	Undercarriage Width	2.00 m (6 ft. 7 in.)	
K	Ground Clearance	325 mm (13 in.)	
L	Tail Swing Radius		
	With Standard Counterweight	1.30 m (4 ft. 3 in.)	
	With Additional Counterweight	1.41 m (4 ft. 8 in.)	
M	Engine Cover Height	1.60 m (5 ft. 3 in.)	
N	Maximum Blade Lift Above Ground	450 mm (18 in.)	
O	Maximum Blade Drop Below Ground	390 mm (15 in.)	
	Blade		
	Width	2.00 m (6 ft. 7 in.)	
	Height	420 mm (17 in.)	
P	Sprocket Center to Idler Center	1.99 m (6 ft. 6 in.)	
Q	Undercarriage Length	2.50 m (8 ft. 2 in.)	
R	Counterweight Clearance	620 mm (24 in.)	

Lift Capacities

Boldface type indicates hydraulically limited capacity; **lightface type** indicates stability-limited capacities, in kg (lb.). All lift capacities are based on ISO 10567 (with power boost). Lifting measurement from center of arm to bucket pin; with 400-mm (16 in.) track shoe and blade on ground; and situated on firm, level, uniform supporting surface. Total load includes weight of cables, hook, etc. Figures do not exceed 87 percent of hydraulic capacities or 75 percent of weight needed to tip machine.

Ground Level at 3.0-m (9 ft. 10 in.) Radius	Rubber Track and		Steel Track and		Rubber Track and		Steel Track and	
	Standard Counterweight Over Front	Over Side	Standard Counterweight Over Front	Over Side	Extra Counterweight Over Front	Over Side	Extra Counterweight Over Front	Over Side
1500-mm (4 ft. 11 in.) Standard Arm and Cab	3880 kg (8,550 lb.)	1500 kg (3,310 lb.)	3880 kg (8,550 lb.)	1520 kg (3,350 lb.)	3880 kg (8,550 lb.)	1690 kg (3,730 lb.)	3880 kg (8,550 lb.)	1720 kg (3,790 lb.)
1850-mm (6 ft. 1 in.) Long Arm and Cab	3810 kg (8,400 lb.)	1480 kg (3,260 lb.)	3810 kg (8,400 lb.)	1500 kg (3,310 lb.)	3810 kg (8,400 lb.)	1680 kg (3,700 lb.)	3810 kg (8,400 lb.)	1700 kg (3,750 lb.)
1500-mm (4 ft. 11 in.) Standard Arm and Canopy	3880 kg (8,550 lb.)	1420 kg (3,130 lb.)	3880 kg (8,550 lb.)	1420 kg (3,130 lb.)	3880 kg (8,550 lb.)	1620 kg (3,570 lb.)	3880 kg (8,550 lb.)	1620 kg (3,570 lb.)
1850-mm (6 ft. 1 in.) Long Arm and Canopy	3820 kg (8,420 lb.)	1400 kg (3,090 lb.)	3820 kg (8,420 lb.)	1400 kg (3,090 lb.)	3820 kg (8,420 lb.)	1600 kg (3,530 lb.)	3820 kg (8,420 lb.)	1610 kg (3,550 lb.)

Additional equipment

Key: ● Standard ▲ Optional or special

See your John Deere dealer for further information.

60 P Engine

- Meets EPA Final Tier 4/EU Stage IV emissions
- Auto shutdown
- Engine coolant to -37 deg. C (-34 deg. F)
- Engine preheater
- Fan guard
- Fuel/water separator
- Full-flow oil filter
- Isolation mounted
- Key start switch with electric fuel shutoff
- Single dry-type air filter

Hydraulic System

- Auto-idle
- Auxiliary function right-hand pilot-lever control
- Auxiliary hydraulic lines with quick-couplers to end of boom
- Auxiliary return-flow selector valve
- Axial-piston swing motor
- Boom-swing foot control
- Excavator-to-backhoe control pattern change valve
- Closed center load sensing with 1 variable-displacement pump
- Hydraulic pilot-operated controls for boom, arm, bucket, swing, boom swing, blade, travel, and auxiliary functions
- Wet-disc swing brake

Undercarriage

- Planetary final drive
- Propel motor shield
- 2-speed axial-piston propel motors
- Rubber track, 400 mm (16 in.)

60 P Undercarriage (continued)

- ▲ Steel track, 400 mm (16 in.) with triple semi-grousers
- ▲ Rubber crawler pad, 400 mm (16 in.)

Upperstructure

- 360-deg. rotation
- Counterweight, 745 kg (1,642 lb.)
- Hinged service-access doors
- Toolbox
- ▲ ROPS/TOPS/FOPS (canopy)
- ROPS/TOPS/FOPS (cab) with air conditioning and heater
- Vandal protection for service doors, fuel cap, and toolbox
- Reduced-tail-swing configuration

Front Attachments

- Arm, 1500 mm (4 ft. 11 in.)
- ▲ Long arm, 1850 mm (6 ft. 1 in.), includes additional 270-kg (595 lb.) counterweight
- Articulation hose shield
- Backfill blade, 2.00 m (6 ft. 7 in.)
- ▲ Hydraulic angle backfill blade
- Boom, 2.965 m (9 ft. 9 in.)
- Mechanical quick-coupler
- ▲ Augers: Planetary / Chain drive / Bits / Bit adapters
- ▲ Clamp
- ▲ Hammers: Points / Tools
- ▲ Quick-coupler buckets: Bucket teeth / Ditching / Heavy-duty

Operator's Station

- Horn
- Hour meter

60 P Operator's Station (continued)

- Instrumentation lights
- Mode selectors (illuminated): Power mode (1) / Economy mode (1)
- Monitor system: Preheat indicator / Engine oil pressure indicator with alarm / Alternator voltage indicator / Fuel gauge and low-fuel-level indicator / Engine coolant temperature gauge and engine coolant temperature indicator with alarm / Hour meter / Work lights indicator
- Motion alarm with cancel switch
- Work lights switch
- Propel levers and foldable pedals
- 2 travel speeds with automatic shifting
- Seat belt, 51 mm (2 in.), retractable
- ▲ Seat belt, 76 mm (3 in.), retractable
- ▲ Vinyl seat with fore/aft adjustment
- Suspension seat (cloth)
- ▲ Front screen
- ▲ Rear secondary exit kit

Electrical

- 12-volt accessory outlet
 - Alternator, 55 amp
 - Low-maintenance battery
 - Blade-type multi-fused circuits
 - Positive-terminal battery covers
 - ▲ JDLink™ connectivity hardware and John Deere Operations Center™ account
- ### Lights
- Work lights: Halogen / 1 mounted on operator's station / 1 mounted on boom

Net engine power is with standard equipment including air cleaner, exhaust system, alternator, and cooling fan at test conditions per ISO 9249. These machines are not equipped with spark-arrestor mufflers. Usage in forestry applications is not recommended. Specifications and design subject to change without notice. Wherever applicable, specifications are in accordance with SAE standards. Except where otherwise noted, these specifications are based on a cab unit with standard arm, 0.19-m³ (6.8 cu. ft.) bucket, 400-mm (16 in.) rubber track, 745-kg (1,642 lb.) counterweight, full fuel tank, and 79-kg (175 lb.) operator.



JOHN DEERE



POWERTILT®

Next Generation

Tilt Any Bucket
or Attachment
up to 180 Degrees

HELAC®

Parker

THE NEXT GENERATION OF TILTING

INTEGRAL ROTARY UNION FOR COUPLER

- Eliminates hoses and hose guards
- Simplified hose routings

REDUCED WEIGHT

- Better stability
- Decreased fuel costs

IMPROVED HOLDING FORCE

- Increased productivity

HARDENED SEAL AND BEARING SURFACES

- Reduced cost of ownership
- Longer life

INTEGRATED CROSS-PORT RELIEF VALVE

- Overload protection

VERSATILE COUPLER CONFIGURATIONS

- Available with common couplers
- Adaptable to a variety of buckets and attachments

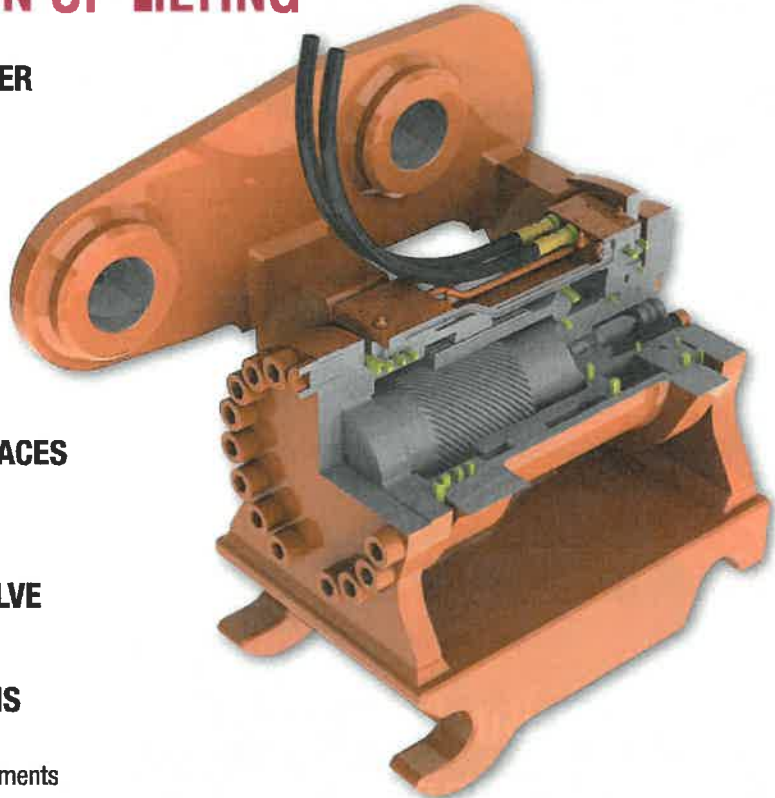

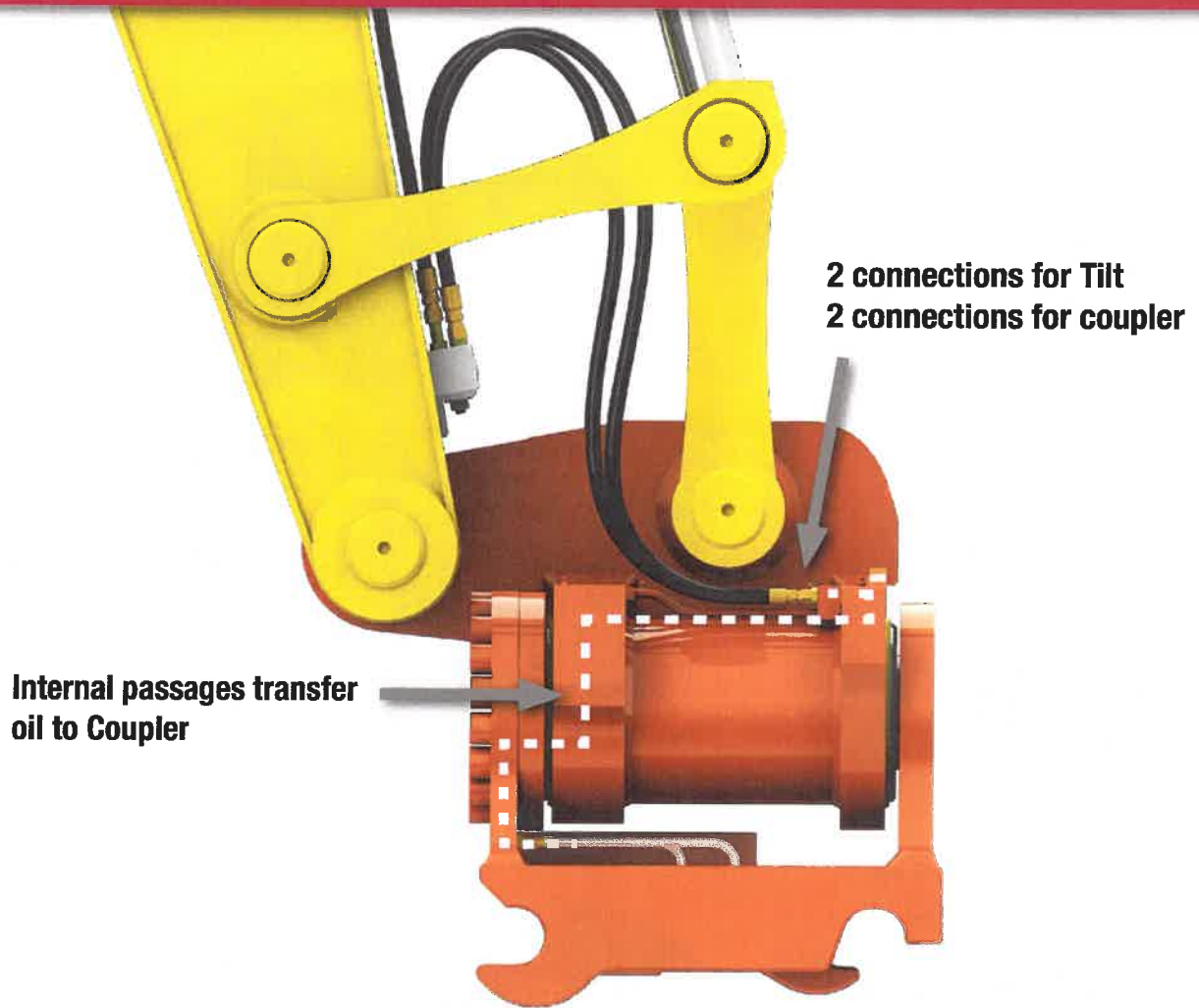

POWERTILT SPECIFICATIONS		4.5 **	030	050	070	100	180	240	300	465
Maximum Machine Weight	kg lbs	1 800 4 000	3 000 6 600	5 000 11 000	7 000 15 500	10 000 22 000	18 000 40 000	24 000 53 000	32 000 70 000	50 000 110 000
Approximate PowerTilt Weight*	kg lbs	34 75	38 84	56 123	96 211	137 302	253 557	357 785	450 990	574 1 260
Total Tilt		180°	180°	180°	180°	180°	120°	120°	120°	120°
Driving Torque										
Nm @ 207 bar		930	1 630	2 600	4 375	6 650	13 300	17 875	24 900	44 300***
in-lbs @ 3000 psi		8 200	14 400	22 900	38 700	58 800	117 600	158 200	220 400	392 000
Holding Torque										
Nm @ 225 bar		2 470	6 425	9 350	14 850	20 450	40 725	53 100	70 330	111 800***
in-lbs @ 3250 psi		21 900	56 900	82 800	131 400	180 900	360 400	470 000	622 400	989 500
Required Oil Flow	l/min GPM	3-7 1-2	6-19 1.7-5	9-28 2.5-7.5	13-38 3.3-10	19-58 5-15	26-78 7-21	35-105 9-28	47-142 13-38	54-162 16-48
Circuit Pressure Max	bar psi	207 3 000	207 3 000	207 3 000	207 3 000	207 3 000	207 3 000	207 3 000	207 3 000	310 4 500
Oil Passages for Quick Coupler		0	2	2	2	2	2	2	2	2

* Weight with side plates, bosses and feet, no coupler ** Includes integrated pilot operated check valve as standard
 *** PT-465 Nm @ 310 bar (Driving Torque) and PT-465 Nm @ 325 bar (Holding Torque)

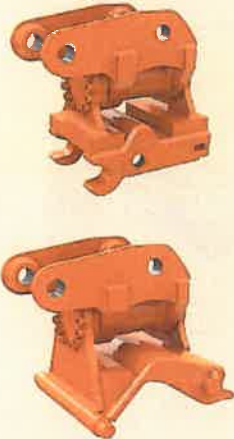
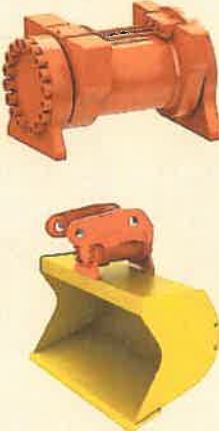

POWERTILT CONFIGURATIONS

PT Series	PTS Series	PTA/PTS Blank Series	Custom Designs
			

© 2017 Parker - Helac. All Rights Reserved. Patents — USA: 5,447,095; EP: 0 697 526; Europe: 2327840



Finish Grading



Underground Utilities



Ditch Cleaning



Metering Fill Material



Demolition



Brushcutting



Trench Safety



Ripping Tooth



Landscaping

BIGFOOT XD TRENCHER



HEAVY DUTY DANGER BAR

Increased durability. Reduces crumpler flexing, producing a better finish.

BARREL & SPOIL AUGER

Increased trencher productivity by removing spoil fast and efficiently.

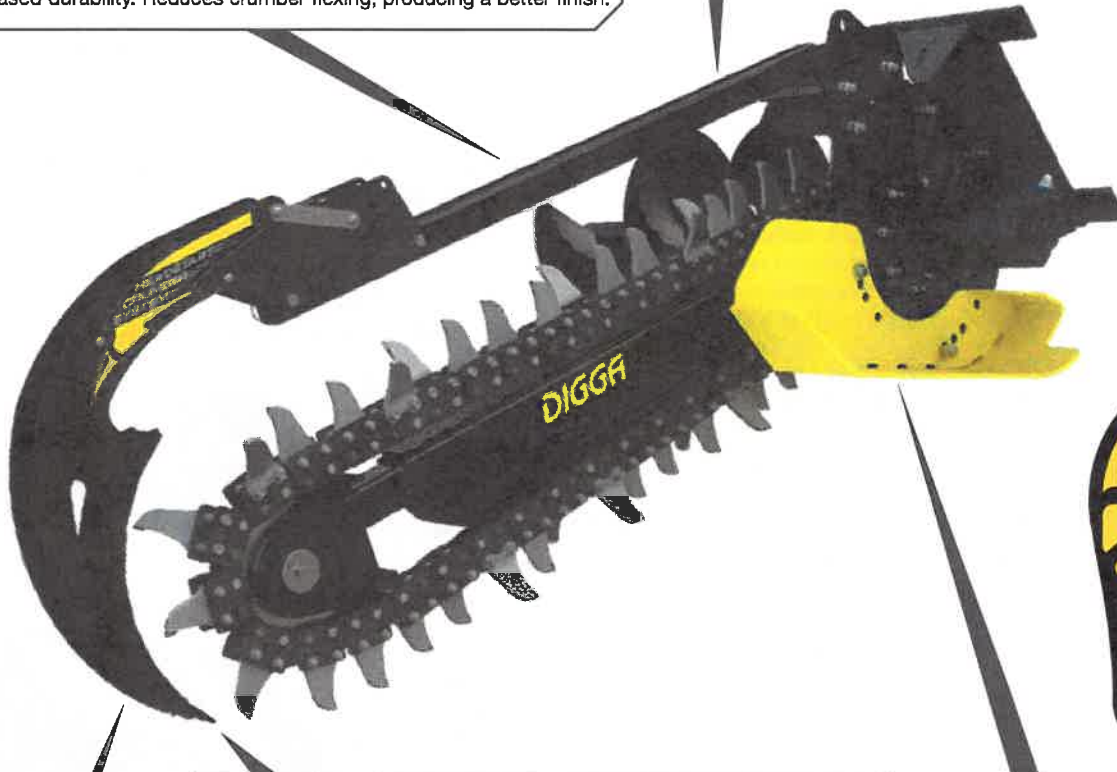

HEAVY DUTY SCRAPER SHOE

The scraper shoe is now made from steel for increased durability.

HEAD START CRUMBER

Start trenching with the crumber in the ground. Eliminates the need to step out of the machine once the trench is started, saving you time & money.

VISIBLE FOOT DESIGN

Foot can be seen from the cab enabling the operator to see when it's in the correct trenching position eliminating the need of a spotter. The design also feeds overburden back onto the chain, transferring it to the spoil auger for a cleaner clearer work side of the trench.



WHY A TRENCHER OVER A BUCKET?



EFFICIENT

NARROWER TRENCHES TO GREATER DEPTHS CAN BE ACHIEVED



FASTER

A TRENCHER WILL CUT GROUND FASTER THAN AN EXCAVATOR BUCKET AS IT CUTS IN A CONTINUOUS MOVEMENT



EASIER

THE SPOIL IS EXCAVATED MORE FINELY WITH A TRENCHER SO THE TRENCH CAN BE EASILY BACKFILLED WITH BETTER COMPACTION. AS THE SPOIL IS MUCH FINER IT IS SUITABLE FOR THE BEDDING OF PIPES AND CABLES ETC



ACCURATE

VARIOUS SIZE TRENCH WIDTHS MEANS YOU DON'T HAVE TO EXCAVATE ANY MORE THAN IS REQUIRED. LEAVES THE BOTTOM OF THE TRENCH FLAT AND CLEAN



COST EFFECTIVE

DIGS 3 TO 4 TIMES FASTER THAN AN EXCAVATOR/BACKHOE WITH LESS MESS. SPOIL IS EASIER TO BACKFILL WITH BETTER COMPACTION

BIGFOOT XD TRENCHER



REVOLUTIONARY HEADSTART CRUMBER SYSTEM...

An evolution from our Bigfoot Trencher with a greater trench digging depth of up to 60". Fitted with a patent pending Head Start Crumber system, quality Digga Planetary Drive & Eaton Hydraulic Motor, 4 position-adjustable skid foot and single spoil removal auger.

The Head Start Crumber system (patent pending) lets you begin trenching with the crumber down and saves you time by not having to get out of your machine to reset it.

Our unique design also gives the operator consistent digging depth for efficient spoil removal and finely crumbled spoil for effective compaction back into the trench. This provides minimal ground disturbance to surrounding conditions and results in a cleaner finish.

FEATURES

- Adjustable skid foot features 4 preset digging depths. Highly visible and can be seen from the cab. No spotter required
- Up to 60" digging depth and 12" digging width with a 2" chain
- Heavy duty Crumber with steel scraper shoe
- Head Start Crumber System (patent pending) - Begin trenching with the crumber down and save time by not having to get out of your machine
- XD range features a compact, yet powerful Digga planetary drive while high flow XD models come with a 6K Eaton hydraulic motor
- XD 1200 comes with 3 different chain options - Earth, Combo, Diggatac
- High flow XDs include 2 different Chain options - Combo & Diggatac
- Frame can be side shifted for digging close to permanent structures

IDEAL USE

- Pipe laying for irrigation, underground power and communications, road repairs and general construction

MACHINE SUITABILITY

- Excavators up to 8 ton, Skid Steer Loaders

BIGFOOD XD

MODEL	XD 900	XD 1200	XD 1200 HF	XD 1500 HF
CUTTING DEPTH	up to 36"	up to 48"	up to 48"	up to 60"
CUTTING WIDTHS	6" / 8" / 10" / 12"	6" / 8" / 10" / 12"	6" / 8" / 10" / 12"	6" / 8" / 10" / 12"
FOOT DEPTH PRESETS	18" / 24" / 30" / 36"	24" / 32" / 40" / 48"	24" / 32" / 40" / 48"	30" / 40" / 48" / 60"
RECOMMENDED FLOW - GPM	16 - 30	16 - 30	28 - 45	28 - 45
MOTOR TYPE	2K Bell EATON	2K Bell EATON	6K Bell EATON	6K Bell EATON
MAX PRESSURE (DO NOT EXCEED)	3500 ps @ 16 gpm		3500 psi @ 34 gpm	
MAX FLOW (DO NOT EXCEED)	25 gpm @ 2900 psi		45 gpm @ 2800 psi	
MAX CONTINUOUS POWER	34 hp	34 hp	67 hp	67 hp
LENGTH	76"	100"	100"	106"
HORIZONTAL HEIGHT	26"	31"	31"	33"
WIDTH	48"	48"	48"	45"
WEIGHT - WT 6" CHAIN	855 lbs	893 lbs	935 lbs	1016 lbs



For detailed specifications on the complete range available contact your local professional Digga dealer

TRENCHER DIG DEPTH SETTINGS

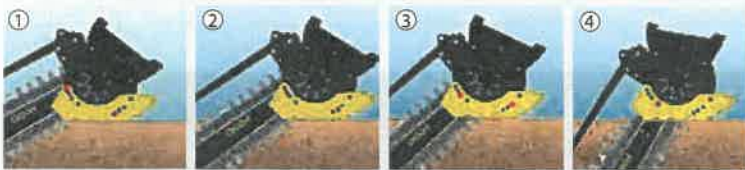

DEPTH SETTING	XD 900	XD 1200	XD 1200 HF	XD 1500 HF
1	18"	24"	24"	30"
2	24"	32"	32"	40"
3	30"	40"	40"	48"
4	36"	48"	48"	60"

TRENCHER CHAIN OPTIONS



EARTH (STD ONLY)	COMBINATION	DIGGATAC
Cup tooth on every second station	Combination of earth & tungsten teeth	Full tungsten teeth on every station
Best for soft clean ground with no floaters or tree roots	Suitable for most applications. Cuts through hard soils, roots, soft shale & rocky ground	Best for rocky hard shale, asphalt and frozen ground