



State of West Virginia
 Department of Administration
 Purchasing Division
 2019 Washington Street East
 Post Office Box 50130
 Charleston, WV 25305-0130

Solicitation

NUMBER
PTR13059

PAGE
1

ADDRESS CORRESPONDENCE TO ATTENTION OF:
BETH COLLINS 304-558-2157

RFQ COPY

TYPE NAME/ADDRESS HERE

VENDOR

SHIP TO

DIVISION OF PUBLIC TRANSIT
 KANAWHA VALLEY REGIONAL TRANS
 1550 FOURTH AVENUE
 CHARLESTON, WV
 25325 304-343-3840

DATE PRINTED
03/21/2014

BID OPENING DATE: 04/17/2014

BID OPENING TIME 1:30PM

LINE	QUANTITY	UOP	CAT NO	ITEM NUMBER	UNIT PRICE	AMOUNT
ADDENDUM NO. 01						
THIS ADDENDUM IS ISSUED TO MODIFY THE ORIGINAL SOLICITATION PER THE ATTACHED DOCUMENTATION.						
0001	1	EA		557-05		
176" WHEELBASE BUSES (18 PASSENGER CUTAWAYS)						
***** THIS IS THE END OF RFQ PTR13059 ***** TOTAL:						

SIGNATURE		TELEPHONE	DATE
TITLE	FEIN	ADDRESS CHANGES TO BE NOTED ABOVE	

WHEN RESPONDING TO SOLICITATION, INSERT NAME AND ADDRESS IN SPACE ABOVE LABELED 'VENDOR'

SOLICITATION NUMBER: PTR13059**Addendum Number: 01**

The purpose of this addendum is to modify the solicitation identified as ("Solicitation") to reflect the change(s) identified and described below.

Applicable Addendum Category:

- Modify bid opening date and time
- Modify specifications of product or service being sought
- Attachment of vendor questions and responses
- Attachment of pre-bid sign-in sheet
- Correction of error
- Other

Description of Modification to Solicitation:

This addendum is to provide answers to technical questions and approved equals.

The bid date will remain April 17, 2014 at 1:30 PM EST.

Additional Documentation: Documentation related to this Addendum (if any) has been included herewith as Attachment A and is specifically incorporated herein by reference.

Terms and Conditions:

1. All provisions of the Solicitation and other addenda not modified herein shall remain in full force and effect.
2. Vendor should acknowledge receipt of all addenda issued for this Solicitation by completing an Addendum Acknowledgment, a copy of which is included herewith. Failure to acknowledge addenda may result in bid disqualification. The addendum acknowledgement should be submitted with the bid to expedite document processing.

ATTACHMENT A

TECHNICAL QUESTIONS/ APPROVED EQUALS ON PTR13059

TECHNICAL QUESTIONS/APPROVED EQUALS

- 3.9.3 In lieu of Sound Off brand lights, please accept our standard Optronics brand of exterior LED lights, as described in the attached literature.
Approved. See Appendix A attached.
- 3.9.4a In lieu of Gustafson brand lights, please accept our standard Optronics brand of interior LED lights, as described in the attached literature.
Approved. See Appendix A attached.
- 3.13.4b Please accept our standard tread depth of 11" in lieu of 12".
Approved. Please note this change on the floorplans submitted for each class this affects.
- 3.19.9 This section calls for windows on both sides of the rear emergency door, but since the basic bus does not have a rear emergency door, this section should call for a large rear window (a minimum of 30" high and 48" wide) with an emergency egress feature. The optional rear emergency door described in Class B, C, D, and E floor plans should include the twin rear windows feature.
Amend specifications to have a rear emergency egress window in the absence of the rear exit door on Classes A, F, G, and H.
- 3.23 No wool blankets are called for, which were required in the 158" bid. Is this correct?
No. WVDPT would like 2 wool blankets in addition to the two Mylar blankets on each unit for emergency purposes.
- 4.3, 4.4, 4.5, 4.6, and 4.7 This option calls for the addition of a 3rd wheel chair position. In the past the division has received the attached floorplan labeled Front Lift Floorplan. It only has two wheelchair positions but maximizes ambulatory passenger capacity which we believe agencies are looking for and are used to. Would this floorplan be acceptable for the extended Body Length Front Lift Option?
If the 3rd wheelchair position is required please advise as to the Number of Fixed Ambulatory Passenger Seats and Foldaway Ambulatory seats required or provide sample floorplan.
Two wheelchair positions are all that are required for our purposes. Classes D, E, F, and G requested the extended body to accommodate the front lift position and front to back orientation of securement spaces. 4.7 should have the extended length and the side by side orientation of wheelchair securement positions with a rear lift. Please see Appendix B.

TECHNICAL QUESTIONS/ APPROVED EQUALS ON PTR13059

CLARIFICATIONS/ CORRECTIONS

THE SPECIFICATIONS READ:

4.7 Class G (extended body, front lift , full bus paint, armrests, bike rack mounting prep, two additional seats) Vehicles identified as Class H vehicles must meet the mandatory requirements listed in section 3 and the mandatory requirements of Class A, with the exception that Class G vehicles must have extended body, armrests, full bus paint, bike rack mounting prep, and two additional seats, if possible, as listed below in 4.7.1 through 4.7.6.

4.6.1 Extended length with front lift option--Increase body length to 301" +/- and mount on 186" wheelbase chassis to accommodate front lift configuration and additional wheelchair position per attached floor plan.

4.6.2 A flip up armrest for each passenger aisle seat shall be installed. **Vendor should submit product description, warranty information, and product literature with bid, but must submit within 48 hours of request.**

4.6.3 Full Bus Body Paint-- The vendor shall supply full-bus body paint for each vehicle of this class ordered. **Vendor must supply a sample paint chart within 48 hours of request.** The West Virginia Division of Public Transit will select the colors for each vehicle to be painted.

4.6.4 Bike rack mounting preparation, including any needed bracing or predrilled holes. The specifics of the type of rack to be mounted will be discussed with the agency during the manufacturing process.

4.7 Class H (extended body, armrests, full bus paint, bike rack mounting prep, overhead luggage, and high back seats) Vehicles identified as Class H vehicles must meet the mandatory requirements listed in section 3 and the mandatory requirements of Class A, with the exception that Class I vehicles must have extended body (Class H gets REAR LIFT), armrests, full bus paint, bike rack mounting prep, overhead luggage rack, and high back seats as listed below in 4.7.1 through 4.7.6.

4.7.1 Extended length --Increase body length to 301" +/- and mount on 186" wheelbase chassis. **Class H gets REAR LIFT**

4.7.2 A flip up armrest for each passenger aisle seat shall be installed. **Vendor should submit product description, warranty information, and product literature with bid, but must submit within 48 hours of request.**

4.7.3 Full Bus Body Paint-- The vendor shall supply full-bus body paint for each vehicle of this class ordered. **Vendor must supply a sample paint chart within 48 hours of request.** The West Virginia Division of Public Transit will select the colors for each vehicle to be painted.

TECHNICAL QUESTIONS/ APPROVED EQUALS ON PTR13059

4.7.4 Bike rack mounting preparation, including any needed bracing or predrilled holes. The specifics of the type of rack to be mounted will be discussed with the agency during the manufacturing process.

4.7.5 Interior overhead luggage racks-- **Vendor should submit product description, warranty information, and product literature with bid, but must submit within 48 hours of request.**

4.7.6 Substitute high back for mid high passenger seats. **Vendor should submit product description, warranty information, and product literature with bid, but must submit within 48 hours of request.**

PLEASE CORRECT NUMBERING TO READ AS FOLLOWS and delete the additional wheelchair position on 4.7.1, for a total of two wheelchair securement positions:

4.7 **Class G (extended body, front lift , full bus paint, armrests, bike rack mounting prep, two additional seats)** Vehicles identified as Class H vehicles must meet the mandatory requirements listed in section 3 and the mandatory requirements of Class A, with the exception that Class G vehicles must have extended body, armrests, full bus paint, bike rack mounting prep, and two additional seats, if possible, as listed below in 4.7.1 through 4.7.6.

4.7.1 Extended length with front lift option--Increase body length to 301" +/- and mount on 186" wheelbase chassis to accommodate front lift configuration.

4.7.2 A flip up armrest for each passenger aisle seat shall be installed. **Vendor should submit product description, warranty information, and product literature with bid, but must submit within 48 hours of request.**

4.7.3 Full Bus Body Paint-- The vendor shall supply full-bus body paint for each vehicle of this class ordered. **Vendor must supply a sample paint chart within 48 hours of request.** The West Virginia Division of Public Transit will select the colors for each vehicle to be painted.

4.7.4 Bike rack mounting preparation, including any needed bracing or predrilled holes. The specifics of the type of rack to be mounted will be discussed with the agency during the manufacturing process.

4.8 **Class H (extended body, armrests, full bus paint, bike rack mounting prep, overhead luggage, and high back seats)** Vehicles identified as Class H vehicles must meet the mandatory requirements listed in section 3 and the mandatory requirements of Class A, with the exception that Class I vehicles must have extended body (Class H gets REAR LIFT), armrests, full bus paint, bike rack mounting prep, overhead luggage rack, and high back seats as listed below in 4.7.1 through 4.7.6.

4.8.1 Extended length --Increase body length to 301" +/- and mount on 186" wheelbase chassis. **Class H gets REAR LIFT**

TECHNICAL QUESTIONS/ APPROVED EQUALS ON PTR13059

4.8.2 A flip up armrest for each passenger aisle seat shall be installed. **Vendor should submit product description, warranty information, and product literature with bid, but must submit within 48 hours of request.**

4.8.3 Full Bus Body Paint-- The vendor shall supply full-bus body paint for each vehicle of this class ordered. **Vendor must supply a sample paint chart within 48 hours of request.** The West Virginia Division of Public Transit will select the colors for each vehicle to be painted.

4.8.4 Bike rack mounting preparation, including any needed bracing or predrilled holes. The specifics of the type of rack to be mounted will be discussed with the agency during the manufacturing process.

4.8.5 Interior overhead luggage racks-- **Vendor should submit product description, warranty information, and product literature with bid, but must submit within 48 hours of request.**

4.8.6 Substitute high back for mid high passenger seats. **Vendor should submit product description, warranty information, and product literature with bid, but must submit within 48 hours of request.**

*** Are mudflaps required on all wheels? This was section 3.21 in the 158" bid, but is missing in this bid.

Mudflaps are required for all wheels.

*** Previously there was discussion to add a manual engagement switch for the fast idle system. This requirement was not in the specifications. Please advise if this will be a requirement on all classes or not.

Please see 3.14g, which references the "manual 'high idle on' switch" on the ILIS.

Please add wifi capability to all of the Classes.

Please find the floorplans that were inadvertently omitted on the original specifications attached at Appendix C.

Please find clean bid forms attached under Appendix D.

TECHNICAL QUESTIONS/ APPROVED EQUALS ON PTR13059

Appendix A

optronics®

LED TRUCK & TRAILER LIGHTING

STL43 REFLEX FLANGE SERIES 4" Round Sealed LED Lights with Reflex Mounting Flange

- Sonically sealed, waterproof
- Flange mount for security, theft reduction
- Accepts standard PL-3 connector
- Reflex flange meets SAE A for reflector

BULK P/N	POLYPACK P/N	DESCRIPTION	QTY
RED STOP/TURN/TAIL LIGHT - 10 DIODES			
STL43RBX	STL43RBXP	12V, red reflex flange, gasket	10
STL43RBHX	-	12V, red reflex flange, hard wire, gasket	10
YELLOW PARKING/TURN SIGNAL - 10 DIODES			
STL43ABX	STL43ABXP	12V, yellow reflex flange, gasket	10
ACCESSORIES			
A45PB	A45PBP	Pigtail, 3-wire	100
A47PB	A47PBP	Right angle pigtail, 3-wire	100

FMVSS	Red S T I; Yellow I6 P; Reflex A
MATERIALS	Polycarbonate lens and housing
VOLT/AMP	Red: 12.8VDC - .413 Stop/Turn, .026A Tail Yellow: 12.8VDC - .310 Turn, .046A Parking
WT/DIMS	.397 lbs. / 5.75" x 5.75" x 1.625"
WARRANTY	Lifetime LED Warranty

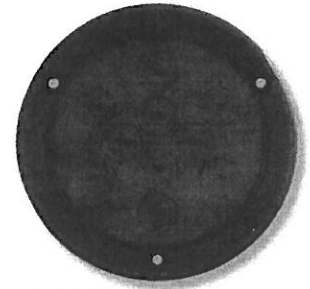

STL43RBX

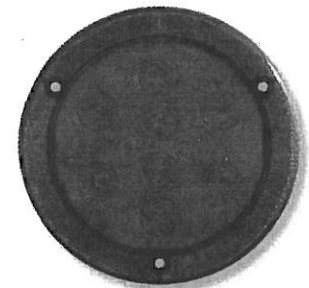

STL43ABX

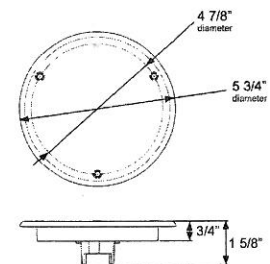

HOLE CUT-OUT: 4.5"

800-364-5483 / 918-683-9514
www.optronicsinc.com



optronics®

LED TRUCK & TRAILER LIGHTING

BUL11CBX 4" Round Sealed Clear DOT LED Back-Up Light

- Sonically sealed, waterproof
- Certified for back-up light function when installed as pair in two-lamp system [SAE (2)R]
- Flange features white reflex

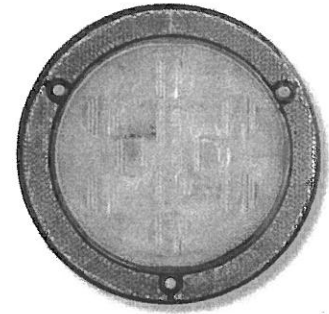

BULK P/N	POLYPACK P/N	DESCRIPTION	QTY
CLEAR BACK-UP LIGHT WITH REFLEX - 10 DIODES			
BUL11CBX	BUL11CBXP	12V	10
ACCESSORIES			
A45CB	A45CBP	Pigtail, 2-wire	100
A49PB	A49PBP	Right angle pigtail, 2-wire	100

FMVSS	(2) R
MATERIALS	Polycarbonate lens and housing
VOLT/AMP	12.8VDC - 0.26A
WT/DIMS	.353 lbs. / 5.75" x 5.75" x 1.625"
WARRANTY	Lifetime LED Warranty

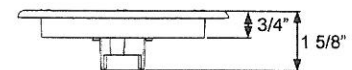
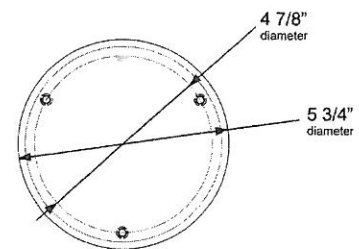

HOLE CUT-OUT: 4.5"

800-364-5483 / 918-683-9514
www.optronicsinc.com





LED TRUCK & TRAILER LIGHTING

MCL66 SERIES
Sealed LED Surface Mount
Marker/Clearance Lights

- Sonically sealed, waterproof
- Surface mount, mounts on 3" centers
- Includes both lead and ground wire

BULK P/N	POLYPACK P/N	DESCRIPTION	QTY
YELLOW - 6 DIODES			
MCL66AB	MCL66ABP	12V	20
MCL66APG	-	12V, .180 male bullets	20
MCL66A24B	MCL66A24BP	24V	20
MCL66CAB	-	12V, clear lens	20
RED - 6 DIODES			
MCL66RB	MCL66RBP	12V	20
MCL66RPG	-	12V, .180 male bullets	20
MCL66R24B	MCL66R24BP	24V	20
MCL66CRB	-	12V, clear lens	20
ACCESSORIES			
BK66DB	BK66DBP	Armored base, die cast metal	50
A66GB	A66GBP	Mounting gasket, black	100

FMVSS P2
MATERIALS MCL66 Polycarbonate lens and housing
 BK66DB Aluminum
VOLT/AMP 12.8VDC - 0.057A
WT/DIMS MCL66 .088 lbs. / 4" x 1" x 1.125"
 BK66DB .132 lb. / 4.25" x 1.125" x 1.688"
WARRANTY Lifetime LED Warranty

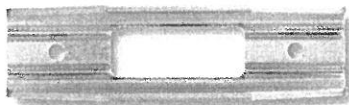
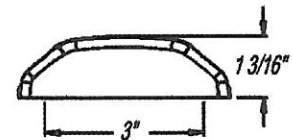
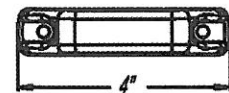
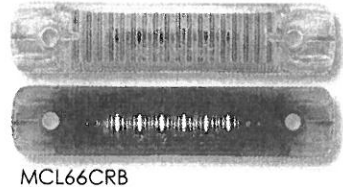
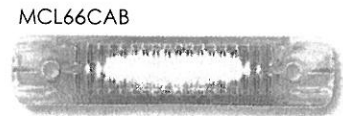

BK66DB

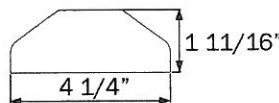
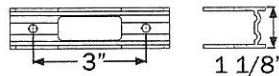

800-364-5483 / 918-683-9514
 www.optronicsinc.com



optronics® LED TRUCK & TRAILER LIGHTING

MCL48 SERIES LED Intermediate Side Marker Light with Supplemental Mid-Ship Turn

- Sonically sealed, waterproof
- Surface mount, mounts on 4-13/16" centers
- Includes both lead and ground wires

BULK P/N	POLYPACK P/N	DESCRIPTION	QTY
YELLOW - 16 DIODES			
MCL48AB	MCL48ABP	Light	20
MCL48CAB	-	Light, clear lens	20
ACCESSORIES			
A48CB	A48CBP	Chrome bezel	50

FMVSS	P2
MATERIALS	Polycarbonate lens and housing
VOLT/AMP	12.8VDC - Side marker .074A; Turn signal .248A
WT/DIMS	.221 lbs. / 6" x 2.25" x 1.375"
WARRANTY	Lifetime LED Warranty

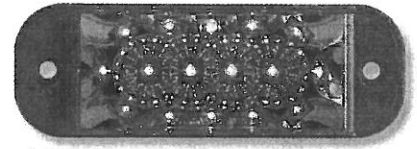

MCL48AB

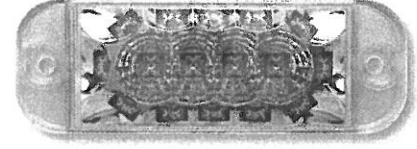

MCL48CAB

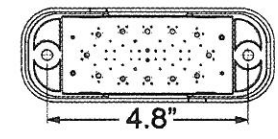
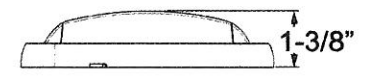
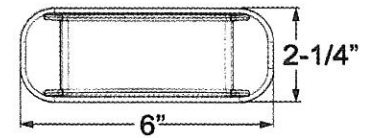

optronics® LED TRUCK & TRAILER LIGHTING

CBL22 SERIES Sealed LED Triangular Cab/Clearance Light



- Sonically sealed, waterproof
- Design includes lead and ground wire
- Mounting gasket included



CBL22AB

BULK P/N	POLYPACK P/N	DESCRIPTION	QTY
YELLOW - 15 DIODES			
CBL22AB	CBL22ABP	Cab light	50
CBL22CAB	-	Cab light, clear lens	50

FMVSS P2 PC
MATERIALS Polycarbonate lens and housing
VOLT/AMP 12.8VDC - 0.107A
WT/DIMS .176 lbs. / 3.5" x 2.75" x 1.688"
WARRANTY Lifetime LED Warranty

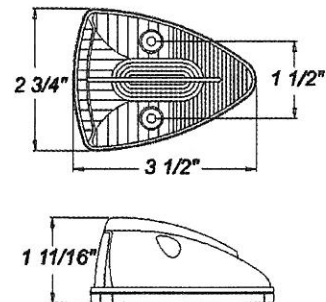

optronics®

LED TRUCK & TRAILER LIGHTING

ILL70/71 SERIES Opti-Brite™ LED Sealed Interior Strip Lights for Surface Mount



- Low profile, slimline lights – only 1" wide by 5/8" thick
- Hard wired design includes both lead and ground wires
- Select from 9-inch and 16-inch models
- Sealed, waterproof

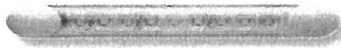

ILL70CB

BULK P/N	POLYPACK P/N	DESCRIPTION	QTY
9" STRIP LIGHT - 9 DIODES			
ILL70CB	ILL70CBP	Strip light	20/10
ILL70CSB	-	Strip light with on/off switch	10
ILL70CBAWN	-	Strip light with wedge base	10
ILL70ABAWN	-	Amber strip light with wedge base	10

Raw lumen output: 189 lm

Effective lumen output: 171 lm

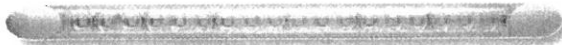
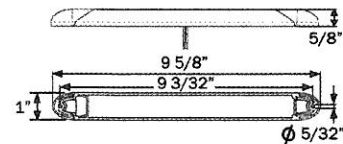

ILL71CB

BULK P/N	POLYPACK P/N	DESCRIPTION	QTY
16" STRIP LIGHT - 18 DIODES			
ILL71CB	ILL71CBP	Strip light	20/10
ILL71CSB	-	Strip light with on/off switch	10
ILL71CBAWN	-	Strip light with wedge base	10
ILL71ABAWN	-	Amber strip light with wedge base	10

Raw lumen output: 370 lm

Effective lumen output: 342 lm

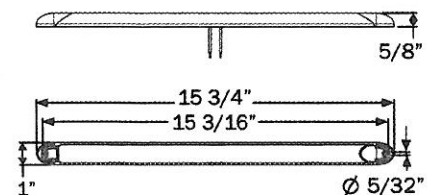

MATERIALS	Polycarbonate lens and housing
VOLT/AMP	ILL70: 12.8VDC - .150A ILL71: 12.8VDC - .300A
WT/DIMS	ILL70: .154 lb. / 9.625" x 1" x .625" ILL71: .187 lb. / 15.75" x 1" x .625"
WARRANTY	Lifetime LED Warranty

800-364-5483 / 918-683-9514
www.optronicsinc.com



optronics®

LED TRUCK & TRAILER LIGHTING

ILL31CB LED Low Profile Dome Light

- Low profile dome light for semi-recess mount
- Durable steel housing and replaceable polycarbonate lens
- Hard wired design includes power and ground wires

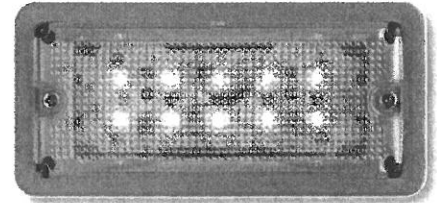

BULK P/N	POLYPACK P/N	DESCRIPTION	QTY
DOMELIGHT - 10 DIODES			
ILL31CB	ILL31CBP	Dome light, standard LED	10

Raw lumen output: 70 lm
Effective lumen output: 53 lm

MATERIALS Polycarbonate lens, plated steel housing
VOLT/AMP 12.8VDC - .024A
WT/DIMS .243 lb. / 5.375" x 2.75" x .938"
WARRANTY Lifetime LED Warranty

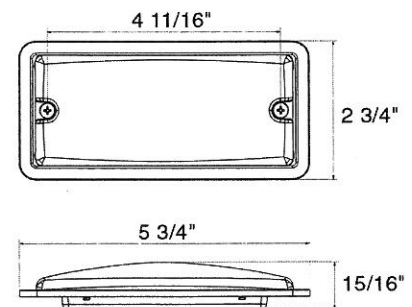

800-364-5483 / 918-683-9514
www.optronicsinc.com



Optronics®

LED TRUCK & TRAILER LIGHTING

LPL31 SERIES Mini LED License/Utility Light

- Polished, chrome plated housing
- Surface mount on 2" centers
- Design includes both lead and ground wire
- Two units required to meet DOT requirements for license light

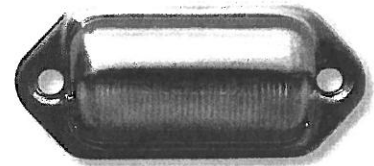

BULK P/N	POLYPACK P/N	DESCRIPTION	QTY
LICENSE LIGHT - 2 DIODES			
LPL31CB	LPL31CBP	License light	20
LPL31CEZB	LPL31CEZBP	License light, .180 molded barrels	20

FMVSS	(2) L
MATERIALS	Polycarbonate lens, chrome plated stainless steel bezel
VOLT/AMP	12.8VDC - 0.027A
WT/DIMS	.066 lb. / 2.563" x 1.188" x .938"
WARRANTY	Lifetime LED Warranty

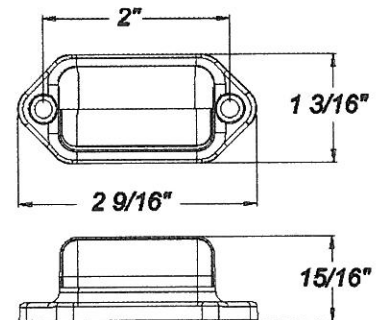

800-364-5483 / 918-683-9514
www.optronicsinc.com



ILL85 SERIES LED Exterior Step/Area Light

- Illuminate step well or pavement at base of steps or ramps
- Meets ADA lighting standard
- Surface mount, 3.662" mounting centers
- Hard wired design includes both lead and ground wires
- Operating voltage 8-30VDC, for use with 12VDC or 24VDC systems
- Polycarbonate construction with polished chrome finish
- Mounting gasket included

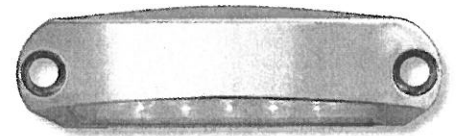
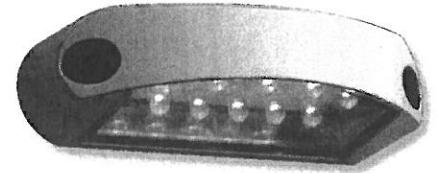

BULK P/N	POLYPACK P/N	DESCRIPTION	QTY
STEP/AREA LIGHT - 10 DIODES			
ILL85CB	ILL85CBP	Step/area light	10

MATERIALS	Polycarbonate lens and housing
VOLT/AMP	12.8VDC - .107A
WT/DIMS	.154 lb. / 4.25" x 1.24" x 1.69"
WARRANTY	Lifetime LED Warranty

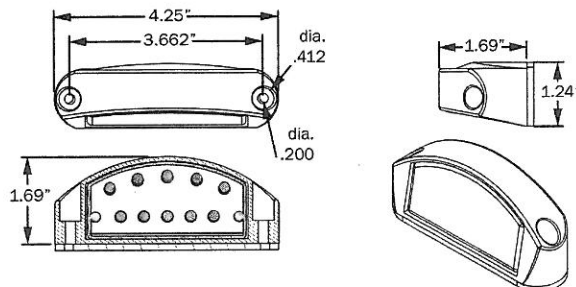

TECHNICAL QUESTIONS/ APPROVED EQUALS ON PTR13059

Appendix B

Rev.	Revision Description	By	Date	ECN / PPCN
A	DR & REL			N/A

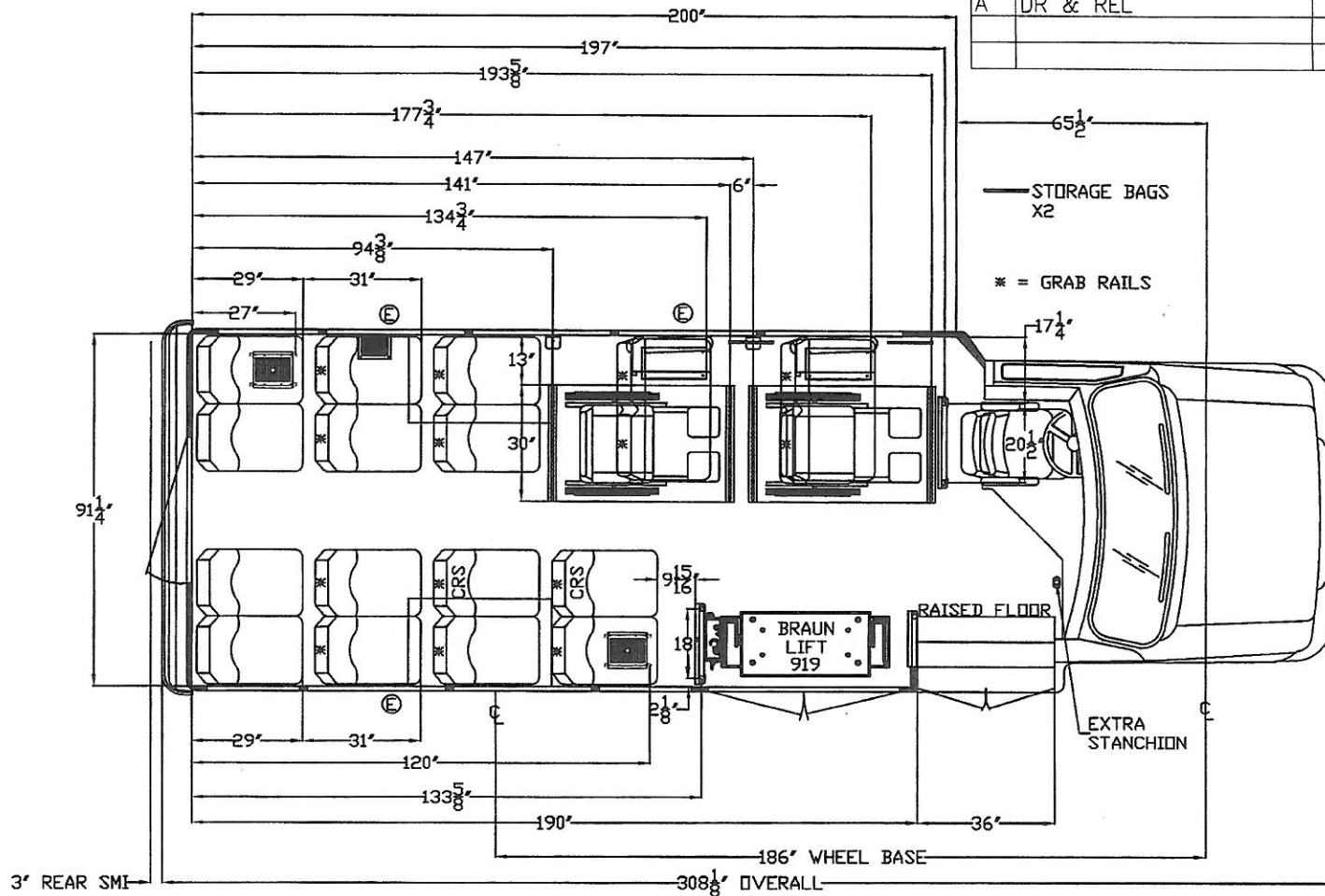

— STORAGE BAGS X2

* = GRAB RAILS

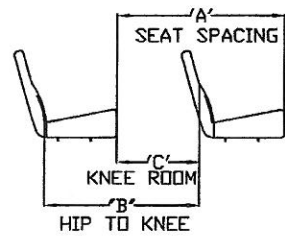

SEAT STYLE	SEAT SPACING 'A'	HIP-TO-KNEE 'B'	KNEE ROOM 'C'
MID HI	31"	27-5/8"	9-1/2"

DO NOT SCALE

Drawing Name / Description:
FLOOR PLAN, GCII 18P/2WC/186WB/308BDY

Unit Number:

Models:

Work Instruction Reference:



25161 Leer Drive
Elkhart, IN 46514
(574) 970-0063

Scale:
N/A

Units:
INCHES

Drawn:
RRP

Date:
04/09/08

Reference:

GC Part Number:

Drawing Number:
0125600

Configuration:

File location: FP/2008/GCII/186-308/F-LIFT

Revision:
A

Sheet 1 of 1

A THIS DRAWING AND THE INFORMATION CONTAINED THEREON ARE THE EXCLUSIVE PROPERTY OF GOSHEN COACH (THOR INDUSTRIES, INC.). IT SHALL NOT BE COPIED OR DUPLICATED IN ANY MANNER, NOR SHALL IT BE SUBMITTED TO OUTSIDE PARTIES FOR EXAMINATION WITHOUT OUR WRITTEN CONSENT. IT IS LOANED FOR USE WITH REFERENCE TO WORK UNDER CONTRACT WITH, OR PROPOSALS SUBMITTED TO GOSHEN COACH.

Tolerances:
+/- 1/16"
+/- 1*
Unless Noted Otherwise



Thor Industries Commercial Bus Division

ESTIMATED

F/P NO:	REF NO:	UNIT NO:
0125600	30113	10198
UNIT SERIES NO's:		DATE:
		4/30/12

WEIGHT ANALYSIS WORKSHEET

VEHICLE DESCRIPTION:				MODEL NO:	MODEL YR:	# SEATING POSITIONS
GCII 308" FORD -- 18P/2WC				GCF308-E486	2012	19 (INC. DRIVER SEAT)
CHASSIS DESCRIPTION:		ENGINE:	WHEELBASE:	TIRE SIZE:	FUEL TANK:	FUEL LEVEL:
Ford E450 186"WB, 6.8L Gas, 14,500 GVWR		6.8L (425CID) EFI V10	186	LT225/75R16E	55 Gal. Rear Tank @ 206"	1/8

VEHICLE LOAD DISTRIBUTION

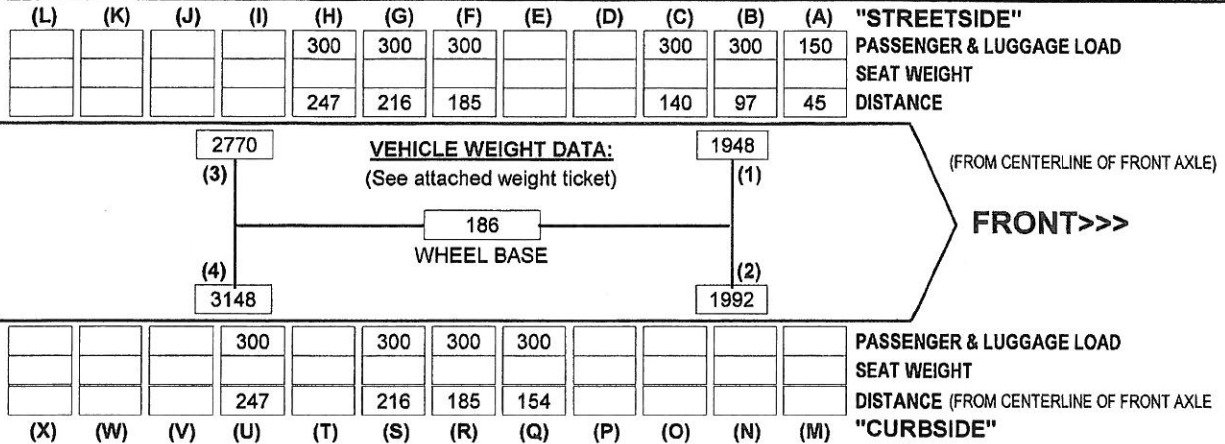

VEHICLE WEIGHT DATA:	FRONT WEIGHTS			REAR WEIGHTS			TOTAL	NOTES:
	LEFT	RIGHT	TOTAL	LEFT	RIGHT	TOTAL		
Actual Completed Weight Of Vehicle	1948	1992	3940	2770	3148	5918	9858	
FUEL LOAD ADJUSTMENT:	-16	-16	-32	163	163	327	295	
VEHICLE CONFIGURATION ADJUSTMENTS:	-15	1	-14	58	73	131	117	
UNLOADED VEHICLE WEIGHT:	1917	1977	3894	2991	3385	6376	10270	
WEIGHT OF THE OCCUPANTS & LUGGAGE:	186	-94	93	1464	1294	2757	2850	
LOADED VEHICLE WEIGHT:	2103	1883	3987	4455	4678	9133	13120	
AVAILABLE EXCESS CARGO CAPACITY:	577	797	1013	485	262	467	1380	
GROSS VEHICLE WEIGHT RATINGS:	2680	2680	5000	4940	4940	9600	14500	
IS THE WEIGHT RATING EXCEEDED?	NO	NO	NO	NO	NO	NO	NO	

PREPARED BY: Andy Snell

SIGNATURE: *Andy Snell*

DATE: 4/30/12

TECHNICAL QUESTIONS/ APPROVED EQUALS ON PTR13059

Appendix C

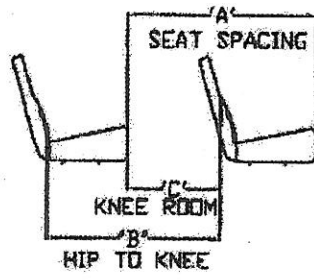
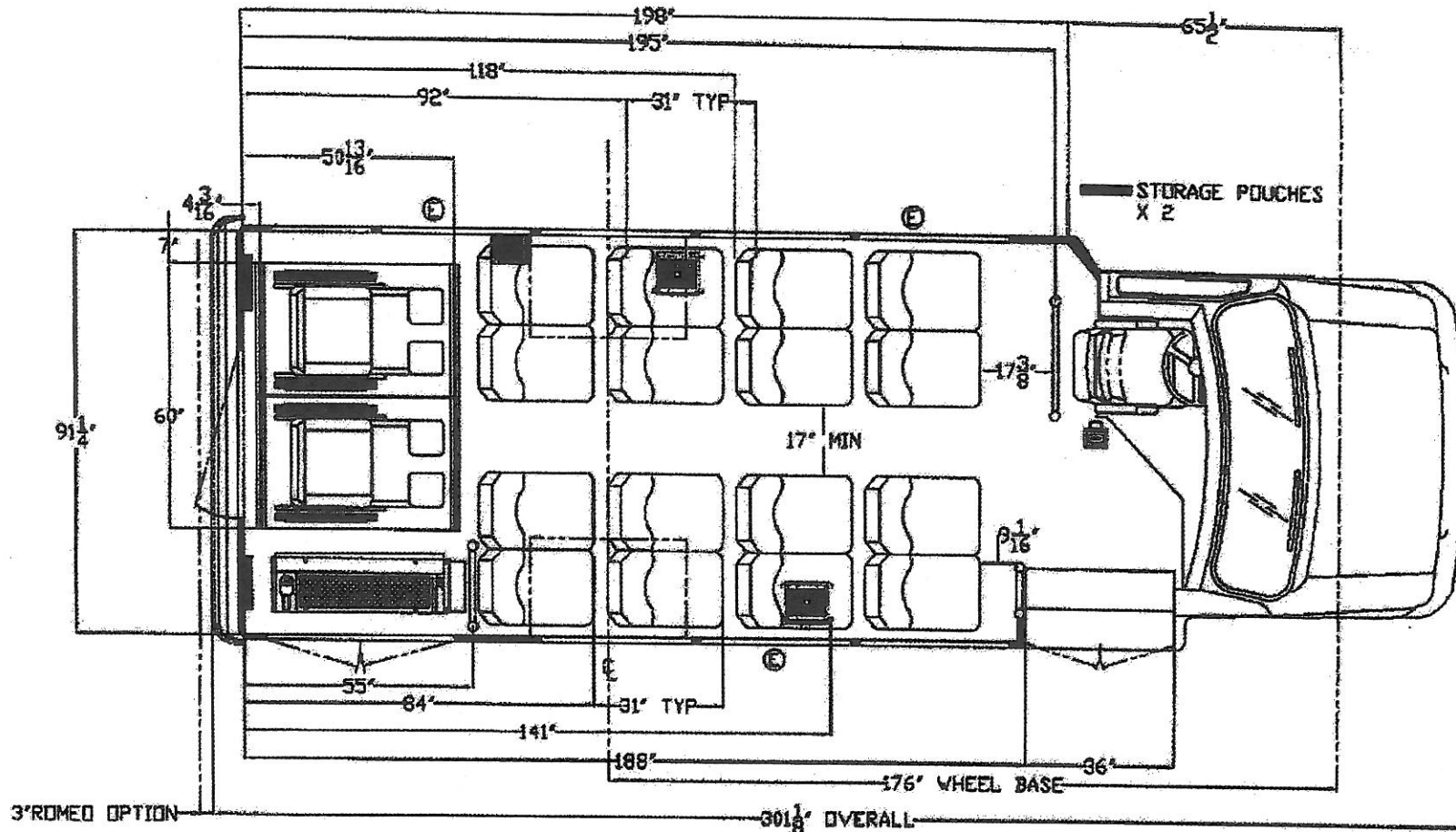

SEAT STYLE	SEAT SPACING 'A'	HIP-TO-KNEE 'B'	KNEE ROOM 'C'
MID HIGH	31"	27"	8 3/4"

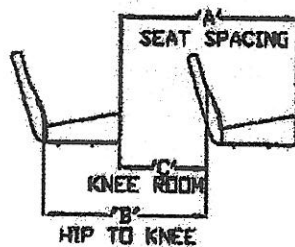
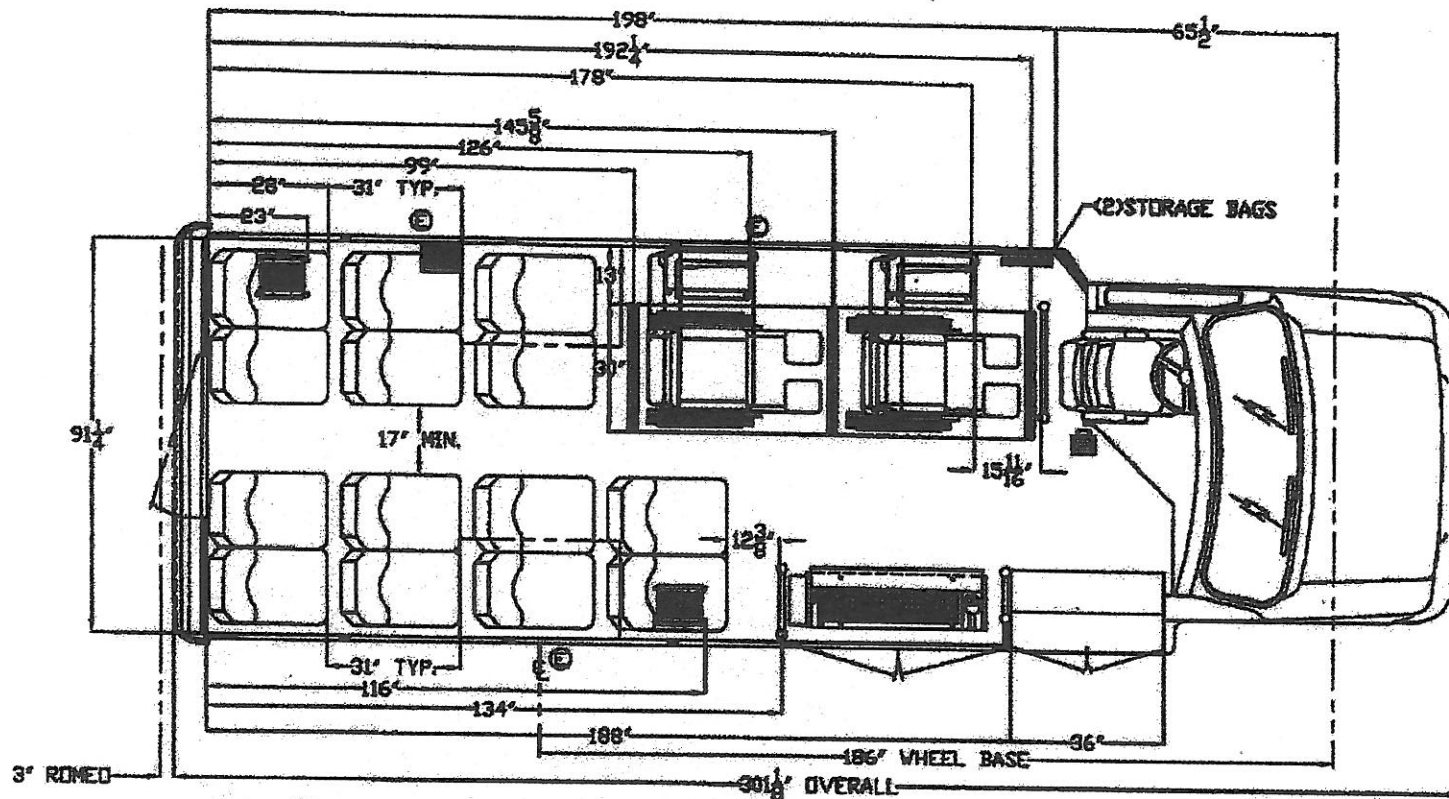

SEAT STYLE	SEAT SPACING 'A'	HIP-TO-KNEE 'B'	KNEE ROOM 'C'
MED HIGH CRIGED	31"	27"	8 3/4"

TECHNICAL QUESTIONS/ APPROVED EQUALS ON PTR13059

Appendix D

REQUEST FOR QUOTATION PTR13059
176-186" Wheelbase Transit Vehicles

REQUIRED BID FORMS

The following certifications must be properly **completed and furnished by the bidder as part of the bid**. Failure to submit any of these certifications **shall** deem the bid **non-responsive**.

A required documentation checklist has been provided for bidder's usage.

REQUEST FOR QUOTATION PTR13059
176-186" Wheelbase Transit Vehicles

**BID FORM #1: LOCATION(S) OF THE TECHNICAL SERVICE REPRESENTATIVE(S)
MANDATORY BID FORM-MUST BE SUBMITTED WITH BID**

Location(s) of the Technical Service Representative(s) and parts distribution center(s) closest to the State of West Virginia.

Name: _____

Name: _____

Address: _____

Address: _____

Telephone: _____

Telephone: _____

Name: _____

Name: _____

Address: _____

Address: _____

Telephone: _____

Telephone: _____

REQUEST FOR QUOTATION PTR13059
176-186" Wheelbase Transit Vehicles

**BID FORM #2: CERTIFICATION FOR AIR POLLUTION
MANDATORY BID FORM-MUST BE SUBMITTED WITH BID**

Pursuant to Section 8.4 of Part 1 of the Procurement, the Vendor certifies that the vehicles proposed:

____ARE or

____ARE NOT (specify one)

in compliance with the regulations in 40 CFR Part 85, 40 CFR Part 86, 40 CFR Part 600 and the air pollution criteria established by the Environmental Protection Agency of the United States Government.

Date

Authorized Signature

Title

Company Name

REQUEST FOR QUOTATION PTR13059
176-186" Wheelbase Transit Vehicles

**BID FORM #3: DISADVANTAGED BUSINESS ENTERPRISE VENDORS/ MANUFACTURERS
CERTIFICATION-- MANDATORY BID FORM-- MUST BE SUBMITTED WITH BID**

(Check appropriate statement)

_____ The Vendor, if a transit vehicle manufacturer, hereby certifies that it has complied with the requirements of 49 CFR Section 26.49 by submitting an annual DBE goal to the Federal Transit Administration (FTA). The goal has either been approved or not disapproved by FTA.

_____ The Vendor, if a non-manufacturing supplier, hereby certifies that the manufacturer of the transit vehicle to be supplied has complied with the above-referenced requirement of 49 CFR Section 26.49.

Date

Authorized Signature

Title

Company Name

REQUEST FOR QUOTATION PTR13059
176-186" Wheelbase Transit Vehicles

**BID FORM #4: BUY AMERICA CERTIFICATION ROLLING STOCK
MANDATORY BID FORM-MUST BE SUBMITTED WITH BID**

Certificate of Compliance

The bidder or offeror hereby certifies that it will comply with the requirements of section 165(b)(3), of the Surface Transportation Assistance Act of 1982, as amended, and the applicable regulations of 49 CFR 661.11:

Date

Authorized Signature

Company Name

Name

Title

Certificate for Non-Compliance

The bidder or offeror hereby certifies that it cannot comply with the requirements of section 165(b)(3) of the Surface Transportation Assistance Act of 1982, as amended, but may qualify for an exception to the requirement consistent with section 165(b)(2) or (b)(4) of the Surface Transportation Assistance Act, as amended, and the applicable regulations in 49 CFR 661.7.

Date

Authorized Signature

Company Name

Name

Title

REQUEST FOR QUOTATION PTR13059
176-186" Wheelbase Transit Vehicles

**BID FORM #5: FEDERAL MOTOR VEHICLE SAFETY STANDARDS CERTIFICATION
MANDATORY BID FORM-MUST BE SUBMITTED WITH BID**

The vendor hereby certifies that it shall submit, as required by Title 49 of the CFR, Part 663 - Subpart D, it's self certification information stating that the vehicle(s) will comply with the relevant Federal Motor Vehicle Safety Standards issued by the National Highway Traffic Safety Administration in Title 49 of the Code of Federal Regulations, Part 571.

Date

Authorized Signature

Title

Company Name

REQUEST FOR QUOTATION PTR13059
176-186" Wheelbase Transit Vehicles

**BID FORM #6—U.S. COMPTROLLER'S DEBARMENT LIST CERTIFICATION
MANDATORY BID FORM-MUST BE SUBMITTED WITH BID**

_____ hereby certifies that it

_____ IS or

_____ IS NOT (specify one)

included on the U.S. Comptroller General's Consolidated List of Persons or Firms Currently Debarred for Violations of Various Public Contracts Incorporating Labor Standards Provisions.

Date

Authorized Signature

Title

Company Name

**REQUEST FOR QUOTATION PTR13059
176-186" Wheelbase Transit Vehicles**

**BID FORM #6-A: CERTIFICATION OF PRIMARY PARTICIPANT REGARDING
DEBARMENT, SUSPENSION, AND OTHER RESPONSIBILITY MATTERS
MANDATORY BID FORM-MUST BE SUBMITTED WITH BID**

The Primary Participant (applicant for an FTA grant or cooperative agreement, or potential contractor for a major third party contract), _____
(COMPANY NAME) certifies to the best of its knowledge and belief, that it and its principals:

1. Are not presently debarred, suspended, proposed for debarment, declared ineligible, or voluntarily excluded from covered transactions by any Federal department or agency;
2. Have not within a three-year period preceding this proposal been convicted of or had a civil judgment rendered against them for commission of fraud or a criminal offense in connection with obtaining, attempting to obtain, or performing a public (Federal, State or local) transaction or contract under a public transaction; violation of Federal or State antitrust statutes or commission of embezzlement, theft, forgery, bribery, falsification or destruction of records, making false statements, or receiving stolen property;
3. Are not presently indicted for or otherwise criminally or civilly charged by a governmental entity (Federal, State or local) with commission of any of the offenses enumerated in paragraph (2) of this certification; and
4. Have not within a three-year period preceding this application/proposal had one or more public transactions (Federal, State or local) terminated for cause or default.
5. If the primary participant (applicant for an FTA grant, or cooperative agreement, or potential third party contractor) is unable to certify to any of the statements in this certification, the participant shall attach an explanation to this certification.)

THE PRIMARY PARTICIPANT (APPLICANT FOR AN FTA GRANT OR COOPERATIVE AGREEMENT, OR POTENTIAL CONTRACTOR FOR A MAJOR THIRD PARTY CONTRACT), _____, CERTIFIES OR AFFIRMS THE TRUTHFULNESS AND ACCURACY OF THE CONTENTS OF THE STATEMENTS SUBMITTED ON OR WITH THIS CERTIFICATION AND UNDERSTANDS THAT THE PROVISIONS OF 31 U.S.C. SECTIONS 3801 ET SEQ. ARE APPLICABLE THERETO.

Signature and Title of Authorized Official

REQUEST FOR QUOTATION PTR13059
176-186" Wheelbase Transit Vehicles

**BID FORM #7: VENDOR'S CERTIFICATION OF
UNDERSTANDING AND ACCEPTANCE
MANDATORY BID FORM-MUST BE SUBMITTED WITH BID**

The Vendor hereby certifies that all Technical Specifications and Contract Terms and Conditions have been carefully reviewed, are fully understood and shall be adhered to in performance and completion of any contract resulting from this bid.

Date

Authorized Signature

Title

Company Name

SPECIFICATION COMPLIANCE

NOTE: Please check if what is offered is in exact compliance with specifications. Any discrepancies must be listed as an attachment to the bid proposal. Exact dimensions and/or descriptions must be provided as a part of the Vendor's bid proposal when submitted.

_____ Bid proposal submitted meets and/or exceeds all specification requirements.

_____ Bid proposal submitted contains deviations from specification requirements. Detailed descriptions of these deviations have been provided with this bid proposal.

REQUEST FOR QUOTATION **PTR13059**
176-186" Wheelbase Transit Vehicles

**BID FORM #8: CERTIFICATION OF COMPLIANCE
WITH FTA'S BUS TESTING REQUIREMENTS
MANDATORY BID FORM-MUST BE SUBMITTED WITH BID**

The undersigned (Vendor/Manufacturer) certifies that the vehicle offered in this procurement complies with 49 U.S.C. 5318, as amended by MAP-21, and FTA regulations, "Bus Testing," 49 CFR Part 665.

The undersigned understands that misrepresenting the testing status of a vehicle acquired with Federal financial assistance may subject the undersigned to civil penalties as outlined in the Department of Transportation's regulation on Program Fraud Civil Remedies, 49 CFR Part 31. In addition, the undersigned understands that FTA may suspend or debar a manufacturer under the procedures in 2 CFR Part 1200.

Date

Authorized Signature

Title

Company Name

REQUEST FOR QUOTATION PTR13059
176-186" Wheelbase Transit Vehicles

**BID FORM #9: CERTIFICATION OF RESTRICTIONS ON LOBBYING
MANDATORY BID FORM-MUST BE SUBMITTED WITH BID**

The undersigned (Vendor, Contractor) certifies, to the best of his or her knowledge and belief, that:

- a. No Federal appropriated funds have been paid or will be paid by or on behalf of the undersigned, to any person for influence or attempt to influence an officer or employee of any Federal agency, a Member of Congress, an officer or employee of Congress, or an employee of a Member of Congress regarding the award of a Federal grant, loan (including a line of credit), cooperative agreement, loan guarantee, or loan insurance, or the extension, continuation, renewal, amendment, or modification of any Federal grant, loan (including a line of credit), cooperative agreement, loan guarantee, or loan insurance.
- b. If any funds other than Federal appropriated funds have been or will be paid to any person to influence or attempt to influence an officer or employee of any Federal agency, a Member of Congress, an officer or employee of Congress, or any employee of a Member of Congress in connection with any application for a Federal grant, loan (including a line of credit), cooperative agreement, loan guarantee, or loan insurance, the undersigned assures that it will complete and submit Standard Form-LLL, "Disclosure of Lobbying Activities," Rev. 7-97; and
- c. The undersigned understands that the language of this certification shall be included in the award documents for all subawards at all tiers (including subcontracts, sub grants, sub agreements, and contracts under grants, loans (including a line of credit), cooperative agreements, loan guarantees, and loan insurance.

Undersigned understands that this certification is a material representation of fact upon which reliance is placed by the Federal government and that submission of this certification is a prerequisite for providing a Federal grant, loan (including a line of credit), cooperative agreement, loan guarantee, or loan insurance for a transaction covered by 31 U.S.C. 1352. The undersigned also understands that any person who fails to file a required certification shall be subject to a civil penalty of not less than \$10,000 and not more than \$100,000 for each such failure.

The (Vendor, Contractor) _____, certifies or affirms the truthfulness and accuracy of each statement of its certification and disclosure, if any. In addition, the (Vendor, Contractor) understands and agrees that the provisions of 31 U.S.C. §§ 3801, et seq., apply to this certification and disclosure.

Date

Authorized Signature

Title

REQUEST FOR QUOTATION PTR13059
176-186" Wheelbase Transit Vehicles

REQUIRED BID DOCUMENTATION CHECKLIST

Model Year: _____ Model: _____

Manufacturer: _____

Mandatory Bid Forms-must be submitted with bid

- _____ Bid form 1 LOCATION(S) OF THE TECHNICAL SERVICE REPRESENTATIVE(S)
- _____ Bid form 2 CERTIFICATION FOR AIR POLLUTION
- _____ Bid form 3 DISADVANTAGED BUSINESS ENTERPRISE VENDORS/ MANUFACTURERS CERTIFICATION
- _____ Bid form 4 BUY AMERICA CERTIFICATION ROLLING STOCK
- _____ Bid form 5 FEDERAL MOTOR VEHICLE SAFETY STANDARDS CERTIFICATION
- _____ Bid form 6 U.S. COMPTROLLER'S DEBARMENT LIST CERTIFICATION
- _____ Bid form 6A CERTIFICATION OF PRIMARY PARTICIPANT REGARDING DEBARMENT, SUSPENSION, AND OTHER RESPONSIBILITY MATTERS
- _____ Bid form 7 VENDOR'S CERTIFICATION OF UNDERSTANDING AND ACCEPTANCE
- _____ Bid form 8 CERTIFICATION OF COMPLIANCE WITH FTA'S BUS TESTING REQUIREMENTS
- _____ COPY OF RELEVANT BUS TESTING REPORT- 3.5 STURAA TEST- 4 Years;
3.13.1g Water Testing- details of process; 3.15 Seating Diagram- provide proposed seating diagrams
- _____ Bid form 9 CERTIFICATION OF RESTRICTIONS ON LOBBYING
- _____ Pricing page

Mandatory Documentation-must be submitted within 48 hours of request

Section Referenced

- _____ 3.6 Engine: V-10 heavy duty gasoline engine- provide description, warranty, and literature
- _____ 3.6g High Idle System- provide description, warranty, and literature
- _____ 3.6h Engine oil cooler - provide description, warranty, and Literature
- _____ 3.7 Transmission- provide description, warranty, and literature
- _____ 3.7.d Transmission Cooling System- provide description, warranty, and literature

**REQUEST FOR QUOTATION PTR13059
176-186" Wheelbase Transit Vehicles**

- ____ 3.8.1 Heavy Duty Brakes- provide description, warranty, and literature
- ____ 3.8.3 Suspension System- provide description, warranty, and literature
- ____ 3.8.4a Tire Information- provide description, warranty, and literature
- ____ 3.9 Electrical System- provide description, warranty, and literature
- ____ 3.9.1 Alternator- specify the rectifier, method of installation, provide warranty and literature
- ____ 3.9.2 Batteries- specify type and capacity
- ____ 3.9.3 d,e,k Exterior Lights -LED Lights- provide description, warranty, and literature
- ____ 3.9.3 Exterior lighting products- provide description, warranty, and literature
- ____ 3.9.4a Interior Lights- provide description/details
- ____ 3.9.6a Rear Alarm- provide description, warranty, and literature
- ____ 3.9.6c Backup camera- provide description, warranty, and literature
- ____ 3.9.7 Fuse box panel- provide description/details
- ____ 3.10.1a Heating System- provide description, warranty and literature
- ____ 3.10.1b Stepwell Heater- provide description, warranty and literature
- ____ 3.10.1c Auxiliary Heaters- provide description, warranty and literature
- ____ 3.10.2 A/C Cooling System- provide description, warranty and literature
- ____ 3.10.2b A/C Compressor- provide description, warranty and literature
- ____ 3.10.2c A/C Condenser Information- provide description, warranty and Literature
- ____ 3.10.2e Driver's Evaporator- provide description, warranty and literature
- ____ 3.10.2e A/C Hose System- provide description, warranty and literature
- ____ 3.11 Roof Hatch- provide description, warranty and literature
- ____ 3.12.1 Control Panel Location- submit details
- ____ 3.12.1 Circulation Fan- provide description, warranty and literature
- ____ 3.13.1 Body Construction- provide description of body construction including materials, methods of joining and assembling components or subassemblies and method of attachment of the body to the chassis, warranty and literature
- ____ 3.13.2b Provide proof that skirt panel seams below floorline will be placed

**REQUEST FOR QUOTATION PTR13059
176-186" Wheelbase Transit Vehicles**

- only above wheel wells or adjacent to A/C skirt condenser
- ____ 3.13.4e Door Operating Mechanism- provide description/ details
- ____ 3.13.5a Sample of Flooring- provide colors per specifications, warranty and literature
- ____ 3.13.5e Sample of Contrast Flooring- provide color per specifications, warranty and literature
- ____ 3.13.6 Insulation- provide proof of insulation requirement per spec.
- ____ 3.13.7a Bumpers- provide description, warranty and literature
- ____ 3.14 Lift- provide details, model #, warranty and literature. Provide information and literature that lift will meet the NHTSA platform lift requirements.
- ____ 3.14g Interlock System- provide description, warranty and literature
- ____ 3.15a Passenger Seats- provide a detailed description, warranty and literature for all proposed seating, including flip up seats, child restraint seat- and ABS Knee Saver backs
- ____ 3.15b Under Seat Retractor System- provide description, warranty, literature and FMVSS 210 Report Certification
- ____ 3.15e Child Restraint Seat (ICS)
- ____ 3.15i Driver's Seat- provide description, warranty and literature
- ____ 3.16 Mobility Aid Securement- provide details of proposed system, warranty, and literature
- ____ 3.20a Exterior Mirrors- provide description, warranty and literature
- ____ 3.21 Radio/CD Stereo- provide description, provide warranty and literature
- ____ 3.24 Undercoating/Rust proofing- provide description, warranty, literature and application process
- ____ 3.25 Interior and Exterior Color Schemes- provide details of schemes available
- ____ 3.25e Paint Scheme- provide sample of vinyl chart to be used
- ____ 3.27 Strobe Light- provide description, warranty, and literature; Fixed Route Package- provide description, warranty and literature; PA System- provide description, warranty and literature; Passenger Signaling System- provide description, warranty and literature
- ____ 4.2 Extended body-- floor plan
- ____ 4.3.2 VISTA type lift- provide description, warranty and literature
- ____ 4.3.3 Passenger armrests- provide description, warranty and literature
- ____ 4.5 Floor plan

**REQUEST FOR QUOTATION PTR13059
176-186" Wheelbase Transit Vehicles**

- ____ 4.7.4 Luggage Racks-- provide description, warranty and literature
- ____ 5.2 Items in sections a-l provide proof of compliance
- ____ 6.1 Warranty on completed vehicle
- ____ 6.2 Warranty on Basic Vehicle Structure
- ____ 6.3 & 7.40f Warranty Locations- A description of how and by whom warranty service will be provided in four (4) areas of WV to cover both Mechanical and body work. Provide vendor who will do warranty of both chassis and body, including bus body, air conditioning and wheelchair lifts. Four areas of WV include: Northern Panhandle, Eastern Panhandle Central WV and Southern WV
- ____ 6.4 Warranty per specs on subsystems and components
- ____ 7.1 Complete (2) bids in binder form – (1) Marked for WVDPT
- ____ 7.36 Training- submit letter of understanding to the terms in this section
- ____ 7.40a Complete Mechanical Description of Vehicle, its construction and equipment including manufacturer's model, model name and/or number and model year Include Warranty Information
- ____ 7.40b Proposed Floorplans
- ____ 7.40c Curb Weight (empty weight and Gross Vehicle Weight Rating (GVWR) of vehicle
- ____ 7.40f Location of nearest depot which will furnish a complete supply of parts and components for the repair and maintenance of the vehicle to be supplied
- ____ 7.40g Description of the undercoating/rust proofing system, including warranty to be provided.
- ____ 7.40h Location of assembly
- ____ 7.40i List of five users names, addresses and telephone numbers to whom who have been provided similar equipment
- ____ No Debt Affidavit
- ____ Pricing page

REQUEST FOR QUOTATION
PTR13059 176-186” Wheelbase Transit Vehicles

Class	Item Description	Unit Price	Estimated	Extended Price
		Per Vehicle	Quantity	
A	Bus		5	
B	Bus, child restraint seat, security camera, rear exit		5	
C	Bus, child restraint seat, security camera, rear exit, extended body, front lift, passenger armrests		5	
D	Bus, child restraint seats, security cameras, a rear exit, extended body with front lift, 3/4 bus paint with expanded graphics		5	
E	Bus, child restraint seats, security cameras, a rear exit, extended body with front lift, a VISTA type lift or equal, passenger armrests		5	
F	Bus, extended body with front lift, passenger armrests, Full Bus Body Paint, Bike Rack Mounting Preparation		5	
G	Bus, passenger armrests, extended body, front lift , full bus paint, bike rack mounting prep, two additional seats		5	
H	Bus, extended body, armrests, full bus paint, bike rack mounting prep, overhead luggage, high back seats		5	
Total for Bid Evaluation:				

ADDENDUM ACKNOWLEDGEMENT FORM
SOLICITATION NO.: PTR13059

Instructions: Please acknowledge receipt of all addenda issued with this solicitation by completing this addendum acknowledgment form. Check the box next to each addendum received and sign below. Failure to acknowledge addenda may result in bid disqualification.

Acknowledgment: I hereby acknowledge receipt of the following addenda and have made the necessary revisions to my proposal, plans and/or specification, etc.

Addendum Numbers Received:

(Check the box next to each addendum received)

- | | |
|---|--|
| <input type="checkbox"/> Addendum No. 1 | <input type="checkbox"/> Addendum No. 6 |
| <input type="checkbox"/> Addendum No. 2 | <input type="checkbox"/> Addendum No. 7 |
| <input type="checkbox"/> Addendum No. 3 | <input type="checkbox"/> Addendum No. 8 |
| <input type="checkbox"/> Addendum No. 4 | <input type="checkbox"/> Addendum No. 9 |
| <input type="checkbox"/> Addendum No. 5 | <input type="checkbox"/> Addendum No. 10 |

I understand that failure to confirm the receipt of addenda may be cause for rejection of this bid. I further understand that any verbal representation made or assumed to be made during any oral discussion held between Vendor's representatives and any state personnel is not binding. Only the information issued in writing and added to the specifications by an official addendum is binding.

Company

Authorized Signature

Date

NOTE: This addendum acknowledgment should be submitted with the bid to expedite document processing.
 Revised 6/8/2012