



State of West Virginia
 Department of Administration
 Purchasing Division
 2019 Washington Street East
 Post Office Box 50130
 Charleston, WV 25305-0130

Solicitation

NUMBER
08140024

PAGE
1

ADDRESS CORRESPONDENCE TO ATTENTION OF:
ALAN CUMMINGS 304-558-2402

RFQ COPY

TYPE NAME/ADDRESS HERE

V
E
N
D
O
R

S
H
I
P
T
O

DIVISION OF HIGHWAYS
 JOBSITE
 SEE SPECIFICATIONS

DATE PRINTED
09/10/2013

BID OPENING DATE: 10/02/2013

BID OPENING TIME 1:30PM

LINE	QUANTITY	UOP	CAT. NO.	ITEM NUMBER	UNIT PRICE	AMOUNT
0001	470	LS		210-16		
PRESTRESSED CONCRETE PLANK BEAMS & ACCESSORIES						
REQUEST FOR QUOTATION (ONE-TIME PURCHASE)						
THE WEST VIRGINIA STATE PURCHASING DIVISION FOR THE AGENCY, THE WEST VIRGINIA DIVISION OF HIGHWAYS, IS SOLICITING BIDS TO PROVIDE THE AGENCY WITH THE ONE-TIME PURCHASE OF PRESTRESSED CONCRETE PLANK BEAMS WITH ACCESSORIES PER THE ATTACHED SPECIFICATIONS.						
***** THIS IS THE END OF RFQ 08140024 ***** TOTAL:						

SIGNATURE		TELEPHONE		DATE
TITLE	FEIN	ADDRESS CHANGES TO BE NOTED ABOVE		

WHEN RESPONDING TO SOLICITATION, INSERT NAME AND ADDRESS IN SPACE ABOVE LABELED 'VENDOR'

INSTRUCTIONS TO VENDORS SUBMITTING BIDS

1. **REVIEW DOCUMENTS THOROUGHLY:** The attached documents contain a solicitation for bids. Please read these instructions and all documents attached in their entirety. These instructions provide critical information about requirements that if overlooked could lead to disqualification of a Vendor's bid. All bids must be submitted in accordance with the provisions contained in these instructions and the Solicitation. Failure to do so may result in disqualification of Vendor's bid.
2. **MANDATORY TERMS:** The Solicitation may contain mandatory provisions identified by the use of the words "must," "will," and "shall." Failure to comply with a mandatory term in the Solicitation will result in bid disqualification.

3. **PREBID MEETING:** The item identified below shall apply to this Solicitation.

A pre-bid meeting will not be held prior to bid opening.

A **NON-MANDATORY PRE-BID** meeting will be held at the following place and time:

A **MANDATORY PRE-BID** meeting will be held at the following place and time:

All Vendors submitting a bid must attend the mandatory pre-bid meeting. Failure to attend the mandatory pre-bid meeting shall result in disqualification of the Vendor's bid. No one person attending the pre-bid meeting may represent more than one Vendor.

An attendance sheet provided at the pre-bid meeting shall serve as the official document verifying attendance. The State will not accept any other form of proof or documentation to verify attendance. Any person attending the pre-bid meeting on behalf of a Vendor must list on the attendance sheet his or her name and the name of the Vendor he or she is representing. Additionally, the person attending the pre-bid meeting should include the Vendor's E-Mail address, phone number, and Fax number on the attendance sheet. It is the Vendor's responsibility to locate the attendance sheet and provide the required

information. Failure to complete the attendance sheet as required may result in disqualification of Vendor's bid.

All Vendors should arrive prior to the starting time for the pre-bid. Vendors who arrive after the starting time but prior to the end of the pre-bid will be permitted to sign in, but are charged with knowing all matters discussed at the pre-bid.

Questions submitted at least five business days prior to a scheduled pre-bid will be discussed at the pre-bid meeting if possible. Any discussions or answers to questions at the pre-bid meeting are preliminary in nature and are non-binding. Official and binding answers to questions will be published in a written addendum to the Solicitation prior to bid opening.

4. **VENDOR QUESTION DEADLINE:** Vendors may submit questions relating to this Solicitation to the Purchasing Division. Questions must be submitted in writing. All questions must be submitted on or before the date listed below and to the address listed below in order to be considered. A written response will be published in a Solicitation addendum if a response is possible and appropriate. Non-written discussions, conversations, or questions and answers regarding this Solicitation are preliminary in nature and are non-binding.

Question Submission Deadline: 09/25/2013

Submit Questions to: Alan Cummings
 2019 Washington Street, East
 Charleston, WV 25305
 Fax: 304-558-3970
 Email: Alan.W.Cummings@WV.Gov

5. **VERBAL COMMUNICATION:** Any verbal communication between the Vendor and any State personnel is not binding, including that made at the mandatory pre-bid conference. Only information issued in writing and added to the Solicitation by an official written addendum by the Purchasing Division is binding.
6. **BID SUBMISSION:** All bids must be signed and delivered by the Vendor to the Purchasing Division at the address listed below on or before the date and time of the bid opening. Any bid received by the Purchasing Division staff is considered to be in the possession of the Purchasing Division and will not be returned for any reason. The bid delivery address is:

Department of Administration, Purchasing Division
 2019 Washington Street East
 Charleston, WV 25305-0130

The bid should contain the information listed below on the face of the envelope or the bid may not be considered:

SEALED BID

BUYER: _____

SOLICITATION NO.: _____

BID OPENING DATE: _____

BID OPENING TIME: _____

FAX NUMBER: _____

In the event that Vendor is responding to a request for proposal, the Vendor shall submit one original technical and one original cost proposal plus n/a convenience copies of each to the Purchasing Division at the address shown above. Additionally, the Vendor should identify the bid type as either a technical or cost proposal on the face of each bid envelope submitted in response to a request for proposal as follows:

BID TYPE: Technical
 Cost

7. **BID OPENING:** Bids submitted in response to this Solicitation will be opened at the location identified below on the date and time listed below. Delivery of a bid after the bid opening date and time will result in bid disqualification. For purposes of this Solicitation, a bid is considered delivered when time stamped by the official Purchasing Division time clock.

Bid Opening Date and Time: 10/02/2013 - 1:30 P.M.

Bid Opening Location: Department of Administration, Purchasing Division
 2019 Washington Street East
 Charleston, WV 25305-0130

8. **ADDENDUM ACKNOWLEDGEMENT:** Changes or revisions to this Solicitation will be made by an official written addendum issued by the Purchasing Division. Vendor should acknowledge receipt of all addenda issued with this Solicitation by completing an Addendum Acknowledgment Form, a copy of which is included herewith. Failure to acknowledge addenda may result in bid disqualification. The addendum acknowledgement should be submitted with the bid to expedite document processing.
9. **BID FORMATTING:** Vendor should type or electronically enter the information onto its bid to prevent errors in the evaluation. Failure to type or electronically enter the information may result in bid disqualification.

GENERAL TERMS AND CONDITIONS:

1. **CONTRACTUAL AGREEMENT:** Issuance of a Purchase Order signed by the Purchasing Division Director, or his designee, and approved as to form by the Attorney General's office constitutes acceptance of this Contract made by and between the State of West Virginia and the Vendor. Vendor's signature on its bid signifies Vendor's agreement to be bound by and accept the terms and conditions contained in this Contract.

2. **DEFINITIONS:** As used in this Solicitation / Contract, the following terms shall have the meanings attributed to them below. Additional definitions may be found in the specifications included with this Solicitation / Contract.
 - 2.1 **"Agency" or "Agencies"** means the agency, board, commission, or other entity of the State of West Virginia that is identified on the first page of the Solicitation or any other public entity seeking to procure goods or services under this Contract.
 - 2.2 **"Contract"** means the binding agreement that is entered into between the State and the Vendor to provide the goods and services requested in the Solicitation.
 - 2.3 **"Director"** means the Director of the West Virginia Department of Administration, Purchasing Division.
 - 2.4 **"Purchasing Division"** means the West Virginia Department of Administration, Purchasing Division.
 - 2.5 **"Purchase Order"** means the document signed by the Agency and the Purchasing Division, and approved as to form by the Attorney General, that identifies the Vendor as the successful bidder and Contract holder.
 - 2.6 **"Solicitation"** means the official solicitation published by the Purchasing Division and identified by number on the first page thereof.
 - 2.7 **"State"** means the State of West Virginia and/or any of its agencies, commissions, boards, etc. as context requires.
 - 2.8 **"Vendor" or "Vendors"** means any entity submitting a bid in response to the Solicitation, the entity that has been selected as the lowest responsible bidder, or the entity that has been awarded the Contract as context requires.

3. **CONTRACT TERM; RENEWAL; EXTENSION:** The term of this Contract shall be determined in accordance with the category that has been identified as applicable to this Contract below:

Term Contract

Initial Contract Term: This Contract becomes effective on

and extends for a period of _____ year(s).

Renewal Term: This Contract may be renewed upon the mutual written consent of the Agency, and the Vendor, with approval of the Purchasing Division and the Attorney General's office (Attorney General approval is as to form only). Any request for renewal must be submitted to the Purchasing Division Director thirty (30) days prior to the expiration date of the initial contract term or appropriate renewal term. A Contract renewal shall be in accordance with the terms and conditions of the original contract. Renewal of this Contract is limited to _____ successive one (1) year periods. Automatic renewal of this Contract is prohibited. Notwithstanding the foregoing, Purchasing Division approval is not required on agency delegated or exempt purchases. Attorney General approval may be required for vendor terms and conditions.

Reasonable Time Extension: At the sole discretion of the Purchasing Division Director, and with approval from the Attorney General's office (Attorney General approval is as to form only), this Contract may be extended for a reasonable time after the initial Contract term or after any renewal term as may be necessary to obtain a new contract or renew this Contract. Any reasonable time extension shall not exceed twelve (12) months. Vendor may avoid a reasonable time extension by providing the Purchasing Division Director with written notice of Vendor's desire to terminate this Contract 30 days prior to the expiration of the then current term. During any reasonable time extension period, the Vendor may terminate this Contract for any reason upon giving the Purchasing Division Director 30 days written notice. Automatic extension of this Contract is prohibited. Notwithstanding the foregoing, Purchasing Division approval is not required on agency delegated or exempt purchases, but Attorney General approval may be required.

Release Order Limitations: In the event that this contract permits release orders, a release order may only be issued during the time this Contract is in effect. Any release order issued within one year of the expiration of this Contract shall be effective for one year from the date the release order is issued. No release order may be extended beyond one year after this Contract has expired.

Fixed Period Contract: This Contract becomes effective upon Vendor's receipt of the notice to proceed and must be completed within _____ days.

One Time Purchase: The term of this Contract shall run from the issuance of the Purchase Order until all of the goods contracted for have been delivered, but in no event shall this Contract extend for more than one fiscal year.

Other: See attached.

4. **NOTICE TO PROCEED:** Vendor shall begin performance of this Contract immediately upon receiving notice to proceed unless otherwise instructed by the Agency. Unless otherwise specified, the fully executed Purchase Order will be considered notice to proceed

5. **QUANTITIES:** The quantities required under this Contract shall be determined in accordance with the category that has been identified as applicable to this Contract below.

Open End Contract: Quantities listed in this Solicitation are approximations only, based on estimates supplied by the Agency. It is understood and agreed that the Contract shall cover the quantities actually ordered for delivery during the term of the Contract, whether more or less than the quantities shown.

Service: The scope of the service to be provided will be more clearly defined in the specifications included herewith.

Combined Service and Goods: The scope of the service and deliverable goods to be provided will be more clearly defined in the specifications included herewith.

One Time Purchase: This Contract is for the purchase of a set quantity of goods that are identified in the specifications included herewith. Once those items have been delivered, no additional goods may be procured under this Contract without an appropriate change order approved by the Vendor, Agency, Purchasing Division, and Attorney General's office.

6. **PRICING:** The pricing set forth herein is firm for the life of the Contract, unless specified elsewhere within this Solicitation/Contract by the State. A Vendor's inclusion of price adjustment provisions in its bid, without an express authorization from the State in the Solicitation to do so, may result in bid disqualification.

7. **EMERGENCY PURCHASES:** The Purchasing Division Director may authorize the Agency to purchase goods or services in the open market that Vendor would otherwise provide under this Contract if those goods or services are for immediate or expedited delivery in an emergency. Emergencies shall include, but are not limited to, delays in transportation or an unanticipated increase in the volume of work. An emergency purchase in the open market, approved by the Purchasing Division Director, shall not constitute of breach of this Contract and shall not entitle the Vendor to any form of compensation or damages. This provision does not excuse the State from fulfilling its obligations under a One Time Purchase contract.

8. **REQUIRED DOCUMENTS:** All of the items checked below must be provided to the Purchasing Division by the Vendor as specified below.

BID BOND: All Vendors shall furnish a bid bond in the amount of five percent (5%) of the total amount of the bid protecting the State of West Virginia. The bid bond must be submitted with the bid.

PERFORMANCE BOND: The apparent successful Vendor shall provide a performance bond in the amount of . The performance bond must be issued and received by the Purchasing Division prior to Contract award. On construction contracts, the performance bond must be 100% of the Contract value.

LABOR/MATERIAL PAYMENT BOND: The apparent successful Vendor shall provide a labor/material payment bond in the amount of 100% of the Contract value. The labor/material payment bond must be issued and delivered to the Purchasing Division prior to Contract award.

In lieu of the Bid Bond, Performance Bond, and Labor/Material Payment Bond, the Vendor may provide certified checks, cashier's checks, or irrevocable letters of credit. Any certified check, cashier's check, or irrevocable letter of credit provided in lieu of a bond must be of the same amount and delivered on the same schedule as the bond it replaces. A letter of credit submitted in lieu of a performance and labor/material payment bond will only be allowed for projects under \$100,000. Personal or business checks are not acceptable.

MAINTENANCE BOND: The apparent successful Vendor shall provide a two (2) year maintenance bond covering the roofing system. The maintenance bond must be issued and delivered to the Purchasing Division prior to Contract award.

WORKERS' COMPENSATION INSURANCE: The apparent successful Vendor shall have appropriate workers' compensation insurance and shall provide proof thereof upon request.

INSURANCE: The apparent successful Vendor shall furnish proof of the following insurance prior to Contract award and shall list the state as a certificate holder:

Commercial General Liability Insurance:
or more.

Builders Risk Insurance: builders risk – all risk insurance in an amount equal to 100% of the amount of the Contract.

The apparent successful Vendor shall also furnish proof of any additional insurance requirements contained in the specifications prior to Contract award regardless of whether or not that insurance requirement is listed above.

- LICENSE(S) / CERTIFICATIONS / PERMITS:** In addition to anything required under the Section entitled Licensing, of the General Terms and Conditions, the apparent successful Vendor shall furnish proof of the following licenses, certifications, and/or permits prior to Contract award, in a form acceptable to the Purchasing Division.

The apparent successful Vendor shall also furnish proof of any additional licenses or certifications contained in the specifications prior to Contract award regardless of whether or not that requirement is listed above.

9. **LITIGATION BOND:** The Director reserves the right to require any Vendor that files a protest of an award to submit a litigation bond in the amount equal to one percent of the lowest bid submitted or \$5,000, whichever is greater. The entire amount of the bond shall be forfeited if the hearing officer determines that the protest was filed for frivolous or improper purpose, including but not limited to, the purpose of harassing, causing unnecessary delay, or needless expense for the Agency. All litigation bonds shall be made payable to the Purchasing Division. In lieu of a bond, the protester may submit a cashier's check or certified check payable to the Purchasing Division. Cashier's or certified checks will be deposited with and held by the State Treasurer's office. If it is determined that the protest has not been filed for frivolous or improper purpose, the bond or deposit shall be returned in its entirety.
10. **ALTERNATES:** Any model, brand, or specification listed herein establishes the acceptable level of quality only and is not intended to reflect a preference for, or in any way favor, a particular brand or vendor. Vendors may bid alternates to a listed model or brand provided that the alternate is at least equal to the model or brand and complies with the required specifications. The equality of any alternate being bid shall be determined by the State at its sole discretion. Any Vendor bidding an alternate model or brand should clearly identify the alternate items in its bid and should include manufacturer's specifications, industry literature, and/or any other relevant documentation demonstrating the equality of the alternate items. Failure to provide information for alternate items may be grounds for rejection of a Vendor's bid.
11. **EXCEPTIONS AND CLARIFICATIONS:** The Solicitation contains the specifications that shall form the basis of a contractual agreement. Vendor shall clearly mark any exceptions, clarifications, or

other proposed modifications in its bid. Exceptions to, clarifications of, or modifications of a requirement or term and condition of the Solicitation may result in bid disqualification.

- 12. LIQUIDATED DAMAGES:** Vendor shall pay liquidated damages in the amount
n/a for n/a

This clause shall in no way be considered exclusive and shall not limit the State or Agency's right to pursue any other available remedy.

- 13. ACCEPTANCE/REJECTION:** The State may accept or reject any bid in whole, or in part. Vendor's signature on its bid signifies acceptance of the terms and conditions contained in the Solicitation and Vendor agrees to be bound by the terms of the Contract, as reflected in the Purchase Order, upon receipt.
- 14. REGISTRATION:** Prior to Contract award, the apparent successful Vendor must be properly registered with the West Virginia Purchasing Division and must have paid the \$125 fee if applicable.
- 15. COMMUNICATION LIMITATIONS:** In accordance with West Virginia Code of State Rules §148-1-6.6, communication with the State of West Virginia or any of its employees regarding this Solicitation during the solicitation, bid, evaluation or award periods, except through the Purchasing Division, is strictly prohibited without prior Purchasing Division approval. Purchasing Division approval for such communication is implied for all agency delegated and exempt purchases.
- 16. FUNDING:** This Contract shall continue for the term stated herein, contingent upon funds being appropriated by the Legislature or otherwise being made available. In the event funds are not appropriated or otherwise made available, this Contract becomes void and of no effect beginning on July 1 of the fiscal year for which funding has not been appropriated or otherwise made available.
- 17. PAYMENT:** Payment in advance is prohibited under this Contract. Payment may only be made after the delivery and acceptance of goods or services. The Vendor shall submit invoices, in arrears, to the Agency at the address on the face of the purchase order labeled "Invoice To."
- 18. UNIT PRICE:** Unit prices shall prevail in cases of a discrepancy in the Vendor's bid.
- 19. DELIVERY:** All quotations are considered freight on board destination ("F.O.B. destination") unless alternate shipping terms are clearly identified in the bid. Vendor's listing of shipping terms that contradict the shipping terms expressly required by this Solicitation may result in bid disqualification.
- 20. INTEREST:** Interest attributable to late payment will only be permitted if authorized by the West Virginia Code. Presently, there is no provision in the law for interest on late payments.
- 21. PREFERENCE:** Vendor Preference may only be granted upon written request and only in accordance with the West Virginia Code § 5A-3-37 and the West Virginia Code of State Rules. A Resident Vendor Certification form has been attached hereto to allow Vendor to apply for the preference. Vendor's

failure to submit the Resident Vendor Certification form with its bid will result in denial of Vendor Preference. Vendor Preference does not apply to construction projects.

22. **SMALL, WOMEN-OWNED, OR MINORITY-OWNED BUSINESSES:** For any solicitations publicly advertised for bid on or after July 1, 2012, in accordance with West Virginia Code §5A-3-37(a)(7) and W. Va. CSR § 148-22-9, any non-resident vendor certified as a small, women-owned, or minority-owned business under W. Va. CSR § 148-22-9 shall be provided the same preference made available to any resident vendor. Any non-resident small, women-owned, or minority-owned business must identify itself as such in writing, must submit that writing to the Purchasing Division with its bid, and must be properly certified under W. Va. CSR § 148-22-9 prior to submission of its bid to receive the preferences made available to resident vendors. Preference for a non-resident small, women-owned, or minority owned business shall be applied in accordance with W. Va. CSR § 148-22-9.
23. **TAXES:** The Vendor shall pay any applicable sales, use, personal property or any other taxes arising out of this Contract and the transactions contemplated thereby. The State of West Virginia is exempt from federal and state taxes and will not pay or reimburse such taxes.
24. **CANCELLATION:** The Purchasing Division Director reserves the right to cancel this Contract immediately upon written notice to the vendor if the materials or workmanship supplied do not conform to the specifications contained in the Contract. The Purchasing Division Director may cancel any purchase or Contract upon 30 days written notice to the Vendor in accordance with West Virginia Code of State Rules § 148-1-7.16.2.
25. **WAIVER OF MINOR IRREGULARITIES:** The Director reserves the right to waive minor irregularities in bids or specifications in accordance with West Virginia Code of State Rules § 148-1-4.6.
26. **TIME:** Time is of the essence with regard to all matters of time and performance in this Contract.
27. **APPLICABLE LAW:** This Contract is governed by and interpreted under West Virginia law without giving effect to its choice of law principles. Any information provided in specification manuals, or any other source, verbal or written, which contradicts or violates the West Virginia Constitution, West Virginia Code or West Virginia Code of State Rules is void and of no effect.
28. **COMPLIANCE:** Vendor shall comply with all applicable federal, state, and local laws, regulations and ordinances. By submitting a bid, Vendors acknowledge that they have reviewed, understand, and will comply with all applicable law.
29. **PREVAILING WAGE:** On any contract for the construction of a public improvement, Vendor and any subcontractors utilized by Vendor shall pay a rate or rates of wages which shall not be less than the fair minimum rate or rates of wages (prevailing wage), as established by the West Virginia Division of Labor under West Virginia Code §§ 21-5A-1 et seq. and available at <http://www.sos.wv.gov/administrative-law/wagerates/Pages/default.aspx>. Vendor shall be responsible for ensuring compliance with prevailing wage requirements and determining when prevailing wage

requirements are applicable. The required contract provisions contained in West Virginia Code of State Rules § 42-7-3 are specifically incorporated herein by reference.

- 30. ARBITRATION:** Any references made to arbitration contained in this Contract, Vendor's bid, or in any American Institute of Architects documents pertaining to this Contract are hereby deleted, void, and of no effect.
- 31. MODIFICATIONS:** This writing is the parties' final expression of intent. Notwithstanding anything contained in this Contract to the contrary, no modification of this Contract shall be binding without mutual written consent of the Agency, and the Vendor, with approval of the Purchasing Division and the Attorney General's office (Attorney General approval is as to form only). **No Change shall be implemented by the Vendor until such time as the Vendor receives an approved written change order from the Purchasing Division.**
- 32. WAIVER:** The failure of either party to insist upon a strict performance of any of the terms or provision of this Contract, or to exercise any option, right, or remedy herein contained, shall not be construed as a waiver or a relinquishment for the future of such term, provision, option, right, or remedy, but the same shall continue in full force and effect. Any waiver must be expressly stated in writing and signed by the waiving party.
- 33. SUBSEQUENT FORMS:** The terms and conditions contained in this Contract shall supersede any and all subsequent terms and conditions which may appear on any form documents submitted by Vendor to the Agency or Purchasing Division such as price lists, order forms, invoices, sales agreements, or maintenance agreements, and includes internet websites or other electronic documents. Acceptance or use of Vendor's forms does not constitute acceptance of the terms and conditions contained thereon.
- 34. ASSIGNMENT:** Neither this Contract nor any monies due, or to become due hereunder, may be assigned by the Vendor without the express written consent of the Agency, the Purchasing Division, the Attorney General's office (as to form only), and any other government agency or office that may be required to approve such assignments. Notwithstanding the foregoing, Purchasing Division approval may or may not be required on certain agency delegated or exempt purchases.
- 35. WARRANTY:** The Vendor expressly warrants that the goods and/or services covered by this Contract will: (a) conform to the specifications, drawings, samples, or other description furnished or specified by the Agency; (b) be merchantable and fit for the purpose intended; and (c) be free from defect in material and workmanship.
- 36. STATE EMPLOYEES:** State employees are not permitted to utilize this Contract for personal use and the Vendor is prohibited from permitting or facilitating the same.
- 37. BANKRUPTCY:** In the event the Vendor files for bankruptcy protection, the State of West Virginia may deem this Contract null and void, and terminate this Contract without notice.

38. [RESERVED]

- 39. CONFIDENTIALITY:** The Vendor agrees that it will not disclose to anyone, directly or indirectly, any such personally identifiable information or other confidential information gained from the Agency, unless the individual who is the subject of the information consents to the disclosure in writing or the disclosure is made pursuant to the Agency's policies, procedures, and rules. Vendor further agrees to comply with the Confidentiality Policies and Information Security Accountability Requirements, set forth in <http://www.state.wv.us/admin/purchase/privacy/default.html>.
- 40. DISCLOSURE:** Vendor's response to the Solicitation and the resulting Contract are considered public documents and will be disclosed to the public in accordance with the laws, rules, and policies governing the West Virginia Purchasing Division. Those laws include, but are not limited to, the Freedom of Information Act found in West Virginia Code § 29B-1-1 et seq.

If a Vendor considers any part of its bid to be exempt from public disclosure, Vendor must so indicate by specifically identifying the exempt information, identifying the exemption that applies, providing a detailed justification for the exemption, segregating the exempt information from the general bid information, and submitting the exempt information as part of its bid but in a segregated and clearly identifiable format. Failure to comply with the foregoing requirements will result in public disclosure of the Vendor's bid without further notice. A Vendor's act of marking all or nearly all of its bid as exempt is not sufficient to avoid disclosure and WILL NOT BE HONORED. Vendor's act of marking a bid or any part thereof as "confidential" or "proprietary" is not sufficient to avoid disclosure and WILL NOT BE HONORED. In addition, a legend or other statement indicating that all or substantially all of the bid is exempt from disclosure is not sufficient to avoid disclosure and WILL NOT BE HONORED. Vendor will be required to defend any claimed exemption for nondisclosure in the event of an administrative or judicial challenge to the State's nondisclosure. Vendor must indemnify the State for any costs incurred related to any exemptions claimed by Vendor. Any questions regarding the applicability of the various public records laws should be addressed to your own legal counsel prior to bid submission.

- 41. LICENSING:** In accordance with West Virginia Code of State Rules §148-1-6.1.7, Vendor must be licensed and in good standing in accordance with any and all state and local laws and requirements by any state or local agency of West Virginia, including, but not limited to, the West Virginia Secretary of State's Office, the West Virginia Tax Department, West Virginia Insurance Commission, or any other state agency or political subdivision. Upon request, the Vendor must provide all necessary releases to obtain information to enable the Purchasing Division Director or the Agency to verify that the Vendor is licensed and in good standing with the above entities.
- 42. ANTITRUST:** In submitting a bid to, signing a contract with, or accepting a Purchase Order from any agency of the State of West Virginia, the Vendor agrees to convey, sell, assign, or transfer to the State of West Virginia all rights, title, and interest in and to all causes of action it may now or hereafter acquire under the antitrust laws of the United States and the State of West Virginia for price fixing and/or unreasonable restraints of trade relating to the particular commodities or services purchased or acquired by the State of West Virginia. Such assignment shall be made and become effective at the time the

purchasing agency tenders the initial payment to Vendor.

- 43. VENDOR CERTIFICATIONS:** By signing its bid or entering into this Contract, Vendor certifies (1) that its bid was made without prior understanding, agreement, or connection with any corporation, firm, limited liability company, partnership, person or entity submitting a bid for the same material, supplies, equipment or services; (2) that its bid is in all respects fair and without collusion or fraud; (3) that this Contract is accepted or entered into without any prior understanding, agreement, or connection to any other entity that could be considered a violation of law; and (4) that it has reviewed this RFQ in its entirety, understands the requirements, terms and conditions, and other information contained herein. Vendor's signature on its bid also affirms that neither it nor its representatives have any interest, nor shall acquire any interest, direct or indirect, which would compromise the performance of its services hereunder. Any such interests shall be promptly presented in detail to the Agency.

The individual signing this bid on behalf of Vendor certifies that he or she is authorized by the Vendor to execute this bid or any documents related thereto on Vendor's behalf; that he or she is authorized to bind the Vendor in a contractual relationship; and that, to the best of his or her knowledge, the Vendor has properly registered with any State agency that may require registration.

- 44. PURCHASING CARD ACCEPTANCE:** The State of West Virginia currently utilizes a Purchasing Card program, administered under contract by a banking institution, to process payment for goods and services. The Vendor must accept the State of West Virginia's Purchasing Card for payment of all orders under this Contract unless the box below is checked.

Vendor is not required to accept the State of West Virginia's Purchasing Card as payment for all goods and services.

- 45. VENDOR RELATIONSHIP:** The relationship of the Vendor to the State shall be that of an independent contractor and no principal-agent relationship or employer-employee relationship is contemplated or created by this Contract. The Vendor as an independent contractor is solely liable for the acts and omissions of its employees and agents. Vendor shall be responsible for selecting, supervising, and compensating any and all individuals employed pursuant to the terms of this Solicitation and resulting contract. Neither the Vendor, nor any employees or subcontractors of the Vendor, shall be deemed to be employees of the State for any purpose whatsoever. Vendor shall be exclusively responsible for payment of employees and contractors for all wages and salaries, taxes, withholding payments, penalties, fees, fringe benefits, professional liability insurance premiums, contributions to insurance and pension, or other deferred compensation plans, including but not limited to, Workers' Compensation and Social Security obligations, licensing fees, *etc.* and the filing of all necessary documents, forms and returns pertinent to all of the foregoing. Vendor shall hold harmless the State, and shall provide the State and Agency with a defense against any and all claims including, but not limited to, the foregoing payments, withholdings, contributions, taxes, Social Security taxes, and employer income tax returns.

- 46. INDEMNIFICATION:** The Vendor agrees to indemnify, defend, and hold harmless the State and the Agency, their officers, and employees from and against: (1) Any claims or losses for services rendered

by any subcontractor, person, or firm performing or supplying services, materials, or supplies in connection with the performance of the Contract; (2) Any claims or losses resulting to any person or entity injured or damaged by the Vendor, its officers, employees, or subcontractors by the publication, translation, reproduction, delivery, performance, use, or disposition of any data used under the Contract in a manner not authorized by the Contract, or by Federal or State statutes or regulations; and (3) Any failure of the Vendor, its officers, employees, or subcontractors to observe State and Federal laws including, but not limited to, labor and wage and hour laws.

- 47. PURCHASING AFFIDAVIT:** In accordance with West Virginia Code § 5A-3-10a, all Vendors are required to sign, notarize, and submit the Purchasing Affidavit stating that neither the Vendor nor a related party owe a debt to the State in excess of \$1,000. The affidavit must be submitted prior to award, but should be submitted with the Vendor's bid. A copy of the Purchasing Affidavit is included herewith.
- 48. ADDITIONAL AGENCY AND LOCAL GOVERNMENT USE:** This Contract may be utilized by and extends to other agencies, spending units, and political subdivisions of the State of West Virginia; county, municipal, and other local government bodies; and school districts ("Other Government Entities"). This Contract shall be extended to the aforementioned Other Government Entities on the same prices, terms, and conditions as those offered and agreed to in this Contract. If the Vendor does not wish to extend the prices, terms, and conditions of its bid and subsequent contract to the Other Government Entities, the Vendor must clearly indicate such refusal in its bid. A refusal to extend this Contract to the Other Government Entities shall not impact or influence the award of this Contract in any manner.
- 49. CONFLICT OF INTEREST:** Vendor, its officers or members or employees, shall not presently have or acquire any interest, direct or indirect, which would conflict with or compromise the performance of its obligations hereunder. Vendor shall periodically inquire of its officers, members and employees to ensure that a conflict of interest does not arise. Any conflict of interest discovered shall be promptly presented in detail to the Agency.
- 50. REPORTS:** Vendor shall provide the Agency and/or the Purchasing Division with the following reports identified by a checked box below:
- Such reports as the Agency and/or the Purchasing Division may request. Requested reports may include, but are not limited to, quantities purchased, agencies utilizing the contract, total contract expenditures by agency, etc.
 - Quarterly reports detailing the total quantity of purchases in units and dollars, along with a listing of purchases by agency. Quarterly reports should be delivered to the Purchasing Division via email at purchasing.requisitions@wv.gov.
- 51. BACKGROUND CHECK:** In accordance with W. Va. Code § 15-2D-3, the Director of the Division of Protective Services shall require any service provider whose employees are regularly employed on the grounds or in the buildings of the Capitol complex or who have access to sensitive or critical information to submit to a fingerprint-based state and federal background inquiry through the state

repository. The service provider is responsible for any costs associated with the fingerprint-based state and federal background inquiry.

After the contract for such services has been approved, but before any such employees are permitted to be on the grounds or in the buildings of the Capitol complex or have access to sensitive or critical information, the service provider shall submit a list of all persons who will be physically present and working at the Capitol complex to the Director of the Division of Protective Services for purposes of verifying compliance with this provision.

The State reserves the right to prohibit a service provider's employees from accessing sensitive or critical information or to be present at the Capitol complex based upon results addressed from a criminal background check.

Service providers should contact the West Virginia Division of Protective Services by phone at (304) 558-9911 for more information.

52. PREFERENCE FOR USE OF DOMESTIC STEEL PRODUCTS: Except when authorized by the Director of the Purchasing Division pursuant to W. Va. Code § 5A-3-56, no contractor may use or supply steel products for a State Contract Project other than those steel products made in the United States. A contractor who uses steel products in violation of this section may be subject to civil penalties pursuant to W. Va. Code § 5A-3-56. As used in this section:

- a. "State Contract Project" means any erection or construction of, or any addition to, alteration of or other improvement to any building or structure, including, but not limited to, roads or highways, or the installation of any heating or cooling or ventilating plants or other equipment, or the supply of and materials for such projects, pursuant to a contract with the State of West Virginia for which bids were solicited on or after June 6, 2001.
- b. "Steel Products" means products rolled, formed, shaped, drawn, extruded, forged, cast, fabricated or otherwise similarly processed, or processed by a combination of two or more or such operations, from steel made by the open heath, basic oxygen, electric furnace, Bessemer or other steel making process.

The Purchasing Division Director may, in writing, authorize the use of foreign steel products if:

- a. The cost for each contract item used does not exceed one tenth of one percent (.1%) of the total contract cost or two thousand five hundred dollars (\$2,500.00), whichever is greater. For the purposes of this section, the cost is the value of the steel product as delivered to the project; or
- b. The Director of the Purchasing Division determines that specified steel materials are not produced in the United States in sufficient quantity or otherwise are not reasonably available to meet contract requirements.

53. PREFERENCE FOR USE OF DOMESTIC ALUMINUM, GLASS, AND STEEL: In Accordance

with W. Va. Code § 5-19-1 et seq., and W. Va. CSR § 148-10-1 et seq., for every contract or subcontract, subject to the limitations contained herein, for the construction, reconstruction, alteration, repair, improvement or maintenance of public works or for the purchase of any item of machinery or equipment to be used at sites of public works, only domestic aluminum, glass or steel products shall be supplied unless the spending officer determines, in writing, after the receipt of offers or bids, (1) that the cost of domestic aluminum, glass or steel products is unreasonable or inconsistent with the public interest of the State of West Virginia, (2) that domestic aluminum, glass or steel products are not produced in sufficient quantities to meet the contract requirements, or (3) the available domestic aluminum, glass, or steel do not meet the contract specifications. This provision only applies to public works contracts awarded in an amount more than fifty thousand dollars (\$50,000) or public works contracts that require more than ten thousand pounds of steel products.

The cost of domestic aluminum, glass, or steel products may be unreasonable if the cost is more than twenty percent (20%) of the bid or offered price for foreign made aluminum, glass, or steel products. If the domestic aluminum, glass or steel products to be supplied or produced in a “substantial labor surplus area”, as defined by the United States Department of Labor, the cost of domestic aluminum, glass, or steel products may be unreasonable if the cost is more than thirty percent (30%) of the bid or offered price for foreign made aluminum, glass, or steel products.

This preference shall be applied to an item of machinery or equipment, as indicated above, when the item is a single unit of equipment or machinery manufactured primarily of aluminum, glass or steel, is part of a public works contract and has the sole purpose or of being a permanent part of a single public works project. This provision does not apply to equipment or machinery purchased by a spending unit for use by that spending unit and not as part of a single public works project.

All bids and offers including domestic aluminum, glass or steel products that exceed bid or offer prices including foreign aluminum, glass or steel products after application of the preferences provided in this provision may be reduced to a price equal to or lower than the lowest bid or offer price for foreign aluminum, glass or steel products plus the applicable preference. If the reduced bid or offer prices are made in writing and supersede the prior bid or offer prices, all bids or offers, including the reduced bid or offer prices, will be reevaluated in accordance with this rule.

CERTIFICATION AND SIGNATURE PAGE

By signing below, I certify that I have reviewed this Solicitation in its entirety, understand the requirements, terms and conditions, and other information contained herein; that I am submitting this bid or proposal for review and consideration; that I am authorized by the bidder to execute this bid or any documents related thereto on bidder's behalf; that I am authorized to bind the bidder in a contractual relationship; and that to the best of my knowledge, the bidder has properly registered with any State agency that may require registration.

(Company)

(Authorized Signature)

(Representative Name, Title)

(Phone Number) (Fax Number)

(Date)

ADDENDUM ACKNOWLEDGEMENT FORM
SOLICITATION NO.: 08140024

Instructions: Please acknowledge receipt of all addenda issued with this solicitation by completing this addendum acknowledgment form. Check the box next to each addendum received and sign below. Failure to acknowledge addenda may result in bid disqualification.

Acknowledgment: I hereby acknowledge receipt of the following addenda and have made the necessary revisions to my proposal, plans and/or specification, etc.

Addendum Numbers Received:

(Check the box next to each addendum received)

- | | |
|---|--|
| <input type="checkbox"/> Addendum No. 1 | <input type="checkbox"/> Addendum No. 6 |
| <input type="checkbox"/> Addendum No. 2 | <input type="checkbox"/> Addendum No. 7 |
| <input type="checkbox"/> Addendum No. 3 | <input type="checkbox"/> Addendum No. 8 |
| <input type="checkbox"/> Addendum No. 4 | <input type="checkbox"/> Addendum No. 9 |
| <input type="checkbox"/> Addendum No. 5 | <input type="checkbox"/> Addendum No. 10 |

I understand that failure to confirm the receipt of addenda may be cause for rejection of this bid. I further understand that any verbal representation made or assumed to be made during any oral discussion held between Vendor’s representatives and any state personnel is not binding. Only the information issued in writing and added to the specifications by an official addendum is binding.

Company

Authorized Signature

Date

NOTE: This addendum acknowledgement should be submitted with the bid to expedite document processing.

SPECIFICATIONS

1. **PURPOSE AND SCOPE:** The West Virginia Purchasing Division is soliciting bids on behalf of West Virginia Division of Highways to establish a contract for the one time purchase of five (5) - Prestressed Concrete Plank Beams w/ Accessories for Structure #36-22-4.90, Pump House Drainage Structure.

2. **DEFINITIONS:** The terms listed below shall have the meanings assigned to them below. Additional definitions can be found in section 2 of the General Terms and Conditions.
 - 2.1 **“Contract Item”** means Prestressed Concrete Plank Beams w/ Accessories as described in the Pricing Page and as detailed in the attached sheets.

 - 2.2 **“Pricing Page”** means the pages upon which Vendor should list its proposed price for the Contract Items in the manner requested. The Pricing Page is either included on the last page of this RFQ or attached hereto as Exhibit A.

 - 2.3 **“RFQ”** means the official request for quotation published by the Purchasing Division and identified as 08140024.

 - 2.4 **“Control Prints”** means the drawings and details and are attached hereto as Exhibit B.

3. **GENERAL REQUIREMENTS:**
 - 3.1 **Mandatory Contract Item Requirements:** Contract Item must meet or exceed the mandatory requirements listed below.
 - 3.1.1 **Prestressed Concrete Plank Beams**
 - 3.1.1.1 Prestressed Concrete Plank Beams must be in accordance with West Virginia Division of Highways Standard Specifications Roads and Bridges, adopted 2010 and the current Supplemental Specifications
(<http://www.transportation.wv.gov/highways/contractadmin/specifications/2010StandSpec/Pages/default.aspx>) and the attached control prints.

4. CONTRACT AWARD:

4.1 Contract Award: The Contract is intended to provide Agencies with a purchase price for the Contract Items. The Contract shall be awarded to the Vendor that provides the Contract Items meeting the required specifications for the lowest overall total cost as shown on the Pricing Pages.

4.2 Pricing Page: Vendor should complete the Pricing Page by providing the unit price for each item in the Pricing Page. The Total is the product of the Quantity and the Unit Price for an item. The Grand Total is the sum of the Total column in the Pricing Page. Vendor should complete the Pricing Page in full as failure to complete the Pricing Page in its entirety may result in Vendor's bid being disqualified.

Notwithstanding the foregoing, the Purchasing Division may correct errors as it deems appropriate. Vendor should type or electronically enter the information into the Pricing Page to prevent errors in the evaluation.

5. PAYMENT:

5.1 Payment: Vendor shall accept payment in accordance with the payment procedures of the State of West Virginia. The Vendor must send an invoice to:

West Virginia Division of Highways, District Eight
P.O. Box 1516
Elkins, WV 26241
Attention: Tom Beverage

5.2 Partial Payment of Approved Beams

Upon completion of manufacture/fabrication and approval by the Division of Highways of all beams specified on the purchase order, the vendor may invoice and the Division will pay for the cost of manufacturing the beams, not to exceed 65% of the total cost of the delivered beams. The remaining, 35% or more, may be invoiced when all the beams are delivered. Partial payment for beams shall be subject of the following conditions:

- a. The vendor must request partial payment and furnish an official invoice for the manufactured and approved beams.
- b. The partial payment invoice shall be accompanied by a surety bond equal to the invoiced amount guaranteeing delivery of all items specified on the purchase order.
- c. The vendor shall furnish a statement of approved beams condition and exact storage location.

- d. The vendor shall furnish a legal right-of-entry onto the storage site to Division of Highways' employees and/or agents for the purpose of inspecting, sampling, testing, and removing any or all beams.
- e. The vendor shall certify that the stored beams are suitably marked and identified as property of the Division of Highways and will not be used for any purpose not designated by the Division.

6. DELIVERY AND RETURN:

6.1 Shipment and Delivery: The Vendor shall coordinate with the District 8 Bridge Engineer, (Phone No. [304] 637-0220), the date and sequence of delivery for the contract items. The structure requires a mid-morning delivery to the site. Delivery is an integral part of this purchase order and failure to comply will be cause to initiate a WV-82, Vendor Performance Form. This form will officially notify the West Virginia Division of Purchasing and the Vendor of unsatisfactory performance in the execution of this purchase order and the requirements herein.

6.2 Late Delivery: The Agency placing the order under this Contract must be notified in writing if the shipment of the Contract Items will be delayed for any reason. Any delay in delivery that could cause harm to an Agency will be grounds for cancellation of the Contract, and/or obtaining the Contract Items from a third party.

Any Agency seeking to obtain the Contract Items from a third party under this provision must first obtain approval of the Purchasing Division.

6.3 Delivery Payment/Risk of Loss: Vendor shall deliver the Contract Items F.O.B. destination to the Agency's location.

6.4 Return of Unacceptable Items: If the Agency deems the Contract Items to be unacceptable, the Contract Items shall be returned to Vendor at Vendor's expense and with no restocking charge. Vendor shall either make arrangements for the return within five (5) days of being notified that items are unacceptable, or permit the Agency to arrange for the return and reimburse Agency for delivery expenses. If the original packaging cannot be utilized for the return, Vendor will supply the Agency with appropriate return packaging upon request. All returns of unacceptable items shall be F.O.B. the Agency's location. The returned product shall either be replaced, or the Agency shall receive a full credit or refund for the purchase price, at the Agency's discretion.

6.5 Return Due to Agency Error: Items ordered in error by the Agency will be returned for credit within 30 days of receipt, F.O.B. Vendor's location. Vendor shall not charge a restocking fee if returned products are in a resalable condition.

Items shall be deemed to be in a resalable condition if they are unused and in the original packaging. Any restocking fee for items not in a resalable condition shall be the lower of the Vendor's customary restocking fee or 5% of the total invoiced value of the returned items.

Bridge Inspection Report Sheet

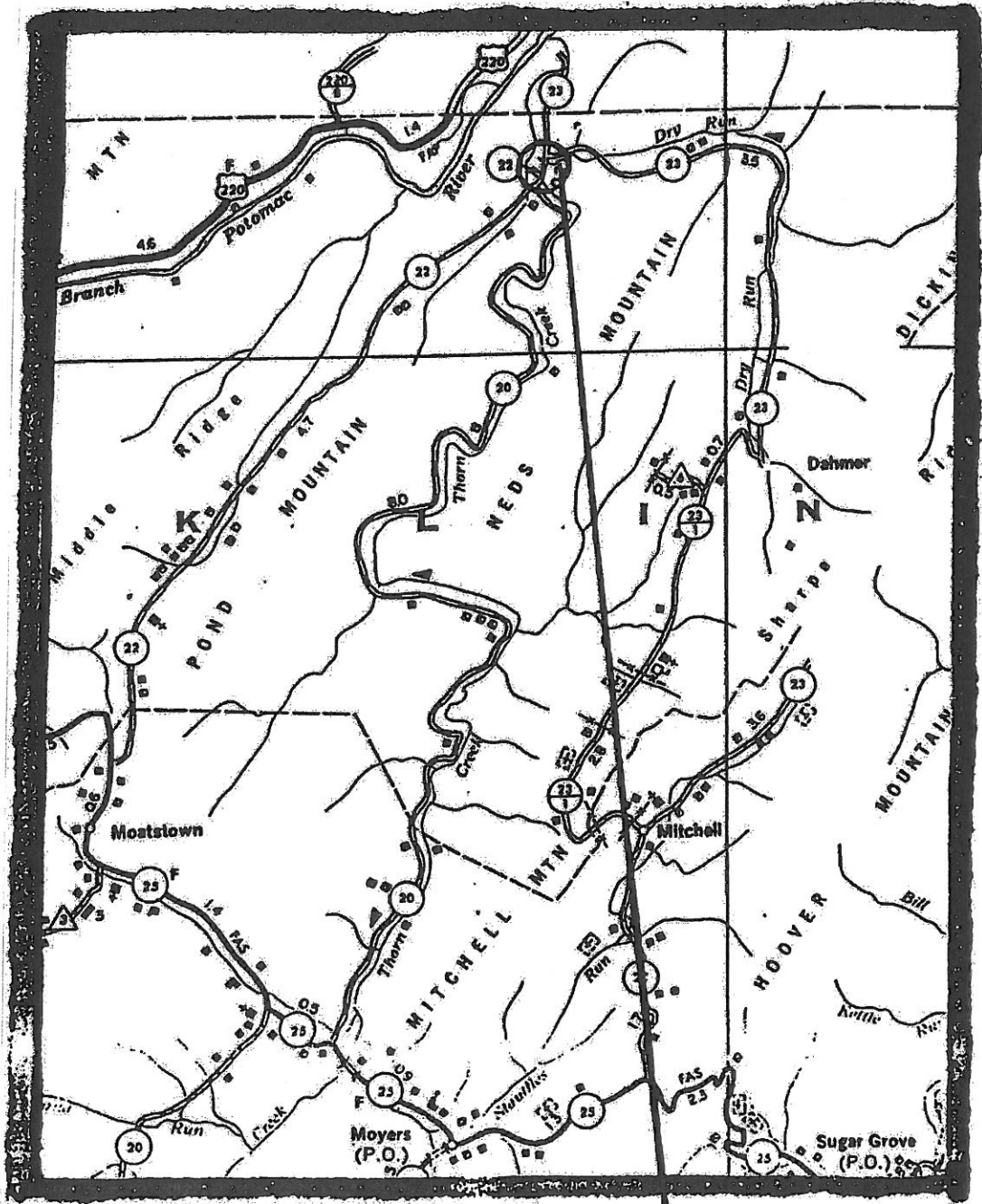

Bridge Number 36-22-A, 90

Pricing Page					
RFQ #08140024					
Item Number	Quantity	Unit of Measure	Description	Unit Cost	Total
1	282	SF	Interior Beam Section; 12" Prestressed Concrete Plank Beams (4 Ft. Wide) 3 Beams x 23'-6" Overall Length		\$
2	188	SF	Exterior Beam Section; 12" Prestressed Concrete Plank Beams (4 Ft. Wide) 2 Beams x 23'-6" Overall Length		\$
3	10	EA	3/4" Elastomeric Laminated Bearing Pads (60 Duro Hardness) 10 Pads (3/4" x 5" x 36")		\$
4	10	EA	1" Diameter x 1'-4" Swedged Anchor Bolt or No. 8 Deformed Reinforcing Bar (Grade 60) Galvanized		\$
5	65.5	SF	1" Thick Sponge Rubber Preformed Joint Filler 40.8 LF @ 12.75" Wide = 43.4 SF 40.8 LF @ 6.5" Wide = 22.1 SF		\$
6	8	EA	Guardrail Attachment Assembly and Guardrail Posts for plank beam w/ plates, pipes, inserts, bolts, nuts, and washers		\$
7	69.8	LF	1" Diameter Post-Tensioning Thread Bars w/ Nuts - 3 Bars @ 23'-3"		\$
8	6	EA	Bearing Plate 9" x 9" x 1"		\$
Grand Total					\$

Requisition 08140024

Items for Structure 36-22-4.90, Pump House Drainage Structure

SECTION 603 PRESTRESSED CONCRETE MEMBERS

603.1-DESCRIPTION:

This work consists of the construction of precast/prestressed concrete members, pretensioned in accordance with these specifications and in conformity with the plan details and notes. This work shall include manufacturing, inspection, handling, storing, transporting and erecting of structural members of precast/prestressed concrete, and, when specified, shall also include precast concrete members which do not contain pretensioning steel components.

Concrete floors, curbs, parapets, curtain walls, and diaphragms shall be cast in place on the project unless otherwise provided for on the plans. When the above elements are specified as precast members, they shall be manufactured in accordance with this specification.

603.2-MATERIALS:

603.2.1 Materials Details: Materials shall meet the requirements specified in the following Sections/Subsections:

Precast/Prestressed Concrete Materials	Sections/Subsections
Cement	ASTM C150, 701.3
#Fine Aggregates	702.1
*Coarse Aggregates	703.1, 703.2, & 703.3
+Admixtures:	
Air Entraining Admixtures	707.1
Retarding Admixtures	707.2
Water Reducing Admixtures	707.3
**Pozzolonic Additives	707.4
Mixing Water	715.7
Reinforcing Steel	709.1
Prestressing Steel	709.2
Hot-Poured Elastic Type Concrete	708.3
Joint Sealer	
Preformed Expansion Joint Filler	708.1
Elastomeric Bearing Pads	715.14
Welded Wire Fabric	709.4
Steel Bolts and Nuts	709.23
Concrete Sealant	707.12
Shear-Key Grout	715.5

- # When the top surface of a prestressed member is designed as the bridge wearing surface
- * The maximum size of coarse aggregate shall not exceed the minimum horizontal or vertical clear spacing between pretensioned or reinforcing steel elements divided by 1.33. Lightweight aggregates shall not be used unless their use is permitted by the Engineer in writing.
- ** The use of a Pozzolonic additive is not permitted when a blended hydraulic cement is used. Unless otherwise permitted by the Engineer, only one source of a Pozzolonic additive shall be used.
- + Calcium chloride or any admixture containing chloride ion in excess of 0.1 percent by weight shall not be used in prestressed concrete members.

603.2.2-Inspection and Testing: A representative of the Engineer shall have free entry at all times, while the work on the Contract is being performed, to all parts of the manufacturer's works which concern the manufacture of the materials ordered. The manufacturer shall afford the representative of the Engineer, without charge, all reasonable facilities to satisfy themselves that the material is being furnished in accordance with these specifications.

603.3-PLANT REQUIREMENTS AND APPROVAL:

603.3.1-Plant Approval: All fabricators of prestressed concrete members shall be certified in the appropriate Group and Category in accordance with the Precast/Prestressed Concrete Institute (PCI) Plant Certification Program. Fabricators shall be certified in Group B3 or B4 for manufacture of prestressed straight strand bridge members. For prestressed draped strand bridge members, the fabricator shall be certified in Group B4. The Engineer or his authorized representative shall approve all plants manufacturing prestressed and precast reinforced concrete bridge members before manufacture of the members may be started. Requests for such approvals shall be submitted to the Engineer at least three weeks prior to the date of manufacture of the members. Requests shall include details of the plant facilities, materials, and the production methods the manufacturer intends to use.

The manufacturer shall have an established quality control program in effective operation at the plant. This program shall be submitted to the Engineer for approval at least 30 days prior to the start of the production.

If a contractor/fabricator is found to consistently deviate from PCI guidelines, the contractor/fabricator will be required to use independent laboratory quality control testing and inspection until it can be shown that conformity with PCI guidelines has been reestablished. The laboratory used is subject to the approval by the Engineer. The cost of the independent laboratory is to be borne by the contractor/fabricator.

603.3.2-Supervision: The contractor/fabricator shall provide a PCI Level II certified technician, skilled in the use of the system of prestressing to be used, who shall supervise the work and give the Engineer or his representative such assistance as may be considered necessary.

603.3.3-Equipment and Tools:

603.3.3.1-General: All equipment, tools and machinery used in the work shall be adequate for the purpose for which it is to be used and shall be maintained in a satisfactory working condition. The use of portable pretensioning beds for the manufacture of prestressed concrete members is not acceptable.

The contractor/fabricator shall provide all other equipment and tools necessary for the construction and the prestressing.

603.3.3.2-Equipment: The jacks shall be equipped with instruments for monitoring the hydraulic pressure. Electronic pressure transducers with digital indicators may be used. All pressure gauges or electronic pressure indicators shall indicate the load directly to one (1) percent of the maximum gauge or sensor/indicator capacity or (2) two percent of the maximum load applied, whichever is smaller.

Each jack and its gauge shall be calibrated as a unit with the cylinder extension in the approximate position that it will be at final jacking force. The calibration of the jack and gauge shall be done while the jack is in the identical configuration as will be used on the site, e.g., same length hydraulic lines. An independent laboratory shall furnish certified calibration charts with each jack and gauge used in the work. Certified calibration of each ram shall be made prior to the start of stressing operations and every six (6) months thereafter, or as requested by the Engineer. Any repair of the rams, such as replacing seals, changing length of hydraulic lines, changing type of pump or using gauges which have not been calibrated with the ram, shall be cause for recalibration of the jack and gauge with a load cell. No extra compensation will be allowed for the initial or subsequent ram calibrations.

603.3.3.3-Forms and Casting Beds: Forms and casting beds shall be subject to the approval of the Engineer. Unless otherwise approved, only metal forms on concrete founded casting beds shall be used. The forms and casting beds shall be well constructed, carefully aligned, substantial and firm, securely braced and fastened together, sufficiently tight to prevent leakage of mortar and strong enough to withstand the action of mechanical vibrators. The forms shall be constructed to permit movement of the members without damage during release of the prestressing force or movement caused by thermal expansion during curing. The casting beds and all form work will be approved before any concrete is placed, but such approval shall not relieve the contractor/fabricator of responsibility for the results obtained.

603.4-WORKING DRAWINGS:

603.4.1-General: The contractor/fabricator shall expressly understand that the Engineer's approval of the working drawings submitted by the contractor/fabricator covers the requirements for "strength and detail," and that the Engineer assumes no responsibility for errors in dimensions.

Working drawings must be approved prior to performance of the work involved and such approval shall not relieve the contractor/fabricator of any responsibility under the contract for the successful completion of the work.

All working drawings shall be in English units. Use of dual (metric and English) units is not allowed.

603.4.2-Shop Drawings: The contractor/fabricator shall submit copies of the detailed shop drawings to the Engineer for approval. Shop drawings shall be submitted sufficiently in advance of the start of the work to allow time for review by the Engineer and corrections by the contractor/fabricator without

delaying the work. The size of the original drawings shall be 22 inches x 34 inches (559 mm x 864 mm) including margins, unless otherwise permitted. The shop drawings submitted for approval may be reduced.

Shop drawings for concrete structures shall give full detailed dimensions and sizes of component parts of the structure and details of all miscellaneous parts. Design camber for all members shall be shown on the shop drawings.

603.4.3-Erection Drawings: The contractor shall submit drawings illustrating fully their proposed method of erection. The drawings shall show details of all falsework bents, bracing, guys, dead-men, lifting devices, and attachments to the bridge members: sequence of erection, location of cranes and barges, crane capacities, location of lifting points on the bridge members, and weights of the members. The plan and drawings shall be complete in detail for all anticipated phases and conditions during erection. Design calculations, sealed by a Registered Professional Engineer, shall be submitted by the contractor/fabricator to the Engineer for approval which will demonstrate that allowable stresses for falsework and concrete members being erected are not exceeded and that member capacities and final geometry shall be correct.

When the designated concrete deck overhang exceeds 30 inches (760 mm) , the erection drawings submitted by the contractor/fabricator shall include complete details of the forming and bracing for the overhang and shall transmit the concrete deck dead load to an area of the beam or stringer which will prevent distortion. All forming and bracing procedures are subject to approval of the Engineer.

603.5-REINFORCEMENT:

All reinforcing bars and welded wire fabric shall meet all requirements of Section 602 and shall be free of frost, loose rust, grease, dirt, oil, paint, mill scale, corrosion or other deleterious substances. Any steel which cannot be satisfactorily cleaned shall not be used.

When splicing is required, all reinforcing bars shall be lapped for a length of at least 30 bar diameters.

Reinforcing bars, welded wire fabric and other embedded fixtures shall be accurately placed as indicated on the Plans and shall be maintained in their correct position during the manufacture of the unit. Reinforcement shall not be held in position by tack welding.

The minimum concrete cover for reinforcing steel shall be as follows, unless otherwise shown on the Plans:

- Main Reinforcement 1½ inches (40 mm)
- Slab Reinforcement, top of slab 1½ inches (40 mm)
- Slab Reinforcement, bottom of slab 1 inch (25 mm)
- Stirrups and Ties..... 1 inch (25 mm)

The longitudinal or main wires of welded wire fabric shall be placed transverse to the longitudinal axis of the unit. Laps of welded wire fabric shall be a minimum of 6 inches (150 mm) unless otherwise approved by the Engineer.

603.6 CONCRETE:

603.6.1-General: The composition, proportioning, and mixing of concrete shall be such so as to produce a homogeneous concrete mixture of a quality that will conform to the test and design requirements specified and as noted on the Plans. Concrete for all prestressed members shall have a minimum compressive strength as may be specified on the plans or in the special provisions. Materials used to form voids in the members shall be fabricated from form material acceptable to the Engineer or from cardboard, which has been treated with a waterproofing agent. Any void made from more than one piece of material shall be glued and banded to prevent separation during concreting operations. Any evidence of separation will be cause for rejection. All concrete materials including admixtures shall meet requirements specified in subsection 603.2 and/or as indicated in the plans.

603.6.2-Mix Design: Concrete mixtures must be established initially by methods in accordance with ACI 318, Chapter 5. Mixes may be designed either by a commercial laboratory or by PCI certified concrete plant personnel. Prior to adoption of a mix design as a plant standard, it shall be field tested by use of the production plant batching and mixing equipment, construction methods, and curing to be used in production of the members. The use of a previous mix design can be approved for a project if sufficient test data (30 or more tests) are available from the past year for evaluation (ACI 301, Chapter 3, method).

All design mixes shall be developed using the type of cement, the type and gradation of aggregates, and admixtures proposed for use in plant mixes. The mix design shall also include either compressive strength tests or a penetration resistance test (in accordance with ASTM C 403) that verify the amount of time it takes to achieve a compressive strength of 500 psi (3.5 Mpa). The Engineer shall approve the mix design. When any of these variables are changed, or after a three-year time period, the mix shall be re-evaluated and submitted to the Engineer for approval.

603.6.3-Proportioning of Concrete: Materials shall be proportioned by weight, unless otherwise authorized by the Engineer. The concrete shall contain the minimum amount of water per sack of cement required to obtain satisfactory workability and the specified minimum strength, but in no case shall this amount exceed five gallons per sack (0.44 liter per kg) of cement, including the free water in the aggregate, and /or admixtures. The minimum cement factor shall be seven bags per cubic yard (390 kg per m³) of concrete. Concrete for all members shall be air-entrained with a target air content of seven percent. A working tolerance of plus or minus two percentage points will be allowed. When the ambient temperature is 90 °F (32° C) or higher, a retarding admixture shall be added to the concrete mixture. The Engineer may permit the use of retarding or water-reducing admixture when necessary. Slump shall not exceed 8 inches (200 mm) with the use of high range water reducers

603.6.4-Sampling and Test Methods:

Sampling Freshly Mixed Concrete	AASHTO T 141
Slump of Hydraulic-Cement Concrete	AASHTO T 119
Unit Weight and Yield of Concrete	AASHTO T 121
	AASHTO T 152
Air Content of Freshly Mixed Concrete	or
	AASHTO T 196
Making and Curing Concrete Test Specimens in the Field	AASHTO T 23
Compressive Strength of Cylindrical Concrete Specimens	AASHTO T 22
Temperature of Concrete	ASTM C 1064

Cylinders shall be manipulated and cured by methods identical to those used in curing the concrete members.

Slump, Temperature, and Air Content tests shall be conducted on the first batch of concrete each day and every time that cylinders are fabricated. Slump, Temperature, and Air Content tests shall also be conducted whenever Quality Control Personnel or the Inspector see a variation in the mix.

Unit Weight and Yield tests shall be conducted on the first batch of concrete each day and thereafter, as deemed necessary by Quality Control or Quality Assurance Personnel.

The Fabricator's Quality Control Personnel shall maintain records of the beam number(s) into which each batch of concrete is placed.

603.6.5-Strength of Concrete: Each strength test (i.e. strand release and 28-day) shall consist of the average strength of a minimum of two compressive strength test cylinders fabricated from a single randomly selected batch of concrete, as it is being placed in the forms.

A minimum of one set of cylinders shall be fabricated (at random) for each member cast in a form, with a maximum of one set of cylinders per batch of concrete. These cylinders, molded during fabrication, shall be the same size specimens as were used in the approved mix design.

Any member, for which the average concrete compressive strength at 28-days is less than the 28-day design compressive strength value, may be rejected at the option of the Contractor. If the Contractor elects to use such a member, it will be evaluated as to its adequacy for the use intended. Any member evaluated as unsatisfactory will be rejected by the Division, and the Contractor shall fabricate another member to replace the one which was evaluated as unsatisfactory. When the evaluation indicates that the member will be satisfactory for its intended use, the Engineer will provide for an appropriate price adjustment under the provisions of 603.14.2.1.

603.6.6-Batching and Mixing: Concrete batching plants and their operation shall be in conformance with ASTM C 94, "Specifications for Ready-Mix Concrete". Concrete batch plants shall be capable of producing concrete of the quality required and they shall be adequately equipped and properly operated. Concrete supplied to the plant by an outside batch plant shall meet the same requirements of batch plant facilities. Evidence of

conformance will be certification of the outside plant by the National Ready-Mix Concrete Association (NRMCA).

Fine and coarse aggregates and cement shall be measured by weight. Water and liquid admixture may be measured by either weight or volume. Measurement of the various components of concrete, and measuring equipment shall be in accordance with ASTM C 94.

Concrete shall be mixed by one of the following methods:

1. Central mixed concrete-concrete mixed in a central stationary mixer and delivered to the casting area by appropriate methods.
2. Shrink mixed concrete-concrete that is partially mixed in a stationery mixer, then mixed completely and delivered to the casting site in a truck mixer.
3. Truck mixed concrete-concrete that is completely mixed in a truck mixer as it is delivered to the casting site.

Mixing times shall be established by uniformity tests in accordance with procedures in ASTM C 94.

603.6.7-Placing Concrete: Suitable means shall be used for placing concrete without segregation. The concrete mixture shall not be dropped from a distance of more than 4 feet (1.2 meters), relative to the top of the form or the reinforcement. Special care shall be taken to deposit the concrete in its final position in each part of the form. Working of flowing concrete along the forms from the point of deposit will not be permitted. Care must be taken to work the concrete under and around the prestressing strands and reinforcement. The plastic concrete shall be consolidated in place by either external or internal vibration, or both when necessary. The vibrators shall be of a type and design approved by the Engineer, and the size of the vibrating head will be governed by the spacing of the prestressing cables and reinforcement. Vibrators may be used only to consolidate the concrete after it has been properly placed.

Internal vibrators shall be operated vertically and shall be slowly pushed into and pulled out of the concrete and shall not be held in one spot long enough to cause segregation. Concrete segregated by the vibrator shall be removed and discarded. Partially hardened layers of concrete shall not be penetrated or disturbed by the vibrator. Transmission of vibration into prestressing cable or reinforcement embedded in partially hardened concrete by the vibrating equipment will not be permitted.

603.6.8-Cold Weather Production: In addition to the requirements of Subsection 601.9.1, the following requirements shall apply to outdoor casting operations. When ambient temperatures below 40° F (4° C) are anticipated, the following shall be used as necessary to keep the temperature of concrete within the prescribed limits:

1. Minimum concrete temperature shall be 50° F (10° C) after placement.

2. Concrete shall not be placed on cold forms, steel, or appurtenances. When the temperature of these facilities are below 40° F (4° C), steam heat or other means shall be provided to maintain the temperature to at least 50° F (10° C) unless concrete is delivered above 60° F (15° C) and no frost, snow or ice is present in the form.
3. Placing concrete under covers or in suitable enclosures.
4. Use of heated mixing water.
5. Avoidance of the use of frozen aggregate or aggregate containing frost, snow or ice.
6. Use of insulated forms.

603.6.9-Hot Weather Production: In addition to the requirements of Subsection 601.9.2, the following requirements shall apply to outdoor casting operations:

When the ambient temperature is above 100° F (38° C), or other adverse weather conditions are present, it is recognized that plastic shrinkage of concrete, or loss of strength below specification requirements, or both may occur. If such conditions do occur, the following procedures or combination of procedures shall be used as necessary to correct these deficiencies:

1. Water fog spraying of forms, prior to placement of concrete. Forms exposed to direct sunlight can be misted for cooling prior to placement of concrete.
2. Shaded storage for aggregates.
3. Burying, insulating or shading water supply facilities.
4. Sprinkling or fog spraying of aggregates.
5. Use of shaved or crushed ice for a portion of the mixing water. Only so much ice shall be used as will be entirely melted at the completion of the mixing period.
6. Use of cold water in batching. Water can be chilled and stored in an insulated tank or pulled from a source if temperatures are low enough to aid mix temperature reduction.
7. Application of wet burlap or mats or fog spraying as soon as the water sheen disappears from the concrete. This is especially important for hot, windy, exposed locations.
8. Use of white pigmented curing compound for its heat-reflective properties except on composite surfaces.
9. Use of self-retarding admixtures.
10. Avoidance of the use of cement with temperatures over 170° F (77° C).
11. Shading of product surface during and after casting to avoid heat buildup in direct sunlight.

Concreting operations shall be discontinued when concrete temperatures exceed 100° F (38° C) at the time of placing.

603.7-PRESTRESSING:

603.7.1-Protection of Prestressing Steel: All prestressing steel shall be protected against physical damage and rust at all times during storage and manufacturing. Prestressing steel shall also be free of deleterious material such as grease, oil, wax, or paint, except where called for on the plans. Prestressing steel that has sustained physical damage at any time shall be rejected. The use of prestressing reinforcement having kinks, bends, nicks, or other defects will not be permitted. The development of pitting, other than slight rusting shall be cause for rejection.

Prestressing steel shall be packaged in containers or shipping forms for the protection of the strand against physical damage and corrosion during shipping and storage. A corrosion inhibitor which prevents rust or other results of corrosion shall be incorporated in a corrosion inhibitor carrier type packaging material, or when permitted by the Engineer, may be applied directly to the steel. The corrosion inhibitor shall have no deleterious effect on the steel or concrete or bond strength of steel to concrete.

The shipping package or form shall be clearly marked with a statement that the package contains high strength prestressing steel, and the type of corrosion inhibitor used, including the date packaged.

All anchorages, end fittings, couplers, and exposed strands, which will not be encased in concrete or grout in the completed work, shall be permanently protected against corrosion.

If an anti-bonding agent is used on the forms to facilitate member removal, every precaution shall be taken to protect the prestressing strands against any degree of coating by the anti-bonding agent.

603.7.2-Storing of Prestressing Steel: Prestressing steel shall be stored in a protected area which includes a roof (and sides if necessary) to keep moisture off the strand. In addition the cover must have a floor or at least the strand must be placed on supports to keep it out of mud and water until it is to be used. It shall not be removed from its protective packaging until immediately prior to installation in the forms and placement of concrete. Openings in the packaging shall be resealed as necessary to protect the unused steel. While exposed, the steel shall be protected to prevent corrosion.

603.7.3-Placement of Prestressing Steel: Prestressing shall be accurately installed in the forms and held in place by the stressing jack or temporary anchors and, when tendons are to be draped, by hold-down devices. The hold down devices used at all points of change in slope of tendon trajectory shall be of a low-friction type.

603.7.4-Safety Measures: Effective safety measures shall be taken to prevent injuries to personnel due to the breakage of strands or failure of anchorage devices during the tensioning operations. The protection provided shall be adequate and shall permit the inspector to perform his normal duties. When the safety precautions, in the opinion of the Engineer, are inadequate the contractor will revise the procedures or equipment to the satisfaction of the

Engineer. The inspector will abide by the safety rules established by the producer.

603.7.5-Stressing Requirements:

603.7.5.1-General: The provisions set forth in this section refer to the application and measurement of stresses to prestressed concrete members manufactured by the process of pretensioning. Prestressing forces shall not be transferred to any member nor shall end anchors be released before the concrete has attained a minimum compressive strength as specified on the plans or in the special provisions as determined by tests of standard cylinders cured identically as the member.

An initial force shall be applied to each strand such as to develop a load of approximately 10% of the final prestressing load as shown on the plans. A record shall be maintained of the jacking force and elongations thereby. Several prestressed members may be cast in one continuous line and stressed at one time.

Forms shall be removed and members detensioned immediately after steam curing or heat curing is discontinued while the concrete is still warm and moist. The elements shall be cut or released in an order such that lateral eccentricity of prestress forces will be a minimum.

603.7.5.2-Tensioning of Strands: In all methods of tensioning, stress induced in the strands shall be determined by monitoring applied force and independently by measurement of elongation. Applied force may be monitored by direct measurement using a pressure gauge piped into the hydraulic pump and jack system. The elongation measurements shall agree with their computed theoretical values within a tolerance of $\pm 5\%$. If discrepancies are in excess of 5% between the calculated forces, determined by elongation measurement and gauge reading, the tensioning operation shall be suspended and the source of error determined, evaluated, and corrected by qualified personnel before proceeding.

Calculations for elongation and gauge readings must include appropriate allowances for friction in the jacking system, strand seating, movement of bulkheads, bed shortening if under load, thermal corrections, and any other compensation for the setup.

603.7.5.3-Methods of Stress Measurement: Methods of measurement of the stressing force consist of pressure gauges to measure force from the pressure applied to hydraulic jacks or any other method approved by the Engineer.

603.7.5.4-Gauging Systems: Hydraulic gauges shall conform to the provisions set forth in Section 603.3.3. All gauges measuring the stressing load shall be graduated so they can be read within a tolerance of $\pm 2\%$.

Tensioning methods employing hydraulic gauges shall have appropriate bypass valve snubbers and fittings so that the gauge pointer will not fluctuate but will remain steady until the jacking load is released.

603.7.5.5-Control of Jacking Force: Pressure bypass valves may be used for stopping the jack at the required load or for manually stopping the load with the valve. The accuracy of setting of automatic cutoff valves shall be verified by running to the desired cutoff load whenever there is reason to suspect improper results, and at a minimum, at the beginning of the operation each day.

603.7.5.6-Wire Failure in Strands: Failure of wires in a pretensioning strand is acceptable provided the total area of wire failure is not more than 2 % of the total area of strands in a member, and providing the breakage is not symptomatic of a more extensive distress condition. Failure of any individual wire prior to placing concrete will require replacement of the strand.

603.7.5.7-Calibration Records For Jacking Equipment: All jacking and load measuring equipment shall be calibrated as specified in Section 603.3.3. Calibration records should show the following data.

1. Date of calibration.
2. Agency, laboratory or registered Professional Engineer (PE) supervising the calibration.
3. Method of calibration; i.e. proving ring, load cell, testing machine, etc., and its calibration reference.
4. The full range of calibration with gauge readings indicated against actual load.

Calibration records for all tensioning systems being used shall be available for preparing theoretical tensioning values. Personnel involved in preparing tensioning calculations shall have a copy of these records for reference.

603.7.6-Pretensioning and Strand Debonding: Pretensioning shall conform to the provisions set forth in Article 2.2, "Pretensioning" of the latest edition of the PCI Quality Control Manual MNL-116.

Plastic sheathing shall be used for strand debonding and shall be approved by the Engineer prior to use. Items such as animal fat, reactive greases, or PVC pipes shall not be used. Any other material shall be approved by the Engineer prior to use.

603.7.7-Detensioning: Detensioning shall conform to the provisions set forth in Article 2.3, "Detensioning" of the latest edition of the PCI Quality Control Manual MNL-116.

603.7.8-Concrete Cover: Minimum concrete cover for prestressing steel shall be 1 ½ inches (40 mm) unless otherwise shown on the plans.

603.8-CURING:

603.8.1 General: Careful attention shall be given to the proper curing of concrete. Prior to placing of concrete, the contractor shall submit the proposed curing methods and procedures to the Engineer for approval. Elevated temperature curing facilities shall be tested prior to approval. Approved equipment and materials for curing shall be available for use prior to casting.

Inadequate curing facilities or lack of attention to the proper curing of concrete shall be sufficient cause for the Engineer to stop all concrete placement until approved curing is provided. Inadequate curing may be cause for rejection of the member. All test cylinders shall be cured in the same environment as the precast/prestressed concrete members.

Curing shall be commenced prior to the formation of surface shrinkage cracks. The curing mats, sheets, or blankets shall be carefully placed in contact with the concrete member to avoid damage to the freshly finished concrete.

The following curing requirements shall apply for precast/prestressed members. Any other special method of curing shall meet with the approval of the Engineer. Concrete shall not be exposed to temperatures below freezing until the specified minimum strength as shown in plan notes has been attained.

All concrete shall be cured by water curing, accelerated temperature curing, or any other method approved by the Engineer.

603.8.2-Water Curing: All exposed surfaces of the concrete shall be kept wet continuously for the required curing time. The water used for curing shall meet the requirements of 603.2. Water curing shall be permitted as follows:

603.8.2.1-Wet Mat Method: For water curing by the mat method, cotton mats, polyethylene sheeting, or polyethylene burlap blankets may be used. The mats, sheets or blankets shall be adequately anchored and weighted to provide continuous contact with all concrete surfaces. Any concrete surfaces which cannot be cured by contact shall be enclosed by mats, adequately anchored, so that outside air cannot enter the enclosure. Sufficient moisture shall be provided inside the enclosure to keep all of the surfaces of the concrete wet for the required curing time, but in no case less than 36 hours.

603.8.2.2-Saturated Cover Curing: The member, covered as specified for the initial phase of curing, shall be maintained on the casting bed in an approved enclosure designed and equipped to insure complete saturation of the covering. The temperature within the enclosure and that of the covering material shall be maintained to provide a uniform curing temperature at the surface of the member, within the limits of 80 °F to 130 °F (27° C) to (54° C), until the specified strength is attained, but in no case less than 36 hours. The covering shall be kept thoroughly saturated throughout the entire curing period and the temperature of the water used shall be controlled uniformly to maintain the selected curing temperature of the surface of the member.

603.8.2.3-Water Spray Curing: The member, covered as specified for the initial phase of curing, shall be maintained in the casting bed in an approved enclosure. When the concrete is sufficiently hardened to resist damage, the covering shall be removed and the exposed surfaces of the unit shall be subjected to a continuous fine spray of water. The temperature within the enclosure and that of the water used shall be controlled to provide a uniform curing temperature at the surface of the member, within the limits of 80 °F and 130 °F (27° C) to (54° C) until the specified member strength is attained, but in no case less than 36 hours.

603.8.3-Accelerated Curing: Accelerated curing of the concrete shall be done by low pressure steam curing, or radiant heat curing. Transfer of stress shall be accomplished immediately after the heat curing has been discontinued. Accelerated curing shall be applied at a controlled rate following initial set of the concrete as per ASTM C403. Accelerated curing shall be done under suitable enclosures which minimize all heat losses and maintain uniform cure conditions within the enclosed area. Members must be maintained wet during accelerated curing time.

If accelerated curing is used, the contractor/fabricator shall furnish recording thermometers showing the time-temperature relationship of the concrete throughout the entire curing period. Recording thermometers shall be kept in proper calibration and recalibrated at least annually.

603.8.3.1-Low-Pressure Steam Curing: Low-pressure steam curing shall be done under a suitable enclosure to contain the live steam and minimize moisture and heat losses. The concrete shall be allowed to attain its initial set before application of the live steam.

Application of live steam shall not be directed on the concrete or forms such as to cause localized high temperatures. During the initial application of live steam, the concrete temperature shall be raised at an average rate not exceeding 80 °F(27° C)/per hour, until the curing temperature is reached. The maximum sustained concrete temperature during the curing cycle shall not exceed 160° F (70° C). The maximum temperature shall be held until the concrete has reached the required release strength. The maximum peak concrete temperature during the curing cycle shall be 190 °F (88° C). The concrete temperature shall be maintained uniformly throughout the extremities of the prestressed member. At the end of curing, the concrete temperature shall be reduced at an average rate not exceeding 50° F (10° C)/per hour.

603.8.3.2-Radiant Heat Curing: Radiant heat may be applied by means of pipes circulating steam, hot oil or hot water, or by electric heating elements. Radiant heat curing shall be done under a suitable enclosure to contain the heat, and moisture loss shall be minimized by covering all exposed concrete surfaces with a plastic sheeting or by applying an approved liquid membrane curing compound to all exposed concrete surfaces. The heat application shall be maintained to create a uniform concrete temperature throughout the extremities of the member.

After the waiting period prior to application of the heat, the concrete temperature shall increase at an average rate not exceeding 80° F (27° C)/per hour until the curing temperature is reached. The maximum sustained concrete temperature within the curing cycle shall not exceed 160° F (70° C). The maximum temperature shall be held until the concrete has reached the required release strength as shown in plan notes. The maximum peak concrete temperature during the curing cycle shall be 190° F (88° C). The maximum cooling rate from sustained concrete curing temperature shall be 50° F (10° C)/per hour.

603.9-FINISHING:

To assure the production of well formed matching members, all surfaces of the concrete shall be finished, shall be true and even, and shall be free from rough, open, or honeycombed areas, depressions or projections. The edges shall be finished or chamfered, or both. Care shall be exercised in removing forms to avoid spalling or otherwise damaging the concrete.

Top surfaces of prestressed members shall be screeded or rough floated to bring mortar to the surface and cover all aggregate. The top surface of members that will receive cast-in-place concrete on the project site shall be finished as noted on the project plans, or if no finish is noted, they shall have either a raked or stiff broom finish. Aggregate shall not be loosened when roughening the surface. The fascia surfaces of bridge members shall be finished with a PCI Grade A Formed Finish. All other members shall be finished with a PCI Standard Grade Formed Finish. Concrete on exposed reinforcing steel and loose laitance on concrete surfaces to be in contact with cast-in-place concrete shall be removed from all members.

Fabrication holes, except box beam vent holes, in the bottom of all beams, shall be filled with nonshrink mortar and made flush with the surrounding surface. No patching is required for small holes and irregularities on the sides of adjacent box beams that are to be sandblasted prior to shipment. Care shall be taken in final cutting the ends of strands to avoid damaging the concrete surface.

603.10-WORKMANSHIP:

603.10.1-General: Holes and voids in the surface of concrete resulting from bolts, ties, or large air pockets shall be wetted and filled with mortar having the same proportion of fine aggregate and cement as in the concrete, after which exposed mortar surfaces shall be finished smooth and even with a wood float.

Surfaces to be repaired and finished shall be kept wet for at least one hour before hydraulic cement mortar is applied. Immediately following patching work, repaired areas shall be wet cured for at least 48 hours. The wet cure may be accomplished by the use of steam, wet burlap or continuous spray wetting. A liquid membrane-curing compound may be used on non-composite surfaces.

Beams or girders having honeycomb of such extent to affect their strength or resistance to deterioration will not be accepted.

603.10.2-Defects and Breakage:

Defective or damaged members which cannot be satisfactorily repaired, or which are not acceptable to the Engineer will not be incorporated into the work. All other members that sustain damage during fabrication, handling, storage or transportation shall be evaluated in accordance with Chapter three of PCI Journal Vol. 30, # 3 entitled "Fabrication and Shipment Cracks in Precast or Prestressed Beams and Columns", hereinafter referred to as "specification". This specification is to be used to determine the severity of cracks. All cracks with a width of 4 mils (0.1 mm) or less may be repaired by silane treatment if the repair section of the specification allows repairs. All cracks over 4 mils (0.1 mm) to and including 16 mils (0.4 mm) shall be repaired by epoxy injection if allowed by the specification. Members with cracks over 16 mils (0.4 mm) shall not be incorporated into the work unless approved by the Engineer.

603.11 DIMENSIONAL TOLERANCES:

All tolerances shall be applied with respect to the theoretical positions and dimensions shown in the plans. The tolerances listed in this article represent the total allowable tolerance that will be accepted in the finished product.

The limits of tolerance do not necessarily represent fully acceptable construction; they are the limits at which construction becomes unacceptable. In general, workmanship shall be at a level of quality that will be well within the tolerance limits. Out of tolerance dimensions shall be handled in accordance with MP 603.10.40.

603.11.1 Prestressed Concrete I-Beams and Bulb Tee Beams:

<i>Characteristics</i>	<i>Value</i>
Depth (flanges)	±1/4 inch (± 6 mm)
Depth (Overall)	+1/2 inch, to -1/4 inch (+15 to -6 mm)
Width (flanges)	+3/8, to -1/4 inch (+10 to -6 mm)
Width (Web)	+3/8, to -1/4 inch (+10 to -6 mm)
Length of Beam	±1/8 inch per 10 feet, ±1 inch max. (± 1 mm/m, 25 mm max)
Sweep (variation from straight line parallel to centerline of member)	± 1/8 inch per 10 ft (± 1 mm/m)
Camber variation from design camber	± 1/8 inch per 10 feet ± 1/2 inch max up to 80 feet length ± 1 inch max. over 80 length (± 1 mm/m) (± 13 mm max. up to 24 m length) (± 25 mm max. over 24 m length)
Camber variation from design camber	±3/16 inch per 12 inches ± 1 inch (±15 mm/m, ± 5 mm max)
Position of plates	± 1 inch (± 25 mm)
Position of bearing plates	± 5/8 inch (± 16 mm)
Diaphragm Inserts (spacing between centers of inserts and from centers of inserts to the ends of the beams.)	± 1/2 in (± 15 mm)
Stirrup bars (Projection above top of beam)	± 3/4 inch (± 20 mm)
Stirrup bars (Longitudinal spacing)	± 2 inches (± 50 mm)

<i>Characteristics</i>	<i>Value</i>
Concrete Cover	$\pm 1/4$ in (± 6 mm)
Position of inserts for structural connections	$\pm 1/2$ in (± 15 mm)
Position of hold-down points for draped strands	± 5 inches (± 125 mm)
Position of Inserts	$\pm 1/2$ inch (± 15 mm)
Position of handling devices:	
Parallel to length	± 6 inches (± 150 mm)
Transverse to length	± 1 inch (± 25 mm)
Prestressing strand position (vertical or horizontal).	$\pm 1/4$ inch (± 6 mm)

603.11.2 Precast/Prestressed Concrete Box Beams and Plank Beams:

<i>Characteristics</i>	<i>Value</i>
Depth (Overall)	$\pm 1/4$ inch (± 6 mm)
Depth (top flange)	$+1/2$ inch ($+15$ mm)
Depth (bottom flange)	$+1/2$ inch to $-1/8$ inch ($+15$ to 3 mm)
Width (Overall)	$\pm 1/4$ inch (± 6 mm)
Width (Web)	$\pm 3/8$ inch (± 6 mm)
Length	$\pm 3/4$ inch (± 20 mm)
Sweep (variation from straight line parallel to centerline of member) Up to 40 feet (12 m) length member	$\pm 1/4$ inch (± 6 mm)
40 to 60 feet (12 to 18 m) length member	$\pm 3/8$ inch (± 10 mm)
Greater than 60 feet (18 m) length member	$\pm 1/2$ in (± 15 mm)
Camber variation from design camber	$\pm 1/8$ inch per 10 feet, $\pm 1/2$ inch Max. (± 1 mm/m, ± 15 mm Max)
Variation from specified end Squareness of skew:	$\pm 5/8$ inch (± 16 mm)
Horizontal	$\pm 1/8$ inch per 12 inches $\pm 1/2$ inch Max. (± 1 mm/100 mm, ± 15 mm Max)
Vertical	$1/2$ in (± 15 mm)
Position of tendons Individual	$\pm 1/4$ in (± 6 mm)
Position of Inserts for structural connections	$\pm 1/2$ in (± 15 mm)
Position of handling devices:	
Parallel to length	± 6 inches (± 150 mm)
Transverse to length	± 1 in (± 25 mm)
Position of stirrups:	
Longitudinal spacing	± 1 inch (± 25 mm)
Projection above top	$+1/4$ inch (± 6 mm), $-3/4$ inch (-20 mm)
Position of dowels tubes	$\pm 5/8$ inch (± 16 mm)
Position of hold-down points for draped strands	± 5 inch (± 125 mm)
Position of tie rods tubes:	
Parallel to length	$\pm 1/2$ inch (± 15 mm)
Vertical	$\pm 3/8$ inch (± 10 mm)
Position of slab void:	
End of void to center of tie hole	$\pm 1/2$ inch (± 15 mm)
Adjacent to end block	± 1 inch (± 25 mm)
Concrete Cover	$\pm 1/4$ inch (± 6 mm) $1/4$ inch per 10 feet long. Bars (6 mm per 3 m)

603.11.3-Prestressed Concrete Deck Panels:

<i>Characteristics</i>	<i>Value</i>
Length	± 1/2 in (± 15 mm)
Width	± 1/2 in (± 15 mm)
Nominal Depth	+ 1/4 inch - 1/8 in (+6 mm, -3 mm)
Horizontal Alignment – Deviation from straightness of matting edge of panels	1/8 in (3 mm)
Deviation of ends from plan dimension Horizontal Alignment	± 1/2 in (± 15 mm)
Position of strands :	
Vertical	±1/8 (±3 mm)
Horizontal	± 1/2 in (± 15 mm)
Concrete Cover	± 1/4 inch (± 6 mm) 1/4 inch per 10 feet long. Bars (6 mm per 3 m)

603.12-HANDLING, STORING, TRANSPORTING, AND ERECTION:

The Contractor shall be responsible for proper handling, lifting, storing, hauling, and erection of all members so that they are placed in the structure without damage.

Prestressed members shall be maintained in an upright position at all times and shall be handled and supported in a manner which prevents torsion. No member shall be moved from the casting yard until the member has been accepted.

Storing of members shall be done with adequate blocking so that warpage or cracking will not occur. Blocking will be such that at least 6 inches (150 mm) clearance is maintained above the surface on which the blocking is placed. Placement of the blocking from beam ends shall be at locations not greater than (3) percent of the beam length. Concrete box beams shall be supported by the solid end block area during handling, storage, hauling, and erection. Members which are improperly stored and which become cracked, warped, or otherwise damaged in storage will be subject to rejection.

Members when stacked, shall be separated by blocking capable of supporting the members. The blocking shall be arranged in vertical planes. Stacking of members shall be arranged such that lifting devices will be accessible and undamaged. Stacking shall not exceed two members high.

All concrete beams or girders when erected, shall be securely tied and/or braced unless otherwise shown on the plans. When railroad or roadway traffic must be maintained beneath girders or beams already placed, traffic shall be protected against falling objects during the erection of diaphragms and other structural members, during the placing of cast-in-place concrete, and during the erection and dismantling of forms. Protection shall consist of nets or flooring with openings not larger than 1 inch (25 mm).

When precast / prestressed concrete adjacent box beams are erected, the fit of mating surfaces will be such that excessive grout leakage will not occur. If such fit is not provided the joint shall be filled with grout or sealed with an acceptable caulking suitable to the Engineer.

603.13-CONSTRUCTION OF DECK:

The variation in heights between beams shall not be more than 1/2 in (13 mm) between adjacent box beams where there is no wearing surface. For adjacent box beam bridges with wearing surfaces, the differential shall not exceed 3/4 inches (19 mm).

Dowel bar and lifting bolt holes shall be filled with non-shrink grout. Adjacent box beam units shall be transverse post tensioned by the use of high strength threaded bars, or by other methods as shown on the Plans.

603.14-MEASUREMENT AND PAYMENT:

603.14.1-Method of Measurement: Precast/Prestressed concrete structural members will be measured along the member centerline in linear feet (meter). Deck panels shall be measured by area in square feet (meter) complete in place.

Precast reinforced concrete three-sided structures shall be measured along the centerline of the erected structure in linear feet (meter).

Precast reinforced concrete headwalls and wingwalls for use with precast reinforced concrete three-sided structures shall be measured in square feet (meter) as measured on the exterior face of the member.

603.14.2-Basis of Payment: Precast/Prestressed concrete beams, deck panels, precast reinforced concrete three-sided structures, and precast reinforced concrete headwalls and wingwalls will be paid for at the contract unit price bid for the items listed below, which price and payment shall be full compensation for furnishing all the materials and doing all the work prescribed in a workmanlike and acceptable manner including the cost of furnishing and manufacturing the concrete members; for labor, concrete, forms, conventional reinforcing steel, prestressing strands, inserts, anchorage devices, bearing pads, shims, grout, wingwalls and headwall connection hardware, joint sealing/waterproofing, and other devices, and for moving, transporting and erecting the finished product in accordance with the Plans and Specifications. For precast reinforced concrete three-sided structures where the headwall is cast integral with the end structure unit, the headwall will be paid for in square feet (meter) as if it were not integral cast. Cast-in-place concrete diaphragms, curb, parapet, railing, and reinforcing steel for cast-in-place concrete are not included in this item.

603.14.2.1-Price Adjustments

Members found not in compliance with the requirements of 603.6.5 for compressive strength, but for which the evaluation indicates may still be used, will be paid for at a reduced contract price in accordance with the following formula:

$$\text{Price Reduction} = \left(\frac{f'_c - \bar{X}}{0.5f'_c} \right) \times \text{CIC}$$

Where:

f'_c = 28-Day Design Compressive Strength, psi (Mpa)

\bar{X} = Average 28-day Compressive Strength as determined in 603.6.5

CIC = Contractor's invoiced cost of the member itself (as billed by the Fabricator)

Note: This cost does not include the cost of items (such as bearing pads, guardrail items, delivery charges, etc.) which are incidental to the cost of member.

603.15-PAY ITEMS:

ITEM	DESCRIPTION	UNIT
603016-*	"size" Prestressed Concrete Box Beam	Linear Feet (Meter)
603017-*	"size" Prestressed Concrete Plank Beam	Linear Feet (Meter)
603018-*	"size" Prestressed Concrete I Beam	Linear Feet (Meter)
603019-*	"size" Prestressed Concrete Bulb T Beam	Linear Feet (Meter)
603020-*	"size" Prestressed Concrete Deck Panel	Linear Feet (Meter)
603021-*	"size" Precast Concrete Deck Panel	Linear Feet (Meter)
603027-*	Precast Reinforced Concrete Three-Sided Structure	Linear Feet (Meter)
603028-*	Precast Reinforced Concrete Wingwall	Linear Feet (Meter)
603029-*	Precast Reinforced Concrete Headwall	Square Feet (Meter)

* Sequence Number

State of West Virginia VENDOR PREFERENCE CERTIFICATE

Certification and application* is hereby made for Preference in accordance with *West Virginia Code*, §5A-3-37. (Does not apply to construction contracts). *West Virginia Code*, §5A-3-37, provides an opportunity for qualifying vendors to request (at the time of bid) preference for their residency status. Such preference is an evaluation method only and will be applied only to the cost bid in accordance with the *West Virginia Code*. This certificate for application is to be used to request such preference. The Purchasing Division will make the determination of the Resident Vendor Preference, if applicable.

1. Application is made for 2.5% resident vendor preference for the reason checked:

- Bidder is an individual resident vendor and has resided continuously in West Virginia for four (4) years immediately preceding the date of this certification; or,
- Bidder is a partnership, association or corporation resident vendor and has maintained its headquarters or principal place of business continuously in West Virginia for four (4) years immediately preceding the date of this certification; or 80% of the ownership interest of Bidder is held by another individual, partnership, association or corporation resident vendor who has maintained its headquarters or principal place of business continuously in West Virginia for four (4) years immediately preceding the date of this certification; or,
- Bidder is a nonresident vendor which has an affiliate or subsidiary which employs a minimum of one hundred state residents and which has maintained its headquarters or principal place of business within West Virginia continuously for the four (4) years immediately preceding the date of this certification; or,

2. Application is made for 2.5% resident vendor preference for the reason checked:

- Bidder is a resident vendor who certifies that, during the life of the contract, on average at least 75% of the employees working on the project being bid are residents of West Virginia who have resided in the state continuously for the two years immediately preceding submission of this bid; or,

3. Application is made for 2.5% resident vendor preference for the reason checked:

- Bidder is a nonresident vendor employing a minimum of one hundred state residents or is a nonresident vendor with an affiliate or subsidiary which maintains its headquarters or principal place of business within West Virginia employing a minimum of one hundred state residents who certifies that, during the life of the contract, on average at least 75% of the employees or Bidder's affiliate's or subsidiary's employees are residents of West Virginia who have resided in the state continuously for the two years immediately preceding submission of this bid; or,

4. Application is made for 5% resident vendor preference for the reason checked:

- Bidder meets either the requirement of both subdivisions (1) and (2) or subdivision (1) and (3) as stated above; or,

5. Application is made for 3.5% resident vendor preference who is a veteran for the reason checked:

- Bidder is an individual resident vendor who is a veteran of the United States armed forces, the reserves or the National Guard and has resided in West Virginia continuously for the four years immediately preceding the date on which the bid is submitted; or,

6. Application is made for 3.5% resident vendor preference who is a veteran for the reason checked:

- Bidder is a resident vendor who is a veteran of the United States armed forces, the reserves or the National Guard, if, for purposes of producing or distributing the commodities or completing the project which is the subject of the vendor's bid and continuously over the entire term of the project, on average at least seventy-five percent of the vendor's employees are residents of West Virginia who have resided in the state continuously for the two immediately preceding years.

7. Application is made for preference as a non-resident small, women- and minority-owned business, in accordance with *West Virginia Code* §5A-3-59 and *West Virginia Code of State Rules*.

- Bidder has been or expects to be approved prior to contract award by the Purchasing Division as a certified small, women- and minority-owned business.

Bidder understands if the Secretary of Revenue determines that a Bidder receiving preference has failed to continue to meet the requirements for such preference, the Secretary may order the Director of Purchasing to: (a) reject the bid; or (b) assess a penalty against such Bidder in an amount not to exceed 5% of the bid amount and that such penalty will be paid to the contracting agency or deducted from any unpaid balance on the contract or purchase order.

By submission of this certificate, Bidder agrees to disclose any reasonably requested information to the Purchasing Division and authorizes the Department of Revenue to disclose to the Director of Purchasing appropriate information verifying that Bidder has paid the required business taxes, provided that such information does not contain the amounts of taxes paid nor any other information deemed by the Tax Commissioner to be confidential.

Under penalty of law for false swearing (*West Virginia Code*, §61-5-3), Bidder hereby certifies that this certificate is true and accurate in all respects; and that if a contract is issued to Bidder and if anything contained within this certificate changes during the term of the contract, Bidder will notify the Purchasing Division in writing immediately.

Bidder: _____ Signed: _____

Date: _____ Title: _____

STATE OF WEST VIRGINIA
Purchasing Division

PURCHASING AFFIDAVIT

MANDATE: Under W. Va. Code §5A-3-10a, no contract or renewal of any contract may be awarded by the state or any of its political subdivisions to any vendor or prospective vendor when the vendor or prospective vendor or a related party to the vendor or prospective vendor is a debtor and: (1) the debt owed is an amount greater than one thousand dollars in the aggregate; or (2) the debtor is in employer default.

EXCEPTION: The prohibition listed above does not apply where a vendor has contested any tax administered pursuant to chapter eleven of the W. Va. Code, workers' compensation premium, permit fee or environmental fee or assessment and the matter has not become final or where the vendor has entered into a payment plan or agreement and the vendor is not in default of any of the provisions of such plan or agreement.

DEFINITIONS:

"Debt" means any assessment, premium, penalty, fine, tax or other amount of money owed to the state or any of its political subdivisions because of a judgment, fine, permit violation, license assessment, defaulted workers' compensation premium, penalty or other assessment presently delinquent or due and required to be paid to the state or any of its political subdivisions, including any interest or additional penalties accrued thereon.

"Employer default" means having an outstanding balance or liability to the old fund or to the uninsured employers' fund or being in policy default, as defined in W. Va. Code § 23-2c-2, failure to maintain mandatory workers' compensation coverage, or failure to fully meet its obligations as a workers' compensation self-insured employer. An employer is not in employer default if it has entered into a repayment agreement with the Insurance Commissioner and remains in compliance with the obligations under the repayment agreement.

"Related party" means a party, whether an individual, corporation, partnership, association, limited liability company or any other form or business association or other entity whatsoever, related to any vendor by blood, marriage, ownership or contract through which the party has a relationship of ownership or other interest with the vendor so that the party will actually or by effect receive or control a portion of the benefit, profit or other consideration from performance of a vendor contract with the party receiving an amount that meets or exceed five percent of the total contract amount.

AFFIRMATION: By signing this form, the vendor's authorized signer affirms and acknowledges under penalty of law for false swearing (*W. Va. Code §61-5-3*) that neither vendor nor any related party owe a debt as defined above and that neither vendor nor any related party are in employer default as defined above, unless the debt or employer default is permitted under the exception above.

WITNESS THE FOLLOWING SIGNATURE:

Vendor's Name: _____

Authorized Signature: _____ Date: _____

State of _____

County of _____, to-wit:

Taken, subscribed, and sworn to before me this ____ day of _____, 20__.

My Commission expires _____, 20__.

AFFIX SEAL HERE

NOTARY PUBLIC _____

Purchasing Affidavit (Revised 07/01/2012)

NOTE:

Vendor and Notary's date must be the same.

Notary required to AFFIX SEAL on Purchasing Affidavit.

Public Roads Div.	State Dist. No.	State Project No.	Federal Project No.	Fiscal Year	County	Sheet No.	Total Sheets
W. V.	8	36-22-4.90		2014	PENDLETON	4	

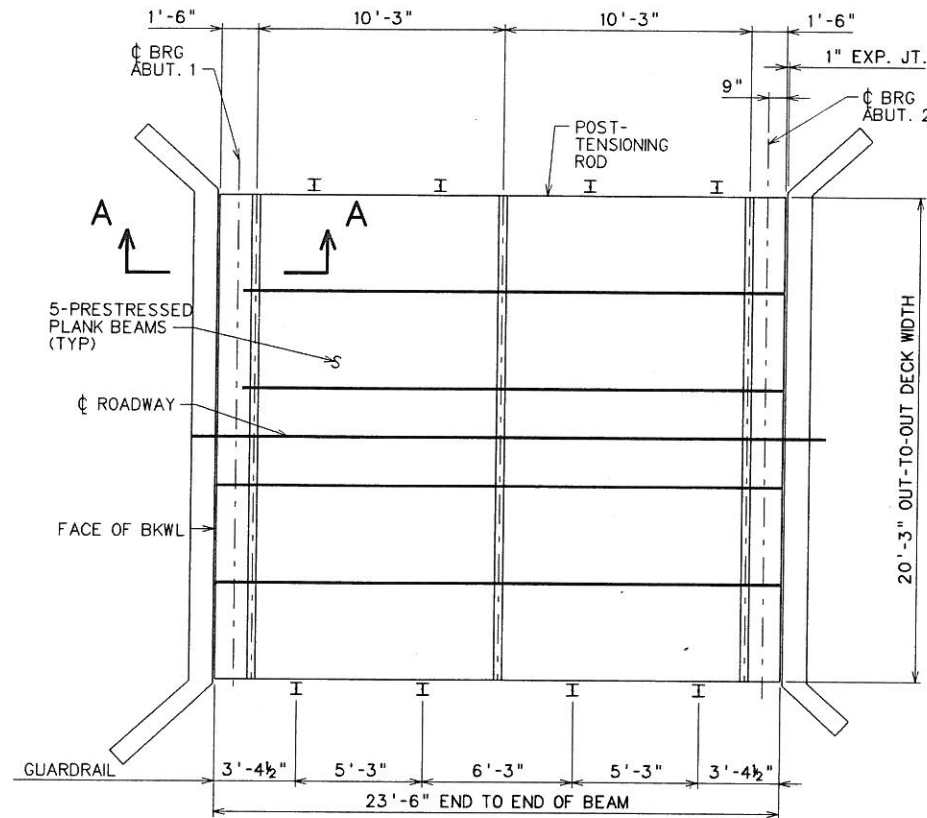

SUPERSTRUCTURE PLAN

SCALE : 0 4 ft.

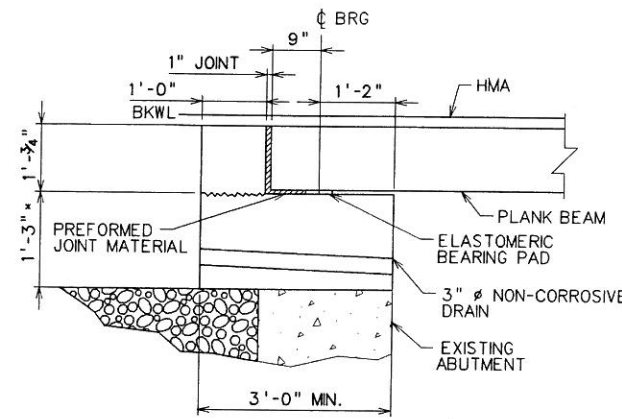

SECTION A-A

* ABUTMENT 2 NEW SEAT HEIGHT = 18"

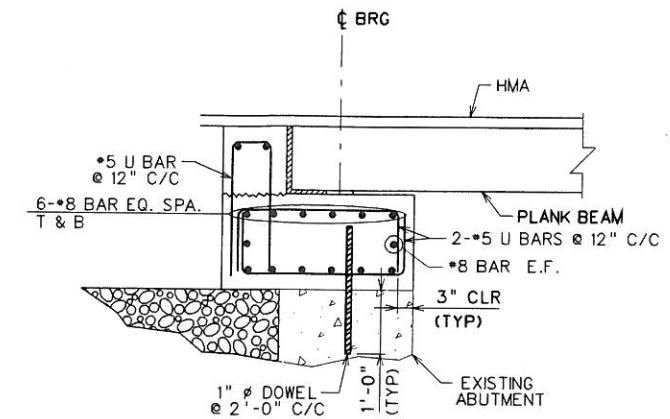

SECTION A-A REINFORCEMENT

NOTE: BENT BARS ARE FIELD BENT

NOTES:

1. SLOPE BEARING SEAT TO MATCH PROFILE GRADE.

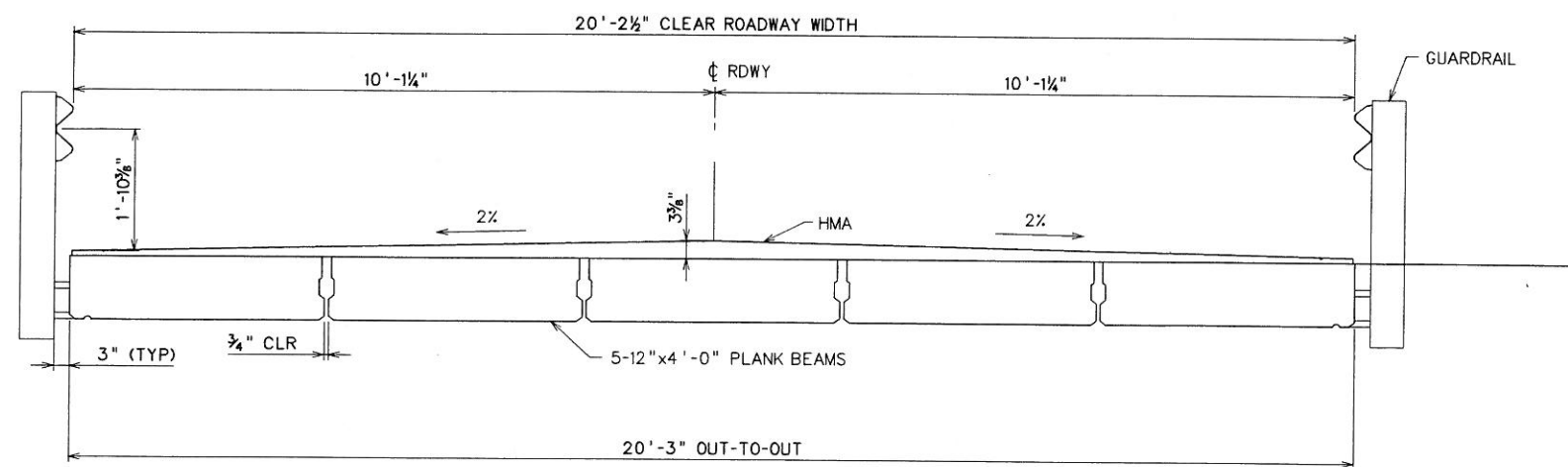

TYPICAL SECTION

SCALE : 0 1.5 ft.

ESTIMATE OF QUANTITIES		
5-12" x 4'-0"x23'-6" PLANK BEAMS	LF SF	117.5 470
CLASS B CONCRETE	CY	10
ELASTOMERIC BEARING PADS	EA	10
APPROACH GUARDRAIL	LF	100
GUARDRAIL POSTS (ON STRUCTURE)	EA	8
CONCRETE BLOCKS	EA	3

DESIGNED	DATE
DRAWN	
CHECKED	
CHECKED	

REVISION NUMBER	SHEET NUMBER	REVISION	DATE	BY

THE WEST VIRGINIA DEPARTMENT OF TRANSPORTATION
DIVISION OF HIGHWAYS

**PUMP HOUSE DRAINAGE
STRUCTURE
OVER DRY RUN
IN PENDLETON COUNTY**

**SUPERSTRUCTURE
PLAN**

SHEET OF BRIDGE NO.

PUBLIC ROADS DIV.	STATE DIST. NO.	PROJECT NUMBER	COUNTY	SHEET NO.	TOTAL SHTS
W. VA.	8	36-22-4.90	PENDLETON	5	10

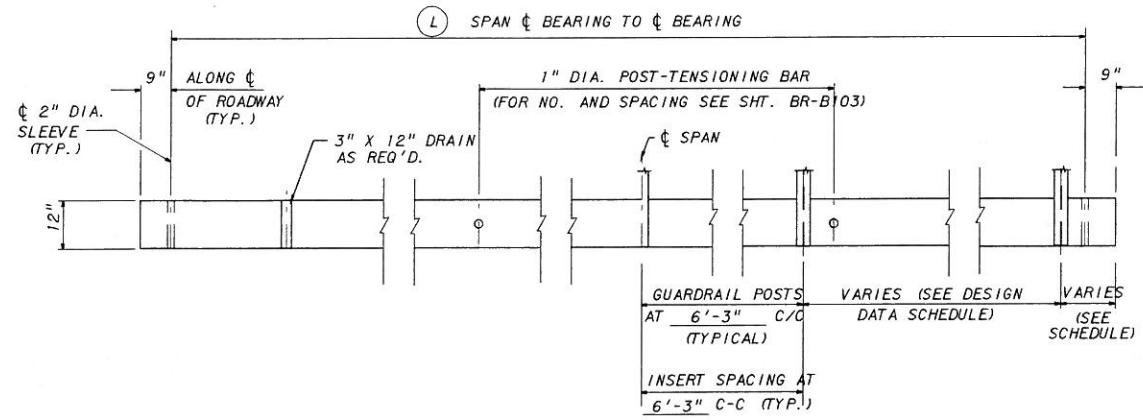

1/2 LONGITUDINAL SECTION 1/2 ELEVATION

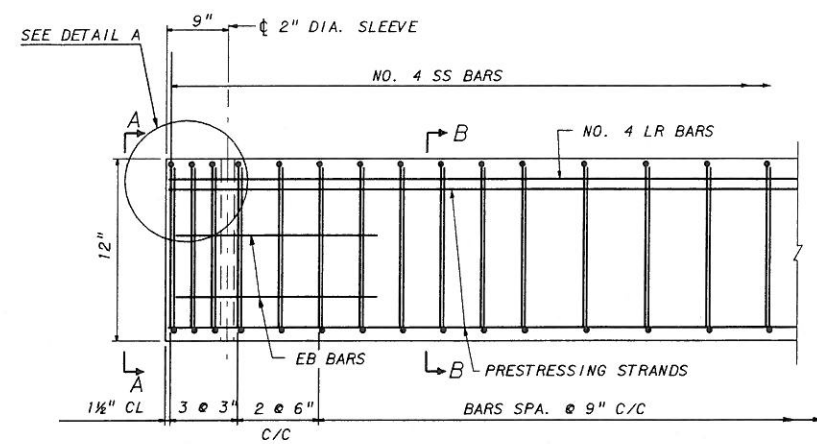

NOTE: SEE SHEET BR-B101 FOR REINFORCING BAR DETAILS AND FOR REINFORCEMENT LAYOUT DETAILS FOR SKEWED BEAMS.

REINFORCING STEEL ELEV. VIEW

- NOTES:
- ALL NON-PRESTRESSING REINFORCING BARS SHALL BE GRADE 60.
 - ALL LAP SPLICE LENGTHS, EXCEPT WHERE SHOWN, SHALL BE AS IN TABLE ON SHEET BR-B101.
 - ALL REINFORCING STEEL BARS SHALL BE EPOXY COATED.
 - ALL STRANDS SHALL BE ENCLOSED INSIDE STIRRUP CAGE ENTIRE LENGTH OF BEAM.
 - THIS SHEET TO BE USED WITH STANDARD SHEET NUMBERS BR-1 OR BR-1A, BR-S12B, BR-B100, BR-B101, BR-B102, BR-B103, AND BR-B104.
 - WHEN STRAND NO. 23 IS USED, SEE SHEET BR-B101 FOR DETAIL OF 2" DIA. ANCHOR SLEEVE. OPTION NO. 2 IS NOT PERMITTED FOR THIS SECTION.

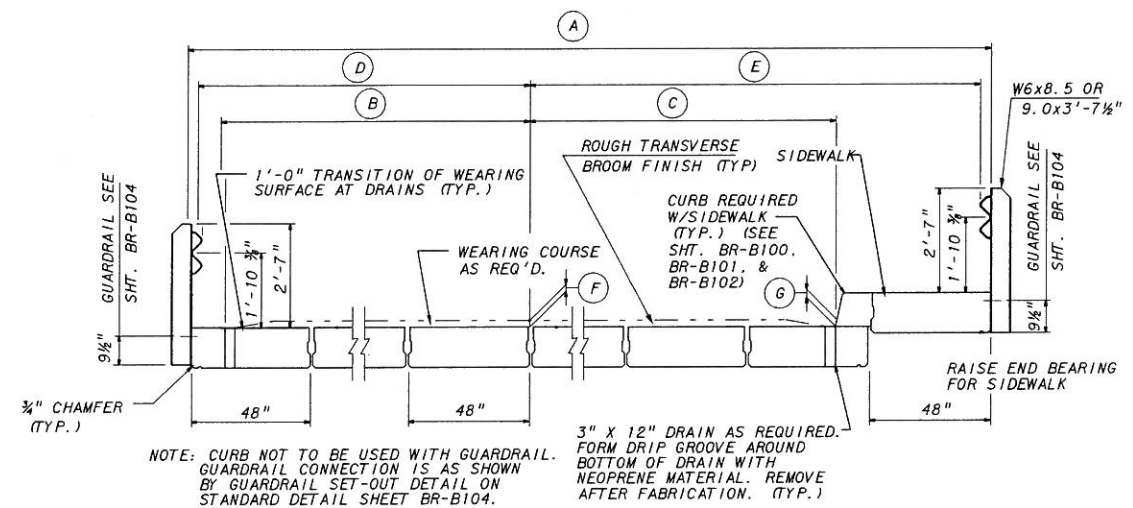

TYPICAL CROSS-SECTION (AT MID-SPAN)

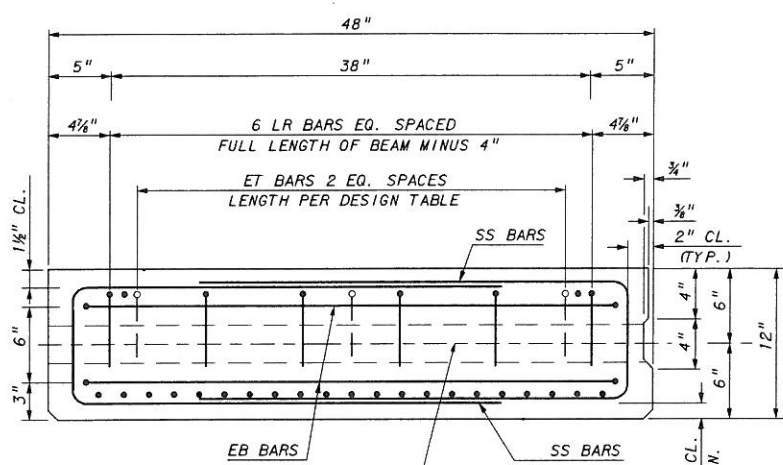

SECTION A-A TYPICAL BEAM REINFORCEMENT

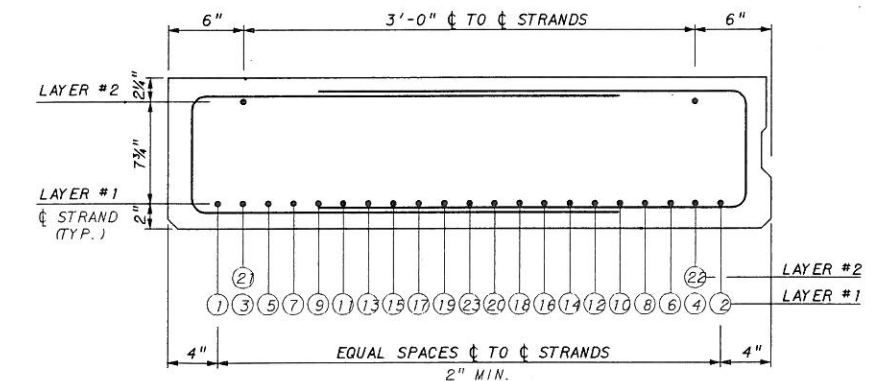

SECTION B-B TYPICAL BEAM PRESTRESSING

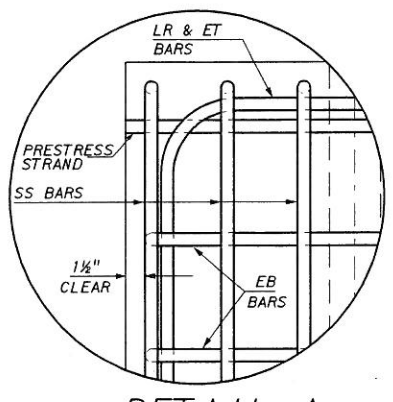

DETAIL A

CONTROL DIMENSIONS		
CODE	DESCRIPTION	VALUE
(A)	DECK WIDTH, OUT TO OUT	20'-3"
(B)	DISTANCE FROM ϕ ROADWAY TO FACE OF CURB (NO SIDEWALK)	N/A
(C)	DISTANCE FROM ϕ ROADWAY TO FACE OF CURB (WITH SIDEWALK)	N/A
(D)	DISTANCE FROM ϕ ROADWAY TO FACE OF GUARDRAIL (NO SIDEWALK)	10'-1 1/4"
(E)	DISTANCE FROM ϕ ROADWAY TO FACE OF GUARDRAIL (WITH SIDEWALK)	N/A
(F)	THICKNESS OF WEARING COURSE AT ϕ ROADWAY	3 3/8"
(G)	THICKNESS OF WEARING COURSE AT FACE OF CURB	1"
(L)	SPAN LENGTH, ϕ BEARING TO ϕ BEARING	22'-0"
	OPTIONAL 10" CURB TO BE INCLUDED (YES OR NO)	NO
	OPTIONAL PARAPET TO BE INCLUDED (REQUIRES SPECIAL DESIGN) (YES OR NO)	NO
	TOE PLATE REQUIRED (YES OR NO)	YES

DESCRIPTION	VALUE
HOT-LAID BITUMINOUS CONCRETE REQUIRED (YES OR NO)	YES
GUARDRAIL REQUIRED (YES OR NO)	YES
DRAINS REQUIRED (YES OR NO)	NO
CURTAIN WALL REQUIRED (YES OR NO)	YES
GUARDRAIL SETOUT REQUIRED (YES OR NO)	YES
GUARDRAIL BLOCKOUT REQUIRED (YES OR NO)	NO

STRANDS _____ TO BE MOVED TO _____ RESPECTIVELY TO ACCOMMODATE DRAIN.

APPROVED: _____ DIRECTOR, STRUCTURES DIVISION _____ DATE _____

WEST VIRGINIA DEPARTMENT OF TRANSPORTATION
DIVISION OF HIGHWAYS-STRUCTURES
12"x4'-0" PRESTRESSED CONCRETE PLANK BEAMS
DESIGN & ASSEMBLY DETAILS
STANDARD SHEET BR-S12A

PREPARED: 9-96
REVISED: _____

THE WEST VIRGINIA DEPARTMENT OF TRANSPORTATION
DIVISION OF HIGHWAYS-STRUCTURES

PUMPHOUSE DRAINAGE STRUCTURE OVER DRY RUN IN PENDLETON COUNTY

12"x4'-0" PRESTRESSED PLANK BEAM DESIGN & ASSEMBLY DETAILS

DESIGNED BY: ANK/
DRAWN BY: JRB,DWW
CHECKED BY: _____
REVIEWED BY: _____
DATE: _____
SCALE: NONE
SHEET NO. _____ OF _____
BRIDGE NUMBER _____

Z:\Design Projects\36-22-4.90 PumpHouse Drainage\BR-S12A\Reinforcing\10h\pumphouse05 - BR-S12A.DGN

PUBLIC ROADS DIV.	STATE DIST. NO.	PROJECT NUMBER	COUNTY	SHEET NO.	TOTAL SHTS
W. VA.	8	36-22-4.90	PENDLETON	6	10

MIN. CONCRETE STRENGTH @ DETENSION = 4,000 PSI.
 MIN. CONCRETE STRENGTH @ 28 DAYS = 5,000 PSI.
 JACKING FORCE / LOW RELAX STRAND = 30,980 LBS.

DESIGN DATA FOR 12" X 4'-0" PLANK BEAM

	10'	11'	12'	13'	14'	15'	16'	17'	18'	19'	20'	21'	22'	(4)	(4)	(4)	(4)
(L) SPAN LENGTH ϕ TO ϕ BEARING	10'	11'	12'	13'	14'	15'	16'	17'	18'	19'	20'	21'	22'				
OVERALL LENGTH ALONG ϕ ROADWAY	11'-6"	12'-6"	13'-6"	14'-6"	15'-6"	16'-6"	17'-6"	18'-6"	19'-6"	20'-6"	21'-6"	22'-6"	23'-6"				
NO. OF GRADE 270. $\frac{1}{8}$ " DIA. LOW-RELAX. STRANDS. AREA/STRAND= 0.153 SQ. IN.	7	8	8	8	8	9	9	10	10	11	12	12	13				
STRAND POSITION NUMBER	1,2,11,12, 21,22 & 23	1,2,9,10, 17,18, 21 & 22	1,2,9,10, 17,18, 21 & 22	1,2,9,10, 17,18, 21 & 22	1,2,9,10, 17,18, 21 & 22	1,2,7,8, 15,16, 21,22 & 23	1,2,7,8, 15,16, 21,22 & 23	1,2,7,8, 13,14,19, 20,21 & 22	1,2,5,6, 13,14,19, 20,21 & 22	1,2,7,8, 13,14,19, 20,21, 22 & 23	1,2,5,6, 9,10,13,14, 17,18, 21 & 22	1,2,5,6, 9,10,13,14, 17,18, 21 & 22	1,2,5,6, 9,10,13,14, 17,18, 21,22 & 23				
PRESTRESSING FORCE AT DETENSION (KIPS/BEAM)	212	241	241	241	241	271	271	300	300	329	358	358	386				
FINAL PRESTRESSING FORCE (KIPS/BEAM)	197	223	223	223	223	249	249	274	275	300	324	325	349				
ULTIMATE DESIGN MOMENT (FT-KIPS/BEAM)	123	135	147	160	173	186	199	213	227	241	255	270	285				
ULTIMATE RESISTING MOMENT (FT-KIPS/BEAM)	162	189	189	189	189	215	215	240	240	264	288	288	310				
TOTAL NUMBER OF DEBONDED STRANDS	-	-	-	-	-	-	-	-	-	-	-	-	-				
LAYER 1-DEBONDED STRAND POSITION NUMBER AND LENGTH FROM EACH END	-	-	-	-	-	-	-	-	-	-	-	-	-				
LAYER 2-DEBONDED STRAND POSITION NUMBER AND LENGTH FROM EACH END	-	-	-	-	-	-	-	-	-	-	-	-	-				
END TENSION STEEL EACH END (SIZE & LENGTH)	3-#4 x 3'-0"	3-#4 x 3'-0"	3-#4 x 3'-0"	3-#4 x 3'-0"	3-#4 x 3'-6"	3-#4 x 3'-6"	3-#4 x 4'-0"	3-#4 x 4'-0"	3-#4 x 4'-0"	3-#4 x 4'-6"	3-#4 x 4'-6"	3-#4 x 5'-0"	3-#4 x 5'-0"				
CAMBER (3)	DETENSION, INCHES +=UPWARD (1in)	0.02	0.04	0.04	0.05	0.05	0.07	0.08	0.11	0.11	0.15	0.19	0.20	0.25			
	ERECTION, INCHES +=UPWARD (1in)	0.04	0.07	0.07	0.08	0.08	0.12	0.13	0.18	0.18	0.24	0.31	0.32	0.40			
	FINAL, INCHES +=UPWARD (1in)	0.05	0.08	0.09	0.09	0.10	0.15	0.15	0.21	0.21	0.28	0.36	0.36	0.45			
WEIGHT OF TYPICAL BEAM (TONS) (1), (2)	3.4	3.7	4.0	4.3	4.6	4.9	5.2	5.5	5.8	6.1	6.3	6.6	6.9				
NUMBER AND SPACING OF GUARDRAIL INSERTS	NO. OF INSERTS	4	4	5	5	5	6	8	6	7	7	7	8	8			
	END OF BEAM TO ϕ OF FIRST INSERT EACH END	1'-9"	1'-9"	1'-9"	1'-9"	1'-9"	1'-9"	2'-3"	1'-9"	1'-9"	1'-9"	1'-9"	2'-10 $\frac{1}{2}$ "	3'-4 $\frac{1}{2}$ "			
	ϕ OF FIRST INSERT TO ϕ SECOND INSERT EACH END	2'-5 $\frac{1}{2}$ "	2'-11 $\frac{1}{2}$ "	1'-10 $\frac{1}{2}$ "	2'-4 $\frac{1}{2}$ "	2'-10 $\frac{1}{2}$ "	1'-9 $\frac{1}{2}$ "	3'-4 $\frac{1}{2}$ "	2'-9 $\frac{1}{2}$ "	1'-9"	2'-3"	2'-9"	5'-3"	5'-3"			

NOTES:

1. BEAM WEIGHTS LISTED IN DESIGN TABLES IS APPROXIMATE AND IS BASED ON ZERO SKEW.
2. FOR STANDARD CURB, ADD 93 LBS. (0.05 TON) PER CURB, PER FOOT OF BEAM.
3. CAMBER VALUES LISTED IN DESIGN TABLE ARE APPROXIMATE AND ARE FOR COMPARISON PURPOSES ONLY. NOT TO BE USED FOR INSPECTION PURPOSES UNLESS PERMITTED BY THE DIRECTOR OF STRUCTURES DIVISION.
4. DATA LISTED IN THE DESIGN TABLE MAY NOT BE VALID FOR SPAN LENGTHS THAT FALL BETWEEN THE SPAN LENGTHS LISTED. IF DIFFERENCES ARE ENCOUNTERED, CALCULATE AND ENTER SPECIFIC DATA FOR BEAM LENGTH REQUIRED IN THIS COLUMN.
5. THIS SHEET TO BE USED WITH STANDARD SHEET NUMBERS BR-1 OR BR-1A, BR-S12A, BR-B100, BR-B101, BR-B102, BR-B103, AND BR-B104.
6. MAXIMUM BEAM SKEW SHALL BE 30 DEGREES.
7. DESIGNER, FABRICATOR AND ERECTOR SHALL BE AWARE THAT SKEWED BEAM ENDS MAY TWIST OR WARP, CAUSING UNEVEN BEAM SEATING AT THE BEARINGS. CONTRACTOR IS REQUIRED TO CORRECT AT THE TIME OF BEAM ERECTION, BEFORE BEAMS ARE SECURED IN PLACE. METHOD OF CORRECTION SHALL PROVIDE EVEN TOTAL BEARING ON THE PADS AND A LEVEL TOP BEAM SURFACE. METHOD SHALL BE A PRE-APPROVED METHOD BY DIRECTOR OF STRUCTURES DIVISION.
8. BEAM FABRICATOR SHALL NOTIFY CONTRACTOR THAT BEAM ENDS ARE TWISTED PRIOR TO SHIPPING OF BEAMS.
9. DEBONDING OF STRANDS IS NOT PERMITTED FOR THIS BEAM SECTION.

APPROVED _____ DIRECTOR, STRUCTURES DIVISION _____ DATE _____

WEST VIRGINIA DEPARTMENT OF TRANSPORTATION
 DIVISION OF HIGHWAYS-STRUCTURES
 DESIGN TABLE FOR 12" X 4'-0"
 PRESTRESSED PLANK BEAM

STANDARD SHEET BR-S12B

PREPARED: 9-96
 REVISED:

THE WEST VIRGINIA DEPARTMENT OF TRANSPORTATION
 DIVISION OF HIGHWAYS-STRUCTURES

PUMPHOUSE DRAINAGE STRUCTURE
 OVER
 DRY RUN
 IN
 PENDLETON COUNTY

DESIGN TABLE FOR 12" X 4'-0"
 PRESTRESSED PLANK BEAM

DESIGNED BY: ANK/
 DRAWN BY: DWN/
 CHECKED BY:
 REVIEWED BY:
 DATE:
 SCALE: NONE
 SHEET NO. OF
 BRIDGE NUMBER

Z:\Design\Projects\36132264.90\BIM\4086430\Drawings\Structure\MicroStation\pumphouse05 - BR-S12B.dgn

PUBLIC ROADS DIV.	STATE DIST. NO.	PROJECT NUMBER	COUNTY	SHEET NO.	TOTAL SHTS
W. VA.	8	36-22-4.90	PENDELTON	7	10

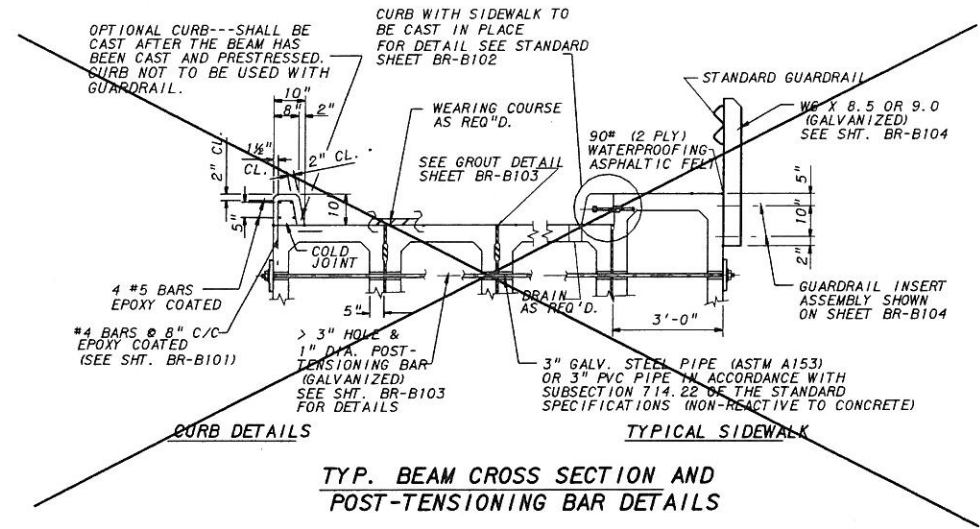

TO FACILITATE GUARDRAIL FABRICATION, STANDARD LENGTH GALVANIZED GUARDRAIL BEAMS MAY BE SAW CUT TO REQUIRED LENGTHS WITH SPLICE AND POST ATTACHMENT HOLES DRILLED AT THE REQUIRED LOCATIONS. HOLES TO BE 1\"/>

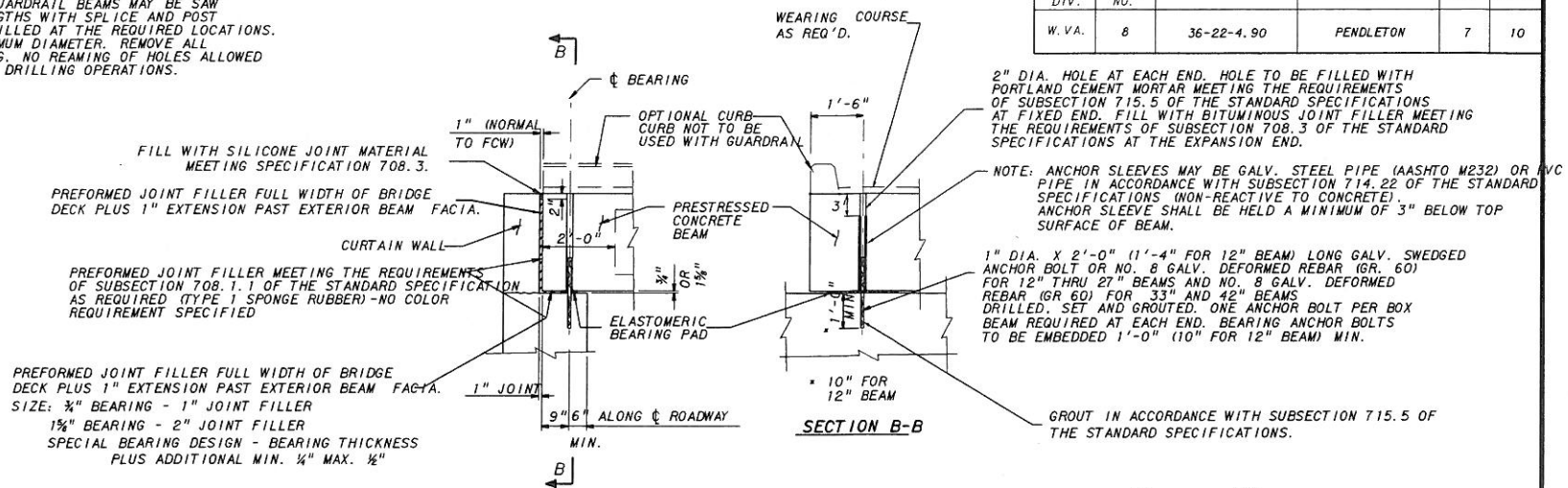

2\"/>

NOTE: ANCHOR SLEEVES MAY BE GALV. STEEL PIPE (AASHTO M232) OR PVC PIPE IN ACCORDANCE WITH SUBSECTION 714.22 OF THE STANDARD SPECIFICATIONS (NON-REACTIVE TO CONCRETE). ANCHOR SLEEVE SHALL BE HELD A MINIMUM OF 3\"/>

1\"/>

GROUT IN ACCORDANCE WITH SUBSECTION 715.5 OF THE STANDARD SPECIFICATIONS.

GOVERNING SPECIFICATIONS

THE WEST VIRGINIA DIVISION OF HIGHWAYS STANDARD SPECIFICATIONS, ROADS AND BRIDGES, ADOPTED 1993, AS AMENDED BY THE SUPPLEMENTAL SPECIFICATIONS OF THE WEST VIRGINIA DIVISION OF HIGHWAYS, CURRENT ISSUE, THE CONTRACT PLANS AND CONTRACT DOCUMENTS ARE THE GOVERNING PROVISIONS APPLICABLE TO THE PROJECT.
THE PRESTRESSED CONCRETE BOX BEAMS SHALL CONFORM TO ALL APPLICABLE PROVISIONS OF THE SECTION 603 OF THE STANDARD SPECIFICATIONS.
ALL REINFORCING STEEL BARS SHALL BE INTERMEDIATE GRADE BILLET STEEL GRADE 60 IN ACCORDANCE WITH SUBSECTION 709.1 OF THE STANDARD SPECIFICATIONS. REINFORCING BARS SHALL BE EPOXY COATED IN ACCORDANCE WITH SECTION 711.35 OF THE STANDARD SPECIFICATIONS.

DESIGN AND FABRICATION NOTES

- ALL MEMBERS ARE DESIGNED FOR 1.25xHS20-44 (HS25) LIVE LOADING IN ACCORDANCE WITH 1992 AASHTO STANDARD SPECIFICATIONS FOR HIGHWAY BRIDGES AS AMENDED BY CURRENT INTERIM SPECIFICATIONS. THE DESIGN PROVIDES FOR A WEARING SURFACE OF 50 POUNDS PER SQUARE FOOT OF ROADWAY. THE DESIGN ALSO PROVIDES FOR AN ADDITIONAL GUARDRAIL SUPERIMPOSED DEAD LOAD OF 30 POUNDS PER LINEAR FOOT OF BEAM AND DIAPHRAGM DEAD LOAD BASED UPON NO. REQ'D. THE DESIGN IS BASED ON A TWO-LANE BRIDGE WITH A DECK WIDTH OF 33'-8\"/>
- COMPRESSIVE STRENGTH OF CONCRETE AT TIME OF PRESTRESSING (f'_c) SHALL NOT BE LESS THAN : 4,000 PSI-17\"/>
- COMPRESSIVE STRENGTH OF CONCRETE AT 28 DAYS (f'_c) SHALL NOT BE LESS THAN : 5,000 PSI-17\"/>
- PRESTRESSING STEEL SHALL BE SEVEN-WIRE UNCOATED LOW RELAXATION STRAND IN ACCORDANCE WITH ASTM A416 GRADE 270 WITH MINIMUM TENSILE STRENGTH (f'_s) OF 270,000 PSI. EXCEPT FOR 42\"/>
- CALCULATED INITIAL STRESSES SHALL NOT EXCEED THE FOLLOWING ALLOWABLE TEMPORARY STRESSES BEFORE LOSSES DUE TO CREEP AND SHRINKAGE: CONCRETE COMPRESSION = 0.60 f'_c; CONCRETE TENSION = 200 PSI OR 3f'_c; PRESTRESSING STEEL = 0.75 f'_s FOR LOW RELAX. STRAND.
- CALCULATED FINAL STRESSES SHALL NOT EXCEED THE FOLLOWING ALLOWABLE SERVICE LOAD STRESSES AFTER ALL LOSSES HAVE OCCURRED: CONCRETE COMPRESSION = 0.40 f'_c; CONCRETE TENSION = 3f'_c; PRESTRESSING STEEL = 0.80 f'_y.
- WHERE THE CALCULATED INITIAL STRESSES EXCEED THE ALLOWABLE STRESS VALUES, STRAND DEBONDING OR TOP STRANDS SHALL BE PROVIDED TO REDUCE THE CALCULATED VALUES TO BELOW THE ALLOWABLE VALUES. ADDITIONALLY, BONDED NON-PRESTRESSED REINFORCEMENT SHALL BE PROVIDED TO RESIST THE TOTAL TENSION.
- ULTIMATE LOAD CAPACITY SHALL NOT BE LESS THAN $\frac{L}{\phi} \geq \frac{30}{\phi} [DL + \frac{1}{2} (LL + I)]$ WHERE $\phi = 1.0$ FOR FACTORY PRODUCED PRECAST PRESTRESSED MEMBERS.
- ALL ANCHOR DOWELS, NON-HEADED ANCHOR BOLTS, GUARDRAIL ATTACHMENT HARDWARE, GUARDRAIL POSTS, CONNECTION PLATES AND DRAIN PLATES SHALL CONFORM TO AASHTO M183 AND SHALL BE HOT-DIP GALVANIZED IN ACCORDANCE WITH AASHTO M111, EXCEPT WHERE NOTED. ALL CAST-IN-PLACE THREADED INSERTS SHALL BE FABRICATED FROM HEX BAR STOCK MEETING THE REQUIREMENTS OF AASHTO M183, ASTM A108 OR A576, GRADE 1020 THRU 1035 OR GRADE 12L14. ALL GUARDRAIL POST ATTACHMENT BOLTS, IN OR OUT OF CONCRETE, SHALL MEET AASHTO M164 OR ASTM A307. NUTS AS REQUIRED SHALL BE HEAVY HEX AND SHALL MEET AASHTO M291. GRADE OF NUTS SUPPLIED SHALL BE AS SHOWN IN TABLE X1.1 OF M291. NUTS MAY ALSO BE SUPPLIED TO AASHTO M292, GRADE 2H. WASHERS SHALL BE CIRCULAR CARBON STEEL MEETING THE REQUIREMENTS OF AASHTO M293. ALL BOLTS, NUTS AND WASHERS SHALL BE HOT-DIP GALVANIZED TO AASHTO M232.
- ALL WELDING TO BE ACCOMPLISHED PRIOR TO GALVANIZING, EXCEPT WHEN NOTED.
- GUARDRAIL END TERMINAL SECTIONS SHALL CONFORM TO THE REQUIREMENTS AS SET FORTH BY THE WEST VIRGINIA DEPARTMENT OF TRANSPORTATION STANDARD DETAILS BOOK VOLUME 1, CURRENT ISSUE.
- DEBONDING OF STRANDS SHALL BE ACCOMPLISHED BY TAPING OR TIGHT-FIT PLASTIC TUBING. LENGTH OF DEBONDING SHALL BE MEASURED FROM ENDS OF BEAM. DEBONDING SHALL BE ACCOMPLISHED BY SHIELDING STRANDS IN A SYMMETRICAL FASHION ABOUT THE CL OF THE BEAM. NUMBER AND LENGTHS OF DEBONDED STRANDS FOR EACH SPAN LENGTH IS GIVEN IN THE PARTICULAR BEAM'S DESIGN DATA TABLE. PLASTIC TUBING SHALL BE TAPED AT BOTH ENDS.
- WHEN ALTERNATE BEAMS ARE TO BE SUPPLIED, THEIR DESIGNS SHALL BE BASED ON LOAD FACTOR DESIGN AND ALLOWABLE STRESS DESIGN AT ALL LOAD STAGES. ADDITIONALLY, ALL BEAMS SHALL BE DESIGNED TO MINIMIZE CAMBER, BUT SHALL HAVE A POSITIVE (UPWARD) CAMBER AFTER ALL LOSSES.
- DEFINITIONS: JACKING FORCE/STRAND-MAX. FORCE IN INDIVIDUAL STRAND BEFORE ANY LOSSES HAVE OCCURRED, AS DEFINED BY AASHTO SPECIFICATIONS INITIAL PRESTRESS FORCE-TOTAL PRESTRESS FORCE IN BEAM AT RELEASE AFTER 10% LOSSES DUE TO ELASTIC SHORTENING, CREEP AND SHRINKAGE HAVE BEEN DEDUCTED.
FINAL PRESTRESS FORCE-TOTAL PRESTRESS FORCE IN BEAM AT SERVICE LOADS AFTER ALL LOSSES HAVE OCCURRED.
- BRIDGE GRADE: DUE TO THE DESIGN OF THE STANDARD ELASTOMERIC BEARING PADS, BRIDGE GRADES SHALL BE LIMITED TO 5 PER CENT OR LESS WHEN USING THESE PADS. IN CASES WHERE THE GRADE MUST BE GREATER THAN 5 PER CENT, A SPECIALLY DESIGNED PAD WILL BE REQUIRED.
- DIMENSIONAL TOLERANCES SHALL BE AS SPECIFIED BY DIVISION VI, SECTION 6.4 OF THE P.C.I. "MANUAL FOR QUALITY CONTROL", 3RD EDITION.
- THIS SHEET TO BE USED WITH STANDARD SHEET BR-1 OR BR-1A, BR-512A, BR-512B, BR-617A, BR-617B, BR-621A, BR-621B, BR-627A, BR-627B, BR-633A, BR-633B, BR-642A, BR-642B, BR-6101, BR-6102, BR-6103, AND BR-6104 AS APPLICABLE.

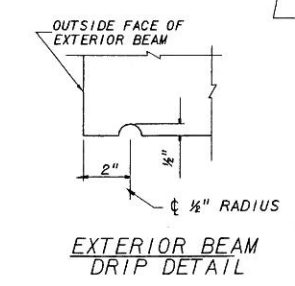
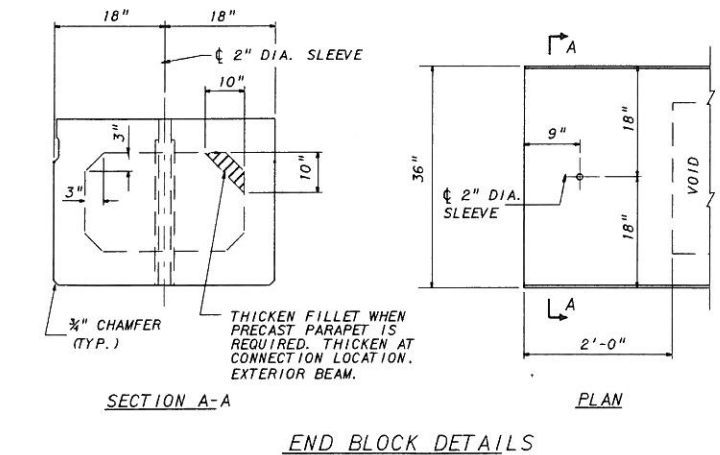
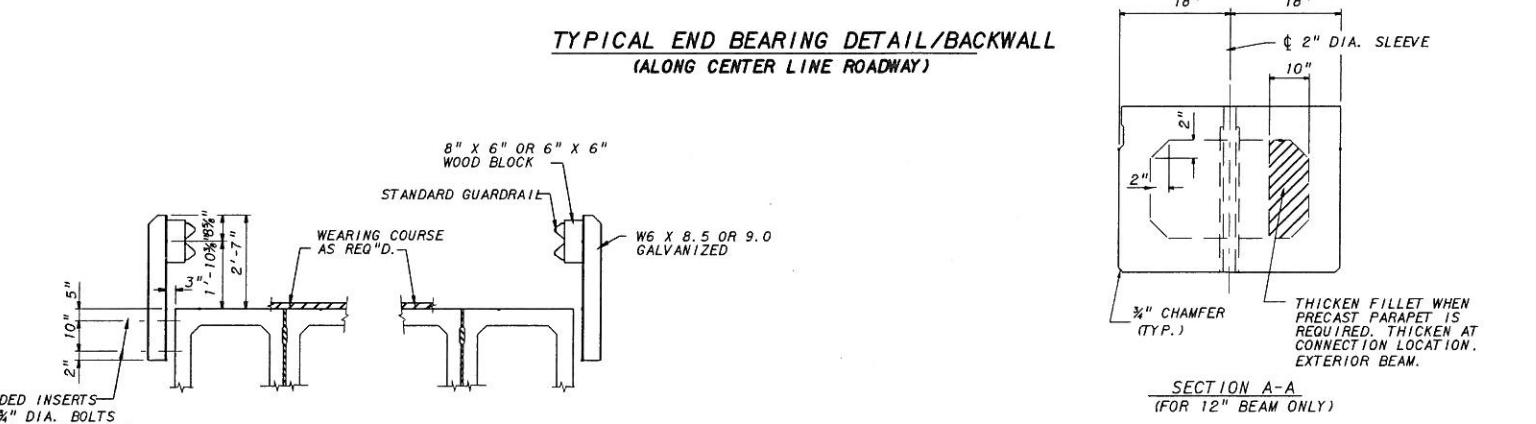

APPROVED: _____	DATE: _____
WEST VIRGINIA DEPARTMENT OF TRANSPORTATION DIVISION OF HIGHWAYS - STRUCTURES PRESTRESSED CONCRETE BEAM DESIGN & ASSEMBLY DETAILS	
STANDARD SHEET BR-B100	PREPARED: 4-1-95 REVISED: 2-96 5-96 9-96

THE WEST VIRGINIA DEPARTMENT OF TRANSPORTATION DIVISION OF HIGHWAYS - STRUCTURES	
PUMPHOUSE DRAINAGE STRUCTURE OVER DRY RUN IN PENDELTON COUNTY	
DESIGNED BY: THB/RCK	DRAWN BY: JRB-DWV
CHECKED BY: RCK	REVISED BY:
DATE: 3/2013	SCALE: NONE
SHEET NO.: 7 OF 10	BRIDGE NUMBER
PRESTRESS CONCRETE BEAM DESIGN & ASSEMBLY DETAILS	
N. A.	

Z:\DesIgn Proj\36-22-4.90\B100\House.Dwg
Dr:RandyStribling\A:\MicroSoft\AutoCAD\2004\Drawings\36-22-4.90\B100.dgn

PUBLIC ROADS Div.	STATE DIST. NO.	PROJECT NUMBER	COUNTY	SHEET NO.	TOTAL SHTS
W. VA.	8	36-22-4.90	PENDELTON	8	10

OPTION NO. 1

TO ACCOMMODATE THE 2" DIAMETER ANCHOR SLEEVE WHEN CENTER STRAND(S) IS/ARE SPECIFIED. STRANDS IN LAYER 1 AND 2 MAY BE MOVED HORIZONTALLY AS LONG AS THEY REMAIN SYMMETRICAL ABOUT THE CENTERLINE OF THE STRAND PATTERN. WHEN NECESSARY TO MOVE STRANDS VERTICALLY, THE ENGINEER SHALL CHECK DESIGN OF NEW PATTERN AND COMPLETE DESIGN TABLE WITH NEW DATA.

OPTION NO. 2

NOTE: WHEN CENTER STRANDS ARE USED, THEY ARE TO BE DEBONDED A MINIMUM OF 1'-0". SEE SPECIFIC DESIGN DATA FOR PROPER DEBOND LENGTH.

NOTE: CUT AND REMOVE LENGTH OF STRAND THAT PASSES THROUGH SLEEVE. THIS IS TO ALLOW CLEARANCE FOR ANCHOR DOWEL.

CUT APPROXIMATELY 1" SLOT TO ALLOW PLACEMENT OF ANCHOR SLEEVE AT CENTER POSITION OF BEAM. WHEN GALVANIZED SLEEVE IS USED, COAT CUT AREAS WITH GALVICON OR EQUAL.

TAPE CUT-OUT PORTION OF SLEEVE TO PREVENT CONCRETE FROM ENTERING ANCHOR HOLE.

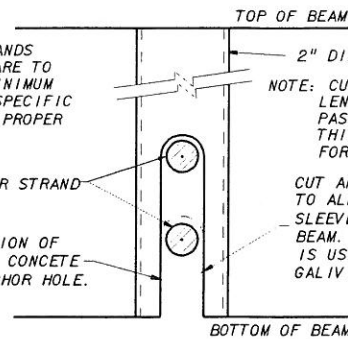

ANCHOR SLEEVE DETAILS
(USE WHEN CENTER STRAND IS SPECIFIED)

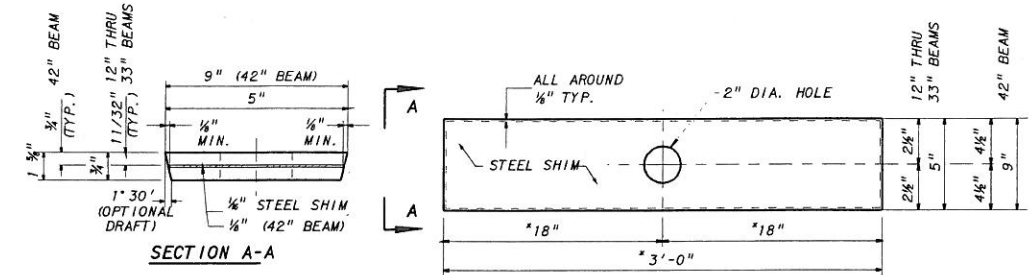

ELASTOMERIC BEARING PAD DETAIL

NOTES: THE BEARING PAD SHALL CONFORM TO AASHTO SPECIFICATIONS FOR HIGHWAY BRIDGES, SECTION 18, DIVISION 11, WITH A DUROMETER HARDNESS OF 60.

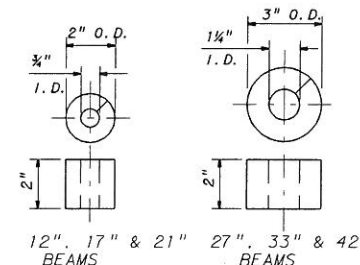

LIFTING LOOP BLOCKOUT DETAILS

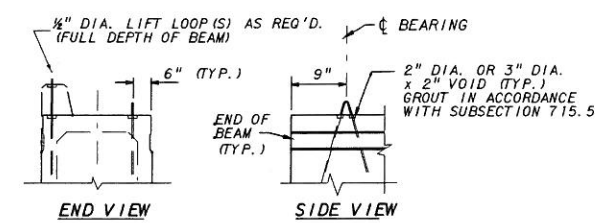

LIFT DETAILS

NOTE: LIFTING LOOPS SHALL NOT BE EPOXY COATED. ON SKEWED BEAMS LIFTING DEVICES SHALL BE LOCATED IN A LINE TRANSVERSE TO THE CENTERLINE OF BEAM.

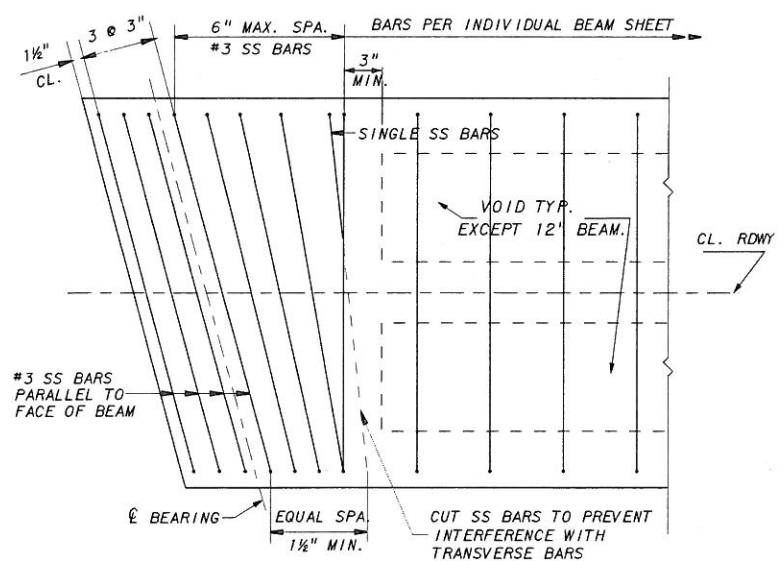

SHEAR REINFORCEMENT DETAIL SKEWED BEAMS

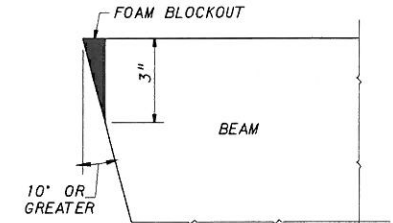

BLOCKOUT DETAIL

NOTES:
1) FABRICATOR SHALL PROVIDE BLOCKOUT OF ACUTE CORNERS ON ALL BEAMS WITH SKEWS OF 10 DEGREES OR GREATER.
2) AFTER ERECTION, ALL INTERIOR BLOCKOUT VOIDS SHALL BE FILLED WITH GROUT IN ACCORDANCE WITH SUBSECTION 715.5 OF THE STANDARD SPECIFICATIONS.

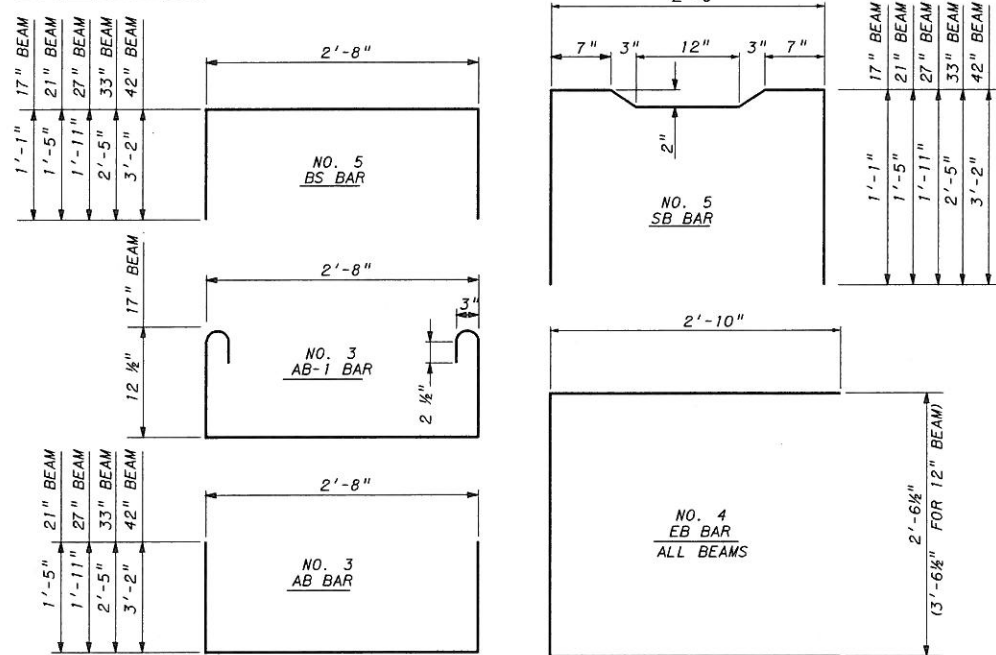
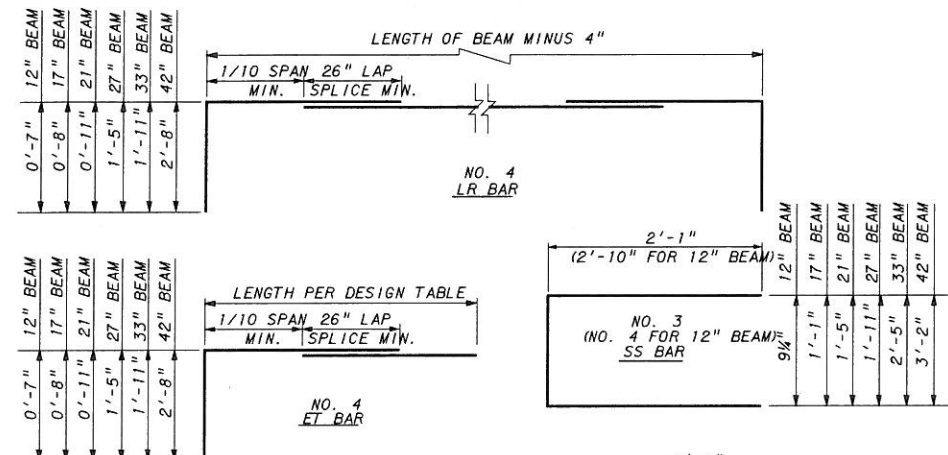
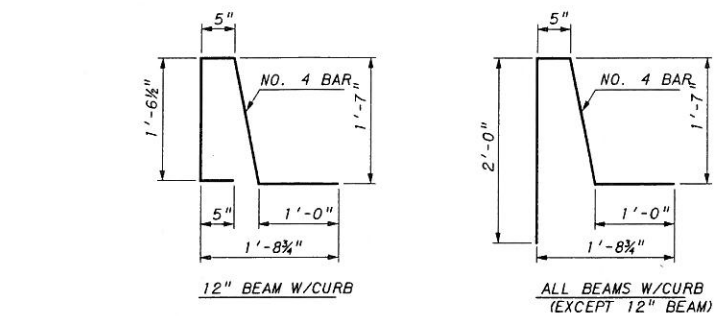

REINFORCING BAR DETAIL

- NOTES
- MINIMUM BAR BENDING DIAMETER SHALL BE 6 BAR DIAMETERS, EXCEPT THAT NO 3 AB AND AB-1 BARS THE MINIMUM BAR BENDING DIAMETER SHALL BE 4 BAR DIAMETERS. ALL DIMENSIONS ARE OUT TO OUT.
 - IF OPTIONAL SPLICING OF LR AND ET BARS IS USED, TERMINATION OF LAP SPLICE SHALL BE NO CLOSER TO THE END OF THE BEAM THAN 1/10 OF THE SPAN LENGTH. ADDITIONALLY ALL LAP SPLICES SHALL BE CONTACT TYPE.

BAR NO.	NO. 3	NO. 4	NO. 5	NO. 6	NO. 7
GRADE	20"	26"	33"	38"	45"

NOTE
THIS SHEET TO BE USED WITH STANDARD SHEET BR-1 OR BR-1A, BR-S12A, BR-S12B, BR-B17A, BR-B17B, BR-B21A, BR-B21B, BR-B27A, BR-B27B, BR-B33A, BR-B33B, BR-B42A, BR-B42B, BR-B100, BR-B102, BR-B103, AND BR-B104 AS APPLICABLE.

APPROVED	DATE
WEST VIRGINIA DEPARTMENT OF TRANSPORTATION DIVISION OF HIGHWAYS-STRUCTURES PRESTRESSED CONCRETE BEAM DESIGN & ASSEMBLY DETAILS	4-1-95
* MODIFIED STANDARD SHEET BR-B101	

THE WEST VIRGINIA DEPARTMENT OF TRANSPORTATION
DIVISION OF HIGHWAYS-STRUCTURES

**PUMPHOUSE DRAINAGE STRUCTURE
OVER
DRY RUN
IN
PENDELTON COUNTY**

PRESTRESSED CONCRETE BEAM
DESIGN & ASSEMBLY DETAILS

DESIGNED BY:	DRAWN BY: DWW
CHECKED BY: RCK	REVIEWED BY:
DATE: 3/2013	SCALE: NONE
SHEET NO.: 8 OF 10	BRIDGE NUMBER
	N. A.

Z:\Design Projects\36-22-4\B2226\pump House Drs\Bng\B101\Structure\Microstation\pumphouse605 - BR-B101.dgn

PUBLIC ROADS DIV.	STATE DIST. NO.	PROJECT NUMBER	COUNTY	SHEET NO.	TOTAL SHTS.
W. VA.	8	36-22-4.90	PENDELTON	9	10

GENERAL NOTES

- POST-TENSIONING THREAD-BARS SHALL BE STRESSED AS FOLLOWS: Z-BARS 80 KIPS AND V-BARS 40 KIPS AFTER FINAL POSITIONING OF BOX BEAMS AND GROUTING OF JOINTS BETWEEN BEAMS. CALCULATED THEORETICAL ELONGATION FOR Z-BAR IS ① INCHES AND FOR V-BAR IS ② INCHES.
- POST-TENSIONING THREAD-BARS SHALL BE ONE INCH DIAMETER, 150 KSI STEEL, AND SHALL CONFORM TO AASHTO M 275, TYPE 11. STEEL THREAD-BARS SHALL BE DESIGNED TO ALLOW THE USE OF HEX NUTS AND COUPLERS THAT THREAD INTO THE DEFORMATIONS. HEX NUTS AND COUPLERS SHALL BE OF A DESIGN AND MATERIAL RECOMMENDED BY THE BAR MANUFACTURER TO DEVELOP THE FULL TENSILE STRENGTH OF THE BAR. PROPERLY DOCUMENTED CERTIFIED WILL TEST REPORTS WILL BE PROVIDED FOR EACH HEAT OF STEEL THREAD-BARS.
- ALL POST-TENSIONING THREAD-BARS, NUTS, BEARING PLATES, COUPLERS AND ANCILLARY HARDWARE SHALL BE HOT-DIP GALVANIZED TO AASHTO M 111. THE GALVANIZING PLANT SHALL ADMINISTER ADEQUATE QUALITY CONTROL MEASURES TO SAFEGUARD AGAINST HYDROGEN EMBRITTLEMENT. QUALITY CONTROL MEASURES SHALL COMPLY WITH ASTM A-143. CERTIFICATIONS FOR HOT-DIP GALVANIZING SHALL BE PROVIDED BY THE GALVANIZING PLANT.
- ALL REINFORCING STEEL SHALL BE GRADE 60 AND EPOXY COATED.
- EACH PRESTRESSED CONCRETE BEAM SHALL BE TREATED BY MANUFACTURER AT THE FABRICATION PLANT WITH AN APPROVED CONCRETE SEALER (SILANE). AN APPROVED LIST OF CONCRETE SEALERS ARE ON FILE AT THE WEST VIRGINIA DIVISION OF HIGHWAYS - MATERIALS CONTROL, SOILS AND TESTING DIVISION. COVERAGE SHALL INCLUDE TOP AND BOTTOM OF INTERIOR BEAMS, AND TOP, BOTTOM AND EXTERIOR SIDE OF EXTERIOR BEAMS. APPLICATION RATE TO BE PER MANUFACTURER'S RECOMMENDATIONS.
- AFTER COMPLETION OF SILANE TREATMENT BY MANUFACTURER AND A MAXIMUM OF FIVE WORKING DAYS BEFORE SHIPMENT OF BEAMS, THE MANUFACTURER SHALL BE RESPONSIBLE FOR SANDBLASTING TO CLEAN WHITE CONCRETE THE INTERIOR SIDES OF BEAMS FOR THE ENTIRE LENGTH. CLEAN WHITE CONCRETE SHALL MEAN REMOVAL OF ALL DIRT, GREASE AND LOOSE PIECES OF CONCRETE AND LEAVE A ROUGHENED SURFACE. BLASTING MEDIUM SHALL BE APPROVED BY THE DIVISION OF HIGHWAYS.
- SHEAR KEY GROUT SHALL BE A GROUT THAT IS RECOMMENDED BY THE MANUFACTURER FOR A POURABLE GROUT APPLICATION AND THAT BASED ON THE MANUFACTURER'S TEST DATA WILL ATTAIN A MINIMUM OF 4500 PSI COMPRESSIVE STRENGTH IN 3 DAYS UNDER CONDITIONS REPRESENTATIVE OF THE CONDITION AT THE SITE. THE GROUT MUST ALSO BE LISTED ON THE APPROVED LIST OF GROUTS PUBLISHED BY THE WEST VIRGINIA DIVISION OF HIGHWAYS, MATERIALS CONTROL, SOIL AND TESTING DIVISION. THE CONTRACTOR SHALL PRE-TEST THE PROPOSED GROUT FOR COMPRESSIVE STRENGTH AT 3 AND 7 DAYS AND SUBMIT THE RESULTS TO THE STRUCTURES DIVISION FOR APPROVAL PRIOR TO INSTALLATION OF THE GROUT IN THE STRUCTURE. THE TESTS WILL BE BASED ON A POURABLE CONSISTENCY WITH THE SAME WATER/GROUT MIXTURE RATIO TO BE USED IN THE STRUCTURE. TEST PROCEDURE SHALL BE THE STANDARD CYLINDER TEST PER AASHTO T 22.
- CONTRACTOR SHALL BE REQUIRED TO SUBMIT FOR EACH PROJECT, THE GROUT PRE-TEST RESULTS OBTAINED IN NOTE 7 ABOVE. CONTRACTOR SHALL BE REQUIRED TO PERFORM A NEW PRE-TEST AND SUBMISSION FOR APPROVAL UNDER THE FOLLOWING CONDITIONS:
 - A PERIOD OF 18 MONTHS HAS ELAPSED SINCE LAST PRE-APPROVAL TESTING; OR
 - GROUT MANUFACTURER HAS REVISED OR CHANGED GROUT SPECIFICATIONS; OR
 - CONTRACTOR ALTERS WATER/GROUT MIXTURE RATIO OR CHANGES GROUT TYPE OR MANUFACTURER.
- CONTRACTOR SHALL BE REQUIRED TO COMPLETE GROUT STRENGTH TABLE.

PROCEDURES

- INSTALL ONE INCH THICK WASHER AND GROUT STOP BY GLUING TO ONE SIDE, FOR THE ENTIRE LENGTH, OF EACH BEAM PRIOR TO SETTING BEAMS. GLUE SHALL BE AN APPROVED CONSTRUCTION TYPE GLUE OR EPOXY ADHESIVE. GROUT STOP MAY BE INSTALLED AFTER BEAMS ARE SET.
- GLUE A 3/4" X 2" X 2" PIECE OF PRESSURE TREATED PLYWOOD AT EACH THREAD-BAR LOCATION TO INSURE THAT A 3/4" GAP IS OBTAINED. OFFSET APPROXIMATELY 2 FEET FROM THE THREAD-BAR HOLE AND CENTERED ON THE HOLE DEPTH. PLYWOOD SPACERS ARE REQUIRED ON ONLY ONE BEAM EDGE AT EACH ADJUTING EDGE (SHEAR KEY LOCATION) AFTER ALL BEAMS ARE SET. THE BEAMS SHALL BE PULLED TOGETHER TRANSVERSELY BY APPLYING A SLIGHT POST-TENSIONING FORCE, APPROXIMATELY 3,000 POUNDS LEAVING A 3/4" GAP BETWEEN BEAMS.
- FILL THE GAP BETWEEN BEAMS AND SHEAR KEY FULL DEPTH WITH THE PRE-APPROVED, PRE-TESTED GROUT MIXTURE. FROM EACH BATCH, PREPARE JOB CONTROL GROUT CYLINDERS FOR THREE AND SEVEN DAY TESTS. THESE JOB CONTROL SAMPLES WILL BE USED TO DETERMINE WHEN THE GROUT'S COMPRESSIVE STRENGTH HAS ATTAINED A MINIMUM OF 4500 PSI. A MINIMUM OF THREE TEST SPECIMENS PER BATCH SHALL BE OBTAINED AND THE AVERAGE OF THE TEST RESULTS USED, EXCEPT THAT IF ONE SPECIMEN SHOWS MANIFEST EVIDENCE OF IMPROPER SAMPLING, MOLDING, OR TESTING, IT SHOULD BE DISCARDED AND THE REMAINING TWO STRENGTHS AVERAGED. SHOULD MORE THAN ONE SPECIMEN REPRESENTING A GIVEN TEST SHOW DEFINITE DEFECTS DUE TO IMPROPER SAMPLING, MOLDING OR TESTING, THE ENTIRE TEST SHALL BE DISCARDED. ACCEPTANCE SAMPLING AND TESTING OF GROUT IS THE RESPONSIBILITY OF THE DIVISION, EXCEPT FOR FURNISHING OF NECESSARY MATERIALS.

TEST PROCEDURE SHALL BE THE STANDARD CYLINDER TEST PER AASHTO T 22.

- AFTER GROUT HAS BEEN PLACED AND HAS REACHED A MINIMUM COMPRESSIVE STRENGTH OF 4500 PSI AS DETERMINED BY TESTS ON JOB CONTROL SAMPLES, AND AFTER GROUT HAS CURED A MINIMUM OF 3 DAYS, APPLY 50% OF THE FINAL POST-TENSIONING FORCE TO ALL THREAD-BARS, WORKING BEAM ENDS TO MID-SPAN. AFTER ALL THREAD BARS ARE TENSIONED TO 50% OF THE POST-TENSIONING FORCE, APPLY REMAINING PERCENTAGE OF FINAL POST-TENSIONING FORCE, TENSIONING IN SAME SEQUENCE AS ABOVE.
- MEASURE AND RECORD, ON THE SPACE PROVIDED ON THE PLANS, THE ACTUAL TOTAL ELONGATION OF EACH THREAD-BAR. COMPARE THE ACTUAL ELONGATION TO THE PREDICTED ELONGATION. A SIGNIFICANT DIFFERENCE IN ACTUAL ELONGATION VERSUS PREDICTED ELONGATION COULD INDICATE IMPROPER JACKING TECHNIQUES, IMPROPER MATERIALS, FAULTY JACK OR IMPROPERLY CALIBRATED JACK. IF THE DIFFERENCE IS MORE THAN 15%, THEN THE JACK WILL BE RECALIBRATED AND THE JACKING TECHNIQUES EVALUATED. IF AFTER RECALIBRATION OF THE JACKS AND ASSURANCE THAT THE JACKING TECHNIQUES ARE SATISFACTORY, THE ELONGATION DIFFERENCE IS MORE THAN 10% FROM THE ESTIMATED ELONGATION THEN THE ENGINEER WILL BE CONTACTED FOR ADVICE.
- USING SAW, TRIM EXCESS THREAD-BAR LEAVING A MINIMUM OF 4" PAST THE NUT. DO NOT TRIM THREAD-BARS BY TORCH CUTTING. TOUCH UP TRIMED ENDS WITH GALVICON, OR EQUAL.
- INSTALL ANCHOR DOWELS AT EACH END.

NOTES

- SHEAR REINFORCEMENT DETAIL FOR BEAMS WITHOUT POCKETS ARE PER STD. SHEET BR-B101.
- T DIMENSION IS PER STD. BEAM SHEET.
- POST-TENSIONING BARS SHOULD BE SPACED TO AVOID INTERFERENCE WITH GUARDRAIL INSERTS.

	3 DAY (ps I)	7 DAY (ps II)
PRE-TEST STRENGTH		
JOB CONTROL STRENGTH		
GROUT TYPE & MANUFACTURER		

BAR	CODE	CALCULATED	MEASURED														
			NO. 1	NO. 2	NO. 3	NO. 4	NO. 5	NO. 6	NO. 7	NO. 8	NO. 9	NO. 10					
Z	①	1/4"															
V	②	1/4"															
CALCULATED ① = W (FT.) / 24.8			ODD NO. BEAMS														
CALCULATED ② = W (FT.) / 99.2			CALCULATED ② = W (FT.) + 3 / 99.2														

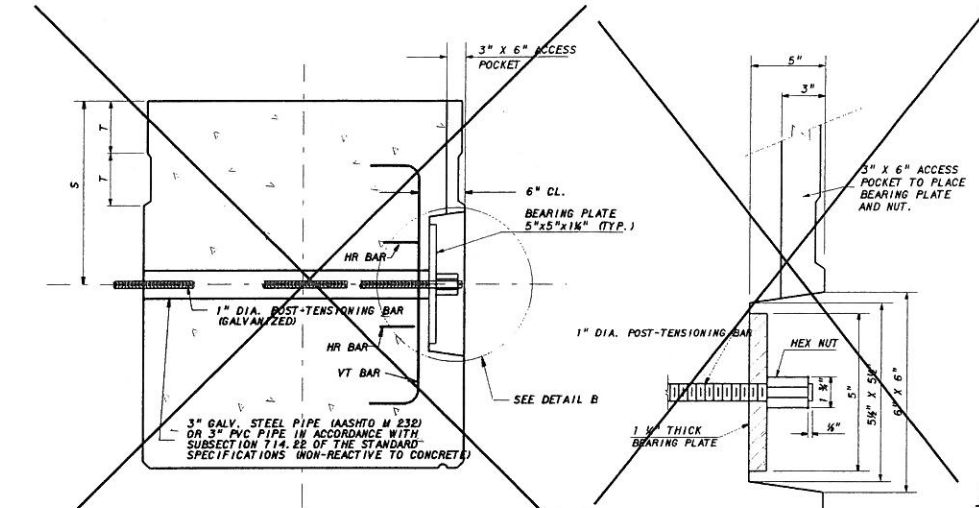

ACCESS POCKET, END POST-TENSIONING BAR (NO SCALE)

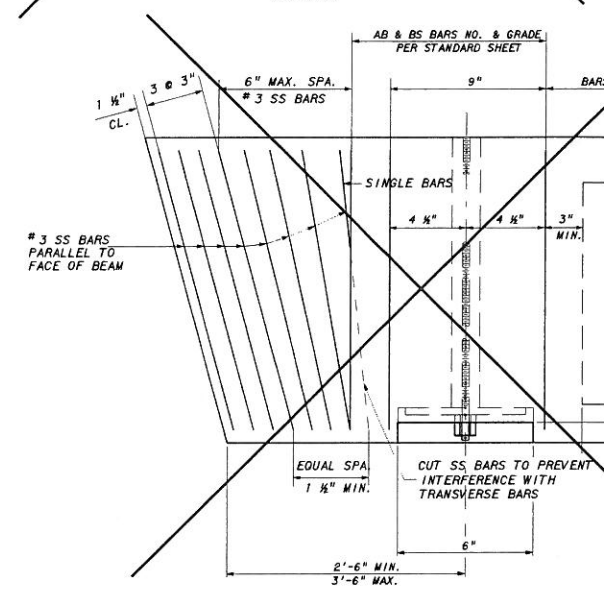

SHEAR REINFORCEMENT DETAIL @ BEAMS WITH POCKETS (NO SCALE)

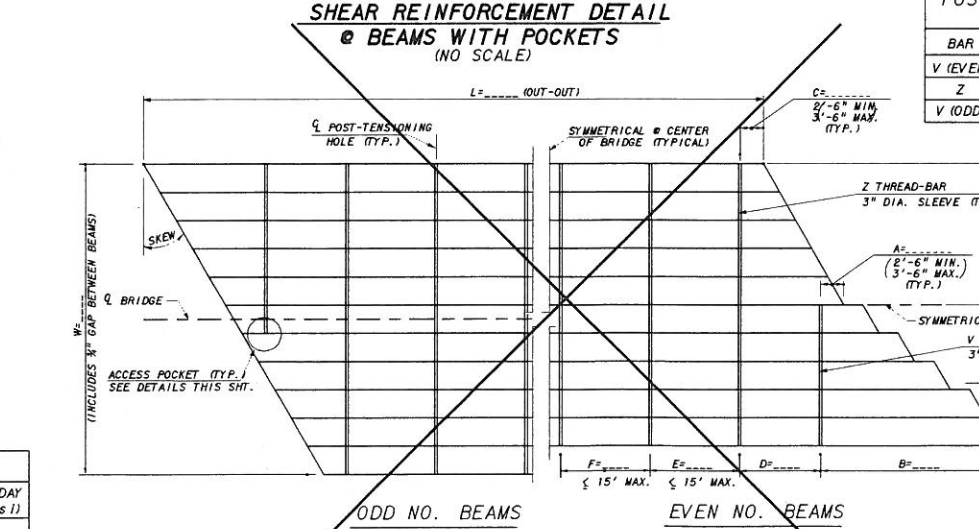

PLAN VIEW-SKEWED BRIDGE > 20° POST-TENSIONING BAR SPACING (NO SCALE)

REINFORCING DETAILS @ DIAPHRAGM (EXT. BEAM & POCKETS ONLY) (NO SCALE)

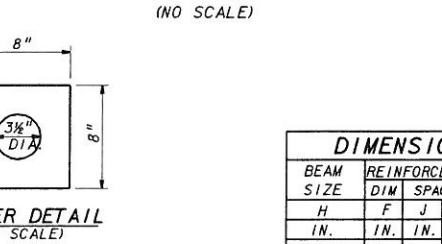

REINFORCING DETAILS @ DIAPHRAGM (EXT. BEAM & POCKETS ONLY) (NO SCALE)

DETAIL B (NO SCALE)

WASHER DETAIL (NO SCALE)

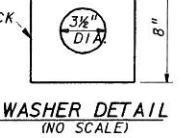

GROUT DETAILS (NO SCALE)

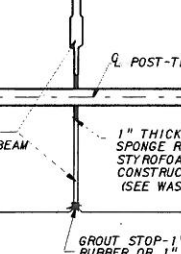

POST-TENSIONING BAR LENGTH

BAR	FORMULA	LENGTH
V (EVEN)	W/2 + 3'	
Z	W + 3'	23' - 3"
V (ODD)	W/2 + 4' - 6"	

BEAM SIZE	REINFORCEMENT DIM	BAR SPACING	BAR DIST
H	F	J	K
IN.	IN.	IN.	IN.
12	-	-	6
17	12	2 1/2	4
21	12	4 1/2	4
27	18	4 1/2	6
33	24	4 1/2	8
42	33	4 1/2	11

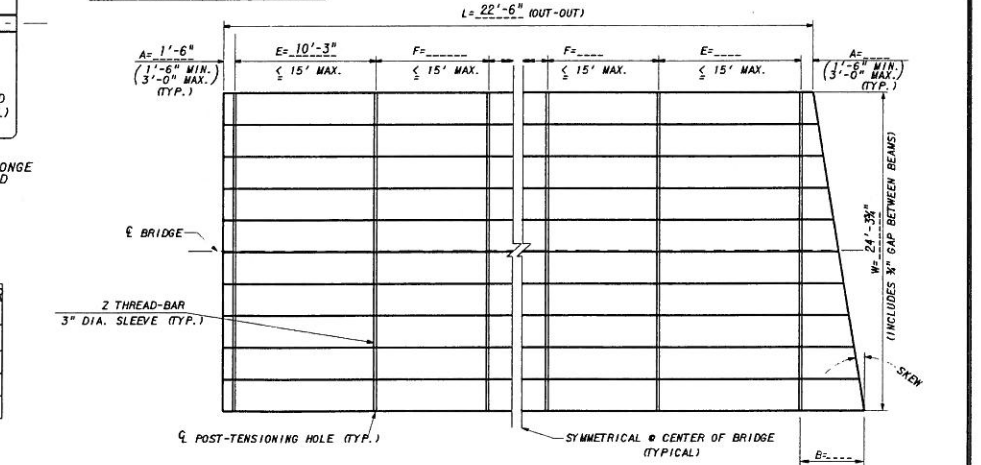

PLAN VIEW-20° SKEW OR LESS POST-TENSIONING BAR SPACING (NO SCALE)

POST-TENSIONING BAR LAYOUT SCHEDULE

SPAN	22'-0"
SKEW	0°
L	23'-6"
W	20'-3"
A	1'-6"
B	-
C	-
D	-
E	10'-3"
F	-
STEP	-

APPROVED: _____ DATE: _____

WEST VIRGINIA DEPARTMENT OF TRANSPORTATION
DIVISION OF HIGHWAYS-STRUCTURES
TRANSVERSE POST-TENSIONING DETAILS
STANDARD SHEET BR-B103

WARNING
1. DO NOT STAND IN LINE WITH THE POST-TENSIONING THREAD-BAR WHEN TENSIONING.
2. DUE TO THE DANGER ASSOCIATED WITH THE FAILURE OF THE TRANSVERSE POST-TENSIONING SYSTEM COMPONENTS, SPECIAL QUENCHED OR HARDENED COUPLERS, NUTS AND EXTENSION RODS MUST BE USED FOR REPEATED STRESSING OPERATION. REGULAR NUTS SHOULD NOT BE USED FOR THE REPEATED STRESSING OPERATION. AND SHOULD BE USED ONLY ONCE IN THE PERMANENT INSTALLATION.

THE WEST VIRGINIA DEPARTMENT OF TRANSPORTATION
DIVISION OF HIGHWAYS-STRUCTURES

PUMPHOUSE DRAINAGE STRUCTURE
OVER
DRY RUN
IN
PENDLETON COUNTY
TRANSVERSE POST-TENSIONING DETAILS
PRESTRESSED CONCRETE BEAMS

DESIGNED BY: ANK/RCK
DRAWN BY: ANK, DOW, LBF
CHECKED BY: RCK
REVIEWED BY:
DATE: 3/2013
SCALE: NONE
SHEET NO.: 9 OF 10
BRIDGE NUMBER N. A.

Z:\Des Ign Proj\61616-36-22-4.90 Pumphouse.dwg

PUBLIC ROADS DIV.	STATE DIST. NO.	PROJECT NUMBER	COUNTY	SHEET NO.	TOTAL SHTS
W.V.A.	8	36-22-4.90	PENDLETON	10	10

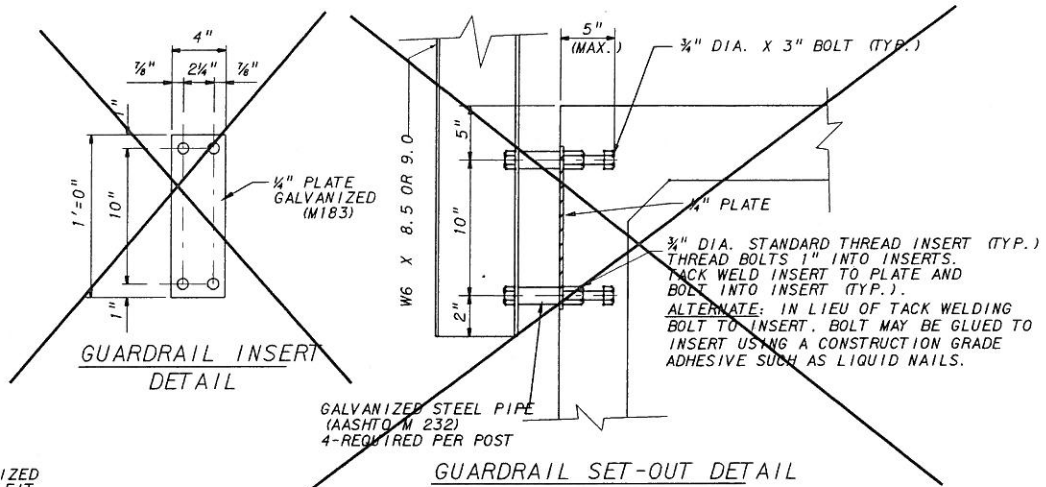

- NOTES:**
- ENTIRE ASSEMBLY IS TO BE HOT-DIPPED GALVANIZED AFTER FABRICATION. RETAP THREADS FOR PROPER FIT. ALTERNATE: IN LIEU OF HOT-DIP GALVANIZING, GUARDRAIL INSERT ASSEMBLY MAY BE ELECTRO-DEPOSITED ZINC COATED AFTER FABRICATION IN ACCORDANCE WITH ASTM B-633, TYPE 2, CLASSIFICATION NO. 25.
 - ANY DAMAGE TO GALVANIZED AREAS SHALL BE TOUCHED WITH GALVICON, OR EQUAL.
 - WHEN THE GUARDRAIL POST IS LOCATED OVER THE BRIDGE SEAT (ON 12" BEAMS ONLY) THE ANCHOR PLATE AND FOUR BOLTS SHALL BE OMITTED. INSTALL IN ACCORDANCE WITH THE "GUARDRAIL ANCHOR OVER BRIDGE SEAT" DETAIL THIS SHEET.

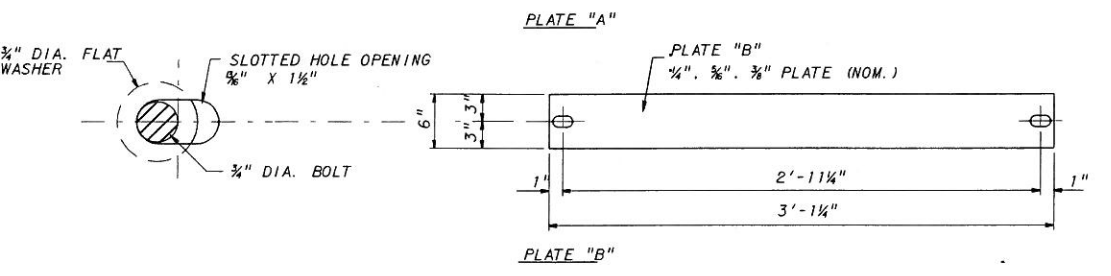
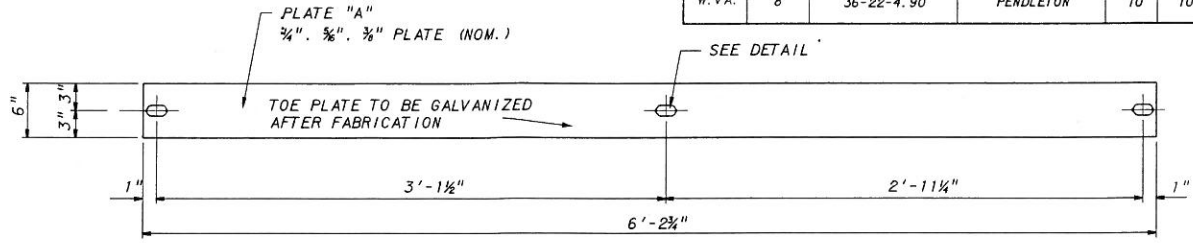
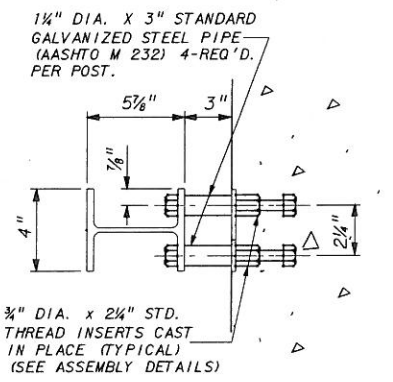

TOE PLATE DETAILS
FOR USE ON STRUCTURES WITH NO CURB

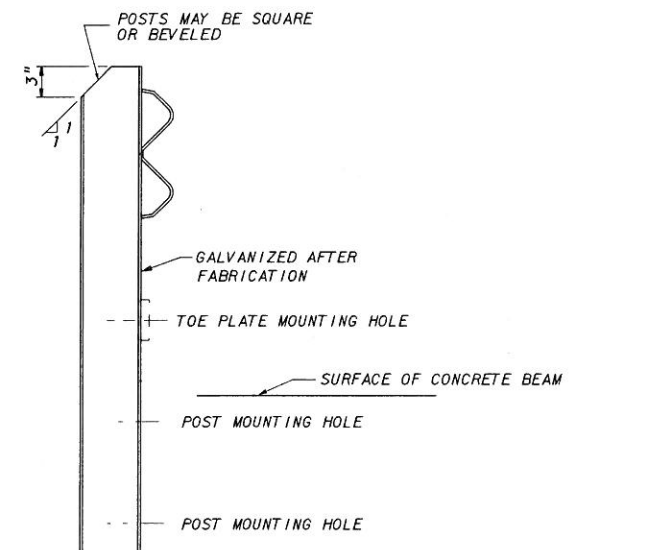
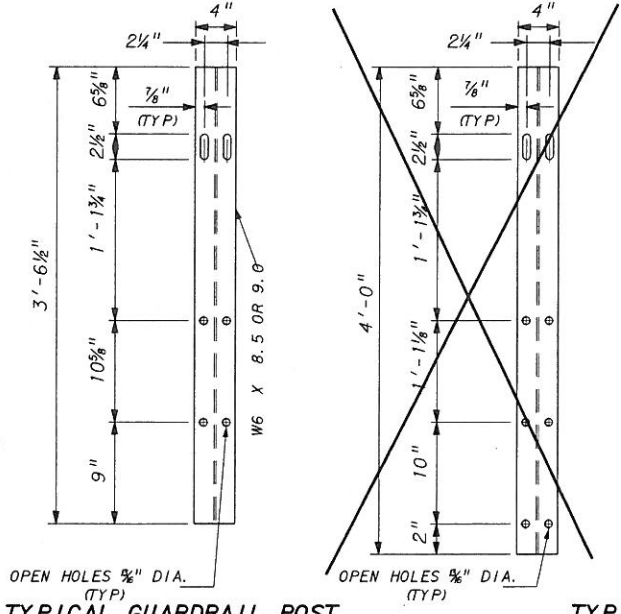
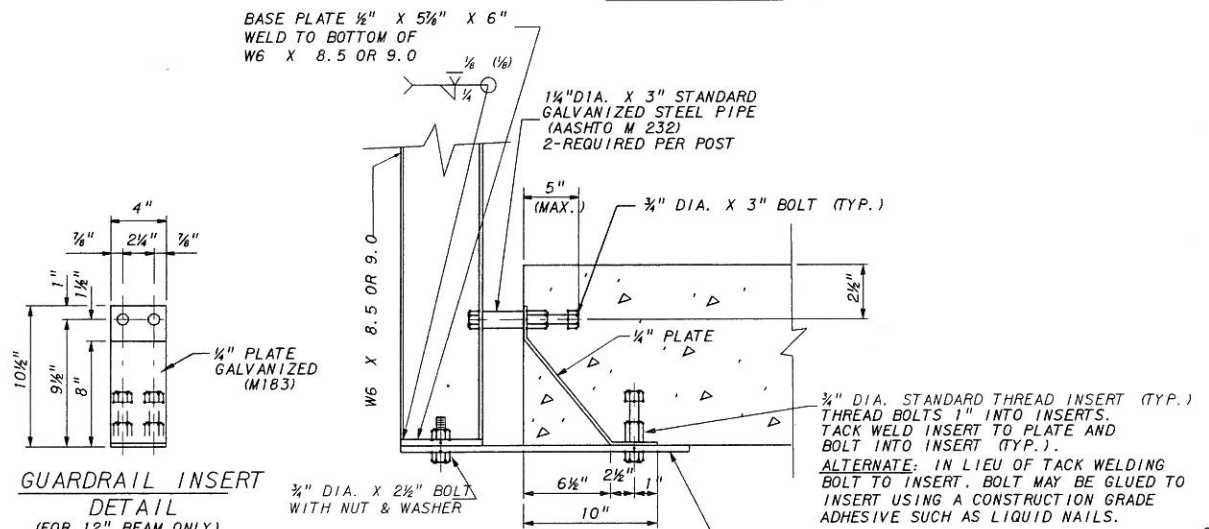

TYPICAL GUARDRAIL POST
(FOR 12" BEAM ONLY)

TYPICAL GUARDRAIL POST

NOTE:
GUARDRAIL MOUNTING SLOT (RAISE GUARDRAIL UPON COMPLETION OF FUTURE WEARING SURFACE)

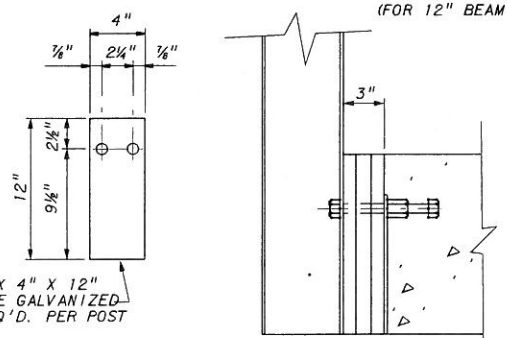

GUARDRAIL ANCHOR OVER BRIDGE SEAT
(FOR 12" BEAM ONLY)

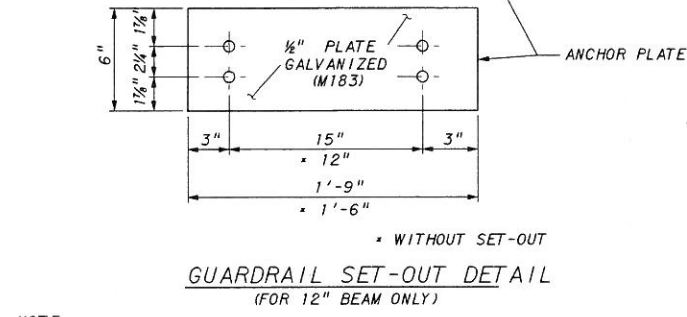

GUARDRAIL SET-OUT DETAIL
(FOR 12" BEAM ONLY)

NOTE
THIS SHEET TO BE USED WITH STANDARD SHEET BR-1 OR BR-1A, BR-S12A, BR-S12B, BR-B17A, BR-B17B, BR-B21A, BR-B21B, BR-B27A, BR-B27B, BR-B33A, BR-B33B, BR-B42A, BR-B42B, BR-B100, BR-B101, BR-B102, AND BR-B103 AS APPLICABLE.

Z:\DesIgn Proj\36-22-4.90 BR-B104.dwg

APPROVED: _____ DATE: _____
DIRECTOR, STRUCTURES DIVISION

WEST VIRGINIA DEPARTMENT OF TRANSPORTATION
DIVISION OF HIGHWAYS-STRUCTURES
PRESTRESSED CONCRETE BEAM
DESIGN & ASSEMBLY DETAILS

STANDARD SHEET BR-B104

THE WEST VIRGINIA DEPARTMENT OF TRANSPORTATION
DIVISION OF HIGHWAYS-STRUCTURES

PUMPHOUSE DRAINAGE STRUCTURE
OVER
DRY RUN
IN
PENDLETON COUNTY

PRESTRESSED CONCRETE BEAM
DESIGN & ASSEMBLY DETAILS

DESIGNED BY: _____
DRAWN BY: DWL, LBF
CHECKED BY: RCK
REVIEWED BY: _____
DATE: 3/20/13
SCALE: NONE
SHEET NO.: 10 OF 10
BRIDGE NUMBER: _____
N.A.