



State of West Virginia
 Department of Administration
 Purchasing Division
 2019 Washington Street East
 Post Office Box 50130
 Charleston, WV 25305-0130

Request for Quotation

RFQ NUMBER
PTR12031

PAGE
1

ADDRESS CORRESPONDENCE TO ATTENTION OF:
PAUL REYNOLDS 304-558-0468

VENDOR

RFQ COPY
 TYPE NAME/ADDRESS HERE

SHIP TO

DIVISION OF PUBLIC TRANSIT
 BUILDING 5, ROOM 906
 1900 KANAWHA BOULEVARD, EAST
 CHARLESTON, WV
 25305-0432 304-558-0428

DATE PRINTED	TERMS OF SALE	SHIP VIA	F.O.B.	FREIGHT TERMS
05/24/2012				

BID OPENING DATE: 06/13/2012 BID OPENING TIME 01:30PM

LINE	QUANTITY	UOP	CAT. NO.	ITEM NUMBER	UNIT PRICE	AMOUNT
0001		EA		070-93		
<p>VANS, PERSONNEL</p> <p>THE WEST VIRGINIA STATE PURCHASING DIVISION FOR THE AGENCY, THE WEST VIRGINIA DIVISION OF PUBLIC TRANSIT, IS SOLICITING BIDS TO PROVIDE 138" DUAL WHEEL CUTAWAYS WITH AIR CONDITIONING PER THE ATTACHED SPECIFICATIONS.</p> <p>EXHIBIT 2</p> <p>LIFE OF CONTRACT: THIS CONTRACT BECOMES EFFECTIVE UPON AWARD AND EXTENDS FOR A PERIOD OF ONE (1) YEAR OR UNTIL SUCH "REASONABLE TIME" THEREAFTER AS IS NECESSARY TO OBTAIN A NEW CONTRACT OR RENEW THE ORIGINAL CONTRACT. THE "REASONABLE TIME" PERIOD SHALL NOT EXCEED TWELVE (12) MONTHS. DURING THIS "REASONABLE TIME" THE VENDOR MAY TERMINATE THIS CONTRACT FOR ANY REASON UPON GIVING THE DIRECTOR OF PURCHASING THIRTY (30) DAYS WRITTEN NOTICE.</p> <p>UNLESS SPECIFIC PROVISIONS ARE STIPULATED IN THIS CONTRACT DOCUMENT BY THE STATE OF WEST VIRGINIA, ITS AGENCIES, OR POLITICAL SUBDIVISIONS, THE TERMS, CONDITIONS, AND PRICING SET FORTH HERIN ARE FIRM FOR THE LIFE OF THE CONTRACT.</p> <p>RENEWAL: THIS CONTRACT MAY BE RENEWED UPON THE MUTUAL WRITTEN CONSENT OF THE SPENDING UNIT AND VENDOR, SUBMITTED TO THE DIRECTOR OF PURCHASING THIRTY (30) DAYS PRIOR TO THE EXPIRATION DATE. SUCH RENEWAL SHALL BE IN ACCORDANCE WITH THE TERMS AND CONDITIONS OF THE</p>						

SEE REVERSE SIDE FOR TERMS AND CONDITIONS

SIGNATURE	TELEPHONE	DATE
TITLE	FEIN	ADDRESS CHANGES TO BE NOTED ABOVE

WHEN RESPONDING TO RFQ, INSERT NAME AND ADDRESS IN SPACE ABOVE LABELED 'VENDOR'

GENERAL TERMS & CONDITIONS REQUEST FOR QUOTATION (RFQ) AND REQUEST FOR PROPOSAL (RFP)

1. Awards will be made in the best interest of the State of West Virginia.
2. The State may accept or reject in part, or in whole, any bid.
3. Prior to any award, the apparent successful vendor must be properly registered with the Purchasing Division and have paid the required \$125 fee.
4. All services performed or goods delivered under State Purchase Order/Contracts are to be continued for the term of the Purchase Order/Contracts, contingent upon funds being appropriated by the Legislature or otherwise being made available. In the event funds are not appropriated or otherwise available for these services or goods this Purchase Order/Contract becomes void and of no effect after June 30.
5. Payment may only be made after the delivery and acceptance of goods or services.
6. Interest may be paid for late payment in accordance with the *West Virginia Code*.
7. Vendor preference will be granted upon written request in accordance with the *West Virginia Code*.
8. The State of West Virginia is exempt from federal and state taxes and will not pay or reimburse such taxes.
9. The Director of Purchasing may cancel any Purchase Order/Contract upon 30 days written notice to the seller.
10. The laws of the State of West Virginia and the *Legislative Rules* of the Purchasing Division shall govern the purchasing process.
11. Any reference to automatic renewal is hereby deleted. The Contract may be renewed only upon mutual written agreement of the parties.
12. **BANKRUPTCY:** In the event the vendor/contractor files for bankruptcy protection, the State may deem this contract null and void, and terminate such contract without further order.
13. **HIPAA BUSINESS ASSOCIATE ADDENDUM:** The West Virginia State Government HIPAA Business Associate Addendum (BAA), approved by the Attorney General, is available online at www.state.wv.us/admin/purchase/vrc/hipaa.html and is hereby made part of the agreement provided that the Agency meets the definition of a Cover Entity (45 CFR §160.103) and will be disclosing Protected Health Information (45 CFR §160.103) to the vendor.
14. **CONFIDENTIALITY:** The vendor agrees that he or she will not disclose to anyone, directly or indirectly, any such personally identifiable information or other confidential information gained from the agency, unless the individual who is the subject of the information consents to the disclosure in writing or the disclosure is made pursuant to the agency's policies, procedures, and rules. Vendor further agrees to comply with the Confidentiality Policies and Information Security Accountability Requirements, set forth in <http://www.state.wv.us/admin/purchase/privacy/noticeConfidentiality.pdf>.
15. **LICENSING:** Vendors must be licensed and in good standing in accordance with any and all state and local laws and requirements by any state or local agency of West Virginia, including, but not limited to, the West Virginia Secretary of State's Office, the West Virginia Tax Department, and the West Virginia Insurance Commission. The vendor must provide all necessary releases to obtain information to enable the director or spending unit to verify that the vendor is licensed and in good standing with the above entities.
16. **ANTITRUST:** In submitting a bid to any agency for the State of West Virginia, the bidder offers and agrees that if the bid is accepted the bidder will convey, sell, assign or transfer to the State of West Virginia all rights, title and interest in and to all causes of action it may now or hereafter acquire under the antitrust laws of the United States and the State of West Virginia for price fixing and/or unreasonable restraints of trade relating to the particular commodities or services purchased or acquired by the State of West Virginia. Such assignment shall be made and become effective at the time the purchasing agency tenders the initial payment to the bidder.

I certify that this bid is made without prior understanding, agreement, or connection with any corporation, firm, limited liability company, partnership, or person or entity submitting a bid for the same material, supplies, equipment or services and is in all respects fair and without collusion or fraud. I further certify that I am authorized to sign the certification on behalf of the bidder or this bid.

INSTRUCTIONS TO BIDDERS

1. Use the quotation forms provided by the Purchasing Division. Complete all sections of the quotation form.
2. Items offered must be in compliance with the specifications. Any deviation from the specifications must be clearly indicated by the bidder. Alternates offered by the bidder as **EQUAL** to the specifications must be clearly defined. A bidder offering an alternate should attach complete specifications and literature to the bid. The Purchasing Division may waive minor deviations to specifications.
3. Unit prices shall prevail in case of discrepancy. All quotations are considered F.O.B. destination unless alternate shipping terms are clearly identified in the quotation.
4. All quotations must be delivered by the bidder to the office listed below prior to the date and time of the bid opening. Failure of the bidder to deliver the quotations on time will result in bid disqualifications: Department of Administration, Purchasing Division, 2019 Washington Street East, P.O. Box 50130, Charleston, WV 25305-0130
5. Communication during the solicitation, bid, evaluation or award periods, except through the Purchasing Division, is strictly prohibited (W.Va. C.S.R. §148-1-6.6).



State of West Virginia
 Department of Administration
 Purchasing Division
 2019 Washington Street East
 Post Office Box 50130
 Charleston, WV 25305-0130

Request for Quotation

RFQ NUMBER
PTR12031

PAGE
2

ADDRESS CORRESPONDENCE TO ATTENTION OF:
**PAUL REYNOLDS
 304-558-0468**

VENDOR

RFQ COPY
 TYPE NAME/ADDRESS HERE

SHIP TO

DIVISION OF PUBLIC TRANSIT
 BUILDING 5, ROOM 906
 1900 KANAWHA BOULEVARD, EAST
 CHARLESTON, WV
 25305-0432 304-558-0428

DATE PRINTED 05/24/2012	TERMS OF SALE	SHIP VIA	F.O.B.	FREIGHT TERMS
-----------------------------------	---------------	----------	--------	---------------

BID OPENING DATE: **06/13/2012** BID OPENING TIME **01:30PM**

LINE	QUANTITY	UOP	CAT. NO.	ITEM NUMBER	UNIT PRICE	AMOUNT
<p>ORIGINAL CONTRACT AND SHALL BE LIMITED TO TWO (2) ONE (1) YEAR PERIODS.</p> <p>CANCELLATION: THE DIRECTOR OF PURCHASING RESERVES THE RIGHT TO CANCEL THIS CONTRACT IMMEDIATELY UPON WRITTEN NOTICE TO THE VENDOR IF THE COMMODITIES AND/OR SERVICE SUPPLIED ARE OF AN INFERIOR QUALITY OR DO NOT CONFORM WITH THE SPECIFICATIONS OF THE BID AND CONTRACT HEREIN.</p> <p>OPEN MARKET CLAUSE: THE DIRECTOR OF PURCHASING MAY AUTHORIZE A SPENDING UNIT TO PURCHASE ON THE OPEN MARKET, WITHOUT THE FILING OF A REQUISITION OR COST ESTIMATE, ITEMS SPECIFIED ON THIS CONTRACT FOR IMMEDIATE DELIVERY IN EMERGENCIES DUE TO UNFORESEEN CAUSES (INCLUDING BUT NOT LIMITED TO DELAYS IN TRANSPORTATION OR AN UNANTICIPATED INCREASE IN THE VOLUME OF WORK).</p> <p>QUANTITIES: QUANTITIES LISTED IN THE REQUISITION ARE APPROXIMATIONS ONLY, BASED ON ESTIMATES SUPPLIED BY THE STATE SPENDING UNIT. IT IS UNDERSTOOD AND AGREED THAT THE CONTRACT SHALL COVER THE QUANTITIES ACTUALLY ORDERED FOR DELIVERY DURING THE TERM OF CONTRACT, WHETHER MORE OR LESS THAN THE QUANTITIES SHOWN.</p> <p>ORDERING PROCEDURE: SPENDING UNIT(S) SHALL ISSUE A WRITTEN EQUIPMENT CONTRACT ORDER (FORM NUMBER WV-35) FOR COMMODITIES COVERED BY THIS CONTRACT. THE ORIGINAL WV-35 MUST BE SENT TO THE PURCHASING DIVISION OF THE DEPARTMENT OF ADMINISTRATION. AFTER APPROVAL AND ENCUMBRANCE, ONE COPY OF THE PURCHASE ORDER WILL BE RETURNED TO THE SPENDING UNIT AND ONE COPY FORWARDED TO THE VENDOR AS AUTHORIZATION FOR SHIPMENT. NO ORDER IS VALID UNLESS APPROVED AND ENCUMBERED BY THE PURCHASING DIVISION.</p> <p>BANKRUPTCY: IN THE EVENT THE VENDOR/CONTRACTOR FILES</p>						

SEE REVERSE SIDE FOR TERMS AND CONDITIONS

SIGNATURE	TELEPHONE	DATE
TITLE	FEIN	ADDRESS CHANGES TO BE NOTED ABOVE

WHEN RESPONDING TO RFQ, INSERT NAME AND ADDRESS IN SPACE ABOVE LABELED 'VENDOR'



State of West Virginia
 Department of Administration
 Purchasing Division
 2019 Washington Street East
 Post Office Box 50130
 Charleston, WV 25305-0130

Request for Quotation

RFQ NUMBER
PTR12031

PAGE
3

ADDRESS CORRESPONDENCE TO ATTENTION OF:
PAUL REYNOLDS
304-558-0468

VENDOR

RFQ COPY
 TYPE NAME/ADDRESS HERE

SHIP TO

DIVISION OF PUBLIC TRANSIT
 BUILDING 5, ROOM 906
 1900 KANAWHA BOULEVARD, EAST
 CHARLESTON, WV
 25305-0432 304-558-0428

DATE PRINTED	TERMS OF SALE	SHIP VIA	F.O.B.	FREIGHT TERMS
05/24/2012				

BID OPENING DATE: **06/13/2012** BID OPENING TIME **01:30PM**

LINE	QUANTITY	UOP	CAT. NO.	ITEM NUMBER	UNIT PRICE	AMOUNT
<p>FOR BANKRUPTCY PROTECTION, THE STATE MAY DEEM THE CONTRACT NULL AND VOID, AND TERMINATE SUCH CONTRACT WITHOUT FUTHER ORDER.</p> <p>REV. 01/17/2012</p> <p style="text-align: center;">NOTICE</p> <p>A SIGNED BID MUST BE SUBMITTED TO:</p> <p style="text-align: center;">DEPARTMENT OF ADMINISTRATION PURCHASING DIVISION BUILDING 15 2019 WASHINGTON STREET, EAST CHARLESTON, WV 25305-0130</p> <p>THE BID SHOULD CONTAIN THIS INFORMATION ON THE FACE OF THE ENVELOPE OR THE BID MAY NOT BE CONSIDERED:</p> <p>SEALED BID</p> <p>BUYER: PAUL REYNOLDS</p> <p>RFQ. NO.: PTR12031</p> <p>BID OPENING DATE: 06/13/2012</p> <p>BID OPENING TIME: 01:30 P.M.</p> <p>PLEASE PROVIDE A FAX NUMBER IN CASE IT IS NECESSARY TO CONTACT YOU REGARDING YOUR BID:</p> <p style="text-align: center;">-----</p> <p>CONTACT PERSON (PLEASE PRINT CLEARLY):</p>						

SEE REVERSE SIDE FOR TERMS AND CONDITIONS

SIGNATURE	TELEPHONE	DATE
TITLE	FEIN	ADDRESS CHANGES TO BE NOTED ABOVE

WHEN RESPONDING TO RFQ, INSERT NAME AND ADDRESS IN SPACE ABOVE LABELED 'VENDOR'



State of West Virginia
 Department of Administration
 Purchasing Division
 2019 Washington Street East
 Post Office Box 50130
 Charleston, WV 25305-0130

Request for Quotation

RFQ NUMBER
PTR12031

PAGE
4

ADDRESS CORRESPONDENCE TO ATTENTION OF:
PAUL REYNOLDS
304-558-0468

RFQ COPY
 TYPE NAME/ADDRESS HERE

VENDOR

SHIP TO

DIVISION OF PUBLIC TRANSIT
 BUILDING 5, ROOM 906
 1900 KANAWHA BOULEVARD, EAST
 CHARLESTON, WV
 25305-0432 304-558-0428

DATE PRINTED	TERMS OF SALE	SHIP VIA	F.O.B.	FREIGHT TERMS
05/24/2012				

BID OPENING DATE: **06/13/2012** BID OPENING TIME **01:30PM**

LINE	QUANTITY	UOP	CAT. NO.	ITEM NUMBER	UNIT PRICE	AMOUNT

ANY INDIVIDUAL SIGNING THIS BID IS CERTIFYING THAT: (1) HE OR SHE IS AUTHORIZED BY THE BIDDER TO EXECUTE THE BID OR ANY DOCUMENTS RELATED THERETO ON BEHALF OF THE BIDDER, (2) THAT HE OR SHE IS AUTHORIZED TO BIND THE BIDDER IN A CONTRACTUAL RELATIONSHIP, AND (3) THAT THE BIDDER HAS PROPERLY REGISTERED WITH ANY STATE AGENCIES THAT MAY REQUIRE REGISTRATION.						
***** THIS IS THE END OF RFQ PTR12031 ***** TOTAL:						_____

SEE REVERSE SIDE FOR TERMS AND CONDITIONS

SIGNATURE	TELEPHONE	DATE
-----------	-----------	------

TITLE	FEIN	ADDRESS CHANGES TO BE NOTED ABOVE
-------	------	-----------------------------------

WHEN RESPONDING TO RFQ, INSERT NAME AND ADDRESS IN SPACE ABOVE LABELED 'VENDOR'

PART 1 GENERAL CONDITIONS

1.0 INTENT OF RFQ

It is the intent of this Request for Quotation (RFQ) to require the Vendor to deliver a complete new vehicle of the type prescribed, ready for operation.

2.0 PRICE FOR A COMPLETE VEHICLE

- A. The price quoted in any proposal submitted shall include all labor, materials, tools, warranties, equipment, and other costs necessary to complete the manufacture and delivery of the vehicle. Any items omitted from the specifications which are clearly necessary for the completion and operation of such equipment and its appurtenances shall be considered a portion of such equipment, although not directly stated or covered in these specifications.

Notwithstanding the provision of drawings, technical specifications, or other data by the Division of Public Transit, the Vendor shall have the responsibility of supplying all parts and details required to make the vehicle complete and ready for service even though such details may not be specifically mentioned in the drawings and specifications. Fareboxes, radios, and other items that are installed by the Recipient Agency shall not be the responsibility of the Vendor unless they are included in this contract.

- B. The Purchasing Division of the Department of Administration in conjunction with the Division of Public Transit and the vendor shall mutually agree when it is necessary to make changes in, additions to, or deductions from the work to be performed or the material to be furnished, pursuant to the contract. Any changes which affect the contract price shall be in writing and require the approval of the Division of Public Transit and the Purchasing Division.
- C. **All prices are to be quoted in whole dollars** and submitted on Bid Form. Bid will be awarded to responsive vendor with lowest bid price on a base vehicle with 2 wheelchair spaces including delivery charges.
- D. Unit and extended prices, delivery charges and options should all be itemized.

3.0 POSSIBLE RENEWAL

- A. This Contract may be renewed upon the mutual written consent of the Division of Public Transit and the successful bidder. Such a request for renewal would be submitted to the Director of the WV Purchasing Division thirty (30) days prior to the expiration date of the awarded Contract. Such renewal shall be in accordance with the terms and conditions of the original Contract and shall be limited to two (2) one (1) year periods.
- B. Quantities listed in the RFQ are approximations only, based on estimates supplied by the Division of Public Transit. The awarded Contract shall cover the quantities actually ordered for delivery during the term of the Contract.
- C. Additional agencies could purchase from any awarded contract resulting from this RFQ. Specified deliverables would be as originally advertised, competed, evaluated and awarded including the base and option quantities.

4.0 DELIVERY AND ACCEPTANCE

- A. Vendors shall specify approximate delivery date(s) when submitting bids. Delivery of the vehicle should be completed within 150 days after receipt of executed contract documents.

If the delivery is delayed, for any reason, the request for extension must be made in writing to the Division of Public Transit.

The request for extension must be received by the Division of Public Transit no less than 10 days prior to the originally planned vehicle delivery date and must include detailed justification for the length of the time

extension. In the event that the Vendor fails to give timely written notice of any delay, in delivery, it is agreed that liquidated damages will be assessed, **NOT AS A PENALTY**, in the amount of \$50.00 per calendar day, per unit, beyond the required delivery date.

- B. Vendor shall make arrangements through the Division of Public Transit for delivery of the vehicles to **Division of Public Transit c/o Kanawha Valley Regional Transportation Authority, 1550 4th Avenue, Charleston, WV**. Delivery will be accepted Monday through Friday, between 9 a.m. and 2 p.m. exclusive of State holidays.

Any delay in delivery resulting from the common carrier's operations, accidents, or mechanical failures en route, shall be construed as a cause beyond the Vendor's control; however, the Vendor shall have the responsibility of releasing the vehicle to the common carrier in time to reach the delivery site under normal delivery conditions.

- C. In case the delivery of the complete vehicle shall be necessarily delayed because of strike, injunction, civil disturbance, government controls, or by reason of any cause or circumstances beyond the control of the Vendor, as detailed in writing by the Vendor, the term of completion of delivery shall be extended by a number of days to be determined in each instance by mutual agreement of the Division of Public Transit and Vendor.
- D. If the vehicle is delivered over-the-road, a written report shall be submitted by the driver to the Division of Public Transit listing all incidents and unusual vehicle performance during the trip.

Should any service or repair be required during delivery, a comprehensive report shall be submitted to the Director of the Division of Public Transit describing the nature of the service or repair and the cause.

- E. Prior to acceptance, the Vendor shall have total risk of loss of the vehicle, including any damage sustained during the Vendor's driveway operation. Drivers shall keep a maintenance log enroute and it shall be delivered to the Division of Public Transit with the vehicle.
- F. Vendor shall have 10 working days to complete a vehicle for conditional acceptance once the vehicle is received at Kanawha Valley Regional Transportation Authority. After 10 working days, the Vendor shall be responsible for paying the storage fee invoiced at a per day rate of currently \$10. The per-day rate shall be deducted from payment of the final 10% of the vehicle cost.

4.1 Summary of Items to be Provided Upon Delivery

The following items must be furnished by the successful Vendor upon delivery of the vehicle:

- 4.1.1 All warranty verification vouchers, certificates or coupons.
- 4.1.2 Successful Vendor shall furnish each transit system: two (2) complete parts books and two (2) copies of maintenance manuals for each model year vehicle, including wiring schematics of auxiliary circuits, and all other necessary prints for the maintenance of the vehicle and (1) complete set of OEM Operations manual per transit system. All other orders, to other than transit systems, the successful Vendor shall supply (1) one copy of each mentioned per vehicle.
- 4.1.3 Drawings showing wiring schematics of auxiliary circuits, which would not be included in the standard vehicle maintenance manual.
- 4.1.4 Completely filled fuel tank or tanks.
- 4.1.5 Protection to 20° F below zero with permanent type antifreeze.
- 4.1.6 A vehicle(s) free of dealer signs and emblems.
- 4.1.7 Assurance of compliance with manufacturer's pre-delivery service.

- 4.1.8 A vehicle(s) which is clean, (If delivery of the vehicle occurs during the winter months of October through March, the vehicle shall be washed directly prior to delivery at Kanawha Valley Regional Transportation Authority to ensure that the vehicle is free of dirt and salt deposits) lubricated, serviced and ready for immediate service.
- 4.1.9 Operation, maintenance and warranty information for any add on equipment will be provided upon delivery if available to the Vendor.
- 4.1.10 Original vehicle chassis manufacturer's factory sticker itemizing equipment on the vehicle.
- 4.1.11 A certified weight slip showing front and drive axle weights for the vehicle at its curb weight as defined in Part 2 - Technical Specifications.
- 4.1.12 Vehicle shall comply with and conform to the State of West Virginia Motor Vehicle Inspection Law and shall have the current inspection sticker attached to the windshield.

4.2 Pre-Delivery Tests and Inspections

The pre-delivery tests and inspections shall be performed at or near the Vendor's plant in accordance with the procedures outlined in Part 4, "Quality Assurance", and shall be witnessed by the Vendor's resident inspector and/or by a representative of the Division of Public Transit. The vehicles shall be tested and inspected to determine whether they comply with the technical specifications in general and in particular with the quality assurance provisions. When the vehicles pass these tests and inspections, the resident inspector shall authorize release of the vehicles. The Division of Public Transit is under no obligation to perform the pre-delivery tests and inspections; however, this does not relieve the Vendor from the responsibility of adhering to these specifications.

4.3 Acceptance of Vehicle(s)

Within fifteen (15) calendar days after arrival at the designated point of delivery, the vehicle shall undergo the Division of Public Transit acceptance test. If the vehicle passes these tests, conditional acceptance of the vehicle by the Division of Public Transit occurs on the fifteenth day after delivery. Acceptance may occur earlier if the Division of Public Transit notifies the Vendor of early acceptance. If the vehicle fails these tests, it shall not be accepted until the repairs have been made.

4.4 Repairs After Non-Acceptance

The Division of Public Transit may require the Vendor, or its designated representative, to perform the repairs after non-acceptance or the work may be done by the Recipient Agency's personnel with reimbursement by the Vendor.

4.4.1 Repairs By Vendor

If the Recipient Agency requires the Vendor to perform repairs after non-acceptance of the vehicle, Vendor's representative must begin work within five (5) working days after receiving notifications from the Recipient Agency of failure of acceptance tests. The Recipient Agency shall make the vehicle available to complete repairs timely with the Vendor's repair schedule.

The Vendor shall provide, at its own expense, all spare parts, tools, and space required to complete the repairs. At the Recipient Agency's option, the Vendor may be required to remove the vehicle from the Recipient Agency's property. The repair procedure must be diligently pursued by the Vendor's representatives, and the Vendor shall assume risk of loss while the vehicle is under its control.

4.4.2 Repairs By Recipient Agency

- a) Parts Used. If the Recipient Agency decides to perform the repairs after non-acceptance of the vehicle, it shall correct or repair the defect and any related defects using Vendor specified parts available from its own stock or those supplied by the Vendor specifically for this repair.

Monthly, or at a period to be mutually agreed upon, reports of all repairs covered by this procedure shall be submitted by the Recipient Agency to the Vendor for reimbursement or replacement of parts. The Vendor shall provide forms for these reports.

- b) Vendor Supplied Parts. If the Vendor supplies parts for repairs being performed by the Recipient Agency, after non-acceptance of the vehicle, these parts shall be shipped prepaid to the Recipient Agency from any source selected by the Vendor within ten (10) working days after receipt of the request for said parts, provided said parts are available for shipment.
- c) Return of Defective Components. The Vendor may request that parts covered by this provision be returned to the manufacturing plant. The total cost for this action shall be paid by the Vendor.
- d) Reimbursement For Labor. The Recipient Agency shall be reimbursed by the Vendor for labor. The amount shall be determined by multiplying the number of actual man-hours" straight wage rate plus 53 percent fringe benefits, plus the cost of towing in the vehicle if such action was necessary. These wage and fringe benefit rates shall not exceed the rates in effect in the Recipient Agency's service garage at the time the defect correction is made.
- e) Reimbursement For Parts. The Recipient Agency shall be reimbursed by the Vendor for defective parts that must be replaced to correct the defect. The reimbursement shall include taxes where applicable and 10 percent handling cost.

5.0 TITLE

Adequate documents for securing the vehicle in the name of the State of West Virginia/Division of Public Transit shall be provided to the Division of Public Transit at least 10 working days prior to the delivery of each vehicle. The Vendor warrants that the title shall pass to the State of West Virginia/Division of Public Transit free and clear of all liens, mortgages and encumbrances, financing statements, security agreements, claims and demands of any character.

According to WV State Code §SA-3-4(8), vendor agrees that liquidated damages shall be imposed at the rate of \$10 per calendar day for failure to provide the titling documentation at the time of vehicle delivery. This clause shall in no way be considered exclusive and shall not limit the State or agency's right to pursue any other additional remedy to which the State or agency may have legal cause for action including further damages against the vendor.

6.0 PAYMENT TO VENDOR

- A. Payment of 90% of the total cost shall be paid upon conditional acceptance of the vehicle.
- B. Conditional acceptance of the vehicles by the Division of Public Transit shall be made upon completion of inspection by the Division of Public Transit under Section 4.3 of this Part 1.
- C. Under the conditional acceptance of the vehicles provided, the Division of Public Transit shall retain 10% of the total cost per vehicle until all vehicles provided have been in actual service for 30 days.
- D. In the event any vehicle is found to be unacceptable during the 30 day period of conditional acceptance, the Division of Public Transit shall furnish to the Vendor, in writing, a letter of non-acceptance detailing any and all deficiencies.
- E. Final acceptance of each vehicle shall be made by the Division of Public Transit in writing upon completion of the period of conditional acceptance and/or after any and all deficiencies have been corrected.
- F. Final acceptance shall be made on each individual vehicle provided. (Some vehicles may be accepted, while acceptance of others remain pending.)
- G. Final acceptance of each vehicle shall be provided in writing by the Director of the Division of Public Transit or his/her authorized representative.

- H. All warranties as described in this contract shall begin with the first day after the date of final acceptance of each vehicle. **Vendor shall furnish Notification of Delayed Delivery Date or In-Transit Mileage Accumulation Forms for completion by the Division of Public Transit upon acceptance of the vehicle.**
- I. Prompt Payment The prime Vendor agrees to pay each sub-contractor under this prime contract for satisfactory performance of its contract no later than 15 days from the receipt of each payment the prime Vendor receives from the Division of Public Transit. The Vendor agrees further to return retainage payments to each subcontractor within 15 days after the subcontractor's work is satisfactorily completed. Any delay or postponement of payment from the above referenced time frame may occur only for good cause following written approval of the Division of Public Transit. This clause applies to both DBE and non-DBE subcontractors.
- J. When submitting invoices for payment to the Division of Public Transit, the Vendor shall be required to provide an original typed invoice. The following items shall appear on the invoice:
- 1) Vendor's Federal Employee Identification Number (FEIN)
 - 2) Purchase Order Number
 - 3) Invoice should reflect the base vehicle cost and any applicable options with unit cost. **NOTE: Two invoices shall be submitted for each vehicle, one for 90% and one for 10%.**
 - 4) Submit all invoices to:
 Division of Public Transit
 Building 5, Room 906
 1900 Kanawha Blvd., East
 Charleston, West Virginia 25305-0432

7.0 SERVICE AND PARTS

The Vendor shall state on **Bid Form #1** the representative(s) responsible for assisting the Recipient Agency (ies), as well as the location of the nearest distribution center(s) which shall furnish a complete supply of parts and components for the repair and maintenance of the vehicles to be supplied.

7.1 Specified Parts and "Approved Equals"

7.1.1 All parts shall be new and in no case will used (except for testing), reconditioned, or obsolete parts be accepted. Vehicles shall have identical units, accessories, and construction.

7.1.2 In all cases, materials shall be furnished as specified. Where brand names or specific items or processes are used in the specifications, consider the term "approved equal" to follow. However, a request for approval for any proposed substitution or "approved equal" shall be included in writing under the terms stated in Section 8.2 of Part I.

The Vendor may be required to supply the purchaser with performance data, samples, and special guarantees as a condition of acceptance of any proposed alternates.

7.1.3 The Division of Public Transit shall have the power to reject any material furnished or work performed under the contract which does not conform to these specifications and contract.

7.2 Materials and Workmanship

7.2.1 Vendor shall incorporate in the proposed vehicle(s) the latest technological achievements consistent to achieving maximum service life and superior attractiveness of appearance.

7.2.2 Vehicle(s) shall be delivered in new, first-class condition, complete and ready for operation on the street and the Vendor shall assume all responsibility and liability incident to said delivery.

7.2.3 All materials used in the construction of vehicle(s) and in all its parts and accessories shall conform to A.S.T.M., S.A.E., or similar associations published standards, and be of top quality.

7.2.4 The vehicle(s) shall be built with suitable and easily accessible compartments provided for all apparatus, sound deadening insulation, wherever needed, and all operating devices so mounted as to reduce and keep all noise and vibration to an absolute minimum.

7.2.5 Vendor shall assume responsibility for all material and accessories used in vehicle(s) and their proper installation and their warranty, whether the same is manufactured by the Vendor or purchased ready-made from a source outside the Vendor's company.

7.3 Spare Parts

The Vendor shall guarantee the availability of replacement parts for these vehicles for at least a seven (7) year period after the date of acceptance. Spare parts shall be interchangeable with the original equipment and shall be manufactured in accordance with the quality assurance provisions of this contract.

7.4 Engineers

The Vendor shall, at its own expense, have a competent engineering representative(s) available on request to assist the Recipient Agency's (ies') staff in the solution of engineering or design problems within the scope of the specifications that may arise during the warranty period.

7.5 Documents

The Vendor shall provide current maintenance manuals, current parts manuals, and standard operator manuals, for each agency or authority, to the Division of Public Transit as part of this contract. The Vendor shall keep maintenance manuals available for a period of ten (10) years after the date of acceptance of the vehicles procured under this contract. The Vendor shall also keep parts books up-to-date for a period of ten (10) years. The supplied maintenance and operator's manuals shall incorporate all equipment ordered on the vehicles covered by this procurement.

8.0 BID REQUIREMENTS

All bids must remain in effect for 120 days from the date that bids are opened.

8.1 Qualifications for Award

Award of the contract shall be made to the Vendor quoting the lowest base vehicle with two wheelchair spaces bid price, including delivery charges, as described on Bid Form, provided the bid is responsive in all respects to these procurement requirements. The Vendor must be a person, firm or corporation that:

Has in operation, a manufacturing plant adequate to assure delivery of all equipment within the time specified under the contract.

Has adequate engineering and service personnel, or has the capability to have such personnel, to satisfy any engineering or service problems that may arise during the warranty period.

Has similar vehicles in operation in comparable service for a minimum of one (1) year. The Vendor may be required to furnish a customer list indicating the number of units and dates in service during the bid evaluation period in addition to the requirements under 8.5.9 of this part of the specifications.

In lieu of this requirement, certified results of a shaker test may be requested by the Division of Public Transit to prove the proposed vehicles to be capable of operating the service contemplated for these vehicles.

Has the necessary facilities and financial resources to complete the contract in a satisfactory manner within a required time. The Division of Public Transit shall have the right to conduct a pre-award survey of each Vendor.

Has complete and accurate maintenance, parts and operator's manuals.

8.2 Requests for Approved Equals or Clarifications

Since this RFQ has been out to bid before, no clarifications or approved equals period will be held. Please see Bid Form 7 for further instruction.

8.3 Summary of Items to be Supplied With Bid

By submitting the items in 8.3.1 and 8.3.2 below, the Vendor certifies that it will comply with all requirements of this RFQ and related addenda.

8.3.1 All forms included under Part 5 (Bid Forms) must be properly completed and furnished by the Vendor as part of the bid. Failure to submit any of these forms shall disqualify the bid.

8.3.2 Technical and other data as required under 8.5, "Pre-Award Review".

8.4 Certifications

Vendor shall certify on **Bid Form #2 and #5** that the vehicles offered comply with the following:

8.4.1 Air and Noise Pollution Certification

The Vendor bidding on these specifications shall be required to certify in writing that the vehicle(s) shall comply with the air pollution criteria established by the Environmental Protection Agency of the United States Government.

8.4.2 Safety Certification

The Vendor shall furnish written certification that the vehicle(s) shall comply with the Federal Motor Vehicle Safety Standards as established by the U. S. Department of Transportation and with requirements of the laws of the State of West Virginia, all as in effect at the time of manufacture, as to lighting equipment and all warning, operating and safety devices.

8.5 Pre-Award Review

The Vendor shall submit the following items within the bid and any further items if requested by the Division of Public Transit. Failure to submit items will result in disqualification of the bid.

8.5.1 Complete mechanical description of vehicle, its construction and equipment including manufacturer's model name and/or number. Equipment to be described shall include the wheelchair lift, air conditioner, flip-up seat, and wheelchair securement system, if these items are specified herein.

8.5.2 Proposed interior floor plan, showing detailed dimensions including the location of the wheelchair securement system and stanchions if specified.

8.5.3 Curb weight (empty weight) and gross vehicle weight rating (GVWR) of vehicle.

8.5.4 Samples or paint charts of available exterior paint colors.

8.5.5 Description of the warranties the Vendor proposes to furnish for the vehicle and for required ancillary equipment, including a listing of sites where warranty work will be performed.

- 8.5.6 The location of the nearest depot which will furnish a complete supply of parts and components for the repair and maintenance of the vehicle to be supplied.
- 8.5.7 Description of the undercoating/rustproofing system, including warranty to be provided.
- 8.5.8 Identification of the specific location of the place of assembly in the case of a bus or the place of a conversion in the case of a converted van. If the location changes, the Vendor must notify the Division of Public Transit, in which case the Division of Public Transit reserves the right to perform an inspection similar to the pre-award inspection identified. If the results of the inspection are unsatisfactory, the contract may be terminated by the Division of Public Transit.
- 8.5.9 A list of five users' names, addresses, and telephone numbers who have been provided similar equipment by the Vendor. If the Vendor has not provided similar equipment, the Division of Public Transit reserves the right to determine the acceptability of the equipment proposed by the Vendor.

8.6 Disadvantaged Business Enterprise

- 8.6.1 All U. S. Department of Transportation, Federal Transit Administration (FTA) assisted contracts between FTA, the Division of Public Transit, and any Vendor shall include the following language:

POLICY. It is the policy of the Department of Transportation that Disadvantaged Business Enterprises as defined in 49 CFR Part 26 shall have the maximum opportunity to participate in the performance of contracts financed in whole or in part with federal funds under this agreement. Consequently, the DBE requirements of 49 CFR Part 26 apply to the agreement.

DBE OBLIGATION. The recipient or its Vendor agrees to ensure that Disadvantaged Business Enterprises as defined in 49 CFR Part 26 have the maximum opportunity to participate in the performance of contracts and subcontracts financed in whole or in part with federal funds provided under this agreement. In this regard, all recipients or Vendors shall take all necessary and reasonable steps in accordance with 49 CFR Part 26 to ensure that Disadvantaged Business Enterprises have the maximum opportunity to compete for and perform contracts. Recipients and their Vendors shall not discriminate on the basis of race, color, national origin, religion, sex, age or physical handicap in the award and performance of DOT-assisted contracts.

- 8.6.2 The manufacturer of transit vehicles shall certify that it has complied with the requirements of 49 CFR Part 26 (March 4, 1999), Section 26.49, "Transit Vehicle Manufacturers." This certification shall be submitted with responses to this solicitation on **Bid Form #3**.
- 8.6.3 The Vendor shall make good faith efforts to replace a Disadvantaged Business Enterprise subcontractor, that is unable to perform, with another Disadvantaged Business Enterprise subcontractor.
- 8.6.4 Where the Vendor is found to have failed to exert sufficient reasonable and good faith efforts to involve DBE's in the work provided, the Division of Public Transit may declare the Vendor non-compliant and in breach of contract.
- 8.6.5 The Vendor will keep records and documents for a reasonable time following performance of this contract to indicate compliance with WV Department of Transportation, Division of Public Transit DBE Program. These records and documents will be made available at reasonable times and places for inspection by any authorized representative of the WV Department of Transportation, Division of Public Transit and will be submitted to the WV Department of Transportation, Division of Public Transit upon request.
- 8.6.6 The Vendor or subcontractor shall not discriminate on the basis of race, color, national

origin, or sex in the performance of this contract. The Vendor shall carry out applicable requirements of 49 CFR Part 26 in the award and administration of DOT assisted contracts. Failure by the Vendor to carry out these requirements is a material breach of this contract, which may result in the termination of this contract or such other remedy as the WV Department of Transportation, Division of Public Transit deems appropriate.

8.7 Fly America

The Vendor agrees to comply with 49 U.S.C. 40118 (the "Fly America" Act) in accordance with General Services Administration's regulations at 41 CFR Part 301-10, which provide that recipients and subrecipients of Federal funds and their vendors are required to use U.S. Flag air carriers for U.S. Government-financed international air travel and transportation of their personal effects or property, to the extent such service is available, unless travel by foreign air carrier is a matter of necessity, as defined by the Fly America Act. The Vendor shall submit, if a foreign air carrier was used, an appropriate certification or memorandum adequately explaining why service by a U.S. Flag air carrier was not available or why it was necessary to use a foreign air carrier and

shall, in any event, provide a certificate of compliance with the Fly America requirements. The Vendor agrees to include the requirements of this section in all subcontracts that may involve international air transportation.

8.8 Prohibited Interest

No employee, officer, board member, agent or their family members of the Division of Public Transit may participate in the selection, award, or administration of a Contract supported by Federal funds if a real or apparent conflict of interest is involved. Such a conflict could arise when any of the parties mentioned above have a financial or other interest in the Vendor selected for the Contract.

8.9 Civil Rights Requirements

In connection with the execution of this contract, the following requirements will apply:

- (1) Nondiscrimination. In accordance with Title VI of the Civil Rights Act of 1964, as amended, 42 U.S.C. §§ 2000d, *et seq.*, Section 303 of the Age Discrimination Act of 1974, as amended, 42 U.S.C. § 6101, *et seq.*, Section 202 of the Americans With Disabilities Act of 1990, 42 U.S.C. § 12101, *et seq.*, and Federal transit law at 49 U.S.C. § 5332, the Vendor agrees that it will not discriminate against any employee or applicant for employment because of race, color, creed, national origin, sex, age or disability. In addition, the Vendor agrees to comply with applicable Federal implementing regulations and other implementing requirements FTA may issue.
- (2) Equal Employment Opportunity. The following equal employment opportunity requirements apply to the underlying contract:
 - (a) Race, Color, Creed, National Origin, Sex. In accordance with Title VII of the Civil Rights Act of 1964, as amended, 42 U.S.C. § 2000 e, and Federal transit laws at 49 U.S.C. § 5332, the Vendor agrees to comply with all applicable equal employment opportunity requirements of U.S. Department of Labor (U.S. DOL) regulations, "Office of Federal Contract Compliance Programs, Equal Employment Opportunity, Department of Labor," 41 C.F.R. Parts 60 *et seq.*, (which implement Executive Order No. 11246, "Equal Employment Opportunity," as amended by Executive Order No. 11375, "Amending Executive Order 11246 Relating to Equal Employment Opportunity," 42 U.S.C. § 2000e note), and with any applicable Federal statutes, executive orders, regulations, and Federal policies that may in the future affect construction activities undertaken in the course of the Project. The Vendor agrees to take affirmative action to ensure that applicants are employed, and that employees are treated during their employment, without regard to their race, color, creed, national origin, sex, disability or age. Such action shall include,

but not be limited to, the following: employment, upgrading, demotion or transfer, recruitment or recruitment advertising, layoff or termination; rates of pay or other forms of compensation; and selection for training, including apprenticeship. In addition, the Vendor agrees to comply with any implementing requirements FTA may issue.

- (b) Age. In accordance with Section 4 of the Age Discrimination in Employment Act of 1967, as amended, 42 U.S.C. §§ 623 and Federal transit law at 49 U.S.C. § 5332, the Vendor agrees to refrain from discrimination against present and prospective employees for reason of age. In addition, the Vendor agrees to comply with any implementing requirements FTA may issue.
- (c) Disabilities. In accordance with Section 102 of the Americans With Disabilities Act, as amended, 42 U.S.C. § 12112, the Vendor agrees that it will comply with the

requirements of U.S. Equal Employment Opportunity Commission, "Regulations to Implement the Equal Employment Provisions of the Americans With Disabilities

Act," 29 CFR, Part 1630, pertaining to employment of persons with disabilities. In addition, the Vendor agrees to comply with any implementing requirements FTA may issue.

- (3) The Vendor also agrees to include these requirements in each subcontract financed in whole or in part with Federal assistance provided by FTA, modified only if necessary to identify the affected parties.

8.10 Bus Testing

The Vendor agrees to comply with 49 U.S.C. § 5318(e) and FTA's implementing regulation at 49 CFR Part 665 and shall perform the following:

- (1) A manufacturer of a new bus model or a bus produced with a major change in components or configuration shall provide a copy of the final test report to the Division of Public Transit at a point in the procurement process specified by the Division of Public Transit which will be prior to the Division of Public Transit's final acceptance of the first vehicle.
- (2) A manufacturer who releases a report under paragraph 1 above shall provide notice to the operator of the testing facility that the report is available to the public.
- (3) If the manufacturer represents that the vehicle was previously tested, the vehicle being sold should have the identical configuration and major components as the vehicle in the test report, which must be provided to the Division of Public Transit prior to the Division's final acceptance of the first vehicle. If the configuration or components are not identical, the manufacturer shall provide a description of the change and the manufacturer's basis for concluding that it is not a major change requiring additional testing.
- (4) If the manufacturer represents that the vehicle is "grandfathered" (has been used in mass transit service in the United States before October 1, 1988, and is currently being produced without a major change in configuration or components), the manufacturer shall provide the name and address of the recipient of such a vehicle and the details of that vehicle's configuration and major components.
- (5) Any bidder or offerer must submit to the Division of Public Transit FTA's Bus Testing Requirements Certification on **Bid Form #8**. Bids or offers that are not accompanied by a completed certification must be rejected as non-responsive. **A copy of the bus testing report should be included with the bid.** This requirement does not apply to lower tier subcontractors.

8.11 Buy America Certification

Vendor agrees to comply with 49 U.S.C. 5323(j) and 49 CFR Part 661, which provide that Federal funds may not be obligated unless steel, iron, and manufactured products used in FTA-funded projects are produced in the United States, unless a waiver has been granted by FTA or the product is subject to a general waiver. General waivers are listed in 49 CFR 661.7 and include, microcomputer equipment, software, and small purchases (currently less than \$100,000) made with capital, operating, or planning funds. Separate requirements for rolling stock are set out at 49 CFR 661.11. Rolling stock not subject to a general waiver must be manufactured in the United States and have a 60 percent domestic content.

A bidder or offerer must submit to the Division of Public Transit the appropriate Buy America certification on **Bid Form #4** with all bids on FTA-funded contracts, except those subject to a general waiver. Bids or offers that are not accompanied by a completed Buy America certification must be rejected as non-responsive. This requirement does not apply to lower tier subcontractors.

Should the Vendor be declared responsive and low bid, pursuant to Pre-Award and Post Delivery Audit Requirements, the Division of Public Transit will require the Vendor to submit documentation (prior to any award) that lists:

- (1) Component and sub-component parts of the rolling stock to be purchased identified by manufacturer of the parts, their country of origin and costs; and
- (2) The location of the final assembly point for the rolling stock, including a description of the activities that will take place at the final assembly point and the cost of final assembly.
- (3) The Vendor shall submit one manufacturer's Federal Motor Vehicle Safety Standards (FMVSS) self-certification sticker providing information that the vehicle quoted complies with relevant FMVSS, or Manufacturer's certified statement that the contracted vehicles will not be subject to FMVSS regulations.
- (4) Vendor shall submit evidence that it will be capable of meeting the bid specifications.

As required by the Post Delivery Audit Requirement, any successful vendor will be required to furnish the following prior to any completed vehicle being placed into service or before any payment can be made:

- (1) Actual component and sub-component parts of the rolling stock provided, identified by manufacturer of the parts, their country of origin and costs; and
- (2) Actual location of the final assembly point for the rolling stock provided, including a description of the activities that took place at the final assembly point and the actual cost of final assembly.

8.12 Cargo Preference

The Vendor agrees:

8.12.1 To utilize privately owned United States--Flag commercial vessels to ship at least 50 percent of the gross tonnage (computed separately for dry bulk carriers, dry cargo liners, and tankers) involved, whenever shipping any equipment, material, or commodities pursuant to this contract, to the extent such vessels are available at fair and reasonable rates for United States--Flag commercial vessels;

8.12.2 To furnish within twenty (20) working days following the date of loading for shipments originating within the United States or within 30 working days following the date of leading for shipments originating outside the United States, a legible copy of a rated, "on board" commercial ocean bill of lading in English for each shipment of cargo described in the paragraph above to the Division of National Cargo, Office of Market Development, Maritime Administration, Washington, DC 20590 and to the Division of Public Transit (through the Vendor in the case of a subcontractor's bill of lading.)

8.12.3 To include these requirements in all subcontracts issued pursuant to this contract when the

subcontract may involve the transport of equipment, material, or commodities by ocean vessel.

8.13 Federal Regulation Changes

Vendor shall at all times comply with all applicable FTA regulations, policies, procedures and directives, including without limitation those listed directly or by reference in the Master Agreement (Form FTA MA(18) dated October 1, 2011) between the WV Department of Transportation, Division of Public Transit and FTA, as they may be amended or promulgated from time to time during the term of this Contract. Vendor's failure to so comply shall constitute a material breach of this contract.

8.14 Debarment and Suspension

This contract is a covered transaction for purposes of 49 CFR Part 29. As such, the contractor is required to verify that none of the contractor, its principals, as defined at 49 CFR 29.995, or affiliates, as defined at 49 CFR 29.905, are excluded or disqualified as defined at 49 CFR 29.940 and 29.945.

The contractor is required to comply with 49 CFR 29, Subpart C and must include the requirement to comply with 49 CFR 29, Subpart C in any lower tier covered transaction it enters into. By signing and submitting its bid or proposal, the bidder certifies as follows:

The certification in this clause is a material representation of fact relied upon by the WV Division of Public Transit. If it is later determined that the bidder knowingly rendered an erroneous certification, in addition to remedies available to the WV Division of Public Transit, the Federal Government may pursue available remedies, including but not limited to suspension and/or debarment. The bidder agrees to comply with the requirements of 49 CFR 29, Subpart C while this offer is valid and throughout the period of any contract that may arise from this offer. The bidder further agrees to include a provision requiring such compliance in its lower tier covered transactions. All Vendors shall be required to certify that they are not on the Comptroller General's list of ineligible contractors on **Bid Forms #6 and #6-A**.

8.15 Restrictions on Lobbying

Every Vendor who applies or bids for an award of \$100,000 or more shall file the certification on **Bid Form #9** required by C.F.R. Part 20.110, "New Restrictions on Lobbying." Each tier certifies to the tier above that it will not and has not used Federal appropriated funds to pay any person or organization for influencing or attempting to influence an officer or employee of any agency, a member of Congress, officer or employee of Congress, or an employee of a member of Congress in connection with obtaining any Federal contract, grant or any other award covered by 31 U.S.C. 1352. Each tier shall also disclose the name of the registrant under the Lobbying Disclosure Act of 1995 who has made lobbying contacts on its behalf with non-Federal funds with respect to that Federal contract, grant or award covered by 31 U.S.C. 1352. Such disclosures are forwarded from tier to tier up to the Division of Public Transit.

8.16 Environmental Regulations

The Vendor agrees to comply with all applicable standards, orders, or requirements issued under Executive Order 11738, and Environmental Protection Agency Regulations (40 CFR, Part 15), which prohibits the use under nonexempt federal contracts, grants or loans of facilities included on the EPA list of violating facilities. Any violations shall be reported to the Division of Public Transit who will forward the report to the Federal Transit Administration and to the US EPA Administrator for enforcement (9EN-329).

8.17 Clean Air

The Vendor agrees to comply with all applicable standards, orders or regulations issued pursuant to the Clean Air Act, as amended, 42 U.S.C. § 7414 and other applicable provisions of the Clean Air Act, as amended, 42 U.S.C. §§ 7401 *et seq.* The Vendor agrees to report each violation to the Division of Public Transit and understands and agrees that the Division of Public Transit will, in turn, report each violation as required to assure notification to FTA and the appropriate EPA Regional Office.

The Vendor also agrees to include these requirements in each subcontract exceeding \$100,000

financed in whole or in part with Federal assistance provided by FTA.

8.18 Clean Water

The Vendor agrees to comply with all applicable standards, orders or regulations issued pursuant to Section 508 of the Federal Water Pollution Control Act, as amended, 33 U.S.C. § 1368, and other provisions of the Federal Water Pollution Act, as amended, U.S.C. 1251 *et seq.* The Vendor agrees to report each violation to the Division of Public Transit and understands and agrees that the Division of Public Transit will, in turn, report each violation as required to assure notification to FTA and the appropriate EPA Regional Office.

The Vendor also agrees to include these requirements in each subcontract exceeding \$100,000 financed in whole or in part with Federal assistance provided by FTA.

8.19 Energy Conservation Requirements

The Vendor agrees to comply with mandatory standards and policies relating to energy efficiency which are contained in the State Energy Conservation Plan issued in compliance with the Energy Policy and Conservation Act.

8.20 Contract Work Hours and Safety Standards Act

The Vendor shall comply with Section 102 of the Contract Work Hours and Safety Standards Act (40 U.S.C. §§ 3701 *et seq.*, esp. § 3702) as supplemented by Department of Labor Regulations (29 CFR, § 5 & 29 CFR § 1926) as they involve the employment of mechanics and laborers.

Overtime Requirements. No Vendor or subcontractor for any part of the contract work which may require or involve the employment of laborers or mechanics shall require or permit any such laborer or mechanic in any workweek in which he or she is employed on such work to work in excess of forty hours in such workweek unless such laborer or mechanic receives compensation at a rate not less than one and one-half times the basic rate of pay for all hours worked in excess of forty hours in such workweek.

Violation; Liability for Unpaid Wages; Liquidated Damages. In the event of any violation of the clause set forth in paragraph (2) of this section, the Vendor and any subcontractor responsible therefore shall be liable for the unpaid wages. In addition, such Vendor and subcontractor shall be liable to the United States for liquidated damages. Such liquidated damages shall be computed with respect to each individual laborer or mechanic, including watchmen and guards, employed in violation of the clause set forth in paragraph (2) of this section, in the sum of \$10 for each calendar day on which such individual was required or permitted to work in excess of the standard workweek of forty hours without payment of the overtime wages required by the clause set forth in paragraph (2) of this section.

Withholding for Unpaid Wages and Liquidated Damages. The WV Division of Public Transit shall upon its own action or upon written request of an authorized representative of the Department of Labor withhold or cause to be withheld, from any moneys payable on account of work performed by the Vendor or subcontractor under any such contract or any other Federal contract with the same prime Vendor, or any other federally-assisted contract subject to the Contract Work Hours and Safety Standards Act, which is held by the same prime Vendor, such sums as may be determined to be necessary to satisfy any liabilities of such Vendor or subcontractor for unpaid wages and liquidated damages as provided in the clause set forth in paragraph (3) of this section.

Subcontracts. The Vendor or subcontractor shall insert in any subcontracts the clauses set forth in this section and also a clause requiring the subcontractors to include these clauses in any lower tier subcontracts. The prime Vendor shall be responsible for compliance by any subcontractor or lower tier subcontractor with the clauses set forth in this section.

Payrolls and Basic Records. Payrolls and basic records relating thereto shall be maintained by the Vendor during the course of the work and preserved for a period of three years thereafter for all laborers and mechanics working at the site of the work (or under the United States Housing Act of 1937, or under the Housing Act of 1949, in the construction or development of the project). Such records shall contain the name, address, and social security number of each such worker, his or her correct classification, hourly rates of wages paid (including rates of contributions or costs anticipated for bona fide fringe benefits or cash equivalents thereof of the types described in

Section 1(b)(2)(B) of the Davis-Bacon Act), daily and weekly number of hours worked, deductions made and actual wages paid. Whenever the Secretary of Labor has found under 29 CFR .5(a)(1)(iv) that the wages of any laborer or mechanic include the amount of any costs reasonably anticipated in providing benefits under a plan or program described in Section 1(b)(2)(B) of the Davis-Bacon Act, the Vendor shall maintain records which show that the commitment to provide such benefits is enforceable, that the plan or program is financially responsible, and that the plan or program has been communicated in writing to the laborers or mechanics affected, and records which show the costs anticipated or the actual cost incurred in providing such benefits.

Vendors employing apprentices or trainees under approved programs shall maintain written evidence of the registration of apprenticeship programs and certification of trainee programs, the registration of the apprentices and trainees, and the ratios and wage rates prescribed in the applicable programs.

8.21 Hold Harmless

The Vendor agrees to protect, defend, indemnify and hold the State of WV, the Division of Public Transit, its officers, employees and agents free and harmless from and against any and all losses, penalties, damages, settlements, costs, charges, professional fees or other expenses or liabilities of every kind and character arising out of or relating to any and all claims, liens, demands, obligations, action, proceedings or causes of action of every kind and character in connection with or arising directly or indirectly out of this Contract and/or the performance hereof. Without limiting the generality of the foregoing, any and all such claims, etc. relating to personal injury, infringement of any patent, trademark, copyright (or application for any thereof) or of any other tangible or intangible personal or property right, or actual or alleged violation of any applicable statute, ordinance, administrative order, rule or regulation, or decrees of any court, shall be included in the indemnity hereunder. The Vendor further agrees to investigate, handle, respond to, provide defense for and defend any such claims, etc., at his/her sole expense and agrees to bear all other costs and expenses related thereto, even if such claim is groundless, false or fraudulent.

8.22 Patent Infringement

The Vendor shall advise the Division of Public Transit of any impending patent suit and shall provide all information available. The Vendor shall defend any suit or proceeding brought against the Division of Public Transit based on a claim that any equipment, or any part thereof, furnished under this contract constitutes an infringement of any patent, and the Vendor shall pay all damages and costs awarded therein, excluding incidental and consequential damages, against the Division of Public Transit. In case said equipment, or any part thereof, is in such suit held to constitute infringement and use of said equipment or parts is enjoined, the Vendor shall, at its own expense and its option, either procure for the Division of Public Transit the right to continue using said equipment or part, or replace same with non-infringing equipment, or modify it so it becomes non-infringing.

9.0 AMENDMENTS TO SOLICITATION AND POSTPONEMENT OF BID DUE DATE

- A. The State of West Virginia reserves the right to amend any element or part of these bid documents and specifications and/or change the bid opening date and time, up to the time and date that bids are due. In this event, all potential Vendors that have received a copy of these contract documents and specifications shall be notified of the postponement and the new time and date that bids will be due. Such notification shall be mailed or otherwise provided. Any bids received in accordance with the original bid due date shall be held unopened until the new bid opening date.
- B. In the event that amendments are issued by the State fourteen (14) or more days prior to the original bid due date, the original date and time established for the receipt of bids, at the State's option, may or may not be changed. The addendum notification sent by the State shall contain either a statement that the bid due date remains as previously established or shall provide a new time and date if the bid due date is changed.

- C. In the event that addenda are issued by the State, Vendors must complete the Addendum Acknowledgment form contained within these contract documents and specifications and submit that form with their bid. **Bid Form #10** shall be used for this purpose.

10.0 BID PROTEST PROCEDURES

1. Filing of Protest(s)

Protests based on a violation of State law or rule must be filed no later than five (5) working days after issuance by the Purchasing Division of the notice of intent to award the contract or purchase order. Protests based on restrictive bid specifications or alleged improprieties in any type of solicitation, which are apparent prior to the bid opening or closing date for receipt of bids or proposals, must be filed no later than five (5) working days prior to the bid opening or closing date. Any other protest must be filed no later than five (5) working days following award of the contract or purchase order.

The Contractor is responsible for knowing the bid opening and award dates. Protests filed after the time frames specified above will not be considered. In addition, after these time frames, protests may not be amended, altered or changed.

All protests must be in writing and filed with the WV Purchasing Division containing the following:

- a) Include the name and address of the protester.
- b) Identify the requisition number of the bid or the purchase order number.
- c) Contain a statement of the grounds for protest and any supporting documentation.
- d) Indicate the ruling or relief desired from the WV Purchasing Division.

Failure to submit this information shall be grounds for rejection of the protest by the Director of the Purchasing Division.

No formal briefs or other technical forms of pleading or motion are required, but a protest and other submission should be concise, logically arranged, and clear.

The protest must be filed in writing with the:

Director
WV Purchasing Division
2019 Washington Street, East
P. O. Box 50130
Charleston, WV 25305-0130

with a copy of the protest sent to the:

Division of Public Transit
Building 5, Room 906
1900 Kanawha Boulevard, East
Charleston, WV 25305-0432

To expedite handling, the address should include **"ATTENTION: Bid Protest – Bid # 12031.**

Protests received timely will be reviewed and a written decision issued. **The Director of the WV Purchasing Division has the authority to make the final determination on any protest.**

2. Protest Review

The Purchasing Director or his/her designee shall review the matter of protest and issue a written decision. A hearing may be conducted at the option of the Purchasing Director or assigned designee.

3. Division of Public Transit Report/Response

The Division of Public Transit shall submit a complete report/response on the protest to the Director of the WV Purchasing Division responding in detail to each substantive issue raised in the protest, with a copy to the protester, as expeditiously as possible but not later than twenty-five (25) working days after being notified of the protest.

4. Withholding of Award

When a protest has been filed before award, the WV Purchasing Division will not make an award prior to the resolution of the protest, and when a protest has been filed before the opening of bids, the WV Purchasing Division will not open bids prior to the resolution of the protest, unless the WV Purchasing Division determines that:

- a) The items to be procured are urgently required; or
- b) Delivery or performance will be unduly delayed by failure to make the award promptly;
or
- c) Failure to make prompt award will otherwise cause undue harm to a recipient, the Division of Public Transit or the State of West Virginia.

In the event that the WV Purchasing Division determines that the award is to be made during the pendency of a protest, the Division of Public Transit will notify the Federal Transit Administration (FTA) prior to making such award.

5. Request for Reconsideration

Reconsideration of a decision by the WV Purchasing Division may be requested by the protester or any party involved in the protest. The request for reconsideration must be in writing, made to the Director of the Purchasing Division and shall contain the following:

- a) Include the name and address of the aggrieved party.
- b) Identify the requisition number of the bid or the purchase order number.
- c) Contain a detailed statement of the grounds for reconsideration with supporting documentation; and a statement of whether a hearing is requested.
- d) Indicate the ruling or relief desired from the WV Purchasing Division.

Request for reconsideration of a decision of the WV Purchasing Division shall be filed not later than five (5) working days after the initial written decision. The protest shall not be considered pending during the five(5) working day period specified in this paragraph.

In the event a hearing is requested by the aggrieved party, the Purchasing Director, or his or her designee, will set a time and place for the hearing for full review of the matter.

If no hearing is requested, the Purchasing Director, or his or her designee, will review the request for reconsideration and issue a written decision. If a hearing is requested, the Purchasing Director, or his or her designee, will hold the hearing and then issue a written decision.

6. Refusal of Protests

The State of West Virginia may refuse to decide any protest or reconsideration where the matter involved is one of the following:

- a) the protest is the subject of litigation before a court of competent jurisdiction;

- b) the protest has previously been decided on the merits by a court of competent jurisdiction;
- c) the protest has been decided in a previous protest.

The provisions do not apply where the court requests, expects, or otherwise expresses interest in the decision of the State.

7. Appeals to the Federal Transit Administration (FTA)

Under the Federal Transit Administration's Circular 4220.1F, the Federal Transit Administration's (FTA's) appeals process for reviewing protests of a recipient's procurement decisions are:

1. Requirements for the Protester. The protester must:

- a) Qualify as an "Interested Party." Only an "interested party" qualifies for FTA review of its appeal. An "interested party" is a party that is an actual or prospective bidder or offeror whose direct economic interest would be affected by the award or failure to award the contract at issue.
 - 1. Subcontractors. A subcontractor does not qualify as an "interested party" because it does not have a direct economic interest in the results of the procurement.
 - 2. Consortia/Joint Ventures/Partnerships/Teams. An established consortium, joint venture, partnership, or team that is an actual bidder or offeror and is acting in its entirety, would qualify as an "interested party" because it has a direct economic interest in the results of the procurement. An individual member of a consortium, joint venture, partnership, or team, acting solely in its individual capacity, does not qualify as an "interested party" because it does not have a direct economic interest in the results of the procurement.
 - 3. Associations or Organizations. An association or organization that does not perform contracts does not qualify as an "interested party," because it does not have a direct economic interest in the results of the procurement.
- b) Exhaust Administrative Remedies. The protester must exhaust its administrative remedies by pursuing the WV Division of Public Transit's protest procedures to completion before appealing the WV Division of Public Transit's decision to FTA.
- c) Appeal Within Five Days. The protester must deliver its appeal to the FTA Regional Administrator, Region III, 1760 Market Street, Suite 500, Philadelphia, PA 19103-4124 within five (5) working days of the date when the protester has received actual or constructive notice of the WV Division of Public Transit's final decision. Likewise, the protester must provide its appeal to the same address within five (5) working days of the date when the protester has identified other grounds for appeal to FTA. For example, other grounds for appeal include the WV Division of Public Transit's failure to have or failure to comply with its protest procedures or failure to review the protest.

2. Extent of FTA Review. FTA limits its review of protests to:

- a) Failure of the Division of Public Transit to have or adhere to its written bid protest procedures, or failure of the Division of Public Transit to review a complaint or protest.
- b) Alleged violations on other grounds are under the jurisdiction of the appropriate State or local administrative authorities.
- c) Alleged violations of a specific Federal Law or regulation that provides an applicable complaint procedure shall be submitted and processed in accordance with that Federal Law or regulation. See, e.g., Buy America Requirements, 49 C.F.R. Part 661 (Section 661.15); Participation by Minority Business Enterprise in Department of Transportation Programs, 49 C.F.R. Section 26.89.

FTA will exercise discretionary jurisdiction over those appeals involving issues important to FTA's overall public transportation program. FTA will refer violations of Federal law for which it does not have primary jurisdiction to the Federal authority having proper jurisdiction.

3. FTA Determinations to Decline Protest Reviews. FTA's determination to decline jurisdiction over a protest does not mean that FTA approves of or agrees with the Division of Public Transit's decision or that FTA has determined the contract is eligible for Federal participation. FTA's determination means only that FTA does not consider the issues presented to be sufficiently important to FTA's overall program that FTA considers a review to be required.

11.0 TERMINATION OF CONTRACT

The State reserves the right to cancel any purchasing agreement arising out of an award under these Specifications if, in its opinion, there is any failure to adequately perform the requirements of these Specifications. Under these conditions, cancellation will be effective immediately upon written notification to the Vendor and such cancellation will relieve the State from any obligation to purchase any items under such purchasing agreement.

11.1 Termination for Convenience

The performance of work under this Contract may be terminated by the Director of the Division of Purchasing in accordance with this clause in whole, or from time to time in part, whenever the Purchasing Division shall determine that such termination is in the best interest of the State. Any such termination shall be effected by delivery to the Vendor of a notice of termination specifying the extent to which performance of work under the Contract is terminated, and the date upon which such termination becomes effective.

After receipt of a notice of termination, and except as otherwise directed by the Purchasing Division, the Vendor shall: stop work under the Contract on the date and to the extent specified in the notice of termination; place no further orders or subcontracts for materials, services or facilities, except as may be necessary for completion of such portion of the work under the Contract as is not terminated; terminate all orders and subcontracts to the extent that they relate to the performance of work terminated by the notice of termination; assign to the State in the manner, at the time, and to the extent directed by the Purchasing Division, all of the right, title, and interest of the Vendor under the orders and subcontractors so terminated, in which case the State shall have the right, in its discretion, to settle or pay any or all claims arising out of the termination of such orders and subcontracts; settle all outstanding liabilities and all claims arising out of such termination of orders and subcontracts, with the approval or ratification of the Purchasing Division, to the extent as may be required, which approval or ratification shall be final for all the purposes of this clause, transfer title to the State and deliver in the manner, at the times, and to the extent, if any, directed by Purchasing Division the fabricated or unfabricated parts, work in process, completed work, supplies, and other material produced as part of, or acquired in connection with the performance of, the work terminated, and the completed or partially completed plans, drawing, information and other property which, if the Contract had been completed, would have been required to be furnished to the Division of Public Transit; use its best efforts to sell, in the manner, at the times, to the extent, and at the price(s) directed or authorized by the Purchasing Division, any property of the types referred to above, provided, however, that the Vendor shall not be required to extend credit to any purchaser, and may acquire any such property under the conditions prescribed by and at a price(s) approved by the Purchasing Division, and provided further, that the proceeds of any such transfer or disposition shall be applied in reduction of any payments to be made by the State to the Vendor under this Contract or shall otherwise be credited to the price or cost of the work covered by this Contract or paid in such other manner as the Purchasing Division may direct; complete performance of such part of the work as shall not have been terminated by the notice of termination; and take such action as may be necessary, or as the Purchasing Division may direct, for the protection or preservation of the property related to this contract which is in the possession of the Vendor and in which the State has or may acquire an interest.

Settlement of claims by the Vendor under this termination for convenience clause shall be in accordance with the provisions set forth in Federal Procurement Regulations (FPR) 18.701 (c), (d), (e), (f), (g), (h), (i), (j), and (k) except that wherever the word "Government" appears, it shall be deleted and the word "State" shall be substituted in lieu thereof.

11.2 Termination for Default

The Division of Public Transit may, by written notice of default to the Vendor, terminate the whole or any part of this Contract if the Vendor fails to make delivery of the supplies or to perform the services within the time specified herein or any extension thereof; or if the Vendor fails to perform any of the other provisions of the Contract, or so fails to make progress as to endanger performance of this Contract in accordance with its terms, and in either of these two circumstances does not cure such failure within a period of ten (10) days (or such longer period as the Purchasing Division may authorize in writing) after receipt of notice from the Purchasing Division specifying such failure.

If the Contract is terminated in whole or in part for default, the Division of Public Transit may procure, upon such terms and in such manner as the Purchasing Division may deem appropriate, supplies or services similar to those so terminated. The Vendor shall be liable to the Division of Public Transit for any excess costs for such similar supplies or services, and shall continue the performance of this Contract to the extent not terminated under the provisions of this clause.

Except with respect to defaults of subcontractors, the Vendor shall not be liable for any excess costs if the failure to perform the Contract arises out of causes beyond the control and without the fault or negligence of the Vendor. If the failure to perform is caused by the default of a subcontractor, and if such default arises out of causes beyond the control of both the Vendor and subcontractor, and without the fault or negligence of either of them, the Vendor shall not be liable for any excess costs for failure to perform, unless the supplies or services to be furnished by the subcontractor were obtainable from other sources in sufficient time to permit the Vendor to meet the required delivery schedule.

Payment for completed supplies delivered to and accepted by the Division of Public Transit shall be at the Contract price. The Division of Public Transit may withhold from amounts otherwise due the Vendor for such completed supplies such sum as the Purchasing Division determines to be necessary to protect the Division of Public Transit against loss because of outstanding liens or claims of former lien holders. If, after notice of termination of this Contract under the provision of this clause, it is determined for any reason that the Vendor was not in default under the provisions of this clause, or that the default was excusable under the provisions of this clause, the rights and obligations of the parties shall be the same as if the notice of termination had been issued pursuant to termination for convenience of the Division of Public Transit.

The rights and remedies of the Division of Public Transit provided in this clause shall not be exclusive and are in addition to any other rights and remedies provided by law or under this Contract.

12. NO GOVERNMENT OBLIGATION TO THIRD PARTIES

The Division of Public Transit and the Vendor acknowledge and agree that, notwithstanding any concurrence by the Federal government in or approval of the solicitation or award of the underlying contract, absent the express written consent by the Federal Government, the Federal Government is not a party to the Contract and shall not be subject to any obligations or liabilities to the Division of Public Transit, the Vendor, or any other party (whether or not a party to that contract) pertaining to any matter resulting from the underlying Contract.

The Vendor agrees to include the above clause in each subcontract financed in whole or in part with Federal assistance provided by FTA. It is further agreed that the clause shall not be modified, except to identify the subcontractor who will be subject to its provisions.

13. PROGRAM FRAUD AND FALSE OR FRAUDULENT STATEMENTS AND RELATED ACTS

The Vendor acknowledges that the provisions of the Program Fraud Civil Remedies Act of 1986, as amended, 31 U.S.C. §§ 3801 *et seq.* and U.S. DOT regulations, "Program Fraud Civil Remedies," 49 C.F.R. Part 31, apply to its actions pertaining to this Contract. Upon execution of the underlying contract, the Vendor certifies or affirms the truthfulness and accuracy of any statement it has made, it makes, it may make, or causes to be made, pertaining to the underlying contract or the FTA assisted project for which this Contract work is being performed. In addition to other penalties that may be applicable, the Vendor further acknowledges that if it makes, or causes to be made, a false, fictitious, or fraudulent claim, statement, submission, or certification, the Federal Government reserves the right to impose the penalties of the Program Fraud Civil Remedies Act of 1986 on the Vendor to the extent the Federal Government deems appropriate.

The Vendor also acknowledges that if it makes, or causes to be made, a false, fictitious, or fraudulent claim, statement, submission, or certification to the Federal Government under a contract connected with a project that is financed in whole or in part with Federal assistance originally awarded by FTA under the authority of 49 U.S.C. § 5307, the Government reserves the right to impose the penalties of 18 U.S.C. § 1001 and 49 U.S.C. § 5307(n)(1) on the Vendor, to the extent the Federal Government deems appropriate.

The Vendor agrees to include the above two clauses in each subcontract financed in whole or in part with Federal assistance provided by FTA. It is further agreed that the clauses shall not be modified, except to identify the subcontractor who will be subject to the provisions.

14. EXCLUSIONARY OR DISCRIMINATORY SPECIFICATIONS

The Vendor agrees that it will comply with the requirements of 49 U.S.C. § 5325(h) by refraining from using any Federal assistance awarded by the Division of Public Transit to support procurements using exclusionary or discriminatory specifications.

15. GEOGRAPHIC RESTRICTIONS

The Vendor agrees to refrain from using state or local geographic preferences, except those expressly mandated or encouraged by Federal statute, and as permitted by FTA.

16. APPLICATION OF FEDERAL, STATE AND LOCAL LAWS AND REGULATIONS

To achieve compliance with changing Federal, State and Local requirements, the Vendor shall note that Federal, State and Local requirements may change and the changed requirements will apply to this Contract as required.

17. BANKRUPTCY

Upon entering of a judgment of bankruptcy or insolvency by or against a Vendor, the Division of Public Transit may terminate this contract for cause.

18. PREFERENCE FOR RECYCLED PRODUCTS

The Vendor agrees to comply with all the requirements of Section 6002 of the Resource Conservation and Recovery Act, as amended (42 U.S.C. 6962), including but not limited to the regulatory provisions of 40 CFR Part 247, and Executive Order 12873, as they apply to the procurement of the items designated in Subpart B of 40 CFR Part 247.

19. METRIC SYSTEM

To the extent required by the U.S. Department of Transportation or the Federal Transit Administration, the Vendor agrees to use the metric system of measurement in its Contract activities, as may be required by 15 U.S.C. §§ 205a *et seq.*; Executive Order No. 12770, "Metric Usage in Federal Government Programs," 15 U.S.C. § 205a note; and other regulations, guidelines, and policies issued by the U.S. Department of Transportation or the Federal Transit Administration. To the extent practicable and feasible, the Vendor agrees to accept products and services with dimensions expressed in the metric system of measurement.

20. LICENSING AND PERMITS

The Vendor shall be appropriately licensed for the work required as a result of the Contract. The cost for any required licenses or permits shall be the responsibility of the Vendor. The Vendor is liable for any and all taxes due as a result of the Contract.

21. COMPLIANCE WITH LAWS AND PERMITS

The Vendor shall give all notices and comply with all existing and future Federal, State and Municipal Laws, Ordinances, Rules, Regulations, and Orders of any public authority bearing on the performance of the Contract, including, but not limited to, the laws referred to in these provisions of the Contract and the other Contract documents. If the Contract documents are at variance therewith in any respect, any necessary changes shall be incorporated by appropriate modification. Upon request, the Vendor shall furnish to the Division of Public Transit certificates of compliance with all such laws, orders, and regulations.

22. SEVERABILITY

In the event any provision of the Contract is declared or determined to be unlawful, invalid or unconstitutional, such declaration shall not affect, in any manner, the legality of the remaining provisions of the Contract and each provision of the Contract will be and is deemed to be separate and severable from each other provision.

23. INCORPORATION OF FEDERAL TRANSIT ADMINISTRATION (FTA) TERMS

The preceding provisions include, in part, certain Standard Terms and Conditions required by the U.S. Department of Transportation (DOT), whether or not expressly set forth in the preceding Contract provisions. All contractual provisions required by DOT, as set forth in FTA Circular 4220.1F, dated November 1, 2008, are hereby incorporated by reference. Anything to the contrary herein notwithstanding, all FTA mandated terms shall be deemed to control in the event of a conflict with other provisions contained in this Contract. The Vendor shall not perform any act, fail to perform any act, or refuse to comply with any Division of Public Transit requests which would cause the Division of Public Transit to be in violation of the FTA terms and conditions.

24. ACCESS TO RECORDS

The Vendor agrees to permit the WV Division of Public Transit, the Secretary of the United States Department of Transportation and the Comptroller General of the United States, or their authorized representatives, to inspect all Contract work, materials, payrolls, and other data and records with regard to the Contract. The Vendor also agrees to permit an audit of the books, records, and accounts of the Vendor and its subcontractors.

25. ACCESSIBILITY

Vendor agrees that any vehicles provided shall be in accordance with the 42 U.S.C. Sections 12101 et seq. and DOT regulations, "Transportation Services for Individuals with Disabilities (ADA)," 49 CFR Part 37; and Joint ATBCB/DOT regulations, "American with Disabilities (ADA) Accessibility Specifications for Transportation Vehicles," 36 CFR Part 1192 and 49 CFR Part 38.

26. SENSITIVE SECURITY INFORMATION

Each Vendor must protect, and take measures to ensure that its subcontractors at each tier protect, "sensitive security information" made available during the administration of this contract or any subcontract to ensure compliance with 49 U.S.C. Section 40119(b) and implementing DOT regulations, "Protection of Sensitive Security Information," 49 CFR Part 15, and with 49 U.S.C. Section 114(s) and implementing Department of Homeland Security regulations, "Protection of Sensitive Security Information," 49 CFR Part 1520.

27. SEAT BELT USE

In compliance with Federal Executive Order No. 13043, "Increasing Seat Belt Use in the United States," April 16, 1997, 23 U.S.C. Section 402 note, FTA encourages each vendor to adopt and promote on-the-job seat belt use policies and programs for its employees and other personnel that operate company owned, rented, or personally operated vehicles, and to include this provision in any third party subcontracts, involving this project.

28. AIR POLLUTION AND FUEL ECONOMY

Vendor is to ensure compliance with applicable Federal air pollution control and fuel economy regulations, such as EPA regulations, "Control of Air Pollution from Mobile Sources," 40 CFR Part 85; EPA regulations, "Control of Air Pollution from New and In-Use Motor Vehicles and New and In-Use Motor Vehicle Engines," 40 CFR Part 86; and EPA regulations, "Fuel Economy of Motor Vehicles," 40 CFR Part 600.

29. TRAINING

The Vendor shall have at its own expense one or more qualified instructor(s) who shall be available at the Recipient Agency(ies) property for up to 3 calendar days per month between the hours of 8:00 a.m. to 5:00 p.m. for one (1) month prior and 5 calendar days two (2) months after, acceptance of the first vehicle. Training must take place at each Recipient Agency's property. The dates will be mutually agreed upon. Instructors shall conduct schooling sessions during the beginning of this two month period which shall be designed to instruct the Recipient Agency's (ies) in-house driver training staff in proper and safe on-road operation of the vehicle, in operating characteristics and limitations of the vehicle, and identification and proper operation of all driver's controls. Instructors shall also, during the beginning of this period, conduct training sessions for maintenance instructors and qualified mechanics to give thorough and proper training in the maintenance and repair of all operating systems of the vehicle including: (1) power train, (2) electrical system, (3) heating, ventilation and air conditioning system, (4) braking and air system, and (5) wheelchair lift and securement systems. The Vendor shall also provide visual and other teaching aids for use by each Recipient Agency's (ies) own training staff.

30. ADDITIONAL OPTIONS

Additional options, at the dealer's cost, may be added at a later date. The successful vendor must provide documented proof of the dealer cost of the option at the time of the purchase order.

31. NOTIFICATION OF FEDERAL PARTICIPATION

Federal funding for this project is being provided by the Federal Transit Administration through various CFDA grants for 80% of the project cost. CFDA grants will be specified after award.

Any questions regarding this proposal should be addressed to:

**Paul Reynolds
Buyer
Building 15
2019 Washington Street, East
Charleston, WV 25305
PHONE: 304-558-0468
E Mail: Paul.Reynolds@wv.gov**

PART 2 - TECHNICAL SPECIFICATIONS

138" WHEELBASE DUAL REAR WHEEL (DRW) NARROW BODY CUTAWAY

1.0 General

1.1 Scope

Technical specifications establish requirements for a vehicle to provide specialized transportation services in an urban and suburban-rural environment, including hilly terrain and severe winter operating conditions.

The bid should be in bound form with each section properly labeled with the required information attached to each section. Two (2) copies of the bid form should be sent to the West Virginia Purchasing Division with one (1) copy clearly marked for the West Virginia Division of Public Transit.

1.2 General Characteristics

The vehicles furnished shall conform to the following general characteristics listed below and the detailed specifications and options that follow:

WHEELBASE	138" minimum
REAR AXLE	Dual Rear Wheel
GVWR	11,500
TIRE	LT225/75Rx16
LOAD RATING	E
WIDTH (MAXIMUM)	84.5"
OVERALL LENGTH (APPROXIMATE)	263"
OVERALL HEIGHT (MAXIMUM)	115"
TURNING RADIUS (MAXIMUM)	25.5"
SEAT/ WHEELCHAIR CAPACITY	Driver + 4 seated passengers+ 2 wheelchairs positioned Front/rear + 2 double foldaway seats
PASSENGER HEAT	1 x 35,000
PASSENGER A/C	53,000 separate from dash A/C; requires dual compressors
ENGINE TYPE	V-8
SPARE TIRE	Loose
BATTERY	Dual
FAST IDLE	Yes
CURBSIDE EMERGENCY WINDOWS	1 minimum
STREETSIDE EMERGENCY WINDOWS	2 minimum

1.3 Definitions

The following terms are used in PART 2 – TECHNICAL SPECIFICATIONS:

Curb Weight: Weight of the vehicle including maximum fuel, oil, and coolant and all equipment required for the operations as required by this specification without passengers or driver.

Gross Load: One hundred and fifty (150) pounds for every permanent passenger seating position and for the driver, and 300 pounds for every wheelchair station. Vehicles will be operated without standees.

GVW (Gross Vehicle Weight): Curb weight plus gross load.

Fireproof: Materials that will not burn or melt at a temperature less than 2000 degrees Fahrenheit.

Fire resistant: Materials that have a flame spread index of less than 150 as measured in a radiant panel flame test per ASTM 162-75.

1.4 Abbreviations:

The following abbreviations are used in Part 2: TECHNICAL SPECIFICATIONS:

ASTM: American Society for Testing and Materials

ADA: Americans with Disabilities Act of 1990 including applicable Federal regulations issued pursuant to the Act in effect on the date of the bid award.

FTA: Federal Transit Administration

FMVSS: Federal Motor Vehicle Safety Standards

DMV: Division of Motor Vehicles, State of West Virginia

OEM: Original Equipment Manufacturer

SAE: Society of Automotive Engineers

1.5 Legal Requirements

The vehicle shall meet all applicable FMVSS, DMV, ADA, federal and state regulations in effect at the date of manufacture. The vendor shall comply with all applicable federal and state regulations in the manufacturing of the vehicles. **Vendor shall supply certification that vehicle meets all FMVSS regulations.**

1.6 Components, Materials, Workmanship, and Completeness

All units or parts not specified shall be manufacturer's best quality and shall conform in material, design or workmanship to the best practice known in the automotive industry. All parts shall be new and in no case will be used, reconditioned, or obsolete parts be accepted. The part on all vehicles provided by the same manufacturer shall be interchangeable.

1.7 Motor Vehicle Standards Including Provisions Pertaining to Safety and Pollution

The vendor will provide certification at the time of delivery that vehicles comply with all relevant Federal and State of West Virginia standards.

1.7.1 Motor Vehicle Safety

The motor vehicles furnished shall comply with applicable motor vehicle safety standards established by the U.S. Department of Transportation and the State of West Virginia.

1.7.2 Exhaust Emissions Control Requirements

The vehicles shall comply with all federal and state requirements applicable to the year of manufacture.

1.7.3 Noise control

The exterior noise from the vehicle shall not exceed eighty-six (86) dba using the procedures set forth in the SAE standard SAE J 366.

The interior noise at a location two (2) feet away from the rear window and four (4) feet from the floor shall not exceed 86 dba with the vehicle standing with the transmission in neutral and the engine operating at a maximum rated RPM.

1.8 Inspection Facilities

In order to comply with Part 4, section 6.1, Inspection Stations, the manufacturer shall provide on its premises a suitable hoist for a complete inspection of the underside of the vehicle. This includes, but is not limited to, wiring and hosing runs, structural integrity, through floor securements, OEM defects and completeness, and coverage of the undercoating. **A pit is not acceptable.**

2.0 Chassis

Chassis shall be OEM's original wheelbase. Cutting between the axles to extend the wheelbase is not allowed. Chassis extensions behind the rear axle to support the body shall be in accordance with OEM's recommended practices and painted to match the original. All welds and cuts shall be properly dressed and deburred to present a professional finish.

3.0 Engine & Transmission

3.1 Engine and Related Components

Engine shall be V-8, heavy duty gasoline powered. **It is recommended that the vendor submit product description, warranty information, and product literature with bid.**

3.1.1 The engine shall be furnished with a large capacity full flow oil filter easily reached and replaced without removal of any major component. A dry type air cleaner is required.

3.1.2 The engine shall be installed so as to so as to produce a minimum of vibration. A firewall of sandwich construction shall separate the engine and passenger compartments, providing both thermal and acoustic insulation and sealing against intrusion of exhaust fumes into the vehicle. Non-combustible insulation shall be used.

3.1.3 Two (2) ambulance bilge-style cooling ports shall be installed on OEM hood to facilitate air exchange in the engine compartment.

3.1.4 Exhaust System

The muffler shall be a low exterior noise type. The tail pipe shall be extended approximately two (2) inches beyond the streetside of the vehicle. A minimum of two (2) heavy duty exhaust hangers is required from the rear axle to the rear extension of the vehicle. Hangers shall be bolted to chassis or structure, **NOT WELDED.**

3.1.5 Fuel System

A single fuel tank shall have a capacity of at least 35 gallons and be located between the chassis rails behind the rear wheels.

3.1.6 Cooling System

The cooling system shall have sufficient capacity to provide satisfactory cooling at 115 degrees Fahrenheit at sea level, and shall be equipped with an overflow tank such that coolant expelled is saved and restored to the cooling system. The cooling system shall be the OEM chassis supplier's heaviest duty system **It is recommended that the vendor submit product description, warranty information, and product literature with bid.**

3.1.7 High Idle System

A high-idle system, intended to maintain battery charging under heavy demand when the vehicle is stationary and the emergency brake is applied shall be provided on all vehicles. The fast idle switch will automatically disengage when the vehicle is placed in forward or reverse gears. **It is recommended that the vendor submit product description, warranty information, and product literature with bid.**

3.1.8 Engine Oil Cooler

An OEM or other appropriate oil cooler shall be provided. **It is recommended that the vendor submit product description, warranty information, and product literature with bid.**

3.2 Transmission and Related Components

3.2.1 The transmission shall be automatic with a minimum of four (4) forward speeds.

3.2.2 The transmission and drive shall be heavy duty.

3.2.3 Each section of the drive shaft shall be equipped with a guard to prevent the shaft from striking the passenger compartment floor or the ground in the event it should break.

3.2.4 The transmission shall have the OEM's separate cooling system appropriate for the configuration of the vehicle. **It is recommended that the vendor submit product description, warranty information, and product literature with bid.**

4.0 Brakes, Steering, Suspension, and Related Components

4.1 Brakes

The vehicle shall be equipped with the most heavy duty brake configuration available on the OEM chassis. The system shall provide braking performance meeting all federal and state requirements for the GVWR being offered.

At a minimum, it shall consist of:

Service brakes with power assisted dual hydraulic actuation. Anti-lock braking shall be provided to the maximum extent available from the OEM chassis supplier.

Emergency parking brakes shall be provided on the driveline or rear brakes.

It is recommended that the vendor submit product description, warranty information, and product literature with bid.

4.2 Steering

4.2.1 Steering shall be power assisted

4.2.2 The steering mechanism shall be constructed so that the vehicle can be easily steered by its operator and shall be such as to make the wheel free from road shock and vibration. The steering mechanism shall be self centering, requiring little or no effort from the operator to bring the vehicle back to a straight ahead position after turning. Steering wheel ring shall be no greater than 20 inches in diameter and the wheel ring shall be of plastic or synthetic resin construction molded over metal.

4.2.3 With the vehicle stationary at GVW on dry, level pavement and the engine idling, steering effort shall be as low as possible at the steering wheel. This effort shall remain approximately constant from just off straight-ahead to approaching full lock.

4.2.4 The steering geometry shall allow the turning radius required in 1.2 General Characteristics to be achieved in both directions.

4.2.5 A tilt-wheel or adjustable steering column, if available, with cruise control is required.

4.3 Suspension

Suspension system shall be the highest rating available. Suspension systems shall provide the low, unsprung weight characteristics necessary for passenger comfort without sacrificing vehicle stability and shall provide heavy-duty shock absorbers. A front axle with independent suspension is preferred. **It is recommended that the vendor submit product description, warranty information, and product literature with bid.** Vendor must perform a front end alignment after each vehicle is completely built. The vendor shall supply a camber and caster kit for each vehicle. Vendor shall supply a statement of completion certifying that alignment was completed with warranty information.

4.3.1 MOR/Ryde Suspension System or Approved Equals

Rubber shear spring suspension that works in conjunction with the chassis steel leaf spring suspension to absorb road shock. **It is recommended that the vendor submit product description, warranty information, and product literature with bid.**

4.4 Wheels and Tires

4.4.1 Wheels. 16.0 (d) x 6.00" width or size compatible with the suspension and GVWR will be furnished. **Each inner dual rear wheel shall come with an air valve extender. It is recommended that the vendor submit product description, warranty information, and product literature with bid.**

4.4.2 Tire Rating and Type. E rating truck and all weather radial type.

4.4.3 Spare Wheel and Tire. Manufacturer shall provide a spare tire as standard equipment. The spare wheel and tire shall be sized per 4.4.1 and 4.4.2 and shall be shipped loose in the body of the vehicle approximately secured so as not to damage the vehicle interior during shipment. Spare is to be the exact same tire as provided on the vehicle. Spare tire shall be painted as per 4.4.4, and it shall be inflated to the proper pressure with air, not nitrogen.

4.4.4 Both inner and outer wheels shall be painted to match the basic body color, which is white.

5.0 Electrical System

The vehicles are to be supplied with a twelve (12) volt electrical system. All components are to be selected and integrated to function in an environment characterized by low engine (alternator) speeds and high amperage draws, due to lights, flashers, air conditioning or heaters, and other accessories in constant operation. **As Built Schematics must be supplied and current with all vehicles in Word or Adobe reader format. All wiring in all vehicles shall be as built. All wiring shall be loomed and held in place by insulated clamps spaced every 12 inches on center.** Wiring shall be system coded, numbered, and function coded. All wiring must be at least 14 gauge. All wiring shall have adequate electrical insulation and provide flexibility and resistance against solvents or abrasives in accordance with SAE standards. All exposed underbody connectors shall be weather proofed for protection

5.1 Alternator

OEM 225-amp alternator with a rectifier is required. Rectifier may be either integral or externally connected. **Bidder shall specify the nature of the rectifier and method of installation.** The voltage regulator shall be solid state. The alternator shall be sized to provide a minimum of 90 percent of the continuous system draw at the engine manufacturer's recommended idle or 100 percent at automatic fast idle as specified in 3.1.7 (High Idle System). The alternator speed shall not exceed its recommended maximum or recommended high engine speed. The continuous system draw shall include all accessories in their "high" position, which could operate as the vehicle is in motion; i.e., excluding intermittently operating devices, such as turn signals, brake lights, or wheelchair lifts. **It is recommended that the vendor submit product description, warranty information, and product literature with bid.**

5.2 Batteries

Two heavy-duty 12 volt batteries shall be provided with a minimum total capacity of 1275 CCA. **It is recommended that the vendor submit product description, warranty information, and product literature with bid.**

Batteries shall be at an easily accessible location from the exterior of the vehicle. Any chassis OEM battery located under the hood shall remain there. The second battery is to be installed in a stainless steel battery box on a stainless steel slide-out tray located on the curb side of the bus. An access door will be provided in the skirt to access this battery box. The access door will be secured with two (2) quarter-turn latches.

5.3 Exterior lights

- 5.3.1 All exterior lights to be single contact. Double contact may be used for tail, stop, and rear turn signals.
- 5.3.2 Headlights of sealed beam type are required with high and low beams controlled by a column-mounted lever switch or by a foot switch mounted on the floor, which will be sealed from moisture. Sealed beam units shall be of the latest type and low beam rating of 600-hour life. **Headlights shall be wired for daytime running.**
- 5.3.3 Directional signals independent of the brake lights shall be provided and shall have sealed amber lens in front and rear. Rear stoplights are to be independent of directional and hazard warning signals.
- 5.3.4 LED rear stop and taillights shall be provided. Rear stoplights are to be independent of directional and hazard warning lights. **Provide detailed information on the installed LED lights with the bid submittal. It is recommended that the vendor submit product description, warranty information, and product literature with bid.**
- In addition to the normal stop lights provided on the base vehicle as extra LED stoplight shall be provided. The light shall be mounted on the centerline of the vehicle above the rear door and shall be wired to work in conjunction with the normal stoplights. This extra light shall be treated as a brake light.
- 5.3.5 Red rear reflectors and two reflectors on each side of the vehicle, amber front and red rear, shall be provided.
- 5.3.6 LED side directional signals wired to operate with front directional signals shall be provided.
- 5.3.7 A circuit shall be provided for the directional signals which, when on, will cause them to function as traffic hazard warning signals.
- 5.3.8 An LED rear license plate light shall be provided that meet Federal and State of West Virginia regulations.
- 5.3.9 Two (2) LED back-up lights shall be provided that meet Federal and State of West Virginia regulations.
- 5.3.10 An LED wheelchair lift light shall be located inside the vehicle to illuminate the lift. Two (2) additional LED lights will be mounted on the skirt below the lift to illuminate the surrounding area of the street. The lights shall function automatically when the lift door is opened, even when the running lights switch is in the off position, to provide illumination in accordance with FTA/ADA requirements. Installation of the lights shall not intrude upon the headroom or effective width of the wheelchair access area. **It is recommended that the vendor submit product description, warranty information, and product literature with bid.**
- 5.3.11 LED marker, cluster, and all other lights as required by State and Federal regulations shall be provided. Lights shall operate with or without the engine running.
- 5.3.12 The rear hazard flashers shall be activated when the lift operating circuits are energized.
- 5.3.13 All lights are to be LED lights with the exception of the dome lights and headlights.

5.4 Interior Lighting

- 5.4.1 The interior shall be illuminated by LED fixtures. Interior shall be illuminated to provide a minimum of twelve (12) foot candles of illumination measured at thirty-six (36) inches above the floor over each two-passenger cross seat. **Provide detailed information on the installed interior lights with the bid submittal. It is recommended that the vendor submit product description, warranty information, and product literature with bid.**
- 5.4.2 The stepwell area shall be illuminated to FTA/ADA standards by door activated LED stepwell lights including the immediate area outside. These lights shall be shielded to protect passengers' eyes from glare. Light fixtures shall be totally enclosed, splash-proof, designed to provide ease of cleaning as well as lamp housing removal and shall not be easily removed by passengers. Stepwell lights shall be protected from damage caused by passengers kicking the lenses or fixtures and shall not be a hazard to passengers. Stepwell lights shall be activated by operating the passenger door even with the running lights switch in the OFF position.
- 5.4.3 Red LED location indicator lights shall be provided above all emergency exits.

5.5 Wiring

- 5.5.1 All wiring shall have adequate electrical insulation to provide flexibility and resistance against solvents or abrasives in accordance with SAE standards.
- 5.5.2 Wiring shall be correctly grouped, coded, and installed such that systems checks, maintenance, and replacement can be affected with minimum effort.
- 5.5.3 Wiring shall be adequately supported and where penetration of structural members occurs, grommets or similar devices shall be used to prevent chafing.
- 5.5.4 Where applicable, all circuits shall be suppressed with capacitors to eliminate interference with radio and TV transmissions and reception.

5.6 Audible Alarms

- 5.6.1 A twelve (12) volt horn shall be situated beneath the front end of the vehicle, protected from wheel wash.
- 5.6.2 A rear alarm shall be provided that is clearly audible outside of the vehicle while the transmission is in reverse. **It is recommended that the vendor submit product description, warranty information, and product literature with bid.**
- 5.6.3 An audible door ajar alarm shall be provided for any rear emergency door.

- 5.7 A back up camera system will be installed on each bus so that the area around the back of the bus clearly displayed on a monitor that is mounted in an easily visible area for the driver. **It is recommended that the vendor submit product description, warranty information, and product literature with bid.**

5.8 Electrical Fuses/ Circuit Breakers

All fuses and/or circuit breakers other than the OEM's chassis shall be placed in a waterproof electrical distribution panel located above the driver's door, accessible from inside the bus. Fuses will be automotive mini blade type fuses that plug into a modular distribution block, such as Cooper Bussman Series 3000 VEC, RCT, or approved equal. The distribution panel access door shall be side or bottom hinged and contain a readily visible circuit diagram of the electrical services.

6.0 Heating, Air Conditioning, and Ventilation

6.1 Heating System

- 6.1.1 The heating system shall provide heat for both the driver and passengers as well as defrost air for the windshield. The system shall provide for a comfortable temperature for passengers throughout the vehicle by providing heat from both a dash and passenger compartment heater. **It is recommended that the vendor submit product description, warranty information, and product literature with bid.**
- 6.1.2 An electrical stepwell system heater, **to be approved by the Division of Public Transit**, shall be provided to eliminate ice and snow build-up. Heater using the coolant system shall be stainless steel. **It is recommended that the vendor submit product description, warranty information, and product literature with bid.**
- 6.1.3 A passenger compartment heater shall be provided towards the back of the vehicle to ensure consistent heat distribution throughout the vehicle. Gate valves shall be provided to allow the rear heater system to be shut off. Heater fans shall have high and low speeds. (Heater Capacity 1 x 35,000 BTU minimum). **It is recommended that the vendor submit product description, warranty information, and product literature with bid.**

6.2 Air Conditioning System

The OEM chassis supplier's heaviest duty air-conditioning system shall be supplied plus such other components as necessary to ensure effective, uniform cooling throughout the vehicle. Trans Air, ACC, Burgess, or ACT or approved equals are recommended. At a minimum, the system should consist of:

- 6.2.1 The OEM's engine driven compressor with a minimum displacement of 9 cubic inches. Provide a secondary engine-driven compressor of sufficient size to circulate the rear A/C per specifications.
- 6.2.2 The OEM's front mounted condenser shall not be removed. **It is recommended that the vendor submit product description, warranty information, and product literature with bid.**
- 6.2.3 A two fan oversized (minimum fan size-14"; rated at 62,000 BTU's per hour), skirt-mounted condenser shall be shielded from road spray.
- 6.2.4 A ceiling mounted evaporator at the rear of the passenger compartment with a minimum capacity of 53,000 BTUs and separate fan speed control.

The A/C system shall utilize environmentally friendly R-134a refrigerant. Refrigerant hoses shall be double braided (type C, class II) and the refrigerant hoses and fittings must be SAE specification J2064 compliant.

All A/C hoses, heater hoses and wiring shall be properly protected. The A/C systems will include, as standard, ATCO, Quick Click, or approved equal connectors and hoses. Beadlock fittings and rubber barrier hoses are not acceptable.

6.3 Roof hatch

Vehicles shall be equipped with one five (5)-way, 23" x 23" vent/escape hatch, Transpec Model 1975 or approved equal. **It is recommended that the vendor submit product description, warranty information, and product literature with bid.**

7.0 Instruments and Controls

7.1 Instruments

As a minimum, the following instruments are to be provided:

- 1) Speedometer with recording odometer;
- 2) Ampmeter and voltmeter;
- 3) Oil pressure gauge;
- 4) Fuel tank level gauge;
- 5) Engine temperature gauge;
- 6) Parking brake indicator;
- 7) Head light high-beam indicator;
- 8) Directional signal and flasher action light;
- 9) and power port for cellular phone.

All instruments are to be grouped on a single panel in full view of the driver with no instruments obstructed by controls, trim panels, or other appurtenances and arranged in a consistent and uniform manner.

7.2 Controls

At least the following controls, in addition to the normal steering, braking, and transmission functions, are to be provided:

- 1) column mounted turn signal lever
- 2) emergency flasher control facing driver and clearly visible
- 3) master exterior light switch and auxiliary switches, if necessary, for any clearance or marker lights
- 4) switches and controls for passenger compartment heaters and air-conditioners
- 5) three speed wiper control with high, low, and intermittent speeds (the wiper control may be panel or column mounted)
- 6) passenger compartment lights.

All controls are to be within driver's arm reach (no more than 28") with seat belt fastened. All switches are to be mounted in convenient groupings in a panel near the driver.

The Division of Public Transit must approve location of all controls.

7.3 Circulation Fan

A two-speed heavy duty commercial vehicle circulation fan shall be provided in the driver's area for increased circulation. The fan shall be a minimum of 6" in diameter with at least a three-position control switch. **Location will be approved by the Wet Virginia Division of Public Transit.**

8.0 Body

8.1 General

8.1.1 Body shall be steel framed with a minimum 18-gauge steel and be built as an integral welded unit mounted on a chassis and adequately reinforced at all joints where stress concentration may occur. Side walls, rear wall, roof, and floor must be welded together; joining by other means is not acceptable. **Details of body construction including materials, methods of joining and assembling components or sub-assemblies and method of attachment of the body to the chassis shall be submitted.** Honeycomb construction is not acceptable.

Roof structure to include two roll bars fabricated from steel tubing incorporated into roof structure to provide additional strength.

- 8.1.2 Federal and state requirements including FMVSS #220 Rollover Protection are required to be met. The side and end forming shall be so designed and constructed that they will carry their proportion of the stresses imposed and absorb excessive impacts with as little damage as is practical. Adequate reinforcement shall be installed around all doors in order to transfer the stresses around these openings. All posts in body, side, and roof sections shall be of square section tubing or equal construction securely fastened to the under frame structure so that the entire frame shall act as one unit without any movement at the joining. The end posts shall be designed to standards, as required for federal and State standards for shear, static load on roof, and side panel impact protection.
- 8.1.3 Before assembling, all steel components are treated with an anti-corrosive, petroleum based primer that meets ASTM B117 (3500 hrs) and ASTM D870 (1000hrs). **It is recommended that the vendor submit product description, warranty information, and product literature with bid.**
- 8.1.4 All nuts, bolts, clips, washers, clamps, and like-parts shall be galvanized, zinc-coated, or given a coat of primer as additional protection against corrosion. All exterior screws and bolts shall be stainless steel.
- 8.1.5 Interior surfaces of any exterior painted body panels and posts which are covered by trim materials shall be given a coat of primer as additional protection against deterioration.
- 8.1.6 All exterior joints and seams shall be protected by the application of caulking compound of Sikaflex or an approved equal.
- 8.1.7 All interior and external panels shall be bonded to the body frame without the use of mechanical fasteners, such as screws or rivets. Two sided tape is unacceptable. Adhesive alone is unacceptable. Exterior panels shall be applied in a single piece (no seams). The only seams allowed will be where the sidewalls, rear wall, and roof are joined together. All fasteners shall be installed to resist vibratory loosening. Exterior seams shall be constructed in such a manner that they shed water; the roof panel shall be lapped over the side panel, and the side panel shall overlap the skirt, and in no case shall the sealing of the panels be dependent on caulking alone. All exterior joints and seams shall be protected by the application of caulking compound, such as Sikaflex, butyl rubber type, or approved equal.
- 8.1.8 All vehicles purchased under this contract shall, during the course of manufacture and prior to acceptance, shall be subjected to a water test to determine body leaks. This test shall consist of a series of nozzles, which are strategically located around the perimeter of the vehicle as to spray water over the entire surface of the vehicle. The nozzles shall eject a volume of water no less than twenty-two pounds per square inch measured at the nozzle tip. Body shall be thoroughly water tested and made tight to prevent leakage. **The bidder shall provide the procuring agency with details of its water testing procedure with the bid.**
- 8.1.9 All exposed surfaces and edges shall be smooth, free from burrs and other projections, and shall be neatly finished.
- 8.1.10 The passenger entrance frame and wheelchair door frame shall be aluminum or stainless steel construction only.
- 8.1.11 The front cap shall have an extra framed support from the side of the passenger entrance door to the floor.
- 8.2 Body panels
- 8.2.1 Body Panels

Roof shall be one piece metal, fiberglass, or approved equal panel with one and one-half (1-1/2") minimum thickness rigid foam insulation or equivalent. Side panels above the floor line shall be one piece fiberglass

reinforced plastic (FRP), steel, aluminum, or approved equals on the exterior, of one piece construction, firmly attached to prevent flexing of the panels to the frame structure to present a smooth pleasant appearance and to be free from drumming or oil canning. Vacuum lamination is the preferred method.

Side panels (skirt) below the floor line shall be detachable aluminum and separate from the above panels for ease of the maintenance and repair. An aluminum or galvanized steel underfloor shall be provided for the whole of the passenger compartment, and it shall be fully undercoated.

Stepwells shall be of one-piece stainless steel or aluminum construction welded into the floor and side structures. The bottoms of the steps and risers will be coated with undercoating, such as Z Tech Z guard 20060 B-2 or an approved equal. Stepwells shall be of one piece construction of corrosion resistant steel, with covered corners and adequate reinforcement to prevent deflection. Stepwell shall be the full width of the door opening, and designed like the Talon Tread-type step or approved equal, which eliminates separation and exposure of metal to moisture on the treads and risers. The preferred method of manufacturing is a process where the contrasting step nosing and flooring are heated with the metal step well so that the metal and flooring material are fused with fewer seams and less caulking. The entire underside of the vehicle should be fully undercoated. The nosing of each step shall be marked with bright yellow marking with abrasive strip insert not less than one (1) inch wide, preferably of a reflective type material. All flooring shall be blue with the entrance area covered with 3/16" ribbed floor covering and the flooring under the seats shall be smooth 1/8" floor covering. White flooring will not be accepted. Aisle and securement area shall be 3/16 ribbed floor covering. **It is recommended that the vendor supply the description, warranty, and literature information of this product.**

Wheel housings shall be steel and should provide clearance for wheels equipped with chains to move freely and to allow a wheel to be removed with the vehicle jacked on the rear axle. **Application of exterior sidewalls with two sided tape is not acceptable.**

8.2.2 Insulation

Insulation of rigid, closed cell polystyrene or bagged fiberglass shall be provided for the full depth of the structure between all interior and exterior panels and any cavity between the subfloor and floor constructions.

Bidders shall specify the type of insulation with their bid along with evidence that it is flame retardant and non-toxic. It is recommended that the vendor submit product description, warranty information, and product literature.

8.2.3 Firewall

A firewall shall separate the engine and passenger compartments, providing both thermal and acoustic insulation, sealing against intrusion of exhaust gases into the vehicle and providing sufficient sound attenuation to maintain a maximum 86db level in the passenger compartment. The firewall shall be constructed of flame resistant materials.

8.3 Roof Gutters

Water deflecting roof gutters shall be provided over ambulatory and wheelchair accessible doors, over the passenger windows, and over the driver's windshield where necessary.

8.4 Floor Construction and Covering

8.4.1 Floors shall be constructed of a minimum of five-eighths inch (5/8"), five ply, exterior BC grade (or better) water-resistant plywood without visible cracks or holes firmly secured to the floor structure by the use of adhesive and mechanical fasteners with no intrusions into the bus body compartment. Floor shall be laid in such a manner as to be free from squeaking.

- 8.4.2 All flooring shall be Rubber Solutions, RCA Transit Flooring, or approved equal. Floor covering to be blue and shall contrast with the seat cover colors. **It is recommended that the vendor submit product description, warranty information, and product literature with bid.**
- 8.4.3 All flooring shall be covered with three-sixteenths inch (3/16") textured, slip resistant floor covering. All step edges to be marked in accordance with FTA/ ADA requirements. Each step edge shall have a step tread utilizing one-piece Talon Tread flooring or an approved equal that features yellow contrast nosing.
- 8.4.4 Floor covering shall be laid without gaps or openings. Joints shall be filled with color matching material to be tight against any influx or seepage of water and all edges shall be sealed.
- 8.4.5 Floor covering under seat shall be one-eighth (1/8") inch smooth floor covering.
- 8.4.6 Aisle front entrance and securement areas shall be covered with three-sixteenth (3/16") inch textured, slip resistant floor covering.
- 8.4.7 A standee line is required in the same required yellow as the step nosing.

8.5 Bumpers

The front bumper shall be the OEM chassis supplier's.

The rear bumper shall be unpressurized, self-contained, self-restoring, energy absorbing bumpers of the HELP system, such as the ROMEO RIM, SMI, or approved equal. **It is recommended that the vendor submit product description, warranty information, and product literature with bid.**

8.6 Fenders and Molding

Flexible fenders shall be provided for the rear wheels; **the Division of Public Transit shall approve materials and configuration.** Rubber molding shall run the length of the passenger compartment at floor level. The molding shall be secured in a manner other than snapped onto a metal rail. The ends of the molding shall be finished and caulked if necessary to prevent sharp edges at the angle cuts.

9.0 Doors- Access and Entrance/ Exit

9.1 Access Doors

Access doors shall be provided where necessary to service transmission, engine, radiator, batteries, air-conditioning, and radio system components, if any.

9.2 Ambulatory Passenger Entrance/Exit

Dimensions shall be:

Overall Clear Height	approximately	80 inches
Overall Clear Width	not less than	29 inches
Tread Depth	not less than	9 inches
Riser Height	not to exceed	9 inches
Distance Ground to Step	not to exceed	12 inches

9.2.1 When the entrance is closed, the lower step shall not protrude beyond the door line more than two (2) inches

9.2.2 Brushes and other appropriate seals shall be fitted to the bottom of the door panels to assist in sealing and snow clearance.

- 9.2.3 Electrically operated door to be provided. Door control shall be within twenty-eight (28") inches from the right side of the driver's shoulder. The door frame shall be welded at all seams to ensure that the door frame will not separate. An additional post shall run from the side of the passenger entrance door to the cap to provide an extra support for the front cap.
- 9.2.4 The passenger entrance door frame shall be aluminum or stainless steel construction only.
- 9.2.5 Passenger door shall be key operated from the outside and by a rocker or toggle switch from the driver's console. Door pivot pins shall incorporate permanently lubricated bearings. Door must have an emergency release in case electric is not properly working.
- 9.2.6 Driver's door shall have an aluminum running board for easy access for the driver. The Division of Public transit requests no less than 8.5" wide and within 8" of the ground.

9.3 Non-Ambulatory Passenger Entrance/ Exit

A driver operated, two-piece wheelchair entrance door with large upper viewing window, capable of being locked, shall be located at the rear of the curbside and behind the rear wheels. Doors shall be fitted with heavy-duty, full-length piano hinges. These doors shall not sag when open, and if there is a possibility of sagging, additional preventative gussets need to be inserted.

A minimum clear vertical distance of 59" inches is required through the doorway and lift installation.

Overall door width of approximately 52 inches is required. The door width must provide operating clearance for a lift meeting the requirements of Section 10.

- 9.3.1 A warning light shall be provided at the driver's station to indicate when the door is open for wheelchair operation and a buzzer to indicate when it is ajar with the vehicle in motion.
- 9.3.2 The Division prefers that the door ajar signal is activated by a magnetic proximity switch or a plunger type switch. The striker for the signal must not have contact with flexible section of the door. It must either make contact with the top mullion or have a two (2") inch by two (2") inch striker plate to prevent false alarms as, over time, the pin creates slack in the foam-filled door material..
- 9.3.3 Air springs shall be heavy duty, riveted to body and door or double nut and lock nut. Air springs will firmly secure the door in the open position.

9.4 Emergency Exit Door

A full height rear emergency exit door with a minimum clear opening of thirty-five and a half (35.5") inches by fifty-seven (57") inches minimum that fully complies with ADA standards shall be provided on all floor plans.

Large upper and lower windows shall be provided in the door to maximize rearward visibility.

Emergency exits with full length stainless steel piano style hinge will be required on all floor plans. A camover or spring style holdback to be used to secure door in open position. Pneumatic shock is unacceptable for rear door.

10.0 Wheelchair Lift

10.1 Lift

A Braun Millennium 2 series or approved equal lift with a lifting capacity of 800 lbs shall be provided that fully meets or exceeds ADA requirements. Platform width will be thirty-seven (37") inches minimum and length to be

fifty-one (51") inch minimum. **It is recommended that the vendor submit product description, warranty information, and product literature with bid. Lift must comply with new and or current Federal Regulations.**

10.2 Lift Installation

- 10.2.1 The lift shall be installed by bolting through the floor into structural steel that is an integral part of the body underfloor structure.
- 10.2.2 The power unit shall be placed at the forward side of the lift for rear mounted lifts and on the rear side for forward mounted lifts and be readily accessible for service. In the event of power failure, the deployed lift platform shall be able to be lower manually with passengers and raised without passengers.
- 10.2.3 System control valve shall be solenoid controlled and shall be accessibly mounted for easy maintenance. All lift components shall either be inside the vehicle or enclosed and protected from water wash.
- 10.2.4 Electrical control switches shall be completely weather proof and labeled as to function. All switches shall be of the momentary type.
- 10.2.5 The lift installation shall provide a hand-held switch for remote operation of the lift in addition to or in place of the regular door-mounted electrical lift controls. The lift control cable shall have a protective steel wire cover from control to base of lift, if available.
- 10.2.6 A caution sign shall be prominently displayed in full view of persons standing at curbside of the vehicle as a warning to stand clear for lift operations.
- 10.2.7 An interlock system with fast idle, such as Intermotive Gateway, ILIS, or approved equal, shall be provided which renders the lift inoperative unless the transmission shift lever is in the "Park" position and the emergency brake is applied. **It is recommended that the vendor submit product description, warranty information, and product literature with bid.**
- 10.2.8 Activating the lift circuitry through a lift master switch will cause the rear hazard lights to flash.
- 10.2.9 The lift should feature a belt, like the Access Arize or an approved equal, that connects to the side arms of the lift that will protect the passenger on the lift from rolling off of the lift

11.0 Seating and Securement

A minimum seating capacity as outlined in the general characteristics is required using forward-facing flip seats where necessary in their bids. Seating diagrams shall be provided with bid submittal.

11.1 Passenger Seats

Seats shall be Freedman, American Seating, or an approved equal with an under seat lap belt and contoured configuration. Seats shall be spring base with a minimum of 5 inches of foam padding. Upholstery shall be 3.5 vinyl-fabric hybrid, such as Mor-Care from Freedman or an approved equal, with ABS Knee-Saver back. **It is recommended that the vendor submit product description, warranty information, and product literature with bid.**

Retractable seatbelts shall be provided for each seat and must be attached to the seat frames. Two (2) seat belt extensions must be provided

A grab rail shall be provided on all forward facing seatbacks.

Seats shall use a single T pedestal leg with black painted finish and side rail for mounting.

At least 2 seats shall be equipped with a Freedman Featherweight CRS-225 child safety latch for securement of children's car seats, or an approved equal. If the designated seat is at a wheel well, it can only be on the wall seat.

Standard seats shall conform to the following dimensions:

Width per passenger	18 inches
Height of seat cushion	18 inches above floor
Depth of seat	17 inches maximum
Height of seat back	22 1/2 inches max
Hip-to-Knee room:	27 inches maximum
Aisle width	14 inches minimum

11.1.1 Seats and seating shall comply with the following FMVSS Standards:

Standard Number 207	Seating Systems
Standard Number 208	Occupant Crash Protection
Standard Number 209 and 210	Seat Belt Assemblies and Anchorage

11.1.2 Aisle Width

Seat shall be mounted flush (within 1 inch) against the side wall of the vehicle to allow for a minimum aisle width of 14 inches.

11.2 Driver's Seat

Driver's seat shall be Freedman Sport Shield with a minimum of Level 4 cloth upholstery to match the color of the passenger seats. The seats should also feature height adjustment, if possible. **It is recommended that the vendor submit product description, warranty information, and product literature with bid.**

A fold up armrest will be provided on the right side of the seat.

Seats shall have FMVSS certified seatbelts with retractor attached to the seat frame.

Seats shall have a minimum of three (3) inches fore and aft adjustment and from 15 to 30 degrees recline with positive latching.

Seat installation shall allow for unimpeded movement over the whole seat positioning range as well as the ability to enter and exit the seat to the right side, into the bus.

11.3 Mobility Aid Securement

Each wheelchair will be equipped with an ADA compliant, fully automatic retractable restraint system that has self-tensioning, self-locking tie down belts that are interchangeable and that feature quick-release S-hooks, such as the Lok-It from American Seating, the Sure-Lok Titan Retractor System, Q'Straint, or an approved equal. The positions shall be located preferably ten (10") inches but no less than 4" from one another and not share tie down tracking. **It is recommended that the vendor submit product description, warranty information, and product literature with bid.**

Heavy-Duty Series L Track with flanges, mounting holes, and clear, anodized finish to be used, like FE-748-100-PD4C track with end caps, or an approved equal. The seams between the flooring and the track need to be treated to ensure that no moisture can get to the track to cause track deterioration.

A convenient, secure, and rattle free installation shall be provided. **Proposed installation location to be approved by the Division of Public Transit. Bidder shall supply full details of the proposed securement system with bid submittal.**

Vendor will include four (4)-sixteen inch (16") quick straps or approved equal for each securement location.

A storage pouch capable of holding the wheelchair retractors will be installed adjacent to the securement locations for storage of associated belts and accessories, if needed.

- The wheelchair retractors shall be fully automatic, auto-locking, and self-tensioning.

- The retractors shall remove any slack in the webbing after they are secured to the wheelchair.
- The retractors are self-retracting; therefore, no belts are left on the floor, keeping them cleaner and longer lasting.
- The retractor shall have a “LOCKED” indicator tag and shall only be visible when the retractor is in the locked mode, assuring that the retractor is not in the release mode when properly secured to the wheelchair.
- The retractors shall be heavy duty with heat treated structural components and plated for superior corrosion resistance.
- The retractors shall have a chrome plated metal cover for long lasting protection.
- The retractors shall have blue webbing and the occupant restraints shall be of a contrasting color for easy identification in the field.
- The retractors shall be designed to be low-profile to fit under most wheelchair footrests.
- The retractors shall be equipped with anchoring points for the attachment of the occupant restraint lap belts.
- The retractors shall be used in a variety of shoulder/lap belt combinations.
- The retractors shall have manual knobs for additional tightening, if needed.
- The retractor operator shall be able to secure a wheelchair with one hand in as little as 10 seconds.
- The retractor shall have a warranty period of three (3) years and shall have a manufacturing label to identify the part number and date of manufacture for easy traceability.
- The retractors, occupant restraints, and anchoring equipment shall be installed in accordance with the manufacture’s installation instructions and recommendations.
- The retractors and occupant restraints shall meet or exceed, but not be limited to, the following specifications: 30 mph/20g Impact Test Criteria per SAE J2249; ISO 10542; Canadian Z605; national Standards for School Buses; ADA n(49 CFR Part 38); FMVSS 209, 222, and 302.

11.4 Passenger Assists

Passenger assists shall be constructed of seamless stainless steel tubular stock having an outside diameter of between 1.25 inches and 1.5 inches and shall be provided as specified below on all including Option I Non-accessible vehicle.

Assists shall be securely installed to prevent the passengers from moving or twisting the assists when grasped.

- 11.4.1 Assists shall be installed as inclined hand rails 30 inches above the step treads on both sides of the passenger step well.
- 11.4.2 Passenger assists shall be provided as floor-to-ceiling vertical stanchions at the top of the steps at both sides of the step well and shall be fully padded above seat level.
- 11.4.3 Passenger assists shall be provided as over head assists on both sides of and parallel to the center aisle for the full-length of the passenger compartment except where they will substantially interfere with wheelchair operations.
- 11.4.4 Passenger assists shall be provided as vertical stanchions, padded above seat level, elsewhere within the vehicle, including the driver’s barrier (see 11.6) and behind the rearmost passenger seats.
- 11.4.5 All stanchions shall have rubber fittings at top and bottom where the tube inserts into the anchor to provide more stability and vibratory wear resistance.

11.5 Modesty Panels

Sturdy modesty panels constructed of padded material complementing the interior trim shall be provided ahead of the forward row of seats on both sides of the aisle.

A full-height 3/8” LEXAN translucent barrier shall be provided behind the driver’s seat and above the modesty panel. **Modesty panel installation must be approved by the Division of Public Transit.**

12.0 Glazing

All glazing material shall meet federal safety requirements.

12.1 Windshield

Windshield shall be OEM tinted.

12.2 Passenger Windows

Windows shall be a top mounted T slider with at least one curbside and two street side points of hinged emergency egress. Emergency exits are to be denoted with fade and peel resistant decals. Cling and peel decals are not acceptable.

Size shall be approximately thirty-six (36") inches wide by thirty-six (36") inches high, or approved equal, with one-eighth (1/8") inch AS-3 tempered glass tinted for 31 percent transmittance.

12.3 Passenger Door

Door panels shall have full height AS-2 tempered glass windows for maximum visibility of the curb.

12.4 Transition Windows

The transition panel between the passenger door and the front fender shall have a window of approximately 34 inches by 10 inches dimensions to enhance the view of the curb area.

12.5 Lift Door Windows

Lift doors shall incorporate a single large window in each door panel consistent with the other passenger windows. Door shall be two-piece as is specified in section 9.3.

12.6 Rear Windows

In addition to the windows in the rear emergency door, windows shall be provided on both sides of the door to increase rearward visibility.

13.0 Mirrors and Sun Visor

13.1 Exterior: Two (2) six and one-half inch (6 ½") by nine and one-half inch (9 ½") minimum size fully adjustable outside rear-view mirrors, such as the Rosco model number 715H for Driver's side and 717H for passenger side, or approved equal, shall be provided: one at the driver's door and one at the right front body corner. Mirror arms shall be constructed on anodized aluminum, stainless steel, powder coated steel, or another non-corrosive, approved equal material. Mirror arm may be chrome plated. Convex "blind spot" mirrors shall also be provided on each side of the vehicle, with a minimum five inch (5") diameter. The convex mirror shall be built into the same head as the flat mirror and shall not be of the stick on type. Both mirrors shall be reinforced mounted breakaway mirrors. Bolts shall be of the heaviest grade to ensure the bolts from breaking or snapping. Mirrors shall be heated and remote controlled, such as those produced by Rosco, Lucerix, or approved equal, and shall be heated and remote controlled. **It is recommended that the vendor submit product description, warranty information, and product literature with bid.**

13.2 Interior: A six inch (6") by sixteen inch (16") minimum rectangular rear view mirror shall be installed that provides a complete view of the interior to the driver.

13.3 Rear View Mirror

The OEM's rear view mirror shall be retained.

13.4 Sunvisor

A driver's sun visor shall be provided that is able to pivot to cover the driver's door window.

13.5 Fresnel Lens

Each vehicle shall be equipped with a flat, wide-range, Fresnel lens, approximately eleven inches (11") by fourteen inches (14"), ready for installation/placement by the purchaser upon delivery of the vehicle.

14.0 Windshield Wipers

Windshield wipers shall be heavy-duty, three-speed automatic (intermittent, low, and high) wipers that are controlled by the driver.

15.0 Mud Flaps

Rubber mud flaps shall be provided on all wheels.

16.0 AM/FM CD Clock Radio

Vehicle shall be equipped with the OEM's deluxe digital radio stereo with CD and a 4 speaker system for the passengers. Deluxe aftermarket radio manufactured by Panasonic with CD feature is an approved equal. At least one (1) additional speaker shall be installed in the driver's door or driver's side of the dashboard. **It is recommended that the vendor submit product description, warranty information, and product literature with bid.**

17.0 Storage Compartment

A storage compartment capable of accommodating jumper cables, seatbelt cutter, and other items shall be provided in the front header above the driver. The compartment will be provided with a latch or other mechanism to hold it in the closed position.

Bottom hinged compartment doors will be provided with restraint straps to limit its movement to 90 degrees. Top hinged doors will be provided with a latching mechanism to hold door in upright position when open. **The Division of Public transit must approve location and size.**

Tuffy storage boxes are accepted as an approved equal when other selected options restrict available space as specified. **The Division of Public transit must approve location and size.**

18.0 Emergency/ Safety Equipment

First Aid Kit: First aid kit shall comply with Federal Motor Vehicle Carrier Safety Regulations Part 393(h), Section 393, Part 96 (c) with a minimum of 15 units. First aid kits shall be mounted so as to provide for easy access in the event of an accident, away from foot traffic.

Kits shall be housed in a plastic or metal box, which contains at least the following items:

- Instant Cold Pack (1)
- Certacaine Burn Spray (at least 1 oz.)
- 1" x 3" Adhesive Bandages (25)
- ¾" x 3" Adhesive Bandages (10)
- Extra Large Adhesive Bandages (10)
- 3" x 3" Gauze pads (10)
- Antiseptic Wipes (10)
- Alcohol Prep Pads (20)
- Ammonia Inhalants (10)
- 2" x 6 yards Gauze Bandage
- ½" x 2.5 yards Adhesive Tape
- Burn Ointment (1/8 oz.) (4)
- Insect Sting Swabs (4)

PVP Iodine Swabs (4)
 Tweezers (1)
 Scissors
 Safety Pins (5)

Fire Extinguisher: A 5 lb. dry chemical fire extinguisher with a minimum of 20-A: 180-B:C rating shall be provided in vehicle and shall be mounted in an access compartment with a hinged door or on a vehicular-type, quick access bracket, away from foot traffic.

Reflectors: Three bi-directional emergency reflective triangles conforming to requirements of FMVSS No. 125, Section 571.125 shall be secured in the storage compartment of the vehicle.

Bloodborne Pathogen Protection Kit: A 10 unit minimum kit housed in a polypropylene or metal box and containing at least the following:

Gown/ Cap (1)
 Goggles/ Eye Shield (1)
 Mask (1)
 Set of Gloves (3)
 Infectious Liquid Control Powder (2 oz.)
 Scraper (1)
 Red Biohazard Bags with Ties (2)
 Crepe Towels (2)
 Antiseptic Towelettes (4)
 Disinfectant Towelettes (4)
 Mouth to Mouth Barrier (1)
 Scoop Bag (3)

Web Cutter: A Sure-Lok premium #8705 or approved equal shall be secured in the storage compartment of the vehicle.

Two Blankets: Two (2) folded, sealed and stored silver Mylar disposable rescue blankets by Certified Safety Manufacturing or an approved equal.

The Division of Public Transit will designate the location of the emergency equipment.

19.0 Painting and Finishing

19.1 Interior

Ceiling and side panels shall match the interior color scheme and provide a hard, vandal resistant, flame retardant surface. **Available interior paint and trim schemes shall be provided by the bidder for review and selection by the Division of Public Transit with the bid.**

19.2 Exterior

19.2.1 Paint

Surfaces shall be properly cleaned and primed, as appropriate, for the paint used. All exterior surfaces shall be impervious to gasoline and commercial cleaning agents. The exterior of each coach shall be painted a basic white or light cream color as furnished by the chassis manufacturer. Fiberglass matching the color of the chassis is acceptable.

19.2.2 Paint Scheme

Paint schemes and paint colors of the agencies receiving the vehicles will be furnished by the successful vendor.

Each agency will have a logo and striping scheme. Each agency's logo and striping scheme will have at least 2-3 colors, with the possibility of up to 5 colors.

The vendor shall stripe the vehicle with exterior reflective vinyl tape meeting DOT-C2 standards that match the agency's logo and striping scheme.

When reflective tape and paint are used for the same color on one vehicle, they must match (example: painting the bus skirt and using tape stripes for the side of the vehicle must match.) Vendor shall supply sample of exterior vinyl and chart to be used for logo and striping of vehicle.

19.3 Signage

The following internal and external signage is required. Lettering to be Helvetica medium. Numbers to be four (4") inches unless otherwise specified for external signage. **Full details of size and location will be agreed upon between the Division of Public Transit and the successful bidder.**

19.3.1 Interior Decals:

- "No Smoking" sign shall be installed on the driver modesty panel
- "All passengers are required to wear seat belts when vehicle is in motion" sign shall be installed on the driver modesty panel.
- "Clearance __feet__inches" above driver's visor. (These specific figures on clearance will be determined by exact dimensions of vehicle.)
- A sign that displays
 - "Emergency Telephone Numbers:
 - Police:
 - Ambulance:
 - Fire:
 - Transportation System:"
- "Emergency Equipment" sign shall be applied to the storage compartment above the driver's seat.
- "Priority Seating" decal shall be supplied for the first two, forward-facing fixed seats on both sides.

19.3.2 Exterior Decals:

- "This vehicle makes frequent stops" decal applied to the backdoor
- The International Wheelchair Accessibility symbol on the back of the bus.
- "West Virginia Transit Assistance Program" paint scheme may be required on the exterior of the vehicle (see 19.2.2). Example of stripes and signage in Part 6.
- "CAUTION: LOADING AND UNLOADING PASSENGERS"
- "THIS VEHICLE STOPS AT ALL RAILROAD CROSSINGS"
- Black lettering on yellow background "Watch Your Step" decals are to be affixed to entrance step risers.

19.3.3 Exterior Reflective Vinyl Tape

The vehicle shall be striped with exterior white reflective vinyl tape at the top and bottom of all egress passenger windows, meeting DOT-C2 standards.

Finished surfaces shall not be damaged by controlled applications of commonly used graffiti-removing chemicals.

Using the white reflective vinyl, the successful bidder must circle one window on each side, and have one strip running from the front of the bus to the rear. Because some of the existing logos are not on the rear of

the bus, the white reflective vinyl must circle the rear emergency door window, even when the color vinyl is used in the logo.

19.4 Undercoating and Rustproofing

The vehicle shall be fully undercoated at the point of manufacture before delivery. Symtech, Tectyl, Z Tech, or Pearl Guard are suggested applications. **A complete description of the application is to be provided in bid submittal.**

19.5 Manuals

At the time of vehicle delivery, the contractor shall supply one set of the following manuals:

- One (1) chassis operator's manual per vehicle
- One (1) bus body operator's manual per vehicle
- One (1) chassis service manual per transit authority or one (1) per agency
- One (1) chassis parts manual per transit authority or one (1) per agency
- One (1) vehicle body service manual per transit authority or one (1) per agency
- One (1) vehicle body parts manual per transit authority or one (1) per agency
- One (1) set of wiring schematics of auxiliary circuits per transit authority or one (1) per agency
- One (1) copies of any other necessary printed materials/instructions needed for the maintenance of the vehicle.

19.6 Miscellaneous Requirements

The vendor shall furnish the following in addition to OR to supersede any previous requirements

- Two (2) bulkhead mounted document protectors, eight and one-half inches by eleven inches (8.5" by 11") for display of route information or system announcements.
- Interior advertisement racks mounted on both sides of the inner roof liner
- Exceeds ADA wheelchair lift is required. This lift is generation 2 since the new FMVS standards went into effect. It has a platform dimension of thirty-seven inches wide by fifty-one inches long (37" x 51"). The previous lifts were 34" wide. Note: The capacity is still 800 pounds. ADA currently requires 600 pounds.
- The wheelchair door required to facilitate the installation of the required lift is (fifty-two inches) 52".

OPTIONAL EQUIPMENT

The following shall be bid as options:

OPTION A: NON-ACCESSIBLE VEHICLE

A vehicle having at least 12 fixed forward facing seats (doubles/singles). High back seating required at rear row per section 11.1. **The Division of Public Transit shall approve the proposed seating configuration.**

OPTION B: FIXED ROUTE PACKAGE

This package will contain front and side digital destination signs, Passenger Signaling System, PA system, farebox provision and strobe light as described below.

Front and side digital destination signs shall be provided. A lightweight all LED sign that provided a wide viewing angle for visibility at day or night with automatic brightness adjustment. Signs must be compatible with Windows 95/98/2000/XP or NT programming platform for easy transit system use. The signs must come with all accessories in order for the transit systems to change routes daily if needed, including an operator control unit (OCU) with PC card port for uploading data will be required for each bus along with a 12V DC converter. The destination signs must meet all ADA standards and must have a minimum operating life of 100,000 hours. The sign shall be fastened to the body of the vehicle on the top and bottom of each destination sign to secure and eliminate all movement. Brackets should be used in addition to normal installation procedures to secure signs at the top and bottom. **The Division of Public Transit shall approve size and location of windows. Vendor**

shall supply description product description, warranty information, and product literature with bid. Twinvision or approved equal shall be supplied.

Dimensions: front- All LED 14 x 108 small pitch signs. Side – All LED 14 x 72. All programmable software and hardware is to be provided. Customer support shall be provided.

Control panel for the signs shall be located at a position convenient for driver operation and shall be approved by the Division of Public Transit. Vendor shall submit details with bid.

Passenger signaling system with a pull cord stop request system and touch tape with buzzer at wheelchair positions shall be provided. Vendor shall submit product description, warranty information, and product literature with bid. The pull cord system shall be at height that individuals with disabilities can access the cord at seat level front to rear. Mobile PA system with a handheld mic, one external speaker, and two internal speakers shall be provided. PA system may be integrated into the radio system if it can be done without excessive splicing; otherwise, the systems should be separate.

Vendor shall submit product description, warranty information, and product literature with bid.

Farebox provisions require that the forward stanchion at the driver's shoulder shall be prewired for mounting of fare box with enough slack for the positioning of the fare box to be moved.

A protected or guarded clear lens strobe light shall be installed on top of the vehicle. The Division of Public transit shall approve the type, the installation location, and the process. Vendor shall submit product description, warranty information, and product literature with bid.

OPTION C: PARATRANSIT PACKAGE-include credit to delete maintenance manuals

One set of Tire Traction Chains of the appropriate size shall be provided for each vehicle. Chains will be secured in the vehicle at a location approved by the Division of Public Transit.

Jumper cables of stranded copper, 4-6 gauge, and seven (7) feet minimum length shall be secured in the storage compartment of the vehicle.

One set of Vehicle Jack and Lug Wrench of the appropriate size to be provided per vehicle in a safe and secure location.

OPTION D: REPEL CLOTH PASSENGER SEATS

Passenger seats shall be covered with commercial grade, heavy duty level 4 cloth material. All other seating requirements in Section 11 must be met. Cloth shall be repel fabric (water resistant), which is antimicrobial and antibacterial, such as that provided by Freedman Seating Company or approved equal. It is recommended that the vendor submit product description, warranty information, and product literature with bid.

OPTION E: FLIP UP ARMREST FOR PASSENGER SEATS

A flip up armrest for each passenger aisle seat shall be installed. Vendor shall submit product description, warranty information, and product literature with bid.

OPTION F: EXTENDED BODY LENGTH WITH FRONT LIFT OPTION

Extended length with front lift option; Increase body length to 284" +/- and mount on 158/159" wheelbase chassis to accommodate front lift configuration and additional wheelchair position per attached floor plan.

OPTION G: CHILD RESTRAINT SEAT

This option is to upgrade one double mid-high to a double Integrated Child Restraint Seat (ICS) which is capable of securing a child between the heights of 33" and 49" with weight between 20 and 60 pounds. Instructions for the securement shall be printed on the seat and shall be easy to understand. Vendor shall submit product description, warranty information, and product literature with bid.

OPTION H: TRAFFIC ALERT SIGN

A safety amber LED alert traffic sign design when brake is pressed to alert rear on coming traffic that vehicle is stopping. The sign will display CAUTION STOPPING only. Transpec Model # 7500 or approved equal. Vendor shall submit product description, warranty information, and product literature with bid.

OPTION I: SECURITY CAMERA SYSTEM

Provide and install REI Bus watch system, or approved equal, with DBW 4-320g hard drive, seat mounted security box with keys and four (4) color dome cameras per bus. Locations of cameras to be selected by the Division of Public Transit.

OPTION J: SECURITY CAMERA PLAYBACK SYSTEM

Provide an REI BusWatch playback system, or approved equal, with 2 extra 320g hard drives

OPTION K: FULL BUS BODY PAINT

The vendor shall supply A full-bus body paint for each vehicle ordered. Vendor must supply a sample paint chart with bid.

The West Virginia Division of Public Transit will select the colors for each vehicle to be painted.

OPTION L: THREE QUARTER BODY PAINT WITH EXPANDED GRAPHICS

The vendor shall supply three-quarter bus body paint for each vehicle ordered. Vendor must supply a sample paint chart with bid. The West Virginia Division of Public Transit will select the colors for each vehicle to be painted.

OPTION M: VEHICLE SKIRT PAINTING

The body skirt and chassis's low cab of vehicle shall be painted. The West Virginia Division of Public Transit will select the colors for each vehicle to be painted.

OPTION N: FAREBOXES FOR VEHICLES

Fare box with cabinet, (2) two money vaults, a set of keys for each with locking system. A separate price for each of the following types of fare boxes to be provided: Diamond Model #XV, E-5, and Main Fare Box # M-4.

OPTION O: TALKING BUS

Talking Bus by Digital recorders to be ordered in conjunction with fixed route package.

OPTION P: VISTA-TYPE LIFT

Option to substitute Vista type lift for the Century type lift.

OPTION Q: ONLINE INSPECTION SERVICES

Option for vendor to secure additional independent inspection services in the event that this service is needed to fulfill the terms of the contract.

OPTION R: SHOULDER BELTS

Option to include shoulder belts at every seat.

PART 3 WARRANTY

1.0 WARRANTIES

The Vendor has an obligation to ensure that the entire vehicle is covered by a warranty. The Vendor shall make every effort to assure that all obligations defined under all warranties applicable to the vehicle or any subpart of the vehicle are fulfilled.

2.0 WARRANTY REQUIREMENTS

Warranties in this document are in addition to any statutory remedies or warranties imposed on the Vendor. Consistent with this requirement the Vendor warrants and guarantees to the Division of Public Transit each complete vehicle, and specific subsystems and components as follows:

2.1 Complete Vehicle

The vehicle is warranted and guaranteed to be free from defects and related defects for three (3) years or 36,000 miles, whichever comes first, beginning on the first day after the date of final acceptance of each vehicle. During this warranty period, the vehicle shall maintain its structural and functional integrity. The warranty is based on regular operation of the vehicle under the operating conditions prevailing in the Recipient Agency's(ies) locale(s).

2.2 Warranty of Basic Vehicle Structure

The Vendor shall warranty the frame and suspension members for three (3) years or 36,000 miles, whichever comes first. This warranty shall not cover air bags, leveling valves, springs or other normal wearing parts. The Vendor is not liable for warranty if the Recipient Agency(ies) voids the warranty as outlined in Section 3.0 of this Part. If the frame or suspension fails or shows indication of imminent failure, the Recipient Agency(ies) will immediately notify the Vendor of said defect. Within ten (10) calendar days the Vendor will inform the Recipient Agency(ies) on how the Vendor will repair the vehicle. Repair of frame and suspension failures will be the responsibility of the Vendor. Within fifteen (15) calendar days from notification of the defect the Vendor shall begin the repair of the frame and suspension defects. If the vehicle with the reported frame and suspension defect is out of revenue service for more than twenty (20) calendar days because of the reported defect, the Vendor will have to either provide a substitute vehicle of equal seating capacity with wheelchair lift (if applicable) of the same age or newer than the vehicle with the defect or directly reimburse the Recipient Agency(ies) the cost of leasing a substitute vehicle. The maximum daily reimbursement will be \$300. The Vendor will have to continue to provide a substitute vehicle or reimburse the Recipient Agency(ies) until the defect is completely repaired.

2.2.1 Warranty Locations

A description of how and by whom warranty service is to be provided in four (4) areas of West Virginia is to be included in the bid proposal. The information should cover both mechanical and body work. All bidders shall provide vendors who will do the warranty of both chassis and body, including bus body, air conditioning and wheelchair lifts. The four warranty service areas of West Virginia include: The Northern Panhandle, Eastern Panhandle, Central West Virginia and Southern West Virginia.

2.3 Subsystems and Components

The subsystems and components are warranted and guaranteed to be free from defects and related defects as follows:

ENGINE:	Three (3) years or 36,000 miles, whichever comes first.
TRANSMISSION:	Three (3) years or 36,000 miles, whichever comes first.
DRIVE AXLE:	Three (3) years or 36,000

miles, whichever comes first.

BRAKE SYSTEM: Excluding friction material,
Three (3) years or 36,000 miles
whichever comes first.

**BASIC BODY
STRUCTURE
INTEGRITY:** Three (3) years or 36,000
miles, whichever comes first.

**AIR CONDITIONING
SYSTEM:** Two (2) years or two (2)
operating seasons, whichever is
greater.

**WHEELCHAIR
LIFT SYSTEM:** Two (2) years.

ALL ADD ON COMPONENTS: Two (2) years, unlimited miles.

3.0 VOIDING OF WARRANTY

The warranty shall not apply to any part or component of the vehicle that has been subject to misuse, negligence, accident, or that has been repaired or altered in any way so as to affect adversely its performance or reliability, except insofar as such repairs were in accordance with the Vendor's maintenance manuals and the workmanship was in accordance with recognized standards of the industry. The warranty shall also be void if the Recipient Agency(ies) fails to conduct normal inspections and scheduled preventative maintenance procedures as recommended in the Vendor's maintenance manuals.

4.0 EXCEPTIONS TO WARRANTY

The warranty shall not apply to scheduled maintenance items, and items such as tires and tubes, nor to items furnished by the Recipient Agency(ies) such as radios, fareboxes and other auxiliary equipment, except insofar as such equipment may be damaged by the failure of a part or component for which the Vendor is responsible.

5.0 DETECTION OF DEFECTS

If the Recipient Agency detects a defect within the warranty periods defined in Section 2.0 of this Part, it shall promptly notify the Vendor's representative five (5) working days after receipt of notification, the Vendor's representative shall either agree that the defect is in fact covered by warranty, or reserve judgment until the subsystem or component is inspected by the Vendor's representative or is removed and examined at the Recipient Agency's(ies) property or at the Vendor's plant. At that time, the status of warranty coverage on the subsystem or component shall be mutually resolved between the Recipient Agency and the Vendor. Work necessary to effect the repairs defined in Section 8.0 of this Part shall commence within ten (10) working days after receipt of notification by the Vendor.

6.0 SCOPE OF WARRANTY REPAIRS

When warranty repairs are required, the Recipient Agency(ies) and the Vendor's representative shall agree within five (5) days after notification on the most appropriate course for the repairs and the exact scope of the repairs to be performed under the warranty. If no agreement is obtained within the five (5) day period, the Recipient Agency(ies) reserves the right to commence the repairs in accordance with Section 8.0.

7.0 FLEET DEFECTS

A fleet defect shall be defined as the failure of any identical items covered by the warranty and the specifications herein, and occurring in a twenty percent (20%) portion of the vehicles purchased under this contract.

The Vendor shall correct a fleet defect under the warranty provision. After correcting defect, the Vendor shall promptly undertake and complete a work program reasonably designed to prevent the occurrence of the same defect in all other vehicles purchased under this contract. The work program shall include inspection and/or correction of the potential or defective parts in all of the vehicles purchased under this contract. The warranty on items determined to be fleet defects shall be extended for the time and/or miles of the original warranty. This extended warranty shall begin on the date of the repair/ replacement for the corrected item.

8.0 REPAIR PROCEDURES

8.1 Repair Performance

At its option, the Division of Public Transit, or its designated representative, may require the Vendor, or its designated representative, to perform warranty covered repairs that are clearly beyond the scope of Recipient Agency's(ies)' capabilities. All warranty work done by Recipient Agency(ies) personnel will be reimbursed by the Vendor.

8.2 Repairs by Vendor

If the Recipient Agency(ies) requires the Vendor to perform warranty covered repairs, the Vendor's representative must begin the work necessary to make repairs, within ten (10) working days after receiving notification of a defect from the Recipient Agency(ies). The Recipient Agency(ies) shall make the vehicle available to complete repairs timely with the Vendor's repair schedule.

The Vendor will provide, at its own expense, all spare parts, tools and space required to complete repairs. At the Recipient Agency's(ies)' option, the Vendor may be required to complete repairs. At Recipient Agency's(ies)' option, the Vendor may be required to remove the vehicle from Recipient Agency's(ies)' property while repairs are being effected. If the vehicle is removed from Recipient Agency's(ies)' property, repair procedures must be diligently pursued by the Vendor's representative.

8.3 Repairs by Recipient Agency(ies)

8.3.1 Parts Used

If the Recipient Agency(ies) performs the warranty covered repairs, it shall correct or repair the defect and any related defects using Vendor specified spare parts available from its own stock or those supplied by the Vendor specifically for this repair. Monthly, or at a period to be mutually agreed upon, reports of all repairs covered by this warranty shall be submitted by the Recipient Agency(ies) to the Vendor for reimbursement or replacement of parts. The Vendor shall provide forms for these reports.

8.3.2 Vendor Supplied Parts

The Recipient Agency(ies) may request that the Vendor supply new parts for warranty covered repairs being performed by the Recipient Agency(ies). These parts shall be shipped prepaid to the Recipient Agency(ies) from any source selected by the Vendor within 10 (ten) working days of receipt of the request for said parts.

8.3.3 Defective Components Return

The Vendor may request that parts covered by the warranty be returned to the manufacturing plant. The total cost for this action shall be paid by the Vendor. Materials should be returned in accordance with Vendor's instructions.

8.3.4 Reimbursement for Labor

The Recipient Agency(ies) shall be reimbursed by the Vendor for labor. The amount shall be determined by multiplying the number of man-hours actually required to correct the defect by the current per hour, straight wage rate, plus 53 percent fringe benefits, plus the cost of towing in the vehicle if such action was necessary and if the vehicle was in the normal

service area.

These wage and fringe benefit rates shall not exceed the rates in effect in the Recipient Agency(ies) service garage at the time the defect correction is made.

8.3.5 Reimbursement for Parts

The Recipient Agency(ies) shall be reimbursed by the Vendor for defective parts and for parts that must be replaced to correct the defect. The reimbursement shall be at the invoice cost of the part(s) at the time of repair and shall include taxes where applicable and 10 percent handling costs.

9.0 WARRANTY AFTER REPLACEMENT/REPAIRS

If any component, unit, or subsystem is rebuilt or replaced by the Vendor or by the Recipient Agency's(ies) personnel, with the concurrence of the Vendor, the subsystem shall have the unexpired warranty period of the original subsystem.

PART 4 THE VENDOR'S IN-PLANT QUALITY ASSURANCE REQUIREMENTS**1.0 QUALITY ASSURANCE ORGANIZATION**

The Vendor shall establish and maintain an effective quality assurance organization. It shall be a specifically defined organization and should respond directly to the Vendor's management. The Vendor's complete quality assurance program for purchased components and in-plant inspection procedures shall be available for review by the Division of Public Transit prior to award.

1.1 Control

The quality assurance organization shall exercise quality control over all phases of production from initiation of design through manufacture and preparation for delivery. The organization shall also control the quality of supplied articles.

1.2 Authority and Responsibility

The quality assurance organization shall have the authority and responsibility for reliability, quality control, inspection planning, establishment of the quality control system, and acceptance/rejection of materials and manufactured articles in the production of the vehicles.

2.0 QUALITY ASSURANCE ORGANIZATION FUNCTIONS

The quality assurance organization shall include the following minimum functions.

2.1 Work Instructions

The quality assurance organization shall verify inspection operation instructions to ascertain that the manufactured product meets all prescribed requirements.

2.2 Records Maintenance

The quality assurance organization shall maintain and use records and data essential to the effective operation of its program. These records and data shall be available for review by the resident inspectors. Inspection and test records for this procurement shall be available for a minimum of one (1) year after inspections and test are completed.

2.3 Corrective Actions

The quality assurance organization shall detect and promptly assure correction of any condition that may result in the production of defective vehicles. These conditions may occur in designs, purchases, manufacture, tests, or operations that culminate in defective supplies, facilities, technical data, or standards.

3.0 STANDARDS AND FACILITIES**3.1 Configuration Control**

The Vendor shall maintain drawings and other documentation that completely describe a quality vehicle that meets all of the options and special requirements of this procurement. The quality assurance organization shall verify that each vehicle is manufactured in accordance with these controlled drawings and documentation.

3.2 Measuring and Testing Facilities

The Vendor shall provide and maintain the necessary gauges and other measuring and testing devices for use by the quality assurance organization to verify that the vehicles conform to all specification requirements. These devices shall be calibrated at established periods against certified measurement standards that have known valid relationships to national standards.

3.3 Production Tooling as Media of Inspection

When production jigs, fixtures, tooling masters patterns, and other devices are used as media of inspection, they shall be proved for accuracy at formally established intervals and adjusted, replaced, or repaired as required to maintain quality.

3.4 Equipment Use By Division of Public Transit's Inspector(s)

The Vendor's gauges and other measuring and testing devices shall be made available for use by the Division of Public Transit's inspector(s) to verify that the vehicles conform to all specification requirements. If necessary, the Vendor's personnel shall be made available to operate the devices and to verify their condition and accuracy.

4.0 CONTROL OF PURCHASES

The Vendor shall maintain quality control of purchases.

4.1 Supplier Control

The Vendor shall require that each supplier maintains a quality control program for the services and supplies that it provides. The Vendor's quality assurance organization shall inspect and test materials provided by suppliers for conformance to specification requirements. Materials that have been inspected, tested, and approved shall be identified as acceptable to the point of use in the manufacturing or assembly processes. Controls shall be established to prevent inadvertent use of non-conforming materials.

4.2 Purchasing Data

The Vendor shall verify that all applicable specification requirements are properly included or referenced in purchases of articles to be used on vehicles.

5.0 MANUFACTURING CONTROL

The Vendor shall ensure that all basic production operations, as well as all other processing and fabricating, are performed under controlled conditions, establishment of these controlled conditions shall be based on the documented work instructions, adequate production equipment, and special working environments if necessary.

5.1 Completed Items

A system for final inspection and test of completed vehicles shall be provided by the quality assurance organization. It shall measure the overall quality of each completed vehicle.

5.2 Non-conforming Materials

The quality assurance organization shall monitor the Vendor's system for controlling non-conforming materials. The system shall include procedures for identification, segregation, and disposition.

5.3 Statistical Techniques

Statistical analysis, tests, and other quality control procedures may be used when appropriate in the quality assurance processes.

5.4 Inspection Status

A system shall be maintained by the quality assurance organization for identifying the inspection status of components and completed vehicles. Identification may include cards, tags, or other normal quality control devices.

6.0 INSPECTION SYSTEM

The quality assurance organization shall establish, maintain, and periodically audit a fully documented inspection system. The system shall prescribe inspection and test of materials, work in progress and completed articles. At a minimum, it shall include the following controls.

6.1 Inspection Stations

Inspection stations shall be at the best locations to provide for the work content and characteristics to be inspected. Stations shall provide the facilities and equipment to inspect structural, electrical, hydraulic, and other components and assemblies for compliance with the design requirements.

Stations shall also be at the best locations to inspect or test characteristics before they are concealed by subsequent fabrication or assembly operations. These locations shall minimally include, as practicable, underbody structure completion, body framing completion, body prior to paint preparation, water test before interior trim and insulation installation, engine installation completion, underbody dress-up and completion, vehicle prior to final paint touch up, vehicle prior to road test, and vehicle final road test completion.

6.2 Inspection Personnel

Sufficiently trained inspectors shall be used to ensure that all materials, components, and assemblies are inspected for conformance with the qualified vehicle design.

6.3 Inspection Records

Acceptance, rework, or rejection identification shall be attached to inspected articles. Articles that have been accepted as a result of approved materials review actions shall be identified. Articles that have been reworked to specified drawing configurations shall not require special identification. Articles rejected as unsuitable or scrap shall be plainly marked and controlled to prevent installation on the vehicle. Articles that become obsolete as a result of engineering changes for other actions shall be controlled to prevent unauthorized assembly or installation. Unusable articles shall be isolated and then scrapped.

Discrepancies noted by the Vendor or Division of Public Transit's inspector during assembly shall be entered by the inspection personnel on a record that accompanies the major component, subassembly, or vehicle from start of assembly through final inspection. Actions shall be taken to correct discrepancies or deficiencies in the manufacturing processes, procedures, or other conditions that cause articles to be in nonconformity with the requirements of the contract specifications. The inspection personnel shall verify the corrective actions and mark the discrepancy record. If discrepancies cannot be corrected by replacing the non-conforming materials, the Division of Public Transit shall approve the modification, repair, or method of correction to the extent that the contract specifications are affected.

6.4 Quality Assurance Audits

The quality assurance organization shall establish and maintain a quality control audit program. Records of this program shall be subject to review by the Division of Public Transit.

6.5 Division of Public Transit's Inspector(s)

The Division of Public Transit may be represented at the Vendor's plant by their inspectors, they shall monitor, in the Vendor's plant, the manufacture of vehicles built under this procurement. The Division of Public Transit's inspectors shall be authorized to release the vehicles for delivery. Upon request to the quality assurance supervisor, inspectors shall have access to the Vendor's quality assurance files related to this procurement. These files shall include drawings, material standards, parts lists, inspection processing and reports, and records of defects. The presence of these inspectors in the plant shall not relieve the Vendor of its responsibility to meet all of the requirements of this procurement.

The Division of Public Transit's inspectors shall not have the authority to stop the Vendor's production line until any apparent problem area of major significance that arises to warrant such actions is fully discussed with the Vendor's top management.

7.0 ACCEPTANCE TESTS

7.1 Responsibility

Fully-documented tests shall be conducted on each production vehicle following manufacture to determine its acceptance to the Division of Public Transit. These acceptance tests shall include pre-delivery inspections and testing by the Division of Public Transit after the vehicles have been delivered.

7.2 Pre-Delivery Tests

The Vendor shall conduct acceptance tests at its plant on each vehicle following completion of manufacture and before delivery to the Division of Public Transit. These pre-delivery tests shall include visual and measured inspections, as well as testing the total vehicle operation. The tests shall be documented. Additional tests may be conducted at the Vendor's discretion to ensure that the completed vehicles have attained the desired quality and have met the requirements of Part 2: Technical Specifications. This additional testing shall be recorded on appropriate test forms provided by the Vendor.

The pre-delivery tests will be scheduled and conducted with sufficient notice so that they may be witnessed by the resident inspectors, who may accept or reject the results of the tests. The results of pre-delivery tests, and any other tests, will be filed with the assembly inspection records for each vehicle. The under-floor equipment will be made available for inspection by the resident inspectors, using a hoist. A scaffold, or elevated platform will be provided by the Vendors to easily and safely inspect vehicle roofs. Delivery of each vehicle will require written authorization of a resident inspector. Authorization forms for the release of each vehicle for delivery will be provided by the Vendor. An executed copy of the authorization will accompany the delivery of each vehicle.

7.3 Inspection - Visual and Measured

Visual and measured inspections shall be conducted with the vehicle in a static condition. The purpose of the inspection testing is to verify overall dimensional and weight requirements, to verify that required components are included and are ready for operation, and to verify that components and subsystems that are designed to operate with the vehicle in a static condition do function as designed.

7.4 Total Vehicle Operation

Total vehicle operations shall be evaluated during road tests. The purpose of the road tests is to observe and verify the operation of the vehicle as a system and to verify the functional operation of the subsystem that can be operated only while the vehicle is in motion.

Each vehicle shall be driven for a minimum of 15 miles during the road tests. Observed defects shall be recorded on the test forms. The vehicle shall be retest when defects are corrected and adjustments are made. This process shall continue until defects or required adjustments are no longer detected. Results shall be pass/fail for these vehicle operation tests.

7.5 Post-Delivery Tests

The Division of Public Transit may conduct acceptance tests on each delivered vehicle. These tests shall be completed within 15 days after vehicle delivery. The purpose of these tests is to identify defects that have become apparent between the time of vehicle release and delivery to the Division of Public Transit. The post-delivery tests shall include visual inspection and vehicle operations.

Vehicles that fail to pass the post-delivery tests are subject to non-acceptance. The Division of Public Transit shall record details of all defects and shall notify the Vendor of non-acceptance of each vehicle within 5 days after completion of the tests.

7.6 Vehicle Operation

The road tests for total vehicle operation are similar to those conducted at the Vendor's plant. Operational deficiencies of each vehicle shall be identified and recorded.

PART 5 REQUIRED BID FORMS

The following certifications must be properly **completed and furnished by the bidder as part of the bid**. Failure to submit any of these certifications **shall deem the bid non-responsive**.

BID FORM #1

Location(s) of the Technical Service Representative(s) and parts distribution center(s) in the State of West Virginia.

Location(s) of the technical service representative(s).

Name: _____

Address: _____

Telephone: _____

Location(s) of parts distribution center(s).

Name: _____

Address: _____

Telephone: _____

BID FORM #2

CERTIFICATION FOR AIR POLLUTION

Pursuant to Section 8.4 of Part 1 of the Procurement, the Vendor certifies that the vehicles proposed:

_____ **ARE** or

_____ **ARE NOT** (specify one) in compliance with the regulations in 40 CFR Part 85, 40 CFR Part 86, 40 CFR Part 600 and the air pollution criteria established by the Environmental Protection Agency of the United States Government.

Date

Authorized Signature

Title

Company Name

BID FORM #3

**DISADVANTAGED BUSINESS ENTERPRISE
VENDORS/ MANUFACTURERS CERTIFICATION**

(Check appropriate statement)

_____ The Vendor, if a transit vehicle manufacturer, hereby certifies that it has complied with the requirements of 49 CFR Section 26.49 by submitting an annual DBE goal to the Federal Transit Administration (FTA). The goal has either been approved or not disapproved by FTA.

_____ The Vendor, if a non-manufacturing supplier, hereby certifies that the manufacturer of the transit vehicle to be supplied has complied with the above-referenced requirement of 49 CFR Section 26.49.

Date

Authorized Signature

Title

Company Name

BID FORM #4
BUY AMERICA CERTIFICATION
ROLLING STOCK

Certificate of Compliance

The bidder or offeror hereby certifies that it will comply with the requirements of section 165(b)(3), of the Surface Transportation Assistance Act of 1982, as amended, and the applicable regulations of 49 CFR 661.11:

Date

Authorized Signature

Company Name

Name

Title

Certificate for Non-Compliance

The bidder or offeror hereby certifies that it cannot comply with the requirements of section 165(b)(3) of the Surface Transportation Assistance Act of 1982, as amended, but may qualify for an exception to the requirement consistent with section 165(b)(2) or (b)(4) of the Surface Transportation Assistance Act, as amended, and the applicable regulations in 49 CFR 661.7.

Date

Authorized Signature

Company Name

Name

Title

BID FORM #5
FEDERAL MOTOR VEHICLE
SAFETY STANDARDS CERTIFICATION

The vendor hereby certifies that it shall submit, as required by Title 49 of the CFR, Part 663 - Subpart D, its self-certification information stating that the vehicle(s) will comply with the relevant Federal Motor Vehicle Safety Standards issued by the National Highway Traffic Safety Administration in Title 49 of the Code of Federal Regulations, Part 571.

Date

Authorized Signature

Title

Company Name

BID FORM #6

_____ hereby certifies that it

_____ **IS** or

_____ **IS NOT** (specify one) included on the U.S. Comptroller General's Consolidated List of Persons or Firms Currently Debarred for Violations of Various Public Contracts Incorporating Labor Standards Provisions.

Date

Authorized Signature

Title

Company Name

**BID FORM #6-A
CERTIFICATION OF PRIMARY PARTICIPANT REGARDING**

DEBARMENT, SUSPENSION, AND OTHER RESPONSIBILITY MATTERS

The Primary Participant (applicant for an FTA grant or cooperative agreement, or potential contractor for a major third party contract),

_____ (COMPANY NAME) certifies to the best of its knowledge and belief, that it and its principals:

1. Are not presently debarred, suspended, proposed for debarment, declared ineligible, or voluntarily excluded from covered transactions by any Federal department or agency;
2. Have not within a three-year period preceding this proposal been convicted of or had a civil judgment rendered against them for commission of fraud or a criminal offense in connection with obtaining, attempting to obtain, or performing a public (Federal, State or local) transaction or contract under a public transaction; violation of Federal or State antitrust statutes or commission of embezzlement, theft, forgery, bribery, falsification or destruction of records, making false statements, or receiving stolen property;
3. Are not presently indicted for or otherwise criminally or civilly charged by a governmental entity (Federal, State or local) with commission of any of the offenses enumerated in paragraph (2) of this certification; and
4. Have not within a three-year period preceding this application/proposal had one or more public transactions (Federal, State or local) terminated for cause or default.

If the primary participant (applicant for an FTA grant, or cooperative agreement, or potential third party contractor) is unable to certify to any of the statements in this certification, the participant shall attach an explanation to this certification.)

THE PRIMARY PARTICIPANT (APPLICANT FOR AN FTA GRANT OR COOPERATIVE AGREEMENT, OR POTENTIAL CONTRACTOR FOR A MAJOR THIRD PARTY CONTRACT),

_____, CERTIFIES OR AFFIRMS THE TRUTHFULNESS AND ACCURACY OF THE CONTENTS OF THE STATEMENTS SUBMITTED ON OR WITH THIS CERTIFICATION AND UNDERSTANDS THAT THE PROVISIONS OF 31 U.S.C. SECTIONS 3801 ET SEQ. ARE APPLICABLE THERETO.

Signature and Title of Authorized Official

BID FORM #7

VENDOR'S CERTIFICATION OF UNDERSTANDING AND ACCEPTANCE

The Vendor hereby certifies that all Technical Specifications and Contract Terms and Conditions have been carefully reviewed, are fully understood and shall be adhered to in performance and completion of any contract resulting from this bid.

Date

Authorized Signature

Title

Company Name

SPECIFICATION COMPLIANCE

NOTE: Please check if what is offered is in exact compliance with specifications. Any discrepancies must be listed as an attachment to the bid proposal. Exact dimensions and/or descriptions must be provided as a part of the Vendor's bid proposal when submitted.

_____ Bid proposal submitted meets and/or exceeds all specification requirements.

_____ Bid proposal submitted contains deviations from specification requirements. Detailed descriptions of these deviations have been provided with this bid proposal.

**BID FORM #8
CERTIFICATION OF COMPLIANCE WITH FTA'S
BUS TESTING REQUIREMENTS**

The undersigned (Vendor/Manufacturer) certifies that the vehicle offered in this procurement complies with 49 U.S.C. § 5318(e) and FTA's implementing regulation at 49 CFR Part 665.

The undersigned understands that misrepresenting the testing status of a vehicle acquired with Federal financial assistance may subject the undersigned to civil penalties as outlined in the Department of Transportation's regulation on Program Fraud Civil Remedies, 49 CFR Part 31. In addition, the undersigned understands that FTA may suspend or debar a manufacturer under the procedures in 49 CFR Part 29.

Date

Authorized Signature

Title

Company Name

**BID FORM #9
CERTIFICATION OF RESTRICTIONS ON LOBBYING**

The undersigned (Vendor, Contractor) certifies, to the best of his or her knowledge and belief, that:

1. No Federal appropriated funds have been paid or will be paid by or on behalf of the undersigned, to any person for influence or attempt to influence an officer or employee of any Federal agency, a Member of Congress, an officer or employee of Congress, or an employee of a Member of Congress regarding the award of a Federal grant, loan (including a line of credit), cooperative agreement, loan guarantee, or loan insurance, or the extension, continuation, renewal, amendment, or modification of any Federal grant, loan (including a line of credit), cooperative agreement, loan guarantee, or loan insurance.
2. If any funds other than Federal appropriated funds have been or will be paid to any person to influence or attempt to influence an officer or employee of any Federal agency, a Member of Congress, an officer or employee of Congress, or any employee of a Member of Congress in connection with any application for a Federal grant, loan (including a line of credit), cooperative agreement, loan guarantee, or loan insurance, the undersigned assures that it will complete and submit Standard Form-LLL, "Disclosure of Lobbying Activities," Rev. 7-97; and
3. The undersigned understands that the language of this certification shall be included in the award documents for all subawards at all tiers (including subcontracts, subgrants, subagreements, and contracts under grants, loans (including a line of credit), cooperative agreements, loan guarantees, and loan insurance.

Undersigned understands that this certification is a material representation of fact upon which reliance is placed by the Federal government and that submission of this certification is a prerequisite for providing a Federal grant, loan (including a line of credit), cooperative agreement, loan guarantee, or loan insurance for a transaction covered by 31 U.S.C. 1352. The undersigned also understands that any person who fails to file a required certification shall be subject to a civil penalty of not less than \$10,000 and not more than \$100,000 for each such failure.

The (Vendor, Contractor) _____, certifies or affirms the truthfulness and accuracy of each statement of its certification and disclosure, if any. In addition, the (Vendor, Contractor) understands and agrees that the provisions of 31 U.S.C. §§ 3801, et seq., apply to this certification and disclosure.

_____ Date

_____ Authorized Signature

_____ Title

PART SIX SEATING DIAGRAMS

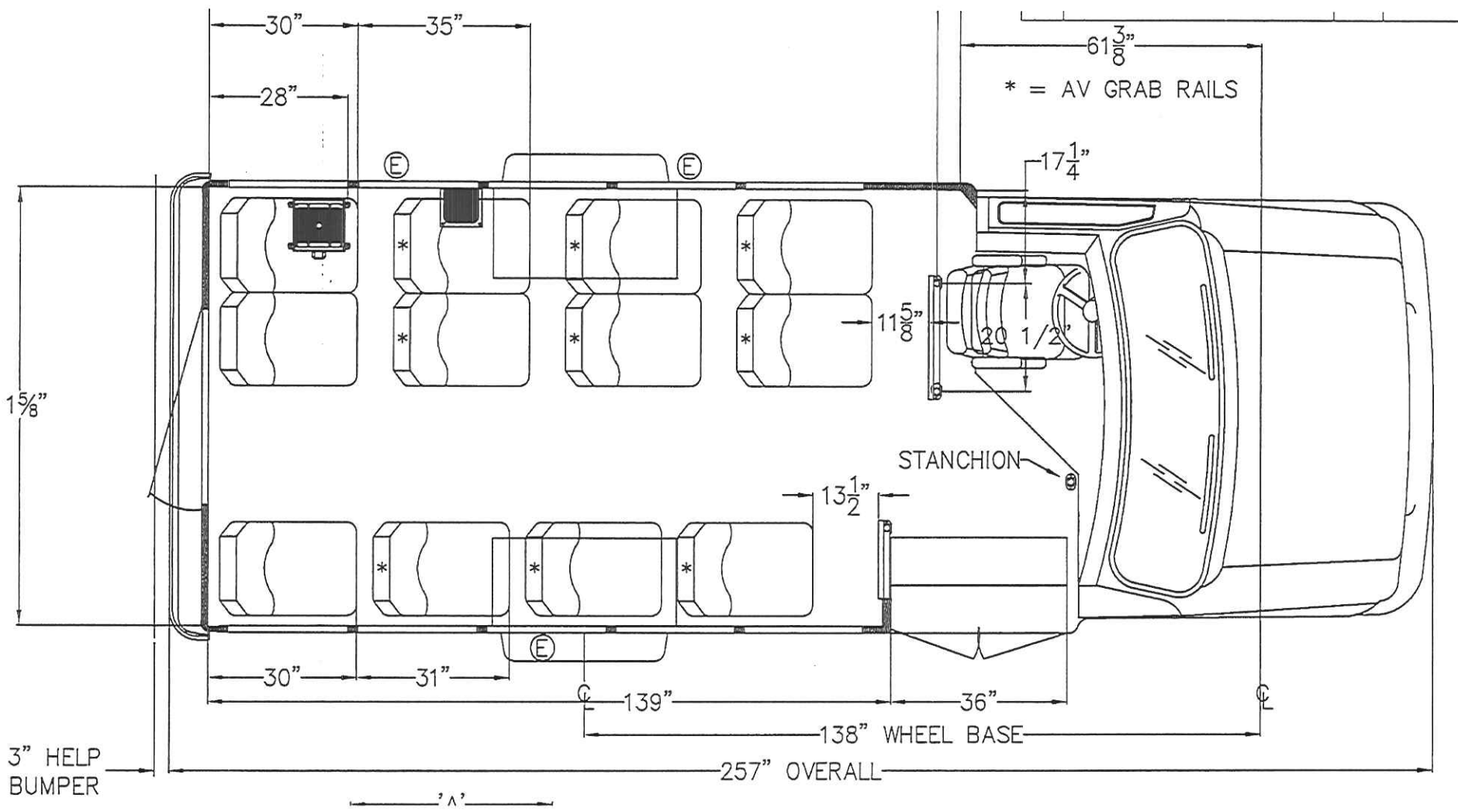

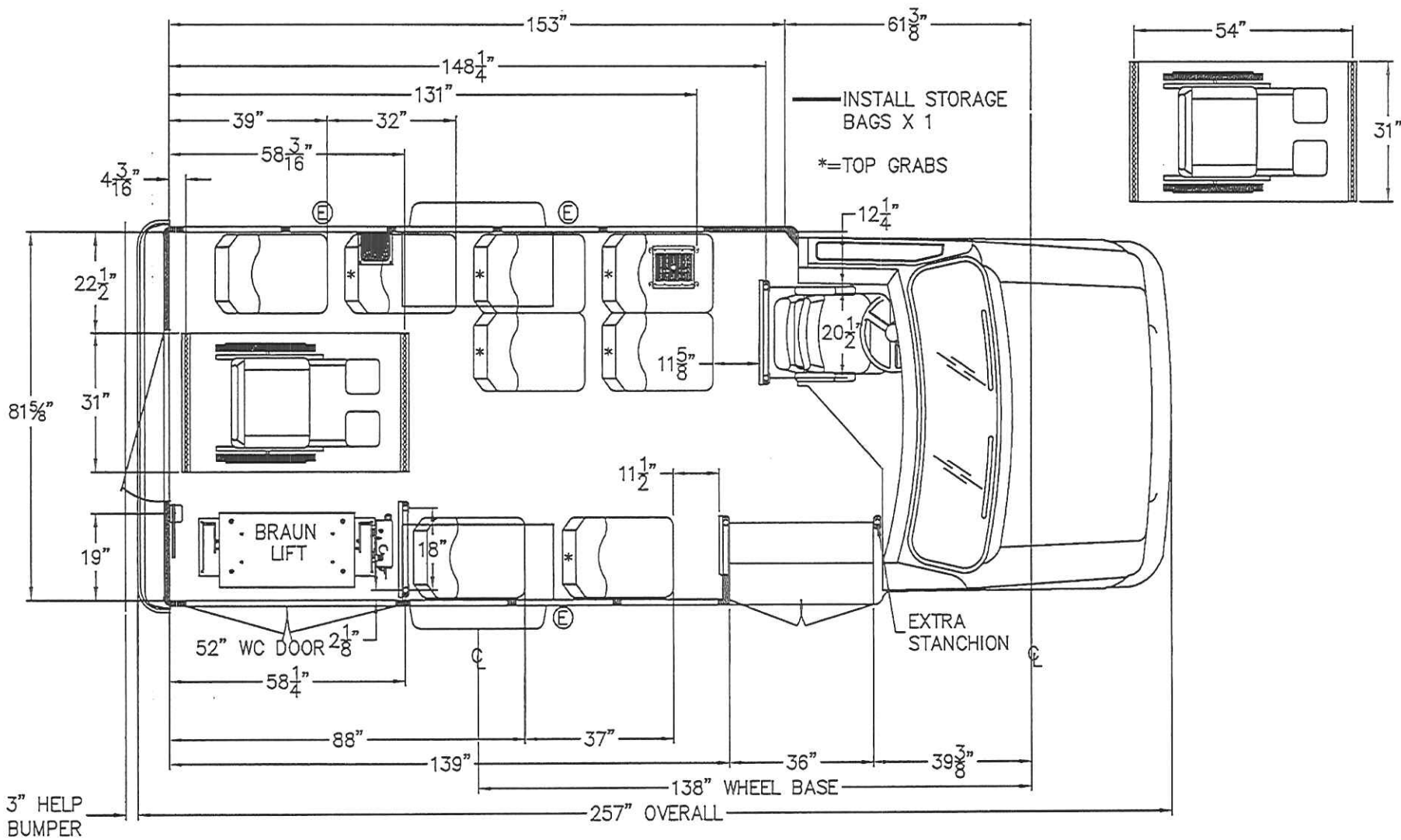

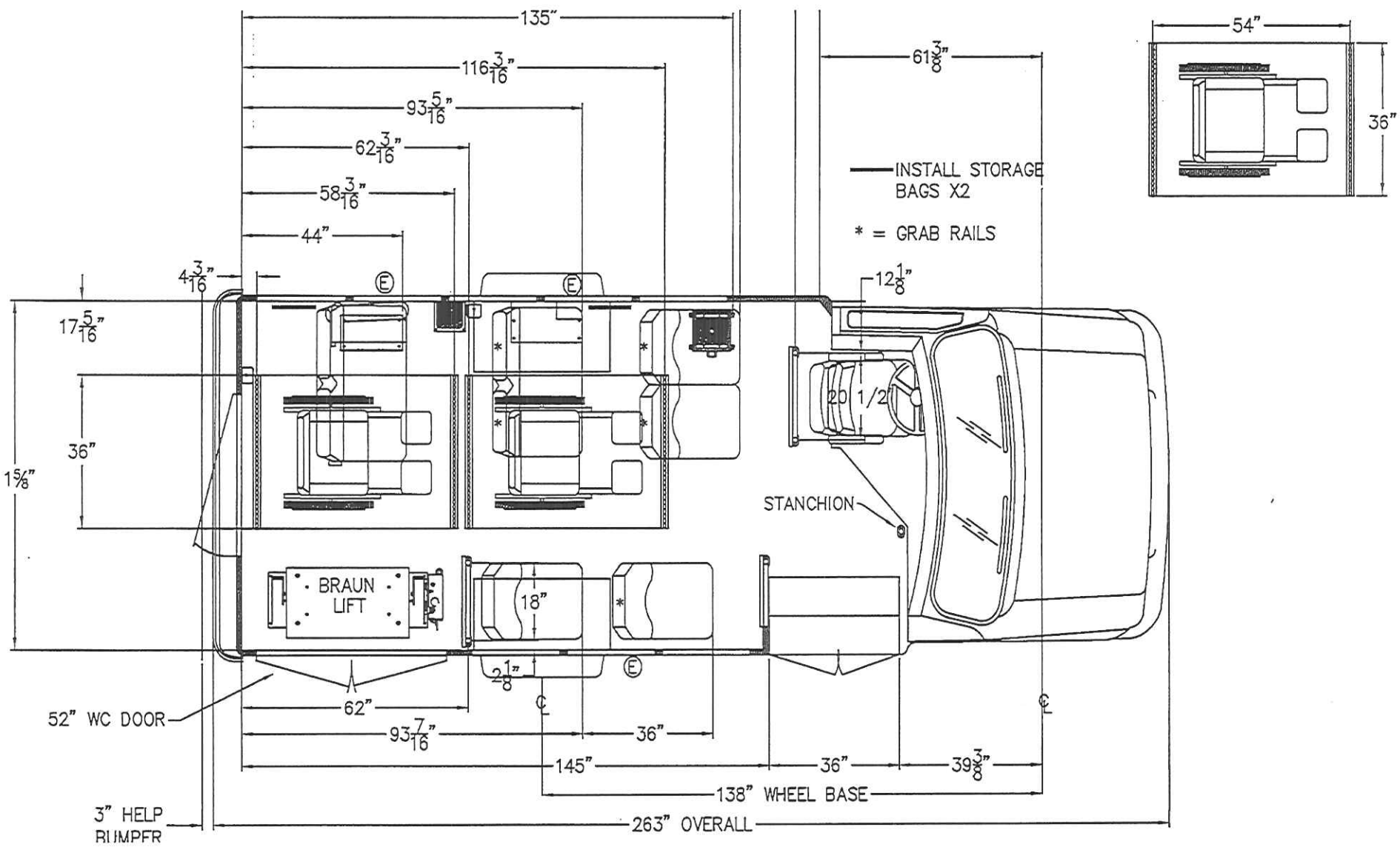

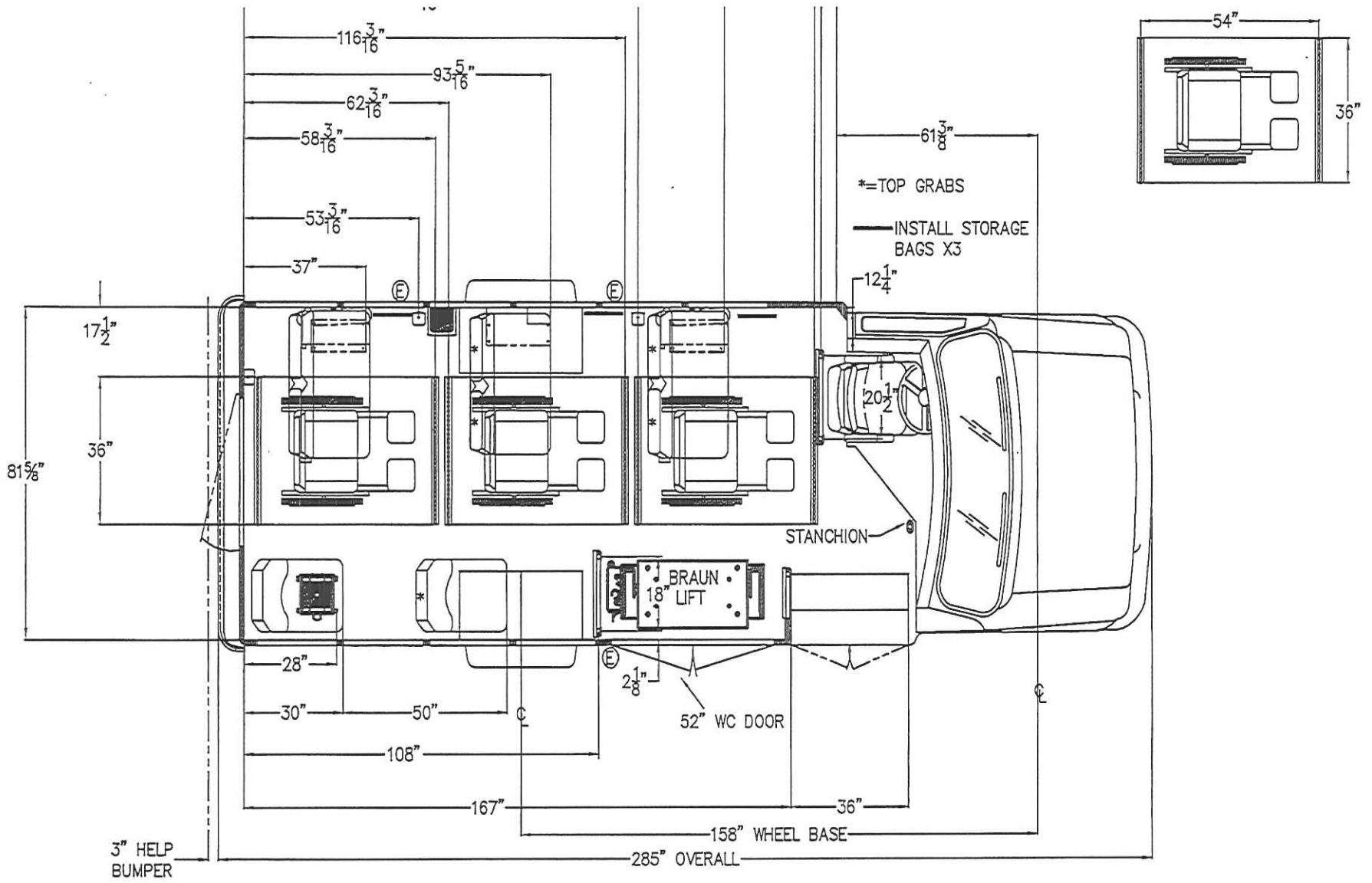

Examples of Logoing

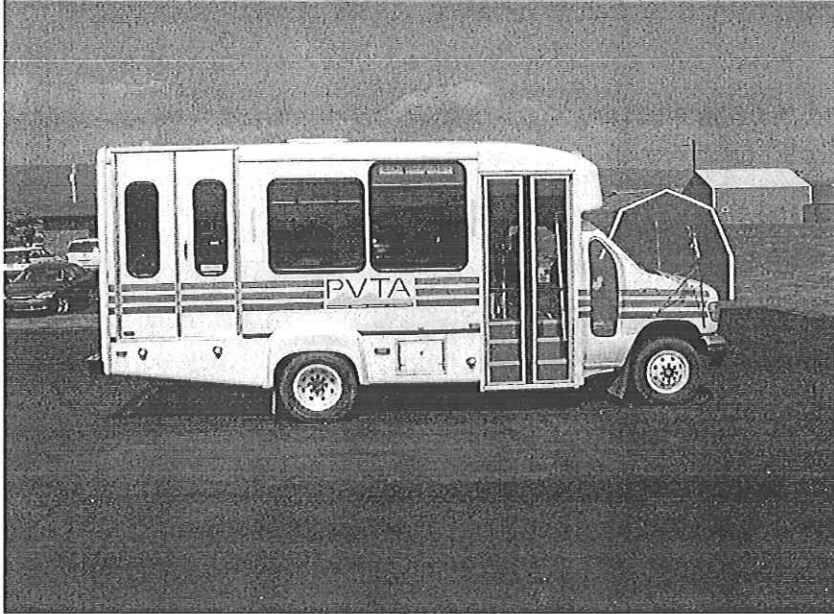



**WEST
VIRGINIA
TRANSIT
ASSISTANCE
PROGRAM**

Price for each complete van with 2 wheelchair spaces	\$ _____ each	20	\$ _____
Price for each complete van with 1 wheelchair space	\$ _____ each	20	\$ _____

OPTION PAGE

OPTION A:	NON ACCESSIBLE (credit)	\$ _____ each	20	\$ _____
OPTION B:	FIXED ROUTE PACKAGE	\$ _____ each	20	\$ _____
OPTION C:	PARATRANSIT PACKAGE	\$ _____ each	20	\$ _____
OPTION D:	CLOTH SEATS	\$ _____ each	20	\$ _____
OPTION E:	FLIP UP ARMREST FOR PASS. SEATS	\$ _____ each	20	\$ _____
OPTION F:	EXTENDED BODY W/ FRONT LIFT OPTION	\$ _____ each	20	\$ _____
OPTION G:	CHILD RESTRAINT SEAT	\$ _____ each	20	\$ _____
OPTION H:	TRAFFIC ALERT	\$ _____ each	20	\$ _____
OPTION I:	SECURITY CAMERA	\$ _____ each	20	\$ _____
OPTION J:	SECURITY CAMERA PLAYBACK SYSTEM	\$ _____ each	20	\$ _____
OPTION K:	FULL BUS BODY PAINT	\$ _____ each	20	\$ _____
OPTION L:	3/4 BODY PAINT w/ EXPANDED GRAPHICS	\$ _____ each	20	\$ _____
OPTION M:	VEHICLE SKIRT PAINTING	\$ _____ each	20	\$ _____
OPTION N:	FARE BOXES FOR VEHICLES			
	Diamond MFG: Model #XV	\$ _____ each	20	\$ _____
	Diamond MFG: Model #E-5	\$ _____ each	20	\$ _____
	Main Fare Box: Model# M-4	\$ _____ each	20	\$ _____
OPTION O:	TALKING BUS	\$ _____ each	20	\$ _____
OPTION P:	VISTA LIFT	\$ _____ each	20	\$ _____
OPTION Q:	ONLINE INSPECTION SERVICES	\$ _____ each	20	\$ _____
OPTION R:	SHOULDER BELTS	\$ _____ each	20	\$ _____

TOTAL FOR BID EVALUATION: \$ _____

STATE OF WEST VIRGINIA
Purchasing Division

PURCHASING AFFIDAVIT

West Virginia Code §5A-3-10a states: No contract or renewal of any contract may be awarded by the state or any of its political subdivisions to any vendor or prospective vendor when the vendor or prospective vendor or a related party to the vendor or prospective vendor is a debtor and the debt owed is an amount greater than one thousand dollars in the aggregate.

DEFINITIONS:

"Debt" means any assessment, premium, penalty, fine, tax or other amount of money owed to the state or any of its political subdivisions because of a judgment, fine, permit violation, license assessment, defaulted workers' compensation premium, penalty or other assessment presently delinquent or due and required to be paid to the state or any of its political subdivisions, including any interest or additional penalties accrued thereon.

"Debtor" means any individual, corporation, partnership, association, limited liability company or any other form or business association owing a debt to the state or any of its political subdivisions. "Political subdivision" means any county commission; municipality; county board of education; any instrumentality established by a county or municipality; any separate corporation or instrumentality established by one or more counties or municipalities, as permitted by law; or any public body charged by law with the performance of a government function or whose jurisdiction is coextensive with one or more counties or municipalities. "Related party" means a party, whether an individual, corporation, partnership, association, limited liability company or any other form or business association or other entity whatsoever, related to any vendor by blood, marriage, ownership or contract through which the party has a relationship of ownership or other interest with the vendor so that the party will actually or by effect receive or control a portion of the benefit, profit or other consideration from performance of a vendor contract with the party receiving an amount that meets or exceed five percent of the total contract amount.

EXCEPTION: The prohibition of this section does not apply where a vendor has contested any tax administered pursuant to chapter eleven of this code, workers' compensation premium, permit fee or environmental fee or assessment and the matter has not become final or where the vendor has entered into a payment plan or agreement and the vendor is not in default of any of the provisions of such plan or agreement.

Under penalty of law for false swearing (*West Virginia Code* §61-5-3), it is hereby certified that the vendor affirms and acknowledges the information in this affidavit and is in compliance with the requirements as stated.

WITNESS THE FOLLOWING SIGNATURE

Vendor's Name: _____

Authorized Signature: _____ Date: _____

State of _____

County of _____, to-wit:

Taken, subscribed, and sworn to before me this ___ day of _____, 20__.

My Commission expires _____, 20__.

AFFIX SEAL HERE

NOTARY PUBLIC _____