

Carbon Steel Ball Valves

Two-Piece Bar Stock Body • Conventional Port •
Blowout-Proof Stem • 316 SS Trim • Vented Ball

2000 PSI/138 Bar Non-Shock Cold Working Pressure (1/4"-1")
1500 PSI/103 Bar Non Shock Cold Working Pressure (1 1/4"-2") ♦

CONFORMS TO MSS SP-110

MATERIAL LIST

PART	SPECIFICATION
1. Handle Nut	Carbon Steel ASTM A 283
2. Stem	Stainless Steel ASTM A 276 Type 316
3. Lock Washer	Carbon Steel
4. Belleville Washer (2)	Carbon Steel ASTM A 686
5. Stem Packing (2)	Reinforced PTFE
6. Thrust Washer	Carbon Filled PTFE
7. Body End Piece	Carbon Steel ASTM A 108 Type 1018
8. Spacer Seal	PTFE
9. Ball (Vented)	Stainless Steel ASTM A 276 Type 316 or ASTM A 351 Type CF8M
10. Seat (2)	Reinforced PTFE
11. Body	Carbon Steel ASTM A 108 Type 1018
12. Gland Washer	Stainless Steel ASTM A 240 Type 304
13. Handle	Carbon Steel ASTM A 283

1/4"-1" 2000 PSI CWP, 1 1/4"-2" 1500 PSI CWP.

NOTE: Valves are static grounded by thrust washer and packing.



T-580-CS-R-66
Threaded

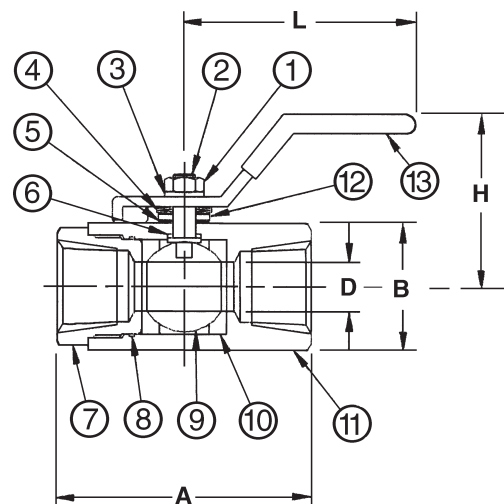

T-580-CS-R-66
NPT x NPT

DIMENSIONS—WEIGHTS—QUANTITIES

Size	Dimensions						T-580-CS-R-66		Master Ctn. Qty.
	A	B	D	H	L	Lbs.	Kg.		
In. mm.	In. mm.	In. mm.	In. mm.	In. mm.	In. mm.				
1/4 8	2.30 58	1.02 26	.38 10	2.22 56	4.13 105	.59	.27	10	
3/8 10	2.30 58	1.02 26	.38 10	2.22 56	4.13 105	.55	.25	10	
1/2 15	2.52 64	1.26 32	.50 10	2.44 62	4.17 105	.79	.36	10	
3/4 20	2.95 75	1.61 41	.69 13	2.64 66	4.17 105	1.43	.65	10	
1 25	3.35 85	1.97 50	.89 18	2.83 72	5.83 148	2.40	1.08	10	
1 1/4 32	3.66 93	2.17 55	1.00 25	2.97 75	5.83 148	3.01	1.37	5	
1 1/2 40	4.11 104	2.64 67	1.25 32	3.25 83	7.00 182	4.80	2.20	5	
2 50	4.61 117	3.03 77	1.50 38	3.54 90	7.24 185	6.62	3.00	5	

♦ For detailed Operating Pressure, refer to Pressure Temperature Chart on pages 66 and 67.