



State of West Virginia
 Department of Administration
 Purchasing Division
 2019 Washington Street East
 Post Office Box 50130
 Charleston, WV 25305-0130

Request for Quotation

RFQ NUMBER
DNRB12009

PAGE
1

ADDRESS CORRESPONDENCE TO ATTENTION OF
FRANK WHITTAKER 304-558-2316

VENDOR

RFQ COPY
 TYPE NAME/ADDRESS HERE

SHIP TO

DIVISION OF NATURAL RESOURCES
 PARKS & RECREATION SECTION
 324 4TH AVENUE
 SOUTH CHARLESTON, WV
 25303-1228 304-558-3397

DATE PRINTED	TERMS OF SALE	SHIP VIA	F.O.B.	FREIGHT TERMS
08/17/2011				
BID OPENING DATE: 08/31/2011		BID OPENING TIME 01:30PM		

LINE	QUANTITY	UOP	CAT NO	ITEM NUMBER	UNIT PRICE	AMOUNT
***** ADDENDUM NO. 2 *****						
THIS ADDENDUM IS ISSUED TO PROVIDE THE FOLLOWING:						
1) THE ATTACHED REVISION TO THE SPECIFICATIONS INCLUDING DRAWINGS: SK-1 AND SK-2.						
2) TECHNICAL QUESTIONS AND ANSWERS.						
3) MANDATORY PRE-BID SIGN IN SHEET.						
BID OPENING DATE AND TIME HAVE NOT CHANGED.						
***** END ADDENDUM NO. 2 *****						

SEE REVERSE SIDE FOR TERMS AND CONDITIONS

SIGNATURE	TELEPHONE	DATE
TITLE	FEIN	ADDRESS CHANGES TO BE NOTED ABOVE

WHEN RESPONDING TO RFQ, INSERT NAME AND ADDRESS IN SPACE ABOVE LABELED 'VENDOR'

GENERAL TERMS & CONDITIONS REQUEST FOR QUOTATION (RFQ) AND REQUEST FOR PROPOSAL (RFP)

1. Awards will be made in the best interest of the State of West Virginia.
2. The State may accept or reject in part, or in whole, any bid.
3. Prior to any award, the apparent successful vendor must be properly registered with the Purchasing Division and have paid the required \$125 fee.
4. All services performed or goods delivered under State Purchase Order/Contracts are to be continued for the term of the Purchase Order/Contracts, contingent upon funds being appropriated by the Legislature or otherwise being made available. In the event funds are not appropriated or otherwise available for these services or goods this Purchase Order/Contract becomes void and of no effect after June 30.
5. Payment may only be made after the delivery and acceptance of goods or services.
6. Interest may be paid for late payment in accordance with the *West Virginia Code*.
7. Vendor preference will be granted upon written request in accordance with the *West Virginia Code*.
8. The State of West Virginia is exempt from federal and state taxes and will not pay or reimburse such taxes.
9. The Director of Purchasing may cancel any Purchase Order/Contract upon 30 days written notice to the seller.
10. The laws of the State of West Virginia and the *Legislative Rules* of the Purchasing Division shall govern the purchasing process.
11. Any reference to automatic renewal is hereby deleted. The Contract may be renewed only upon mutual written agreement of the parties.
12. **BANKRUPTCY:** In the event the vendor/contractor files for bankruptcy protection, the State may deem this contract null and void, and terminate such contract without further order.
13. **HIPAA BUSINESS ASSOCIATE ADDENDUM:** The West Virginia State Government HIPAA Business Associate Addendum (BAA), approved by the Attorney General, is available online at www.state.wv.us/admin/purchase/vrc/hipaa.htm and is hereby made part of the agreement. Provided that the Agency meets the definition of a Cover Entity (45 CFR §160.103) and will be disclosing Protected Health Information (45 CFR §160.103) to the vendor.
14. **CONFIDENTIALITY:** The vendor agrees that he or she will not disclose to anyone, directly or indirectly, any such personally identifiable information or other confidential information gained from the agency, unless the individual who is the subject of the information consents to the disclosure in writing or the disclosure is made pursuant to the agency's policies, procedures, and rules. Vendor further agrees to comply with the Confidentiality Policies and Information Security Accountability Requirements, set forth in <http://www.state.wv.us/admin/purchase/privacy/noticeConfidentiality.pdf>.
15. **LICENSING:** Vendors must be licensed and in good standing in accordance with any and all state and local laws and requirements by any state or local agency of West Virginia, including, but not limited to, the West Virginia Secretary of State's Office, the West Virginia Tax Department, and the West Virginia Insurance Commission. The vendor must provide all necessary releases to obtain information to enable the director or spending unit to verify that the vendor is licensed and in good standing with the above entities.
16. **ANTITRUST:** In submitting a bid to any agency for the State of West Virginia, the bidder offers and agrees that if the bid is accepted the bidder will convey, sell, assign or transfer to the State of West Virginia all rights, title and interest in and to all causes of action it may now or hereafter acquire under the antitrust laws of the United States and the State of West Virginia for price fixing and/or unreasonable restraints of trade relating to the particular commodities or services purchased or acquired by the State of West Virginia. Such assignment shall be made and become effective at the time the purchasing agency tenders the initial payment to the bidder.

I certify that this bid is made without prior understanding, agreement, or connection with any corporation, firm, limited liability company, partnership, or person or entity submitting a bid for the same material, supplies, equipment or services and is in all respects fair and without collusion or Fraud. I further certify that I am authorized to sign the certification on behalf of the bidder or this bid.

INSTRUCTIONS TO BIDDERS

1. Use the quotation forms provided by the Purchasing Division. Complete all sections of the quotation form.
2. Items offered must be in compliance with the specifications. Any deviation from the specifications must be clearly indicated by the bidder. Alternates offered by the bidder as **EQUAL** to the specifications must be clearly defined. A bidder offering an alternate should attach complete specifications and literature to the bid. The Purchasing Division may waive minor deviations to specifications.
3. Unit prices shall prevail in case of discrepancy. All quotations are considered F.O.B. destination unless alternate shipping terms are clearly identified in the quotation.
4. All quotations must be delivered by the bidder to the office listed below prior to the date and time of the bid opening. Failure of the bidder to deliver the quotations on time will result in bid disqualifications: Department of Administration, Purchasing Division, 2019 Washington Street East, P.O. Box 50130, Charleston, WV 25305-0130
5. Communication during the solicitation, bid, evaluation or award periods, except through the Purchasing Division, is strictly prohibited (W.Va. C.S.R. §148-1-6.6).

**Canaan Valley Resort State Park
Ski Area Improvements Project
Parking Lot Drainage Improvements
Requisition DNRB12009**

Bidder Questions and Answers

1. Is asphalt to be put back over trenches?

Answer: In the parking lot areas, the top six inches of the trench shall be gravel, unless otherwise noted. Where trenches cross asphalt roads, the road shall be repaired with asphalt in accordance with the trench repair detail on the drawings. Existing asphalt pavement to be removed for trench excavation shall be saw-cut.

2. Can concrete be substituted for asphalt for the pavement repair?

Answer: No, asphalt shall be used for the pavement repair.

3. Is there a waste area on site?

Answer: Yes, a waste area on site will be provided.

4. Is gravel required for the pipe backfill?

Pipe backfill shall be as specified in specification section 02210, Trench Excavation and Backfill.

- end of questions and answers -



**Canaan Valley Resort State Park
Ski Area Improvements Project
Parking Lot Drainage Improvements
Requisition DNRB12009
Addendum**

1. Specification Section 02731, Manholes, Drop Inlets and Cleanouts, shall be deleted from the Index to Detail Specifications.
2. Drawing C4, Type G Inlet Detail shall be deleted.
3. Sketch SK-1, shall be incorporated into the Contact Documents and shall be used for all inlets shown on the Drawings. Inlet grate G-2 shall be used for inlets 1-13, 1-14, and 1-15; 2-1; and 5-1 and 5-2. Inlet Grate G-1 shall be used for all other inlets.
4. Trench Dams shall be installed in the trenches of Storm Line 1 from Inlet 1-1 to Inlet 1-6, in accordance with Sketch SK-2.
5. Acceptable manufacturers of HDPE pipe include but are not necessarily limited to the following:

Advanced Drainage Systems, Inc.
Haviland Drainage Products, Inc.
Hancor, Inc.

5. Bidders should indicate receipt of this addendum in the space provided on the Request for Quotation.

Issued by Chapman Technical Group

Joseph E. Bird, ASLA

200 Sixth Avenue
St. Albans, WV 25177

304.727.5501
FAX 304.727.5580

Buckhannon, WV
Martinsburg, WV

www.chapttech.com

INLET BOX SIZING	
PIPE SIZE	A
12"	2'-8"
18"	2'-8"
21"	2'-8"
24"	2'-8"
27"	3'-0"
30"	3'-6"
33"	3'-9"
36"	4'-0"
42"	4'-6"
48"	5'-0"

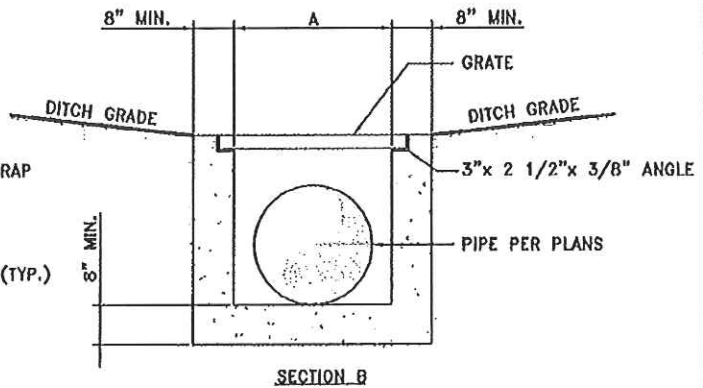
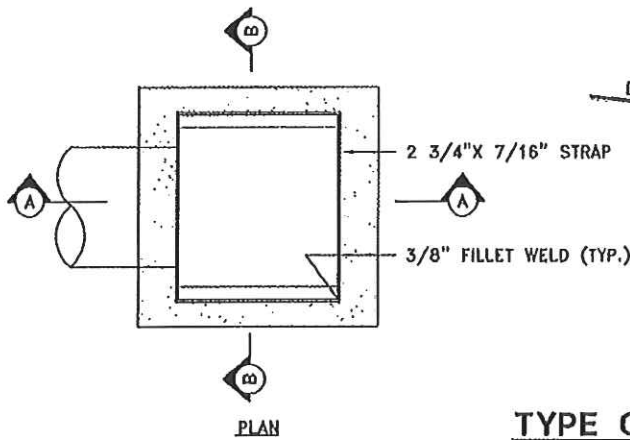
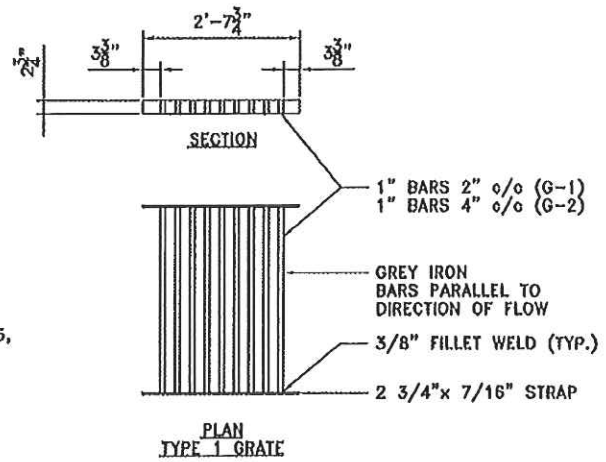
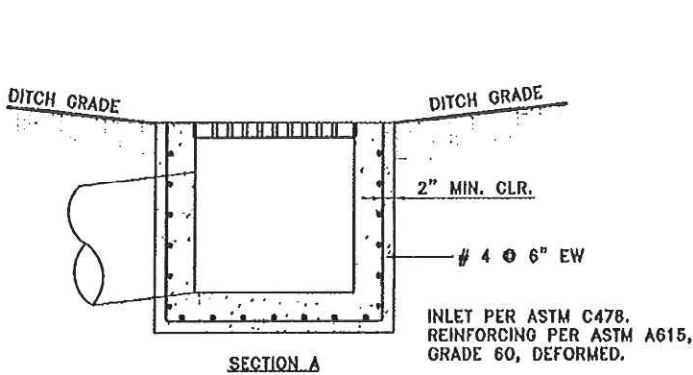

TYPE G INLET DETAIL
SCALE: NONE (0272015)

P:\Projects\111022\02\Contract 1 - Parking Lot Storm Drainage Improvements\11022-A0-0-INTL.dwg - 8/5/2011 3:52:12 AM - 11022



AIRPORT PLANNING / DEVELOPMENT
ARCHITECTURE / INTERIOR DESIGN
CIVIL ENGINEERING / SITE DEVELOPMENT
ENVIRONMENTAL ENGINEERING
LANDSCAPE ARCHITECTURE
SURVEYING

St. Albans, WV (304) 727-5501
Buckhannon, WV (304) 472-8914
Martinsburg, WV (304) 260-1222
www.chaptech.com

West Virginia Division of Natural Resources
Parks and Recreation
Canaan Valley Resort State Park
Ski Improvements Project
Parking Lot Drainage Improvements - Contract No. 1
Modified Type G Inlet

JOB NUMBER:	11022
SCALE:	NONE
DATE:	8/8/11
DRAWN BY:	FLB
DESIGNED BY:	JEB
CHECKED BY:	JEB
SHEET NO.	SK-1
REVISOR	△

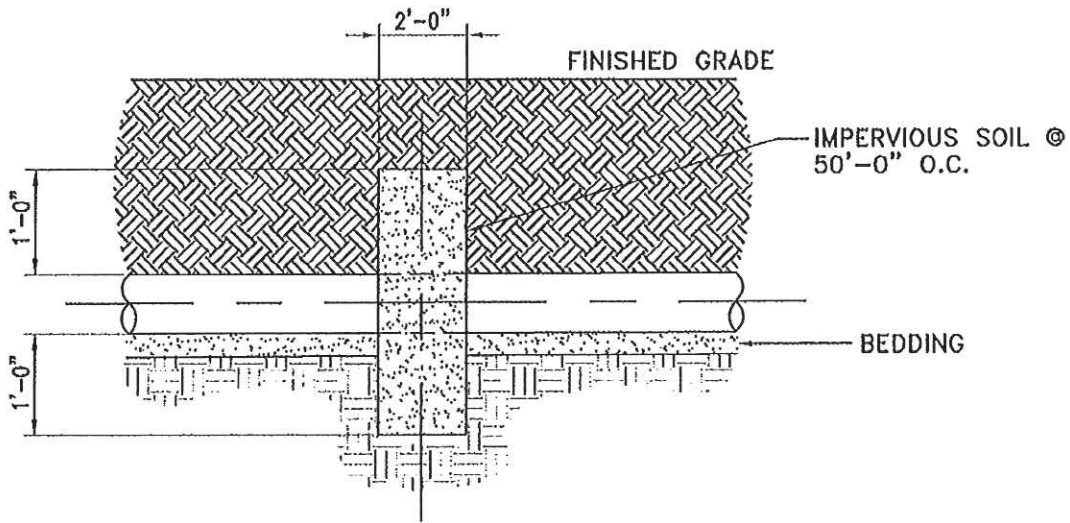

TRENCH DAM DETAIL

SCALE: NONE

H:\Projects\1\11022\Coord\Contract 1 - Parking Lot Storm Drainage\ADDENDUM\11022-st2.dwg, 8/12/2011 9:51:12 AM, 11b59

 <p>Chapman Technical Group</p>	AIRPORT PLANNING / DEVELOPMENT	St Albans, WV (304) 727-5501	<p>West Virginia Division of Natural Resources Parks and Recreation Canaan Valley Resort State Park Ski Improvements Project Parking Lot Drainage Improvements - Contract No. 1 Trench Dam Detail</p>	JOB NUMBER	11022	<p>SHEET NO. SK-2</p> <p>REVISION △</p>
	ARCHITECTURE / INTERIOR DESIGN	Buckhannon, WV (304) 472-8014		SCALE	NONE	
	CIVIL ENGINEERING / SITE DEVELOPMENT	Martinsburg, WV (304) 200-1222		DATE	8/12/11	
	ENVIRONMENTAL ENGINEERING	www.chapttech.com		DRAWN BY	FLB	
	LANDSCAPE ARCHITECTURE			DESIGNED BY	JEB	
SURVEYING			CHECKED BY	JEB		

PRE-BID CONFERENCE
SIGN IN SHEET

Request for Quotation Number DRRB 12009 Date August 11, 2011 Park Canaan Valley

PLEASE PRINT LEGIBLY. THIS INFORMATION IS ESSENTIAL TO CONTACT THE ATTENDEES IN A TIMELY MANNER. FAILURE TO DO SO MAY RESULT IN DELAYS IN YOUR COMPANY GETTING IMPORTANT BID INFORMATION.

Firm Name: JF Allen Co
Firm Address: PO Box 2049
Buckhannon WV
26201

Representative Attending: Scott Buschert
Phone Number: 304-472-8890
Fax Number: 304-472-8897
Email Address: EPhares@JFALLENCO.COM

Firm Name: Wiscamp, Const
Firm Address: 1616 Sixth Avenue
Charleston West V. 25312

Representative Attending: T.C Linkinager
Phone Number: 304-344-1288
Fax Number: 304-344-1281
Email Address: lww@w.comanconst.com

Firm Name: Beekeeping Inc
Firm Address: 1075 Old Thompson Pike Rd
Sta. Ton WV 26601

Representative Attending: Dan Vincent
Phone Number: 304 765-5317
Fax Number: 304 765-5389
Email Address: davin@beekeepingwv.com

Firm Name: Towers & Nasser
Firm Address: 214 Main St
Buckhannon WV 26254

Representative Attending: Scott Buschert
Phone Number: 304 263 4500
Fax Number: 290 6368
Email Address:

Firm Name: Capitol Valley
Firm Address: 60 Renee Drive
Elkins W.V. 25071

Representative Attending: Chris Allen
Phone Number: 304 437-4505
Fax Number: 304 965-2223
Email Address: mickel@capitol-valley.com

Firm Name: ROVER Const.
Firm Address: St. AUGUSTS WV

Representative Attending: STE PROSPEUSICA
Phone Number: 304-759-2100
Fax Number:
Email Address:

PRE-BID CONFERENCE
SIGN IN SHEET

Request for Quotation Number DNRB12009 Date August 11, 2011 Park Canaan Valley

PLEASE PRINT LEGIBLY. THIS INFORMATION IS ESSENTIAL TO CONTACT THE ATTENDEES IN A TIMELY MANNER. FAILURE TO DO SO MAY RESULT IN DELAYS IN YOUR COMPANY GETTING IMPORTANT BID INFORMATION.

<p>Firm Name: <u>Pro Contracting Inc</u> Firm Address: <u>PO Box 2442</u> <u>Clarksburg, WV 26363</u></p> <p>Representative Attending: <u>Mat Evans</u> Phone Number: <u>304 622-2400</u> Fax Number: <u>304 - 622 - 2410</u> Email Address: <u>MEvans@procty.com</u></p>	<p>Firm Name: <u>W. Hazley Mauer Contractors</u> Firm Address: <u>1193 Hedgesville Road</u> <u>Woodsburg, W.Va. 25403</u></p> <p>Representative Attending: <u>TERRY AIKENS</u> Phone Number: <u>304-267-8959</u> Fax Number: <u>304-267-3847</u> Email Address: <u>AIkens@whmcontractors.com</u></p>
<p>Firm Name: <u>Nelson Howard</u> Firm Address: <u>PO Box 898</u> <u>Thomass</u></p> <p>Representative Attending: <u>Sumner Sillman</u> Phone Number: <u>304 463 4313</u> Fax Number: <u>304 463 4311</u> Email Address:</p>	<p>Firm Name: <u>ITZYS Rude Court Co.</u> Firm Address: <u>PO Box 428</u> <u>Institute WV 25112</u></p> <p>Representative Attending: <u>Kenneth S Hayes</u> Phone Number: <u>304-776-0448</u> Fax Number: <u>304-776 0451</u> Email Address: <u>ITZYSRude@rcr.com</u></p>
<p>Firm Name: <u>L&L Contracting</u> Firm Address: <u>7451 WV Hwy 5E</u> <u>Bucarsville WV 26335</u></p> <p>Representative Attending: <u>Daniel Lohis</u> Phone Number: <u>304-290-3303</u> Fax Number: <u>304-290-3303 - 304-295-5592</u> Email Address: <u>lohis.daniel@yahoo.com</u></p>	<p>Firm Name:</p> <p>Firm Address:</p> <p>Representative Attending:</p> <p>Phone Number:</p> <p>Fax Number:</p> <p>Email Address:</p>