



State of West Virginia
 Department of Administration
 Purchasing Division
 2019 Washington Street East
 Post Office Box 50130
 Charleston, WV 25305-0130

Request for Quotation

RFQ NUMBER
8512C2040

PAGE
1

ADDRESS CORRESPONDENCE TO ATTENTION OF:
ALAN CUMMINGS 304-558-2402

VENDOR

RFQ COPY
 TYPE NAME/ADDRESS HERE

SHIP TO

DIVISION OF HIGHWAYS
 TRAFFIC ENGINEERING DIVISION
 VARIOUS LOCALES AS INDICATED
 BY ORDER

DATE PRINTED	TERMS OF SALE	SHIP VIA	F.O.B	FREIGHT TERMS
04/16/2012				

BID OPENING DATE: **05/02/2012** **BID OPENING TIME 01:30PM**

LINE	QUANTITY	UOP	CAT. NO.	ITEM NUMBER	UNIT PRICE	AMOUNT
0001	1	LS		550-42		
	SAFETY SAND BARRELS					
	OPEN-END CONTRACT					
	THE WEST VIRGINIA STATE PURCHASING DIVISION FOR THE AGENCY, THE WEST VIRGINIA DIVISION OF HIGHWAYS, IS SOLICITING BIDS TO PROVIDE THE AGENCY WITH AN OPEN-END CONTRACT TO FURNISH THE REQUIRED MATERIALS NECESSARY FOR THE MAINTENANCE OF ENERGY ABSORPTION SYSTEM FITCH SAND BARRELS, PLASTIC SAFETY SYSTEMS CRASHGARD SAND BARRELS, OR TRAFFIX DEVICES SAND BARRELS PER THE ATTACHED SPECIFICATIONS.					
	EXHIBIT 3					
	LIFE OF CONTRACT: THIS CONTRACT BECOMES EFFECTIVE ON AWARD AND EXTENDS FOR A PERIOD OF ONE (1) YEAR OR UNTIL SUCH "REASONABLE TIME" THEREAFTER AS IS NECESSARY TO OBTAIN A NEW CONTRACT OR RENEW THE ORIGINAL CONTRACT. THE "REASONABLE TIME" PERIOD SHALL NOT EXCEED TWELVE (12) MONTHS. DURING THIS "REASONABLE TIME" THE VENDOR MAY TERMINATE THIS CONTRACT FOR ANY REASON UPON GIVING THE DIRECTOR OF PURCHASING 30 DAYS WRITTEN NOTICE.					
	UNLESS SPECIFIC PROVISIONS ARE STIPULATED ELSEWHERE IN THIS CONTRACT DOCUMENT BY THE STATE OF WEST VIRGINIA, ITS AGENCIES, OR POLITICAL SUBDIVISIONS, THE TERMS, CONDITIONS, AND PRICING SET FORTH HEREIN ARE FIRM FOR THE LIFE OF THE CONTRACT.					

SEE REVERSE SIDE FOR TERMS AND CONDITIONS

SIGNATURE	TELEPHONE	DATE
TITLE	FEIN	ADDRESS CHANGES TO BE NOTED ABOVE

WHEN RESPONDING TO RFQ, INSERT NAME AND ADDRESS IN SPACE ABOVE LABELED 'VENDOR'

GENERAL TERMS & CONDITIONS REQUEST FOR QUOTATION (RFQ) AND REQUEST FOR PROPOSAL (RFP)

1. Awards will be made in the best interest of the State of West Virginia.
2. The State may accept or reject in part, or in whole, any bid.
3. Prior to any award, the apparent successful vendor must be properly registered with the Purchasing Division and have paid the required \$125 fee.
4. All services performed or goods delivered under State Purchase Order/Contracts are to be continued for the term of the Purchase Order/Contracts, contingent upon funds being appropriated by the Legislature or otherwise being made available. In the event funds are not appropriated or otherwise available for these services or goods this Purchase Order/Contract becomes void and of no effect after June 30.
5. Payment may only be made after the delivery and acceptance of goods or services.
6. Interest may be paid for late payment in accordance with the *West Virginia Code*.
7. Vendor preference will be granted upon written request in accordance with the *West Virginia Code*.
8. The State of West Virginia is exempt from federal and state taxes and will not pay or reimburse such taxes.
9. The Director of Purchasing may cancel any Purchase Order/Contract upon 30 days written notice to the seller.
10. The laws of the State of West Virginia and the *Legislative Rules* of the Purchasing Division shall govern the purchasing process.
11. Any reference to automatic renewal is hereby deleted. The Contract may be renewed only upon mutual written agreement of the parties.
12. **BANKRUPTCY:** In the event the vendor/contractor files for bankruptcy protection, the State may deem this contract null and void, and terminate such contract without further order.
13. **HIPAA BUSINESS ASSOCIATE ADDENDUM:** The West Virginia State Government HIPAA Business Associate Addendum (BAA), approved by the Attorney General, is available online at www.state.wv.us/admin/purchase/vrc/hipaa.html and is hereby made part of the agreement provided that the Agency meets the definition of a Cover Entity (45 CFR §160.103) and will be disclosing Protected Health Information (45 CFR §160.103) to the vendor.
14. **CONFIDENTIALITY:** The vendor agrees that he or she will not disclose to anyone, directly or indirectly, any such personally identifiable information or other confidential information gained from the agency, unless the individual who is the subject of the information consents to the disclosure in writing or the disclosure is made pursuant to the agency's policies, procedures, and rules. Vendor further agrees to comply with the Confidentiality Policies and Information Security Accountability Requirements, set forth in <http://www.state.wv.us/admin/purchase/privacy/noticeConfidentiality.pdf>.
15. **LICENSING:** Vendors must be licensed and in good standing in accordance with any and all state and local laws and requirements by any state or local agency of West Virginia, including, but not limited to, the West Virginia Secretary of State's Office, the West Virginia Tax Department, and the West Virginia Insurance Commission. The vendor must provide all necessary releases to obtain information to enable the director or spending unit to verify that the vendor is licensed and in good standing with the above entities.
16. **ANTITRUST:** In submitting a bid to any agency for the State of West Virginia, the bidder offers and agrees that if the bid is accepted the bidder will convey, sell, assign or transfer to the State of West Virginia all rights, title and interest in and to all causes of action it may now or hereafter acquire under the antitrust laws of the United States and the State of West Virginia for price fixing and/or unreasonable restraints of trade relating to the particular commodities or services purchased or acquired by the State of West Virginia. Such assignment shall be made and become effective at the time the purchasing agency tenders the initial payment to the bidder.

I certify that this bid is made without prior understanding, agreement, or connection with any corporation, firm, limited liability company, partnership, or person or entity submitting a bid for the same material, supplies, equipment or services and is in all respects fair and without collusion or fraud. I further certify that I am authorized to sign the certification on behalf of the bidder or this bid.

INSTRUCTIONS TO BIDDERS

1. Use the quotation forms provided by the Purchasing Division. Complete all sections of the quotation form.
2. Items offered must be in compliance with the specifications. Any deviation from the specifications must be clearly indicated by the bidder. Alternates offered by the bidder as **EQUAL** to the specifications must be clearly defined. A bidder offering an alternate should attach complete specifications and literature to the bid. The Purchasing Division may waive minor deviations to specifications.
3. Unit prices shall prevail in case of discrepancy. All quotations are considered F.O.B. destination unless alternate shipping terms are clearly identified in the quotation.
4. All quotations must be delivered by the bidder to the office listed below prior to the date and time of the bid opening. Failure of the bidder to deliver the quotations on time will result in bid disqualifications: Department of Administration, Purchasing Division, 2019 Washington Street East, P.O. Box 50130, Charleston, WV 25305-0130
5. Communication during the solicitation, bid, evaluation or award periods, except through the Purchasing Division, is strictly prohibited (W.Va. C.S.R. §148-1-6.6).



State of West Virginia
 Department of Administration
 Purchasing Division
 2019 Washington Street East
 Post Office Box 50130
 Charleston, WV 25305-0130

Request for Quotation

RFQ NUMBER
 8512C2040

PAGE
 2

ADDRESS CORRESPONDENCE TO ATTENTION OF:
 ALAN CUMMINGS
 304-558-2402

VENDOR

RFQ COPY
 TYPE NAME/ADDRESS HERE

SHIP TO

DIVISION OF HIGHWAYS
 TRAFFIC ENGINEERING DIVISION
 VARIOUS LOCALES AS INDICATED
 BY ORDER

DATE PRINTED	TERMS OF SALE	SHIP VIA	F.O.B	FREIGHT TERMS
04/16/2012				

BID OPENING DATE: 05/02/2012 BID OPENING TIME 01:30PM

LINE	QUANTITY	UOP	CAT NO	ITEM NUMBER	UNIT PRICE	AMOUNT
<p>RENEWAL: THIS CONTRACT MAY BE RENEWED UPON THE MUTUAL WRITTEN CONSENT OF THE SPENDING UNIT AND VENDOR, SUBMITTED TO THE DIRECTOR OF PURCHASING THIRTY (30) DAYS PRIOR TO THE EXPIRATION DATE. SUCH RENEWAL SHALL BE IN ACCORDANCE WITH THE TERMS AND CONDITIONS OF THE ORIGINAL CONTRACT AND SHALL BE LIMITED TO TWO (2) ONE (1) YEAR PERIODS.</p> <p>CANCELLATION: THE DIRECTOR OF PURCHASING RESERVES THE RIGHT TO CANCEL THIS CONTRACT IMMEDIATELY UPON WRITTEN NOTICE TO THE VENDOR IF THE COMMODITIES AND/OR SERVICE SUPPLIED ARE OF AN INFERIOR QUALITY OR DO NOT CONFORM TO THE SPECIFICATIONS OF THE BID AND CONTRACT HEREIN.</p> <p>OPEN MARKET CLAUSE: THE DIRECTOR OF PURCHASING MAY AUTHORIZE A SPENDING UNIT TO PURCHASE ON THE OPEN MARKET, WITHOUT THE FILING OF A REQUISITION OR COST ESTIMATE, ITEMS SPECIFIED ON THIS CONTRACT FOR IMMEDIATE DELIVERY IN EMERGENCIES DUE TO UNFORESEEN CAUSES (INCLUDING BUT NOT LIMITED TO DELAYS IN TRANSPORTATION OR AN UNANTICIPATED INCREASE IN THE VOLUME OF WORK.)</p> <p>QUANTITIES: QUANTITIES LISTED IN THE REQUISITION ARE APPROXIMATIONS ONLY, BASED ON ESTIMATES SUPPLIED BY THE STATE SPENDING UNIT. IT IS UNDERSTOOD AND AGREED THAT THE CONTRACT SHALL COVER THE QUANTITIES ACTUALLY ORDERED FOR DELIVERY DURING THE TERM OF THE CONTRACT, WHETHER MORE OR LESS THAN THE QUANTITIES SHOWN.</p> <p>ORDERING PROCEDURE: SPENDING UNIT(S) SHALL ISSUE A WRITTEN STATE CONTRACT ORDER (FORM NUMBER WV-39) TO THE VENDOR FOR COMMODITIES COVERED BY THIS CONTRACT. THE ORIGINAL COPY OF THE WV-39 SHALL BE MAILED TO THE VENDOR AS AUTHORIZATION FOR SHIPMENT, A SECOND COPY</p>						

SEE REVERSE SIDE FOR TERMS AND CONDITIONS

SIGNATURE	TELEPHONE	DATE
TITLE	FEIN	ADDRESS CHANGES TO BE NOTED ABOVE

WHEN RESPONDING TO RFQ, INSERT NAME AND ADDRESS IN SPACE ABOVE LABELED 'VENDOR'



State of West Virginia
 Department of Administration
 Purchasing Division
 2019 Washington Street East
 Post Office Box 50130
 Charleston, WV 25305-0130

Request for Quotation

RFQ NUMBER
8512C2040

PAGE
3

ADDRESS CORRESPONDENCE TO ATTENTION OF
ALAN CUMMINGS 304-558-2402

RFQ COPY
 TYPE NAME/ADDRESS HERE

VENDOR

SHIP TO

DIVISION OF HIGHWAYS
 TRAFFIC ENGINEERING DIVISION
 VARIOUS LOCALES AS INDICATED
 BY ORDER

DATE PRINTED	TERMS OF SALE	SHIP VIA	F.O.B.	FREIGHT TERMS
04/16/2012				

BID OPENING DATE: 05/02/2012 BID OPENING TIME 01:30PM

LINE	QUANTITY	UOP	CAT NO.	ITEM NUMBER	UNIT PRICE	AMOUNT
<p>MAILED TO THE PURCHASING DIVISION, AND A THIRD COPY RETAINED BY THE SPENDING UNIT.</p> <p>BANKRUPTCY: IN THE EVENT THE VENDOR/CONTRACTOR FILES FOR BANKRUPTCY PROTECTION, THE STATE MAY DEEM THE CONTRACT NULL AND VOID, AND TERMINATE SUCH CONTRACT WITHOUT FURTHER ORDER.</p> <p>THE TERMS AND CONDITIONS CONTAINED IN THIS CONTRACT SHALL SUPERSEDE ANY AND ALL SUBSEQUENT TERMS AND CONDITIONS WHICH MAY APPEAR ON ANY ATTACHED PRINTED DOCUMENTS SUCH AS PRICE LISTS, ORDER FORMS, SALES AGREEMENTS OR MAINTENANCE AGREEMENTS, INCLUDING ANY ELECTRONIC MEDIUM SUCH AS CD-ROM.</p> <p>REV. 01/17/2012 EXHIBIT 4</p> <p>LOCAL GOVERNMENT BODIES: UNLESS THE VENDOR INDICATES IN THE BID HIS REFUSAL TO EXTEND THE PRICES, TERMS, AND CONDITIONS OF THE BID TO COUNTY, SCHOOL, MUNICIPAL AND OTHER LOCAL GOVERNMENT BODIES, THE BID SHALL EXTEND TO POLITICAL SUBDIVISIONS OF THE STATE OF WEST VIRGINIA. IF THE VENDOR DOES NOT WISH TO EXTEND THE PRICES, TERMS, AND CONDITIONS OF THE BID TO ALL POLITICAL SUBDIVISIONS OF THE STATE, THE VENDOR MUST CLEARLY INDICATE SUCH REFUSAL IN HIS BID. SUCH REFUSAL SHALL NOT PREJUDICE THE AWARD OF THIS CONTRACT IN ANY MANNER.</p> <p>REV. 3/88 PURCHASING CARD ACCEPTANCE: THE STATE OF WEST VIRGINIA CURRENTLY UTILIZES A VISA PURCHASING CARD PROGRAM WHICH IS ISSUED THROUGH A BANK. THE SUCCESSFUL VENDOR MUST ACCEPT THE STATE OF WEST VIRGINIA VISA PURCHASING CARD FOR PAYMENT OF ALL ORDERS PLACED BY ANY STATE</p>						

SEE REVERSE SIDE FOR TERMS AND CONDITIONS

SIGNATURE	TELEPHONE	DATE
TITLE	FEIN	ADDRESS CHANGES TO BE NOTED ABOVE

WHEN RESPONDING TO RFQ, INSERT NAME AND ADDRESS IN SPACE ABOVE LABELED 'VENDOR'



State of West Virginia
 Department of Administration
 Purchasing Division
 2019 Washington Street East
 Post Office Box 50130
 Charleston, WV 25305-0130

Request for Quotation

RFQ NUMBER
8512C2040

PAGE
4

ADDRESS CORRESPONDENCE TO ATTENTION OF:
ALAN CUMMINGS 304-558-2402

VENDOR

RFQ COPY
 TYPE NAME/ADDRESS HERE

SHIP TO

DIVISION OF HIGHWAYS
 TRAFFIC ENGINEERING DIVISION
 VARIOUS LOCALES AS INDICATED
 BY ORDER

DATE PRINTED	TERMS OF SALE	SHIP VIA	F.O.B	FREIGHT TERMS
04/16/2012				

BID OPENING DATE: 05/02/2012 BID OPENING TIME 01:30PM

LINE	QUANTITY	UOP	CAT NO	ITEM NUMBER	UNIT PRICE	AMOUNT
<p>AGENCY AS A CONDITION OF AWARD.</p> <p>NOTICE</p> <p>A SIGNED BID MUST BE SUBMITTED TO:</p> <p>DEPARTMENT OF ADMINISTRATION PURCHASING DIVISION BUILDING 15 2019 WASHINGTON STREET, EAST CHARLESTON, WV 25305-0130</p> <p>THE BID SHOULD CONTAIN THIS INFORMATION ON THE FACE OF THE ENVELOPE OR THE BID MAY NOT BE CONSIDERED:</p> <p>SEALED BID</p> <p>BUYER: ALAN CUMMINGS - FILE 33</p> <p>RFQ. NO.: 8512C2040</p> <p>BID OPENING DATE: 05/02/2012</p> <p>BID OPENING TIME: 1:30 P.M.</p> <p>PLEASE PROVIDE A FAX NUMBER IN CASE IT IS NECESSARY TO CONTACT YOU REGARDING YOUR BID:</p> <p>-----</p>						

SEE REVERSE SIDE FOR TERMS AND CONDITIONS

SIGNATURE	TELEPHONE	DATE
TITLE	FEIN	ADDRESS CHANGES TO BE NOTED ABOVE

WHEN RESPONDING TO RFQ, INSERT NAME AND ADDRESS IN SPACE ABOVE LABELED 'VENDOR'



State of West Virginia
 Department of Administration
 Purchasing Division
 2019 Washington Street East
 Post Office Box 50130
 Charleston, WV 25305-0130

Request for Quotation

RFQ NUMBER
8512C2040

PAGE
5

ADDRESS CORRESPONDENCE TO ATTENTION OF:
ALAN CUMMINGS 304-558-2402

RFQ COPY
TYPE NAME/ADDRESS HERE

V
E
N
D
O
R

S
H
I
P
T
O

DIVISION OF HIGHWAYS
 TRAFFIC ENGINEERING DIVISION
 VARIOUS LOCALES AS INDICATED
 BY ORDER

DATE PRINTED	TERMS OF SALE	SHIP VIA	F.O.B	FREIGHT TERMS
04/16/2012				

BID OPENING DATE: **05/02/2012** BID OPENING TIME **01:30PM**

LINE	QUANTITY	UOP	CAT NO.	ITEM NUMBER	UNIT PRICE	AMOUNT
CONTACT PERSON (PLEASE PRINT CLEARLY):						

ANY INDIVIDUAL SIGNING THIS BID IS CERTIFYING THAT: (1) HE OR SHE IS AUTHORIZED BY THE BIDDER TO EXECUTE THE BID OR ANY DOCUMENTS RELATED THERETO ON BEHALF OF THE BIDDER, (2) THAT HE OR SHE IS AUTHORIZED TO BIND THE BIDDER IN A CONTRACTUAL RELATIONSHIP, AND (3) THAT THE BIDDER HAS PROPERLY REGISTERED WITH ANY STATE AGENCIES THAT MAY REQUIRE REGISTRATION.						
***** THIS IS THE END OF RFQ 8512C2040 ***** TOTAL:						_____

SEE REVERSE SIDE FOR TERMS AND CONDITIONS

SIGNATURE	TELEPHONE	DATE
-----------	-----------	------

TITLE	FEIN	ADDRESS CHANGES TO BE NOTED ABOVE
-------	------	-----------------------------------

WHEN RESPONDING TO RFQ, INSERT NAME AND ADDRESS IN SPACE ABOVE LABELED 'VENDOR'

Specifications

Purpose: The purpose of this contract shall be to furnish materials required for the maintenance of Energy Absorption System Energite III Sand Barrels, Energy Absorption System Fitch Sand Barrels, Plastic Safety Systems CrashGard Sand Barrels, and Traffix Devices Sand Barrels.

1.0 DEFINITIONS

- A. The "Agency" shall be defined as the West Virginia Division of Highways
- B. The "Vendor" shall be defined as the successful bidder.
- C. The "Contract" shall be defined as the binding agreement that is entered into between the State of West Virginia and the Vendor to provide the services as herein specified.
- D. "Release Order" shall be defined as order placed against the Contract by the Agency.
- E. Mandatory Requirements: The terms "must", "will", "shall", "minimum", "maximum", or "is/are required" identify a mandatory item or factor. Decisions regarding compliance with any mandatory requirements shall be at the sole discretion of the State.

2.0 SCOPE OF WORK

2.1 Technical Requirements: The successful Vendor shall provide complete sand barrel units and replacement lids for either the Energy Absorption System Energite III Sand Barrel system, the Energy Absorption System Fitch Sand Barrel system, the Plastic Safety Systems CrashGard Sand Barrel system, or the Traffix Devices Sand Barrel system.

2.1.1 Complete descriptions of the components to be supplied are included as part of the bid schedule. The bid schedule also includes references to the appropriate manufacturer installation drawing, also included as part of this Contract for reference.

2.1.2 Approved Products Listing

2.1.2.1 The individual sand barrel systems listed within this RFQ are sand barrel systems currently listed on the WVDOH APL. A copy of the current APL may be viewed at the website <http://www.transportation.wv.gov/highways/mcst/Documents/APPROVED%20PRODUCTS%20LIST%20traffic%20safety%20devices%202011-12.pdf> (see Type V category).

2.1.2.2 The Approved Products List establishes a list of “certified” manufacturers that meet the acceptable level of quality and is not intended to reflect a preference or favor any particular brand or Vendor. Any manufacturer capable of meeting the established level of quality may become an “certified” manufacturer and be added to the APL in accordance with the procedures found in MP (Materials Procedure) MP 700.00.55 Guidelines for Establishing Approved Lists of Materials and Sources. A copy of MP 700.00.55 may be found at:

<http://www.transportation.wv.gov/highways/mcst/Pages/MaterialProcedures.aspx>

The state reserves the right to waive minor irregularities in bids or specifications in accordance with section 148-1-4(F) of the West Virginia Legislative Rules and Regulations.

2.2 Delivery

2.2.1 This Contract may be utilized by multiple recipients statewide, each having a unique delivery address.

2.2.2 Release Orders shall be delivered in full within a maximum of twenty-one (21) Calendar Days ARO. If the Vendor is unable to deliver in full within twenty-one (21) Calendar Days, the Vendor shall be subject to a daily (per Calendar Day) penalty at the purchasing organizations discretion for each Calendar Day beyond twenty-one (21) Calendar Days ARO, until the order is received in full. This penalty shall be assessed by subtracting the penalty from the original total value of the Release Order. The penalty shall not exceed the original total amount of the Release Order. The penalty shall be calculated based on the Table shown at the following address:

<http://www.transportation.wv.gov/highways/contractadmin/specifications/Pages/LiquidDatedDamages.aspx>

The original total amount of the Release Order shall be substituted for the “Original Contract Amount” when using this Table

2.2.3 All large components shall be shipped adequately secured on pallets for ease in unloading. Large components shall be easily identifiable or the packaging shall be labeled indicating the contained parts. All accessory hardware and relatively small components shall be appropriately packaged and labeled. Any material delivered not meeting the above requirements shall be subject to being returned to

the Vendor at the Vendor's expense. In this case, the Vendor shall be responsible for the shipment of the returned materials back to the purchasing organization, packaged as specified above. In addition, the provisions of 2.2.2 shall remain in effect. The order shall be considered "delivered in full" at the time of delivery of the returned materials back to the purchasing organization. Furthermore, the number of days for completion of the order shall be calculated as specified in 2.2.2. If expedited delivery was requested for the order, the provisions of Section 4.2.3 shall apply to the entire order if the returned materials are not delivered back to the purchasing organization within ten (10) Calendar Days of the original receipt of the order by the Vendor.

2.2.4 Delivery is an integral part of this contract and failure to comply will be cause to initiate a WV-82, Vendor Performance Form. This form will officially notify the West Virginia Division of Purchasing and the Vendor of unsatisfactory performance in the execution of this contract and the requirements herein.

3.0 FREIGHT

3.1 All shipments are to be FOB Destination.

3.2 The Vendor shall be responsible for all freight charges incurred as a result of the purchases under this Contract. For orders where expedited delivery is requested and authorized by the Agency, the Vendor may invoice for these charges provided that it will be given as a "pass through" cost to the Agency. No markup shall be permitted for expedited delivery. See Section 4.2.3 for more information.

4.0 ORDERING AND INVOICING

4.1 Release Orders

4.1.1 For all orders, the Agency will issue to the Vendor a WV-39 Release Order. Issuance of the Release Order shall contain the type of merchandise to be purchased and shall serve as the authorization to process the order.

4.2 Payment

4.2.1 The State of West Virginia currently utilizes a VISA purchasing card program which is issued through a local bank. The Vendor must accept the State of West Virginia purchasing card for payment of all orders placed against this Contract.

4.2.2 The Vendor must supply a credit card receipt, sales receipt, or cash register receipt. In addition, all orders shall be shipped with an itemized packing list(s). The packing list(s) shall show all items included in the shipment as well as items on backorder. Charges must not be applied until all merchandise on the WV-39 Release Order is received in full by the Agency.

4.2.3 For orders where expedited delivery has been requested by the Agency per Section 3.2, the Vendor may add actual shipping costs (prepaid) to the invoice as a separate item. In this case, the Vendor shall attach a copy of the freight bill to the invoice sent to the Agency. All such orders shall be delivered in full within ten (10) Calendar Days ARO. If any such order is not received in full within ten (10) Calendar Days ARO, the Vendor may not add shipping costs as described above to the invoice and the order will be treated as a normal non-expedited order with the provisions of Section 2.2.2 to apply.

5.0 CONTRACT STRUCTURE & CONTRACT BID EVALUATION

5.1 Contract Sections

5.1.1 This Contract shall be considered to consist of four (4) Sections. Section I consists of Items 1 through 3. Section II consists of Items 4 through 5. Section III consists of Items 6 through 9. Section IV consists of Items 10 and 11.

5.2 Bidding & Award

5.2.1 The Vendor should choose and provide pricing for only one (1) of the Sections described above. If the Vendor provides pricing for more than one (1) Section, the "total cost" for each Section shall be calculated separately. The total cost for each Section shall be the total of the values in the "TOTAL AMOUNT" column in each Section. The Section with the lowest total cost will be the Section considered to be the one (1) Section that the Vendor is bidding on the Contract, and will be considered the "total cost" of the Vendor's bid.

5.2.2 The Vendor with the lowest "total cost" associated with their bid will be awarded the Contract. Only one Section shall be awarded, and only one Vendor shall be awarded the Contract. The Vendor must provide a price for all items in one (1) Section of the Contract or their bid will be disqualified.

Energit® III/ Fitch® Universal Module Systems

Figure IA-Energit® III

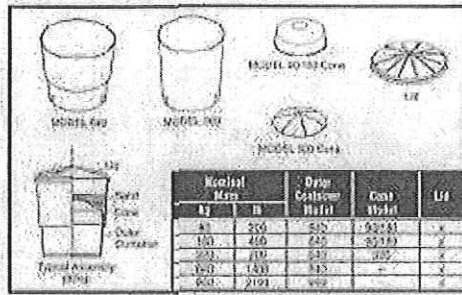

Energit III System Components

Crash Performance

The Energit® III/Fitch® Universal Module Systems have been successfully tested to NCHRP Report 350, Test Level 3 for non-redirective, gating crash cushions. NCHRP 350 differs from NCHRP 230 in that the heavy vehicle is now a pickup truck with a higher center-of-gravity plus the impact severity has increased by 6.7% due to the impact speed of 100 km/h (62 mph).

The inertial barrel systems break up during impact. As the impacting vehicle passes through the array, its speed is slowed by transfer of its momentum to the sand, allowing for safe, steady deceleration.

Caution: Inertial barrels are not recommended for sites where redirective capabilities are warranted.

Figure IB-Fitch® Universal Module System

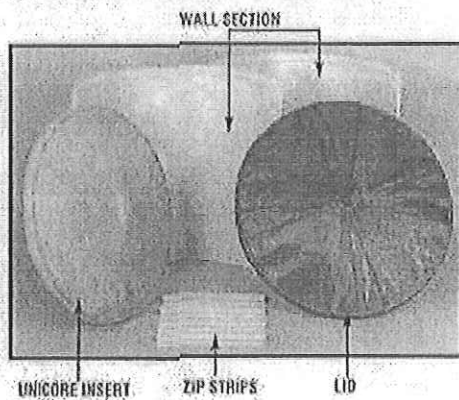
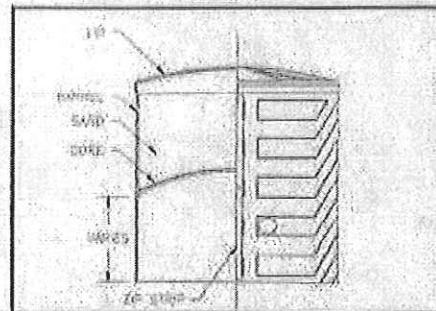
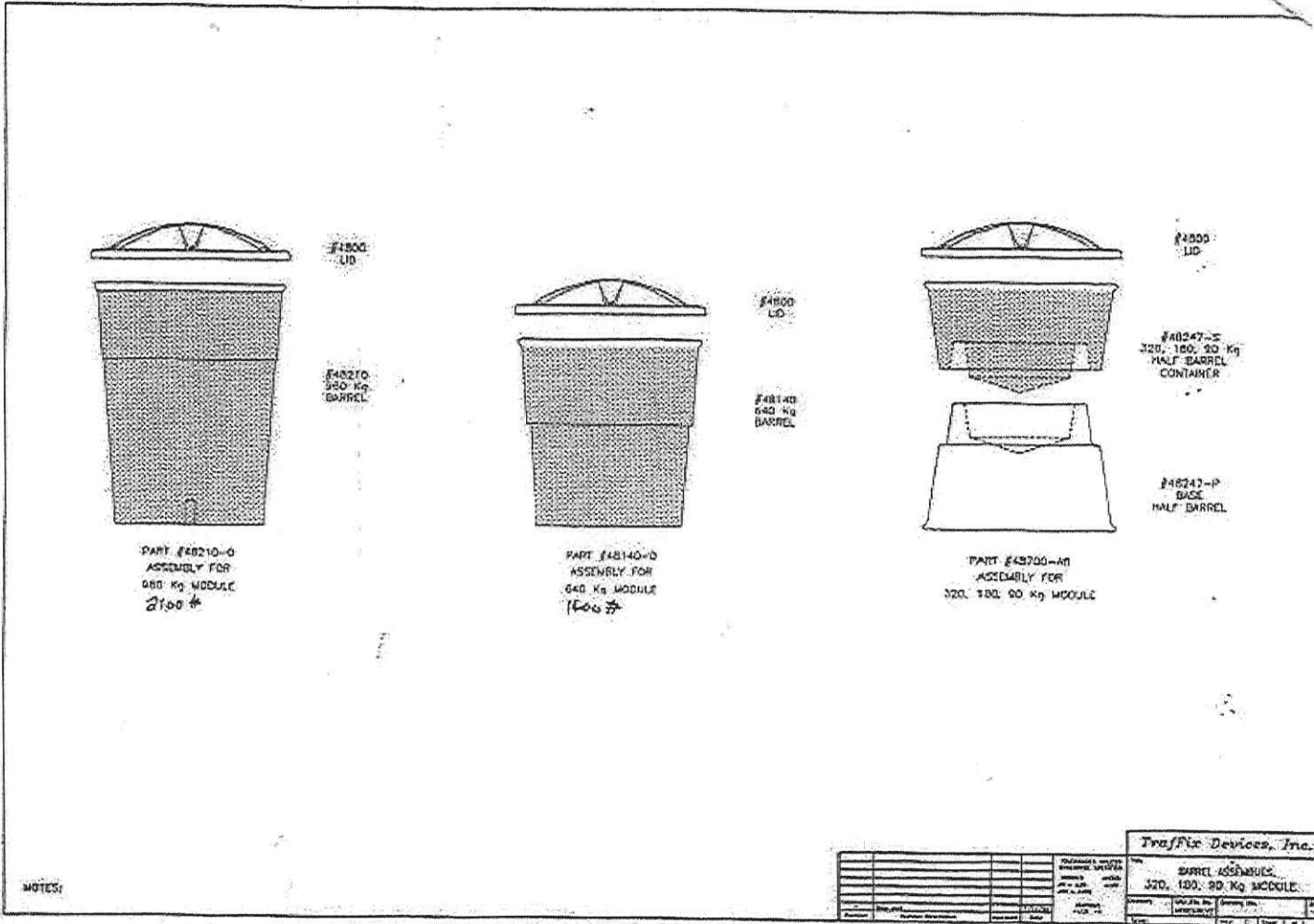

Figure IC-Fitch® Universal Module System



2



NOTES:

Traffic Devices, Inc.	
Part No.	#48200-00
Description	BARREL ASSEMBLY 320, 180, 90 Kg MODULE
Quantity	1
Unit	EA
Material	Steel
Finish	Galv. Steel
Weight	1600 #
Volume	
Drawn By	
Checked By	
Approved By	
Date	

NOTE THAT THERE IS NOW ONLY **ONE** SAND CONTAINER FOR 200LB, 400LB & 700LB

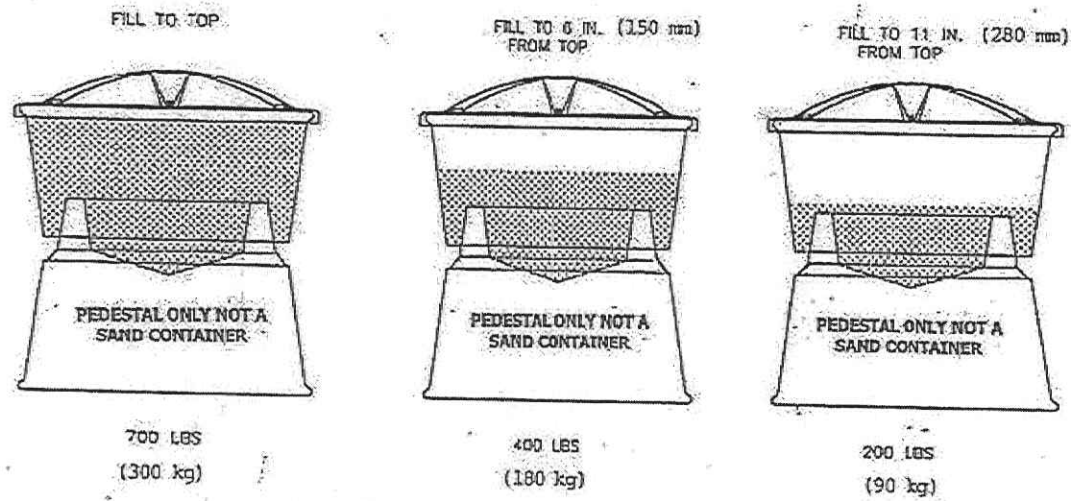

3

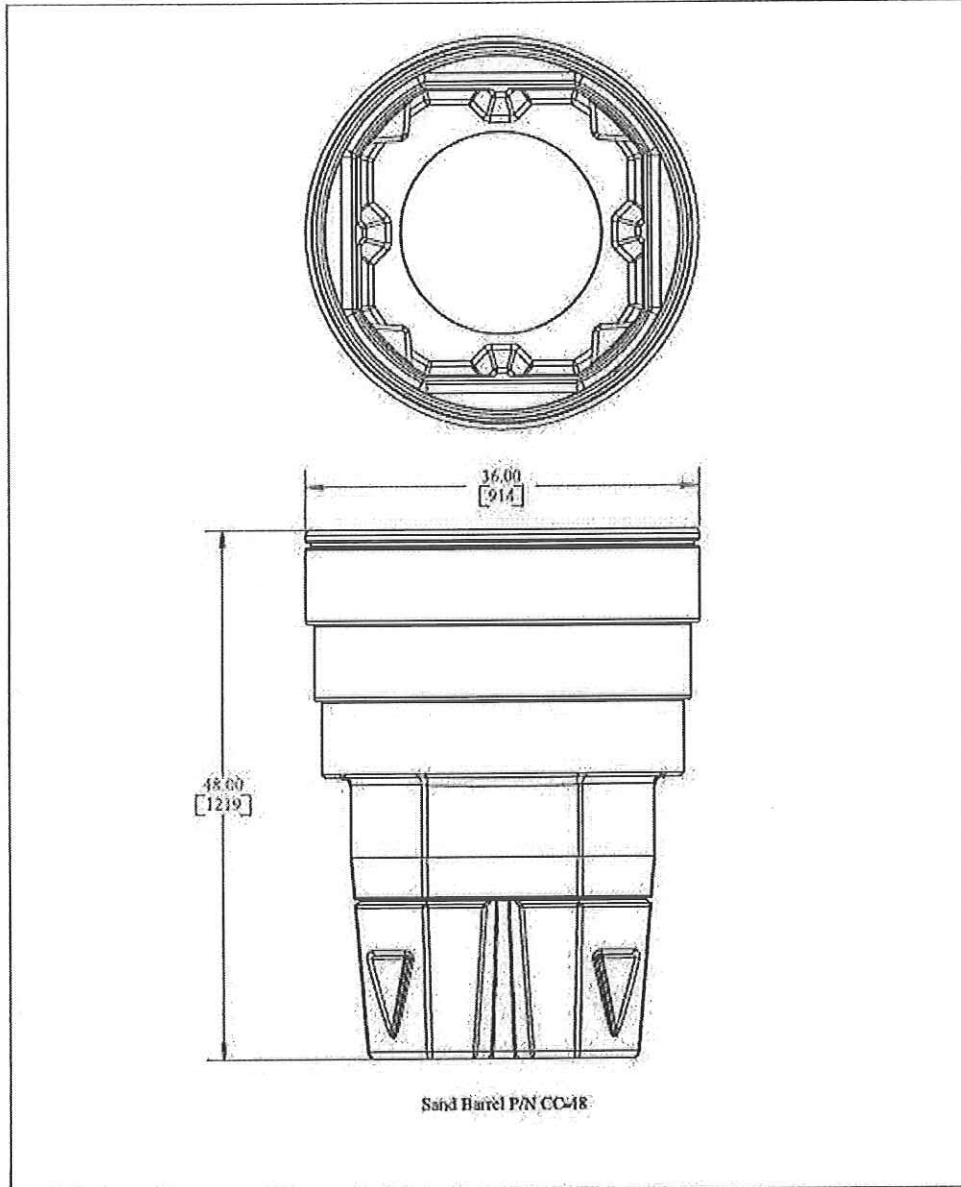

Sand Barrel P/N CC-18

CrashGard Sand Barrel

Plastic Safety Systems, Inc.

Designator
to be assigned

SHEET NO.
4 of 6

DATE:
1/19/07

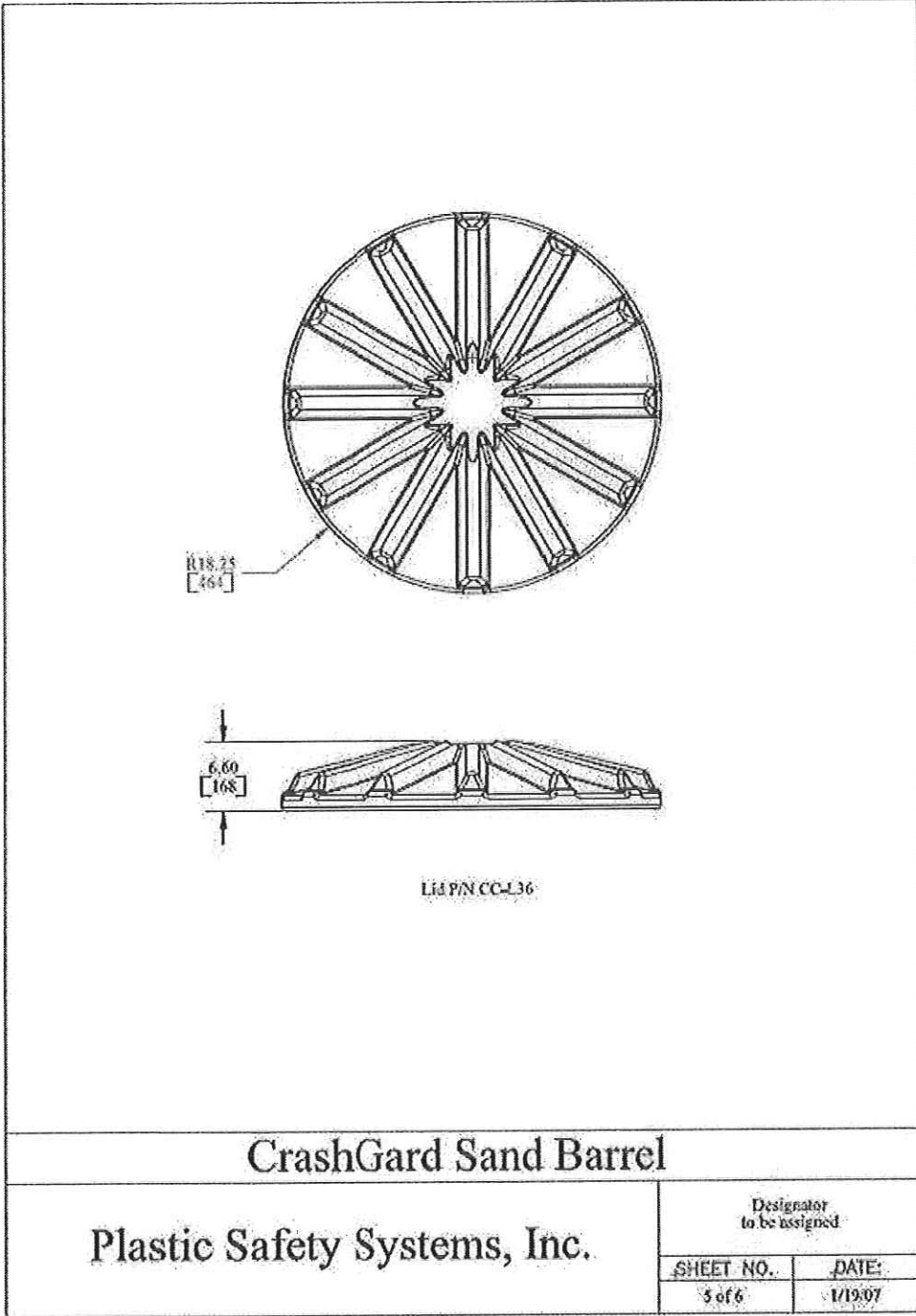

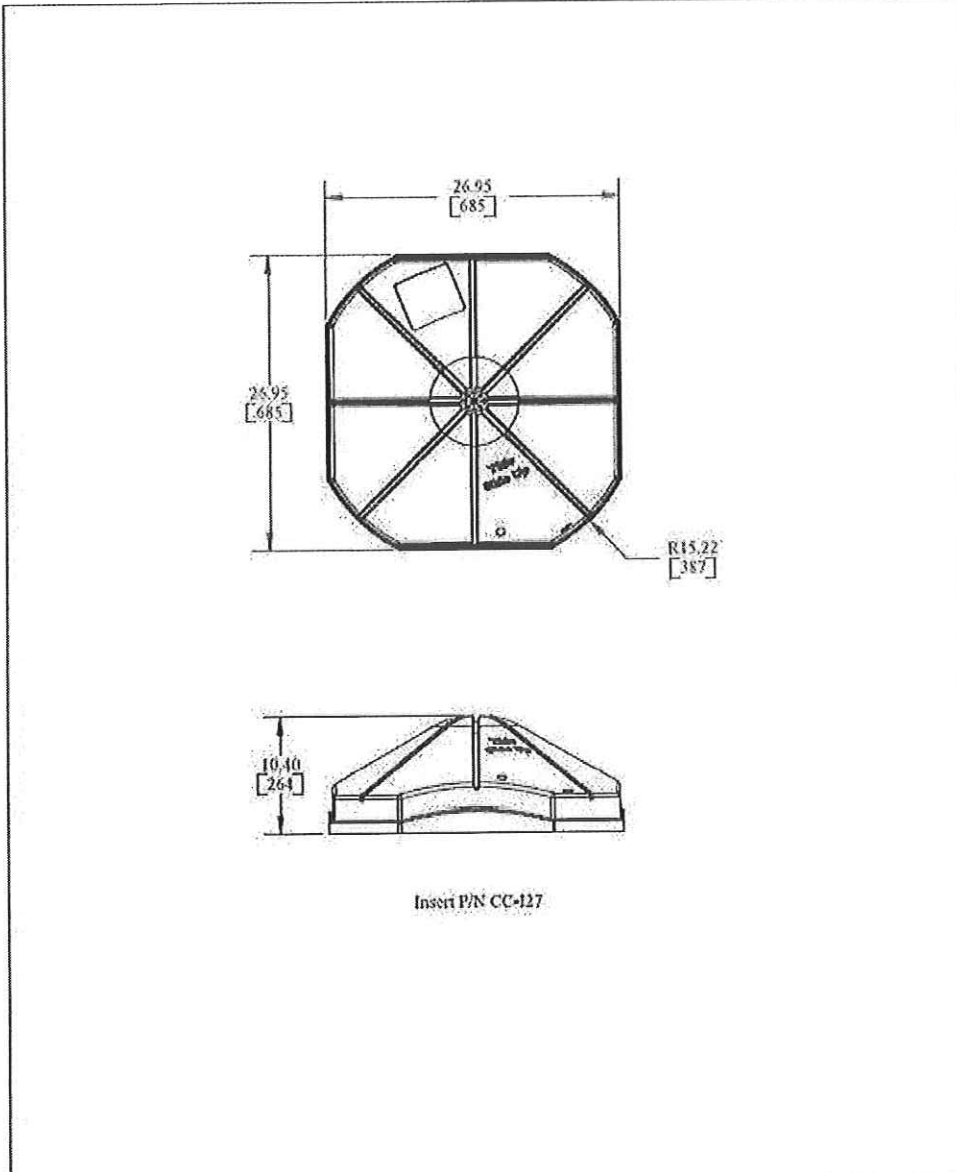

CrashGard Sand Barrel

Plastic Safety Systems, Inc.	Designator to be assigned	
	SHEET NO. 6 of 6	DATE: 1/19/07

TYPICAL WVDOH DELIVERY POINTS, DELIVERY CONTACTS, AND INVOICING ADDRESSES

Delivery Address	Delivery Contact	Delivery Contact Phone Number	Invoicing Address
WVDOH - D1 Sign Shop 75 Pickens Rd. Nitro, WV 25143	Mike Priddy	304-759-0708 304-558-3001*	WVDOH - D1 Headquarters 1334 Smith Street Charleston, WV 25301
WVDOH - D2 Sign Shop 801 Madison Ave. Huntington, WV 25704	Dale Kennedy	304-528-5906 304-528-5600*	WVDOH - D2 Headquarters 801 Madison Avenue Huntington, WV 25712
WVDOH - D3 Sign Shop 720 Depot St. Parkersburg, WV 26101	Tom Potts	304-420-4815 304-420-4645*	WVDOH - D3 Headquarters 624 Depot Street Parkersburg, WV 26102
WVDOH - D4 Sign Shop US-19 - 1 mile N. of Clarksburg (gore yard) Clarksburg, WV 26301	Rick Reed	304-627-2401 304-842-1500*	WVDOH - D4 Headquarters I-79 & Meadowbrook Road Clarksburg, WV 26302
WVDOH - D5 Sign Shop US-50 - 14 miles E. of Keyser Burlington, WV 26710	Doug Placka	304-289-3521 304-289-3521*	WVDOH - D5 Headquarters P.O. Box 99 (Route 50) Burlington, WV 26710
WVDOH District 6 Sign Shop 1 DOT Drive, Bldg. 3 Moundsville, WV 26041	Jim Wurtzbacher	304-843-3658 304-238-4008*	WVDOH - D6 Headquarters 1 DOT Drive Moundsville, WV 26041
WVDOH - D7 Sign Shop US-33 - 1/2 mile E. of Weston Weston, WV 26452	Tyrone Campbell	304-269-0460 304-269-0414*	WVDOH - D7 Headquarters 255 Depot Street Weston, WV 26452
WVDOH - D8 Sign Shop Rt. 219 - 1 mile N. of Elkins Elkins, WV 26241	Mike Westfall	304-637-0215 304-637-0220*	WVDOH - D8 Headquarters US 219 North Elkins, WV 26241
WVDOH - D9 Sign Shop US-219 - 1-1/2 miles N. of Lewisburg Country Club Rd. - Brush Rd. Lewisburg, WV 24901	Harry Perkins	304-647-7551 304-647-7450*	WVDOH - D9 Headquarters 103 1/2 Church Street Lewisburg, WV 24901
WVDOH - D10 Sign Shop 270 Hardwood Lane Princeton, WV 24740	Curtis Whitlow	304-487-5283 304-487-5228*	WVDOH - D10 Headquarters 270 Hardwood Lane Princeton, WV 24740
WVDOH - Traffic Services Complex 180 Dry Branch Rd. Charleston, WV 25306	Chuck Swigger Bruce Miller	304-558-6356 304-558-9454	WVDOH - Traffic Engineering Div. Bldg. 5 - Room A550 1900 Kanawha Blvd. E. Charleston, WV 25305

* District/Division headquarters phone number

BID SCHEDULE

Quantities listed in this RFQ are approximations only. It is understood and agreed that the contract shall cover the quantities actually ordered for delivery during the term of the contract, whether more or less than the quantities shown. Award will be based on lowest total cost.

ITEM NUMBER	UNIT OF MEASURE	ESTIMATED QUANTITY	DESCRIPTION	PART DETAIL SHEET(S)	UNIT PRICE	EXTENDED TOTAL AMOUNT	(DOH USE ONLY) INVENTORY SUBCODE
			Energy Absorption Systems Energite III Sand Barrels				
1	EA.	18	Energite III complete barrel, 200# through 1400# (includes container, lid, and insert. Specify [200# - 400#] or [700#] insert to be supplied with barrel)	1			511000
2	EA.	8	Energite III complete barrel, 2100# (includes container and lid)	1			512000
3	EA.	1	Energite III lid	1			513000
			Energy Absorption Systems Fitch Sand Barrels				
4	EA.	26	Fitch complete barrel , 200#, 400#, 700#, 1400#, 2100# (includes container, zip strips, lid, and Unicore insert)	1			521000
5	EA.	1	Fitch lid	1			522000
			Traffic Devices Sand Barrels				
6	EA.	10	Traffic Devices complete barrel, 200# through 700# (includes pedestal, sand container, and lid)	2, 3			531000
7	EA.	8	Traffic Devices complete barrel, 1400# (includes lid)	2, 3			532000
8	EA.	8	Traffic Devices complete barrel, 2100# (includes lid)	2, 3			533000
9	EA.	1	Traffic Devices lid	2, 3			534000

BID SCHEDULE (CONTINUED)

ITEM NUMBER	UNIT OF MEASURE	ESTIMATED QUANTITY	DESCRIPTION	PART DETAIL SHEET(S)	UNIT PRICE	EXTENDED TOTAL AMOUNT	(DOH USE ONLY) INVENTORY SUBCODE
			Plastic Safety Systems CrashGard Sand Barrels				
10	EA.	26	PSS complete barrel, 200#, 400#, 700#, 1400#, 2100# (includes barrel P/N CC-48, lid P/N CC-L36, and insert P/N CC-I27	4, 5, 6			
11	EA.	1	PSS lid P/N CC-L36	5			
CONTRACT TOTAL						—————>	

WVDOH PERSONNEL

An online form is in place in order for District personnel to submit a documented report to the Traffic Engineering Division regarding issues associated with material orders. This form is intended to serve as a manner in which District personnel may quickly and easily submit a documented report to the Traffic Engineering Division regarding issues associated with ordering, delivery and receipt, quality, or order reconciliation issues associated with any of the materials ordered. This form may also be used to report issues with the installation or post-installation performance of materials. This form is located in the "Traffic" section of the WVDOH intranet site (Click on "Traffic" on the left side of the page, then click on "PO Contract Report" on the left side of the page). The direct address for the location of this form is <http://sharepoint.wv.gov/sites/dot/highways/traffic/pocontractreport/Pages/default.aspx>. Once the report is submitted, an email verification will be automatically sent and an email notice will be sent to the Traffic Engineering Division. All reports submitted will be responded to by the Traffic Engineering Division. The Traffic Engineering Division will work with the individual at the District submitting the report to obtain additional needed facts or documentation such as photos or product samples, and will contact and work with the Contract Vendor and Materials Division if needed in order to reconcile the issues in a manner acceptable to all parties if possible. Typically, as a final step to address reported issues, the Traffic Engineering Division will complete and submit a WV-82 Vendor Performance Form in order to officially document any issues and their outcome. The initial point of contact for any submitted reports is Bruce Miller. If you have any questions or would like to follow up on the status of a report that has been submitted, please contact Mr. Miller at 558-9454 or bruce.f.miller@wv.gov.

State of West Virginia

VENDOR PREFERENCE CERTIFICATE

Certification and application* is hereby made for Preference in accordance with West Virginia Code, §5A-3-37. (Does not apply to construction contracts). West Virginia Code, §5A-3-37, provides an opportunity for qualifying vendors to request (at the time of bid) preference for their residency status. Such preference is an evaluation method only and will be applied only to the cost bid in accordance with the West Virginia Code. This certificate for application is to be used to request such preference. The Purchasing Division will make the determination of the Resident Vendor Preference, if applicable.

- 1. Application is made for 2.5% resident vendor preference for the reason checked: Bidder is an individual resident vendor and has resided continuously in West Virginia for four (4) years immediately preceding the date of this certification; or, Bidder is a partnership, association or corporation resident vendor and has maintained its headquarters or principal place of business continuously in West Virginia for four (4) years immediately preceding the date of this certification; or 80% of the ownership interest of Bidder is held by another individual, partnership, association or corporation resident vendor who has maintained its headquarters or principal place of business continuously in West Virginia for four (4) years immediately preceding the date of this certification; or, Bidder is a nonresident vendor which has an affiliate or subsidiary which employs a minimum of one hundred state residents and which has maintained its headquarters or principal place of business within West Virginia continuously for the four (4) years immediately preceding the date of this certification; or,
2. Application is made for 2.5% resident vendor preference for the reason checked: Bidder is a resident vendor who certifies that, during the life of the contract, on average at least 75% of the employees working on the project being bid are residents of West Virginia who have resided in the state continuously for the two years immediately preceding submission of this bid; or,
3. Application is made for 2.5% resident vendor preference for the reason checked: Bidder is a nonresident vendor employing a minimum of one hundred state residents or is a nonresident vendor with an affiliate or subsidiary which maintains its headquarters or principal place of business within West Virginia employing a minimum of one hundred state residents who certifies that, during the life of the contract, on average at least 75% of the employees or Bidder's affiliate's or subsidiary's employees are residents of West Virginia who have resided in the state continuously for the two years immediately preceding submission of this bid; or,
4. Application is made for 5% resident vendor preference for the reason checked: Bidder meets either the requirement of both subdivisions (1) and (2) or subdivision (1) and (3) as stated above; or,
5. Application is made for 3.5% resident vendor preference who is a veteran for the reason checked: Bidder is an individual resident vendor who is a veteran of the United States armed forces, the reserves or the National Guard and has resided in West Virginia continuously for the four years immediately preceding the date on which the bid is submitted; or,
6. Application is made for 3.5% resident vendor preference who is a veteran for the reason checked: Bidder is a resident vendor who is a veteran of the United States armed forces, the reserves or the National Guard, if, for purposes of producing or distributing the commodities or completing the project which is the subject of the vendor's bid and continuously over the entire term of the project, on average at least seventy-five percent of the vendor's employees are residents of West Virginia who have resided in the state continuously for the two immediately preceding years.

Bidder understands if the Secretary of Revenue determines that a Bidder receiving preference has failed to continue to meet the requirements for such preference, the Secretary may order the Director of Purchasing to: (a) reject the bid; or (b) assess a penalty against such Bidder in an amount not to exceed 5% of the bid amount and that such penalty will be paid to the contracting agency or deducted from any unpaid balance on the contract or purchase order.

By submission of this certificate, Bidder agrees to disclose any reasonably requested information to the Purchasing Division and authorizes the Department of Revenue to disclose to the Director of Purchasing appropriate information verifying that Bidder has paid the required business taxes, provided that such information does not contain the amounts of taxes paid nor any other information deemed by the Tax Commissioner to be confidential.

Under penalty of law for false swearing (West Virginia Code, §61-5-3), Bidder hereby certifies that this certificate is true and accurate in all respects; and that if a contract is issued to Bidder and if anything contained within this certificate changes during the term of the contract, Bidder will notify the Purchasing Division in writing immediately.

Bidder: _____ Signed: _____

Date: _____ Title: _____

*Check any combination of preference consideration(s) indicated above, which you are entitled to receive.

STATE OF WEST VIRGINIA
Purchasing Division

PURCHASING AFFIDAVIT

West Virginia Code §5A-3-10a states: No contract or renewal of any contract may be awarded by the state or any of its political subdivisions to any vendor or prospective vendor when the vendor or prospective vendor or a related party to the vendor or prospective vendor is a debtor and the debt owed is an amount greater than one thousand dollars in the aggregate.

DEFINITIONS:

"Debt" means any assessment, premium, penalty, fine, tax or other amount of money owed to the state or any of its political subdivisions because of a judgment, fine, permit violation, license assessment, defaulted workers' compensation premium, penalty or other assessment presently delinquent or due and required to be paid to the state or any of its political subdivisions, including any interest or additional penalties accrued thereon.

"Debtor" means any individual, corporation, partnership, association, limited liability company or any other form or business association owing a debt to the state or any of its political subdivisions. "Political subdivision" means any county commission; municipality; county board of education; any instrumentality established by a county or municipality; any separate corporation or instrumentality established by one or more counties or municipalities, as permitted by law; or any public body charged by law with the performance of a government function or whose jurisdiction is coextensive with one or more counties or municipalities. "Related party" means a party, whether an individual, corporation, partnership, association, limited liability company or any other form or business association or other entity whatsoever, related to any vendor by blood, marriage, ownership or contract through which the party has a relationship of ownership or other interest with the vendor so that the party will actually or by effect receive or control a portion of the benefit, profit or other consideration from performance of a vendor contract with the party receiving an amount that meets or exceed five percent of the total contract amount.

EXCEPTION: The prohibition of this section does not apply where a vendor has contested any tax administered pursuant to chapter eleven of this code, workers' compensation premium, permit fee or environmental fee or assessment and the matter has not become final or where the vendor has entered into a payment plan or agreement and the vendor is not in default of any of the provisions of such plan or agreement.

Under penalty of law for false swearing (*West Virginia Code §61-5-3*), it is hereby certified that the vendor affirms and acknowledges the information in this affidavit and is in compliance with the requirements as stated.

WITNESS THE FOLLOWING SIGNATURE

Vendor's Name: _____

Authorized Signature: _____ Date: _____

State of _____

County of _____, to-wit:

Taken, subscribed, and sworn to before me this ____ day of _____, 20__.

My Commission expires _____, 20__.

AFFIX SEAL HERE

NOTARY PUBLIC. _____