



State of West Virginia
 Department of Administration
 Purchasing Division
 2019 Washington Street East
 Post Office Box 50130
 Charleston, WV 25305-0130

Request for Quotation

RFQ NUMBER
061200262

PAGE
1

ADDRESS CORRESPONDENCE TO ATTENTION OF:
ALAN CUMMINGS 304-558-2402

VENDOR

RFQ COPY
 TYPE NAME/ADDRESS HERE

SHIP TO

DIVISION OF HIGHWAYS
 DISTRICT SIX
 1 DOT DRIVE
 MOUNDSVILLE, WV
 26041 304-843-3656

DATE PRINTED	TERMS OF SALE	SHIP VIA	F.O.B.	FREIGHT TERMS
04/10/2012				

BID OPENING DATE: 04/25/2012 BID OPENING TIME 01:30PM

LINE	QUANTITY	UOP	CAT. NO.	ITEM NUMBER	UNIT PRICE	AMOUNT
0001	1	LS		400-15		
ALUMINUM BRIDGE RAILING						
<p>THE WEST VIRGINIA STATE PURCHASING DIVISION FOR THE AGENCY, THE WEST VIRGINIA DIVISION OF HIGHWAYS, IS SOLICITING BIDS TO PROVIDE THE AGENCY WITH THE REPLACEMENT OF ALUMINUM BRIDGE RAILING ON THE BENWOOD BRIDGE PER THE ATTACHED SPECIFICATIONS.</p> <p>CANCELLATION: THE DIRECTOR OF PURCHASING RESERVES THE RIGHT TO CANCEL THIS CONTRACT IMMEDIATELY UPON WRITTEN NOTICE TO THE VENDOR IF THE COMMODITIES AND/OR SERVICES SUPPLIED ARE OF AN INFERIOR QUALITY OR DO NOT CONFORM TO THE SPECIFICATIONS OF THE BID AND CONTRACT HEREIN.</p> <p>BANKRUPTCY: IN THE EVENT THE VENDOR/CONTRACTOR FILES FOR BANKRUPTCY PROTECTION, THE STATE MAY DEEM THE CONTRACT NULL AND VOID, AND TERMINATE SUCH CONTRACT WITHOUT FURTHER ORDER.</p> <p>PURCHASING CARD ACCEPTANCE: THE STATE OF WEST VIRGINIA CURRENTLY UTILIZES A VISA PURCHASING CARD PROGRAM WHICH IS ISSUED THROUGH A BANK. THE SUCCESSFUL VENDOR MUST ACCEPT THE STATE OF WEST VIRGINIA VISA PURCHASING CARD FOR PAYMENT OF ALL ORDERS PLACED BY ANY STATE AGENCY AS A CONDITION OF AWARD.</p> <p style="text-align: center;">NOTICE</p> <p>A SIGNED BID MUST BE SUBMITTED TO:</p>						

SEE REVERSE SIDE FOR TERMS AND CONDITIONS

SIGNATURE	TELEPHONE	DATE
-----------	-----------	------

TITLE	FEIN	ADDRESS CHANGES TO BE NOTED ABOVE
-------	------	-----------------------------------

WHEN RESPONDING TO RFQ, INSERT NAME AND ADDRESS IN SPACE ABOVE LABELED 'VENDOR'

GENERAL TERMS & CONDITIONS REQUEST FOR QUOTATION (RFQ) AND REQUEST FOR PROPOSAL (RFP)

1. Awards will be made in the best interest of the State of West Virginia.
2. The State may accept or reject in part, or in whole, any bid.
3. Prior to any award, the apparent successful vendor must be properly registered with the Purchasing Division and have paid the required \$125 fee.
4. All services performed or goods delivered under State Purchase Order/Contracts are to be continued for the term of the Purchase Order/Contracts, contingent upon funds being appropriated by the Legislature or otherwise being made available. In the event funds are not appropriated or otherwise available for these services or goods this Purchase Order/Contract becomes void and of no effect after June 30.
5. Payment may only be made after the delivery and acceptance of goods or services.
6. Interest may be paid for late payment in accordance with the *West Virginia Code*.
7. Vendor preference will be granted upon written request in accordance with the *West Virginia Code*.
8. The State of West Virginia is exempt from federal and state taxes and will not pay or reimburse such taxes.
9. The Director of Purchasing may cancel any Purchase Order/Contract upon 30 days written notice to the seller.
10. The laws of the State of West Virginia and the *Legislative Rules* of the Purchasing Division shall govern the purchasing process.
11. Any reference to automatic renewal is hereby deleted. The Contract may be renewed only upon mutual written agreement of the parties.
12. **BANKRUPTCY:** In the event the vendor/contractor files for bankruptcy protection, the State may deem this contract null and void, and terminate such contract without further order.
13. **HIPAA BUSINESS ASSOCIATE ADDENDUM:** The West Virginia State Government HIPAA Business Associate Addendum (BAA), approved by the Attorney General, is available online at www.state.wv.us/admin/purchase/vrc/hipaa.html and is hereby made part of the agreement provided that the Agency meets the definition of a Cover Entity (45 CFR §160.103) and will be disclosing Protected Health Information (45 CFR §160.103) to the vendor.
14. **CONFIDENTIALITY:** The vendor agrees that he or she will not disclose to anyone, directly or indirectly, any such personally identifiable information or other confidential information gained from the agency, unless the individual who is the subject of the information consents to the disclosure in writing or the disclosure is made pursuant to the agency's policies, procedures, and rules. Vendor further agrees to comply with the Confidentiality Policies and Information Security Accountability Requirements, set forth in <http://www.state.wv.us/admin/purchase/privacy/noticeConfidentiality.pdf>.
15. **LICENSING:** Vendors must be licensed and in good standing in accordance with any and all state and local laws and requirements by any state or local agency of West Virginia, including, but not limited to, the West Virginia Secretary of State's Office, the West Virginia Tax Department, and the West Virginia Insurance Commission. The vendor must provide all necessary releases to obtain information to enable the director or spending unit to verify that the vendor is licensed and in good standing with the above entities.
16. **ANTITRUST:** In submitting a bid to any agency for the State of West Virginia, the bidder offers and agrees that if the bid is accepted the bidder will convey, sell, assign or transfer to the State of West Virginia all rights, title and interest in and to all causes of action it may now or hereafter acquire under the antitrust laws of the United States and the State of West Virginia for price fixing and/or unreasonable restraints of trade relating to the particular commodities or services purchased or acquired by the State of West Virginia. Such assignment shall be made and become effective at the time the purchasing agency tenders the initial payment to the bidder.

I certify that this bid is made without prior understanding, agreement, or connection with any corporation, firm, limited liability company, partnership, or person or entity submitting a bid for the same material, supplies, equipment or services and is in all respects fair and without collusion or Fraud. I further certify that I am authorized to sign the certification on behalf of the bidder or this bid.

INSTRUCTIONS TO BIDDERS

1. Use the quotation forms provided by the Purchasing Division. Complete all sections of the quotation form.
2. Items offered must be in compliance with the specifications. Any deviation from the specifications must be clearly indicated by the bidder. Alternates offered by the bidder as **EQUAL** to the specifications must be clearly defined. A bidder offering an alternate should attach complete specifications and literature to the bid. The Purchasing Division may waive minor deviations to specifications.
3. Unit prices shall prevail in case of discrepancy. All quotations are considered F.O.B. destination unless alternate shipping terms are clearly identified in the quotation.
4. All quotations must be delivered by the bidder to the office listed below prior to the date and time of the bid opening. Failure of the bidder to deliver the quotations on time will result in bid disqualifications: Department of Administration, Purchasing Division, 2019 Washington Street East, P.O. Box 50130, Charleston, WV 25305-0130
5. Communication during the solicitation, bid, evaluation or award periods, except through the Purchasing Division, is strictly prohibited (W.Va. C.S.R. §148-1-6.6).



State of West Virginia
 Department of Administration
 Purchasing Division
 2019 Washington Street East
 Post Office Box 50130
 Charleston, WV 25305-0130

Request for Quotation

RFQ NUMBER
061200262

PAGE
2

ADDRESS CORRESPONDENCE TO ATTENTION OF
ALAN CUMMINGS
304-558-2402

VENDOR

RFQ COPY
 TYPE NAME/ADDRESS HERE

SHIP TO

DIVISION OF HIGHWAYS
 DISTRICT SIX
 1 DOT DRIVE

 MOUNDSVILLE, WV
 26041 304-843-3656

DATE PRINTED	TERMS OF SALE	SHIP VIA	F.O.B.	FREIGHT TERMS
04/10/2012				

BID OPENING DATE: **04/25/2012** BID OPENING TIME **01:30PM**

LINE	QUANTITY	UOP	CAT. NO.	ITEM NUMBER	UNIT PRICE	AMOUNT
DEPARTMENT OF ADMINISTRATION PURCHASING DIVISION BUILDING 15 2019 WASHINGTON STREET, EAST CHARLESTON, WV 25305-0130						
THE BID SHOULD CONTAIN THIS INFORMATION ON THE FACE OF THE ENVELOPE OR THE BID MAY NOT BE CONSIDERED: SEALED BID						
BUYER:		ALAN CUMMINGS - FILE 33				
RFQ. NO.:		061200262				
BID OPENING DATE:		04/25/2012				
BID OPENING TIME:		1:30 P.M.				
PLEASE PROVIDE A FAX NUMBER IN CASE IT IS NECESSARY TO CONTACT YOU REGARDING YOUR BID: -----						
CONTACT PERSON (PLEASE PRINT CLEARLY): -----						
ANY INDIVIDUAL SIGNING THIS BID IS CERTIFYING THAT:						

SEE REVERSE SIDE FOR TERMS AND CONDITIONS

SIGNATURE	TELEPHONE	DATE
TITLE	FEIN	ADDRESS CHANGES TO BE NOTED ABOVE

WHEN RESPONDING TO RFQ, INSERT NAME AND ADDRESS IN SPACE ABOVE LABELED 'VENDOR'



State of West Virginia
 Department of Administration
 Purchasing Division
 2019 Washington Street East
 Post Office Box 50130
 Charleston, WV 25305-0130

Request for Quotation

RFQ NUMBER
061200262

PAGE
3

ADDRESS CORRESPONDENCE TO ATTENTION OF
ALAN CUMMINGS
304-558-2402

VENDOR

RFQ COPY
 TYPE NAME/ADDRESS HERE

SHIP TO

DIVISION OF HIGHWAYS
 DISTRICT SIX
 1 DOT DRIVE
 MOUNDSVILLE, WV
 26041 304-843-3656

DATE PRINTED	TERMS OF SALE	SHIP VIA	F.O.B.	FREIGHT TERMS
04/10/2012				

BID OPENING DATE: **04/25/2012** BID OPENING TIME **01:30PM**

LINE	QUANTITY	UOP	CAT NO	ITEM NUMBER	UNIT PRICE	AMOUNT
(1) HE OR SHE IS AUTHORIZED BY THE BIDDER TO EXECUTE THE BID OR ANY DOCUMENTS RELATED THERETO ON BEHALF OF THE BIDDER, (2) THAT HE OR SHE IS AUTHORIZED TO BIND THE BIDDER IN A CONTRACTUAL RELATIONSHIP, AND (3) THAT THE BIDDER HAS PROPERLY REGISTERED WITH ANY STATE AGENCIES THAT MAY REQUIRE REGISTRATION.						
***** THIS IS THE END OF RFQ 061200262 ***** TOTAL: _____						

SEE REVERSE SIDE FOR TERMS AND CONDITIONS

SIGNATURE		TELEPHONE	DATE
TITLE	FEIN	ADDRESS CHANGES TO BE NOTED ABOVE	

WHEN RESPONDING TO RFQ, INSERT NAME AND ADDRESS IN SPACE ABOVE LABELED 'VENDOR'

RFQ#: 061200262**Specifications**

Purpose: To replace aluminum bridge railing on the Benwood Bridge caused by three (3) accidents.

1.0 DEFINITIONS

- A. The "Agency" shall be defined as the West Virginia Division of Highways
- B. The "Vendor" shall be defined as the successful bidder.
- C. The "Purchase Order" shall be defined as the binding agreement that is entered into between the State of West Virginia and the Vendor to provide the services as herein specified.
- D. "Mandatory Requirements: The terms "must", "will", "shall", "minimum", "maximum", or "is/are required" identify a mandatory item or factor. Decisions regarding compliance with any mandatory requirements shall be at the sole discretion of the State.

2.0 SCOPE OF WORK

The successful Vendor shall provide materials for the railing on the Benwood Bridge caused by three (3) accidents.

- 2.1 Technical Requirements: Medal thickness (gauge) 5/16"
Post size: diameter and height—wf 6" x 6" x 5.5 alum 2' x 1 1/2"
Aluminum shall be in accordance with ASTM B 221 alloy 6061-T6 OR 6062-T6.
 - 2.1.1 Claim Number—CR1889R
 - Top Rail-3-1/8" x 4" Rectangular, Aluminum
 - Bottom Rail-3-3/4" x 4-3/4" Rectangular, Aluminum
 - a. Top Rail-straight: 8' 7" welded end caps on both ends
 - b. Bottom Rail-straight: 8' 7" welded end caps on both ends
 - c. Top Rail-straight: 10' welded end cap on one end
 - d. Aluminum clamp bars for top rail, hardware included
 - e. Aluminum camp bars for bottom rail, hardware included
 - f. Fabricated Aluminum Posts
 - g. Aluminum Spice sleeves for top rail

2.1.2 Claim Number- Cm1771R

- a. Top Rail 5' radius: 12' welded end cap on one end
- b. Bottom Rail 5' radius: 12' welded end cap on one end
- c. Aluminum splice sleeve for top rail
- d. Aluminum splice sleeve for bottom rail
- e. Aluminum Clamp Bars for Top Rail hardware included
- d. Aluminum Clamp Bars for Bottom Rail hardware included
- g. Fabricated Aluminum Post

2.1.3 Claim Number-B26A080

- a. Top Rail 5' radius: 9' weld end caps on both ends
- b. Aluminum clamp bars for top rail, hardware included
- c. Aluminum clamp bars for bottom rail, hardware included
- d. Fabricated Aluminum Post

2.1.4 Notes

- a. All Aluminum is Mill Finished
- b. Pricing is only valid for lump sum shipment of all three (3) accident claims

2.2 Freight: will be FOB destination

2.3 Delivery shall be made to the WVDOT:
West Virginia Division of Highways
1 Dot Drive Building 3
Moundsville, WV 26041
Attn: Dave Sada

3.0 INVOICING

3.1 Payment

3.1 The Vendor must send an invoice to:
West Virginia Division of Highways
1 Dot Drive Building 3
Moundsville, WV 26041
Attention: Harold Logsdon

3.2 Invoices will be paid with State Visa Card

4.0 AWARD

Purchase Order will be awarded to the lowest responsible bidder meeting the specifications listed. Purchase Order will be awarded complete and not split.

709.12-STRUCTURAL AND EYEBAR STEEL:

All structural steel for bridges shall conform to the applicable grade of AASHTO M270 that is specified in the Plans. When no specific grade for, AASHTO M270, Grade 36 shall be used. Non-designated structural steel in all other section of the Specifications shall conform to ASTM A36.

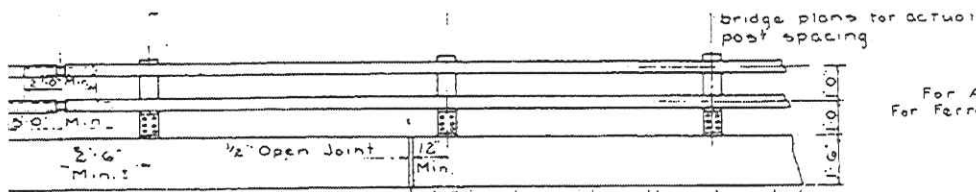

um Posts Shown
ALUMINUM & FERROUS METAL BRIDGE RAILING
 Scale: 3/8" = 1'-0"

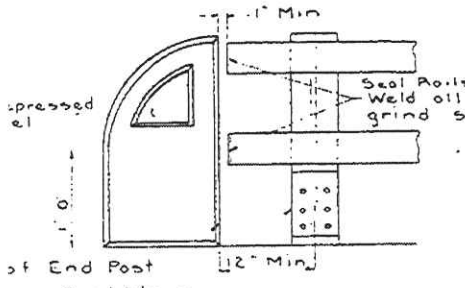
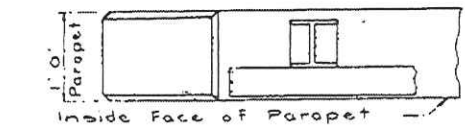

um Post Shown
TERMINATION OF RAILING DETAILS
 Scale: 1" = 1'-0"

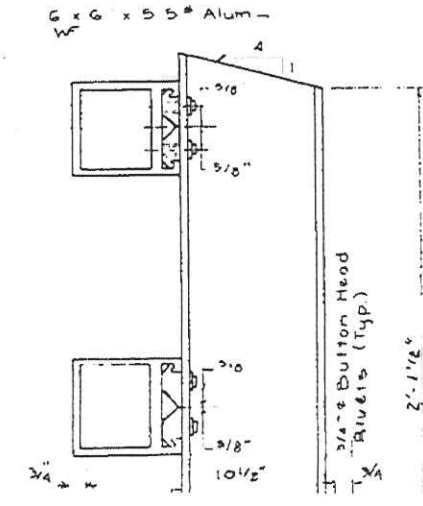

1/2" joint in sidewalk and curb to horizontal construction joint. Fill with preformed filler include cost in item 711

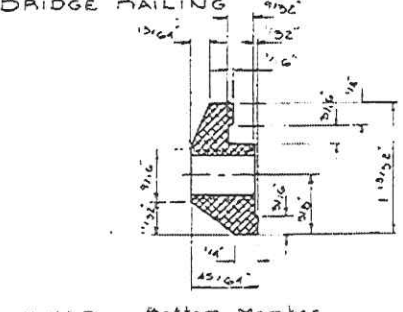

3 1/2" x 3 1/2" x 3/16" Sq Hollow Structural Tubing for Splice Sleeve Fit inside Rail (Ferrous Metal) Drill & Tap back side of Rail for 1/2" set screw
 1/2" @ Splice Joint (4 Exp. Joint same as slab opening)

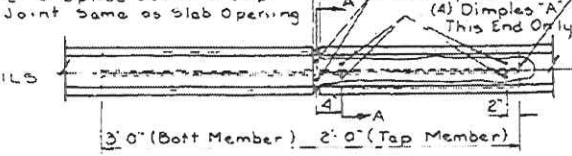

SPLICE DETAIL
 Scale: 1/2" = 1'-0"

Note - Aluminum Railing
 Posts, rails and base plates shall be extruded shapes as detailed, in accordance with ASTM B 221, alloy 6061-T6 or 6062-T6.
 All rivets and set screws shall be ASTM B-221 or B-211 alloy 6061 T6 temper weld filler wire shall be ASTM B-203, alloy ER-5356.
 Anchor bolts, washer, nuts and assembly shall be of same material and finish as ferrous metal.
 End closure for rails shall be a 1/4" plate fitted to the inside of the tubing, welded all around with an 1/8" weld and ground smooth.
 Rails on curved sections shall be bent to the correct radius in the shop.
 Anchor bolts to be cast in place.
 Posts shall be set normal to grade unless otherwise noted on the plans.
 Cost of anchor bolts, railing, rail posts, hardware, and elastomeric pads shall be included in the price bid for item 754 Aluminum Railing, per linear foot.
 No painting of posts and railing is required.
 All sharp edges shall be rounded.

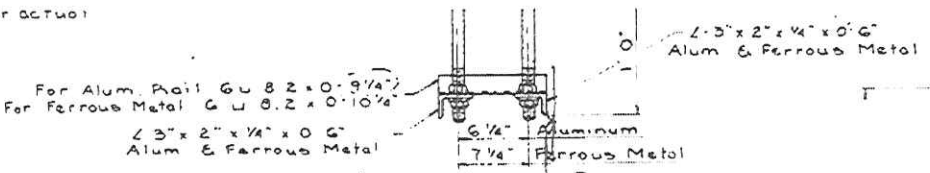

TYPICAL ANCHOR BOLT ASSEMBLY DETAIL
 Scale: 1/2" = 1'-0"

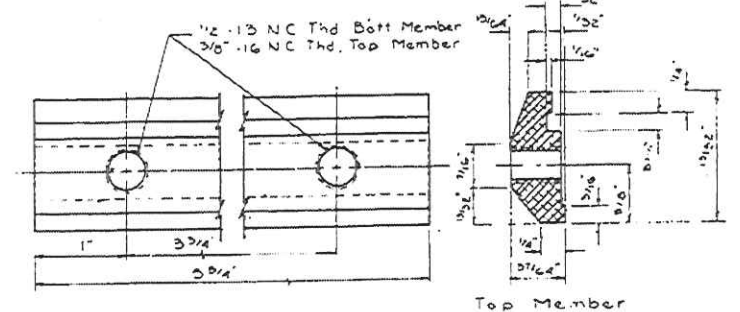

CLAMP BAR DETAILS

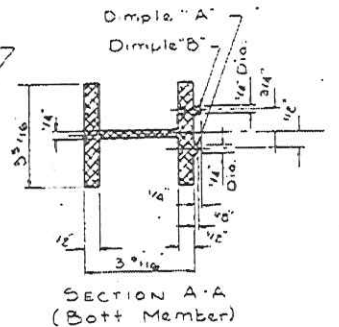

SECTION A-A (Bottom Member)

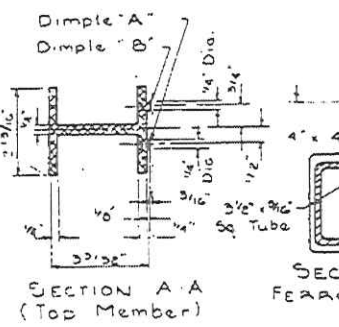

SECTION A-A (Top Member)

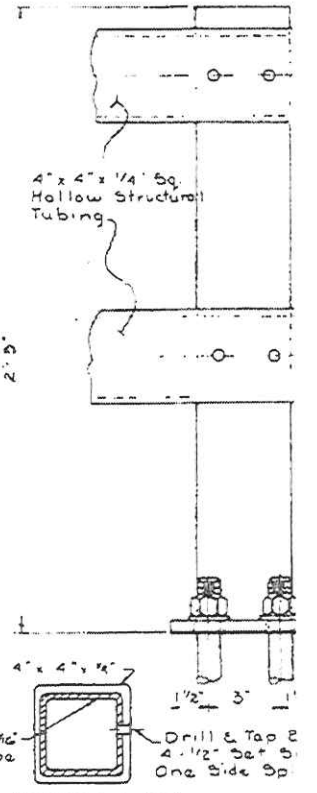

SECTION A-A FERROUS METAL

Art 51714 - Elastomeric Bearing Pads for Bridge Railing Posts:
 (A) General: These specifications cover an elastomeric bearing pad used for bridge railing posts. The thickness shall be as designated on plans. It shall be cast in molds under pressure and heat. The samples for test shall be prepared according to ASTM Tentative Method D-15. The pad shall meet the following requirements:
 (B) Physical Requirements:
 (1) Tensile Strength ASTM D412 (psi) 2500+
 (2) Durometer hardness ASTM D676 70 ± 5
 (3) Compression set ASTM D395 (22 hrs @ 158°F) (Percent) 25-
 (4) Change in Durometer hardness, heat aged 70 hrs @ 212°F 15-

Note -
 Al
 assemb
 Al
 nuts ar
 A.
 A.
 with or
 to be N
 for each
 Al
 drilling
 zinc coc
 Mill 60
 A
 to be galv
 Al
 galvaniz
 Pr
 Er
 inside o
 ground
 Pr
 correct
 A
 P.
 wise no
 C.
 and ela
 bid for
 N
 L
 F



Cost Sheet

Item Number	ESTIMATED QUANTITY	UNIT OF MEASURE	Description	Unit Price	EXTENDED Amount
1	1	EACH	TOP RAIL 3 1/8" X 4" RECTANGULAR ALUMINUM		\$
2	1	EACH	BOTTOM RAIL 3 3/4" X 4 3/4" RECTANGULAR ALUMINUM		\$
3	1	EACH	TOP RAIL STRIAGHT 8'-7" WELDED END CAPS ON BOTH ENDS		\$
4	1	EACH	BOTTOM RAIL STRAIGHT 8'-7" WELDED END CAPS ON BOTH ENDS		\$
5	1	EACH	TOP RAIL STRAIGHT 10'-0" WELDED END CAP ON ONE END		\$
6	1	EACH	TOP RAIL 5' RADIOUS: 12'-0" WELDED END CAP ON ONE END		\$
7	1	EACH	BOTTOM RAIL 5' RADIOUS: 9'-0" WELDED END CAPS ON ONE END		\$
8	1	EACH	TOP RAIL 5' RADIOUS: 9'-0" WELDED END CAPS ON BOTH ENDS		\$
9	16	EACH	ALUMINUM CLAMP BARS FOR TOP RAIL, HARDWARE INCLUDED		\$
10	14	EACH	ALUMINUM CLAMP BARS FOR BOTTOM RAIL, HARDWARE INCLUDED		\$
11	5	EACH	FABRICATED ALUMINUM POSTS		\$
12	3	EACH	ALUMINUM SPLICE SLEEVES FOR TOP RAIL		\$
13	1	EACH	ALUMINUM SPLICE SLEEVES FOR BOTTOM RAIL		\$
			ALL ALUMINUM IS MILL FINISH		
			TOTAL COST		\$

State of West Virginia

VENDOR PREFERENCE CERTIFICATE

Certification and application* is hereby made for Preference in accordance with *West Virginia Code*, §5A-3-37. (Does not apply to construction contracts). *West Virginia Code*, §5A-3-37, provides an opportunity for qualifying vendors to request (at the time of bid) preference for their residency status. Such preference is an evaluation method only and will be applied only to the cost bid in accordance with the *West Virginia Code*. This certificate for application is to be used to request such preference. The Purchasing Division will make the determination of the Resident Vendor Preference, if applicable.

- 1. **Application is made for 2.5% resident vendor preference for the reason checked:**
 Bidder is an individual resident vendor and has resided continuously in West Virginia for four (4) years immediately preceding the date of this certification; **or**,
 Bidder is a partnership, association or corporation resident vendor and has maintained its headquarters or principal place of business continuously in West Virginia for four (4) years immediately preceding the date of this certification; or 80% of the ownership interest of Bidder is held by another individual, partnership, association or corporation resident vendor who has maintained its headquarters or principal place of business continuously in West Virginia for four (4) years immediately preceding the date of this certification; **or**,
 Bidder is a nonresident vendor which has an affiliate or subsidiary which employs a minimum of one hundred state residents and which has maintained its headquarters or principal place of business within West Virginia continuously for the four (4) years immediately preceding the date of this certification; **or**,
- 2. **Application is made for 2.5% resident vendor preference for the reason checked:**
 Bidder is a resident vendor who certifies that, during the life of the contract, on average at least 75% of the employees working on the project being bid are residents of West Virginia who have resided in the state continuously for the two years immediately preceding submission of this bid; **or**,
- 3. **Application is made for 2.5% resident vendor preference for the reason checked:**
 Bidder is a nonresident vendor employing a minimum of one hundred state residents or is a nonresident vendor with an affiliate or subsidiary which maintains its headquarters or principal place of business within West Virginia employing a minimum of one hundred state residents who certifies that, during the life of the contract, on average at least 75% of the employees or Bidder's affiliate's or subsidiary's employees are residents of West Virginia who have resided in the state continuously for the two years immediately preceding submission of this bid; **or**,
- 4. **Application is made for 5% resident vendor preference for the reason checked:**
 Bidder meets either the requirement of both subdivisions (1) and (2) or subdivision (1) and (3) as stated above; **or**,
- 5. **Application is made for 3.5% resident vendor preference who is a veteran for the reason checked:**
 Bidder is an individual resident vendor who is a veteran of the United States armed forces, the reserves or the National Guard and has resided in West Virginia continuously for the four years immediately preceding the date on which the bid is submitted; **or**,
- 6. **Application is made for 3.5% resident vendor preference who is a veteran for the reason checked:**
 Bidder is a resident vendor who is a veteran of the United States armed forces, the reserves or the National Guard, if, for purposes of producing or distributing the commodities or completing the project which is the subject of the vendor's bid and continuously over the entire term of the project, on average at least seventy-five percent of the vendor's employees are residents of West Virginia who have resided in the state continuously for the two immediately preceding years.

Bidder understands if the Secretary of Revenue determines that a Bidder receiving preference has failed to continue to meet the requirements for such preference, the Secretary may order the Director of Purchasing to: (a) reject the bid; or (b) assess a penalty against such Bidder in an amount not to exceed 5% of the bid amount and that such penalty will be paid to the contracting agency or deducted from any unpaid balance on the contract or purchase order.

By submission of this certificate, Bidder agrees to disclose any reasonably requested information to the Purchasing Division and authorizes the Department of Revenue to disclose to the Director of Purchasing appropriate information verifying that Bidder has paid the required business taxes, provided that such information does not contain the amounts of taxes paid nor any other information deemed by the Tax Commissioner to be confidential.

Under penalty of law for false swearing (West Virginia Code, §61-5-3), Bidder hereby certifies that this certificate is true and accurate in all respects; and that if a contract is issued to Bidder and if anything contained within this certificate changes during the term of the contract, Bidder will notify the Purchasing Division in writing immediately.

Bidder: _____ Signed: _____

Date: _____ Title: _____

*Check any combination of preference consideration(s) indicated above, which you are entitled to receive.

STATE OF WEST VIRGINIA
Purchasing Division

PURCHASING AFFIDAVIT

West Virginia Code §5A-3-10a states: No contract or renewal of any contract may be awarded by the state or any of its political subdivisions to any vendor or prospective vendor when the vendor or prospective vendor or a related party to the vendor or prospective vendor is a debtor and the debt owed is an amount greater than one thousand dollars in the aggregate.

DEFINITIONS:

"Debt" means any assessment, premium, penalty, fine, tax or other amount of money owed to the state or any of its political subdivisions because of a judgment, fine, permit violation, license assessment, defaulted workers' compensation premium, penalty or other assessment presently delinquent or due and required to be paid to the state or any of its political subdivisions, including any interest or additional penalties accrued thereon.

"Debtor" means any individual, corporation, partnership, association, limited liability company or any other form or business association owing a debt to the state or any of its political subdivisions. "Political subdivision" means any county commission; municipality; county board of education; any instrumentality established by a county or municipality; any separate corporation or instrumentality established by one or more counties or municipalities, as permitted by law; or any public body charged by law with the performance of a government function or whose jurisdiction is coextensive with one or more counties or municipalities. "Related party" means a party, whether an individual, corporation, partnership, association, limited liability company or any other form or business association or other entity whatsoever, related to any vendor by blood, marriage, ownership or contract through which the party has a relationship of ownership or other interest with the vendor so that the party will actually or by effect receive or control a portion of the benefit, profit or other consideration from performance of a vendor contract with the party receiving an amount that meets or exceed five percent of the total contract amount.

EXCEPTION: The prohibition of this section does not apply where a vendor has contested any tax administered pursuant to chapter eleven of this code, workers' compensation premium, permit fee or environmental fee or assessment and the matter has not become final or where the vendor has entered into a payment plan or agreement and the vendor is not in default of any of the provisions of such plan or agreement.

Under penalty of law for false swearing (*West Virginia Code §61-5-3*), it is hereby certified that the vendor affirms and acknowledges the information in this affidavit and is in compliance with the requirements as stated.

WITNESS THE FOLLOWING SIGNATURE

Vendor's Name: _____

Authorized Signature: _____ Date: _____

State of _____

County of _____, to-wit:

Taken, subscribed, and sworn to before me this ____ day of _____, 20__.

My Commission expires _____, 20__.

AFFIX SEAL HERE

NOTARY PUBLIC _____

Please use this document for technical questions, posing in a question format

Please refer to the section your question is in reference to.

Technical questions for RFQ# _____

Vendor Name: _____

Questions:
