



State of West Virginia
 Department of Administration
 Purchasing Division
 2019 Washington Street East
 Post Office Box 50130
 Charleston, WV 25305-0130

Request for Quotation

RFQ NUMBER
02120430

PAGE
1

ADDRESS CORRESPONDENCE TO ATTENTION OF:
ALAN CUMMINGS
304-558-2402

RFQ COPY

TYPE NAME/ADDRESS HERE

VENDOR

SHIP TO

DIVISION OF HIGHWAYS
 JOBSITE
 SEE SPECIFICATIONS

DATE PRINTED	TERMS OF SALE	SHIP VIA	F.O.B.	FREIGHT TERMS
04/11/2012				

BID OPENING DATE: 04/25/2012 BID OPENING TIME 01:30PM

LINE	QUANTITY	UOP	CAT. NO.	ITEM NUMBER	UNIT PRICE	AMOUNT
0001		LS		210-16		
PRESTRESSED BOX BEAMS THE WEST VIRGINIA STATE PURCHASING DIVISION FOR THE AGENCY, THE WEST VIRGINIA DIVISION OF HIGHWAYS, IS SOLICITING BIDS TO PROVIDE THE AGENCY WITH PRESTRESSED CONCRETE BEAMS AND ACCESSORIES PER THE ATTACHED SPECIFICATIONS. LENGTH: 41'-6" (OUT TO OUT) WIDTH: 21'-4 1/2" (OUT TO OUT, INCLUDES 3/4" BETWEEN BEAMS) SKEW: 20 DEGREES LFS DESIGN TO BE IN ACCORDANCE WITH SECTION 603 OF THE CURRENT WVDOT STANDARDS AND SPECIFICATIONS DELIVERY DATE: SEPTEMBER, 2012 BANKRUPTCY: IN THE EVENT THE VENDOR/CONTRACTOR FILES FOR BANKRUPTCY PROTECTION, THE STATE MAY DEEM THE CONTRACT NULL AND VOID, AND TERMINATE SUCH CONTRACT WITHOUT FURTHER ORDER. CANCELLATION: THE DIRECTOR OF PURCHASING RESERVES THE RIGHT TO CANCEL THIS CONTRACT IMMEDIATELY UPON WRITTEN NOTICE TO THE VENDOR IF THE COMMODITIES AND/OR SERVICES SUPPLIED ARE OF AN INFERIOR QUALITY OR DO NOT CONFORM TO THE SPECIFICATIONS OF THE BID AND CONTRACT HEREIN. PREFERENCE FOR USE OF DOMESTIC STEEL PRODUCTS						

SEE REVERSE SIDE FOR TERMS AND CONDITIONS

SIGNATURE	TELEPHONE	DATE
TITLE	FEIN	ADDRESS CHANGES TO BE NOTED ABOVE

WHEN RESPONDING TO RFQ, INSERT NAME AND ADDRESS IN SPACE ABOVE LABELED 'VENDOR'

GENERAL TERMS & CONDITIONS REQUEST FOR QUOTATION (RFQ) AND REQUEST FOR PROPOSAL (RFP)

1. Awards will be made in the best interest of the State of West Virginia.
2. The State may accept or reject in part, or in whole, any bid.
3. Prior to any award, the apparent successful vendor must be properly registered with the Purchasing Division and have paid the required \$125 fee.
4. All services performed or goods delivered under State Purchase Order/Contracts are to be continued for the term of the Purchase Order/Contracts, contingent upon funds being appropriated by the Legislature or otherwise being made available. In the event funds are not appropriated or otherwise available for these services or goods this Purchase Order/Contract becomes void and of no effect after June 30.
5. Payment may only be made after the delivery and acceptance of goods or services.
6. Interest may be paid for late payment in accordance with the *West Virginia Code*.
7. Vendor preference will be granted upon written request in accordance with the *West Virginia Code*.
8. The State of West Virginia is exempt from federal and state taxes and will not pay or reimburse such taxes.
9. The Director of Purchasing may cancel any Purchase Order/Contract upon 30 days written notice to the seller.
10. The laws of the State of West Virginia and the *Legislative Rules* of the Purchasing Division shall govern the purchasing process.
11. Any reference to automatic renewal is hereby deleted. The Contract may be renewed only upon mutual written agreement of the parties.
12. **BANKRUPTCY:** In the event the vendor/contractor files for bankruptcy protection, the State may deem this contract null and void, and terminate such contract without further order.
13. **HIPAA BUSINESS ASSOCIATE ADDENDUM:** The West Virginia State Government HIPAA Business Associate Addendum (BAA), approved by the Attorney General, is available online at www.state.wv.us/admin/purchase/vrc/hipaa.html and is hereby made part of the agreement provided that the Agency meets the definition of a Cover Entity (45 CFR §160.103) and will be disclosing Protected Health Information (45 CFR §160.103) to the vendor.
14. **CONFIDENTIALITY:** The vendor agrees that he or she will not disclose to anyone, directly or indirectly, any such personally identifiable information or other confidential information gained from the agency, unless the individual who is the subject of the information consents to the disclosure in writing or the disclosure is made pursuant to the agency's policies, procedures, and rules. Vendor further agrees to comply with the Confidentiality Policies and Information Security Accountability Requirements, set forth in <http://www.state.wv.us/admin/purchase/privacy/noticeConfidentiality.pdf>.
15. **LICENSING:** Vendors must be licensed and in good standing in accordance with any and all state and local laws and requirements by any state or local agency of West Virginia, including, but not limited to, the West Virginia Secretary of State's Office, the West Virginia Tax Department, and the West Virginia Insurance Commission. The vendor must provide all necessary releases to obtain information to enable the director or spending unit to verify that the vendor is licensed and in good standing with the above entities.
16. **ANTITRUST:** In submitting a bid to any agency for the State of West Virginia, the bidder offers and agrees that if the bid is accepted the bidder will convey, sell, assign or transfer to the State of West Virginia all rights, title and interest in and to all causes of action it may now or hereafter acquire under the antitrust laws of the United States and the State of West Virginia for price fixing and/or unreasonable restraints of trade relating to the particular commodities or services purchased or acquired by the State of West Virginia. Such assignment shall be made and become effective at the time the purchasing agency tenders the initial payment to the bidder.

I certify that this bid is made without prior understanding, agreement, or connection with any corporation, firm, limited liability company, partnership, or person or entity submitting a bid for the same material, supplies, equipment or services and is in all respects fair and without collusion or Fraud. I further certify that I am authorized to sign the certification on behalf of the bidder or this bid.

INSTRUCTIONS TO BIDDERS

1. Use the quotation forms provided by the Purchasing Division. Complete all sections of the quotation form.
2. Items offered must be in compliance with the specifications. Any deviation from the specifications must be clearly indicated by the bidder. Alternates offered by the bidder as **EQUAL** to the specifications must be clearly defined. A bidder offering an alternate should attach complete specifications and literature to the bid. The Purchasing Division may waive minor deviations to specifications.
3. Unit prices shall prevail in case of discrepancy. All quotations are considered F.O.B. destination unless alternate shipping terms are clearly identified in the quotation.
4. All quotations must be delivered by the bidder to the office listed below prior to the date and time of the bid opening. Failure of the bidder to deliver the quotations on time will result in bid disqualifications: Department of Administration, Purchasing Division, 2019 Washington Street East, P.O. Box 50130, Charleston, WV 25305-0130
5. Communication during the solicitation, bid, evaluation or award periods, except through the Purchasing Division, is strictly prohibited (W.Va. C.S.R. §148-1-6.6).



State of West Virginia
 Department of Administration
 Purchasing Division
 2019 Washington Street East
 Post Office Box 50130
 Charleston, WV 25305-0130

Request for Quotation

RFQ NUMBER
 02120430

PAGE
 2

ADDRESS CORRESPONDENCE TO ATTENTION OF
 ALAN CUMMINGS
 304-558-2402

RFQ COPY

TYPE NAME/ADDRESS HERE

VENDOR

SHIP TO

DIVISION OF HIGHWAYS
 JOBSITE
 SEE SPECIFICATIONS

DATE PRINTED	TERMS OF SALE	SHIP VIA	F.O.B.	FREIGHT TERMS
04/11/2012				
BID OPENING DATE: 04/25/2012		BID OPENING TIME 01:30PM		

LINE	QUANTITY	UOP	CAT NO	ITEM NUMBER	UNIT PRICE	AMOUNT
1.				EXCEPT WHEN AUTHORIZED BY THE DIRECTOR OF THE PURCHASING DIVISION PURSUANT TO SUBSECTION 2 BELOW, NO CONTRACTOR MAY USE OR SUPPLY STEEL PRODUCTS FOR A STATE CONTRACT PROJECT OTHER THAN THOSE STEEL PRODUCTS MADE IN THE UNITED STATES. AS USED USED IN THIS CONTRACT,		
				A. "STATE CONTRACT PROJECT" MEANS ANY ERECTION OR CONSTRUCTION OF, OR ANY ADDITION TO, ALTERATION OF OR OTHER IMPROVEMENT TO ANY BUILDING OR STRUCTURE, INCLUDING, BUT NOT LIMITED TO, ROADS OR HIGHWAYS, OR THE INSTALLATION OF ANY HEATIN OR COOLING OR VENTILATING PLANTS OR OTHER EQUIPMENT, OR THE SUPPLY OF AND MATERIALS FOR SUCH PROJECTS, PURSUANT TO A CONTRACT WITH THE STATE OF WEST VIRGINIA FOR WHICH BIDS WERE SOLICITED ON OR AFTER JUNE 6, 2001.		
				B. "STEEL PRODUCTS" MEANS PRODUCTS ROLLED, FORMED, SHAPED, DRAWN, EXTRUDED, FORGED, CAST, FABRICATED OR OTHERWISE SIMILARLY PROCESSED, OR PROCESSED BY A COMBINATION OF TWO OR MORE OF SUCH OPERATIONS. FROM STEEL MADE BY THE OPEN HEARTH, BASIC OXYGEN, ELECTRIC FURNACE, BESSEMER OR OTHER STEEL MAKING PROCESS.		
				C. "UNITED STATES" MEANS THE UNITED STATES OF AMERICA AND INCLUDES ALL TERRITORY, CONTINENTAL OR INSULAR, SUBJECT TO THE JURISDICTION OF THE UNITED STATES.		
2.				THE DIRECTOR OF THE PURCHASING DIVISION MAY, IN WRITING, AUTHORIZE THE USE OF FOREIGN STEEL PRODUCTS IF:		
				A. THE COST FOR EACH CONTRACT ITEM USED DOES NOT		

SEE REVERSE SIDE FOR TERMS AND CONDITIONS

SIGNATURE	TELEPHONE	DATE
TITLE	FEIN	ADDRESS CHANGES TO BE NOTED ABOVE

WHEN RESPONDING TO RFQ, INSERT NAME AND ADDRESS IN SPACE ABOVE LABELED 'VENDOR'



State of West Virginia
 Department of Administration
 Purchasing Division
 2019 Washington Street East
 Post Office Box 50130
 Charleston, WV 25305-0130

Request for Quotation

RFQ NUMBER
02120430

PAGE
3

ADDRESS CORRESPONDENCE TO ATTENTION OF
ALAN CUMMINGS 304-558-2402

RFQ COPY

TYPE NAME/ADDRESS HERE

VENDOR

DIVISION OF HIGHWAYS
 JOBSITE
 SEE SPECIFICATIONS

SHIP TO

DATE PRINTED	TERMS OF SALE	SHIP VIA	F.O.B.	FREIGHT TERMS
04/11/2012				

BID OPENING DATE: 04/25/2012 BID OPENING TIME 01:30PM

LINE	QUANTITY	UOP	CAT NO.	ITEM NUMBER	UNIT PRICE	AMOUNT
				EXCEED ONE TENTH OF ONE PERCENT (.1%) OF THE TOTAL CONTRACT COST OR TWO THOUSAND FIVE HUNDRED DOLLARS (2,500.00), WHICHEVER IS GREATER. FOR THE PURPOSES OF THIS SECTION, THE COST IS THE VALUE OF THE STEEL PRODUCT AS DELIVERED TO THE PROJECT OR,		
				B. THE DIRECTOR OF THE PURCHASING DIVISION DETERMINES THAT SPECIFIED STEEL MATERIALS ARE NOT PRODUCED IN THE UNITED STATES IN SUFFICIENT QUANTITY OR OTHERWISE ARE NOT REASONABLY AVAILABLE TO MEET CONTRACT REQUIREMENTS.		
3				A CONTRACTOR WHO USES STEEL PRODUCTS IN VIOLATION OF THIS SECTION MAY BE SUBJECT TO CIVIL PENALTIES PURSUANT TO WV CODE SECTION 5A-3-56.		
				REV. 10/01/01		
				NOTICE		
				A SIGNED BID MUST BE SUBMITTED TO:		
				DEPARTMENT OF ADMINISTRATION PURCHASING DIVISION BUILDING 15 2019 WASHINGTON STREET, EAST CHARLESTON, WV 25305-0130		
				THE BID SHOULD CONTAIN THIS INFORMATION ON THE FACE OF THE ENVELOPE OR THE BID MAY NOT BE CONSIDERED:		

SEE REVERSE SIDE FOR TERMS AND CONDITIONS

SIGNATURE	TELEPHONE	DATE
TITLE	FEIN	ADDRESS CHANGES TO BE NOTED ABOVE

WHEN RESPONDING TO RFQ, INSERT NAME AND ADDRESS IN SPACE ABOVE LABELED 'VENDOR'



State of West Virginia
 Department of Administration
 Purchasing Division
 2019 Washington Street East
 Post Office Box 50130
 Charleston, WV 25305-0130

Request for Quotation

RFQ NUMBER
02120430

PAGE
4

ADDRESS CORRESPONDENCE TO ATTENTION OF
ALAN CUMMINGS 304-558-2402

RFQ COPY

TYPE NAME/ADDRESS HERE

VENDOR

DIVISION OF HIGHWAYS
 JOBSITE
 SEE SPECIFICATIONS

SHIP TO

DATE PRINTED	TERMS OF SALE	SHIP VIA	F.O.B.	FREIGHT TERMS
04/11/2012				

BID OPENING DATE: 04/25/2012 BID OPENING TIME 01:30PM

LINE	QUANTITY	UOP	CAT NO.	ITEM NUMBER	UNIT PRICE	AMOUNT
SEALED BID						
BUYER:			ALAN CUMMINGS - FILE 33			
RFQ. NO.:			02120430			
BID OPENING DATE:			04/25/2012			
BID OPENING TIME:			1:30 P.M.			
PLEASE PROVIDE A FAX NUMBER IN CASE IT IS NECESSARY TO CONTACT YOU REGARDING YOUR BID:						

CONTACT PERSON (PLEASE PRINT CLEARLY):						

ANY INDIVIDUAL SIGNING THIS BID IS CERTIFYING THAT: (1) HE OR SHE IS AUTHORIZED BY THE BIDDER TO EXECUTE THE BID OR ANY DOCUMENTS RELATED THERETO ON BEHALF OF THE BIDDER, (2) THAT HE OR SHE IS AUTHORIZED TO BIND THE BIDDER IN A CONTRACTUAL RELATIONSHIP, AND (3) THAT THE BIDDER HAS PROPERLY REGISTERED WITH ANY STATE AGENCIES THAT MAY REQUIRE REGISTRATION.						

SEE REVERSE SIDE FOR TERMS AND CONDITIONS

SIGNATURE		TELEPHONE	DATE
TITLE	FEIN	ADDRESS CHANGES TO BE NOTED ABOVE	

WHEN RESPONDING TO RFQ, INSERT NAME AND ADDRESS IN SPACE ABOVE LABELED 'VENDOR'

Specifications One Time Purchase

Purpose: To provide the West Virginia Division of Highways with prestressed concrete beams and accessories to be used on Project # S350-36/2-3.62, Right Fork of Mill Creek Bridge.

1.0 DEFINITIONS

- A. The "Agency" shall be defined as the West Virginia Division of Highways.
- B. The "Vendor" shall be defined as the successful bidder.
- C. The "Purchase Order" shall be defined as the binding agreement that is entered into between the State of West Virginia and the Vendor to provide the services as herein specified.
- D. "Mandatory Requirements: The terms "must", "will", "shall", "minimum", "maximum", or "is/are required" identify a mandatory item or factor. Decisions regarding compliance with any mandatory requirements shall be at the sole discretion of the State.

2.0 SCOPE OF WORK

The successful Vendor shall provide 36" wide x 17" deep prestressed concrete beams with accessories.

2.1 Technical Requirements:

All prestressed concrete beams and accessories provided shall be in accordance with West Virginia Division of Highways Standard Specifications Roads and Bridges, adopted 2010 and the current Supplemental Specifications and the attached control prints.

www.transportation.wv.gov/highways/engineering/Pages/publications.aspx

2.2 Freight

2.2.1 All shipments are to be FOB Destination.

2.2.2 The Vendor shall be responsible for all costs associated with the delivery to the job site.

2.3 Delivery

2.3.1 Deliveries shall be made to job site on CR 36/2 (Map Attached)

2.3.2 Delivery is currently scheduled for September, 2012 Vendor shall coordinate delivery with the District Bridge Engineer @ 304-528-5655.

2.4 Delivery is an integral part of this purchase order and failure to comply will be cause to initiate a WV-82, vendor Performance Form. This form will officially notify the West Virginia Division of Purchasing and the Vendor of unsatisfactory performance in the execution of this purchase order and the requirements herein.

3.0 INVOICING

3.1 Payment

3.1.1 The Vendor must send an invoice to:
West Virginia Division of Highways, District Two
801 Madison Avenue
Huntington, WV 25704

3.2.1 Upon completion of manufacture and approval by the Division of Highways of all beams specified on the purchase order, the vendor may invoice and the Division of highways when all the Beams are delivered.

- a. The vendor shall furnish a statement of approved Beams' condition and exact storage location.
- b. The vendor shall furnish a legal right-of-entry onto the storage site to Division of Highways' employees and/or agents for the purpose of inspecting, sampling, testing, and removing any or all Beams.
- c. The vendor shall certify that the stored Beams are suitably marked and identified as property of the Division of

highways and will not be used for any purpose not designated by the Division.

4.0 AWARD

Purchase order will be awarded to the lowest responsible bidder meeting all mandatory specifications complete and not split.

Cost Sheet

Item Number	Quantity	Unit of Measure	Description	Unit Price	Extended	Amount
1	207.5	Linear Feet	Interior Beam 17" prestressed concrete box beam (3ft. Wide) 5 beams x 41.5			
2	83	Linear Feet	exterior Beam 17" prestressed concrete box beam (3ft. Wide) 2 beams x 41.5			
3	28	Each	Elastomeric Bearing Pads			
4	14	Each	1" Diameter x 2'-0" Anchor bolt or No. 8 deformed rebar			
5	14	Each	Guardrail Attachment Assembly for box beam w/ studs, nut and washers			
6	3	Each	1" Diameter Post- Tensioning Bar w/nuts			
7	14	Each	Bearing Plates			
8	1	Lump Sum	Thick sponge rubber Preformed joint filler			
9	91	Linear Feet	Guardrail			
				Total		

Items for Project S350-36/2-3.62, Right Fork of Mill Creek

RIGHT FORK OF MILL CREEK
S350-36/2-3.62 00

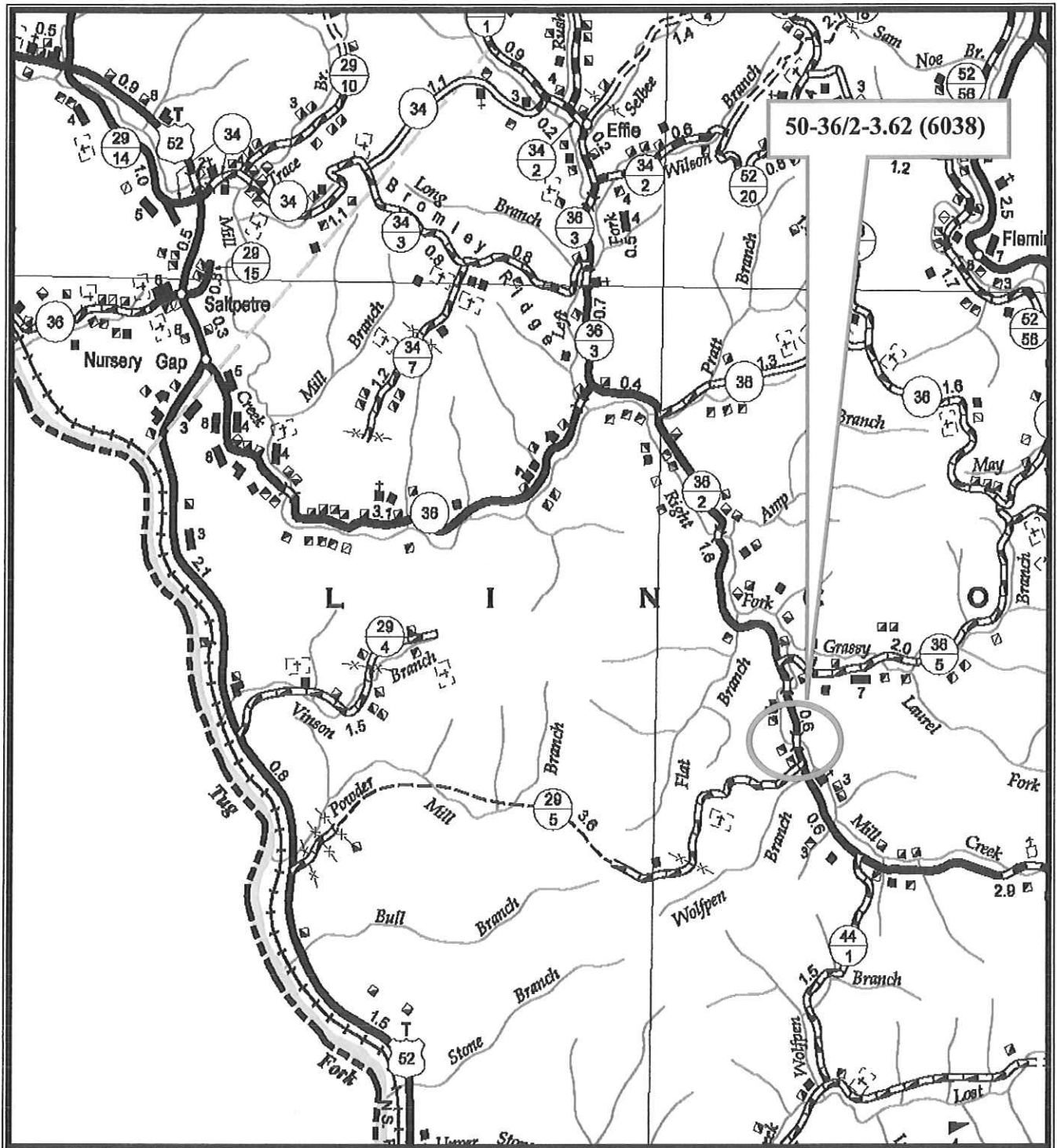

Org: 0298
Auth.: SD2562M

PROJECT NUMBERS		DISTRICT	COUNTY	SHEET NO.	TOTAL
S350-362-3.62	FEDERAL	02	WAYNE	1	10

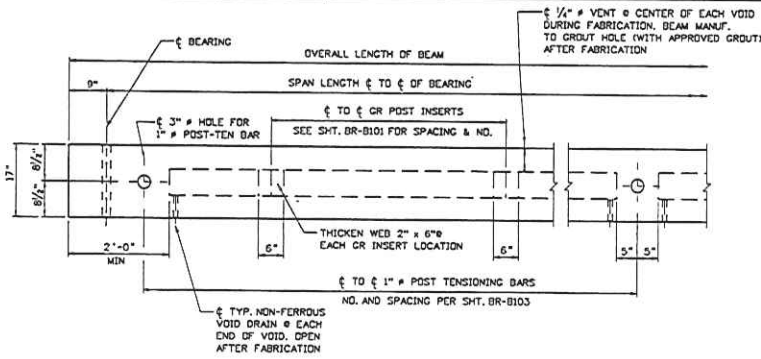

GENERAL ELEVATION VIEW

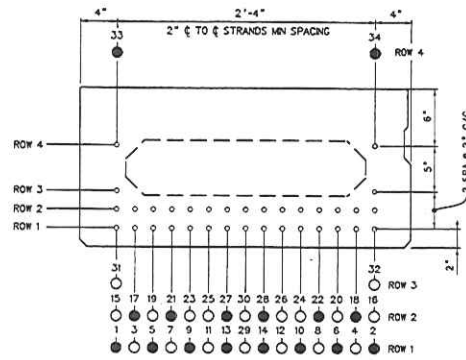

BEAM PRESTRESSING
TYPICAL @ BEAM END & MIDSPAN

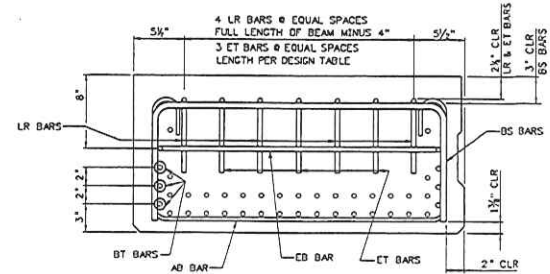

SECTION A-A

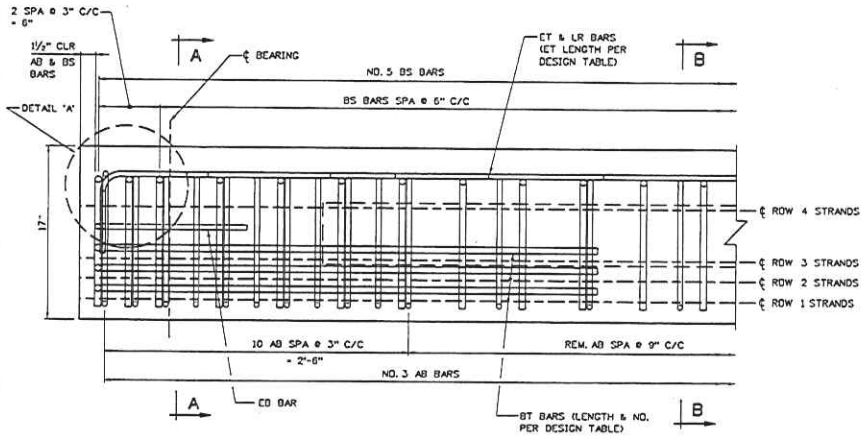

REINFORCING STEEL ELEVATION

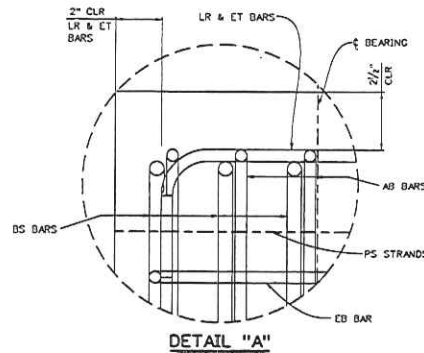

DETAIL "A"

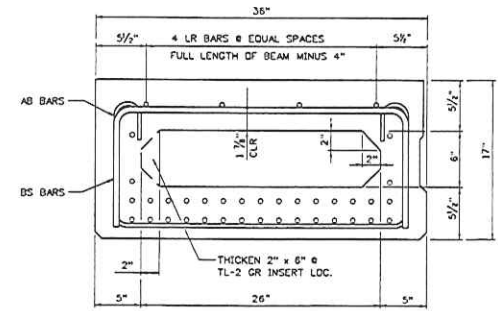

SECTION B-B

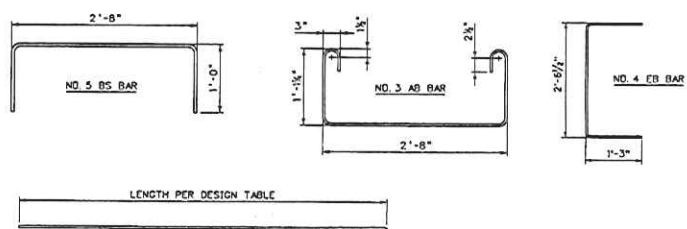

REINFORCING BAR DETAIL

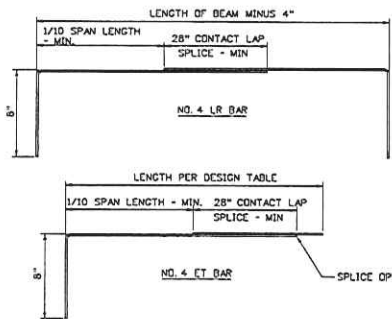

NOTES:

- REFER TO SHEET BR-B102A FOR SHEAR KEY DETAILS.
- DESIGNER SHALL USE THE FOLLOWING KEY TO INDICATE STRAND AND DEBOND PATTERN ON "BEAM PRESTRESSING VIEW", THIS SHEET.
 - ACTIVE STRAND
 - ▽ DEBOND STRAND: LENGTH FROM END OF BEAM
 - △ DEBOND STRAND: LENGTH FROM END OF BEAM
 - DEBOND STRAND: LENGTH FROM END OF BEAM
- THIS SHEET SHALL BE USED IN CONJUNCTION WITH STANDARD SHEETS BR-B176, BR-B180, BR-B181, BR-B182A & B, BR-B183, BR-B184, BR-B185A & B AND BR-B186 AS APPLICABLE.

WHEN A POST-TEN ACCESS POCKET IS USED AS DETAILED ON SHEET BR-B103 STRANDS IN ROWS 3 AND 4 SHALL BE CLIPMARKED. THE BEAM SHALL BE REDESIGNED AS NECESSARY.

APPROVED: *Gregory D. Barks* DATE: 10-25-07
DIRECTOR, ENGINEERING DIVISION

WEST VIRGINIA DEPARTMENT OF TRANSPORTATION
DIVISION OF HIGHWAYS
ENGINEERING DIVISION

17" PRESTRESSED CONCRETE
BOX BEAMS
DESIGN AND ASSEMBLY DETAILS

STANDARD SHEET BR-B17A

PREPARED: 07-02-07
REVISION:

WEST VIRGINIA DEPARTMENT OF TRANSPORTATION
DIVISION OF HIGHWAYS
ENGINEERING DIVISION

Right Fork of Mill Creek Bridge
over
Right Fork of Mill Creek

17" PRESTRESSED BOX BEAM
DESIGN AND ASSEMBLY DETAILS

DESIGNED BY:TW/
DRAWN BY:GN/
CHECKED BY:TW/
REVIEWED BY:TW/
DATE:
SCALE:
SHEET OF
BRIDGE NO.

DESIGN DATA FOR 17" DEPTH ADJACENT BOX BEAM

SPAN LENGTH ℓ TO ℓ BEARING	20'-0"	22'-0"	24'-0"	26'-0"	28'-0"	30'-0"	32'-0"	34'-0"	36'-0"	38'-0"	40'-0"						
OVERALL LENGTH OF BEAM	21'-6"	23'-6"	25'-6"	27'-6"	29'-6"	31'-6"	33'-6"	35'-6"	37'-6"	39'-6"	41'-6"						
NO. OF 270 KSI, 1/2" # LOW-RELAXATION STRANDS, AREA/STRAND = 0.167 SQ. IN.	10	10	10	10	12	12	14	14	16	16	16						
STRAND POSITION NUMBER	ROW 1	1,2,11,12	1,2,11,12	1,2,11,12	1,2,11,12	1,2,7,8,13,14	1,2,7,8,13,14	1,2,7,8,13,14	1,2,5,6,9,10,13,14	2,5,6,9,10,13,14	1,2,5,6,9,10,13,14						
	ROW 2	17,18,25,26	17,18,25,26	17,18,25,26	17,18,25,26	17,18,27,28	17,18,27,28	17,18,21,22,27,28	17,18,21,22,27,28	17,18,21,22,27,28	17,18,21,22,27,28						
	ROW 3	---	---	---	---	---	---	---	---	---	---						
	ROW 4	33,34	33,34	33,34	33,34	33,34	33,34	33,34	33,34	33,34	33,34						
PRESTRESSING FORCE IMMEDIATELY AFTER STRAND RELEASE, Ppl, (KIPS/BEAM)	326	326	326	326	389	389	451	451	512	512	513						
EFFECTIVE PRESTRESSING FORCE AFTER ALL LOSSES, Ppe, (KIPS/BEAM)	293	293	294	294	345	346	396	397	443	443	447						
REQUIRED FACTORED MOMENT M_u (FT-KIPS/BEAM)	204	231	260	289	319	349	382	415	453	491	531						
FACTORED FLEXURAL RESISTANCE, M_r (FT-KIPS/BEAM)	408	408	408	408	496	496	566	566	646	646	646						
TOTAL NO. DEBONDED STRANDS	---	---	---	---	---	---	---	---	---	---	---						
DEBONDED STRAND POSITION NUMBER & SHIELDING LENGTH FROM EACH END	ROW 1	---	---	---	---	---	---	---	---	---	---						
	ROW 2	---	---	---	---	---	---	---	---	---	---						
NUMBER & LENGTH #4 ET TOP TENSION BARS ϕ EACH END	3 - #4 x 3'-6"	3 - #4 x 3'-6"	3 - #4 x 4'-0"	3 - #4 x 4'-0"	3 - #4 x 4'-0"	3 - #4 x 4'-6"	3 - #4 x 4'-6"	3 - #4 x 5'-0"	3 - #4 x 5'-0"	3 - #4 x 5'-0"	3 - #4 x 5'-6"						
NUMBER & LENGTH #5 BT BOTTOM TENSION BARS ϕ EACH END	2 - #5 x 4'-0"	2 - #5 x 4'-0"	2 - #5 x 4'-6"	2 - #5 x 4'-6"	2 - #5 x 4'-6"	2 - #5 x 5'-0"	2 - #5 x 5'-0"	2 - #5 x 5'-0"	2 - #5 x 5'-6"	2 - #5 x 5'-6"	2 - #5 x 6'-0"						
DESIGN CAMBER Δ = POSITIVE (UP) (INCHES)	ϕ RELEASE	0.13	0.14	0.16	0.17	0.28	0.30	0.40	0.42	0.59	0.62	0.63					
	ϕ ERECTION	0.21	0.24	0.26	0.27	0.45	0.47	0.64	0.65	0.93	0.95	0.95					
	ϕ FINAL	0.27	0.29	0.30	0.30	0.53	0.53	0.71	0.69	1.03	0.99	0.92					
NO OF INSERTS REQD.																	
NUMBER & SPACING OF TL-2 GUARDRAIL INSERTS	END OF BEAM TO ℓ OF FIRST INSERT EA. END																
	SEE NOTE 6 ℓ OF 1st INSERT TO ℓ OF 2nd INSERT EA. END																
WEIGHT OF TYPICAL BEAM INCLUDING DIAPHRAGM (TONS)	5.6	6.1	6.6	7.1	7.6	8.1	8.6	9.1	9.6	10.1	10.6						

MIN. CONCRETE STRENGTH @ RELEASE = 5500 PSI
 MIN. CONCRETE STRENGTH @ 28 DAYS = 8000 PSI
 INITIAL PULL/STRAND = 33,820 LBS
 CROSS-SECTION AREA/STRAND = 0.167 SQ. IN.

NOTES:

- BEAM WEIGHTS LISTED IN THE DESIGN TABLE ARE BASED ON ZERO SKEW, 2 FT. LONG ENDBLOCK AND DIAPHRAGMS SPACED @ 15 FT C/C. WEIGHTS FOR SKEWED BEAMS, LONGER ENDBLOCKS AND ADDITIONAL DIAPHRAGMS SHOULD BE ADJUSTED ACCORDINGLY. FOR ADDITIONAL DIAPHRAGMS, ADD 135 LBS/DIAPHRAGM. FOR SKEW ADD 17 LBS/DEGREE OF SKEW/END. FOR LONGER ENDBLOCK, ADD 163 LBS/LF/END.
- DESIGNERS SHOULD NOTE THAT DATA IN STANDARD TABLE IS BASED ON EVEN SPAN LENGTHS, A TWO LANE STRUCTURE 8 BEAMS WIDE AND ZERO SKEW. SUPERIMPOSED DEAD LOADS INCLUDE TYPE F PARAPET (321 PLF) AND A FWS OF 50 PSF. FOR NON-STANDARD BRIDGES DATA SHOULD BE VERIFIED AND IF REQUIRED NEW DESIGN DATA ENTERED INTO BLANK COLUMNS. IN NO CASE SHALL THE STANDARD DESIGN TABLE BE ALTERED.
- PREDICTED DESIGN CAMBER VALUES LISTED IN THE TABLE ARE BASED ON EMPIRICAL FORMULAS AND AS SUCH ARE APPROXIMATE. FOR MEMBERS WITH SPAN-TO-DEPTH RATIOS AT OR EXCEEDING 25, THE TOLERANCE VALUES LISTED IN APPENDIX B OF PCI MANUAL FOR QUALITY CONTROL, MN-116, MAY NOT APPLY. MEASUREMENT OF CAMBER FOR COMPARISON TO PREDICTED DESIGN VALUES SHOULD BE COMPLETED WITHIN 72 HOURS OF RELEASE. ADDITIONALLY, CAMBER SHOULD BE EVALUATED UNDER CONDITIONS THAT MINIMIZE THE EFFECT OF TEMPERATURE VARIATION.

- DESIGNER, FABRICATOR, AND ERECTOR SHALL BE AWARE THAT SKEWED END BEAMS MAY TWIST OR WARP, CAUSING UNEVEN BEAM SEATING AT THE BEARINGS. THE CONTRACTOR IS REQUIRED TO CORRECT AT THE TIME OF ERECTION, BEFORE THE BEAMS ARE SECURED IN PLACE. METHOD OF CORRECTION SHALL PROVIDE AN EVEN, TOTAL BEARING AND A LEVEL TOP BEAM SURFACE. TOLERANCE, AFTER CORRECTION, SHALL BE (1/4) 1/8 INCH. THE FABRICATOR SHALL NOTIFY THE CONTRACTOR AND DESIGNER IF CORRECTIONS ARE REQUIRED PRIOR TO SHIPMENT.
- MAXIMUM BEAM SKEW SHALL BE 30 DEGREES.
- DESIGNER INPUT VALUES OF NUMBER OF INSERTS, DISTANCE FROM END OF BEAM TO ℓ FIRST INSERT, AND ℓ SECOND INSERT. ABOVE VALUES SHALL BE BASED ON THE REQUIRED 6'-3" GUARDRAIL POST SPACING ACROSS THE BRIDGE.
- SPECIAL STRAND NOTE FOR 17" BOX SECTION ONLY: WHEN TL-2 GUARDRAIL INSERTS ARE REQUIRED THE BOTTOM INSERT (TYPE 2A ANCHOR) CONFLICTS WITH STRAND NO. 15. STRANDS 15 AND 16 HAVE BEEN MOVED TO POSITIONS 17 AND 18. FOR UNIFORMITY PURPOSES, ALL BEAMS OF THE SAME DESIGN SHALL USE SAME STRAND PATTERN.
- THIS SHEET SHALL BE USED IN CONJUNCTION WITH STANDARD SHEETS BR-B17A, BR-B100, BR-B101, BR-B102A & B, BR-B103, BR-B104, BR-B105A & B AND BR-B106 AS APPLICABLE.

APPROVED: *Gregory B. ...* 07-02-07
 WEST VIRGINIA DEPARTMENT OF TRANSPORTATION
 DIVISION OF HIGHWAYS
 ENGINEERING DIVISION
 DESIGN TABLE FOR 17"
 PRESTRESSED BOX BEAM
 STANDARD SHEET BR-B17B

WEST VIRGINIA DEPARTMENT OF TRANSPORTATION
 DIVISION OF HIGHWAYS
 ENGINEERING DIVISION

Right Fork of Mill Creek Bridge
 over
 Right Fork of Mill Creek

DESIGNED BY/TM/
 DRAWN BY/TM/
 CHECKED BY/TM/
 REVIEWED BY/TM/
 DATE:
 SCALE:
 SHEET NO. OF
 BRIDGE NUMBER

DESIGN TABLE FOR 17"
 PRESTRESSED BOX BEAM

GOVERNING SPECIFICATIONS

THE WEST VIRGINIA DEPARTMENT OF TRANSPORTATION, DIVISION OF HIGHWAYS STANDARD SPECIFICATIONS FOR ROADS AND BRIDGES, ADOPTED 2012 AS AMENDED BY THE CURRENT SUPPLEMENTAL SPECIFICATIONS, THE CONTRACT PLANS AND CONTRACT SPECIAL PROVISIONS ARE THE GOVERNING PROVISIONS APPLICABLE TO THIS PROJECT.

ALL BEAMS ARE DESIGNED IN ACCORDANCE WITH THE AASHTO LRFD BRIDGE DESIGN SPECIFICATIONS, DATED 1998 AS AMENDED BY THE 2003 INTERIM SPECIFICATIONS.

DESIGN NOTES

ALL STANDARD ADJACENT PRESTRESSED CONCRETE BRIDGE BEAMS ARE DESIGNED TO MEET THE FOLLOWING CRITERIA:

- DESIGN LOADS:
 - HL-93 LIVE LOAD IN ACCORDANCE WITH THE AASHTO LRFD BRIDGE DESIGN SPECIFICATIONS.
 - FUTURE WEARING SURFACE OF 50 PSF OF ROADWAY.
 - TYPE F PARAPET WEIGHING 321 PLF.
 - DIAPHRAGM DEAD LOAD, NUMBER REQUIRED BASED ON 15'-0" MAX. SPACING.
- TWO LANE BRIDGE WITH AN OVERALL WIDTH OF 24'-5" (INCL. 3/4" GAP BETWEEN ADJ. BEAMS), A CURB-TO-CURB WIDTH OF 22'-1", TRANSVERSE POST-TENSIONING, AND ZERO SKEW.
- DESIGN STRENGTH AND UNIT STRESSES:

MINIMUM CONCRETE STRENGTH @ STRAND RELEASE	6000 PSI
MINIMUM CONCRETE STRENGTH @ 28 DAYS	8000 PSI
TEMPORARY STRESS LIMITS IN CONCRETE BEFORE LOSSES:	
COMPRESSION STRESS LIMIT @ STRAND RELEASE	3600 PSI
TENSION STRESS LIMIT @ STRAND RELEASE	-200 PSI
COMPRESSIVE STRESS LIMITS IN CONCRETE @ SERVICE I AFTER LOSSES:	
@ FINAL I (PS-DL-LI)	4800 PSI
@ FINAL 2 (PS-DL)	3600 PSI
@ FINAL 3 (SOX(PS-DL-LI))	3200 PSI
TENSILE STRESS LIMIT IN CONCRETE @ SERVICE III AFTER LOSSES:	
@ FINAL I (PS-DL-LI)	-270 PSI
TENSION STRESS LIMIT PRIOR TO TRANSFER	202.5 KSI
TENSION STRESS LIMIT AFTER ALL LOSSES	194.4 KSI
- DEBONDING OR SHIELDING OF STRANDS TO REDUCE TEMPORARY TENSILE STRESSES IS PERMITTED, HOWEVER DEBONDING IS LIMITED TO 40% PER ROW AND 25% TOTAL. IN NO INSTANCES SHALL OUTER STRANDS BE DEBONDED. DEBONDED STRANDS SHALL BE SEPARATED BY AT LEAST ONE FULLY BONDED STRAND AND SHALL BE SYMMETRICAL ABOUT THE C OF THE BEAM. SHIELDING OF STRANDS SHALL BE ACCOMPLISHED BY TAPING OR TIGHT FITTING PLASTIC TUBES TAPED AT EACH END.
- THE ELASTOMERIC BEARING PADS PROVIDED IN THE STANDARD DESIGNS ARE BASED ON ZERO GRADE AND ARE LIMITED TO A MAXIMUM OF 5% GRADE. IN INSTANCES OF GRADES EXCEEDING THIS LIMIT, PADS SHALL BE SPECIFICALLY DESIGNED. INDIVIDUAL PAD DESIGNS SHALL BE IN ACCORDANCE WITH SECTION 14, AASHTO LRFD. BEVELED SOLE PLATES ARE PERMITTED.
- MAXIMUM BEAM SKEW SHALL BE 30 DEGREES.
- WHEN ALTERNATE DESIGNS OR SITE SPECIFIC DESIGNS ARE PROVIDED, CRITERIA SET FORTH IN THESE STANDARDS SHALL APPLY.
- NEGATIVE DESIGN CAMBER AFTER ALL LOSSES IS NOT PERMITTED.
- EACH BEAM PROVIDED IN THESE STANDARD DESIGNS HAS BEEN LOAD RATED IN ACCORDANCE WITH SECTION 3.15 OF THE WEST VIRGINIA DIVISION OF HIGHWAYS BRIDGE DESIGN MANUAL, 2004. ADDITIONALLY, LOAD RATING PROCEDURES ARE IN ACCORDANCE WITH THE AASHTO MANUAL FOR CONDITION EVALUATION AND LOAD AND RESISTANCE FACTOR RATING OF HIGHWAY BRIDGES, 2003.

LAP SPLICE TABLE			
BAR SIZE	NO. 3	NO. 4	NO. 5 NO. 6
SPLICE LEN.	21"	26"	34" 41"

THIS SHEET SHALL BE USED IN CONJUNCTION WITH STANDARD SHEETS BR-017A & B THRU BR-042A & B, BR-0101, BR-0102A & B, BR-0103, BR-0104, BR-0105A & B AND BR-0106 AS APPLICABLE.

MATERIALS & FABRICATION NOTES

* THE PRESTRESSED CONCRETE BEAMS SHALL CONFORM TO ALL APPLICABLE PROVISIONS OF SECTION 603 OF THE STANDARD SPECIFICATIONS.

MILD REINFORCEMENT:

- * ALL MILD REINFORCING STEEL SHALL BE GRADE 60, DEFORMED BILLET STEEL AND SHALL BE EPOXY COATED EXCEPT WHERE NOTED. ALL UNDATED REINFORCING SHALL MEET THE REQUIREMENTS OF AASHTO M31. ALL EPOXY COATED REINFORCING SHALL MEET THE REQUIREMENTS OF AASHTO M284, EXCEPT WHERE AMENDED BY SECTION 709.1 OF THE STANDARD SPECIFICATIONS.
- * ALL TENSION LAP SPLICES SHALL BE A CLASS B, CONTACT TYPE, MINIMUM LAP SPLICE LENGTHS SHALL BE AS GIVEN IN THE "LAP SPLICE TABLE", THIS SHEET, ADDITIONALLY, IF LAP SPLICING OF ET, LR, AND BT BARS IS USED, TERMINATION OF THE SPLICE SHALL BE NO CLOSER TO THE END OF THE BEAM THAN 1/10 OF THE SPAN LENGTH.
- * MINIMUM BAR BENDING DIAMETER SHALL BE 6 BAR DIAMETERS, EXCEPT THAT NO. 4 AB BARS MAY HAVE A MINIMUM BEND DIAMETER OF 4 BAR DIAMETERS.
- * MINIMUM CONCRETE COVER SHALL BE AS SPECIFIED IN SECTION 603.5 OF THE STANDARD SPECIFICATIONS, EXCEPT WHERE NOTED ON THE PLANS.

PRESTRESSING STRAND:

- * ALL PRESTRESSING STEEL SHALL BE 1/2" #, GRADE 270, 7 WIRE UNCOATED, LOW-RELAXATION STRAND MEETING THE REQUIREMENTS OF AASHTO M203, SUPPLEMENT S1.
- * ALL BEAMS DESIGNED IN THESE STANDARDS UTILIZE STRANDS WITH A NOMINAL AREA OF 0.167 SQ. IN. STRANDS WITH A NOMINAL AREA OF 0.153 SQ. IN. IS PERMITTED FOR INDIVIDUAL OR ALTERNATE DESIGNS, HOWEVER THE DESIGNER IS ENCOURAGED TO USE THE LARGER STRAND FOR UNIFORMITY REASONS. IN NO CASES WILL STRESS-RELIEVED STRAND BE PERMITTED.
- * ALL STRANDS SHALL BE ENCLOSED INSIDE THE STIRRUP CAGE FOR THE FULL LENGTH OF THE BEAM.
- * ALL EXPOSED PRESTRESSING STRAND AT EACH BEAM END SHALL BE SHDPC COATED WITH A LIQUID COLD-APPLIED BITUMINOUS ELASTOMERIC WATERPROOFING MEMBRANE. MATERIAL SHALL MEET ASTM 0836-84.

CONCRETE:

- * ALL CONCRETE USED IN MANUFACTURING PRESTRESSED CONCRETE BEAMS SHALL MEET THE REQUIREMENTS OF SECTION 603.6 OF THE STANDARD SPECIFICATIONS. DESIGN STRENGTHS SHALL MEET OR EXCEED THE MINIMUM VALUES SET FORTH IN THESE PLANS.
- * ALL CONCRETE USED IN PARAPETS AND CURBS SHALL BE CLASS K CONCRETE.
- * ELASTOMERIC BEARING PADS:
 - * ALL BEARING PADS SHALL MEET THE APPLICABLE REQUIREMENTS AS SET FORTH IN SECTION 18.2 OF THE AASHTO LRFD BRIDGE CONSTRUCTION SPECIFICATIONS, 1998 EDITION WITH CURRENT INTERIMS. ALL BEARINGS SHALL BE STEEL REINFORCED LAMINATED BEARINGS.
 - * THE ELASTOMER MATERIAL SHALL BE 60 DUROMETERS WITH A MINIMUM LOW TEMPERATURE GRADE OF 3 (ZONE C).
 - * ALL STEEL REINFORCING SHALL MEET THE REQUIREMENTS OF AASHTO M270, GRADE 36.

GUARDRAIL, GUARDRAIL POSTS, TUBING & INSERTS:

- * ALL W-BEAM GUARDRAIL AND ATTACHMENT HARDWARE SHALL BE IN ACCORDANCE WITH SECTION 712.4 OF THE STANDARD SPECIFICATIONS. GUARDRAIL POSTS, STRUCTURAL TUBING, POST ATTACHMENT INSERTS, AND HARDWARE SHALL MEET THE LISTED MATERIAL AND COATING SPECIFICATIONS:

ITEM	DESCRIPTION	MATERIAL SPEC.	COATING SPEC.
POST	W6x25	AASHTO M270, GR 36	AASHTO M111
PLATE	1/2" x 7"	AASHTO M270, GR 36	AASHTO M111
TUBING	TS 8x4x3/16	ASTM A500, GR B	AASHTO M111
CHANNEL	C7x9.8	AASHTO M270, GR 36	AASHTO M111
FERRULE	TYPE 2A 1/4" # x 2 1/2" MIN LEN.	ASTM A108 (11L17 STEEL)	AASHTO M232
WIRE	ANCHOR 3/8"	ASTM A510 (1018 STEEL)	AASHTO M232
STUDS	1/4" # x 8" LONG	ASTM A108 (1045 C.D. STEEL)	AASHTO M232
NUTS	1/4" #	AASHTO M291, CLASS C	AASHTO M232
COUPLERS	TYPE 1A 1/4" # x 5" LONG	ASTM A108 (12L14 STEEL)	AASHTO M232
BOLTS	ANCHOR 1/4" # x 12" LONG	AASHTO M164 (TYPE 1, HH)	AASHTO M232
BOLTS	1/4" # x ALL LEN.	AASHTO M164 (TYPE 1, HH)	AASHTO M232
NUTS	3/8" #	AASHTO M291, CLASS C	AASHTO M232
WASHERS	ALL	AASHTO M293	AASHTO M232

WELDING:

- * TACK WELDING OF REINFORCEMENT IS NOT PERMITTED. REINFORCING CAGES AND LONGITUDINAL STEEL SHALL BE ADEQUATELY TIED WITH APPROVED MEANS TO PREVENT RACKING AND MISALIGNMENT.
- * ALL WELDING OF FABRICATED ITEMS, AS SHOWN IN THESE PLANS SHALL BE IN ACCORDANCE WITH ALL APPLICABLE PROVISIONS OF AASHTO/AWS D1.5, 2002.

POST-TENSIONING BARS:

- * POST - TENSIONING THREAD BARS SHALL BE ONE INCH DIAMETER, 150 KSI STEEL, AND SHALL CONFORM TO AASHTO M275, TYPE II. STEEL THREAD BARS SHALL BE DESIGNED TO ALLOW THE USE OF HEAVY HEX NUTS AND COUPLERS THAT THREAD INTO THE END OF THE DEFORMATIONS. HEAVY HEX NUTS AND COUPLERS SHALL BE OF A DESIGN AND MATERIAL RECOMMENDED BY THE BAR MANUFACTURER TO DEVELOP THE FULL TENSILE STRENGTH OF THE BAR. PROPERLY DOCUMENTED CERTIFIED MILL TEST REPORTS SHALL BE PROVIDED FOR EACH HEAT OF STEEL THREAD BARS.
- * ALL POST-TENSIONING THREAD BARS, NUTS, BEARING PLATES, COUPLERS, AND ANCILLARY HARDWARE SHALL BE HOT-DIPPED GALVANIZED IN ACCORDANCE WITH AASHTO M111. THE GALVANIZING PLANT SHALL ADMINISTER ADEQUATE QUALITY CONTROL MEASURES TO SAFEGUARD AGAINST HYDROGEN EMBRITTLMENT. QUALITY CONTROL MEASURES SHALL COMPLY WITH ASTM A-143. CERTIFICATION FOR HOT-DIP GALVANIZING SHALL BE PROVIDED BY THE GALVANIZING PLANT.
- * ALL POST-TENSIONING BEARING PLATES SHALL CONFORM TO AASHTO M270, GRADE 36.

SHEAR KEY GROUT:

- * SHEAR KEY GROUT SHALL BE A GROUT THAT IS RECOMMENDED BY THE MANUFACTURER FOR A POURABLE GROUT APPLICATION AND THAT BASED ON THE MANUFACTURER'S TEST DATA WILL ATTAIN A MINIMUM OF 4500 PSI COMPRESSIVE STRENGTH IN 3 DAYS UNDER CONDITIONS REPRESENTATIVE OF THE CONDITIONS TO BE EXPERIENCED AT THE SITE. THE GROUT MUST BE LISTED ON THE APPROVED LIST OF GROUTS PUBLISHED BY THE WEST VIRGINIA DIVISION OF HIGHWAYS, MATERIALS CONTROL, SOIL AND TESTING DIVISION. THE CONTRACTOR SHALL PRE-TEST THE PROPOSED GROUT FOR COMPRESSIVE STRENGTH AT 3 AND 7 DAYS AND SUBMIT THE RESULTS TO THE BRIDGE PROJECT MANAGER FOR APPROVAL PRIOR TO INSTALLATION OF THE GROUT IN THE STRUCTURE. THE TESTS WILL BE BASED ON A POURABLE CONSISTENCY WITH THE SAME WATER/GROUT MIXTURE RATIO TO BE USED IN THE STRUCTURE.
- * THE CONTRACTOR SHALL BE REQUIRED TO SUBMIT FOR EACH PROJECT, THE GROUT PRE-TEST RESULTS OBTAINED IN THE NOTE ABOVE. THE CONTRACTOR SHALL BE REQUIRED TO PERFORM A NEW PRE-TEST AND SUBMISSION FOR APPROVAL UNDER ANY OF THE FOLLOWING CONDITIONS:
 - * A PERIOD OF 18 MONTHS HAS ELAPSED SINCE LAST PRE-APPROVAL TESTING.
 - * GROUT MANUFACTURER HAS REVISED OR CHANGED THE GROUT SPECIFICATIONS.
 - * THE CONTRACTOR ALTERS THE WATER/GROUT MIXTURE RATIO.
 - * THE CONTRACTOR CHANGES GROUT MANUFACTURER.
- * THE CONTRACTOR IS REQUIRED TO COMPLETE THE GROUT STRENGTH TABLE ON BR-0103.
- * TEST PROCEDURE FOR DETERMINING THE COMPRESSIVE STRENGTH OF GROUT SHALL USE CUBE SPECIMENS IN ACCORDANCE WITH ASTM C109, AS MODIFIED BY ASTM C1107. GROUT TESTING IN ACCORDANCE WITH AASHTO T23 (STANDARD CYLINDER TEST) IS NOT ACCEPTABLE.

PROTECTIVE SURFACE TREATMENT:

- * EACH PRESTRESSED CONCRETE BEAM SHALL BE TREATED BY THE MANUFACTURER AT THE FABRICATION PLANT WITH AN APPROVED CONCRETE SEALER (ISLAND). AN APPROVED LIST OF CONCRETE SEALERS ARE ON FILE AT THE WEST VIRGINIA DIVISION OF HIGHWAYS, MATERIALS CONTROL, SOIL AND TESTING DIVISION. COVERAGE SHALL INCLUDE TOP AND BOTTOM OF INTERIOR BEAMS, AND TOP, BOTTOM AND EXTERIOR SIDE OF EXTERIOR BEAM. APPLICATION RATE SHALL BE PER TREATMENT MANUFACTURER'S RECOMMENDATION.
- * AFTER COMPLETION OF THE SILANE TREATMENT BY FABRICATOR AND A MAXIMUM OF FIVE WORKING DAYS PRIOR TO SHIPMENT OF THE BEAMS, THE FABRICATOR SHALL BE RESPONSIBLE FOR ABRASIVE BLAST CLEANING TO CLEAN WHITE CONCRETE THE INTERIOR SIDES OF BEAMS FOR THE FULL LENGTH. CLEAN WHITE CONCRETE SHALL MEAN REMOVAL OF ALL DIRT, GREASE, OIL, AND LOOSE CONCRETE LANTANCE AND PROVIDE A ROUGHENED CONCRETE SURFACE. BLASTING MEDIUM SHALL BE APPROVED BY THE DIVISION OF HIGHWAYS.

SHOP DRAWINGS:

- * THE FABRICATOR SHALL BE RESPONSIBLE FOR THE PREPARATION OF SHOP DRAWINGS IN ACCORDANCE WITH THE WEST VIRGINIA DIVISION OF HIGHWAYS DOCUMENTS: 00-102 AND THE STANDARD SPECIFICATIONS. ADDITIONAL INFORMATION IS PROVIDED IN SECTION 7 OF THE BRIDGE DESIGN MANUAL. SHOP DRAWINGS SHALL INCLUDE THE FABRICATOR'S DETENSIONING PLAN.

WEST VIRGINIA DEPARTMENT OF TRANSPORTATION
DIVISION OF HIGHWAYS
ENGINEERING DIVISION

PREPARED: 07-02-07
REVIEWED:

PRESTRESSED CONCRETE BEAM
DESIGN & ASSEMBLY NOTES
STANDARD SHEET BR-0100

WEST VIRGINIA DEPARTMENT OF TRANSPORTATION
DIVISION OF HIGHWAYS
ENGINEERING DIVISION

Right Fork of Mill Creek Bridge
over
Right Fork of Mill Creek

PRESTRESSED CONCRETE BEAM
DESIGN & ASSEMBLY NOTES

DESIGNED BY/TM/	
DRAWN BY/TM/	
CHECKED BY/TM/	
REVIEWED BY/TM/	
DATE:	
SCALE:	
SHEET NO. OF	
BRIDGE NUMBER	

PUBLIC ROADS DIST.	STATE DIST. NO.	PROJECT NUMBER	COUNTY	SHEET NO.	TOTAL SHEETS
W.VA.	02	S350-362-3.62	WAYNE	4	10

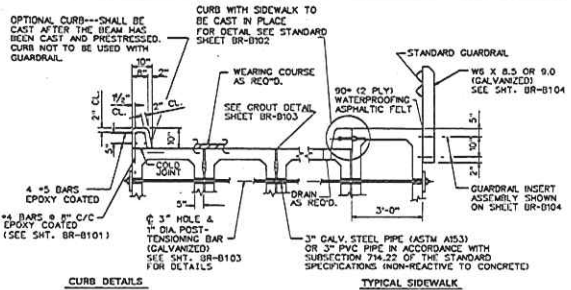

TYP. BEAM CROSS SECTION AND POST-TENSIONING BAR DETAILS

TO FACILITATE GUARDRAIL FABRICATION, STANDARD LENGTH GALVANIZED GUARDRAIL BEAMS MAY BE SAW CUT TO REQUIRED LENGTHS WITH SPACER AND POST ATTACHMENT HOLES DRILLED IN THE REQUIRED LOCATIONS. HOLES TO BE 1" MAXIMUM DIAMETER REMOVE ALL BURRS AFTER DRILLING. NO REWORKING OF HOLES ALLOWED AFTER COMPLETION OF DRILLING OPERATIONS.

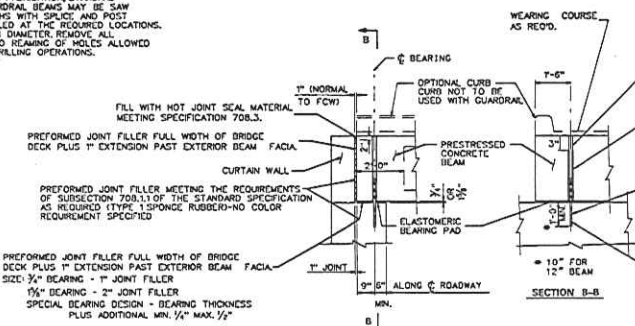

TYPICAL END BEARING DETAIL/BACKWALL (ALONG CENTER LINE ROADWAY)

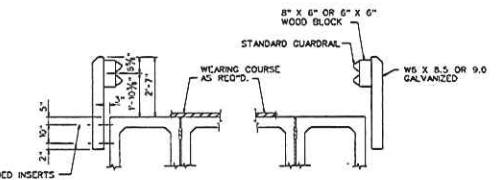

TYPICAL CROSS SECTION WITHOUT CURB

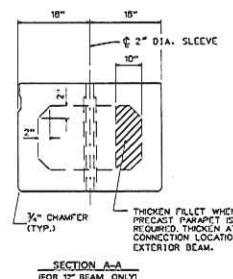

SECTION A-A (FOR 12" BEAM ONLY)

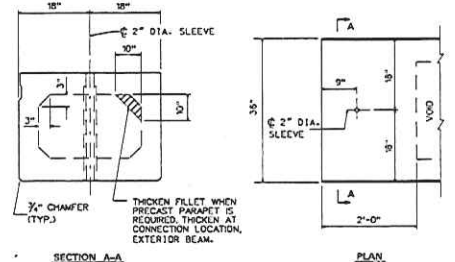

END BLOCK DETAILS

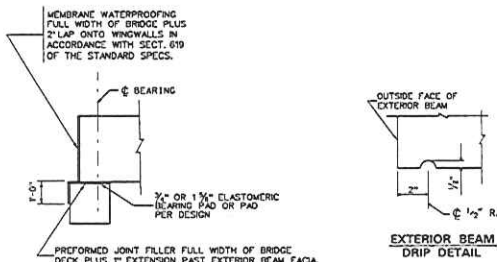

EXTERIOR BEAM DRIP DETAIL

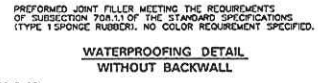

WATERPROOFING DETAIL WITHOUT BACKWALL

- GOVERNING SPECIFICATIONS.**
THE WEST VIRGINIA DIVISION OF HIGHWAYS STANDARD SPECIFICATIONS, ROADS AND BRIDGES, ADOPTED 1993, AS AMENDED BY THE SUPPLEMENTAL SPECIFICATIONS OF THE WEST VIRGINIA DIVISION OF HIGHWAYS, CURRENT ISSUE, THE CONTRACT PLANS AND CONTRACT DOCUMENTS ARE THE GOVERNING PROVISIONS APPLICABLE TO THE PROJECT.
- THE PRESTRESSED CONCRETE BOX BEAMS SHALL CONFORM TO ALL APPLICABLE PROVISIONS OF THE SECTION 603 OF THE STANDARD SPECIFICATIONS.
- ALL REINFORCING STEEL BARS SHALL BE INTERMEDIATE GRADE BILLET STEEL GRADE 60 IN ACCORDANCE WITH SUBSECTION 709.1 OF THE STANDARD SPECIFICATIONS. REINFORCING BARS SHALL BE EPOXY COATED IN ACCORDANCE WITH SECTION 713.5 OF THE STANDARD SPECIFICATIONS.
- DESIGN AND FABRICATION NOTES.**
- 1) ALL MEMBERS ARE DESIGNED FOR 1.25xHS20-44 (HS23) LIVE LOADING IN ACCORDANCE WITH 1992 AASHTO STANDARD SPECIFICATIONS FOR HIGHWAY BRIDGES AS AMENDED BY CURRENT INTERIM SPECIFICATIONS. THE DESIGN PROVIDES FOR A WEARING SURFACE OF 50 POUNDS PER SQUARE FOOT OF ROADWAY. THE DESIGN ALSO PROVIDES FOR AN ADDITIONAL GUARDRAIL SUPERIMPOSED DEAD LOAD OF 50 POUNDS PER LINEAR FOOT OF BEAM AND DIAPHRAGM DEAD LOAD BASED UPON NO. R20. THE DESIGN IS BASED ON A TWO-LANE BRIDGE WITH A DECK WIDTH OF 33'-8" AND A ROADWAY WIDTH OF 33'-7".
 - 2) COMPRESSIVE STRENGTH OF CONCRETE AT TIME OF PRESTRESSING (f_{ci}) SHALL NOT BE LESS THAN 1,400 PSI THRU 33" BOX BEAMS, 5,000 PSI 42" BOX BEAM.
 - 3) COMPRESSIVE STRENGTH OF CONCRETE AT 28 DAYS (f_c) SHALL NOT BE LESS THAN 13,000 PSI THRU 33" BOX BEAMS, 6,000 PSI 42" BOX BEAM.
 - 4) PRESTRESSING STEEL SHALL BE SEVEN-WIRE UNCOATED LOW RELAXATION STRAND IN ACCORDANCE WITH ASTM A416 GRADE 270 WITH MINIMUM TENSILE STRENGTH (f_{pu}) OF 270,000 PSI, EXCEPT FOR 42" BOX BEAM, PRESTRESSING STEEL SHALL BE SEVEN-WIRE UNCOATED LOW-RELAXATION OVERSIZE (AS-0.167 50.8) IN ACCORDANCE WITH ASTM A416 GRADE 270 WITH MINIMUM TENSILE STRENGTH (f_{pu}) OF 270,000 PSI.
 - 5) CALCULATED INITIAL STRESSES SHALL NOT EXCEED THE FOLLOWING ALLOWABLE TENSILE STRESSES BEFORE LOSSES DUE TO CREEP AND SHRINKAGE: CONCRETE COMPRESSION = 0.60 f_{ci}; CONCRETE TENSION = 200 PSI OR 3 f_{ci}; PRESTRESSING STEEL = 0.75 f_{pu} FOR LOW RELAX. STRAND.
 - 6) CALCULATED FINAL STRESSES SHALL NOT EXCEED THE FOLLOWING ALLOWABLE SERVICE LOAD STRESSES AFTER ALL LOSSES HAVE OCCURRED: CONCRETE COMPRESSION = 0.40 f_{ci}; CONCRETE TENSION = 3 f_{ci}; PRESTRESSING STEEL = 0.80 f_{pu}.
 - 7) WHERE THE CALCULATED INITIAL STRESSES EXCEED THE ALLOWABLE STRESS VALUES, STRAND DEBONDING OR TOP STRANDS SHALL BE PROVIDED TO REDUCE THE CALCULATED VALUES TO BELOW THE ALLOWABLE VALUES. ADDITIONALLY, BONDED NON-PRESTRESSED REINFORCEMENT SHALL BE PROVIDED TO RESIST THE TOTAL TENSION.
 - 8) ULTIMATE LOAD CAPACITY SHALL NOT BE LESS THAN $\frac{1.30}{\phi} [0L + \frac{1}{2} (LL + I)]$ WHERE $\phi = 1.0$ FOR FACTORY PRODUCED PRECAST PRESTRESSED MEMBERS.
 - 9) ALL ANCHOR DOWELS, NON-HEADED ANCHOR BOLTS, GUARDRAIL ATTACHMENT HARDWARE, GUARDRAIL POSTS, CONNECTION PLATES AND DRAP PLATES SHALL CONFORM TO AASHTO M33 AND SHALL BE HOT-DIP GALVANIZED IN ACCORDANCE WITH AASHTO M11, EXCEPT WHERE NOTED. ALL CAST-IN-PLACE THREADED INSERTS SHALL BE FABRICATED FROM HEX BAR STOCK MEETING THE REQUIREMENTS OF AASHTO M33, ASTM A108 OR A576, GRADE 1020 THRU 1035 OR GRADE 12L14. ALL GUARDRAIL POST ATTACHMENT BOLTS IN OR OUT OF CONCRETE SHALL MEET AASHTO M194 OR ASTM A307. NUTS AS REQUIRED SHALL BE HEAVY HEX AND SHALL MEET AASHTO M291 GRADE OF NUTS SUPPLIED SHALL BE AS SHOWN IN TABLE X11 OF M291. NUTS MAY ALSO BE SUPPLIED TO AASHTO M292 GRADE 2H WASHERS SHALL BE CIRCULAR CARBON STEEL MEETING THE REQUIREMENTS OF AASHTO M293. ALL BOLTS, NUTS AND WASHERS SHALL BE HOT-DIP GALVANIZED TO AASHTO M232.
 - 10) ALL WELDING TO BE ACCOMPLISHED PRIOR TO GALVANIZING, EXCEPT WHEN NOTED.
 - 11) GUARDRAIL END TERMINAL SECTIONS SHALL CONFORM TO THE REQUIREMENTS AS SET FORTH BY THE WEST VIRGINIA DEPARTMENT OF TRANSPORTATION STANDARD DETAILS BOOK VOLUME 1, CURRENT ISSUE.
 - 12) DEBONDING OF STRANDS SHALL BE ACCOMPLISHED BY TAPING OR TIGHT-FIT PLASTIC TUBING. LENGTH OF DEBONDING SHALL BE MEASURED FROM ENDS OF BEAM. DEBONDING SHALL BE ACCOMPLISHED BY SHELTING STRANDS IN A SYMMETRICAL FASHION ABOUT THE CL OF THE BEAM. NUMBER AND LENGTHS OF DEBONDED STRANDS FOR EACH SPAN LENGTH IS GIVEN IN THE PARTICULAR BEAMS DESIGN DATA TABLE. PLASTIC TUBING SHALL BE TAPED AT BOTH ENDS.
 - 13) WHEN ALTERNATE BEAMS ARE TO BE SUPPLIED, THEIR DESIGNS SHALL BE BASED ON LOAD FACTOR DESIGN AND ALLOWABLE STRESS DESIGN AT ALL LOAD STAGES. ADDITIONALLY, ALL BEAMS SHALL BE DESIGNED TO MINIMIZE CAMBER, BUT SHALL HAVE A POSITIVE (UPWARD) CAMBER AFTER ALL LOSSES.
 - 14) DEFINITIONS: JACKING FORCE=TOTAL PRESTRESS FORCE IN INDIVIDUAL STRAND BEFORE ANY LOSSES HAVE OCCURRED, AS DEFINED BY AASHTO SPECIFICATIONS. INITIAL PRESTRESS FORCE=TOTAL PRESTRESS FORCE IN BEAM AT SERVICE LOADS AFTER 10% LOSSES DUE TO ELASTIC SHORTENING, CREEP AND SHRINKAGE HAVE BEEN DEDUCTED. FINAL PRESTRESS FORCE=TOTAL PRESTRESS FORCE IN BEAM AT SERVICE LOADS AFTER ALL LOSSES HAVE OCCURRED.
 - 15) BRIDGE GRADE: DUE TO THE DESIGN OF THE STANDARD ELASTOMERIC BEARING PADS, BRIDGE GRADES SHALL BE LIMITED TO 5 PER CENT OR LESS WHEN USING THESE PADS. IN CASES WHERE THE GRADE MUST BE GREATER THAN 5 PER CENT, A SPECIALLY DESIGNED PAD WILL BE REQUIRED.
 - 16) DIMENSIONAL TOLERANCES SHALL BE AS SPECIFIED BY DIVISION VI, SECTION 6.4 OF THE P.C.I. "MANUAL FOR QUALITY CONTROL", 3RD EDITION.
 - 17) THIS SHEET TO BE USED WITH STANDARD SHEET BR-1 OR BR-1A, BR-S12A, BR-S12B, BR-B17A, BR-B17B, BR-B21A, BR-B21B, BR-B27A, BR-B27B, BR-B33A, BR-B33B, BR-B42A, BR-B42B, BR-B101, BR-B102, BR-B103, AND BR-B104 AS APPLICABLE.

DESIGNED BY	CHKD.
DRAWN BY	APP-00V
CHECKED BY	
INCH	
SCALE	NONE
PROJECT NO.	
	BRIDGE NUMBER

WEST VIRGINIA DEPARTMENT OF TRANSPORTATION
DIVISION OF HIGHWAYS - STRUCTURES

Right Fork of Mill Creek Bridge
over
Right Fork of Mill Creek

PRESTRESS CONCRETE BEAM
DESIGN & ASSEMBLY DETAILS

STANDARD SHEET BR-6100

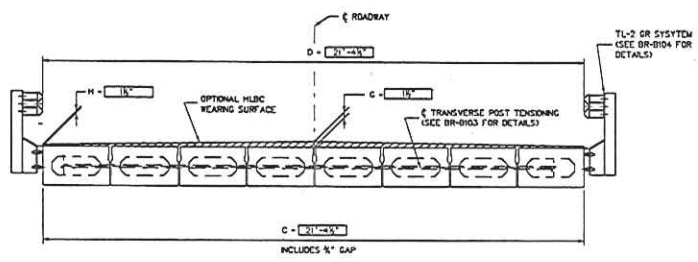

TYPICAL CROSS-SECTION WITH GUARDRAIL

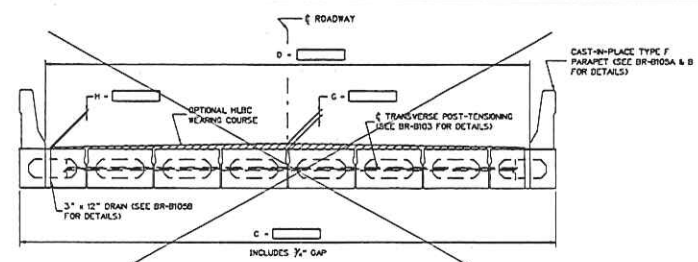

TYPICAL CROSS-SECTION WITH PARAPET OR CURB

CONTROL DIMENSIONS		
DESCRIPTION	CODE	VALUE
OVERALL BEAM LENGTH	A	41'-6"
SPAN LENGTH, ϵ BEARING TO ϵ BEARING	B	40'-0"
SUPERSTRUCTURE WIDTH - OUT TO OUT	C	21'-4 1/2"
ROADWAY WIDTH - FACE GR/PARAPET TO FACE GR/PARAPET	D	21'-4 1/2"
NUMBER OF BEAMS REQUIRED		7
BEAM SIZE (WIDTH x DEPTH)		36" x 17"
SKEW ANGLE (NORMAL, DEG. RFS OR DEG. LFS)	E	20° LFS
PERPENDICULAR DISTANCE FROM FACE OF BEAM TO ϵ BEARING	F	8 1/2"
HUBC WEARING COURSE REQUIRED (YES/NO)		No
THICKNESS OF WEARING COURSE # ϵ OF DECK OR ROADWAY	G	1 1/2"
THICKNESS OF WEARING COURSE # CODE OF DECK OR PARAPET	H	1 1/2"
TL-2 BRIDGE GUARDRAIL SYSTEM REQUIRED (YES/NO)		Yes
FABRICATOR TO SUPPLY TL-2 BRIDGE GUARDRAIL (YES/NO)		Yes
FABRICATOR TO INSTALL BRIDGE GUARDRAIL PRIOR TO SHIPMENT (YES/NO) (IF NO, FABRICATOR TO SHIP LOOSE)		Yes
NUMBER OF GUARDRAIL POST INSERTS REQUIRED PER SIDE		7
TYPIC F PARAPET REQUIRED (YES/NO)		No
DRAINS REQUIRED (YES/NO)		No
NUMBER OF DRAINS REQUIRED PER SIDE		N/A
10" CURB REQUIRED (YES/NO)		No

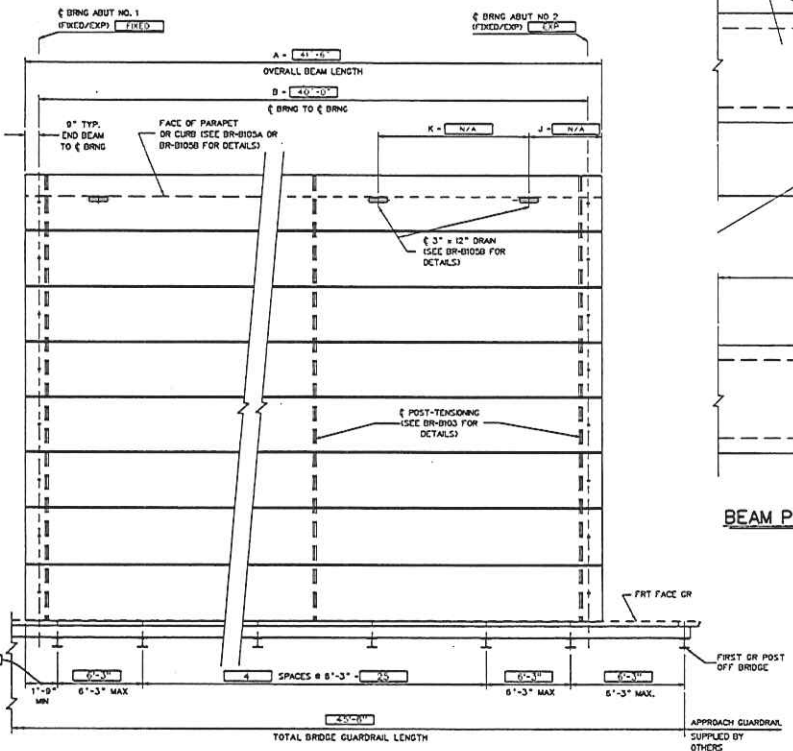

DECK PLAN VIEW

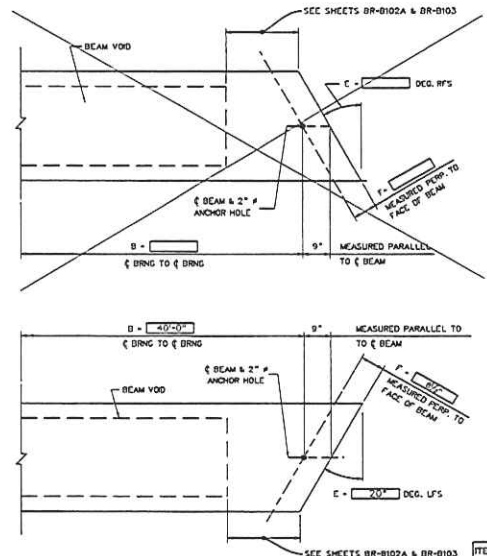

BEAM PLAN VIEW - SKEWED ENDS

ESTIMATE OF QUANTITIES

ITEM NO.	DESCRIPTION	UNITS	QUANTITY
603016	PRESTRESSED CONCRETE BOX BEAM	L ³	290.5

NOTES:
 1. WHEN BRIDGE GUARDRAIL IS TO BE SUPPLIED BY THE BEAM FABRICATOR, COST OF ALL BRIDGE GUARDRAIL ITEMS TO INCLUDE POSTS, RAIL ELEMENTS, ATTACHMENT HARDWARE, AND MISCELLANEOUS ITEMS NEEDED TO COMPLETELY INSTALL BRIDGE GUARDRAIL SHALL BE INCLUDED IN ITEM 603016 "PRESTRESSED CONCRETE BOX BEAM."
 2. THIS SHEET SHALL BE USED IN CONJUNCTION WITH STANDARD SHEETS BR-B17A & B THRU BR-B42A & B, BR-B100, BR-B102A & B, BR-B103, BR-B104, BR-B105A & B AND BR-B106.

APPROVED: [Signature] DATE: 05-07
 WEST VIRGINIA DEPARTMENT OF TRANSPORTATION
 DIVISION OF HIGHWAYS
 ENGINEERING DIVISION
 PREPARED: 07-02-07
 DESIGN AND ASSEMBLY NOTES
 STANDARD SHEET BR-B101

WEST VIRGINIA DEPARTMENT OF TRANSPORTATION
 DIVISION OF HIGHWAYS
 ENGINEERING DIVISION

Right Fork of Mill Creek Bridge
 over
 Right Fork of Mill Creek

PRESTRESSED CONCRETE BEAM
 DESIGN & ASSEMBLY NOTES

DESIGNED BY/THRU	
DRAWN BY/THRU	
CHECKED BY/THRU	
REVIEWED BY/THRU	
DATE:	
SCALE:	
SHEET NO. OF	
BRIDGE MANUAL	

STATE PROJECT NUMBER	FEDERAL PROJECT NUMBER	STATE DIST. NO.	COUNTY	SHEET NO.	TOTAL SHEETS
S350-362-3.62		02	WAYNE	6	10

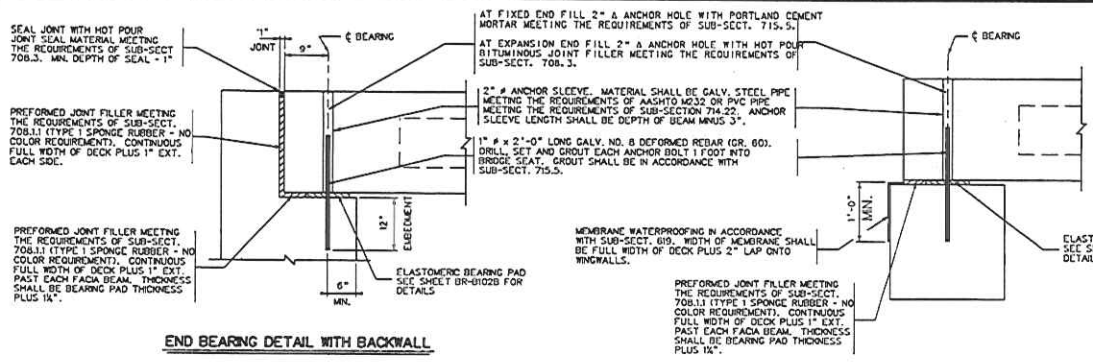

END BEARING DETAIL WITH BACKWALL

END BEARING DETAIL WITHOUT BACKWALL

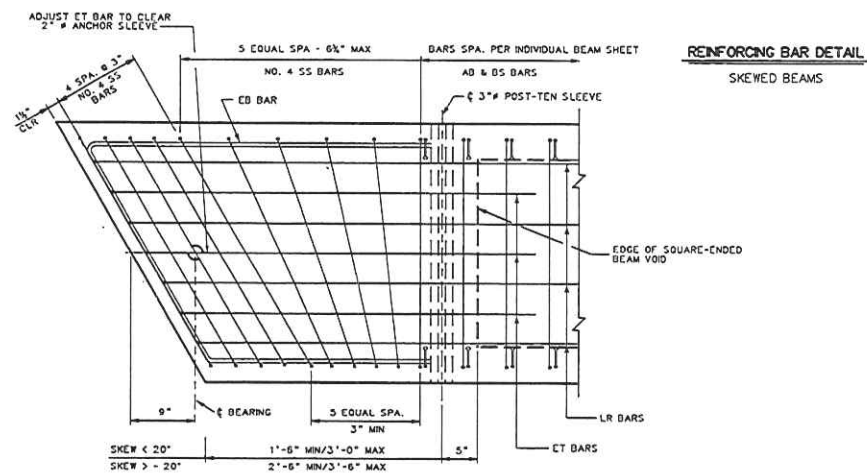
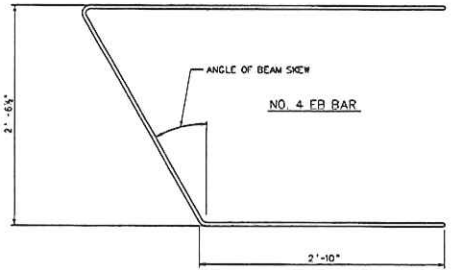
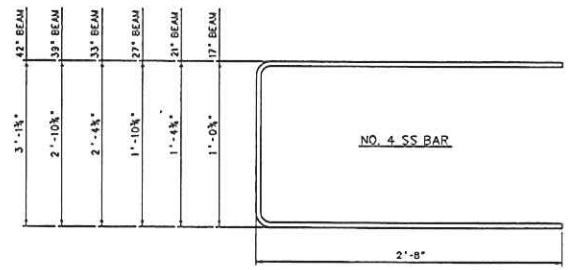

END BLOCK DETAIL - SKEWED BEAMS

WO/POST-TEN. ACCESS POCKET

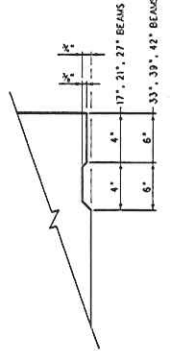

THIS SHEET SHALL BE USED IN CONJUNCTION WITH STANDARD SHEETS BR-617A & B THRU BR-617A & B, BR-6102, BR-6103, BR-6104, BR-6105A & B AND BR-6106 AS APPROPRIATE.

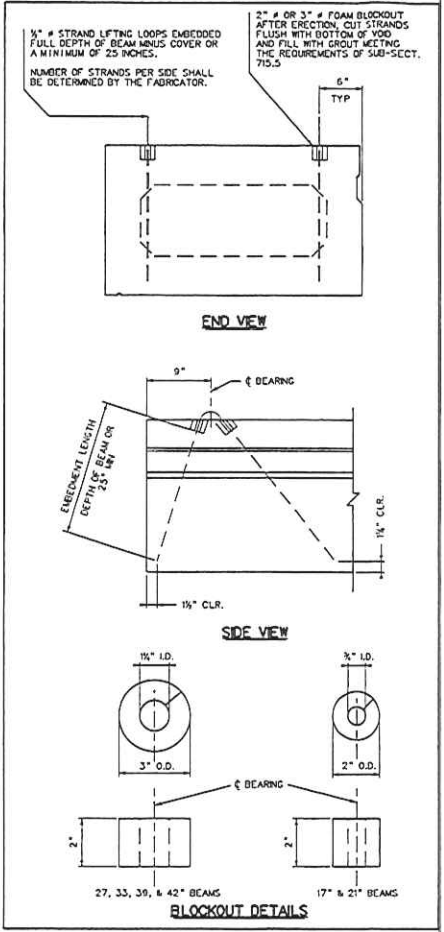

APPROVED: <i>Gregg Bailey</i>	DATE: 10-25-07
DIRECTOR, DESIGNING DIVISION	
WEST VIRGINIA DEPARTMENT OF TRANSPORTATION	PREPARED: 07-02-07
DIVISION OF HIGHWAYS	
ENGINEERING DIVISION	REVISION:
PRESTRESSED CONCRETE BEAM	
SKEWED END REINFORCING	
MISC. DESIGN AND ASSEMBLY DETAILS	
STANDARD SHEET BR-8102A	

WEST VIRGINIA DEPARTMENT OF TRANSPORTATION DIVISION OF HIGHWAYS ENGINEERING DIVISION	
DESIGNED BY: THW	
DRAWN BY: THW	
CHECKED BY: THW	
REVIEWED BY: THW	
DATE:	
SCALE:	
SHEET OF BRIDGE NO.	

Right Fork of Mill Creek Bridge
over
Right Fork of Mill Creek

PRESTRESSED CONCRETE BEAM
SKEWED END REINFORCING
MISC. DESIGN AND ASSEMBLY DETAILS

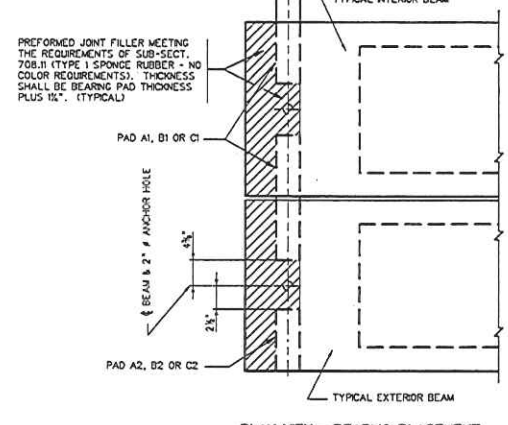
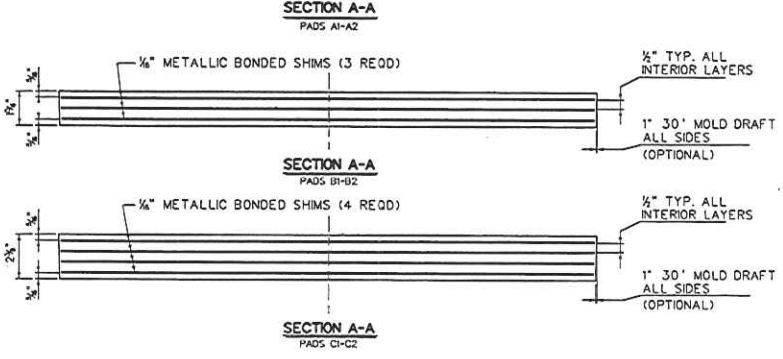
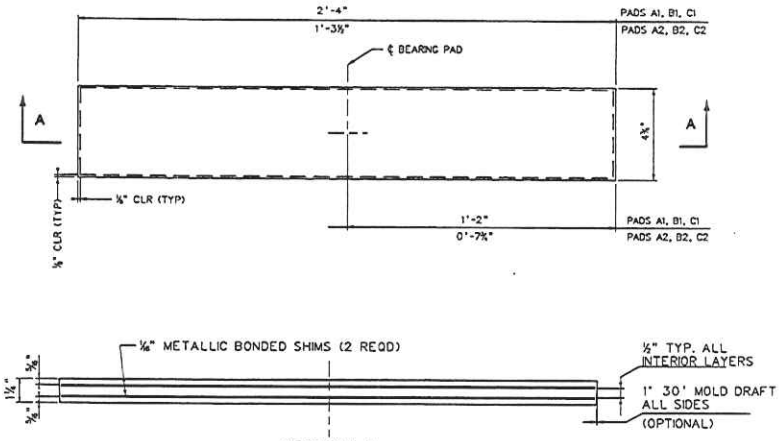

PLAN VIEW - BEARING PLACEMENT
NORMAL BEAMS

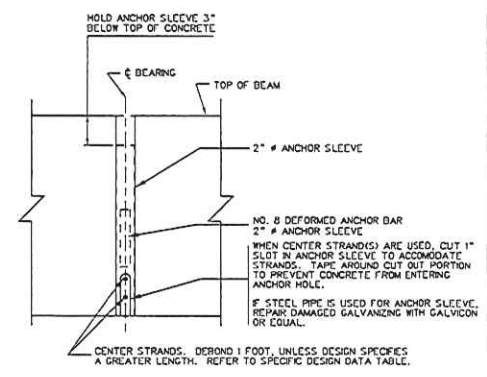

ANCHOR SLEEVE DETAIL

PREFORMED JOINT FILLER MEETING THE REQUIREMENTS OF SUB-SECT. 708.11 (TYPE 1 SPONGE RUBBER - NO COLOR REQUIREMENTS). THICKNESS SHALL BE BEARING PAD THICKNESS PLUS 1/4". (TYPICAL)

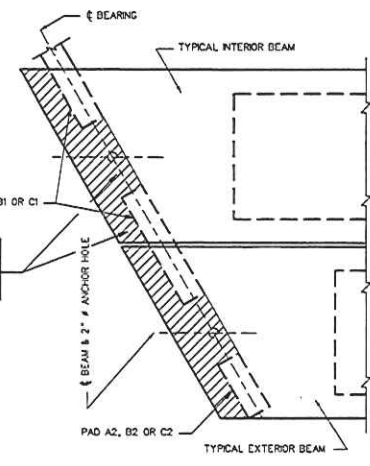

PLAN VIEW - BEARING PLACEMENT

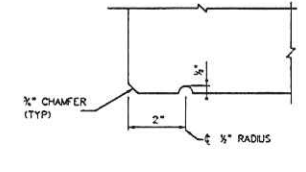

DRIP GROOVE DETAIL
EXTERIOR BEAMS

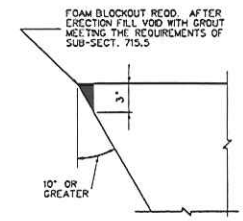

SKREW BLOCKOUT DETAIL

NOTES:

- ELASTOMERIC BEARING PADS ARE DESIGNED IN ACCORDANCE WITH DESIGN METHOD B CONTAINED IN SECTION 14 OF THE AASHTO LRFD BRIDGE DESIGN SPECIFICATIONS. FABRICATION SHALL BE IN ACCORDANCE WITH SECTION 18 OF THE AASHTO LRFD BRIDGE CONSTRUCTION SPECIFICATIONS.
- ALL BEARINGS ARE DESIGNED FOR A LOW TEMPERATURE ZONE C AND SHALL HAVE A DUROMETER HARDNESS OF 60. METALLIC REINFORCEMENT SHALL HAVE A MINIMUM YIELD STRENGTH OF 36 KSI.
- BEARING PADS ARE DESIGNED FOR ZERO BRIDGE GRADE. FOR BRIDGE GRADES GREATER THAN 5%, PADS SHALL BE SPECIFICALLY DESIGNED FOR THE GRADE. AS AN ALTERNATE, CAST-IN-PLACE BEVELED SOLE PLATES MAY BE USED.
- DESIGNER, FABRICATOR AND ERECTOR SHALL BE AWARE THAT SKEWED END BEAMS MAY TWIST OR WARP, CAUSING UNEVEN BEAM SEATING AT THE BEARINGS. THE CONTRACTOR IS REQUIRED TO CORRECT AT THE TIME OF ERECTION, BEFORE THE BEAMS ARE SECURED IN PLACE. METHOD OF CORRECTION SHALL PROVIDE AN EVEN, TOTAL BEARING AND A LEVEL TOP BEAM SURFACE. TOLERANCE AFTER CORRECTION SHALL BE + 3/8 INCH. THE FABRICATOR SHALL NOTIFY THE CONTRACTOR AND DESIGNER IF CORRECTIONS ARE REQUIRED PRIOR TO SHIPMENT.
- FOR BEAMS WITH STEPPED ENDS USE PADS A2, B2, OR C2 ON BOTH SIDES OF EACH BEAM.
- ELASTOMERIC BEARING PADS SHALL BE INCLUDED IN THE PRICE OF THE BEAMS.
- THIS SHEET SHALL BE USED IN CONJUNCTION WITH STANDARD SHEETS BR-B17A & B THRU BR-842A & B, BR-8100, BR-8101, BR-8102A, BR-8103, BR-8104, BR-8105A & B AND BR-106 AS APPROPRIATE.

BOX BEAM BEARING PAD CONTROL DIMENSIONS								
PAD	LENGTH	WIDTH	HEIGHT	NO. SHIMS	SHIM SIZE	SPAN RANGES	MAXIMUM REACTION	MAXIMUM MOVEMENT ONE DIRECTION
A1	4 1/2"	28"	1 1/2"	2	1/2" x 4 1/2" x 2" - 3/16"	20' - 38'	55 KIPS	0.39"
B1	4 1/2"	28"	1 1/2"	3	1/2" x 4 1/2" x 2" - 3/16"	40' - 78'	75 KIPS	0.80"
C1	4 1/2"	28"	2 1/2"	2	1/2" x 4 1/2" x 2" - 3/16"	80' - 100'	89 KIPS	1.02"
A2	4 1/2"	15 1/2"	1 1/2"	2	1/2" x 4 1/2" x 1 1/2" - 3/16"	20' - 38'	28 KIPS	0.39"
B2	4 1/2"	15 1/2"	1 1/2"	3	1/2" x 4 1/2" x 1 1/2" - 3/16"	40' - 78'	38 KIPS	0.80"
C2	4 1/2"	15 1/2"	2 1/2"	2	1/2" x 4 1/2" x 1 1/2" - 3/16"	80' - 100'	45 KIPS	1.02"

APPROVED: *[Signature]* DATE: 10-05-07
 DIRECTOR, ENGINEERING DIVISION

WEST VIRGINIA DEPARTMENT OF TRANSPORTATION
 DIVISION OF HIGHWAYS
 ENGINEERING DIVISION

PREPARED: 07-02-07

REVIEWED:

PRESTRESSED CONCRETE BEAM
 ELASTOMERIC BEARING PAD DETAILS
 MISC. DESIGN AND ASSEMBLY DETAILS

STANDARD SHEET BR-8102B

WEST VIRGINIA DEPARTMENT OF TRANSPORTATION
 DIVISION OF HIGHWAYS
 ENGINEERING DIVISION

DESIGNED BY: THB/
 DRAWN BY: THB/
 CHECKED BY: TMJ/
 REVIEWED BY: THB/
 DATE:
 SCALE:
 SHEET OF
 BRIDGE NO.

Right Fork of Mill Creek Bridge
 over
 Right Fork of Mill Creek

PRESTRESSED CONCRETE BEAM
 ELASTOMERIC BEARING PAD DETAILS
 MISC. DESIGN AND ASSEMBLY DETAILS

STATE PROJECT NUMBER	FEDERAL PROJECT NUMBER	STATE DIST. NO.	COUNTY	SHEET NO.	TOTAL SHEETS
S350-362-3.62		02	WAYNE	8	10

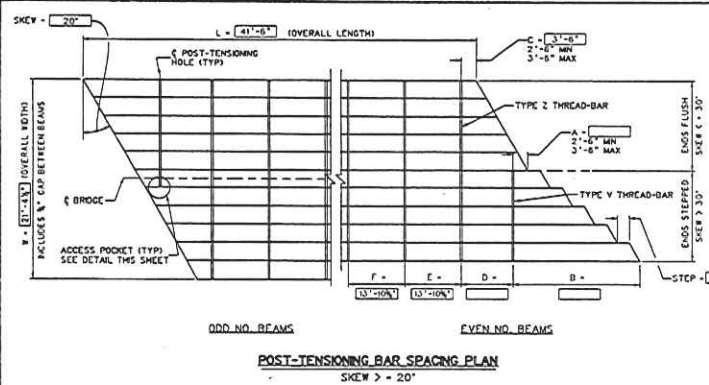

POST-TENSIONING BAR SPACING PLAN
SKEW > 20°

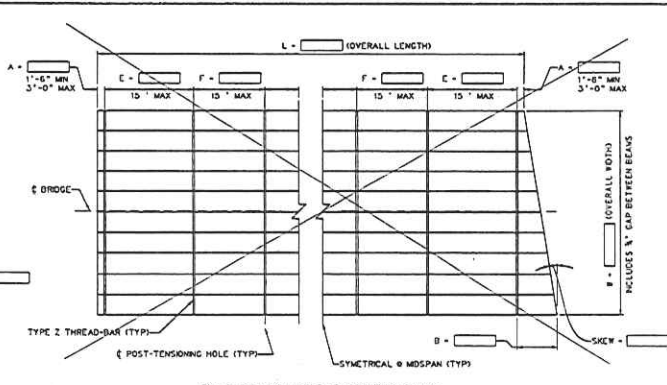

POST-TENSIONING BAR SPACING PLAN
NORMAL OR SKEW < 20°

REFER TO STANDARD SHEET BR-0102A FOR SHEAR KEY DETAILS.

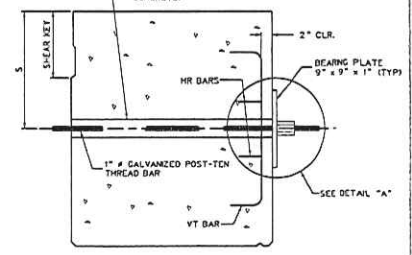

POST-TENSIONING BAR DETAILS

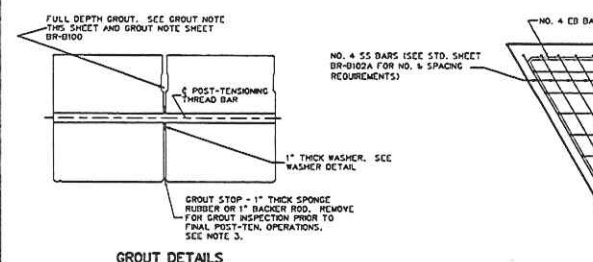

GROUT DETAILS

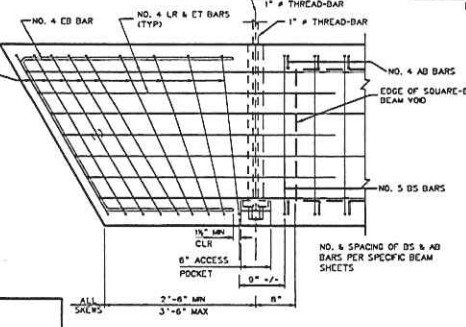

SHEAR REINFORCEMENT DETAIL
BEAMS WITH ACCESS POCKETS

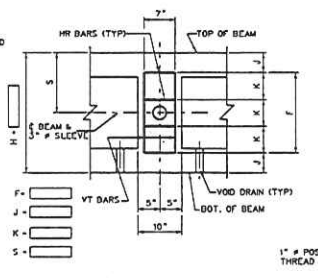

REINFORCING DETAILS @ DIAPHRAGM
EXTERIOR BEAM & POCKETS ONLY

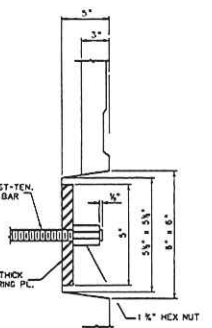

DETAIL "B"

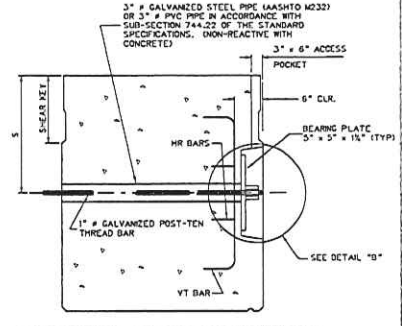

ACCESS POCKET, END POST-TENSIONING BAR

- PROCEDURE NOTES**
- INSTALL ONE INCH THICK WASHER AND GROUT STOP BY GLUING TO ONE SIDE, FOR THE ENTIRE LENGTH OF EACH BEAM PRIOR TO SETTING BEAMS. GLUE SHALL BE AN APPROVED CONSTRUCTION TYPE GLUE OR EPOXY ADHESIVE. GROUT STOP MAY BE INSTALLED AFTER BEAMS ARE SET.
 - GLUE A 3" x 2" x 2" PIECE OF PRESSURE TREATED PLYWOOD AT EACH THREAD-BAR LOCATION TO INSURE THAT A 1/8" GAP IS OBTAINED. PLYWOOD SPACERS TO BE OFFSET APPROXIMATELY 2 FEET FROM THE THREAD-BAR HOLE AND CENTERED ON THE HOLE DEPTH. PLYWOOD SPACERS ARE REQUIRED ON ONLY ONE BEAM EDGE FACE OF ABUTTING BEAMS. AFTER THE BEAMS ARE SET AND THE THREAD-BARS INSTALLED, PULL THE ENTIRE SUPERSTRUCTURE TOGETHER BY APPLYING A POST-TENSIONING FORCE OF APPROXIMATELY 3000 POUNDS. AT THIS STAGE THE GAP BETWEEN BEAMS SHALL BE A UNIFORM 1/8" WITH ALL SWEEP REMOVED. RECORD THE ACTUAL FORCE APPLIED.
 - FILL THE GAP BETWEEN BEAMS AND SHEAR KEY FULL DEPTH WITH THE PRE-APPROVED, PRE-TESTED GROUT MIXTURE. FROM EACH BATCH, PREPARE JOB CONTROL GROUT CURES FOR THREE AND SEVEN DAY TESTS. THESE JOB CONTROL SAMPLES WILL BE USED TO DETERMINE WHEN THE GROUT HAS ATTAINED A MINIMUM COMPRESSIVE STRENGTH OF 4500 PSI. A MINIMUM OF THREE SPECIMENS PER TEST SHALL BE OBTAINED, AND THE AVERAGE OF THE TEST RESULTS USED. ACCEPTANCE SAMPLING AND TESTING OF THE GROUT IS THE RESPONSIBILITY OF THE CONTRACTOR; HOWEVER, A REPRESENTATIVE OF THE WYDOT SHALL WITNESS ALL OF THE ACCEPTANCE SAMPLING AND TESTING.

TEST PROCEDURE SHALL BE ASTM C109 AS MODIFIED BY ASTM C1107. IN NO INSTANCE SHALL THE CONTRACTOR PROCEED WITH POST-TENSIONING OR OTHER BEAM ERECTION PROCEDURES UNTIL THE REQUIRED MINIMUM GROUT STRENGTH IS ATTAINED AND VERIFIED BY THE ENGINEER. IN THE EVENT THAT THE MINIMUM GROUT STRENGTH IS NOT ATTAINED, THE ENGINEER SHALL BE NOTIFIED AND CORRECTIVE ACTION TAKEN AT THE DIRECTION OF THE ENGINEER. SEE SHEAR KEY GROUT NOTE, SHEET BR-0100 FOR ADDITIONAL REQUIREMENTS.

AFTER THE GROUT HAS REACHED AN INITIAL SET CONDITION AND PRIOR TO ANY FINAL POST-TENSIONING PROCEDURES, THE CONTRACTOR SHALL REMOVE THE GROUT STOP AND INSPECT THE GROUT FOR VOIDS OR OTHER IRREGULARITIES. ANY VOIDS DEEPER THAN 2" FROM THE BOTTOM SHALL BE REGROUTED IN A MANNER ACCEPTABLE TO THE ENGINEER.
 - AFTER GROUT HAS BEEN PLACED AND REACHED ITS MINIMUM COMPRESSIVE STRENGTH OF 4500 PSI AND HAS CURED A MINIMUM OF 3 DAYS, APPLY 50% OF THE FINAL POST-TENSIONING FORCE TO ALL THREAD-BARS, WITHIN BEAM ENDS TO MSPAN. AFTER ALL THREAD-BARS HAVE BEEN TENSIONED TO 50%, APPLY THE REMAINING PERCENTAGE OF FINAL POST-TENSIONING FORCE, WORKING IN THE SAME SEQUENCE AS THE FIRST STAGE OF FINAL TENSIONING.
 - MEASURE AND RECORD, IN THE ELONGATION TABLE, THIS SHEET, THE ACTUAL TOTAL ELONGATION OF EACH THREAD-BAR. COMPARE THE MEASURED ELONGATION TO THE CALCULATED ELONGATION. A SIGNIFICANT DIFFERENCE BETWEEN MEASURED AND CALCULATED ELONGATIONS COULD INDICATE BARPROPER JACING TECHNIQUES, FAULTY MATERIALS, FAULTY JACKS, OR IMPROPERLY CALIBRATED JACKS. IF THE DIFFERENCE IS GREATER THAN 15%, THEN THE JACKS SHALL BE RE-CALIBRATED AND THE JACING TECHNIQUES EVALUATED. IF, AFTER THE ABOVE STEPS ARE TAKEN, THE PERCENTAGE DIFFERENCE IS GREATER THAN 10%, THEN THE ENGINEER SHALL BE NOTIFIED AND CORRECTIVE ACTION TAKEN AT THE DIRECTION OF THE ENGINEER. ALL COSTS INVOLVED IN CORRECTION SHALL BE AT THE CONTRACTOR'S EXPENSE.
 - USING SAW, TRIM EXCESS THREAD-BAR LEAVING 4" TO 6" PAST THE NUT. DO NOT TRIM THREAD-BARS BY TORCH CUTTING. TOUCH-UP FRAMED ENDS WITH GALVANIZED OR COAL.
 - INSTALL ANCHOR BOWELS AS DETAILED ON STANDARD SHEETS BR-0101 AND BR-0102A.

FINAL POST-TENSIONING FORCE
TYPE 2 BARS = 80 KIPS
TYPE V BARS = 40 KIPS

SPAN	40'-0"
SKEW	20° LFS
L	41'-0"
W	21'-4 1/2"
A	
B	
C	3'-8"
D	
E	13'-10 1/2"
F	13'-10 1/2"
STEP	

BEAM SIZE	REINFORCEMENT DIM	BAR SPACING	BAR DIST
	IN.	IN.	IN.
H	F	J	K
17	12	2 1/2	4
21	12	4 1/2	4
27	18	4 1/2	6
33	24	4 1/2	8
39	30	4 1/2	10
42	33	4 1/2	11

	3 DAY (PSI)	7 DAY (PSI)
PRE-TEST STRENGTH		
JOB CONTROL STRENGTH		
GROUT TYPE & MANUFACTURER		

BAR	FORMULA	LENGTH
V(EVEN)	3/2	
Z	W/2	
V(ODD)	W/4 + 6"	

BAR	CODE	CALC.	MEASURED								
			NO. 1	NO. 2	NO. 3	NO. 4	NO. 5	NO. 6	NO. 7	NO. 8	
Z	(O)										
V	(O)										

CALCULATED (O) = WFT.J / 24.8 500 NO. BEAMS CALCULATED (O) = WFT.J - 31 / 99.2
 CALCULATED (O) = WFT.J / 99.2

- SPECIAL FINISHING NOTES**
- DO NOT STAND IN LINE WITH THE POST-TENSIONING BAR DURING TENSIONING PROCEDURES.
 - NUTS, COUPLERS AND EXTENSION ROOFS USED IN THE POST-TENSIONING WORK SHALL BE THE MATERIAL APPROVED BY THE MANUFACTURER OF THE HIGH STRENGTH POST-TENSIONING ROOFS. IN NO CASE SHALL THE CONTRACTOR USE NON-APPROVED MATERIAL OR MATERIAL FROM TWO DIFFERENT SOURCES.

WEST VIRGINIA DEPARTMENT OF TRANSPORTATION
DIVISION OF HIGHWAYS
ENGINEERING DIVISION

PREPARED: 07-02-07

PRESTRESSED CONCRETE BEAM
TRANSVERSE POST-TENSIONING DETAILS
STANDARD SHEET BR-0103

WEST VIRGINIA DEPARTMENT OF TRANSPORTATION
DIVISION OF HIGHWAYS
ENGINEERING DIVISION

Right Fork of Mill Creek Bridge
OVER
Right Fork of Mill Creek

DESIGNED BY THW
DRAWN BY THW
CHECKED BY THW
REVIEWED BY THW

DATE: _____
SCALE: _____
SHEET NO. OF _____
BRIDGE NUMBER _____

PRESTRESSED CONCRETE BEAM
TRANSVERSE POST-TENSIONING DETAILS

STATE PROJECT NUMBER	FEDERAL PROJECT NUMBER	SIGNAL DIST. NO.	COUNTY	SHEET NO.	TOTAL SHEETS
S350-382-3.62		02	WAYNE	9	10

BRIDGE APPROACH GUARDRAIL
SEE SHEETS GRI THRU GRII,
STANDARD DETAILS BOOK
(SUPPLIED BY OTHERS)

NOTE TO BEAM FABRICATOR: REFER TO BR-8101
FOR SUPPLY AND INSTALLATION REQUIREMENTS

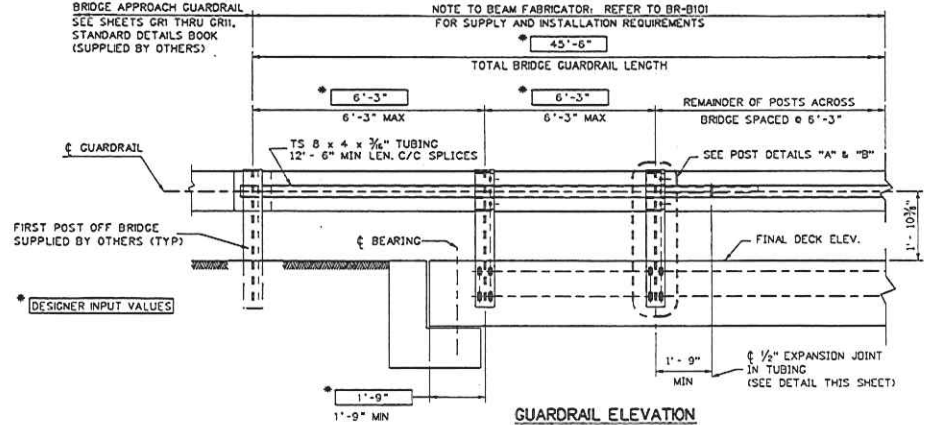

GUARDRAIL ELEVATION

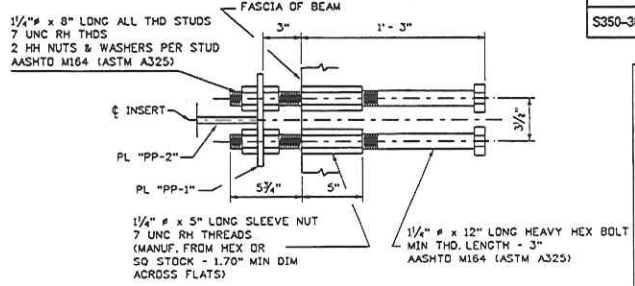

TYPE '1A' ANCHOR DETAIL

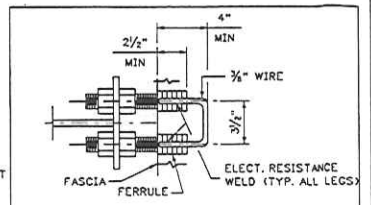

SECTION A-A

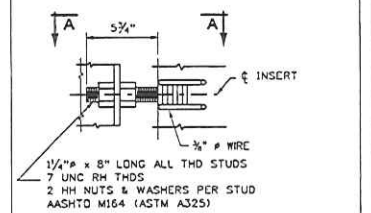

TYPE '2A' ANCHOR DETAIL

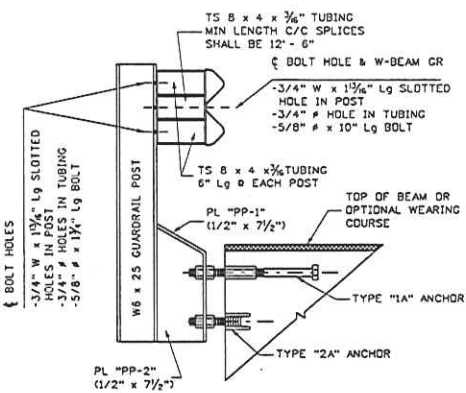

GUARDRAIL POST DETAIL 'A'

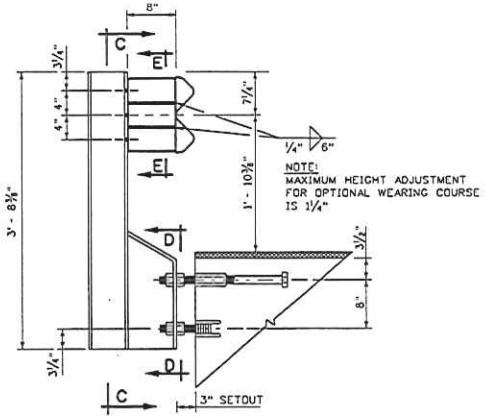

GUARDRAIL POST DETAIL 'B'

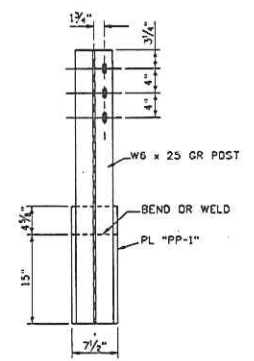

SECTION C-C

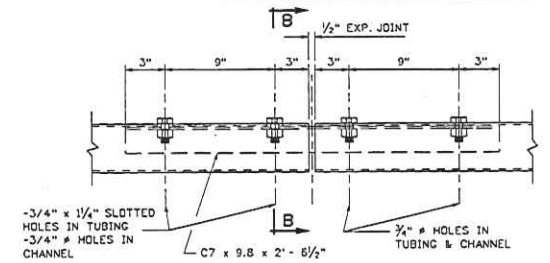

TUBING SPLICE/EXPANSION JOINT DETAIL

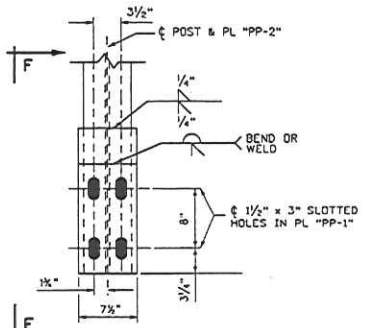

SECTION D-D

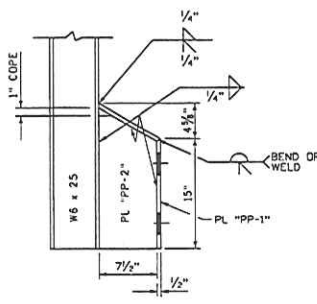

SECTION F-F

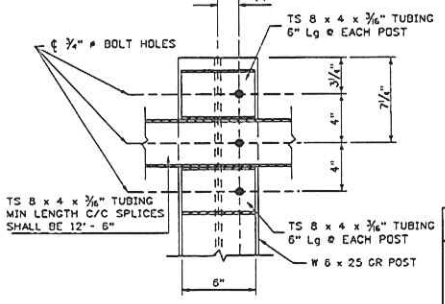

SECTION E-E

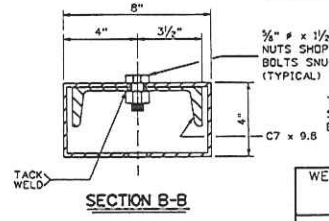

SECTION B-B

THIS SHEET SHALL BE USED IN CONJUNCTION WITH STANDARD SHEETS BR-817A & B THRU BR-842A & B, BR-8100, BR-8101, BR-8102A & B, AND BR-8103 AS APPLICABLE.

APPROVED: *[Signature]*
WEST VIRGINIA DEPARTMENT OF TRANSPORTATION
DIVISION OF HIGHWAYS
ENGINEERING DIVISION
PRESTRESSED CONCRETE BEAM
TYPE TL-2 GUARDRAIL SYSTEM
DESIGN & ASSEMBLY DETAILS
STANDARD SHEET BR-8104

WEST VIRGINIA DEPARTMENT OF TRANSPORTATION
DIVISION OF HIGHWAYS
ENGINEERING DIVISION
Right Fork of Mill Creek Bridge
over
Right Fork of Mill Creek
PRESTRESSED CONCRETE BEAM
TYPE TL-2 GUARDRAIL SYSTEM
DESIGN & ASSEMBLY DETAILS

DESIGNED BY: THW
DRAWN BY: THW
CHECKED BY: THW
DATE:
SCALE:
SHEET NO. OF:
BRIDGE NUMBER:

PROJECT NUMBERS		DISTRICT	COUNTY	SHEET NO.	TOTAL
STATE	FEDERAL				
5358-362-3.02		02	WAYNE	10	10

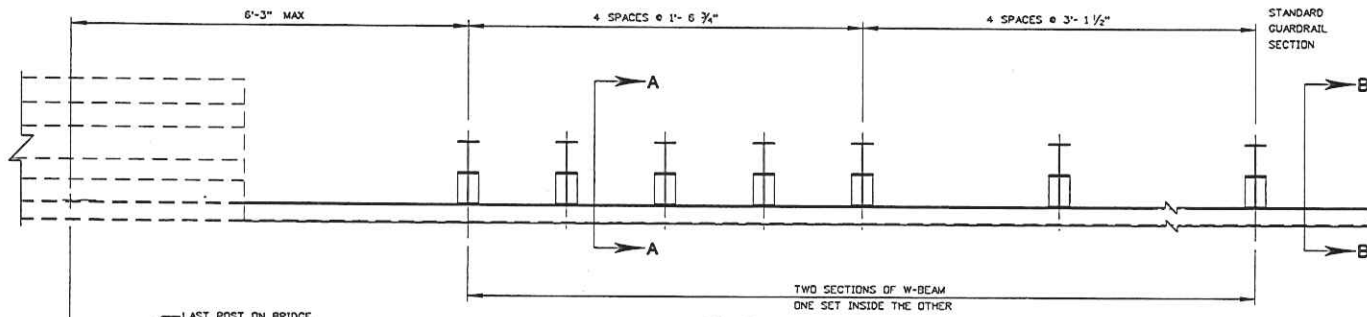

NOTES

1. THIS GUARDRAIL TRANSITION IS APPROPRIATE FOR CONNECTION TO GUARDRAIL ON BRIDGE.
2. W-BEAM IS NOT BOLTED TO POSTS AT POSTS 2 THROUGH 4 AND POST 6.
3. SEE STANDARD SHEET BR-B104 FOR ANCHOR DETAILS.
4. THERE IS NO SEPARATE PAY ITEM FOR THIS CONNECTION AND ALL COMPONENTS AS DETAILED HEREIN SHALL BE INCLUDED IN THE CONTRACT PRICE FOR GUARDRAIL.

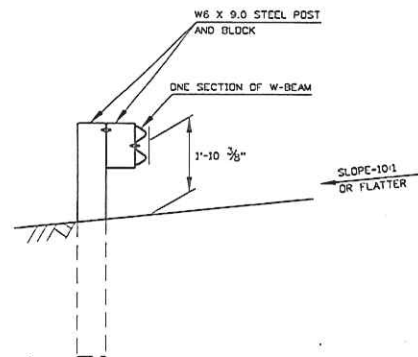
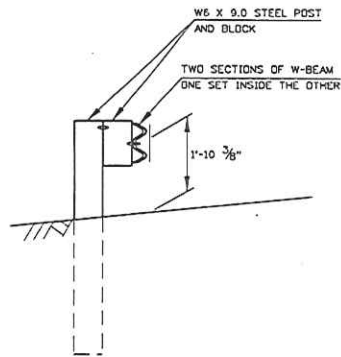
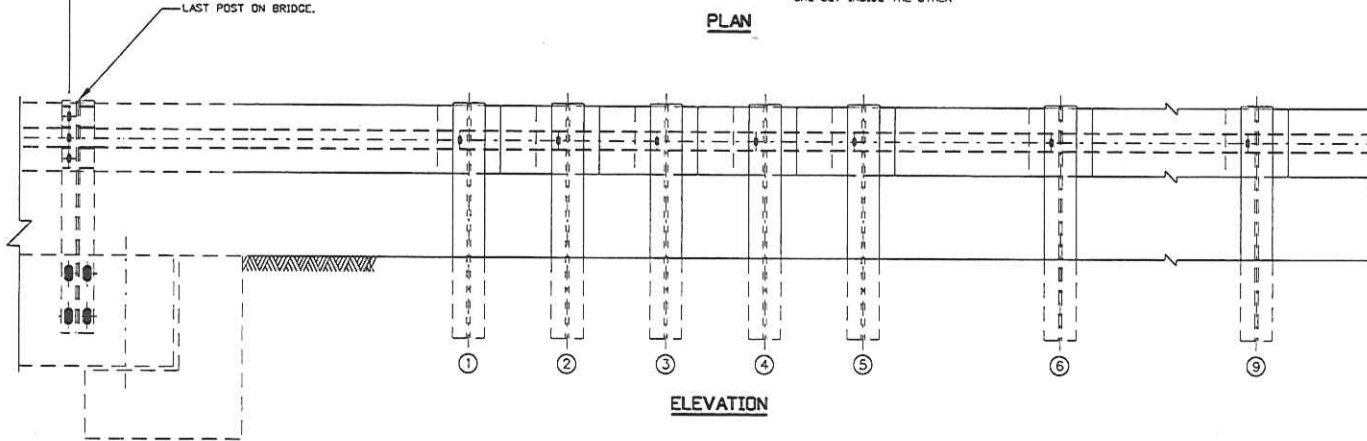

THIS SHEET SHALL BE USED IN CONJUNCTION WITH STANDARD SHEETS BR-B17A & B THRU BR-B42A & B, BR-B100, BR-B101, BR-B102A & B, BR-B103 AND BR-B104 AS APPLICABLE.

WEST VIRGINIA DEPARTMENT OF TRANSPORTATION DIVISION OF HIGHWAYS ENGINEERING DIVISION		DESIGNED BY:TW/
Right Fork of Mill Creek Bridge over Right Fork of Mill Creek		DRAWN BY:BH/
		CHECKED BY:TW/
TYPE TL-2 GUARDRAIL TRANSITION		REVIEWED BY:THB/
		DATE:
		SCALE:
		SHEET OF
		BRIDGE NO.

APPROVED: *Dianna Baily* DATE: 07-25-07

DIRECTOR, ENGINEERING DIVISION

WEST VIRGINIA DEPARTMENT OF TRANSPORTATION
DIVISION OF HIGHWAYS
ENGINEERING DIVISION

PREPARED: 07-02-07

REVISIONS:

PRESTRESSED CONCRETE BEAM
TYPE TL-2 GUARDRAIL SYSTEMS
DESIGN & ASSEMBLY DETAILS

STANDARD SHEET BR-B106

VENDOR PREFERENCE CERTIFICATE

Certification and application* is hereby made for Preference in accordance with *West Virginia Code*, §5A-3-37. (Does not apply to construction contracts). *West Virginia Code*, §5A-3-37, provides an opportunity for qualifying vendors to request (at the time of bid) preference for their residency status. Such preference is an evaluation method only and will be applied only to the cost bid in accordance with the *West Virginia Code*. This certificate for application is to be used to request such preference. The Purchasing Division will make the determination of the Resident Vendor Preference, if applicable.

1. Application is made for 2.5% resident vendor preference for the reason checked:

Bidder is an individual resident vendor and has resided continuously in West Virginia for four (4) years immediately preceding the date of this certification; **or**,

Bidder is a partnership, association or corporation resident vendor and has maintained its headquarters or principal place of business continuously in West Virginia for four (4) years immediately preceding the date of this certification; or 80% of the ownership interest of Bidder is held by another individual, partnership, association or corporation resident vendor who has maintained its headquarters or principal place of business continuously in West Virginia for four (4) years immediately preceding the date of this certification; **or**,

Bidder is a nonresident vendor which has an affiliate or subsidiary which employs a minimum of one hundred state residents and which has maintained its headquarters or principal place of business within West Virginia continuously for the four (4) years immediately preceding the date of this certification; **or**,

2. Application is made for 2.5% resident vendor preference for the reason checked:

Bidder is a resident vendor who certifies that, during the life of the contract, on average at least 75% of the employees working on the project being bid are residents of West Virginia who have resided in the state continuously for the two years immediately preceding submission of this bid; **or**,

3. Application is made for 2.5% resident vendor preference for the reason checked:

Bidder is a nonresident vendor employing a minimum of one hundred state residents or is a nonresident vendor with an affiliate or subsidiary which maintains its headquarters or principal place of business within West Virginia employing a minimum of one hundred state residents who certifies that, during the life of the contract, on average at least 75% of the employees or Bidder's affiliate's or subsidiary's employees are residents of West Virginia who have resided in the state continuously for the two years immediately preceding submission of this bid; **or**,

4. Application is made for 5% resident vendor preference for the reason checked:

Bidder meets either the requirement of both subdivisions (1) and (2) or subdivision (1) and (3) as stated above; **or**,

5. Application is made for 3.5% resident vendor preference who is a veteran for the reason checked:

Bidder is an individual resident vendor who is a veteran of the United States armed forces, the reserves or the National Guard and has resided in West Virginia continuously for the four years immediately preceding the date on which the bid is submitted; **or**,

6. Application is made for 3.5% resident vendor preference who is a veteran for the reason checked:

Bidder is a resident vendor who is a veteran of the United States armed forces, the reserves or the National Guard, if, for purposes of producing or distributing the commodities or completing the project which is the subject of the vendor's bid and continuously over the entire term of the project, on average at least seventy-five percent of the vendor's employees are residents of West Virginia who have resided in the state continuously for the two immediately preceding years.

Bidder understands if the Secretary of Revenue determines that a Bidder receiving preference has failed to continue to meet the requirements for such preference, the Secretary may order the Director of Purchasing to: (a) reject the bid; or (b) assess a penalty against such Bidder in an amount not to exceed 5% of the bid amount and that such penalty will be paid to the contracting agency or deducted from any unpaid balance on the contract or purchase order.

By submission of this certificate, Bidder agrees to disclose any reasonably requested information to the Purchasing Division and authorizes the Department of Revenue to disclose to the Director of Purchasing appropriate information verifying that Bidder has paid the required business taxes, provided that such information does not contain the amounts of taxes paid nor any other information deemed by the Tax Commissioner to be confidential.

Under penalty of law for false swearing (West Virginia Code, §61-5-3), Bidder hereby certifies that this certificate is true and accurate in all respects; and that if a contract is issued to Bidder and if anything contained within this certificate changes during the term of the contract, Bidder will notify the Purchasing Division in writing immediately.

Bidder: _____ Signed: _____

Date: _____ Title: _____

*Check any combination of preference consideration(s) indicated above, which you are entitled to receive.

STATE OF WEST VIRGINIA
Purchasing Division

PURCHASING AFFIDAVIT

West Virginia Code §5A-3-10a states: No contract or renewal of any contract may be awarded by the state or any of its political subdivisions to any vendor or prospective vendor when the vendor or prospective vendor or a related party to the vendor or prospective vendor is a debtor and the debt owed is an amount greater than one thousand dollars in the aggregate.

DEFINITIONS:

"Debt" means any assessment, premium, penalty, fine, tax or other amount of money owed to the state or any of its political subdivisions because of a judgment, fine, permit violation, license assessment, defaulted workers' compensation premium, penalty or other assessment presently delinquent or due and required to be paid to the state or any of its political subdivisions, including any interest or additional penalties accrued thereon.

"Debtor" means any individual, corporation, partnership, association, limited liability company or any other form or business association owing a debt to the state or any of its political subdivisions. "Political subdivision" means any county commission; municipality; county board of education; any instrumentality established by a county or municipality; any separate corporation or instrumentality established by one or more counties or municipalities, as permitted by law; or any public body charged by law with the performance of a government function or whose jurisdiction is coextensive with one or more counties or municipalities. "Related party" means a party, whether an individual, corporation, partnership, association, limited liability company or any other form or business association or other entity whatsoever, related to any vendor by blood, marriage, ownership or contract through which the party has a relationship of ownership or other interest with the vendor so that the party will actually or by effect receive or control a portion of the benefit, profit or other consideration from performance of a vendor contract with the party receiving an amount that meets or exceed five percent of the total contract amount.

EXCEPTION: The prohibition of this section does not apply where a vendor has contested any tax administered pursuant to chapter eleven of this code, workers' compensation premium, permit fee or environmental fee or assessment and the matter has not become final or where the vendor has entered into a payment plan or agreement and the vendor is not in default of any of the provisions of such plan or agreement.

Under penalty of law for false swearing (*West Virginia Code* §61-5-3), it is hereby certified that the vendor affirms and acknowledges the information in this affidavit and is in compliance with the requirements as stated.

WITNESS THE FOLLOWING SIGNATURE

Vendor's Name: _____

Authorized Signature: _____ Date: _____

State of _____

County of _____, to-wit:

Taken, subscribed, and sworn to before me this ____ day of _____, 20__.

My Commission expires _____, 20__.

AFFIX SEAL HERE

NOTARY PUBLIC _____

Please use this document for technical questions, posing in a question format

Please refer to the section your question is in reference to.

Technical questions for RFQ# _____

Vendor Name: _____

Questions:
