



State of West Virginia  
 Department of Administration  
 Purchasing Division  
 2019 Washington Street East  
 Post Office Box 50130  
 Charleston, WV 25305-0130

# Request for Quotation

RFQ NUMBER  
 DNRB11166

PAGE  
 1

ADDRESS CORRESPONDENCE TO ATTENTION OF  
 FRANK WHITTAKER  
 304-558-2316

RFQ COPY  
 TYPE NAME/ADDRESS HERE

V  
E  
N  
D  
O  
R

S  
H  
I  
P  
T  
O

DIVISION OF NATURAL RESOURCES  
 VARIOUS LOCALES AS INDICATED  
 BY ORDER

DATE PRINTED	TERMS OF SALE	SHIP VIA	F.O.B	FREIGHT TERMS
04/13/2011				

BID OPENING DATE: 05/24/2011 BID OPENING TIME 01:30PM

LINE	QUANTITY	UOP	CAT NO	ITEM NUMBER	UNIT PRICE	AMOUNT
0001	1	LS		420-40		
HOUSEHOLD FURNITURE, GENERAL LINE						
<p>THE WEST VIRGINIA PURCHASING DIVISION FOR THE AGENCY, THE WEST VIRGINIA DIVISION OF NATURAL RESOURCES IS SOLICITING BIDS FROM RESPONSIBLE VENDORS FOR AN OPEN-END CONTRACT TO PROVIDE THE AGENCY WITH GUEST ROOM AND LOBBY FURNITURE PER THE ATTACHED SPECIFICATIONS.</p> <p>ALL TECHNICAL QUESTIONS MUST BE SUBMITTED IN WRITING TO FRANK WHITTAKER IN THE WV PURCHASING DIVISION VIA EMAIL AT FRANK.M.WHITTAKER@WV.GOV OR VIA FAX AT 304-558-4115. DEADLINE FOR ALL TECHNICAL QUESTIONS IS 04/27/2011 AT 4:00 PM. ALL TECHNICAL WILL BE ADDRESSED BY ADDENDUM AFTER THE DEADLINE.</p> <p>EXHIBIT 2</p> <p>LIFE OF CONTRACT: THIS CONTRACT BECOMES EFFECTIVE ON ..... AND EXTENDS FOR A PERIOD OF ONE (1) YEAR OR UNTIL SUCH "REASONABLE TIME" THEREAFTER AS IS NECESSARY TO OBTAIN A NEW CONTRACT OR RENEW THE ORIGINAL CONTRACT. THE "REASONABLE TIME" PERIOD SHALL NOT EXCEED TWELVE (12) MONTHS. DURING THIS "REASONABLE TIME" THE VENDOR MAY TERMINATE THIS CONTRACT FOR ANY REASON UPON GIVING THE DIRECTOR OF PURCHASING THIRTY (30) DAYS WRITTEN NOTICE.</p> <p>UNLESS SPECIFIC PROVISIONS ARE STIPULATED IN THIS CONTRACT DOCUMENT, THE TERMS, CONDITIONS, AND PRICING</p>						
SEE REVERSE SIDE FOR TERMS AND CONDITIONS						

SIGNATURE		TELEPHONE		DATE
TITLE	FEIN	ADDRESS CHANGES TO BE NOTED ABOVE		

WHEN RESPONDING TO RFQ, INSERT NAME AND ADDRESS IN SPACE ABOVE LABELED 'VENDOR'

**GENERAL TERMS & CONDITIONS**  
**REQUEST FOR QUOTATION (RFQ) AND REQUEST FOR PROPOSAL (RFP)**

1. Awards will be made in the best interest of the State of West Virginia.
2. The State may accept or reject in part, or in whole, any bid.
3. Prior to any award, the apparent successful vendor must be properly registered with the Purchasing Division and have paid the required \$125 fee.
4. All services performed or goods delivered under State Purchase Order/Contracts are to be continued for the term of the Purchase Order/Contracts, contingent upon funds being appropriated by the Legislature or otherwise being made available. In the event funds are not appropriated or otherwise available for these services or goods this Purchase Order/Contract becomes void and of no effect after June 30.
5. Payment may only be made after the delivery and acceptance of goods or services.
6. Interest may be paid for late payment in accordance with the *West Virginia Code*.
7. Vendor preference will be granted upon written request in accordance with the *West Virginia Code*.
8. The State of West Virginia is exempt from federal and state taxes and will not pay or reimburse such taxes.
9. The Director of Purchasing may cancel any Purchase Order/Contract upon 30 days written notice to the seller.
10. The laws of the State of West Virginia and the *Legislative Rules* of the Purchasing Division shall govern the purchasing process.
11. Any reference to automatic renewal is hereby deleted. The Contract may be renewed only upon mutual written agreement of the parties.
12. **BANKRUPTCY:** In the event the vendor/contractor files for bankruptcy protection, the State may deem this contract null and void, and terminate such contract without further order.
13. **HIPAA BUSINESS ASSOCIATE ADDENDUM:** The West Virginia State Government HIPAA Business Associate Addendum (BAA), approved by the Attorney General, is available online at [www.state.wv.us/admin/purchase/vrc/hipaa.htm](http://www.state.wv.us/admin/purchase/vrc/hipaa.htm) and is hereby made part of the agreement. Provided that the Agency meets the definition of a Cover Entity (45 CFR §160.103) and will be disclosing Protected Health Information (45 CFR §160.103) to the vendor.
14. **CONFIDENTIALITY:** The vendor agrees that he or she will not disclose to anyone, directly or indirectly, any such personally identifiable information or other confidential information gained from the agency, unless the individual who is the subject of the information consents to the disclosure in writing or the disclosure is made pursuant to the agency's policies, procedures, and rules. Vendor further agrees to comply with the Confidentiality Policies and Information Security Accountability Requirements, set forth in <http://www.state.wv.us/admin/purchase/privacy/noticeConfidentiality.pdf>.
15. **LICENSING:** Vendors must be licensed and in good standing in accordance with any and all state and local laws and requirements by any state or local agency of West Virginia, including, but not limited to, the West Virginia Secretary of State's Office, the West Virginia Tax Department, and the West Virginia Insurance Commission. The vendor must provide all necessary releases to obtain information to enable the director or spending unit to verify that the vendor is licensed and in good standing with the above entities.
16. **ANTITRUST:** In submitting a bid to any agency for the State of West Virginia, the bidder offers and agrees that if the bid is accepted the bidder will convey, sell, assign or transfer to the State of West Virginia all rights, title and interest in and to all causes of action it may now or hereafter acquire under the antitrust laws of the United States and the State of West Virginia for price fixing and/or unreasonable restraints of trade relating to the particular commodities or services purchased or acquired by the State of West Virginia. Such assignment shall be made and become effective at the time the purchasing agency tenders the initial payment to the bidder.

I certify that this bid is made without prior understanding, agreement, or connection with any corporation, firm, limited liability company, partnership, or person or entity submitting a bid for the same material, supplies, equipment or services and is in all respects fair and without collusion or Fraud. I further certify that I am authorized to sign the certification on behalf of the bidder or this bid.

**INSTRUCTIONS TO BIDDERS**

1. Use the quotation forms provided by the Purchasing Division. Complete all sections of the quotation form.
2. Items offered must be in compliance with the specifications. Any deviation from the specifications must be clearly indicated by the bidder. Alternates offered by the bidder as **EQUAL** to the specifications must be clearly defined. A bidder offering an alternate should attach complete specifications and literature to the bid. The Purchasing Division may waive minor deviations to specifications.
3. Unit prices shall prevail in case of discrepancy. All quotations are considered F.O.B. destination unless alternate shipping terms are clearly identified in the quotation.
4. All quotations must be delivered by the bidder to the office listed below prior to the date and time of the bid opening. Failure of the bidder to deliver the quotations on time will result in bid disqualifications: Department of Administration, Purchasing Division, 2019 Washington Street East, P.O. Box 50130, Charleston, WV 25305-0130
5. Communication during the solicitation, bid, evaluation or award periods, except through the Purchasing Division, is strictly prohibited (W.Va. C.S.R. §148-1-6.6).



State of West Virginia  
 Department of Administration  
 Purchasing Division  
 2019 Washington Street East  
 Post Office Box 50130  
 Charleston, WV 25305-0130

# Request for Quotation

RFQ NUMBER  
 DNRB11166

PAGE  
 2

ADDRESS CORRESPONDENCE TO ATTENTION OF  
 FRANK WHITTAKER  
 304-558-2316

RFQ COPY

TYPE NAME/ADDRESS HERE

VENDOR

SHIP TO

DIVISION OF NATURAL RESOURCES  
 VARIOUS LOCALES AS INDICATED  
 BY ORDER

DATE PRINTED	TERMS OF SALE	SHIP VIA	F.O.B.	FREIGHT TERMS
04/13/2011				

BID OPENING DATE: 05/24/2011 BID OPENING TIME 01:30PM

LINE	QUANTITY	UOP	CAT NO	ITEM NUMBER	UNIT PRICE	AMOUNT
<p>SET HEREIN ARE FIRM FOR THE LIFE OF THE CONTRACT.</p> <p>RENEWAL: THIS CONTRACT MAY BE RENEWED UPON THE MUTUAL WRITTEN CONSENT OF THE SPENDING UNIT AND VENDOR, SUBMITTED TO THE DIRECTOR OF PURCHASING THIRTY (30) DAYS PRIOR TO THE EXPIRATION DATE. SUCH RENEWAL SHALL BE IN ACCORDANCE WITH THE TERMS AND CONDITIONS OF THE ORIGINAL CONTRACT AND SHALL BE LIMITED TO TWO (2) ONE (1) YEAR PERIODS.</p> <p>CANCELLATION: THE DIRECTOR OF PURCHASING RESERVES THE RIGHT TO CANCEL THIS CONTRACT IMMEDIATELY UPON WRITTEN NOTICE TO THE VENDOR IF THE COMMODITIES AND/OR SERVICES SUPPLIED ARE OF AN INFERIOR QUALITY OR DO NOT CONFORM WITH THE SPECIFICATIONS OF THE BID AND CONTRACT HEREIN.</p> <p>OPEN MARKET CLAUSE: THE DIRECTOR OF PURCHASING MAY AUTHORIZE A SPENDING UNIT TO PURCHASE ON THE OPEN MARKET, WITHOUT THE FILING OF A REQUISITION OR COST ESTIMATE, ITEMS SPECIFIED ON THIS CONTRACT FOR IMMEDIATE DELIVERY IN EMERGENCIES DUE TO UNFORESEEN CAUSES (INCLUDING BUT NOT LIMITED TO DELAYS IN TRANSPORTATION OR AN UNANTICIPATED INCREASE IN THE VOLUME OF WORK).</p> <p>QUANTITIES: QUANTITIES LISTED IN THE REQUISITION ARE APPROXIMATIONS ONLY, BASED ON ESTIMATES SUPPLIES BY THE STATE SPENDING UNIT. IT IS UNDERSTOOD AND AGREED THAT THE CONTRACT SHALL COVER THE QUANTITIES ACTUALLY ORDERED FOR DELIVERY DURING THE TERM OF CONTRACT, WHETHER MORE OR LESS THAN THE QUANTITIES SHOWN.</p> <p>ORDERING PROCEDURE: SPENDING UNIT(S) SHALL ISSUE A WRITTEN EQUIPMENT CONTRACT ORDER (FORM NUMBER WV-35) FOR COMMODITIES COVERED BY THIS CONTRACT. THE ORIGINAL WV-35 MUST BE SENT TO THE PURCHASING DIVISION OF THE DEPARTMENT OF ADMINISTRATION. AFTER APPROVAL</p>						

SEE REVERSE SIDE FOR TERMS AND CONDITIONS

SIGNATURE	TELEPHONE	DATE
TITLE	FEIN	ADDRESS CHANGES TO BE NOTED ABOVE

WHEN RESPONDING TO RFQ, INSERT NAME AND ADDRESS IN SPACE ABOVE LABELED 'VENDOR'



State of West Virginia  
 Department of Administration  
 Purchasing Division  
 2019 Washington Street East  
 Post Office Box 50130  
 Charleston, WV 25305-0130

# Request for Quotation

RFQ NUMBER  
 DNRB11166

PAGE  
 3

ADDRESS CORRESPONDENCE TO ATTENTION OF  
 FRANK WHITTAKER  
 304-558-2316

RFQ COPY  
 TYPE NAME/ADDRESS HERE

VENDOR

SHIP TO

DIVISION OF NATURAL RESOURCES  
 VARIOUS LOCALES AS INDICATED  
 BY ORDER

DATE PRINTED	TERMS OF SALE	SHIP VIA	F.O.B.	FREIGHT TERMS
04/13/2011				

BID OPENING DATE: 05/24/2011 BID OPENING TIME 01:30PM

LINE	QUANTITY	UOP	CAT NO	ITEM NUMBER	UNIT PRICE	AMOUNT
<p>AND ENCUMBRANCE, ONE COPY OF THE PURCHASE ORDER WILL BE RETURNED TO THE SPENDING UNIT AND ONE COPY FORWARDED TO THE VENDOR AS AUTHORIZATION FOR SHIPMENT. NO ORDER IS VALID UNLESS APPROVED AND ENCUMBERED BY THE PURCHASING DIVISION.</p> <p>BANKRUPTCY: IN THE EVENT THE VENDOR/CONTRACTOR FILES FOR BANKRUPTCY PROTECTION, THE STATE MAY DEEM THE CONTRACT NULL AND VOID, AND TERMINATE SUCH CONTRACT WITHOUT FUTHER ORDER.</p> <p>REV. 5/2009</p> <p>EXHIBIT 4</p> <p>LOCAL GOVERNMENT BODIES: UNLESS THE VENDOR INDICATES IN THE BID HIS REFUSAL TO EXTEND THE PRICES, TERMS, AND CONDITIONS OF THE BID TO COUNTY, SCHOOL, MUNICIPAL AND OTHER LOCAL GOVERNMENT BODIES, THE BID SHALL EXTEND TO POLITICAL SUBDIVISIONS OF THE STATE OF WEST VIRGINIA. IF THE VENDOR DOES NOT WISH TO EXTEND THE PRICES, TERMS, AND CONDITIONS OF THE BID TO ALL POLITICAL SUBDIVISIONS OF THE STATE, THE VENDOR MUST CLEARLY INDICATE SUCH REFUSAL IN HIS BID. SUCH REFUSAL SHALL NOT PREJUDICE THE AWARD OF THIS CONTRACT IN ANY MANNER.</p> <p>REV. 3/88</p> <p style="text-align: center;">NOTICE</p> <p>A SIGNED BID MUST BE SUBMITTED TO:</p> <p style="text-align: center;">DEPARTMENT OF ADMINISTRATION PURCHASING DIVISION</p>						

SEE REVERSE SIDE FOR TERMS AND CONDITIONS

SIGNATURE	TELEPHONE	DATE
TITLE	FEIN	ADDRESS CHANGES TO BE NOTED ABOVE

WHEN RESPONDING TO RFQ, INSERT NAME AND ADDRESS IN SPACE ABOVE LABELED 'VENDOR'



State of West Virginia  
 Department of Administration  
 Purchasing Division  
 2019 Washington Street East  
 Post Office Box 50130  
 Charleston, WV 25305-0130

# Request for Quotation

RFQ NUMBER  
**DNRB11166**

PAGE  
**4**

ADDRESS CORRESPONDENCE TO ATTENTION OF  
**FRANK WHITTAKER**  
**304-558-2316**

RFQ COPY

TYPE NAME/ADDRESS HERE

VENDOR

SHIP TO

DIVISION OF NATURAL RESOURCES  
 VARIOUS LOCALES AS INDICATED  
 BY ORDER

DATE PRINTED	TERMS OF SALE	SHIP VIA	F.O.B.	FREIGHT TERMS
04/13/2011				

BID OPENING DATE: **05/24/2011** BID OPENING TIME **01:30PM**

LINE	QUANTITY	UOP	CAT NO	ITEM NUMBER	UNIT PRICE	AMOUNT
<p>BUILDING 15            2019 WASHINGTON STREET, EAST            CHARLESTON, WV 25305-0130</p> <p>THE BID SHOULD CONTAIN THIS INFORMATION ON THE FACE OF            THE ENVELOPE OR THE BID MAY NOT BE CONSIDERED:</p> <p>SEALED BID</p> <p>BUYER: 44</p> <p>RFQ. NO.: DNRB11166</p> <p>BID OPENING DATE: 05/24/2011</p> <p>BID OPENING TIME: 1:30 PM</p> <p>PLEASE PROVIDE A FAX NUMBER IN CASE IT IS NECESSARY            TO CONTACT YOU REGARDING YOUR BID:</p> <p>-----</p> <p>CONTACT PERSON (PLEASE PRINT CLEARLY):</p> <p>-----</p>						

SEE REVERSE SIDE FOR TERMS AND CONDITIONS

SIGNATURE	TELEPHONE	DATE
TITLE	FEIN	ADDRESS CHANGES TO BE NOTED ABOVE

WHEN RESPONDING TO RFQ, INSERT NAME AND ADDRESS IN SPACE ABOVE LABELED 'VENDOR'

WEST VIRGINIA STATE PARKS  
Furniture Purchase, Assembly and Set-Up  
Open End Contract

The West Virginia Division of Natural Resources, hereinafter Division, is requesting Bids for an open ended contract for the purchase of lodge room furniture, lobby furniture, public corridor furniture, outdoor patio and pool furniture and business center furniture to be utilized for upgrades and redecoration of facilities throughout the State. All items are to be F.O.B. Destination. Freight or delivery charges must be included in the price of each individual piece of furniture.

### **General Specifications:**

Furniture must be manufactured for commercial hospitality use. All items must be new. Fabric style and color options must be included with Bid, and fabric choices will be selected with the successful Vendor at the time of Notice to Proceed. These fabric styles and colors will be selected from manufacturer's fabric colors and patterns that meet the minimum specifications found within these Specifications. Scheduling of shipping shall be coordinated between Division and Vendor after the "Notice to Proceed" has been issued by the Division.

### **Information for Bidders:**

Bidders must submit a unit price Bid for each item. Bidders shall have the option to bid on any number of bid packages as listed below:

1. **PACKAGE #1;** Lodge Room Furniture – OPTION #1
2. **PACKAGE #2;** Lodge Room Furniture – OPTION #2
3. **PACKAGE #3;** Lodge Lobby Furniture – OPTION #1
4. **PACKAGE #4;** Lodge Lobby Furniture – OPTION #2
5. **PACKAGE #5;** Bauhaus Interpretive Program Furniture
6. **PACKAGE #6;** Outdoor Patio and Pool Furniture

Bidders who bid on any specific package (1-6) must bid all items in that specific package. Partial or conditional package bids will not be accepted. Quantities listed on the bid forms are for bid evaluation purposes only. Actual quantities ordered may differ.

WEST VIRGINIA STATE PARKS  
Furniture Purchase, Assembly and Set-Up  
Open End Contract

**Basis of Award:**

Each individual package is a stand-alone bid. The Contract will be awarded to the lowest qualified Bidder submitting the lowest Bid per package, for all furniture stipulated on the Bid schedule and in complete accordance with all specifications stipulated herein.

**Coordination:**

Vendor must coordinate shipping and receiving with each individual location.

**Delivery, Storage and Handling:**

The successful Vendor must deliver and handle all items according to Manufacturer's recommendations, including means and methods that will prevent damage, deterioration, and loss. Goods must be delivered in the Manufacturer's original sealed containers complete with labels and instructions for handling, storage, unpacking, protecting, and installing. The Division will supply labor to inspect the goods upon delivery, to ensure compliance with the purchase order, and to ensure all items are undamaged and protected against damage. All items must be delivered according to Manufacturer's recommendations and in an order that will facilitate inspection and measurement of quantity. All items must be delivered using means and methods that will prevent damage, deterioration, theft, or other loss.

**Damaged Items:**

All items will be inspected by the Division subsequent to delivery to ensure that each item is not damaged or defective. Damaged or defective items must be rejected, removed, and replaced at no additional expense to the Division.

**Project Closeout:**

Vendor must provide an inventory list of all items received and accepted. Vendor must provide the manufacturers recommendations for maintenance and cleaning.

WEST VIRGINIA STATE PARKS  
Furniture Purchase, Assembly and Set-Up  
Open End Contract

### Applications for Payment:

Vendor must submit Applications for Payment upon completion of Work for all furniture delivered and accepted and upon completion of project closeout requirements.

### Warranty:

The Vendor must warranty products to be free of defects in materials and Workmanship for a minimum period of one (1) year after date of acceptance or through manufacturer's provided warranty, whichever is greater. Vendor must repair or replace at its discretion, free of charge, any product that proves to be defective during the warranty period.

### Estimated Quantities:

The quantities listed in this bid form are for bid evaluation purposes only – Actual quantities ordered may differ.

### Lodge Information:

Lodge	Total Beds	Kings	Queens	Doubles	Twins	# Rooms
Blackwater	89	9	30	24	26	54
Cacapon	87	0	34	20	33	58
Chief Logan	110	40	70	0	0	75
Hawks Nest	56	1	7	48	0	31
North Bend	56	2	13	41	0	29
Pipestem McKeever	213	12	0	201	0	113
Pipestem Mountain Creek	49	0	0	30	19	30
Twin Falls	64	17	13	34	0	47
Tygart	38	2	36	0	0	20
<b>TOTALS</b>	<b>762</b>	<b>83</b>	<b>203</b>	<b>398</b>	<b>78</b>	<b>457</b>



## **PACKAGE #1 – LODGE ROOM FURNITURE – OPTION #1**

### **Style of Furniture:**

The style of furniture chosen for this package is: TRANSITIONAL STYLE

Transitional style furniture is defined as a combination of both traditional and contemporary. The furniture, finishes, materials and fabrics illustrate a classic, timeless design. Furniture lines are simple yet sophisticated, featuring either straight lines or rounded profiles.

### **Furniture Construction:**

#### **Construction:**

- Joints must be mortised and tenoned, doweled or blocked glued and pinned.
- All corner blocks, braces and screw cleats must be glued and reinforced with staples, nails or screws.
- All corner blocks and braces must be made of solid wood.
- All structural members must be glued and screwed or stapled in place.
- Furniture must be surfaced with matching high-pressure laminate a minimum of .028" thickness that conforms to Federal Specification LP508H.
- Casters and base blocks must be glued and screwed allowing for free movement of the caster.
- All cases over 60" must have a center foot.

#### **Material:**

- Exposed solid parts must be premium grade hardwood
- Unexposed solid parts must be select hardwoods.
- All panels must be cherry veneers
- All veneered panels must be constructed with waterproof glue under controlled pressure.
- Drawer fronts must be hardwood with cherry veneer. Drawer sides and backs must be constructed of Baltic Birch plywood or equal joined front and rear with English style dovetails.
- Drawer guides on Contract design cases must be heavy duty side mounted metal with a minimum 60 lb. load capacity. The guide surfaces must be double dipped epoxy coated to prevent corrosion.
- Particleboard Standards

1. All particle board must meet ANSI A208.1-1993.
  2. Tops with particleboard cores must be lumber banded on a minimum of three sides with edge banding on the back edges if they are not lumber banded.
  3. Cases must have no exposed particleboard.
  4. Particle board used in doors must be banded on all four sides.
- All items must be packed with packaging materials to minimize shipping damage.

**Workmanship:**

- Doors must be properly aligned to insure uniform clearance and operation free of rattle, squeak or rubbing. Catches must be properly aligned and installed with a minimum requirement of two catches on all but small dresser doors.
- Drawers must be custom fitted to insure free running action with no binding, sticking, rattling or squeaking. Drawer guides and runners must be securely fastened and properly positioned to assure correct drawer alignment.
- Cross grain sanding, machine marks, splits, chip outs, veneer checking, or roughness are not permitted on the surface of the finished product.
- Drawer interiors and other interior storage compartments must be sanded smooth and must be free of glue or lacquer runs. Sides, ends and bottoms must be free of splinters, snags, splinters, staples, nails and screws.
- All hardware including hinges, latches, catches and glides must be attached and fitted to operate properly and serve their purpose during transit and use.
- Miter joints must be square, flush, tight and well glued. Exposed case front joints must be tight not exceeding maximum of 1/64".
- Case tops must be attached to the case with screws allowing the top to be pulled down tight against the case.
- Interior screws must be flush or countersunk to the surface of the part where used.
- Assembly and hinge screws must be properly seated and driven flush with the hinge flange.
- All molding and overlays must be nailed from the back of the panel if possible. Face nails or brads are driven flush or set and nail holes filled.

**Appearance and Finish:**

Finishing must meet the following specifications:

- Color of like finishes must be color-fast, uniform, and compatible between pieces manufactured in the plant
- Each finishing material must be formulated and individual batches checked to insure compatibility with the batch and every other material used to produce a color-fast finishing system.
- Interior surfaces of compartments and drawers must be free of dirt, dust, shavings or any foreign matter prior to finishing.
- Finish must be rubbed to required smoothness and sheen and dried to prevent marring or printing on the surface when packed.
- Edges and backs of doors and drawers finished must be compatible with exterior.
- Excess pumice, oil, wax and rubbing compound must be wiped clean after rubbing.

**Performance:**

- Drawers and doors must be fitted and aligned to operate smoothly under various atmospheric conditions.
- All drawers, doors and other operating parts must be properly fitted and aligned to operate smoothly without loose or sloppy action.
- Doors and door hinges must operate smoothly and quietly without binding, rubbing or rattling.
- Hardware, both trim and functional, must be straight and firmly attached.

**Fabric:**

MIDGRADE: All fabric must meet ACT Guidelines specified for hotel / commercial use for abrasion, colorfastness, flammability, physical properties, and dry and wet crocking. Particularly;

- All fabric must meet minimum heavy duty abrasion guideline for hotel use, minimum 30,000 double rubs Wyzenbeek Method
- Minimum Grade 4 Colorfastness
- Minimum California Technical Bulletin #117 Section E – Class 1 (Pass)

- Physical Properties: Class 3 minimum ASTM D3511-01, ASTM D49070-05; 50 lbs minimum in warp and weft, seam slippage 25 lbs minimum in warp and weft
- Grade 4 minimum dry crocking, Grade 3 minimum wet crocking

### **Furniture Specifications:**

Items for this bid must meet these minimum specifications. Fabric, color, hardware and finish selections will be made at the time of award.

MICROFRIDGE CABINET – Thomasville Bridges 2.0 – 355 or equal

- Minimum dimensions must be 58 7/8" W x 23" D x 43 3/4" H
- Must have lumber banded laminate top
- Must have a maximum of three side guided drawers
- Maximum microwave space must be 29 1/2" W x 20 3/8" D x 12" H
- Maximum refrigerator space must be 21" W x 20 3/8" D x 34 1/4" H

3/3 TWIN HEADBOARD – Thomasville Bridges 2.0 – 412 or equal

- Must be wall-hung;
- Minimum dimensions must be 40" W x 22 1/2" H

4/6 FULL PANEL HEADBOARD – Thomasville Bridges 2.0 - 415 or equal

- Must be wall-hung;
- Minimum dimensions must be 53" W x 1 7/8" D x 36" H.

5/0 QUEEN PANEL HEADBOARD – Thomasville Bridges 2.0 - 416 or equal

- Must be wall hung;
- Minimum dimensions must be 60" W x 1 7/8" D x 36" H.

6/6 KING PANEL HEADBOARD – Thomasville Bridges 2.0 – 417 or equal

- Must be wall hung;
- Minimum dimensions must be 78" W X 1 7/8" D X 36" H

NIGHTSTAND #1 – Thomasville Bridges 2.0 - 812 or equal

- Minimum dimensions must be 24 1/8" W x 17 3/4" D x 24" H;
- Must have a minimum of one (1) side guided drawer;
- Must have a minimum of one (1) stationary shelf;
- Must have a lumber banded laminate top; and
- Must have a recessed back.

NIGHTSTAND #2 – Thomasville Bridges 2.0 – 802 or equal

- Minimum dimensions must be 18 W x 17 3/4" D x 24" H;
- Must have a minimum of one (1) side guided drawer;
- Must have a minimum of one (1) stationary shelf;
- Must have a lumber banded laminate top; and

- Must have a recessed back.

DRESSER – Thomasville Bridges 2.0 -126 or equal

- Minimum dimensions must be 67 3/8" W x 21" D x 30" H
- Must have six side-guided drawers
- Must have lumber banded laminate top
- Must have recessed back

MIRROR – Thomasville Bridges 2.0 – 206 or equal

- Minimum dimensions must be 30" W x 1 1/4" D x 46" H;
- Mirror frames must be constructed of solid hard wood; and
- Mirror glass must be a minimum 3/16" plate glass with copper electro-plate backs to protect the silver surface.

TV / VCR CABINET – Thomasville Bridges 2.0 – 351 or equal

- Minimum dimensions must be 36 1/8" H x 21" D x 36 3/4" H
- Minimum VCR space must be 30 1/2" W x 17 3/4" D x 6" H
- Must have three side guided drawers
- Must have one stationary VCR shelf
- Must have lumber banded laminate top
- Must have recessed back

LUGGAGE BENCH – Thomasville Bridges 2.0 - 384 or equal

- Minimum dimensions must be 42" W x 22" D x 18" H
- Must have lumber banded laminate top
- Should have straight legs
- Must have Wall-mount guard included
- Should have ogee edge (front edge only)

DESK– Thomasville Bridges 2.0 – 407 or equal

- Minimum dimensions must be 48" W x 30" D x 30"H;
- Must have a minimum of one (1) side guided drawer;
- Must have lumber banded laminate top;
- Must include a center stationery drawer; and
- Must include an electronic data port unit that attaches to the desk or writing table
- Must have a minimum of 25 1/4" apron to floor

ACTIVITY TABLE – Thomasville Bridges 2.0 - 704 or equal

- Minimum dimensions must be 34" W x 34" D x 30" H;
- Must have an apron to floor minimum dimension of 25 1/4"; and
- Must have lumber banded laminate top.

DESK CHAIR – Thomasville 761 Side Chair or equal

- Minimum dimensions must be 18 ¾" W x 21" D x 35 1/2 " H
- Minimum seat width 18"
- Minimum seat depth 17"
- Minimum seat height 18 ½"
- Minimum fabric yardage: .75 Yards
- Fabric, pattern and color must be coordinated with park and will be selected from manufacturer's fabrics colors and patterns

END TABLE #1 – Thomasville Bridges 2.0 - 4818 or equal

- Minimum dimensions must be 18" Diameter x 24" high
- Must have lumber banded laminate top

END TABLE #2 – Thomasville Bridges 2.0 - 212 or equal

- Minimum dimensions must be 20" W x 24" D x 24" H
- Must have lumber banded laminate top

GUEST LOUNGE CHAIR – Thomasville 412 Lounge chair or equal

- Minimum dimensions must be 31" W x 31" D x 35" H;
- Minimum seat height must be 21";
- Minimum arm height must be 25";
- Fabric, pattern and color must be coordinated with park and will be selected from manufacturer's fabrics colors and patterns

QUEEN SLEEP SOFA – Thomasville 6000-010Q or equal

- Minimum dimensions must be W 67" x D 36" x H 40
- minimum seat height must be 20";
- Minimum arm height must be 30".
- Sleeper must include an upgraded mattress with a minimum 6" thickness;
- Fabric, pattern and color must be coordinated with park and will be selected from manufacturer's fabrics colors and patterns

GUEST ROOM TABLE LAMP – Arkansas Lamps 6031T or equal

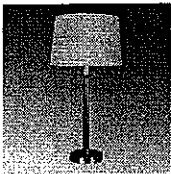

- Minimum height must be 29.25"
- Must have a brushed nickel finish
- Should have a push button switch at base
- Must have a minimum of 8' SPT-2 power supply cord with polarized plug.
- Must include a White Linen Hardback Shade a minimum of 13"x16"x10"

## FLOOR LAMP – Arkansas Lamps 6024F or equal

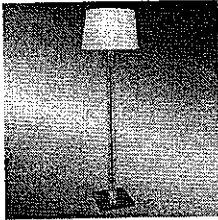

- Must be a minimum of 60" in height;
- Must have a brushed nickel finish;
- Must include a white linen hardback shade a minimum of 14"x17"x11"
- Must have a minimum of a 11' SPT -2 power cord
- Should have a push through on/off socket switch

## BED BASES AND ADA FRAMES

Must be available in:

- Twin 3/3
- Double 4/6
- Queen 5/0
- King 6/6

Standard Pedestal Bed Bases must meet these minimum specifications:

- minimum height must be 7 ½" high
- must have a minimum of three tubular cross supports and inner legs
- must be steel construction
- full, queen and king must have dual center leg supports
- must be constructed of non-combustible materials
- must be available in twin, double, queen and king

ADA Bed Frames must meet these minimum specifications:

- minimum frame must be 1 ½" side angle – 70" length
- must include a minimum 2" head to foot center support
- must include a minimum of six legs with strap braces
- must include a minimum of six adjustable steel glides – min 6" to max 11" in height
- must be available in twin, double, queen and king

## **PACKAGE #2 – LODGE ROOM FURNITURE – OPTION #2**

### **Style of Furniture:**

The style of furniture chosen for this package is: TRANSITIONAL STYLE

Transitional style furniture is defined as a combination of both traditional and contemporary. The furniture, finishes, materials and fabrics illustrate a classic, timeless design. Furniture lines are simple yet sophisticated, featuring either straight lines or rounded profiles.

### **Furniture Construction:**

#### **Construction:**

- Joints must be mortised and tenoned, doweled or blocked glued and pinned.
- All corner blocks, braces and screw cleats must be glued and reinforced with staples, nails or screws.
- All corner blocks and braces must be made of solid wood.
- All structural members must be glued and screwed or stapled in place.
- Furniture must be surfaced with matching high-pressure laminate a minimum of .028" thickness that conforms to Federal Specification LP508H.
- Casters and base blocks must be glued and screwed allowing for free movement of the caster.
- All cases over 60" must have a center foot.

#### **Material:**

- Exposed solid parts must be premium grade hardwood
- Unexposed solid parts must be select hardwoods.
- All panels must be cherry veneers
- All veneered panels must be constructed with waterproof glue under controlled pressure.
- Drawer fronts must be hardwood with cherry veneer. Drawer sides and backs must be constructed of Baltic Birch plywood or equal joined front and rear with English style dovetails.
- Drawer guides on Contract design cases must be heavy duty side mounted metal with a minimum 60 lb. load capacity. The guide surfaces must be double dipped epoxy coated to prevent corrosion.
- Particleboard Standards
  1. All particle board must meet ANSI A208.1-1993.



2. Tops with particleboard cores must be lumber banded on a minimum of three sides with edge banding on the back edges if they are not lumber banded.
  3. Cases must have no exposed particleboard.
  4. Particle board used in doors must be banded on all four sides.
- All items must be packed with packaging materials to minimize shipping damage.

**Workmanship:**

- Doors must be properly aligned to insure uniform clearance and operation free of rattle, squeak or rubbing. Catches must be properly aligned and installed with a minimum requirement of two catches on all but small dresser doors.
- Drawers must be custom fitted to insure free running action with no binding, sticking, rattling or squeaking. Drawer guides and runners must be securely fastened and properly positioned to assure correct drawer alignment.
- Cross grain sanding, machine marks, splits, chip outs, veneer checking, or roughness are not permitted on the surface of the finished product.
- Drawer interiors and other interior storage compartments must be sanded smooth and must be free of glue or lacquer runs. Sides, ends and bottoms must be free of splinters, snags, slivers, staples, nails and screws.
- All hardware including hinges, latches, catches and glides must be attached and fitted to operate properly and serve their purpose during transit and use.
- Miter joints must be square, flush, tight and well glued. Exposed case front joints must be tight not exceeding maximum of 1/64".
- Case tops must be attached to the case with screws allowing the top to be pulled down tight against the case.
- Interior screws must be flush or countersunk to the surface of the part where used.
- Assembly and hinge screws must be properly seated and driven flush with the hinge flange.
- All molding and overlays must be nailed from the back of the panel if possible. Face nails or brads are driven flush or set and nail holes filled.

**Appearance and Finish:**

Finishing must meet the following specifications:

- Color of like finishes must be color-fast, uniform, and compatible between pieces manufactured in the plant
- Each finishing material must be formulated and individual batches checked to insure compatibility with the batch and every other material used to produce a color-fast finishing system.
- Interior surfaces of compartments and drawers must be free of dirt, dust, shavings or any foreign matter prior to finishing.
- Finish must be rubbed to required smoothness and sheen and dried to prevent marring or printing on the surface when packed.
- Edges and backs of doors and drawers finished must be compatible with exterior.
- Excess pumice, oil, wax and rubbing compound must be wiped clean after rubbing.

**Performance:**

- Drawers and doors must be fitted and aligned to operate smoothly under various atmospheric conditions.
- All drawers, doors and other operating parts must be properly fitted and aligned to operate smoothly without loose or sloppy action.
- Doors and door hinges must operate smoothly and quietly without binding, rubbing or rattling.
- Hardware, both trim and functional, must be straight and firmly attached.

**Fabric:**

**MIDGRADE:** All fabric must meet ACT Guidelines specified for hotel / commercial use for abrasion, colorfastness, flammability, physical properties, and dry and wet crocking. Particularly;

- All fabric must meet minimum heavy duty abrasion guideline for hotel use, minimum 30,000 double rubs Wyzenbeek Method
- Minimum Grade 4 Colorfastness
- Minimum California Technical Bulletin #117 Section E – Class 1 (Pass)
- Physical Properties: Class 3 minimum ASTM D3511-01, ASTM D49070-05; 50 lbs minimum in warp and weft, seam slippage 25 lbs minimum in warp and weft
- Grade 4 minimum dry crocking, Grade 3 minimum wet crocking

## **Furniture Specifications:**

Items for this bid must meet these minimum specifications. Fabric, color, hardware and finish selections will be made at the time of award.

- 3/3 TWIN HEADBOARD – Thomasville Changeables 5121 or equal
- Must include heavy duty metal frame with mounting hardware for frame and headboard and carpet wheels
  - Must be made to maximum dimensions of: 39" x 36"
- 4/6 FULL HEADBOARD – Thomasville Changeables 5640 or equal
- Must be wall hung
  - Maximum dimensions must be 54" x 36"
- 5/0 QUEEN HEADBOARD – Thomasville Changeables 5660 or equal
- Must be wall hung
  - Maximum dimensions must be 60" x 36"
- 6/6 KING HEADBOARD – Thomasville Changeables 5680 or equal
- Must be wall hung
  - Maximum dimensions must be 78" x 36"
- DESK – Thomasville Changeables (Student Desk) 7290 or equal
- Maximum dimensions must be 44W" L X 28"D X 30"H
  - Must have maximum of 3 drawers
  - Must have one drop front keyboard drawer
  - Must have laminate top
- DESK CHAIR– Thomasville 4030 Side Chair, or equal
- Maximum dimensions must be 17"W X 21"D X 35.5
  - Maximum seat height must be 18.25'
  - Fabric, pattern and color must be coordinated with park and will be selected from manufacturer's fabrics colors and patterns
- CHEST DRESSER – Thomasville Changeables 3520 or equal
- Maximum dimensions must be 36"W X 22"D X 30"H
  - Must have maximum of 3 side guided drawers
  - Must have lumber banded laminate top
- NIGHTSTAND #1– Thomasville Changeables 8040 or equal
- Maximum dimensions must be 18"W X 16"D X 24"H.
  - Must have one side guide drawer
  - Must have 1 bottom shelf

**NIGHTSTAND #2– Thomasville Changeables 8150 or equal**

- Maximum dimensions must be 30"W X 18"D X 28"H.
- Must have 1 side guide drawer
- Must have 1 bottom shelf

**END TABLE – Thomasville Changeables 2110 or equal**

- Maximum dimensions must be 22"W X 24"D X 25"H.
- Must have lumber banded laminate top

**TV/VCR/REFRIGERATOR CABINET – Thomasville Changeables 3660 or equal**

- Maximum dimensions must be 55"W X 22.5"D X 42 3/8"H
- Must have 3 side guided drawers
- Must have a VCR Shelf
- Must have a refrigerator compartment
- Must have a lumber banded laminate top,
- Must have a recessed back.

**MIRROR – Thomasville Changeables 2400 or equal**

- Maximum dimensions must be 30W" X 46"H
- Mirror frames must be constructed of solid hard wood; and
- Mirror glass must be a minimum 3/16" plate glass with copper electroplate backs to protect the silver surface.

**GUEST ROOM CHAIR - Thomasville Chesapeake 6038 or equal**

- Maximum dimensions must be 39"W X 37"D X 38"H
- Fabric, pattern and color must be coordinated with park and will be selected from manufacturer's fabrics colors and patterns

**BED BASES AND ADA FRAMES**

Must be available in:

- Double 4/6
- Queen 5/0
- King 6/6

Standard Pedestal Bed Bases must meet these maximum specifications:

- minimum height must be 7 1/2" high
- must have a minimum of three tubular cross supports and inner legs
- must be steel construction
- full, queen and king must have dual center leg supports
- must be constructed of non-combustible materials
- must be available in twin, double, queen and king

ADA Bed Frame must meet these maximum specifications:

- must have minimum 1 1/2" side angle – 70" length
- must have minimum 2" head to foot center support

- must have minimum of six legs with strap braces
- must have minimum of six adjustable steel glides – min 6" to max 11" in height
- must be available in double, queen and king

TABLE LAMP – Arkansas Lamp 5665TPL Strasbourg Collection, or equal

- Maximum height must be 29"
- Must have brushed nickel finish
- Should have on/off push button base
- Must have a minimum of 8' cord with polarized plug
- Must have a minimum of 6"x18"x11.5" White Linen Hardback Shade

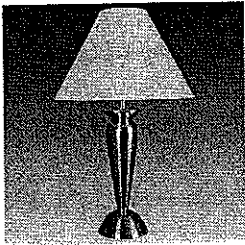

FLOOR LAMP – Arkansas Lamp 5666FPL Strasbourg Collection, or equal

- Maximum height must be 58"
- Must have brushed nickel finish
- Should have on/off push through socket switch
- Must have minimum 11' usable cord with polarized plug
- Must include a minimum of 6"x18"x11.5" White Linen Hardback Shade

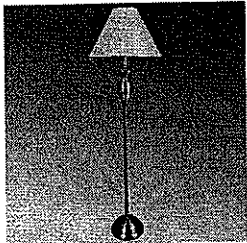

LUGGAGE BENCH – Thomasville Changeables -3870 or equal

- Maximum dimensions must be 42"x22"x18"H
- Must have no drawer, no lift lid
- Must have lumber banded laminate top
- Must have recessed back
- Must include wall mounted guard

ACTIVITY TABLE – Thomasville Changeables – 7030 or equal

- Maximum dimensions must be 34"x34"x30"H

- Must have lumber banded laminate top
- Apron to floor maximum height must be 26 ¼"

SOFA – Thomasville Chesapeake Collection 6338 13 or equal

- Maximum dimensions must be 38" h x 80" w x 37" d
- Should have loose pillow back and seat cushion
- Fabric, pattern and color must be coordinated with park and will be selected from manufacturer's fabrics colors and patterns

## PACKAGE #3 - LODGE LOBBY FURNITURE – OPTION #1

### Style of Furniture:

The style of furniture chosen for this package is: TRANSITIONAL STYLE

Transitional style furniture is defined as a combination of both traditional and contemporary. The furniture, finishes, materials and fabrics illustrate a classic, timeless design. Furniture lines are simple yet sophisticated, featuring either straight lines or rounded profiles.

### Furniture Construction:

#### **Construction:**

- Joints must be mortised and tenoned, doweled or blocked glued and pinned.
- All corner blocks, braces and screw cleats must be glued and reinforced with staples, nails or screws.
- All corner blocks and braces must be made of solid wood.
- All structural members must be glued and screwed or stapled in place.
- Furniture must be surfaced with matching high-pressure laminate a minimum of .028" thickness that conforms to Federal Specification LP508H.
- Casters and base blocks must be glued and screwed allowing for free movement of the caster.
- All cases over 60" must have a center foot.

#### **Material:**

- Exposed solid parts must be premium grade hardwood
- Unexposed solid parts must be select hardwoods.
- All panels must be cherry veneers
- All veneered panels must be constructed with waterproof glue under controlled pressure.
- Drawer fronts must be hardwood with cherry veneer. Drawer sides and backs must be constructed of Baltic Birch plywood or equal joined front and rear with English style dovetails.
- Drawer guides on Contract design cases must be heavy duty side mounted metal with a minimum 60 lb. load capacity. The guide surfaces must be double dipped epoxy coated to prevent corrosion.
- Particleboard Standards

1. All particle board must meet ANSI A208.1-1993.
  2. Tops with particleboard cores must be lumber banded on a minimum of three sides with edge banding on the back edges if they are not lumber banded.
  3. Cases must have no exposed particleboard.
  4. Particle board used in doors must be banded on all four sides.
- All items must be packed with packaging materials to minimize shipping damage.

**Workmanship:**

- Doors must be properly aligned to insure uniform clearance and operation free of rattle, squeak or rubbing. Catches must be properly aligned and installed with a minimum requirement of two catches on all but small dresser doors.
- Drawers must be custom fitted to insure free running action with no binding, sticking, rattling or squeaking. Drawer guides and runners must be securely fastened and properly positioned to assure correct drawer alignment.
- Cross grain sanding, machine marks, splits, chip outs, veneer checking, or roughness are not permitted on the surface of the finished product.
- Drawer interiors and other interior storage compartments must be sanded smooth and must be free of glue or lacquer runs. Sides, ends and bottoms must be free of splinters, snags, slivers, staples, nails and screws.
- All hardware including hinges, latches, catches and glides must be attached and fitted to operate properly and serve their purpose during transit and use.
- Miter joints must be square, flush, tight and well glued. Exposed case front joints must be tight not exceeding maximum of 1/64".
- Case tops must be attached to the case with screws allowing the top to be pulled down tight against the case.
- Interior screws must be flush or countersunk to the surface of the part where used.
- Assembly and hinge screws must be properly seated and driven flush with the hinge flange.
- All molding and overlays must be nailed from the back of the panel if possible. Face nails or brads are driven flush or set and nail holes filled.



**Appearance and Finish:**

Finishing must meet the following specifications:

- Color of like finishes must be color-fast, uniform, and compatible between pieces manufactured in the plant
- Each finishing material must be formulated and individual batches checked to insure compatibility with the batch and every other material used to produce a color-fast finishing system.
- Interior surfaces of compartments and drawers must be free of dirt, dust, shavings or any foreign matter prior to finishing.
- Finish must be rubbed to required smoothness and sheen and dried to prevent marring or printing on the surface when packed.
- Edges and backs of doors and drawers finished must be compatible with exterior.
- Excess pumice, oil, wax and rubbing compound must be wiped clean after rubbing.

**Performance:**

- Drawers and doors must be fitted and aligned to operate smoothly under various atmospheric conditions.
- All drawers, doors and other operating parts must be properly fitted and aligned to operate smoothly without loose or sloppy action.
- Doors and door hinges must operate smoothly and quietly without binding, rubbing or rattling.
- Hardware, both trim and functional, must be straight and firmly attached.

**Fabric:**

MIDGRADE: All fabric must meet ACT Guidelines specified for hotel / commercial use for abrasion, colorfastness, flammability, physical properties, and dry and wet crocking. Particularly;

- All fabric must meet minimum heavy duty abrasion guideline for hotel use, minimum 30,000 double rubs Wyzenbeek Method
- Minimum Grade 4 Colorfastness
- Minimum California Technical Bulletin #117 Section E – Class 1 (Pass)

- Physical Properties: Class 3 minimum ASTM D3511-01, ASTM D49070-05; 50 lbs minimum in warp and weft, seam slippage 25 lbs minimum in warp and weft
- Grade 4 minimum dry crocking, Grade 3 minimum wet crocking

## Furniture Specifications

Items for this bid must meet these minimum specifications. Fabric, color, hardware and finish selections will be made at the time of award.

### LOBBY TABLE LAMP #1 – Arkansas Lamp 5995E or Equal



- Must be a minimum of 27" in height
- Should have rocker switch at base
- Must have dual sockets
- Must have minimum of 10' 3 prong grounded cordset
- Shade minimum dimensions must be least 9x14x10x16x10 white linen hardback shade

### LOBBY TABLE LAMP #2 – Arkansas Lamp 5897TPL or Equal

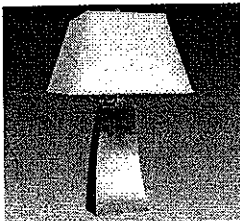

- Must be minimum 26.5" in height
- Must have brushed nickel finish
- Should have on / off push through socket switch
- Must have minimum 8' cord with polarized plug
- Must include a minimum of 9x9x14x14x10 white linen hardback shade

**FLOOR LAMP #1 – Arkansas Lamp 5962F or equal**

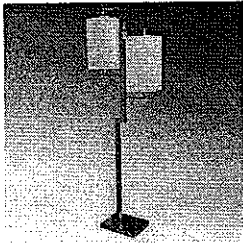

- Minimum height must be 63.5"
- Must have Brushed Nickel finish
- Should have on/off rocker switch,
- Must have a minimum 11' usable cord with polarized plug.
- Must Include two minimum 7"x7"x7"x14" White Linen Hardback Shades.

**FLOOR LAMP #2 – Arkansas Lamp 6052F or equal**

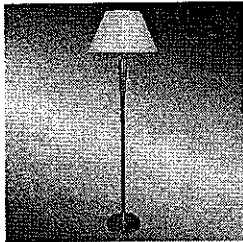

- Minimum height must be 60"
- Must have Brushed Nickel finish
- Should have Espresso accent ring,
- Should have on/off rocker switch at socket,
- Must have a minimum 10" usable SPT-2 power supply cord with polarized plug
- Must have minimum 9x18x10.5 White Linen Hardback Shade

**RECTANGULAR COCKTAIL TABLE – Thomasville Bridges 2.0 40431-110, or equal**

- Minimum dimensions must be 50w x 27d x 19h
- Must have a laminate surface
- Should have minimum of two pull out shelves
- Must have one stationary shelf

**ROUND LAMP TABLE– Thomasville Bridges 2.0 40431-155, or equal**

- Minimum dimensions must be 26" diameter
- Minimum height must be 25"
- Must have a laminate surface

**END TABLE– Thomasville Bridges 2.0 40431-210, or equal**

- Minimum dimensions must be 23w x 27d x 24h
- Must have maximum of one drawer
- Must have maximum of one stationary shelf
- Must have laminate surface

SOFA TABLE-- Thomasville Bridges 2.0 40431-725, or equal

- Minimum dimensions must be 54"W x 18"d x 33"h
- Must have a minimum of two drawers
- Must have minimum of three adjustable shelves
- Must have a laminate surface

SOFA #1 – Thomasville 6300-00R or equal

- Minimum dimensions must be W 70 x D 37 x H 34
- Minimum seat height must be 19 ½"
- Minimum arm height must be 26"
- Must have a maximum of two seat cushions
- Fabric, pattern and color must be coordinated with park and will be selected from manufacturer's fabrics colors and patterns

SOFA #2 – Thomasville 6600-000R or equal

- Minimum dimensions must be W 69 x D 36 x H 36
- Minimum seat height must be 19 ½"
- Minimum arm height must be 27"
- Must have a maximum of two cushions
- Fabric, pattern and color must be coordinated with park and will be selected from manufacturer's fabrics colors and patterns

LOUNGE CHAIR #1 – Thomasville 6600 or equal

- Minimum dimensions must be W 32 X D 32 X H 33
- Minimum seat height must be 19"
- Minimum arm height must be 27"
- Fabric, pattern and color must be coordinated with park and will be selected from manufacturer's fabrics colors and patterns

LOUNGE CHAIR #2 – Thomasville 6300 or equal

- Minimum dimensions must be W 33 x D 34 x H 33
- Minimum seat height must be 19 ½"
- Minimum arm height must be 25"
- Fabric, pattern and color must be coordinated with park and will be selected from manufacturer's fabrics colors and patterns

ENTERTAINMENT CABINET-- Thomasville Bridges 2.0 40441-935, or equal

- Minimum dimensions must be 49 ¼"w x 25 ¾" d x 30 ½" h
- Minimum top size must be 47 ¾ x 25"
- Must have minimum of two doors with minimum one adjustable shelf

- Must have ventilated back panel behind each door

## **PACKAGE #4 – LODGE LOBBY FURNITURE – OPTION #2**

### **Style of Furniture:**

The style of furniture chosen for this package is: TRANSITIONAL STYLE

Transitional style furniture is defined as a combination of both traditional and contemporary. The furniture, finishes, materials and fabrics illustrate a classic, timeless design. Furniture lines are simple yet sophisticated, featuring either straight lines or rounded profiles.

### **Furniture Construction:**

#### **Construction:**

- Joints must be mortised and tenoned, doweled or blocked glued and pinned.
- All corner blocks, braces and screw cleats must be glued and reinforced with staples, nails or screws.
- All corner blocks and braces must be made of solid wood.
- All structural members must be glued and screwed or stapled in place.
- Furniture must be surfaced with matching high-pressure laminate a minimum of .028" thickness that conforms to Federal Specification LP508H.
- Casters and base blocks must be glued and screwed allowing for free movement of the caster.
- All cases over 60" must have a center foot.

#### **Material:**

- Exposed solid parts must be premium grade hardwood
- Unexposed solid parts must be select hardwoods.
- All panels must be cherry veneers
- All veneered panels must be constructed with waterproof glue under controlled pressure.
- Drawer fronts must be hardwood with cherry veneer. Drawer sides and backs must be constructed of Baltic Birch plywood or equal joined front and rear with English style dovetails.
- Drawer guides on Contract design cases must be heavy duty side mounted metal with a minimum 60 lb. load capacity. The guide surfaces must be double dipped epoxy coated to prevent corrosion.
- Particleboard Standards
  1. All particle board must meet ANSI A208.1-1993.
  2. Tops with particleboard cores must be lumber banded on a minimum of three sides with edge banding on the back edges if they are not lumber banded.
  3. Cases must have no exposed particleboard.

4. Particle board used in doors must be banded on all four sides.
- All items must be packed with packaging materials to minimize shipping damage.

**Workmanship:**

- Doors must be properly aligned to insure uniform clearance and operation free of rattle, squeak or rubbing. Catches must be properly aligned and installed with a minimum requirement of two catches on all but small dresser doors.
- Drawers must be custom fitted to insure free running action with no binding, sticking, rattling or squeaking. Drawer guides and runners must be securely fastened and properly positioned to assure correct drawer alignment.
- Cross grain sanding, machine marks, splits, chip outs, veneer checking, or roughness are not permitted on the surface of the finished product.
- Drawer interiors and other interior storage compartments must be sanded smooth and must be free of glue or lacquer runs. Sides, ends and bottoms must be free of splinters, snags, slivers, staples, nails and screws.
- All hardware including hinges, latches, catches and glides must be attached and fitted to operate properly and serve their purpose during transit and use.
- Miter joints must be square, flush, tight and well glued. Exposed case front joints must be tight not exceeding maximum of 1/64".
- Case tops must be attached to the case with screws allowing the top to be pulled down tight against the case.
- Interior screws must be flush or countersunk to the surface of the part where used.
- Assembly and hinge screws must be properly seated and driven flush with the hinge flange.
- All molding and overlays must be nailed from the back of the panel if possible. Face nails or brads are driven flush or set and nail holes filled.

**Appearance and Finish:**

Finishing must meet the following specifications:

- Color of like finishes must be color-fast, uniform, and compatible between pieces manufactured in the plant
- Each finishing material must be formulated and individual batches checked to insure compatibility with the batch and every other material used to produce a color-fast finishing system.
- Interior surfaces of compartments and drawers must be free of dirt, dust, shavings or any foreign matter prior to finishing.

- Finish must be rubbed to required smoothness and sheen and dried to prevent marring or printing on the surface when packed.
- Edges and backs of doors and drawers finished must be compatible with exterior.
- Excess pumice, oil, wax and rubbing compound must be wiped clean after rubbing.

**Performance:**

- Drawers and doors must be fitted and aligned to operate smoothly under various atmospheric conditions.
- All drawers, doors and other operating parts must be properly fitted and aligned to operate smoothly without loose or sloppy action.
- Doors and door hinges must operate smoothly and quietly without binding, rubbing or rattling.
- Hardware, both trim and functional, must be straight and firmly attached.

**Fabric:**

MIDGRADE: All fabric must meet ACT Guidelines specified for hotel / commercial use for abrasion, colorfastness, flammability, physical properties, and dry and wet crocking. Particularly;

- All fabric must meet minimum heavy duty abrasion guideline for hotel use, minimum 30,000 double rubs Wyzenbeek Method
- Minimum Grade 4 Colorfastness
- Minimum California Technical Bulletin #117 Section E – Class 1 (Pass)
- Physical Properties: Class 3 minimum ASTM D3511-01, ASTM D49070-05; 50 lbs minimum in warp and weft, seam slippage 25 lbs minimum in warp and weft
- Grade 4 minimum dry crocking, Grade 3 minimum wet crocking

## Furniture Specifications

Items for this bid must meet these minimum specifications. Fabric, color, hardware and finish selections will be made at the time of award.

DINING ROOM / CONFERENCE ROOM / LOUNGE CHAIR - Thomasville Contract Seating, 761 Side Chair or equal

- Minimum dimensions must be: 18.75"W X 21"D X 35.5"H
- Minimum Seat Height must be 18.5"
- Minimum Seat Depth must be 17.5"
- Must be constructed of Oak-solids hardwood
- Fabric, pattern and color must be coordinated with park and will be selected from manufacturer's fabrics colors and patterns



**LOBBY CHAIR – Thomasville Contract Seating 1122 Wing Chair or equal**

- Minimum dimensions must be 31"W X 32"D X 46"H
- Minimum seat height must be 19" H
- Minimum arm height must be 27" H.
- Fabric, pattern and color must be coordinated with park and will be selected from manufacturer's fabrics colors and patterns

**LOUNGE ROOM SOFA – Thomasville Affinity w/skirt. 8005 12 Sofa or equal**

- Minimum dimensions must be 87" L X 43" D X 39" H
- Must have skirted base
- Should have loose pillow back and loose seat cushion
- Fabric, pattern and color must be coordinated with park and will be selected from manufacturer's fabrics colors and patterns

**LOUNGE ROOM LOVE SEAT – Thomasville Affinity w/skirt 8005 14 Loveseat or equal**

- Minimum dimensions must be 73" L X 43" D X 39" H
- Must have skirted base
- Should have loose pillow back and loose seat cushion
- Fabric, pattern and color must be coordinated with park and will be selected from manufacturer's fabrics colors and patterns

**LOUNGE ROOM CHAIR - Thomasville Affinity w/skirt. 8005 15 Chair or equal**

- Minimum dimensions must be 51" L X 43" D X 39" H
- Must have skirted base
- Should have loose pillow back and loose seat cushion
- Fabric, pattern and color must be coordinated with park and will be selected from manufacturer's fabrics colors and patterns

**LOUNGE COMPUTER DESK – Thomasville Changeables 4090 or equal**

- Minimum dimensions must be 48" W X 30" D X 30" H
- Must have a minimum of one center drawer
- Must have a banded laminate top
- Must have a recessed back

**LOUNGE NIGHT STAND – Thomasville Changeables 8150 or equal**

- Minimum dimensions must be 30"L X 16"D X 24"H
- Must have a minimum of one (1) side glided drawer
- Must have banded laminate top
- Must have a recessed back

**LOUNGE ARMOIRE - Thomasville Changeables 3442 or equal**

- Minimum dimensions must be 36"W X 24"D X 66"H
- Must have a minimum of 2 retractable doors with 1 stationary laminate shelf
- Must have a maximum of 3 pull drawers with side glides
- Must have a banded laminate top
- Must have a recessed back

FLOOR LAMP –Arkansas Lamp, 5494FHD Bridgeport collection, or equal.

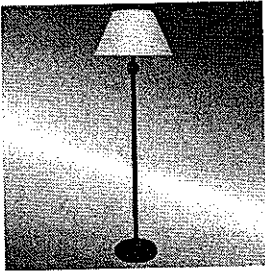

- Minimum dimensions must be 59" in height
- Should have on/off push thru socket switch
- Must have a minimum of 11' usable cord with polarized plug
- Must include a minimum of a 9"x18"x10.5" Natural Linen Hardback Shade

TABLE LAMP- Arkansas table lamp, 5492EHD Bridgeport collection, or equal

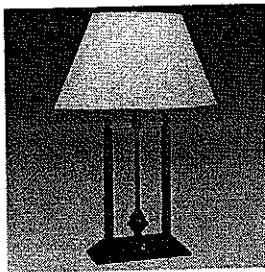

- Minimum dimensions must be 26" in height
- Should have push button base switch
- Must have a minimum of 10' – polarized grounded cordset
- Must include a minimum of a 6"x10"x10"x19"x10" Natural Linen Oval Shade

## PACKAGE #5 – BAUHAUS INTERPRETIVE PROGRAM

### Style of Furniture:

The style of furniture chosen for this package is BAUHAUS MODERN. This style of furniture is to accompany the Bauhaus architecture that is evident in many state park lodges.

### Furniture Specifications

Items for this bid must meet these minimum specifications. Fabric, color, hardware and finish selections will be made at the time of award.

#### ARM CHAIR #1 – Zuo Modern Bounce or equal

- Minimum dimensions must be:

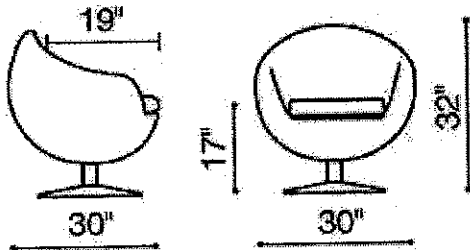

- Must have swivel chrome base
- Must be constructed with tubular frame construction
- Must have similar design to picture above
- Fabric, pattern and color must be coordinated with park and will be selected from manufacturer's fabrics, colors and patterns.

#### ARM CHAIR #2 – Zuo Modern Andromeda or equal

- Minimum dimensions must be:

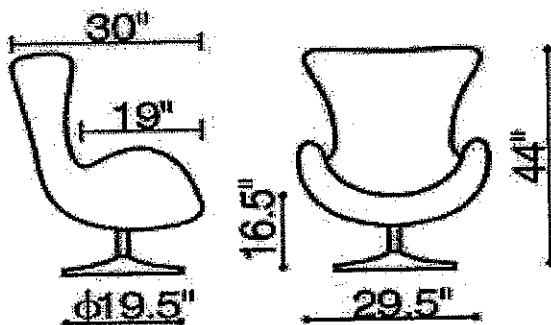

- Must be constructed with tubular frame construction
- Must have swivel chrome base
- Must have similar design to picture above
- Fabric, pattern and color must be coordinated with park and will be selected from manufacturer's fabrics, colors and patterns.

**LOUNGE CHAIR #1 – Zuo Modern Bender Arm Chair or Equal**

- Minimum dimensions must be:

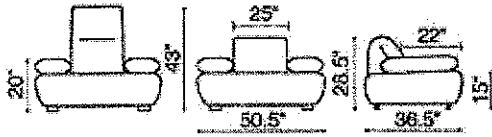

- Must have similar design to picture above
- Fabric, pattern and color must be coordinated with park and will be selected from manufacturer's fabrics, colors and patterns.

**LOUNGE CHAIR #2 – Zuo Modern Event Arm Chair or Equal**

- Minimum dimensions must be:

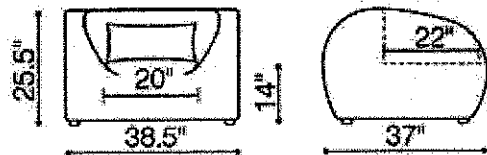

- Fabric should be polyester blend fabric and cushions
- Must have similar design to picture above
- Fabric, pattern and color must be coordinated with park and will be selected from manufacturer's fabrics, colors and patterns.

**SOFA #1 – Zuo Modern – Bender Sofa or Equal**

- Minimum dimensions must be:



- Must have similar design to picture above
- Fabric, pattern and color must be coordinated with park and will be selected from manufacturer's fabrics, colors and patterns.

**SOFA #2 – Zuo Modern – Event Sofa or Equal**

- Minimum dimensions must be:



- Must have similar design to picture above

- Fabric, pattern and color must be coordinated with park and will be selected from manufacturer's fabrics, colors and patterns.

**BISTRO TABLE – Zuo Modern Jupiter Bistro Table or equal**

- Minimum dimensions must be:

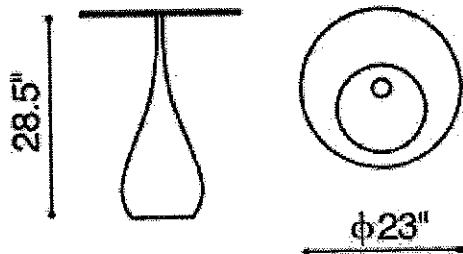

- Must have abs plastic body
- Must have tempered clear glass top
- Must have similar design to picture above
- Color must be coordinated with park and will be selected from manufacturer's colors.

**COFFEE TABLE – Zuo Modern – Rink Coffee Table or Equal**

- Minimum dimensions must be:

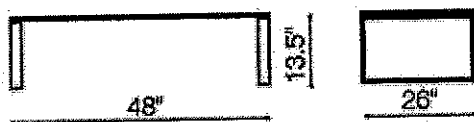

- Must have clear tempered glass top
- Should have silver coated epoxy legs
- Must have similar design to picture above

**SIDE TABLE – Zuo Modern – Jupiter Side Table or Equal**

- Minimum dimensions must be:

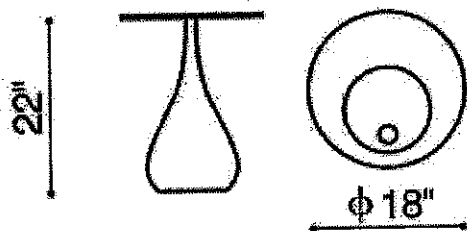

- Must have abs plastic body
- Must have tempered clear glass top
- Must have similar design to picture above
- Color must be coordinated with park and will be selected from manufacturer's colors.

OFFICE CHAIR – Zuo Modern Director Low Back Office Chair or Equal

- Minimum dimensions must be:

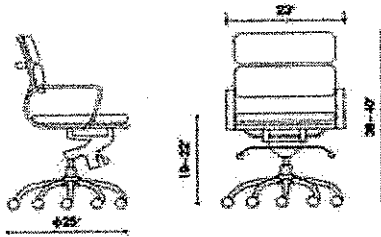

- Must have chrome steel tube frames
- Must have adjustable height locking tilt mechanism
- Must have a cast aluminum base with chrome capped wheels
- Must have similar design to picture above
- Fabric, pattern and color must be coordinated with park and will be selected from manufacturer's fabrics, colors and patterns.

DINING TABLE – Zuo Modern Universe or equal

- Minimum dimensions must be:

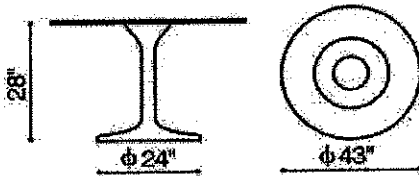

- Must have sculpted fiberglass base
- Must have a tempered glass top
- Must have similar design to picture above

OFFICE DESK – Zuo Modern Thrower Desk or equal

- Minimum dimensions must be



- Must have tempered glass tops

- Must have silver epoxy coated frame
- Must have similar design to picture above

#### DINING CHAIR – Zuo Modern – S Chair or Equal

- Minimum dimensions must be:

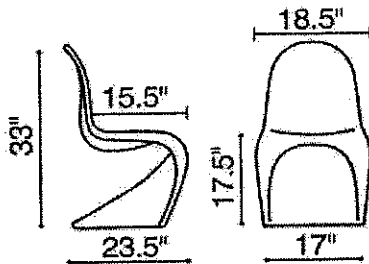

- Must be constructed of shatter resistant ABS plastic
- Must have similar design to picture above
- Color must be coordinated with park and will be selected from manufacturer's colors.

#### TABLE LAMP – Nuevo Living Kairn Table Lamp or Equal

Minimum dimensions must be:

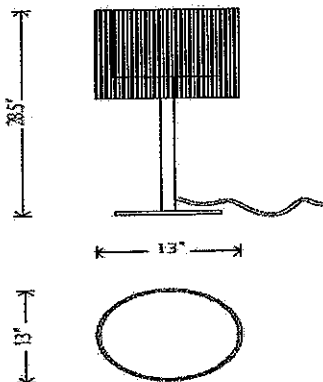

- Must have white mesh fabric outer shade
- Must have white mesh fabric inner shade
- Must have translucent acrylic innermost shade
- Must have brushed aluminum stand and base
- Minimum cord length must be: 77¼"





## PACKAGE #6 - OUTDOOR PATIO AND POOL FURNITURE

### Style of Furniture:

The style of furniture chosen for this package is: PLANTATION TEAK

### Furniture Specifications:

Items for this bid must meet these minimum specifications. Fabric, color, hardware and finish selections will be made at the time of award.

CHAISE – Kara Furniture; Mendocino collection (Ultra Chaise – PC032), or equal

- Minimum dimensions must be 35" W x 81" D x 11" H – Arm Height 24";
- Must be composed of plantation teak;
- Must have stainless steel hardware;
- Must have a multi-position back;
- Must have resin foot pads; and
- Must have mortise and tenon joinery construction.

CHAIR– Kara Furniture; Mendocino collection (Arm Chair – C031-A), or equal

- Minimum dimension must be 23" W x 23" D x 36" H;
- Must have minimum seat height of 17";
- Must have a minimum arm height of 25";
- Must be constructed of plantation teak;
- Must have resin foot pads;
- Must have mortise and tenon joinery construction.

DINING TABLE– Kara Furniture; Mendocino collection (52" Round – TD031-52), or equal

- Minimum dimension must be 52" diameter x 29" H;
- Must be constructed of plantation teak;
- Must have a powder coated aluminum frame;
- Must have a minimum 2" powder coated umbrella hole; and
- Must have a minimum ½" powder coated reducer and cap.

SIDE TABLE – Kara Furniture; Mendocino collection (Ultra End Table – TE032), or equal

- Minimum dimensions must be 22" L x 22" W x 20 H;
- Must be constructed of plantation teak; and
- Must have mortise and tenon joinery construction.

**MANUFACTURER - PACKAGE #1 - LODGE ROOM FURNITURE  
OPTION #1**

Item No.	Description	Manufacturer / Item #
1	MICROFRIDGE CABINET	
2	3/3 TWIN HEADBOARD	
3	4/6 FULL PANEL HEADBOARD	
4	5/0 QUEEN PANEL HEADBOARD	
5	6/6 KING PANEL HEADBOARD	
6	NIGHT STAND #1	
7	NIGHT STAND #2	
8	DRESSER	
9	MIRROR	
10	TV / VCR CABINET	
11	LUGGAGE BENCH	
12	DESK	
13	ACTIVITY TABLE	
14	DESK CHAIR	
15	END TABLE #1	
16	END TABLE #2	

Item No.	Description	Manufacturer / Item #
17	GUEST LOUNGE CHAIR	
18	QUEEN SLEEP SOFA	
19	GUEST ROOM TABLE LAMP	
20	GUEST ROOM FLOOR LAMP	
21	TWIN BED BASE	
22	FULL BED BASE	
23	QUEEN BED BASE	
24	KING BED BASE	
25	ADA TWIN BED BASE	
26	ADA FULL BED BASE	
27	ADA QUEEN BED BASE	
28	ADA KING BED BASE	

**MANUFACTURER - PACKAGE #2 - LODGE ROOM FURNITURE  
OPTION #2**

Item No.	Description	Manufacturer / Item #
1	3/3 TWIN HEADBOARD	
2	4/6 FULL PANEL HEADBOARD	
3	5/0 QUEEN PANEL HEADBOARD	
4	6/6 KING PANEL HEADBOARD	
5	DESK	
6	DESK CHAIR	
7	CHEST DRESSER	
8	NIGHTSTAND #1	
9	NIGHTSTAND #2	
10	END TABLE	
11	TV/VCR/REFRIGERATOR CABINET	
12	MIRROR	
13	GUEST ROOM CHAIR	
14	FULL BED BASE	
15	QUEEN BED BASE	
16	KING BED BASE	
17	ADA FULL BED BASE	

Item No.	Description	Manufacturer / Item #
18	ADA QUEEN BED BASE	
19	ADA KING BED BASE	
20	GUEST ROOM TABLE LAMP	
21	GUEST ROOM FLOOR LAMP	
22	LUGGAGE BENCH	
23	ACTIVITY TABLE	
24	SOFA	

**MANUFACTURER - PACKAGE #3 - LODGE LOBBY FURNITURE****OPTION #1**

Item No.	Description	Manufacturer / Item #
1	LOBBY TABLE LAMP #1	
2	LOBBY TABLE LAMP #2	
3	LOBBY FLOOR LAMP #1	
4	LOBBY FLOOR LAMP #2	
5	RECTANGULAR COCKTAIL TABLE	
6	ROUND LAMP TABLE	
7	END TABLE	
8	SOFA TABLE	
9	SOFA #1	
10	SOFA #2	
11	LOUNGE CHAIR #1	
12	LOUNGE CHAIR #2	
13	ENTERTAINMENT CABINET	

**MANUFACTURER - PACKAGE #4 - LODGE LOBBY FURNITURE  
OPTION #2**

Item No.	Description	Manufacturer / Item #
1	DINING ROOM / CONFERENCE ROOM / LOUNGE CHAIR	
2	LOBBY CHAIR	
3	LOUNGE ROOM SOFA	
4	LOUNGE ROOM LOVE SEAT	
5	LOUNGE ROOM CHAIR	
6	LOUNGE COMPUTER DESK	
7	LOUNGE NIGHT STAND	
8	LOUNGE ARMOIRE	
9	FLOOR LAMP	
10	TABLE LAMP	

**MANUFACTURER - PACKAGE #5 - BAUHAUS INTERPRETIVE PROGRAM**

Item No.	Description	Manufacturer / Item #
1	ARM CHAIR #1	
2	ARM CHAIR #2	
3	LOUNGE CHAIR #1	
4	LOUNGE CHAIR #2	
5	SOFA #1	
6	SOFA #2	
7	BISTRO TABLE	
8	COFFEE TABLE	
9	SIDE TABLE	
10	OFFICE CHAIR	
11	DINING TABLE	
12	OFFICE DESK	
13	DINING CHAIR	
14	TABLE LAMP	



**MANUFACTURER - PACKAGE #6 - OUTDOOR PATIO AND  
POOL FURNITURE**

Item No.	Description	Manufacturer / Item #
1	CHAISE	
2	CHAIR	
3	DINING TABLE	
4	SIDE TABLE	

**BID FORM - PACKAGE #1 - LODGE ROOM FURNITURE - OPTION #1**

NOTE: ALL ITEMS ARE TO BE FOB  
DESTINATION. FREIGHT OR  
DELIVERY CHARGES MUST BE  
INCLUDED IN THE PRICE OF EACH  
LINE ITEM COST. DELIVERY MUST  
BE MADE WITHIN THIRTY DAYS OF  
PURCHASE ORDER AWARD

*THE QUANTITIES LISTED BELOW  
ARE FOR BID EVALUATION  
PURPOSES ONLY. ACTUAL  
QUANTITIES MAY DIFFER*

Item No.	Estimated Quantity	Description	Unit Price	Total Amount
1	120	MICROFRIDGE CABINET		
2	19	3/3 TWIN HEADBOARD		
3	313	4/6 FULL PANEL HEADBOARD		
4	88	5/0 QUEEN PANEL HEADBOARD		
5	32	6/6 KING PANEL HEADBOARD		
6	120	NIGHT STAND #1		
7	120	NIGHT STAND #2		
8	240	DRESSER		
9	240	MIRROR		
10	32	TV / VCR CABINET		
11	180	LUGGAGE BENCH		
12	180	DESK		
13	80	ACTIVITY TABLE		
14	500	DESK CHAIR		

Item No.	Estimated Quantity	Description	Unit Price	Total Amount
15	120	END TABLE #1		
16	120	END TABLE #2		
17	80	GUEST LOUNGE CHAIR		
18	32	QUEEN SLEEP SOFA		
19	500	GUEST ROOM TABLE LAMP		
20	200	GUEST ROOM FLOOR LAMP		
21	13	TWIN BED BASE		
22	307	FULL BED BASE		
23	82	QUEEN BED BASE		
24	26	KING BED BASE		
25	6	ADA TWIN BED BASE		
26	6	ADA FULL BED BASE		
27	6	ADA QUEEN BED BASE		
28	6	ADA KING BED BASE		
<b>TOTAL</b>				\$

NOTE: ALL ITEMS ARE TO BE FOB DESTINATION. FREIGHT OR DELIVERY CHARGES MUST BE INCLUDED IN THE PRICE OF EACH LINE ITEM COST. DELIVERY MUST BE MADE WITHIN THIRTY DAYS OF PURCHASE ORDER AWARD

**THE QUANTITIES LISTED ABOVE ARE FOR BID EVALUATION PURPOSES ONLY. ACTUAL QUANTITIES MAY DIFFER**

## BID FORM - PACKAGE #2 - LODGE ROOM FURNITURE - OPTION #2

NOTE: ALL ITEMS ARE TO BE FOB  
DESTINATION. FREIGHT OR  
DELIVERY CHARGES MUST BE  
INCLUDED IN THE PRICE OF EACH  
LINE ITEM COST. DELIVERY MUST  
BE MADE WITHIN THIRTY DAYS OF  
PURCHASE ORDER AWARD

*THE QUANTITIES LISTED BELOW  
ARE FOR BID EVALUATION  
PURPOSES ONLY. ACTUAL  
QUANTITIES MAY DIFFER*

Item No.	Estimated Quantity	Description	Unit Price	Total Amount
1	59	3/3 TWIN HEADBOARD		
2	44	4/6 FULL PANEL HEADBOARD		
3	64	5/0 QUEEN PANEL HEADBOARD		
4	9	6/6 KING PANEL HEADBOARD		
5	112	DESK		
6	127	DESK CHAIR		
7	112	CHEST DRESSER		
8	4	NIGHTSTAND #1		
9	112	NIGHTSTAND #2		
10	6	END TABLE		
11	10	TV/VCR/REFRIGERATOR CABINET		
12	112	MIRROR		
13	122	GUEST ROOM CHAIR		
14	42	FULL BED BASE		

Item No.	Estimated Quantity	Description	Unit Price	Total Amount
15	62	QUEEN BED BASE		
16	7	KING BED BASE		
17	2	ADA FULL BED BASE		
18	2	ADA QUEEN BED BASE		
19	2	ADA KING BED BASE		
20	224	GUEST ROOM TABLE LAMP		
21	10	GUEST ROOM FLOOR LAMP		
22	102	LUGGAGE BENCH		
23	4	ACTIVITY TABLE		
24	4	SOFA		
<b>TOTAL</b>				\$

NOTE: ALL ITEMS ARE TO BE FOB DESTINATION. FREIGHT OR DELIVERY CHARGES MUST BE INCLUDED IN THE PRICE OF EACH LINE ITEM COST. DELIVERY MUST BE MADE WITHIN THIRTY DAYS OF PURCHASE ORDER AWARD

**THE QUANTITIES LISTED ABOVE  
ARE FOR BID EVALUATION  
PURPOSES ONLY. ACTUAL  
QUANTITIES MAY DIFFER**

## BID FORM - PACKAGE #3 - LODGE LOBBY FURNITURE - OPTION #1

NOTE: ALL ITEMS ARE TO BE FOB  
DESTINATION. FREIGHT OR  
DELIVERY CHARGES MUST BE  
INCLUDED IN THE PRICE OF EACH  
LINE ITEM COST. DELIVERY MUST  
BE MADE WITHIN THIRTY DAYS OF  
PURCHASE ORDER AWARD

**THE QUANTITIES LISTED BELOW  
ARE FOR BID EVALUATION  
PURPOSES ONLY. ACTUAL  
QUANTITIES MAY DIFFER**

Item No.	Estimated Quantity	Description	Unit Price	Total Amount
1	100	LOBBY TABLE LAMP #1		
2	100	LOBBY TABLE LAMP #2		
3	100	LOBBY FLOOR LAMP #1		
4	100	LOBBY FLOOR LAMP #2		
5	25	RECTANGULAR COCKTAIL TABLE		
6	50	ROUND LAMP TABLE		
7	50	END TABLE		
8	20	SOFA TABLE		
9	10	SOFA #1		
10	10	SOFA #2		
11	20	LOUNGE CHAIR #1		
12	20	LOUNGE CHAIR #2		
13	5	ENTERTAINMENT CABINET		
<b>TOTAL</b>				\$

## BID FORM - PACKAGE #4 - LODGE LOBBY FURNITURE - OPTION #2

NOTE: ALL ITEMS ARE TO BE FOB  
DESTINATION. FREIGHT OR  
DELIVERY CHARGES MUST BE  
INCLUDED IN THE PRICE OF EACH  
LINE ITEM COST. DELIVERY MUST  
BE MADE WITHIN THIRTY DAYS OF  
PURCHASE ORDER AWARD

**THE QUANTITIES LISTED BELOW  
ARE FOR BID EVALUATION  
PURPOSES ONLY. ACTUAL  
QUANTITIES MAY DIFFER**

Item No.	Estimated Quantity	Description	Unit Price	Total Amount
1	436	DINING ROOM / CONFERENCE ROOM / LOUNGE CHAIR		
2	12	LOBBY CHAIR		
3	6	LOUNGE ROOM SOFA		
4	8	LOUNGE ROOM LOVE SEAT		
5	12	LOUNGE ROOM CHAIR		
6	2	LOUNGE COMPUTER DESK		
7	24	LOUNGE NIGHT STAND		
8	2	LOUNGE ARMOIRE		
9	6	FLOOR LAMP		
10	24	TABLE LAMP		
<b>TOTAL</b>				\$

## BID FORM - PACKAGE #5 - BAUHAUS INTERPRETIVE PROGRAM

NOTE: ALL ITEMS ARE TO BE FOB  
DESTINATION. FREIGHT OR  
DELIVERY CHARGES MUST BE  
INCLUDED IN THE PRICE OF EACH  
LINE ITEM COST. DELIVERY MUST  
BE MADE WITHIN THIRTY DAYS OF  
PURCHASE ORDER AWARD

*THE QUANTITIES LISTED BELOW  
ARE FOR BID EVALUATION  
PURPOSES ONLY. ACTUAL  
QUANTITIES MAY DIFFER*

Item No.	Estimated Quantity	Description	Unit Price	Total Amount
1	8	ARM CHAIR #1		
2	8	ARM CHAIR #2		
3	6	LOUNGE CHAIR #1		
4	6	LOUNGE CHAIR #2		
5	4	SOFA #1		
6	4	SOFA #2		
7	6	BISTRO TABLE		
8	6	COFFEE TABLE		
9	8	SIDE TABLE		
10	2	OFFICE CHAIR		
11	4	DINING TABLE		
12	2	OFFICE DESK		
13	24	DINING CHAIR		
14	16	TABLE LAMP		
<b>TOTAL</b>				\$



## BID FORM - PACKAGE #6 - OUTDOOR PATIO AND POOL FURNITURE

NOTE: ALL ITEMS ARE TO BE FOB  
DESTINATION. FREIGHT OR  
DELIVERY CHARGES MUST BE  
INCLUDED IN THE PRICE OF EACH  
LINE ITEM COST. DELIVERY MUST  
BE MADE WITHIN THIRTY DAYS OF  
PURCHASE ORDER AWARD

**THE QUANTITIES LISTED BELOW  
ARE FOR BID EVALUATION  
PURPOSES ONLY. ACTUAL  
QUANTITIES MAY DIFFER**

Item No.	Estimated Quantity	Description	Unit Price	Total Amount
1	24	CHAISE		
2	235	CHAIR		
3	12	DINING TABLE		
4	118	SIDE TABLE		
<b>TOTAL</b>				<b>\$</b>

# VENDOR PREFERENCE CERTIFICATE

Certification and application\* is hereby made for Preference in accordance with **West Virginia Code**, §5A-3-37. (Does not apply to construction contracts). **West Virginia Code**, §5A-3-37, provides an opportunity for qualifying vendors to request (at the time of bid) preference for their residency status. Such preference is an evaluation method only and will be applied only to the cost bid in accordance with the **West Virginia Code**. This certificate for application is to be used to request such preference. The Purchasing Division will make the determination of the Resident Vendor Preference, if applicable.

**1. Application is made for 2.5% resident vendor preference for the reason checked:**

- \_\_\_\_\_ Bidder is an individual resident vendor and has resided continuously in West Virginia for four (4) years immediately preceding the date of this certification; **or**,
- \_\_\_\_\_ Bidder is a partnership, association or corporation resident vendor and has maintained its headquarters or principal place of business continuously in West Virginia for four (4) years immediately preceding the date of this certification; or 80% of the ownership interest of Bidder is held by another individual, partnership, association or corporation resident vendor who has maintained its headquarters or principal place of business continuously in West Virginia for four (4) years immediately preceding the date of this certification; **or**,
- \_\_\_\_\_ Bidder is a nonresident vendor which has an affiliate or subsidiary which employs a minimum of one hundred state residents and which has maintained its headquarters or principal place of business within West Virginia continuously for the four (4) years immediately preceding the date of this certification; **or**,

**2. Application is made for 2.5% resident vendor preference for the reason checked:**

- \_\_\_\_\_ Bidder is a resident vendor who certifies that, during the life of the contract, on average at least 75% of the employees working on the project being bid are residents of West Virginia who have resided in the state continuously for the two years immediately preceding submission of this bid; **or**,

**3. Application is made for 2.5% resident vendor preference for the reason checked:**

- \_\_\_\_\_ Bidder is a nonresident vendor employing a minimum of one hundred state residents or is a nonresident vendor with an affiliate or subsidiary which maintains its headquarters or principal place of business within West Virginia employing a minimum of one hundred state residents who certifies that, during the life of the contract, on average at least 75% of the employees or Bidder's affiliate's or subsidiary's employees are residents of West Virginia who have resided in the state continuously for the two years immediately preceding submission of this bid; **or**,

**4. Application is made for 5% resident vendor preference for the reason checked:**

- \_\_\_\_\_ Bidder meets either the requirement of both subdivisions (1) and (2) or subdivision (1) and (3) as stated above; **or**,

**5. Application is made for 3.5% resident vendor preference who is a veteran for the reason checked:**

- \_\_\_\_\_ Bidder is an individual resident vendor who is a veteran of the United States armed forces, the reserves or the National Guard and has resided in West Virginia continuously for the four years immediately preceding the date on which the bid is submitted; **or**,

**6. Application is made for 3.5% resident vendor preference who is a veteran for the reason checked:**

- \_\_\_\_\_ Bidder is a resident vendor who is a veteran of the United States armed forces, the reserves or the National Guard, if, for purposes of producing or distributing the commodities or completing the project which is the subject of the vendor's bid and continuously over the entire term of the project, on average at least seventy-five percent of the vendor's employees are residents of West Virginia who have resided in the state continuously for the two immediately preceding years.

Bidder understands if the Secretary of Revenue determines that a Bidder receiving preference has failed to continue to meet the requirements for such preference, the Secretary may order the Director of Purchasing to: (a) reject the bid; or (b) assess a penalty against such Bidder in an amount not to exceed 5% of the bid amount and that such penalty will be paid to the contracting agency or deducted from any unpaid balance on the contract or purchase order.

By submission of this certificate, Bidder agrees to disclose any reasonably requested information to the Purchasing Division and authorizes the Department of Revenue to disclose to the Director of Purchasing appropriate information verifying that Bidder has paid the required business taxes, provided that such information does not contain the amounts of taxes paid nor any other information deemed by the Tax Commissioner to be confidential.

**Under penalty of law for false swearing (West Virginia Code, §61-5-3), Bidder hereby certifies that this certificate is true and accurate in all respects; and that if a contract is issued to Bidder and if anything contained within this certificate changes during the term of the contract, Bidder will notify the Purchasing Division in writing immediately.**

Bidder: \_\_\_\_\_ Signed: \_\_\_\_\_

Date: \_\_\_\_\_ Title: \_\_\_\_\_

\*Check any combination of preference consideration(s) indicated above, which you are entitled to receive.

RFQ No. \_\_\_\_\_

STATE OF WEST VIRGINIA  
Purchasing Division

**PURCHASING AFFIDAVIT**

**West Virginia Code §5A-3-10a states:** No contract or renewal of any contract may be awarded by the state or any of its political subdivisions to any vendor or prospective vendor when the vendor or prospective vendor or a related party to the vendor or prospective vendor is a debtor and the debt owed is an amount greater than one thousand dollars in the aggregate.

**DEFINITIONS:**

"Debt" means any assessment, premium, penalty, fine, tax or other amount of money owed to the state or any of its political subdivisions because of a judgment, fine, permit violation, license assessment, defaulted workers' compensation premium, penalty or other assessment presently delinquent or due and required to be paid to the state or any of its political subdivisions, including any interest or additional penalties accrued thereon.

"Debtor" means any individual, corporation, partnership, association, limited liability company or any other form or business association owing a debt to the state or any of its political subdivisions. "Political subdivision" means any county commission; municipality, county board of education; any instrumentality established by a county or municipality; any separate corporation or instrumentality established by one or more counties or municipalities, as permitted by law; or any public body charged by law with the performance of a government function or whose jurisdiction is coextensive with one or more counties or municipalities. "Related party" means a party, whether an individual, corporation, partnership, association, limited liability company or any other form or business association or other entity whatsoever, related to any vendor by blood, marriage, ownership or contract through which the party has a relationship of ownership or other interest with the vendor so that the party will actually or by effect receive or control a portion of the benefit, profit or other consideration from performance of a vendor contract with the party receiving an amount that meets or exceed five percent of the total contract amount.

**EXCEPTION:** The prohibition of this section does not apply where a vendor has contested any tax administered pursuant to chapter eleven of this code, workers' compensation premium, permit fee or environmental fee or assessment and the matter has not become final or where the vendor has entered into a payment plan or agreement and the vendor is not in default of any of the provisions of such plan or agreement.

Under penalty of law for false swearing (*West Virginia Code §61-5-3*), it is hereby certified that the vendor affirms and acknowledges the information in this affidavit and is in compliance with the requirements as stated.

**WITNESS THE FOLLOWING SIGNATURE**

Vendor's Name: \_\_\_\_\_

Authorized Signature: \_\_\_\_\_ Date: \_\_\_\_\_

State of \_\_\_\_\_

County of \_\_\_\_\_, to-wit: \_\_\_\_\_

Taken, subscribed, and sworn to before me this \_\_\_\_ day of \_\_\_\_\_, 20\_\_.

My Commission expires \_\_\_\_\_, 20\_\_.

**AFFIX SEAL HERE**

**NOTARY PUBLIC** \_\_\_\_\_