



State of West Virginia  
 Department of Administration  
 Purchasing Division  
 2019 Washington Street East  
 Post Office Box 50130  
 Charleston, WV 25305-0130

# Request for Quotation

RFQ NUMBER  
**DNR210245**

PAGE  
**1**

ADDRESS CORRESPONDENCE TO ATTENTION OF  
**FRANK WHITTAKER**  
**304-558-2316**

VENDOR

RFQ COPY  
 TYPE NAME/ADDRESS HERE

SHIP TO

DIVISION OF NATURAL RESOURCES  
 HAWKS NEST STATE PARK  
 177 WEST MAIN STREET  
 POST OFFICE BOX 857  
 ANSTED, WV  
 25812 304-658-5196

DATE PRINTED	TERMS OF SALE	SHIP VIA	F.O.B.	FREIGHT TERMS
07/19/2010				

BID OPENING DATE: **07/27/2010** BID OPENING TIME **01:30PM**

LINE	QUANTITY	UOP	CAT. NO.	ITEM NUMBER	UNIT PRICE	AMOUNT
***** ADDENDUM NO. 1 *****						
THIS ADDENDUM IS ISSUED TO PROVIDE THE ATTACHED MANDATORY PRE-BID SIGN IN SHEET, BID CLARIFICATION, AND DRAWING.						
BID OPENING DATE AND TIME HAVE NOT CHANGED.						
***** END ADDENDUM NO. 1 *****						
0001	1	LS		968-42		
ROOF REPLACEMENT						
***** THIS IS THE END OF RFQ DNR210245 ***** TOTAL:						

SEE REVERSE SIDE FOR TERMS AND CONDITIONS

SIGNATURE	TELEPHONE	DATE
-----------	-----------	------

TITLE	FEIN	ADDRESS CHANGES TO BE NOTED ABOVE
-------	------	-----------------------------------

WHEN RESPONDING TO RFQ, INSERT NAME AND ADDRESS IN SPACE ABOVE LABELED 'VENDOR'

**GENERAL TERMS & CONDITIONS**  
**REQUEST FOR QUOTATION (RFQ) AND REQUEST FOR PROPOSAL (RFP)**

1. Awards will be made in the best interest of the State of West Virginia.
2. The State may accept or reject in part, or in whole, any bid.
3. Prior to any award, the apparent successful vendor must be properly registered with the Purchasing Division and have paid the required \$125 fee.
4. All services performed or goods delivered under State Purchase Order/Contracts are to be continued for the term of the Purchase Order/Contracts, contingent upon funds being appropriated by the Legislature or otherwise being made available. In the event funds are not appropriated or otherwise available for these services or goods this Purchase Order/Contract becomes void and of no effect after June 30.
5. Payment may only be made after the delivery and acceptance of goods or services.
6. Interest may be paid for late payment in accordance with the *West Virginia Code*.
7. Vendor preference will be granted upon written request in accordance with the *West Virginia Code*.
8. The State of West Virginia is exempt from federal and state taxes and will not pay or reimburse such taxes.
9. The Director of Purchasing may cancel any Purchase Order/Contract upon 30 days written notice to the seller.
10. The laws of the State of West Virginia and the *Legislative Rules* of the Purchasing Division shall govern the purchasing process.
11. Any reference to automatic renewal is hereby deleted. The Contract may be renewed only upon mutual written agreement of the parties.
12. **BANKRUPTCY:** In the event the vendor/contractor files for bankruptcy protection, the State may deem this contract null and void, and terminate such contract without further order.
13. **HIPAA BUSINESS ASSOCIATE ADDENDUM:** The West Virginia State Government HIPAA Business Associate Addendum (BAA), approved by the Attorney General, is available online at [www.state.wv.us/admin/purchase/vrc/hipaa.htm](http://www.state.wv.us/admin/purchase/vrc/hipaa.htm) and is hereby made part of the agreement. Provided that the Agency meets the definition of a Cover Entity (45 CFR §160.103) and will be disclosing Protected Health Information (45 CFR §160.103) to the vendor.
14. **CONFIDENTIALITY:** The vendor agrees that he or she will not disclose to anyone, directly or indirectly, any such personally identifiable information or other confidential information gained from the agency, unless the individual who is the subject of the information consents to the disclosure in writing or the disclosure is made pursuant to the agency's policies, procedures, and rules. Vendor further agrees to comply with the Confidentiality Policies and Information Security Accountability Requirements, set forth in <http://www.state.wv.us/admin/purchase/privacy/noticeConfidentiality.pdf>.
15. **LICENSING:** Vendors must be licensed and in good standing in accordance with any and all state and local laws and requirements by any state or local agency of West Virginia, including, but not limited to, the West Virginia Secretary of State's Office, the West Virginia Tax Department, and the West Virginia Insurance Commission. The vendor must provide all necessary releases to obtain information to enable the director or spending unit to verify that the vendor is licensed and in good standing with the above entities.
16. **ANTITRUST:** In submitting a bid to any agency for the State of West Virginia, the bidder offers and agrees that if the bid is accepted the bidder will convey, sell, assign or transfer to the State of West Virginia all rights, title and interest in and to all causes of action it may now or hereafter acquire under the antitrust laws of the United States and the State of West Virginia for price fixing and/or unreasonable restraints of trade relating to the particular commodities or services purchased or acquired by the State of West Virginia. Such assignment shall be made and become effective at the time the purchasing agency tenders the initial payment to the bidder.

I certify that this bid is made without prior understanding, agreement, or connection with any corporation, firm, limited liability company, partnership, or person or entity submitting a bid for the same material, supplies, equipment or services and is in all respects fair and without collusion or fraud. I further certify that I am authorized to sign the certification on behalf of the bidder or this bid.

**INSTRUCTIONS TO BIDDERS**

1. Use the quotation forms provided by the Purchasing Division. Complete all sections of the quotation form.
2. Items offered must be in compliance with the specifications. Any deviation from the specifications must be clearly indicated by the bidder. Alternates offered by the bidder as **EQUAL** to the specifications must be clearly defined. A bidder offering an alternate should attach complete specifications and literature to the bid. The Purchasing Division may waive minor deviations to specifications.
3. Unit prices shall prevail in case of discrepancy. All quotations are considered F.O.B. destination unless alternate shipping terms are clearly identified in the quotation.
4. All quotations must be delivered by the bidder to the office listed below prior to the date and time of the bid opening. Failure of the bidder to deliver the quotations on time will result in bid disqualifications: Department of Administration, Purchasing Division, 2019 Washington Street East, P.O. Box 50130, Charleston, WV 25305-0130
5. Communication during the solicitation, bid, evaluation or award periods, except through the Purchasing Division, is strictly prohibited (W.Va. C.S.R. §148-1-6.6).

**Hawks Nest State Forest  
Main Lodge, Upper Tram, Lower Tram and Lower Snack Bar  
Buildings Re-Roofing Project  
RFQ DNR210245  
Addendum No. 1**

1. The drain locations have been revised. The revised plan drawing is attached. The contractor shall install new drains in the locations indicated in the drawing. The new drains shall be installed as shown in drawing sheet 7 of 7 and extended a minimum of 12 inches below wood deck or ceiling for others to connect to. Plumbing of the roof drains shall be done by others.
2. The City of Ansted will take the ballast. Contractor is to provide the transport for the ballast.
3. The framing for the old HVAC unit on the main lodge is to be removed.
4. Staging for the main lodge will be possible from either end of the building.
5. The tapered polyisocyanurate insulation shall be 1" minimum thickness with a 1/8:12 slope.

# MANDATORY PRE-BID SIGN-IN ATTENDANCE SHEET

RFQ# : 210245 Bid Date : 4/27/10  
 Project : ROOF REPLACEMENT Pre-Bid Date : 6/30/10

Name : Dale Withrow  
 Company : CHAPMAN TECHNICAL GRP.  
 Address : 200 SIXTH AVE  
ST. ALBANS, WV 25177

Phone # : 304-727-5501  
 Fax # : 304 727-5580  
 Email : dwithrow@chaptech.com

Name : Adam Cowser  
 Company : Kalkreuth Roofing & Siding  
 Address : 411 110th ST.  
Wheeling, WV

Phone # : 304-232-8540  
 Fax # : 304-232-8455  
 Email : acowser@krsn.net

Name : Carol Stevens  
 Company : CAS Structural Engineering  
 Address : PO BOX 469  
Alum Creek, WV 25003

Phone # : 304 756-2564  
 Fax # : 304 756-2565  
 Email : calalane@aol.com

Name : Rachel Merritt  
 Company : Capital Builders  
 Address : 4008 5th St Rd.  
Huntington WV 25701

Phone # : (304) 697-5002  
 Fax # : (304) 697-5004  
 Email : rmerritt.gccapitalbuild@  
Suddenlink.net

Name : BRIAN LINVILLE  
 Company : TRI-STATE ROOFING & Siding  
 Address : PO Box 1231  
CHARLESTON, WV 25324

Phone # : 304-755-8135  
 Fax # : 304-755-5275  
 Email : blinville@tri-statedeservice.com

Name : John Brackley  
 Company : Hawks Nest State Park  
 Address : P.O. Box 857  
ANsted WV 25812

Phone # : 304-658-5196  
 Fax # : 364-658-4549  
 Email : John.brackley@wudnr.gov

Name : Mark J Speirs  
 Company : Mansueti Roofing  
 Address : 116 wood st  
Marbins Ferry, OH  
43935

Phone # : 740-633-7320  
 Fax # : 740-633-7322  
 Email : mark@mansuetiroofing.com

Name : Megan Flinn  
 Company : Hawks Nest State Park  
 Address : PO Box 887  
Amsted, WV 25812

Phone # : 304-658-5196  
 Fax # : 304-658-4549  
 Email : meganflinn@wudnr.gov

ISRAEL LESZIL / Brian Carney

# MANDATORY PRE-BID SIGN-IN ATTENDANCE SHEET

RFQ# : 210245 Bid Date : 7/27/10  
 Project : Roof Replacement Pre-Bid Date : 6/30/10

Name : Andy Wiseman  
 Company : Wiseman Const. Co., Inc  
 Address : 1666 6th Ave., Chas, WV 25302  
awiseman@wisemanconst.com

Name : MICHAEL SIEMNACKO  
 Company : Dan Hill Const  
 Address : PO Box 685  
Gauley Bridge, WV 25098

Phone # : 304 344-1200  
 Fax # : 304 344-1281  
 Email : \_\_\_\_\_

Phone # : 304 632 1600  
 Fax # : 304 632 1501  
 Email : Psirockinwv@hotmail.com

Name : The Garland Co.  
 Company : David Powell  
 Address : 500 Corporate Center Dr.  
5000 River, WV 25760

Name : Craig Brown  
 Company : Pearl Gate Construction  
 Address : 7 Anchors Way  
Winfield, WV 25213

Phone # : 304 77-7777  
 Fax # : \_\_\_\_\_  
 Email : dpowell@garland-co.wv

Phone # : 304-539-8979  
 Fax # : 304-755-4885  
 Email : \_\_\_\_\_

Name : Jo Jones  
 Company : OVAL C/M  
 Address : SUMMER ST.  
CHARLESTON WV 25301

Name : LEONARD FRYE  
~~FRYE ROOFING, INC~~  
 Company : FRYE ROOFING, INC  
 Address : 2000 PRINCETON AVE  
BLUEFIELD, WV 24701

Phone # : (304) 347-8820  
 Fax # : (304) 347-8821  
 Email : \_\_\_\_\_

Phone # : (304) 327-5314  
 Fax # : (304) 325-3700  
 Email : leonard@fryeroofing.com

Name : Dan Hill  
 Company : Danhill Const. Co  
 Address : P.O. Box 685  
Gauley Bridge, WV  
25085

Name : Marcel Albert  
 Company : Frye Roofing  
 Address : 2000 Princeton Ave  
Bluefield, WV

Phone # : 304-632-1600  
 Fax # : 304-632-1501  
 Email : Rdanhill@hotmail.com

Phone # : 304-327-5314  
 Fax # : 304 325 3700  
 Email : Marcel@fryeroofing.com

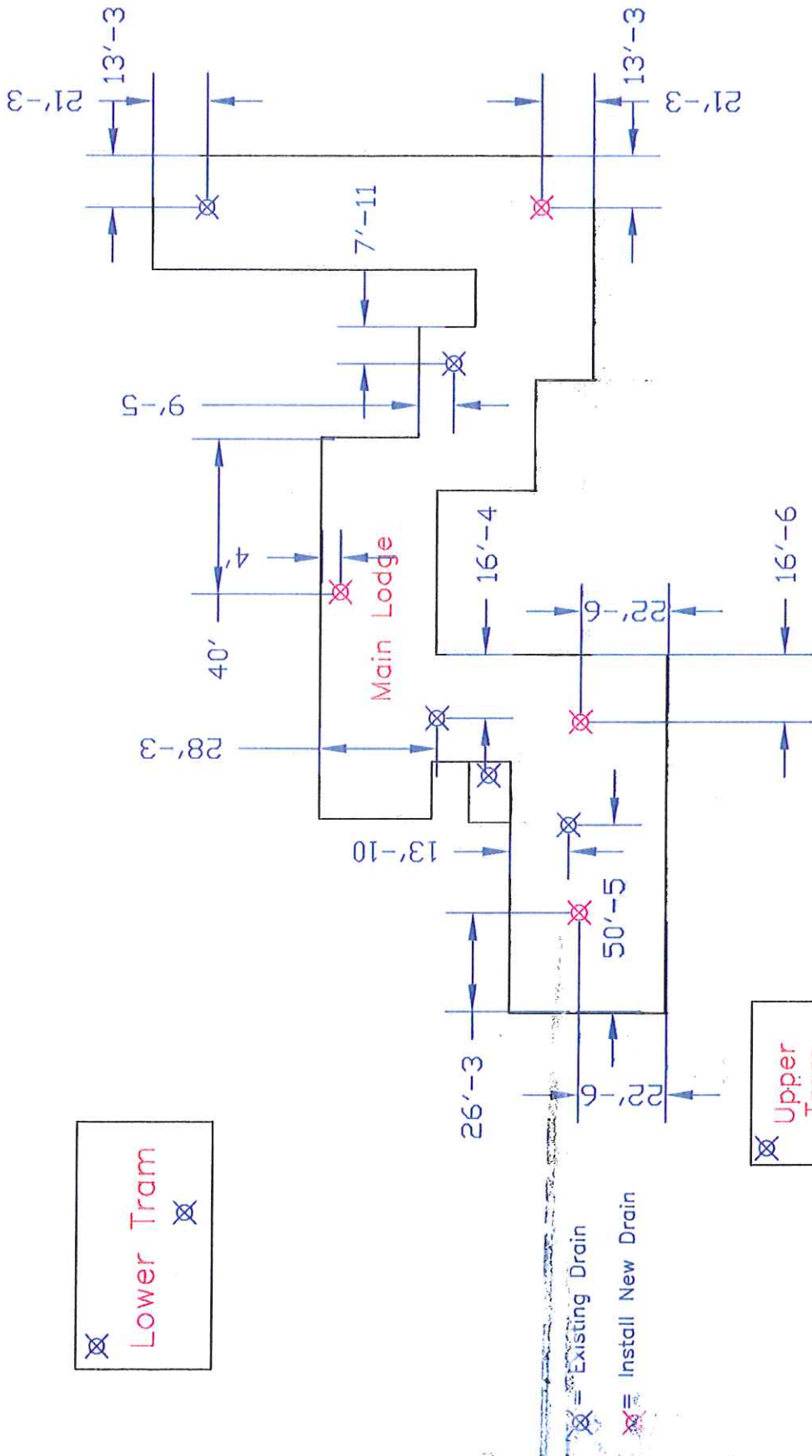

Roof Plan