



State of West Virginia
 Department of Administration
 Purchasing Division
 2019 Washington Street East
 Post Office Box 50130
 Charleston, WV 25305-0130

Request for Quotation

RFQ NUMBER
DNR210240

PAGE
1

ADDRESS CORRESPONDENCE TO ATTENTION OF:
FRANK WHITTAKER 304-558-2316

VENDOR

RFQ COPY
 TYPE NAME/ADDRESS HERE

SHIP TO

DIVISION OF NATURAL RESOURCES
 BLACKWATER FALLS STATE PARK
 ATTN: PARK SUPERINTENDENT
 DRAWER 490
 DAVIS, WV
 26260
 304-259-5216

DATE PRINTED	TERMS OF SALE	SHIP VIA	F.O.B.	FREIGHT TERMS
10/01/2010				

LINE	QUANTITY	UOP	CAT NO.	ITEM NUMBER	BID OPENING TIME	UNIT PRICE	AMOUNT
		11/04/2010			01:30PM		

0001	1	LS		420-40			
<p>FURNITURE</p> <p>THE WEST VIRGINIA PURCHASING DIVISION, FOR THE AGENCY, THE WEST VIRGINIA DIVISION OF NATURAL RESOURCES IS SOLICITING BIDS FROM RESPONSIBLE VENDORS TO PROVIDE FURNISHINGS, DELIVERY AND INSTALLATION FOR THIRTEEN (13) CABINS AT BLACKWATER FALLS STATE PARK PER THE ATTACHED SPECIFICATIONS.</p> <p>ALL TECHNICAL QUESTIONS MUST BE SUBMITTED IN WRITING TO FRANK WHITTAKER IN THE WV PURCHASING DIVISION VIA EMAIL AT FRANK.M.WHITTAKER@WV.GOV OR VIA FAX AT 304-558-4115. DEADLINE FOR TECHNICAL QUESTIONS IS 10/13/10 AT 4:00 PM. ALL TECHNICAL QUESTIONS WILL BE ADDRESSED BY ADDENDUM AFTER THE DEADLINE.</p> <p>BANKRUPTCY: IN THE EVENT THE VENDOR/CONTRACTOR FILES FOR BANKRUPTCY PROTECTION, THE STATE MAY DEEM THE CONTRACT NULL AND VOID, AND TERMINATE SUCH CONTRACT WITHOUT FURTHER ORDER.</p> <p>THE MODEL/BRAND/SPECIFICATIONS NAMED HEREIN ESTABLISH THE ACCEPTABLE LEVEL OF QUALITY ONLY AND ARE NOT INTENDED TO REFLECT A PREFERENCE OR FAVOR ANY PARTICULAR BRAND OR VENDOR. VENDORS WHO ARE BIDDING ALTERNATES SHOULD SO STATE AND INCLUDE PERTINENT LITERATURE AND SPECIFICATIONS. FAILURE TO PROVIDE INFORMATION FOR ANY ALTERNATES MAY BE GROUNDS FOR REJECTION OF THE BID. THE STATE RESERVES THE RIGHT TO WAIVE MINOR IRREGULARITIES IN BIDS OR SPECIFICATIONS IN ACCORDANCE WITH SECTION 148-1-4 (F) OF THE WEST</p>							

SEE REVERSE SIDE FOR TERMS AND CONDITIONS			
SIGNATURE	TELEPHONE	DATE	
TITLE	FEIN	ADDRESS CHANGES TO BE NOTED ABOVE	

WHEN RESPONDING TO RFQ, INSERT NAME AND ADDRESS IN SPACE ABOVE LABELED 'VENDOR'

GENERAL TERMS & CONDITIONS REQUEST FOR QUOTATION (RFQ) AND REQUEST FOR PROPOSAL (RFP)

1. Awards will be made in the best interest of the State of West Virginia.
2. The State may accept or reject in part, or in whole, any bid.
3. Prior to any award, the apparent successful vendor must be properly registered with the Purchasing Division and have paid the required \$125 fee.
4. All services performed or goods delivered under State Purchase Order/Contracts are to be continued for the term of the Purchase Order/Contracts, contingent upon funds being appropriated by the Legislature or otherwise being made available. In the event funds are not appropriated or otherwise available for these services or goods this Purchase Order/Contract becomes void and of no effect after June 30.
5. Payment may only be made after the delivery and acceptance of goods or services.
6. Interest may be paid for late payment in accordance with the *West Virginia Code*.
7. Vendor preference will be granted upon written request in accordance with the *West Virginia Code*.
8. The State of West Virginia is exempt from federal and state taxes and will not pay or reimburse such taxes.
9. The Director of Purchasing may cancel any Purchase Order/Contract upon 30 days written notice to the seller.
10. The laws of the State of West Virginia and the *Legislative Rules* of the Purchasing Division shall govern the purchasing process.
11. Any reference to automatic renewal is hereby deleted. The Contract may be renewed only upon mutual written agreement of the parties.
12. **BANKRUPTCY:** In the event the vendor/contractor files for bankruptcy protection, the State may deem this contract null and void, and terminate such contract without further order.
13. **HIPAA BUSINESS ASSOCIATE ADDENDUM:** The West Virginia State Government HIPAA Business Associate Addendum (BAA), approved by the Attorney General, is available online at www.state.wv.us/admin/purchase/vrc/hipaa.htm and is hereby made part of the agreement. Provided that the Agency meets the definition of a Cover Entity (45 CFR §160.103) and will be disclosing Protected Health Information (45 CFR §160.103) to the vendor.
14. **CONFIDENTIALITY:** The vendor agrees that he or she will not disclose to anyone, directly or indirectly, any such personally identifiable information or other confidential information gained from the agency, unless the individual who is the subject of the information consents to the disclosure in writing or the disclosure is made pursuant to the agency's policies, procedures, and rules. Vendor further agrees to comply with the Confidentiality Policies and Information Security Accountability Requirements, set forth in <http://www.state.wv.us/admin/purchase/privacy/noticeConfidentiality.pdf>.
15. **LICENSING:** Vendors must be licensed and in good standing in accordance with any and all state and local laws and requirements by any state or local agency of West Virginia, including, but not limited to, the West Virginia Secretary of State's Office, the West Virginia Tax Department, and the West Virginia Insurance Commission. The vendor must provide all necessary releases to obtain information to enable the director or spending unit to verify that the vendor is licensed and in good standing with the above entities.
16. **ANTITRUST:** In submitting a bid to any agency for the State of West Virginia, the bidder offers and agrees that if the bid is accepted the bidder will convey, sell, assign or transfer to the State of West Virginia all rights, title and interest in and to all causes of action it may now or hereafter acquire under the antitrust laws of the United States and the State of West Virginia for price fixing and/or unreasonable restraints of trade relating to the particular commodities or services purchased or acquired by the State of West Virginia. Such assignment shall be made and become effective at the time the purchasing agency tenders the initial payment to the bidder.

I certify that this bid is made without prior understanding, agreement, or connection with any corporation, firm, limited liability company, partnership, or person or entity submitting a bid for the same material, supplies, equipment or services and is in all respects fair and without collusion or fraud. I further certify that I am authorized to sign the certification on behalf of the bidder or this bid.

INSTRUCTIONS TO BIDDERS

1. Use the quotation forms provided by the Purchasing Division. Complete all sections of the quotation form.
2. Items offered must be in compliance with the specifications. Any deviation from the specifications must be clearly indicated by the bidder. Alternates offered by the bidder as **EQUAL** to the specifications must be clearly defined. A bidder offering an alternate should attach complete specifications and literature to the bid. The Purchasing Division may waive minor deviations to specifications.
3. Unit prices shall prevail in case of discrepancy. All quotations are considered F.O.B. destination unless alternate shipping terms are clearly identified in the quotation.
4. All quotations must be delivered by the bidder to the office listed below prior to the date and time of the bid opening. Failure of the bidder to deliver the quotations on time will result in bid disqualifications: Department of Administration, Purchasing Division, 2019 Washington Street East, P.O. Box 50130, Charleston, WV 25305-0130
5. Communication during the solicitation, bid, evaluation or award periods, except through the Purchasing Division, is strictly prohibited (W.Va. C.S.R. §148-1-6.6).



State of West Virginia
 Department of Administration
 Purchasing Division
 2019 Washington Street East
 Post Office Box 50130
 Charleston, WV 25305-0130

Request for Quotation

RFQ NUMBER
DNR210240

PAGE
2

ADDRESS CORRESPONDENCE TO ATTENTION OF:
FRANK WHITTAKER 304 558 2316

VENDOR

RFQ COPY
 TYPE NAME/ADDRESS HERE

SHIP TO

DIVISION OF NATURAL RESOURCES
 BLACKWATER FALLS STATE PARK
 ATTN: PARK SUPERINTENDENT
 DRAWER 490
 DAVIS, WV
 26260 304-259-5216

DATE PRINTED	TERMS OF SALE	SHIP VIA	F.O.B.	FREIGHT TERMS
10/01/2010				

BID OPENING DATE: 11/04/2010 BID OPENING TIME 01:30PM

LINE	QUANTITY	UOP	CAT NO	ITEM NUMBER	UNIT PRICE	AMOUNT
VIRGINIA LEGISLATIVE RULES AND REGULATIONS. NOTICE A SIGNED BID MUST BE SUBMITTED TO: DEPARTMENT OF ADMINISTRATION PURCHASING DIVISION BUILDING 15 2019 WASHINGTON STREET, EAST CHARLESTON, WV 25305-0130 THE BID SHOULD CONTAIN THIS INFORMATION ON THE FACE OF THE ENVELOPE OR THE BID MAY NOT BE CONSIDERED: SEALED BID BUYER: 44 RFQ. NO.: DNR210240 BID OPENING DATE: 11/04/2010 BID OPENING TIME: 1:30 PM PLEASE PROVIDE A FAX NUMBER IN CASE IT IS NECESSARY TO CONTACT YOU REGARDING YOUR BID: -----						

SEE REVERSE SIDE FOR TERMS AND CONDITIONS

SIGNATURE	TELEPHONE	DATE
-----------	-----------	------

TITLE	FEIN	ADDRESS CHANGES TO BE NOTED ABOVE
-------	------	-----------------------------------

WHEN RESPONDING TO RFQ, INSERT NAME AND ADDRESS IN SPACE ABOVE LABELED 'VENDOR'



State of West Virginia
 Department of Administration
 Purchasing Division
 2019 Washington Street East
 Post Office Box 50130
 Charleston, WV 25305-0130

Request for Quotation

RFQ NUMBER
 DNR210240

PAGE
 3

ADDRESS CORRESPONDENCE TO ATTENTION OF
 FRANK WHITTAKER
 304-558-2316

VENDOR

RFQ COPY
 TYPE NAME/ADDRESS HERE

SHIP TO

DIVISION OF NATURAL RESOURCES
 BLACKWATER FALLS STATE PARK
 ATTN: PARK SUPERINTENDENT
 DRAWER 490
 DAVIS, WV
 26260
 304-259-5216

DATE PRINTED	TERMS OF SALE	SHIP VIA	F.O.B.	FREIGHT TERMS
10/01/2010				

BID OPENING DATE: 11/04/2010 BID OPENING TIME 01:30PM

LINE	QUANTITY	UOP	CAT. NO.	ITEM NUMBER	UNIT PRICE	AMOUNT
CONTACT PERSON (PLEASE PRINT CLEARLY):						

***** THIS IS THE END OF RFQ DNR210240 ***** TOTAL: _____						

SEE REVERSE SIDE FOR TERMS AND CONDITIONS

SIGNATURE	TELEPHONE	DATE
TITLE	FEIN	ADDRESS CHANGES TO BE NOTED ABOVE

WHEN RESPONDING TO RFQ, INSERT NAME AND ADDRESS IN SPACE ABOVE LABELED 'VENDOR'

DNR210240
Blackwater Falls State Park
Furnishings Purchase, Assembly and Installation

The West Virginia Division of Natural Resources, hereinafter Division, is requesting Bids for the purchase and installation of furniture, bedspreads, curtains, hardware, mirrors, artwork, lamps and closet organizers and assembly thereof for its new thirteen (13) cabins at Blackwater Falls State Park. All items are to be F.O.B. Destination. Freight or delivery charges must be included in the unit cost of each item. Delivery must be coordinated with Blackwater Falls State Park to meet the time frame of the scheduled opening of the new cabins.

Substitutions:

All furnishings must be manufactured for commercial hospitality use. If bidding "or equal brands" attach manufacturer's literature documenting that it meets the mandatory requirements stated in the specifications. Vendors should note the areas of the provided manufacturer's literature that adheres to the mandatory requirements outlined in the Request for Quotation. Fabric choices will be selected from manufacturer's fabric colors and patterns that meet the minimum specifications found within these Specifications. Pattern and color of fabrics must be coordinated with the Division and will be selected from manufacturer's fabric colors and patterns.

Information for Bidders:

It is the preference of the West Virginia Division of Natural Resources that a purchase order be awarded to a single vendor; however, the award may be split if it is in the best interest of the Division.

Basis of Award:

The Contract will be awarded to the lowest qualified Bidder submitting the lowest Bid for the furnishings stipulated on the Bid schedule and in complete accordance with all specifications stipulated herein.

Coordination:

Vendor must coordinate shipping and receiving with the West Virginia Division of Natural Resources, Blackwater Falls State Park.

Delivery, Storage and Handling:

The successful Vendor must deliver and handle all items according to Manufacturer's recommendations, including means and methods that will prevent damage, deterioration, and loss. Goods must be delivered in the Manufacturer's original sealed containers complete with

DNR210240
Blackwater Falls State Park
Furnishings Purchase, Assembly and Installation

labels and instructions for handling, storage, unpacking, and protecting. The successful vendor must inspect the goods upon delivery, to ensure compliance with the purchase order, and to ensure all items are undamaged and protected against damage. All items must be delivered according to Manufacturer's recommendations and in an order that will facilitate inspection and measurement of quantity. All items must be delivered using means and methods that will prevent damage, deterioration, theft, or other loss.

Furniture Assembly and Installation:

Vendor must coordinate complete furnishings assembly and installation with the Division. The successful Vendor must assemble all furniture and install draperies, hardware and additional items purchased under this Purchase Order pursuant to their bid according to manufacturer's guidelines. Vendor must assemble all furniture in appropriate locations as directed by the Division. Vendor must clean up work area and dispose of boxes, packaging material and installation debris. The Division will conduct a pre-assembly and set-up details walkthrough prior to the actual assembly and setup. The Vendor must coordinate this meeting with the Division.

Damaged Items:

All items must be packed with packaging materials to minimize shipping damage. Damaged or defective items must be rejected, removed, and replaced at no additional expense to the Division. The Vendor will be responsible for damages that occur during assembly and set-up.

Project Closeout:

Vendor must provide an inventory list of all items received and accepted. Vendor must provide the manufacturers recommendations for maintenance and cleaning.

Applications for Payment:

Vendor may submit Applications for Payment at the end of each month for any work completed the proceeding month and upon the completion of the work and project closeout requirements. 5% retainage will be deducted from the total amount due, until completion of the entire contract in an acceptable manner.

DNR210240
Blackwater Falls State Park
Furnishings Purchase, Assembly and Installation

Warranty:

The Vendor must warranty products to be free of defects in materials and Workmanship for a period of one (1) year after date of acceptance or through manufacturer's provided warranty, whichever is greater. Vendor must repair or replace at its' discretion, free of charge, any product that proves to be defective during the warranty period.

SPECIFICATIONS:

Room Furnishings

All furniture pieces must have nylon floor protection devices installed.

Sofa must meet the following specifications:

- AC Furniture Item # 78003 Fabric: Village Seaside Finish: 1778 oak Wilson Art Beigewood or equal;
- Dimensions must be between 69-72" L x 36-39" D x 33-36" H;
- Must have oak stained finish;
- Fabric must be Grade 3;
- Must have tapered wood feet;
- Exposed wood frames must be made from premium grade kiln-dried hardwood;
- Upholstery fabrics must meet specifications Cal 117 Section E, BIFMA Class 1, UFAC Class 1 and NFPA 260 for flammability;
- Foam must be polyurethane of a minimum density of 1.8 lbs., meeting California Bulletin 117 specifications;
- Springs must be sinuous wire 11 gage minimum in backs and 9 gage minimum in seat installed with insulated clips and cross wire clip to each spring; and
- All stress points must be glued, double doweled and/or screwed to achieve maximum strength.

Loveseat must meet the following specification:

- AC Furniture Item # 78002 Fabric: Village Seaside Finish: 1778 oak Wilson Art Beigewood or equal;
- Dimensions must be between 57-60" L x 36-39" D x 33-36" H;
- Must have oak stained finish;
- Fabric must be Grade 3;
- Must have tapered wood feet;
- Exposed wood frames must be made from premium grade kiln-dried hardwood;

DNR210240
Blackwater Falls State Park
Furnishings Purchase, Assembly and Installation

- Upholstery fabrics must meet specifications Cal 117 Section E, BIFMA Class 1, UFAC Class 1 and NFPA 260 for flammability;
- Foam must be polyurethane of a minimum density of 1.8 lbs., meeting California Bulletin 117 specifications;
- Springs must be sinuous wire 11 gage minimum in backs and 9 gage minimum in seat installed with insulated clips and cross wire clip to each spring; and
- All stress points must be glued, double doweled and/or screwed to achieve maximum strength.

Guest table in living room must meet the following specifications:

- AC Furniture Item # 130 Finish: 1778 oak Wilson Art Beigewood or equal;
- Dimensions must be between 29-31" W x 29-31" D x 29-31" H;
- Must have shaped top;
- Must have square wood leg;
- Must have oak stained finish;
- Must have laminated top with matching high-pressure laminate that conforms to NEMA LD3; and
- All stress points must be glued, double doweled and/or screwed to achieve maximum strength.

End table in living room must meet the following specifications:

- AC Furniture Item # 4219 Finish: 1778 oak Wilson Art Beigewood or equal;
- Dimensions must be between 19-22" W x 23-26" D x 21-24" H;
- Must have shaped top with round turned leg;
- Must have oak stained finish;
- Must have laminated top with matching high-pressure laminate that conforms to NEMA LD3; and
- All stress points must be glued, double doweled and/or screwed to achieve maximum strength.

Dining Room Trestle table must meet the following specifications:

- AC Furniture Item # 1778 Finish: 1778 oak Wilson Art Beigewood or equal;
- Dimensions must be between 30-36" W x 76-80" D x 29-32" H;
- Must be solid wood table;
- Must have oak stained finish; and
- Must be trestle table support design.

Dining room side chair must meet the following specifications:

DNR210240
Blackwater Falls State Park
Furnishings Purchase, Assembly and Installation

- AC Furniture Item # 715 Fabric: AM71117 Finish: 1778 oak Wilson Art Beigewood or equal;
- Dimensions must be between 20-22" W x 22-25" D x 36-39" H;
- Must have upholstered back and seat;
- Must be Grade 2 fabric;
- Fabric must exceed 30,000 double rubs;
- Must include stain resistant treatment on fabric equal to Teflon treatment;
- Must have oak stained finish;
- Must have H-stretcher support;
- Upholstery fabrics must meet specifications Cal 117 Section E, BIFMA Class 1, UFAC Class 1 and NFPA 260 for flammability; and
- All stress points must be glued, double doweled and/or screwed to achieve maximum strength.

Bar stool side chair must meet the following specifications:

- AC Furniture Item # 693 with custom chair leg length to fit counter height, Fabric: AM71117 Finish: 1778 oak Wilson Art Beigewood or equal;
- Dimensions must be between 17-20" W x 19-22" D x 38-41" H;
- Seat height must be 26" to accommodate counter height;
- Must have upholstered back and seat board;
- Must be Grade 2 fabric;
- Fabric must exceed 30,000 double rubs;
- Must include stain resistant treatment on fabric equal to Teflon treatment;
- Must have oak stained finish;
- Must have brass trim foot rest;
- Upholstery fabrics must meet specifications Cal 117 Section E, BIFMA Class 1, UFAC Class 1 and NFPA 260 for flammability; and
- All stress points must be glued, double doweled and/or screwed to achieve maximum strength.

Sofa table in dining room must meet the following specifications:

- AC Furniture Item #4240 Finish: 1778 oak Wilson Art Beigewood or equal;
- Dimensions must be between 41-43" W x 15-17" D x 29-31" H;
- Must have shaped top with round turned leg;
- Must have oak stained finish;
- Must have laminated top with matching high-pressure laminate that conforms to NEMA LD3; and
- All stress points must be glued, double doweled and/or screwed to achieve maximum strength.

DNR210240
Blackwater Falls State Park
Furnishings Purchase, Assembly and Installation

Sofa table in bedrooms #1 & #2 must meet the following specifications:

- AC Furniture Item #1440 Finish: white washed or equal;
- Dimensions must be between 41-43" W x 15-17" D x 29-31" H;
- Must have shaped top with grooved leg;
- Must have white washed finish;
- Must have laminated top with matching high-pressure laminate that conforms to NEMA LD3; and
- All stress points must be glued, double doweled and/or screwed to achieve maximum strength.

Sofa table in bedrooms #3 & #4 must meet the following specifications:

- AC Furniture Item #1140 Finish: Figured Mahogany or equal;
- Dimensions must be between 41-43" W x 15-17" D x 29-31" H;
- Must have shaped top with square tapered leg;
- Must have mahogany stained finish;
- Must have laminated top with matching high-pressure laminate that conforms to NEMA LD3;
- All stress points must be glued, double doweled and/or screwed to achieve maximum strength; and
- No H-stretcher allowed. Must allow desk chair to fit underneath.

Lounge chair in Queen bedrooms #1 and #2 must meet the following specifications:

- AC Furniture Item # 9400 Fabric: Highlands Topaz or equal;
- Dimensions must be between 29-32" W x 27-30" D x 31-34" H;
- Fabric must be Grade 3;
- Must be open in the front under the seat to accept matching ottoman;
- Must have fully upholstered back and web seat;
- Upholstery fabrics must meet specifications Cal 117 Section E, BIFMA Class 1, UFAC Class 1 and NFPA 260 for flammability; and
- All stress points must be glued, double doweled and/or screwed to achieve maximum strength.

Lounge chair ottoman in Queen bedrooms #1 and #2 must meet the following specifications:

- AC Furniture Item # 941 Fabric: Highlands Topaz or equal;
- Dimensions must fit opening under bedrooms #1 & #2 lounge chair seat;
- Must be fully upholstered;
- Fabric must be Grade 3;

DNR210240
Blackwater Falls State Park
Furnishings Purchase, Assembly and Installation

- Must have wheel casters;
- Upholstery fabrics must meet specifications Cal 117 Section E, BIFMA Class 1, UFAC Class 1 and NFPA 260 for flammability; and
- All stress points must be glued, double doweled and/or screwed to achieve maximum strength.

Desk side chair in Twin Bedrooms #3 and #4 must meet the following specifications:

- AC Furniture Item # 1905 Fabric: Mainstream Mocha Finish: Figured Mahogany or equal;
- Dimensions must be between 17-19" W x 19-21" D x 30-32" H;
- Fabric must be Grade 3;
- Must have fully upholstered back and seat board;
- Must have mahogany stained finish;
- Upholstery fabrics must meet specifications Cal 117 Section E, BIFMA Class 1, UFAC Class 1 and NFPA 260 for flammability; and
- All stress points must be glued, double doweled and/or screwed to achieve maximum strength.

Twin Bed Bolster in Bedrooms #3 and #4 must meet the following specifications:

- AC Furniture Item # Custom construction, Fabric as specified in COM Fabriccut or equal;
- Minimum dimensions must be 37" W x 9" D x 11" H;
- Must be constructed as per bolster detail provided; and
- Must include bottom zipper.

Rocker/Recliner chair in living room must meet the following specifications:

- La-z-boy Anderson Reclina-Rocker, Item # 6010 Sloan/A949286, Color Indigo or equal;
- Minimum dimensions must be 33" W x 35" D x 40" H;
- Must be fully upholstered spring back and seat;
- Must be channel stitched;
- Must be tapered back; and
- Must be pillow arms.

Queen head board in bedrooms #1 & #2 must meet the following specifications:

- Kimball Hospitality Item # H16A0QH01A010C Finish: White Washed Maple or equal;
- Minimum dimensions must be 60" W x 1 5/8" D x 23" H; and
- Must have white washed maple stained finish.

Nightstand must meet the following specifications:

- Kimball Hospitality Item # H16A0NS01A010C Finish: White Washed Maple or equal;

DNR210240
Blackwater Falls State Park
Furnishings Purchase, Assembly and Installation

- Dimensions must be between 19-22" W x 20-23"D x 23-26" H;
- Must have white washed finish;
- Must have laminated top with matching high-pressure laminate that conforms to NEMA LD3; and
- All stress points must be glued, double doweled and/or screwed to achieve maximum strength.

Closet organizers must meet the following specifications:

- Each closet must have a minimum of two (2) 47-50" upright rails with hardware;
- Queen bedroom closets must have two (2) triple shelf units, minimum dimensions 22.87"w x 11.92d x 16.02h to accommodate studs in closet;
- Twin Bedroom closets must have one (1) 22.5"w x 17"d x 6"h medium slide out woven wood storage basket and one(1) 22.5"w x 17"d x 10"h large slide out woven wood storage basket to accommodate studs in closet;
- Rubbermaid Closet Organizer, Fast Track Upright Rail Item #62680 w/hardware or equal;
- Rubbermaid HomeFree Series accessories Triple Shelf White Item #94482 or equal;
- Rubbermaid Closet Organizer, Medium Slide Out Woven Storage Basket Item #3S05 or equal; and
- Rubbermaid Closet Organizer, Large Slide Out Woven Storage Basket Item #3S06 or equal.

Drapes, Hardware, Twin Bed Bolster Fabric and Bedspreads

All drapes except sheers shall be lined with Hospitality grade linings as per Fabricut standards or equal.

All drapes must be 2 ½ times stated width to produce required fullness for finished width.

Living Room Drapes and Hardware:

Must meet the following specifications:

- Fabricut Pattern: Velocity Color: Bluebell or equal;
- Must be 121"w x 69"h to accommodate window;
- Must 100 % polyester, exceeds 18,000 double rubs, wyzenbeek method;
- Must be machine wash dry;
- Must be hypo-allergenic;
- Must pass UFAC Class 1 for flamability;
- Must meet NFPA701 2004 for flamability;
- Must be cleaning code -S;
- 109" Hardware Center Draw baton;
- Must have 3" Return; and

DNR210240
Blackwater Falls State Park
Furnishings Purchase, Assembly and Installation

- Must be Pinch Pleat/thrifty

Front and Back Door Drapes:

Must meet the following specifications:

- Fabricut Pattern: Sheer Plaid-L Color: Butter or equal;
- Must be 24" x 40" to accommodate window;
- Must be Sheer panel;
- Must meet NFPA 701, 2004;
- Must be 100% polyester; and
- Must have 24" stationary fixed top and bottom commercial hardware.

Door Side Light Drapes must meet the following minimum specifications:

- Fabricut Pattern: Sheer Plaid-L Color: Butter or equal;
- Must be 10" x 40" to accommodate window;
- Must be Sheer panel;
- Must meet NFPA 701, 2004;
- Must be 100% polyester; and
- Must have 10" stationary fixed top and bottom commercial hardware.

Kitchen Window Drape and commercial hardware must meet the following specifications:

- Fabricut Pattern: Melody Color: Straw or equal;
- Must be 100" x 45" to accommodate window;
- Must be 100 % polyester;
- Must be machine wash, cleaning code -S;
- Must be hypo-allergenic;
- Must be OEKO Tex Standard 100 tested for harmful substances;
- Must pass NFPA701 2004;
- Must have 88" Hardware Center Draw baton;
- Must have 3" Return; and
- Must be Pinch Pleat/thrifty.

Bedroom #1 Drapes and commercial hardware must meet the following specifications:

- Fabricut Pattern: Elevation Color: Putty or equal;
- Must be 60"x69" to accommodate window;
- Must be 100 % polyester inherent FR;
- Must be OEKO Tex standard 100 tested for harmful substances;

DNR210240
Blackwater Falls State Park
Furnishings Purchase, Assembly and Installation

- Must pass ASTM-E84 test method for surface burning;
- Must pass NFPA701 2004;
- Must have 48" Hardware Center Draw baton;
- Must have 3" Return; and
- Must be Pinch Pleat/thrifty.

Bedroom #2 Drapes and commercial hardware must meet the following specifications:

- Fabricut Pattern: Awning Stripe Color: Putty or equal;
- Must be 60"x69" to accommodate window;
- Must be 100 % polyester inherent FR;
- Must be OEKO Tex standard 100 tested for harmful substances;
- Must pass ASTM-E84 test method for surface burning;
- Must pass NFPA701 2004;
- Must have 48" Hardware Center Draw baton;
- Must have 3" Return; and
- Must be Pinch Pleat/thrifty.

Bedroom #3 and Bedroom #4 Drapes and commercial hardware must meet the following specifications:

- Fabricut Pattern: Pulse, Color: Bayou or equal;
- Must be 60"x69" to accommodate window;
- Must be 100 % Recycled polyester;
- Must be Inherently flame retardant;
- Must pass NFPA701 2004;
- Must be machine washable;
- Must have 48" Hardware Center Draw baton;
- Must have 3" Return; and
- Must be Pinch Pleat/thrifty.

Queen Bedsread must meet the following specifications:

- Fabricut Pattern: Illustrate RxH, Color: Earth, Taupe Solidarity lining or equal;
- Minimum Fabric width 126" to minimum seams in spread;
- Must be 60"x80"x26" to accommodate queen mattress;
- Must be 100 % recycled polyester;
- Must be machine washable;
- Must be throw construction;
- Must be reverse sham;

DNR210240
Blackwater Falls State Park
Furnishings Purchase, Assembly and Installation

- Must be a minimum 8 oz. polyfil;
- Must be Box quilt with 26" drop;
- Must be OEKO Tex standard 100 tested for harmful substances;
- Must pass NFPA701 2004; and
- Bedspread lining must be 100% woven polyester FR.

Twin Bedspread must meet the following specifications:

- Fabricut Pattern: Pullman RXH, Color: Bayou, Taupe Solidarity lining or equal;
- Must be 38"x75"x26" to accommodate twin mattress;
- Must be 100 % recycled polyester;
- Must be machine washable;
- Must be throw construction;
- Must be a minimum 8 oz. polyfil;
- Must be Box quilt with 26" drop;
- Must be OEKO Tex standard 100 tested for harmful substances;
- Must pass NFPA701 2004 for flammability; and
- Bedspread lining must be 100% woven polyester FR.

COM Fabric for Twin Bed Bolster front, top and side must meet the following specifications:

- Fabricut Pattern: Zenith Color: Spa or equal;
- Must be a minimum of 6 yards for front, top and side of bolster;
- Must be 38% polyester, 31 % Cotton, 21 % Viscose, and 10 % Linen;
- Must be machine washable Cleaning Code – S;
- Must exceed 201,000 Double rubs Wyzenbee Method;
- Must be OEKO Tex Standard 100 tested for harmful substances; and
- Must meet UFAC Class 1.

COM Fabric for Twin Bed Bolster back, bottom and welt must meet the following specifications:

- Fabricut Pattern: Reliable Color: Spa or equal;
- Must be a minimum of 6 yards for back, bottom and welt of bolster;
- Must be 85% PVC Inherent FR and 15% Cotton Jersey;
- Must be washable Cleaning Code – W;
- Must exceed 201,000 Double rubs Wyzenbee Method;
- Must be OEKO Tex Standard 100 tested for harmful substances; and
- Must meet UFAC Class 1.

DNR210240
Blackwater Falls State Park
Furnishings Purchase, Assembly and Installation

Mirrors, Lighting, Wall Art and Accessories

All artwork and mirrors shall be provided with locking mounting devices suitable for drywall installation.

Living Room wall art must meet the following specifications:

- The Uttermost Co. Item #50992 Hope & Greens or equal;
- Wall art may be more than one piece;
- Minimum space dimensions must be 39" w x 1" d x 37" h;
- Maximum space dimensions are 96" w x 52" h; and
- Must be oil production with a brushstroke finish.

Dining Room lamp must meet the following specifications:

- The Uttermost Co. Item #29165 Peaceful or equal;
- Minimum dimensions must be 10" w x 10" d x 34" h;
- Must be rustic base with antiqued accents;
- Lamp shade to be silken textile; and
- Must be 60 watt.

Living Room lamp on guest table must meet the following specifications:

- The Uttermost Co. Item #26899 Baalon or equal;
- Minimum dimensions must be 11" w x 17" d x 28" h;
- Must have porcelain base;
- Must have rectangle bell shade in linen textile; and
- Must be 150 watt, 3-way socket.

Living Room lamp on end table must meet the following specifications:

- The Uttermost Co. Item #27754 Kennice or equal;
- Minimum dimensions must be 16" w x 9" d x 35" h;
- Must be porcelain body;
- Must have nickel plated accents;
- Must have rectangle bell shade in sueded textile; and
- Must be 100 watt, 3-way socket.

Entry foyer photo frame meet the following specifications:

DNR210240
Blackwater Falls State Park
Furnishings Purchase, Assembly and Installation

- The Uttermost Co. Item #13401 Simple Rules or equal;
- Minimum space dimensions are 20" w x 1" d x 34" h;
- Maximum space dimension are 24" w x 42" h;
- Must have aged finish; and
- Must hold seven photos.

Living room bookends meet the following specifications:

- The Uttermost Co. Item #19283 Wynfield Bookends or equal;
- Minimum dimensions for each bookend must be 8" w x 3" d x 8" h; and
- Must have antiqued finish.

Bedroom # 1 Night stand lamp must meet the following specifications:

- The Uttermost Co. Item #27862 Meena or equal;
- Minimum dimensions must be 15" w x 15" d x 29" h;
- Must have glass body with satin nickel metal detail;
- Must have silken hardback shade; and
- Must be 150 watt, 3-way socket.

Bedroom #1 table lamp must meet the following specifications:

- The Uttermost Co. Item #29118-1 Carrara or equal;
- Minimum dimensions must be 12" w x 8" d x 34" h;
- Must be antique silver leaf finished body;
- Must have rectangular, silken textile shade; and
- Must be 100 watt.

Bedroom #1 artwork over bed must meet the following specifications:

- The Uttermost Co. Item #41237 Essential I & II or equal;
- Wall art may be more than one piece;
- Minimum space dimensions are 48" w x 2" d x 27" h;
- Maximum space dimensions are 60" w x 48" h; and
- Must be double matted with linen outer mat.

Bedroom #1 mirror must meet the following specifications:

- The Uttermost Co. Item #12640 B Ogden Blue or equal;
- Minimum space dimensions are 27" w x 2" d x 37" h;

DNR210240
Blackwater Falls State Park
Furnishings Purchase, Assembly and Installation

- Maximum space dimensions are 48" w x 48" h;
- Must be wood frame with antiqued silver leaf details; and
- Mirror must have a minimum 1" bevel.

Bedroom # 2 Night stand lamp must meet the following specifications:

- The Uttermost Co. Item #29877 Bernadette or equal;
- Minimum dimensions must be 9" w x 9" d x 23" h;
- Must be crackled porcelain body with metal accents;
- Must have silken textile shade; and
- Must be 100 watt.

Bedroom #2 table lamp must meet the following specifications:

- The Uttermost Co. Item #29513-1 Angelita or equal;
- Minimum dimensions must be 8" w x 9" d x 36" h;
- Must be metal lamp with antiqued finish;
- Must have rectangular shade; and
- Must be 60 watt.

Bedroom #2 artwork over bed must meet the following specifications:

- The Uttermost Co. Item #50995 Branchessunr or equal;
- Wall art may be more than one piece;
- Minimum space dimensions are 50" w x 1" d x 25" h;
- Maximum space dimensions are 60" w x 48" h; and
- Frame must have distressing.

Bedroom #2 mirror must meet the following specifications:

- The Uttermost Co. Item #12320 B Hekman or equal;
- Minimum dimensions must be 25" w x 2" d x 29" h;
- Maximum space dimensions are 48" w x 48" h; and
- Must be minimum 3" wide wood frame with silver leaf finish.

Bedroom #3 and #4 table lamp must meet the following specifications:

- The Uttermost Co. Item #29104-1 Wrapped Spiral or equal;
- Minimum dimensions must be 12" w x 9" d x 38" h;
- Must be spiral metal lamp; and

DNR210240
Blackwater Falls State Park
Furnishings Purchase, Assembly and Installation

- Must be 100 watt, 3-way socket.

Bedroom #3 and #4 wall sconce lamp must meet the following specifications:

- The Uttermost Co. Item #22481 1-Light Wall Sconce Toffee Art Glass or equal;
- Minimum dimensions must be 6"w x 8"d x 14"h;
- Must be metal curled around art glass shade;
- Must be 100 watt; and
- Must be equipped with electric cord, on/off switch and 42" neutral colored wire molding for plug in.

Bedroom #3 and #4 mirror must meet the following specifications:

- The Uttermost Co. Item #14442 B Renzo or equal;
- Minimum space dimensions are 20"w x 2"d x 32"h;
- Maximum space dimensions are 48"w x 48"h;
- Frame must be distressed finish with gold leaf highlights; and
- Mirror must have a minimum 1" bevel.

BID SCHEDULE

Item No.	Quantity	Description	Unit Price	Amount
1	13	Sofa AC Furniture Item # 78003 or equal		
2	13	Love seat AC Furniture Item # 78002 or equal		
3	13	Guest Table AC Furniture Item # 130 or equal		
4	13	End Table AC Furniture Item # 4219 or equal		
5	13	Dining Room Trestle Table AC Furniture Item # 1778 or equal		
6	104	Dining Room Side Chair AC Furniture Item # 715 or equal		
7	39	Barstool AC Furniture Item # 693-Custom or equal		

DNR210240
Blackwater Falls State Park
Furnishings Purchase, Assembly and Installation

8	13	Sofa Table In Dining Room AC Furniture Item # 4240 or equal		
9	26	Sofa Table in Bedrooms 1 & 2 AC Furniture Item # 1440 or equal		
10	26	Sofa Table in Bedrooms 3 & 4 AC Furniture Item # 1140 or equal		
11	26	Lounge Chair in Bedrooms 1 & 2 AC Furniture Item # 9400 or equal		
12	26	Ottoman in Bedrooms 1 & 2 AC Furniture Item # 941 or equal		
13	26	Desk Chair in Bedrooms 3 & 4 AC Furniture Item # 1905 or equal		
14	52	Twin Bed Bolster in Bedrooms 3 & 4 AC Furniture Item # Custom construction or equal		
15	13	Rocker-Recliner La-z-boy Anderson Reclina-Rocker 6010 Sloan/A949286 or equal		
16	26	Queen Head Board Kimball Hospitality Item # H16A0QH01A010C or equal		
17	52	Night Stand Kimball Hospitality Item # H16A0NS01A010C or equal		
18	104	Rubbermaid Closet Organizer Fast Track Upright Rail Item # 62680 w/hardware or equal		
19	52	Rubbermaid Closet Organizer HomeFree Series Triple Shelf White Item # 94482 or equal		
20	26	Rubbermaid Closet Organizer Medium Slide Out Woven Storage Basket Item # 3S05 or equal		
21	26	Rubbermaid Closet Organizer Large Slide Out Woven Storage Basket Item # 3S06 or equal		
22	26	Living Room Drape 121" w x 69" h Fabricut or equal		
23	26	Front & Back Door Drape 24" w x 40" h Fabricut or equal		
24	39	Door Side Light Drape 10" w x 40" h Fabricut or equal		
25	13	Kitchen Window Drape 105" w x 45" h Fabricut or equal		
26	13	Bedroom #1 Drape 60" w x 69" h Fabricut or equal		

DNR210240
Blackwater Falls State Park
Furnishings Purchase, Assembly and Installation

27	13	Bedroom #2 Drape 60"w x 69"h Fabricut or equal		
28	26	Bedroom #3 & #4 Drape 60"w x 69"h Fabricut or equal		
29	78	Stationary Door Hardware 10"w Fabricut or equal		
30	52	Stationary Door Hardware 24"w Fabricut or equal		
31	13	Kitchen Drape Hardware 88"w Baton Draw/ Wall Mount/center open Fabricut or equal		
32	26	Living Room Drape Hardware 109"w Baton Draw/ Wall Mount/center open Fabricut or equal		
33	52	Bedroom Drape Hardware 48"w Baton Draw/ Wall Mount/center open Fabricut or equal		
34	78 yards	Custom Twin Bed Boster Fabric -Front COM Fabricut or equal		
35	78 yards	Custom Twin Bed Boster Fabric -Back COM Fabricut or equal		
36	30	Queen Bedspread Fabricut or equal		
37	56	Twin Bedspread Fabricut or equal		
38	13	Living Room Wall Art The Uttermost Co. Item # 50992 or equal		
39	13	Dining Room Lamp The Uttermost Co. Item # 29165 or equal		
40	13	Living Room Guest Table Lamp The Uttermost Co. Item # 26899 or equal		
41	13	Living Room End Table Lamp The Uttermost Co. Item # 27754 or equal		
42	13	Entry Foyer Picture Frame The Uttermost Co. Item # 13401 or equal		

DNR210240
Blackwater Falls State Park
Furnishings Purchase, Assembly and Installation

43	13	Living Room Bookends The Uttermost Co. Item #19283 or equal		
44	26	Bedroom #1 Night Stand Lamp The Uttermost Co. Item # 27862 or equal		
45	13	Bedroom #1 Table Lamp The Uttermost Co. Item # 29118-1 or equal		
46	13	Bedroom #1 Wall Art The Uttermost Co. Item # 41237 or equal		
47	13	Bedroom #1 Mirror The Uttermost Co. Item # 12640 B or equal		
48	26	Bedroom #2 Night Stand Lamp The Uttermost Co. Item #29827or equal		
49	13	Bedroom #2 Table Lamp The Uttermost Co. Item #29513-1 or equal		
50	13	Bedroom #2 Wall Art The Uttermost Co. Item # 50995 or equal		
51	13	Bedroom #2 Mirror The Uttermost Co. Item # 12320 B or equal		
52	26	Bedroom #3 & #4 Table Lamp The Uttermost Co. Item # 29104-1 or equal		
53	52	Bedroom #3 & #4 Wall Sconce The Uttermost Co. Item # 22481 or equal		
54	26	Bedroom #3 & #4 Mirror The Uttermost Co. Item # 14442 B or equal		
			GRAND TOTAL FURNISHINGS	\$

DNR210240
Blackwater Falls State Park
Furnishings Purchase, Assembly and Installation

OR EQUAL MANUFACTURER'S INFORMATION

Please complete the below information concerning the brand(s) of furnishings being bid in relation to this project if bidding or equal brands. Also attach manufacturer's literature documenting that it meets the mandatory requirements stated in the specifications. Vendors should note the areas of the provided manufacturer's literature that adheres to the mandatory requirements outlined in the Request of Quotation.

Item No.	Quantity	Product	Manufacturer	Model
1	13	Sofa AC Furniture Item # 78003 or equal		
2	13	Love seat AC Furniture Item # 78002 or equal		
3	13	Guest Table AC Furniture Item # 130 or equal		
4	13	End Table AC Furniture Item # 4219 or equal		
5	13	Dining Room Trestle Table AC Furniture Item # 1778 or equal		
6	104	Dining Room Side Chair AC Furniture Item # 715 or equal		
7	39	Barstool AC Furniture Item # 693-Custom or equal		
8	13	Sofa Table in Dining Room AC Furniture Item # 4240 or equal		
9	26	Sofa Table in Bedrooms 1 & 2 AC Furniture Item # 1440 or equal		
10	26	Sofa Table in Bedrooms 3 & 4 AC Furniture Item # 1140 or equal		
11	26	Lounge Chair in Bedrooms 1 & 2 AC Furniture Item # 9400 or equal		
12	26	Ottoman in Bedrooms 1 & 2 AC Furniture Item # 941 or equal		
13	26	Desk Chair in Bedrooms 3 & 4 AC Furniture Item # 1905 or equal		
14	52	Twin Bed Bolster in Bedrooms 3 & 4 AC Furniture Item # Custom construction or equal		
15	13	Rocker-Recliner La-z-boy Anderson Reclina-Rocker 6010 Sloan/A949286 or equal		

DNR210240
Blackwater Falls State Park
Furnishings Purchase, Assembly and Installation

16	26	Queen Head Board Kimball Hospitality Item # H16A0QH01A010C or equal		
17	52	Night Stand Kimball Hospitality Item # H16A0NS01A010C or equal		
18	104	Rubbermaid Closet Organizer Fast Track Upright Rail Item # 62680 w/hardware or equal		
19	52	Rubbermaid Closet Organizer HomeFree Series Triple Shelf White Item # 94482 or equal		
20	26	Rubbermaid Closet Organizer Medium Slide Out Woven Storage Basket Item # 3S05 or equal		
21	26	Rubbermaid Closet Organizer Large Slide Out Woven Storage Basket Item # 3S06 or equal		
22	26	Living Room Drape 121" w x 69" h Fabricut or equal		
23	26	Front & Back Door Drape 24" w x 40" h Fabricut or equal		
24	39	Door Side Light Drape 10" w x 40" h Fabricut or equal		
25	13	Kitchen Window Drape 105" w x 45" h Fabricut or equal		
26	13	Bedroom #1 Drape 60" w x 69" h Fabricut or equal		
27	13	Bedroom #2 Drape 60" w x 69" h Fabricut or equal		
28	26	Bedroom #3 & #4 Drape 60" w x 69" h Fabricut or equal		
29	78	Stationary Door Hardware 10" w Fabricut or equal		
30	52	Stationary Door Hardware 24" w Fabricut or equal		
31	13	Kitchen Drape Hardware 88" w Baton Draw/ Wall Mount/center open Fabricut or equal		
32	26	Living Room Drape Hardware 109" w Baton Draw/ Wall Mount/center open Fabricut or equal		
33	52	Bedroom Drape Hardware 48" w Baton Draw/ Wall Mount/center open Fabricut or equal		

DNR210240
Blackwater Falls State Park
Furnishings Purchase, Assembly and Installation

34	78 yards	Custom Twin Bed Boster Fabric -Front COM Fabricut or equal		
35	78 yards	Custom Twin Bed Boster Fabric -Back COM Fabricut or equal		
36	30	Queen Bedspread Fabricut or equal		
37	56	Twin Bedspread Fabricut or equal		
38	13	Living Room Wall Art The Uttermost Co. Item # 50992 or equal		
39	13	Dining Room Lamp The Uttermost Co. Item # 29165 or equal		
40	13	Living Room Guest Table Lamp The Uttermost Co. Item # 26899 or equal		
41	13	Living Room End Table Lamp The Uttermost Co. Item # 27754 or equal		
42	13	Entry Foyer Picture Frame The Uttermost Co. Item # 13401 or equal		
43	13	Living Room Bookends The Uttermost Co. Item #19283 or equal		
44	26	Bedroom #1 Night Stand Lamp The Uttermost Co. Item # 27862 or equal		
45	13	Bedroom #1 Table Lamp The Uttermost Co. Item # 29118-1 or equal		
46	13	Bedroom #1 Wall Art The Uttermost Co. Item # 41237 or equal		
47	13	Bedroom #1 Mirror The Uttermost Co. Item # 12640 B or equal		
48	26	Bedroom #2 Night Stand Lamp The Uttermost Co. Item #29827or equal		
49	13	Bedroom #2 Table Lamp The Uttermost Co. Item #29513-1 or equal		
50	13	Bedroom #2 Wall Art The Uttermost Co. Item # 50995 or equal		

DNR210240
Blackwater Falls State Park
Furnishings Purchase, Assembly and Installation

51	13	Bedroom #2 Mirror The Uttermost Co. Item # 12320 B or equal		
52	26	Bedroom #3 & #4 Table Lamp The Uttermost Co. Item # 29104-1 or equal		
53	52	Bedroom #3 & #4 Wall Sconce The Uttermost Co. Item # 22481 or equal		
54	26	Bedroom #3 & #4 Mirror The Uttermost Co. Item # 14442 B or equal		

DRAPERY SPECIFICATIONS

GENERAL CONSTRUCTION

All fabrics are commercially pattern matched.

Multiple width draperies are joined by overlock stitching. All half widths are positioned to be on the return side of the drapery. Side hems are blind stitched.

Draperies are manufactured to customer specifications with tolerances of +/- 1/2" in length and 1" increments in width.

Drapery linings are joined by overlocking and are finished with a 2 1/2" hem. Linings will hang 1 1/2" to 2" above the finished bottom of the drapery.

HEM AND HEADINGS

4" Single Headings	Pinch Pleated Lined Pinch Pleated Unlined
4" Double Headings	Sheer Draperies
4" Single Bottom Hem	Pinch Pleated Lined Pinch Pleated Unlined
4" Double Bottom Hem	Sheer Draperies
1.5" Double Side Hem	Pinch Pleated Lined Pinch Pleated Unlined

SPECIALTY ITEMS

Heading and Casing Draperies

Rod Pockets and bottom hems are manufactured as specified on each individual order.

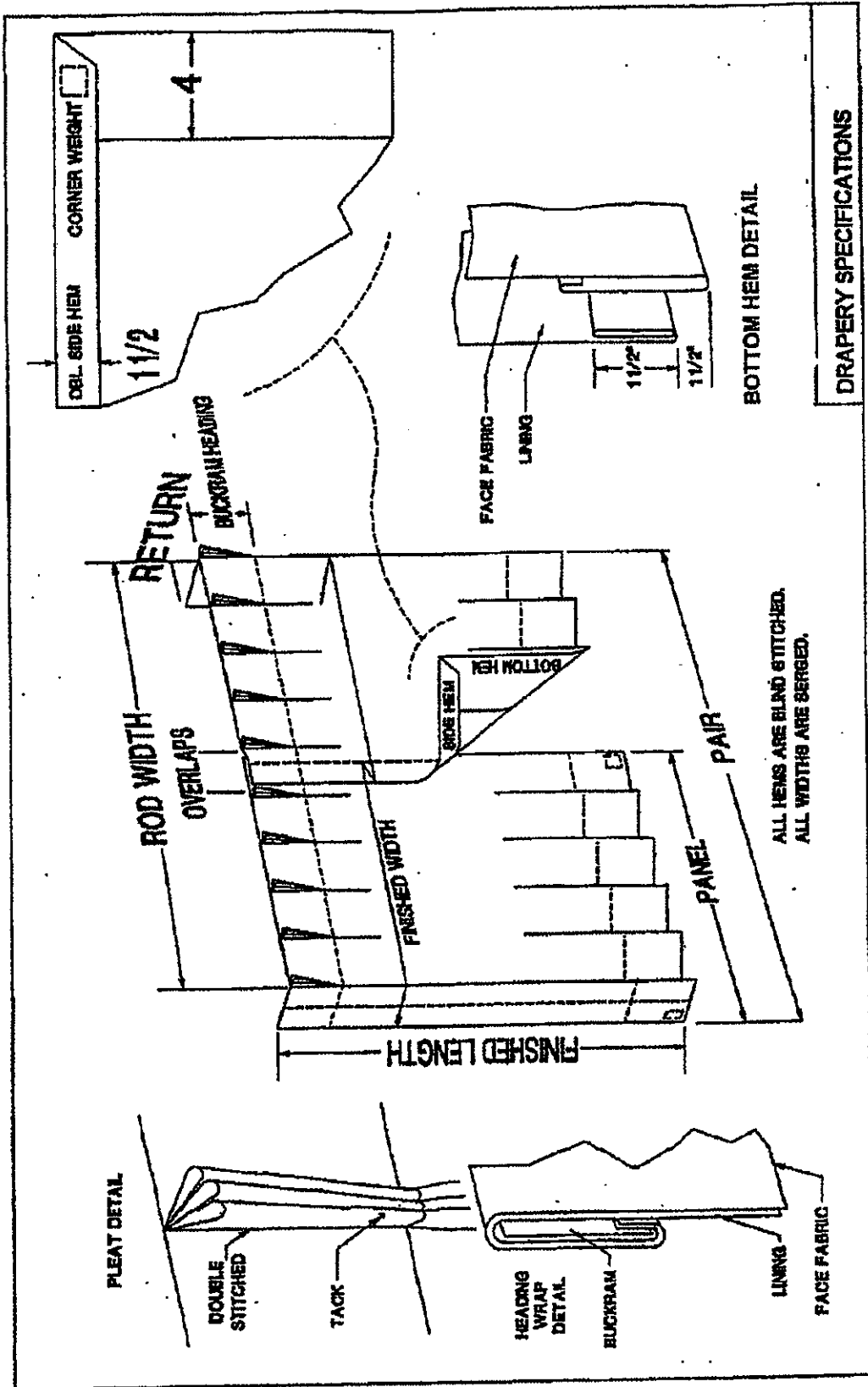

DRAPERY SPECIFICATIONS

Pinch Pleated Drapery

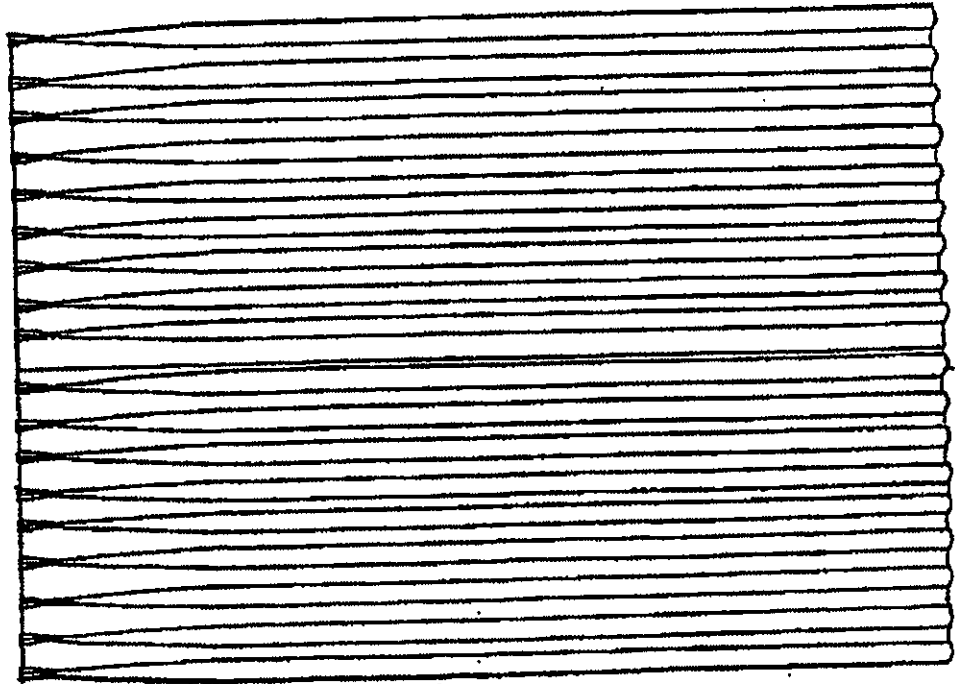

TWIN BED BOLESTER
DETAIL
INCLUDES BOTTOM
ZIPPER
FOR REMOVAL FOR
WASHING

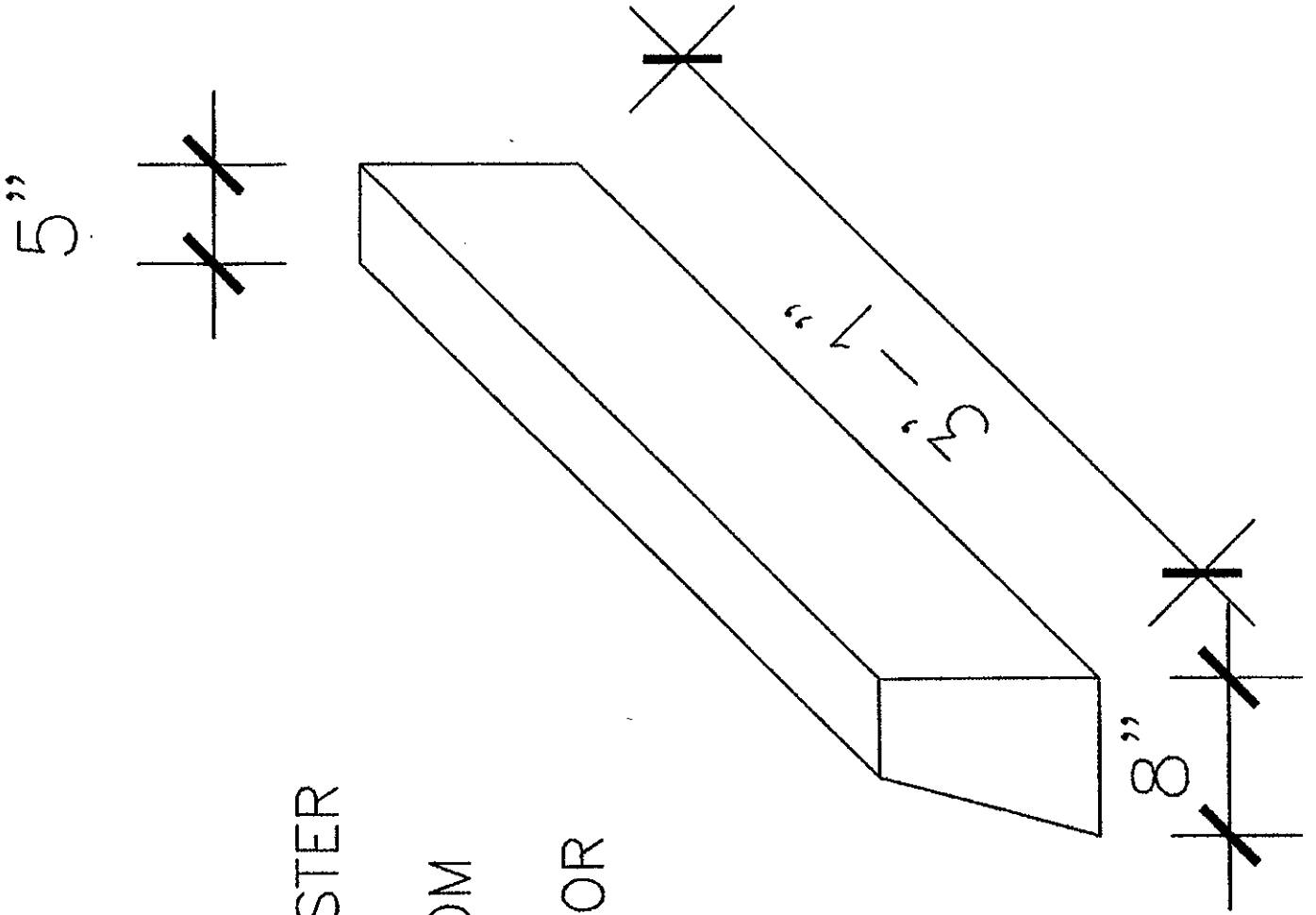

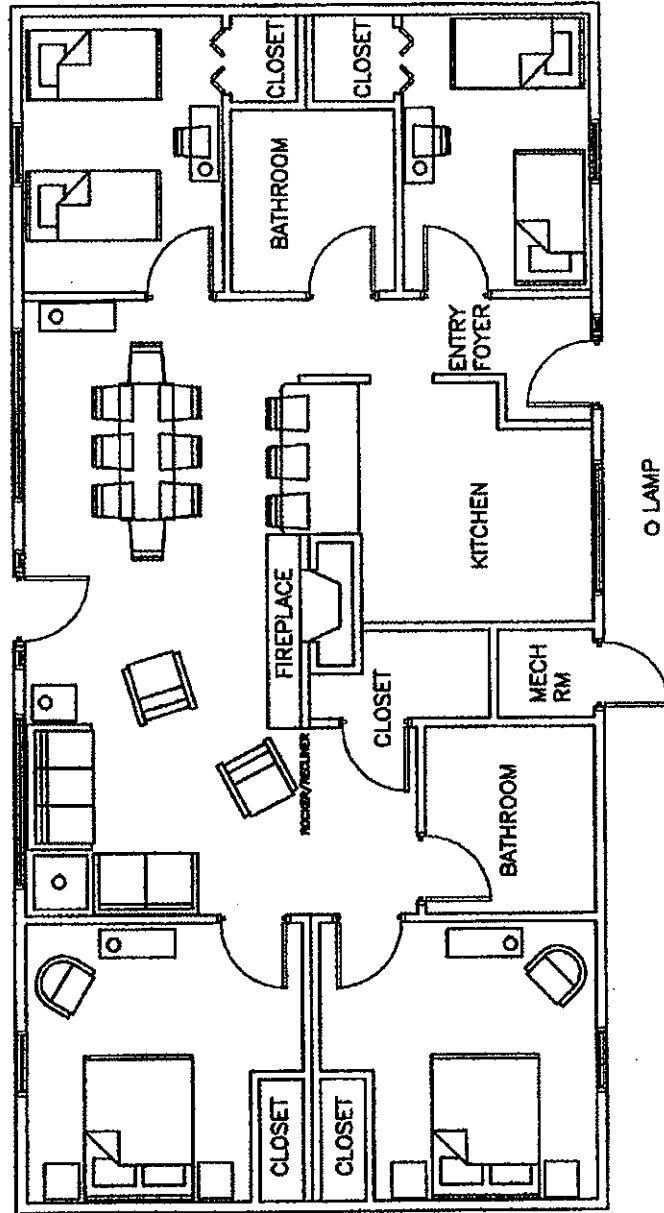

BLACKWATER FALL STATE PARK
CABIN FURNISHINGS PLAN
SCALE 1/8" = 1'

VENDOR PREFERENCE CERTIFICATE

Certification and application* is hereby made for Preference in accordance with *West Virginia Code*, §5A-3-37. (Does not apply to construction contracts). *West Virginia Code*, §5A-3-37, provides an opportunity for qualifying vendors to request (at the time of bid) preference for their residency status. Such preference is an evaluation method only and will be applied only to the cost bid in accordance with the *West Virginia Code*. This certificate for application is to be used to request such preference. The Purchasing Division will make the determination of the Resident Vendor Preference, if applicable.

1. Application is made for 2.5% resident vendor preference for the reason checked:

____ Bidder is an individual resident vendor and has resided continuously in West Virginia for four (4) years immediately preceding the date of this certification; **or,**

____ Bidder is a partnership, association or corporation resident vendor and has maintained its headquarters or principal place of business continuously in West Virginia for four (4) years immediately preceding the date of this certification; or 80% of the ownership interest of Bidder is held by another individual, partnership, association or corporation resident vendor who has maintained its headquarters or principal place of business continuously in West Virginia for four (4) years immediately preceding the date of this certification; **or,**

____ Bidder is a nonresident vendor which has an affiliate or subsidiary which employs a minimum of one hundred state residents and which has maintained its headquarters or principal place of business within West Virginia continuously for the four (4) years immediately preceding the date of this certification; **or,**

2. Application is made for 2.5% resident vendor preference for the reason checked:

____ Bidder is a resident vendor who certifies that, during the life of the contract, on average at least 75% of the employees working on the project being bid are residents of West Virginia who have resided in the state continuously for the two years immediately preceding submission of this bid; **or,**

3. Application is made for 2.5% resident vendor preference for the reason checked:

____ Bidder is a nonresident vendor employing a minimum of one hundred state residents or is a nonresident vendor with an affiliate or subsidiary which maintains its headquarters or principal place of business within West Virginia employing a minimum of one hundred state residents who certifies that, during the life of the contract, on average at least 75% of the employees or Bidder's affiliate's or subsidiary's employees are residents of West Virginia who have resided in the state continuously for the two years immediately preceding submission of this bid; **or,**

4. Application is made for 5% resident vendor preference for the reason checked:

____ Bidder meets either the requirement of both subdivisions (1) and (2) or subdivision (1) and (3) as stated above; **or,**

5. Application is made for 3.5% resident vendor preference who is a veteran for the reason checked:

____ Bidder is an individual resident vendor who is a veteran of the United States armed forces, the reserves or the National Guard and has resided in West Virginia continuously for the four years immediately preceding the date on which the bid is submitted; **or,**

6. Application is made for 3.5% resident vendor preference who is a veteran for the reason checked:

____ Bidder is a resident vendor who is a veteran of the United States armed forces, the reserves or the National Guard, if, for purposes of producing or distributing the commodities or completing the project which is the subject of the vendor's bid and continuously over the entire term of the project, on average at least seventy-five percent of the vendor's employees are residents of West Virginia who have resided in the state continuously for the two immediately preceding years.

Bidder understands if the Secretary of Revenue determines that a Bidder receiving preference has failed to continue to meet the requirements for such preference, the Secretary may order the Director of Purchasing to: (a) reject the bid; or (b) assess a penalty against such Bidder in an amount not to exceed 5% of the bid amount and that such penalty will be paid to the contracting agency or deducted from any unpaid balance on the contract or purchase order.

By submission of this certificate, Bidder agrees to disclose any reasonably requested information to the Purchasing Division and authorizes the Department of Revenue to disclose to the Director of Purchasing appropriate information verifying that Bidder has paid the required business taxes, provided that such information does not contain the amounts of taxes paid nor any other information deemed by the Tax Commissioner to be confidential.

Under penalty of law for false swearing (West Virginia Code, §61-5-3), Bidder hereby certifies that this certificate is true and accurate in all respects; and that if a contract is issued to Bidder and if anything contained within this certificate changes during the term of the contract, Bidder will notify the Purchasing Division in writing immediately.

Bidder: _____

Signed: _____

Date: _____

Title: _____

*Check any combination of preference consideration(s) indicated above, which you are entitled to receive.

STATE OF WEST VIRGINIA
Purchasing Division

PURCHASING AFFIDAVIT

West Virginia Code §5A-3-10a states: No contract or renewal of any contract may be awarded by the state or any of its political subdivisions to any vendor or prospective vendor when the vendor or prospective vendor or a related party to the vendor or prospective vendor is a debtor and the debt owed is an amount greater than one thousand dollars in the aggregate.

DEFINITIONS:

"Debt" means any assessment, premium, penalty, fine, tax or other amount of money owed to the state or any of its political subdivisions because of a judgment, fine, permit violation, license assessment, defaulted workers' compensation premium, penalty or other assessment presently delinquent or due and required to be paid to the state or any of its political subdivisions, including any interest or additional penalties accrued thereon.

"Debtor" means any individual, corporation, partnership, association, limited liability company or any other form or business association owing a debt to the state or any of its political subdivisions. "Political subdivision" means any county commission; municipality; county board of education; any instrumentality established by a county or municipality; any separate corporation or instrumentality established by one or more counties or municipalities, as permitted by law; or any public body charged by law with the performance of a government function or whose jurisdiction is coextensive with one or more counties or municipalities. "Related party" means a party, whether an individual, corporation, partnership, association, limited liability company or any other form or business association or other entity whatsoever, related to any vendor by blood, marriage, ownership or contract through which the party has a relationship of ownership or other interest with the vendor so that the party will actually or by effect receive or control a portion of the benefit, profit or other consideration from performance of a vendor contract with the party receiving an amount that meets or exceed five percent of the total contract amount.

EXCEPTION: The prohibition of this section does not apply where a vendor has contested any tax administered pursuant to chapter eleven of this code, workers' compensation premium, permit fee or environmental fee or assessment and the matter has not become final or where the vendor has entered into a payment plan or agreement and the vendor is not in default of any of the provisions of such plan or agreement.

Under penalty of law for false swearing (*West Virginia Code §61-5-3*), it is hereby certified that the vendor affirms and acknowledges the information in this affidavit and is in compliance with the requirements as stated.

WITNESS THE FOLLOWING SIGNATURE

Vendor's Name: _____

Authorized Signature: _____ Date: _____

State of _____

County of _____, to-wit:

Taken, subscribed, and sworn to before me this ____ day of _____, 20____.

My Commission expires _____, 20____.

AFFIX SEAL HERE

NOTARY PUBLIC _____