



State of West Virginia
 Department of Administration
 Purchasing Division
 2019 Washington Street East
 Post Office Box 50130
 Charleston, WV 25305-0130

Request for Quotation

RFQ NUMBER
 09110224

PAGE
 1

ADDRESS CORRESPONDENCE TO ATTENTION OF
 BUYER 33
 304-558-2402

VENDOR

RFQ COPY
 TYPE NAME/ADDRESS HERE

SHIP TO

DIVISION OF HIGHWAYS
 DISTRICT NINE
 103 1/2 CHURCH STREET
 LEWISBURG, WV
 24901 304-647-7457

| DATE PRINTED | TERMS OF SALE | SHIP VIA | F.O.B. | FREIGHT TERMS |
|--------------|---------------|----------|--------|---------------|
| 11/19/2010 | | | | |

BID OPENING DATE: 12/09/2010 BID OPENING TIME 01:30PM

| LINE | QUANTITY | UOP | CAT NO | ITEM NUMBER | UNIT PRICE | AMOUNT |
|--|----------|-----|--------|-------------|------------|--------|
| 0001 | 1 | JB | | 988-15 | | |
| CHAIN LINK FENCE MATERIAL AND INSTALLATION | | | | | | |
| REQUEST FOR QUOTATION (RFQ) | | | | | | |
| <p>THE WEST VIRGINIA STATE PURCHASING DIVISION FOR THE AGENCY, THE WEST VIRGINIA DIVISION OF HIGHWAY, IS SOLICITING BIDS TO FURNISH MATERIAL AND INSTALLATION OF 1417 LINEAL FEET OF HEAVY CHAIN LINK FENCE PER THE ATTACHED SPECIFICATIONS.</p> <p>TECHNICAL QUESTIONS CONCERNING THIS SOLICITATION MUST BE SUBMITTED IN WRITING TO SHERI SLONE IN THE WEST VIRGINIA STATE PURCHASING DIVISION VIA MAIL AT THE ADDRESS SHOWN IN THE BODY OF THIS RFQ, VIA FAX AT 304-558-2596, OR VIA EMAIL AT SHERI.D.SLONE@WV.GOV. DEADLINE FOR ALL TECHNICAL QUESTIONS IS 12/02/2010 AT THE CLOSE OF BUSINESS. ANY TECHNICAL QUESTIONS RECEIVED WILL BE ANSWERED BY FORMAL ADDENDUM TO BE ISSUED BY THE PURCHASING DIVISION AFTER THE DEADLINE HAS LAPSED.</p> <p>EXHIBIT 5</p> <p>WEST VIRGINIA CODE 21-1D-5 PROVIDES THAT: ANY SOLICITATION FOR A PUBLIC IMPROVEMENT CONSTRUCTION CONTRACT REQUIRES EACH VENDOR THAT SUBMITS A BID FOR THE WORK TO SUBMIT AT THE SAME TIME AN AFFIDAVIT OF COMPLIANCE WITH THE BID. THE ENCLOSED DRUG-FREE WORKPLACE AFFIDAVIT</p> | | | | | | |

| | | | | | | |
|---|--|------|-----------|-----------------------------------|------|--|
| SEE REVERSE SIDE FOR TERMS AND CONDITIONS | | | | | | |
| SIGNATURE | | | TELEPHONE | | DATE | |
| TITLE | | FEIN | | ADDRESS CHANGES TO BE NOTED ABOVE | | |

WHEN RESPONDING TO RFQ, INSERT NAME AND ADDRESS IN SPACE ABOVE LABELED 'VENDOR'

GENERAL TERMS & CONDITIONS REQUEST FOR QUOTATION (RFQ) AND REQUEST FOR PROPOSAL (RFP)

1. Awards will be made in the best interest of the State of West Virginia.
2. The State may accept or reject in part, or in whole, any bid.
3. Prior to any award, the apparent successful vendor must be properly registered with the Purchasing Division and have paid the required \$125 fee.
4. All services performed or goods delivered under State Purchase Order/Contracts are to be continued for the term of the Purchase Order/Contracts, contingent upon funds being appropriated by the Legislature or otherwise being made available. In the event funds are not appropriated or otherwise available for these services or goods this Purchase Order/Contract becomes void and of no effect after June 30.
5. Payment may only be made after the delivery and acceptance of goods or services.
6. Interest may be paid for late payment in accordance with the *West Virginia Code*.
7. Vendor preference will be granted upon written request in accordance with the *West Virginia Code*.
8. The State of West Virginia is exempt from federal and state taxes and will not pay or reimburse such taxes.
9. The Director of Purchasing may cancel any Purchase Order/Contract upon 30 days written notice to the seller.
10. The laws of the State of West Virginia and the *Legislative Rules* of the Purchasing Division shall govern the purchasing process.
11. Any reference to automatic renewal is hereby deleted. The Contract may be renewed only upon mutual written agreement of the parties.
12. **BANKRUPTCY:** In the event the vendor/contractor files for bankruptcy protection, the State may deem this contract null and void, and terminate such contract without further order.
13. **HIPAA BUSINESS ASSOCIATE ADDENDUM:** The West Virginia State Government HIPAA Business Associate Addendum (BAA), approved by the Attorney General, is available online at www.state.wv.us/admin/purchase/vrc/hipaa.htm and is hereby made part of the agreement. Provided that the Agency meets the definition of a Cover Entity (45 CFR §160.103) and will be disclosing Protected Health Information (45 CFR §160.103) to the vendor.
14. **CONFIDENTIALITY:** The vendor agrees that he or she will not disclose to anyone, directly or indirectly, any such personally identifiable information or other confidential information gained from the agency, unless the individual who is the subject of the information consents to the disclosure in writing or the disclosure is made pursuant to the agency's policies, procedures, and rules. Vendor further agrees to comply with the Confidentiality Policies and Information Security Accountability Requirements, set forth in <http://www.state.wv.us/admin/purchase/privacy/noticeConfidentiality.pdf>.
15. **LICENSING:** Vendors must be licensed and in good standing in accordance with any and all state and local laws and requirements by any state or local agency of West Virginia, including, but not limited to, the West Virginia Secretary of State's Office, the West Virginia Tax Department, and the West Virginia Insurance Commission. The vendor must provide all necessary releases to obtain information to enable the director or spending unit to verify that the vendor is licensed and in good standing with the above entities.
16. **ANTITRUST:** In submitting a bid to any agency for the State of West Virginia, the bidder offers and agrees that if the bid is accepted the bidder will convey, sell, assign or transfer to the State of West Virginia all rights, title and interest in and to all causes of action it may now or hereafter acquire under the antitrust laws of the United States and the State of West Virginia for price fixing and/or unreasonable restraints of trade relating to the particular commodities or services purchased or acquired by the State of West Virginia. Such assignment shall be made and become effective at the time the purchasing agency tenders the initial payment to the bidder.

I certify that this bid is made without prior understanding, agreement, or connection with any corporation, firm, limited liability company, partnership, or person or entity submitting a bid for the same material, supplies, equipment or services and is in all respects fair and without collusion or Fraud. I further certify that I am authorized to sign the certification on behalf of the bidder or this bid.

INSTRUCTIONS TO BIDDERS

1. Use the quotation forms provided by the Purchasing Division. Complete all sections of the quotation form.
2. Items offered must be in compliance with the specifications. Any deviation from the specifications must be clearly indicated by the bidder. Alternates offered by the bidder as **EQUAL** to the specifications must be clearly defined. A bidder offering an alternate should attach complete specifications and literature to the bid. The Purchasing Division may waive minor deviations to specifications.
3. Unit prices shall prevail in case of discrepancy. All quotations are considered F.O.B. destination unless alternate shipping terms are clearly identified in the quotation.
4. All quotations must be delivered by the bidder to the office listed below prior to the date and time of the bid opening. Failure of the bidder to deliver the quotations on time will result in bid disqualifications: Department of Administration, Purchasing Division, 2019 Washington Street East, P.O. Box 50130, Charleston, WV 25305-0130
5. Communication during the solicitation, bid, evaluation or award periods, except through the Purchasing Division, is strictly prohibited (W.Va. C.S.R. §148-1-6.6).



State of West Virginia
 Department of Administration
 Purchasing Division
 2019 Washington Street East
 Post Office Box 50130
 Charleston, WV 25305-0130

Request for Quotation

| |
|------------|
| RFQ NUMBER |
| 09110224 |

| |
|------|
| PAGE |
| 2 |

| |
|--|
| ADDRESS CORRESPONDENCE TO ATTENTION OF |
| BUYER 33 304-558-2402 |

| | |
|--------|------------------------|
| VENDOR | RFQ COPY |
| | TYPE NAME/ADDRESS HERE |

| | |
|---------|--|
| SHIP TO | DIVISION OF HIGHWAYS DISTRICT NINE |
| | 103 1/2 CHURCH STREET LEWISBURG, WV 24901 304-647-7457 |

| DATE PRINTED | TERMS OF SALE | SHIP VIA | F.O.B. | FREIGHT TERMS |
|--------------|---------------|----------|--------|---------------|
| 11/19/2010 | | | | |

BID OPENING DATE: 12/09/2010 BID OPENING TIME 01:30PM

| LINE | QUANTITY | UOP | CAT NO | ITEM NUMBER | UNIT PRICE | AMOUNT |
|--|----------|-----|--------|-------------|------------|--------|
| <p>MUST BE SIGNED AND SUBMITTED WITH THE BID AS EVIDENCE OF THE VENDOR'S COMPLIANCE WITH THE PROVISIONS OF ARTICLE 1D, CHAPTER 21 OF THE WEST VIRGINIA CODE. FAILURE TO SUBMIT THE SIGNED DRUG-FREE WORKPLACE AFFIDAVIT WITH THE BID SHALL RESULT IN DISQUALIFICATION OF SUCH BID.</p> <p>NOTICE TO PROCEED: THIS CONTRACT IS TO BE PERFORMED WITHIN 30 CALENDAR DAYS AFTER THE NOTICE TO PROCEED IS RECEIVED. UNLESS OTHERWISE SPECIFIED, THE FULLY EXECUTED PURCHASE ORDER WILL BE CONSIDERED NOTICE TO PROCEED.</p> <p>CANCELLATION: THE DIRECTOR OF PURCHASING RESERVES THE RIGHT TO CANCEL THIS CONTRACT IMMEDIATELY UPON WRITTEN NOTICE TO THE VENDOR IF THE MATERIALS OR WORKMANSHIP SUPPLIED ARE OF AN INFERIOR QUALITY OR DO NOT CONFORM WITH THE SPECIFICATIONS OF THE BID AND CONTRACT HERE IN.</p> <p>WAGE RATES: THE CONTRACTOR OR SUBCONTRACTOR SHALL PAY THE HIGHER OF THE U.S. DEPARTMENT OF LABOR MINIMUM WAGE RATES AS ESTABLISHED FOR MONROE COUNTY, PURSUANT TO WEST VIRGINIA CODE 21-5A, ET, SEQ. (PREVAILING WAGE RATES APPLY TO THIS PROJECT)</p> <p>ARBITRATION: ANY REFERENCES MADE TO ARBITRATION OR INTEREST FOR PAYMENTS DUE (EXCEPT FOR ANY INTEREST REQUIRED BY STATE LAW) CONTAINED IN THIS CONTRACT OR IN ANY AMERICAN INSTITUTE OF ARCHITECTS DOCUMENTS PERTAINING TO THIS CONTRACT ARE HEREBY DELETED.</p> <p>WORKERS' COMPENSATION: VENDOR IS REQUIRED TO PROVIDE A CERTIFICATE FROM WORKERS' COMPENSATION IF SUCCESSFUL.</p> <p>ALL OF THE ITEMS CHECKED BELOW WILL BE A REQUIREMENT OF THIS CONTRACT:</p> | | | | | | |

SEE REVERSE SIDE FOR TERMS AND CONDITIONS

| | | |
|-----------|-----------|-----------------------------------|
| SIGNATURE | TELEPHONE | DATE |
| TITLE | FEIN | ADDRESS CHANGES TO BE NOTED ABOVE |

WHEN RESPONDING TO RFQ. INSERT NAME AND ADDRESS IN SPACE ABOVE LABELED 'VENDOR'



State of West Virginia
 Department of Administration
 Purchasing Division
 2019 Washington Street East
 Post Office Box 50130
 Charleston, WV 25305-0130

Request for Quotation

RFQ NUMBER
 09110224

PAGE
 3

ADDRESS CORRESPONDENCE TO ATTENTION OF
 BUYER 33
 304-558-2402

RFQ COPY

TYPE NAME/ADDRESS HERE

V
E
N
D
O
R

S
H
I
P
T
O

DIVISION OF HIGHWAYS
 DISTRICT NINE
 103 1/2 CHURCH STREET
 LEWISBURG, WV
 24901 304-647-7457

| DATE PRINTED | TERMS OF SALE | SHIP VIA | FOB | FREIGHT TERMS |
|--------------|---------------|----------|-----|---------------|
| 11/19/2010 | | | | |

BID OPENING DATE: 12/09/2010 BID OPENING TIME 01:30PM

| LINE | QUANTITY | UOP | CAT NO | ITEM NUMBER | UNIT PRICE | AMOUNT |
|---|----------|-----|--------|-------------|------------|--------|
| <p>(XX) INSURANCE: SUCCESSFUL VENDOR SHALL FURNISH PROOF OF COMMERCIAL GENERAL LIABILITY INSURANCE PRIOR TO ISSUANCE OF CONTRACT. UNLESS OTHERWISE SPECIFIED IN THE BID DOCUMENTS, THE MINIMUM AMOUNT OF INSURANCE COVERAGE REQUIRED IS \$250,000.</p> <p>() BUILDERS RISK INSURANCE: SUCCESSFUL VENDOR SHALL FURNISH PROOF OF BUILDERS RISK - ALL RISK INSURANCE IN AN AMOUNT EQUAL TO 100% OF THE AMOUNT OF THE CONTRACT.</p> <p>(XX) BONDS: FIVE PERCENT (5%) OF THE TOTAL AMOUNT OF THE BID PAYABLE TO THE STATE OF WEST VIRGINIA, SHALL BE SUBMITTED WITH EACH BID AS A BID BOND. THE SUCCESSFUL BIDDER SHALL ALSO FURNISH A PERFORMANCE BOND AND LABOR/MATERIAL BOND FOR 100% OF THE AMOUNT OF THE CONTRACT. BONDS MAY BE PROVIDED IN THE FORM OF A CERTIFIED CHECK, IRREVOCABLE LETTER OF CREDIT, OR BOND FURNISHED BY A SOLVENT SURETY COMPANY AUTHORIZED TO DO BUSINESS IN THE STATE OF WEST VIRGINIA. A LETTER OF CREDIT SUBMITTED IN LIEU OF A BOND WILL ONLY BE ALLOWED FOR PROJECTS UNDER \$100,000. PERSONAL OR BUSINESS CHECKS ARE NOT ACCEPCTABLE IN LIEU OF THE 5% BID BOND, PERFORMANCE BOND, OR LABOR AND MATERIAL BOND.</p> <p>() MAINTENANCE BOND: A TWO (2) YEAR MAINTENANCE BOND COVERING THE ROOFING SYSTEM WILL BE A REQUIREMENT OF THE SUCCESSFUL VENDOR.</p> <p>REV. 11/00</p> <p>EXHIBIT 7</p> <p>DOMESTIC ALUMINUM, GLASS & STEEL IN PUBLIC WORKS PROJECTS</p> | | | | | | |

SEE REVERSE SIDE FOR TERMS AND CONDITIONS

| | | |
|-----------|-----------|-----------------------------------|
| SIGNATURE | TELEPHONE | DATE |
| TITLE | FEIN | ADDRESS CHANGES TO BE NOTED ABOVE |

WHEN RESPONDING TO RFQ, INSERT NAME AND ADDRESS IN SPACE ABOVE LABELED 'VENDOR'



State of West Virginia
 Department of Administration
 Purchasing Division
 2019 Washington Street East
 Post Office Box 50130
 Charleston, WV 25305-0130

Request for Quotation

RFQ NUMBER
 09110224

PAGE
 4

ADDRESS CORRESPONDENCE TO ATTENTION OF
 BUYER 33
 304-558-2402

VENDOR

RFQ COPY
 TYPE NAME/ADDRESS HERE

SHIP TO

DIVISION OF HIGHWAYS
 DISTRICT NINE
 103 1/2 CHURCH STREET
 LEWISBURG, WV
 24901 304-647-7457

| DATE PRINTED | TERMS OF SALE | SHIP VIA | FOB | FREIGHT TERMS |
|--------------|---------------|----------|-----|---------------|
| 11/19/2010 | | | | |

BID OPENING DATE: 12/09/2010 BID OPENING TIME 01:30PM

| LINE | QUANTITY | UOP | CAT NO | ITEM NUMBER | UNIT PRICE | AMOUNT |
|--|----------|-----|--------|-------------|------------|--------|
| <p>IN ACCORDANCE WITH WEST VIRGINIA CODE 5-19-1 ET., SEQ., EVERY CONTRACT FOR CONSTRUCTION, RECONSTRUCTION, ALTERATION, REPAIR, IMPROVEMENT OR MAINTENANCE OF PUBLIC WORKS, WHERE THE COST IS MORE THAN \$50,000 AND, IN THE CASE OF STEEL ONLY, WHERE THE COST OF STEEL IS MORE THAN \$50,000 OR WHERE MORE THAN 10,000 POUNDS OF STEEL ARE REQUIRED, THE STATE WILL ACCEPT ONLY ALUMINUM GLASS, OR STEEL PRODUCTS PRODUCED IN THE UNITED STATES. IN ADDITION, ITEMS OF MACHINERY OR EQUIPMENT PURCHASED FOR USE AT THE SITE OF PUBLIC WORKS SHALL BE MADE OF DOMESTIC ALUMINUM, GLASS OR STEEL, UNLESS THE COST OF THE PRODUCT IS LESS THAN \$50,000 OR LESS THAN 10,000 POUNDS OF STEEL ARE USED IN PUBLIC WORKS PROJECTS.</p> <p>FOREIGN MADE ALUMINUM, GLASS OR STEEL PRODUCTS MAY BE ACCEPTED ONLY IF THE COST OF DOMESTIC PRODUCTS IS FOUND TO BE UNREASONABLE. SUCH COST IS UNREASONABLE IF IT IS 20% OR MORE HIGHER THAN THE BID PRICE FOR FOREIGN MADE PRODUCTS. IF THE DOMESTIC ALUMINUM, GLASS OR STEEL PRODUCTS TO BE SUPPLIED OR PRODUCED IN A "SUBSTANTIAL LABOR SURPLUS AREA", AS DEFINED BY THE UNITED STATES DEPARTMENT OF LABOR, FOREIGN PRODUCTS MAY BE SUPPLIED ONLY IF DOMESTIC PRODUCTS ARE 30% OR MORE HIGHER IN PRICE THAN THE FOREIGN MADE PRODUCTS.</p> <p>IF, PRIOR TO THE AWARD OF A CONTRACT UNDER THE ABOVE PROVISIONS, THE SPENDING OFFICER OF THE SPENDING UNIT DETERMINES THAT THERE EXISTS A BID FOR LIKE FOREIGN ALUMINUM, GLASS OR STEEL THAT IS REASONABLE AND LOWER THAN THE LOWEST BID DOMESTIC PRODUCTS, THE SPENDING OFFICE MAY REQUEST, IN WRITING, A REEVALUATION AND REDUCTION IN THE LOWEST BID FOR SUCH DOMESTIC PRODUCTS. ALL VENDORS MUST INDICATE IN THEIR BID IF THEY ARE SUPPLYING FOREIGN ALUMINUM, GLASS OR STEEL.</p> | | | | | | |

SEE REVERSE SIDE FOR TERMS AND CONDITIONS

| | | |
|-----------|-----------|-----------------------------------|
| SIGNATURE | TELEPHONE | DATE |
| TITLE | FEIN | ADDRESS CHANGES TO BE NOTED ABOVE |

WHEN RESPONDING TO RFQ, INSERT NAME AND ADDRESS IN SPACE ABOVE LABELED 'VENDOR'



State of West Virginia
 Department of Administration
 Purchasing Division
 2019 Washington Street East
 Post Office Box 50130
 Charleston, WV 25305-0130

Request for Quotation

RFQ NUMBER
 09110224

PAGE
 5

ADDRESS CORRESPONDENCE TO ATTENTION OF
 BUYER 33
 304-558-2402

RFQ COPY
 TYPE NAME/ADDRESS HERE

DIVISION OF HIGHWAYS
 DISTRICT NINE
 103 1/2 CHURCH STREET
 LEWISBURG, WV
 24901 304-647-7457

| DATE PRINTED | TERMS OF SALE | SHIP VIA | F.O.B | FREIGHT TERMS |
|------------------------------|---------------|--------------------------|-------|---------------|
| 11/19/2010 | | | | |
| BID OPENING DATE: 12/09/2010 | | BID OPENING TIME 01:30PM | | |

| LINE | QUANTITY | UCP | CAT. NO. | ITEM NUMBER | UNIT PRICE | AMOUNT |
|---|----------|-----|----------|-------------|------------|--------|
| REV. 3/88 | | | | | | |
| EXHIBIT 9 | | | | | | |
| NOTICE FOR ISSUANCE & ACKNOWLEDGEMENT OF CONSTRUCTION PROJECT ADDENDA THE ARCHITECT/ENGINEER AND/OR AGENCY SHALL BE REQUIRED TO ABIDE BY THE FOLLOWING SCHEDULE IN ISSUING CONSTRUCTION PROJECT ADDENDA FOR STATE AGENCIES: (1) THE ARCHITECT/ENGINEER SHALL PREPARE THE ADDENDUM AND A LIST OF ALL PARTIES THAT HAVE PROCURED DRAWINGS AND SPECIFICATIONS FOR THE PROJECT. THE ADDENDUM AND LIST SHALL BE FORWARDED TO THE BUYER IN THE STATE PURCHASING DIVISION. THE ARCHITECT/ENGINEER SHALL ALSO SEND A COPY OF THE ADDENDUM TO THE STATE AGENCY FOR WHICH THE CONTRACT IS ISSUED. (2) THE BUYER SHALL SEND THE ADDENDUM TO ALL INTERESTED PARTIES AND, IF NECESSARY, EXTEND THE BID OPENING DATE. ANY ADDENDUM SHOULD BE RECEIVED BY THE BUYER WITHIN FOURTEEN (14) DAYS PRIOR TO THE BID OPENING DATE. (3) ALL ADDENDA SHOULD BE FORMALLY ACKNOWLEDGED BY ALL BIDDERS AND SUBMITTED TO THE STATE PURCHASING DIVISION. THE SAME RULES AND REGULATIONS THAT APPLY TO THE ORIGINAL BIDDING DOCUMENT SHALL ALSO APPLY TO AN ADDENDUM DOCUMENT. THE ONLY EXCEPTION MAY BE FOR AN ADDENDUM THAT IS ISSUED FOR THE SOLE PURPOSE OF CHANGING A BID OPENING TIME AND/OR DATE. | | | | | | |
| REV. 11/96 | | | | | | |

SEE REVERSE SIDE FOR TERMS AND CONDITIONS

| | | |
|-----------|-----------|-----------------------------------|
| SIGNATURE | TELEPHONE | DATE |
| TITLE | FEIN | ADDRESS CHANGES TO BE NOTED ABOVE |

WHEN RESPONDING TO RFQ INSERT NAME AND ADDRESS IN SPACE ABOVE LABELLED 'VENDOR'



State of West Virginia
 Department of Administration
 Purchasing Division
 2019 Washington Street East
 Post Office Box 50130
 Charleston, WV 25305-0130

Request for Quotation

RFQ NUMBER
 09110224

PAGE
 6

ADDRESS CORRESPONDENCE TO ATTENTION OF
 BUYER 33
 304-558-2402

VENDOR

RFQ COPY
 TYPE NAME/ADDRESS HERE

SHIP TO

DIVISION OF HIGHWAYS
 DISTRICT NINE
 103 1/2 CHURCH STREET
 LEWISBURG, WV
 24901 304-647-7457

| DATE PRINTED | TERMS OF SALE | SHIP VIA | F.O.B. | FREIGHT TERMS |
|--------------|---------------|----------|--------|---------------|
| 11/19/2010 | | | | |

BID OPENING DATE: 12/09/2010 BID OPENING TIME 01:30PM

| LINE | QUANTITY | UOP | CAT. NO. | ITEM NUMBER | UNIT PRICE | AMOUNT |
|--|----------|-----|----------|-------------|------------|-----------|
| EXHIBIT 10 | | | | | | |
| ADDENDUM ACKNOWLEDGEMENT | | | | | | |
| I HEREBY ACKNOWLEDGE RECEIPT OF THE FOLLOWING CHECKED ADDENDUM(S) AND HAVE MADE THE NECESSARY REVISIONS TO MY PROPOSAL, PLANS AND/OR SPECIFICATION, ETC. | | | | | | |
| ADDENDUM NOS.: | | | | | | |
| NO. 1 | | | | | | |
| NO. 2 | | | | | | |
| NO. 3 | | | | | | |
| NO. 4 | | | | | | |
| NO. 5 | | | | | | |
| I UNDERSTAND THAT FAILURE TO CONFIRM THE RECEIPT OF THE ADDENDUM(S) MAY BE CAUSE FOR REJECTION OF THE BIDS. | | | | | | |
| VENDOR MUST CLEARLY UNDERSTAND THAT ANY VERBAL REPRESENTATION MADE OR ASSUMED TO BE MADE DURING ANY ORAL DISCUSSION HELD BETWEEN VENDOR'S REPRESENTATIVES AND ANY STATE PERSONNEL IS NOT BINDING. ONLY THE INFORMATION ISSUED IN WRITING AND ADDED TO THE SPECIFICATIONS BY AN OFFICIAL ADDENDUM IS BINDING. | | | | | | |
| | | | | | | SIGNATURE |
| | | | | | | COMPANY |

| | | | |
|---|-----------|-----------------------------------|--|
| SEE REVERSE SIDE FOR TERMS AND CONDITIONS | | | |
| SIGNATURE | TELEPHONE | DATE | |
| TITLE | FEIN | ADDRESS CHANGES TO BE NOTED ABOVE | |

WHEN RESPONDING TO RFQ, INSERT NAME AND ADDRESS IN SPACE ABOVE LABELED 'VENDOR'



State of West Virginia
 Department of Administration
 Purchasing Division
 2019 Washington Street East
 Post Office Box 50130
 Charleston, WV 25305-0130

Request for Quotation

RFQ NUMBER
 09110224

PAGE
 7

ADDRESS CORRESPONDENCE TO ATTENTION OF
 BUYER 33
 304-558-2402

RFQ COPY
 TYPE NAME/ADDRESS HERE
 VENDOR

DIVISION OF HIGHWAYS
 DISTRICT NINE
 103 1/2 CHURCH STREET
 LEWISBURG, WV
 24901 304-647-7457

| DATE PRINTED | TERMS OF SALE | SHIP VIA | F.O.B. | FREIGHT TERMS |
|--------------|---------------|----------|--------|---------------|
| 11/19/2010 | | | | |

BID OPENING DATE: 12/09/2010 BID OPENING TIME 01:30PM

| LINE | QUANTITY | UOP | CAT NO | ITEM NUMBER | UNIT PRICE | AMOUNT |
|---|----------|-----|--------|-------------|------------|--------|
| <p>..... DATE</p> <p>REV. 11/96</p> <p>CONTRACTORS LICENSE</p> <p>WEST VIRGINIA STATE CODE 21-11-2 REQUIRES THAT ALL PERSONS DESIRING TO PERFORM CONTRACTING WORK IN THIS STATE MUST BE LICENSED. THE WEST VIRGINIA CONTRACTORS LICENSING BOARD IS EMPOWERED TO ISSUE THE CONTRACTORS LICENSE. APPLICATIONS FOR A CONTRACTORS LICENSE MAY BE MADE BY CONTACTING THE WEST VIRGINIA DIVISION OF LABOR CAPITOL COMPLEX, BUILDING 3, ROOM 319, CHARLESTON, WV 25305. TELEPHONE: (304) 558-7890.</p> <p>WEST VIRGINIA STATE CODE 21-11-11 REQUIRES ANY PROSPECTIVE BIDDER TO INCLUDE THE CONTRACTORS LICENSE NUMBER ON THEIR BID.</p> <p>BIDDER TO COMPLETE:</p> <p>CONTRACTORS NAME:</p> <p>CONTRACTORS LICENSE NO.:</p> <p>THE SUCCESSFUL BIDDER WILL BE REQUIRED TO FURNISH A COPY OF THEIR CONTRACTORS LICENSE PRIOR TO ISSUANCE OF A PURCHASE ORDER/CONTRACT</p> <p>APPLICABLE LAW</p> <p>THE WEST VIRGINIA STATE CODE, PURCHASING DIVISION RULES AND REGULATIONS, AND THE INFORMATION PROVIDED IN THE "REQUEST FOR QUOTATION" ISSUED BY THE PURCHASING</p> | | | | | | |

SEE REVERSE SIDE FOR TERMS AND CONDITIONS

| | | |
|-----------|-----------|-----------------------------------|
| SIGNATURE | TELEPHONE | DATE |
| TITLE | FEIN | ADDRESS CHANGES TO BE NOTED ABOVE |

WHEN RESPONDING TO RFQ, INSERT NAME AND ADDRESS IN SPACE ABOVE LABELED 'VENDOR'



State of West Virginia
 Department of Administration
 Purchasing Division
 2019 Washington Street East
 Post Office Box 50130
 Charleston, WV 25305-0130

Request for Quotation

RFQ NUMBER
 09110224

PAGE
 8

ADDRESS CORRESPONDENCE TO ATTENTION OF
 BUYER 33
 304-558-2402

VENDOR

RFQ COPY
 TYPE NAME/ADDRESS HERE

SHIP TO

DIVISION OF HIGHWAYS
 DISTRICT NINE
 103 1/2 CHURCH STREET
 LEWISBURG, WV
 24901 304-647-7457

| DATE PRINTED | TERMS OF SALE | SHIP VIA | F.O.B. | FREIGHT TERMS |
|------------------------------|---------------|--------------------------|--------|---------------|
| 11/19/2010 | | | | |
| BID OPENING DATE: 12/09/2010 | | BID OPENING TIME 01:30PM | | |

| LINE | QUANTITY | UOP | CAT NO | ITEM NUMBER | UNIT PRICE | AMOUNT |
|--|----------|-----|--------|-------------|------------|--------|
| <p>DIVISION IS THE SOLE AUTHORITY GOVERNING THIS PROCUREMENT.</p> <p>ANY INFORMATION PROVIDED IN SPECIFICATION MANUALS, OR ANY OTHER SOURCE, VERBAL OR WRITTEN, WHICH CONTRADICTS OR ALTERS THE INFORMATION PROVIDED FROM THE SOURCES AS DESCRIBED IN THE ABOVE PARAGRAPH IS VOID AND OF NO EFFECT.</p> <p>BANKRUPTCY: IN THE EVENT THE VENDOR/CONTRACTOR FILES FOR BANKRUPTCY PROTECTION, THE STATE MAY DEEM THE CONTRACT NULL AND VOID, AND TERMINATE SUCH CONTRACT WITHOUT FURTHER ORDER.</p> <p>REV. 5/2009</p> <p style="text-align: center;">NOTICE</p> <p>A SIGNED BID MUST BE SUBMITTED TO:</p> <p style="text-align: center;">DEPARTMENT OF ADMINISTRATION PURCHASING DIVISION BUILDING 15 2019 WASHINGTON STREET, EAST CHARLESTON, WV 25305-0130</p> <p>THE BID SHOULD CONTAIN THIS INFORMATION ON THE FACE OF THE ENVELOPE OR THE BID MAY NOT BE CONSIDERED:</p> <p>SEALED BID</p> <p>BUYER: 33</p> <p>REQ. NO.: 09110224</p> | | | | | | |

| | | |
|---|-----------|-----------------------------------|
| SEE REVERSE SIDE FOR TERMS AND CONDITIONS | | |
| SIGNATURE | TELEPHONE | DATE |
| TITLE | FEIN | ADDRESS CHANGES TO BE NOTED ABOVE |

WHEN RESPONDING TO RFQ, INSERT NAME AND ADDRESS IN SPACE ABOVE LABELED 'VENDOR'



State of West Virginia
 Department of Administration
 Purchasing Division
 2019 Washington Street East
 Post Office Box 50130
 Charleston, WV 25305-0130

Request for Quotation

RFQ NUMBER
 09110224

PAGE
 9

ADDRESS CORRESPONDENCE TO ATTENTION OF
 BUYER 33
 304-558-2402

VENDOR

RFQ COPY
 TYPE NAME/ADDRESS HERE

SHIP TO

DIVISION OF HIGHWAYS
 DISTRICT NINE
 103 1/2 CHURCH STREET
 LEWISBURG, WV
 24901 304-647-7457

| DATE PRINTED | TERMS OF SALE | SHIP VIA | F.O.B. | FREIGHT TERMS |
|--------------|---------------|----------|--------|---------------|
| 11/19/2010 | | | | |

BID OPENING DATE: 12/09/2010 BID OPENING TIME 01:30PM

| LINE | QUANTITY | UOP | CAT NO | ITEM NUMBER | UNIT PRICE | AMOUNT |
|--|----------|-----|--------|-------------|------------|--------|
| BID OPENING DATE: | | | | 12/09/2010 | | |
| BID OPENING TIME: | | | | 1:30 PM | | |
| PLEASE PROVIDE A FAX NUMBER IN CASE IT IS NECESSARY TO CONTACT YOU REGARDING YOUR BID: | | | | | | |
| ----- | | | | | | |
| PLEASE PRINT OR TYPE NAME OF PERSON TO CONTACT CONCERNING THIS QUOTE: | | | | | | |
| ----- | | | | | | |
| ***** THIS IS THE END OF RFQ 09110224 ***** TOTAL: | | | | | | |

SEE REVERSE SIDE FOR TERMS AND CONDITIONS

| | | |
|-----------|-----------|------|
| SIGNATURE | TELEPHONE | DATE |
|-----------|-----------|------|

| | | |
|-------|------|-----------------------------------|
| TITLE | FEIN | ADDRESS CHANGES TO BE NOTED ABOVE |
|-------|------|-----------------------------------|

WHEN RESPONDING TO RFQ, INSERT NAME AND ADDRESS IN SPACE ABOVE LABELED 'VENDOR'

SECTION 02831

CHAIN-LINK FENCES AND GATES

PART 1 – GENERAL

1.01 WORK INCLUDED

- A. Fence framework, fabric and accessories.
- B. Gates and related hardware.
- C. Installation

1.02 SCOPE OF WORK

- A. *Summary:* This section covers the work necessary to complete the chain link fence and gate installation.
- B. *General:* Like items of materials provided hereafter shall be the end products of one manufacturer in order to achieve standardization for appearance, maintenance and replacement. Major components including but not limited to Fence Framework and Chain-link Fabric shall be manufactured in the U.S.A.
- C. *Delivery, Storage and Handling:* Deliver material to the site in an undamaged condition. Carefully store material off the ground to provide proper protection against oxidation caused by ground moisture.

1.03 SUBMITTALS AND MILL CERTIFICATION

- A. *Shop Drawings:* Include complete details of fence and gate construction, fence height, post spacing, dimensions and unit weights of framework and concrete footing details.
- B. *Product Data:* Provide manufacturer's catalog cuts with printed specifications. Manufacturer shall provide certification of compliance with material specifications. Actual samples of the material may be requested.

PART 2 – PRODUCTS

2.01 MATERIALS

- A. *Acceptable Manufacturers OR EQUAL*
 - 1. Allied Tube & Conduit
16100 South Lathrop Avenue
Harvey, Illinois 60426
708-339-1610

- B. **Framework:** Steel pipe conforming to Standard Specification ASTM F1043 Group IA (Schedule 40); external coatings per F1043 Type A; internal coatings Type A, or high strength steel pipe triple coated per Standard Specification ASTM F1043 Group IC (SS40 as manufactured by Allied Tube & Conduit or approved equal); external coatings per F1043 Type B; internal coatings per F1043 Type D.

All coatings to be applied after welding.

Pipe shall be straight, true to section and conform to the following weights:

| <u>Pipe Size</u> <u>Outside Diameter</u> | <u>Group IA</u> <u>Weight Lbs./Ft.</u> | <u>Group IC</u> <u>Weight Lbs./Ft.</u> |
|---|---|---|
| 1-5/8" | 2.27 | 1.84 |
| 1-7/8" | 2.72 | 2.28 |
| 2-3/8" | 3.65 | 3.12 |
| 2-7/8" | 5.79 | 4.64 |
| 3-1/2" | 7.58 | 5.71 |
| 4" | 9.11 | 6.56 |
| 6-5/8" | 18.97 | -- |
| 8-5/8" | 24.70 | -- |

- C. **Fabric:** Aluminized fabric shall be manufactured in accordance with ASTM A491 and coated before weaving with a minimum of 0.4 ounces of aluminum per square foot of surface area. The steel wire and coating shall conform to ASTM A817. Fabric to be 9 gauge woven in a 2" diamond mesh. Top selvage to be twisted and barbed. Bottom selvage to be knuckled unless otherwise specified.

Zinc-coated fabric shall be galvanized after weaving with a minimum 1.2 ounces of zinc per square foot of surface area and conform to ASTM A392, Class 1. Fabric to be 9 gauge wire woven in a 2" diamond mesh. Top selvage to be twisted and barbed, bottom selvage to be knuckled unless otherwise specified.

2.02 CONCRETE MIX

- A. Concrete conforming to ASTM C 94, having a minimum compressive strength of 3,000 PSI at 28 days.

2.03 COMPONENTS

A. *Fence Posts:*

| <u>Fabric Height</u> | <u>Group IA or IC</u> | |
|----------------------|-----------------------|---------------------------|
| | <u>Line Post O.D.</u> | <u>Terminal Post O.D.</u> |
| Under 6' | 1-7/8" | 2-3/8" |
| 6' to 9' | 2-3/8" | 2-7/8" |
| 9' to 12' | 2-7/8" | 4" |

B. *Swing Gate Posts:*

| <u>Single Gate Width</u> | <u>Double Gate Width</u> | <u>Post O.D. Group IA or IC</u> |
|--------------------------|--------------------------|---------------------------------|
| Up to 6' | Up to 12' | 2-7/8" |
| 7' to 12' | 13' to 24' | 4" |
| 13' to 18' | 25' to 36' | 6-5/8" Group IA |
| Over 18' | Over 36' | 8-5/8" Group IA |

C. *Rails and Braces:* 1-5/8" O.D. Group IA or IC.

D. *Gates:* Frame assembly of 1-7/8" O.D. pipe Group IA or IC with welded joints. Weld areas repaired with zinc-rich coating applied per manufacturer's directions. Fabric to match fence. Gate accessories, hinges, latches, center stops, keepers and necessary hardware of quality required for industrial and commercial application. Latches shall permit padlocking.

E. *Fittings:*

Post Caps – Pressed steel, cast iron or cast aluminum alloy designed to fit snugly over posts to exclude moisture. Supply dome style caps for terminal posts and loop type for line posts. All fittings to conform to ASTM F626.

Rail and Brace Ends – Pressed steel, cast iron or cast aluminum alloy, cup-shaped to receive rail and brace ends.

Top Rail Sleeves – Tubular steel, 0.051 thickness x 7" long, expansion type.

Tension Bars – Steel strip, 5/8" wide x 3/16" thick.

Tension Bands – Pressed steel, 14 gauge thickness x 3/4" wide.

Brace Bands – Pressed steel, 12 gauge thickness x 3/4" wide.

Truss Rods – Steel rod, 3/8" diameter merchant quality with turnbuckle (take up).

Barbed Wire Arms – Pressed steel, cast iron or cast aluminum alloy fitted with clips or slots for attaching three strands of barbed wire. Arms shall be set outward on a 45 degree angle and be capable of supporting a 250 pound load at outer barbed wire connecting point without causing permanent deflection.

- F. **Tension Wire:** Marcellled 7 gauge steel wire with minimum coating of 0.80 ounces of zinc or 0.40 ounces of aluminum per square foot of wire surface and conforming to ASTM A824.
- G. **Tie Wires:** Aluminum, 9 gauge, alloy 1100-H4 or equal.
- H. **Hog Rings:** Steel wire, 11 gauge, with a minimum zinc coating of 0.80 ounces per square foot of wire surface.
- I. **Barbed Wire:** If required, commercial quality steel, 12-1/2 gauge, two strand twisted line wire with 4 point barbs at 5 inch spacing. Coating shall consist of a minimum of 0.80 ounces of zinc per square foot of wire surface conforming to ASTM A121 or a minimum of 0.30 ounces of aluminum per square foot of wire surface conforming to ASTM A585.
- J. **Barbed Tape:** If required, options are available in ASTM F1910 Table 1 and 2.

PART 3 – EXECUTION

3.01 INSTALLATION

- A. **General:** Installation to conform to ASTM F567.
- B. **Height:** Provide height as indicated on contract drawings.
- C. **Post Spacing:** Space line posts at intervals not exceeding ten feet.
- D. **Post Setting:** Set terminal, gate and line posts plumb in concrete footings. Top of footing to be 2" above grade and sloped to direct water away from posts.
- E. **Bracing:** Brace Gate and terminal posts back to adjacent line posts with horizontal brace rails and diagonal truss rods.
- F. **Top Rail:** Install through line loop caps connecting sections with sleeves to form a continuous rail between terminal posts.
- G. **Top Tension Wire:** When top rail is omitted, stretch tension wire through loop caps and fasten to terminal posts.

- H. ***Bottom Tension Wire:*** Stretch between terminal posts 6" above grade and fasten to outside of line posts with tie wires.
- I. ***Fabric:*** Pull fabric taut with bottom selvage 2" above grade. Fasten to terminal posts with tension bars threaded through mesh and secured with tension bands at maximum 15" intervals. Tie to line posts and top rails with tie wires spaced at maximum 12" on posts and 24" on rails. Attach to bottom tension wire with top rings at maximum 24" intervals.
- J. ***Barbed Wire:*** Anchor to terminal extension arms, pull taut and firmly install in slots of line post extension arms.
- K. ***Gates:*** Install gates plumb, level and secure for full opening without interference. Anchor center stops and keepers in concrete.
- L. ***Fasteners:*** Install nuts for fittings, bands and hardware bolts on inside of fence.

3.02 COMPLETION

- A. The area of installation shall be left free of debris caused by the installation of the fence

End of Section

APPROXIMATELY 1417 LF
7' HIGH - CHAINLINK
WITH BARBED WIRE FENCE

1 SET DOUBLE DRIVE GATE
24 Foot

MONROE COUNTY, WV

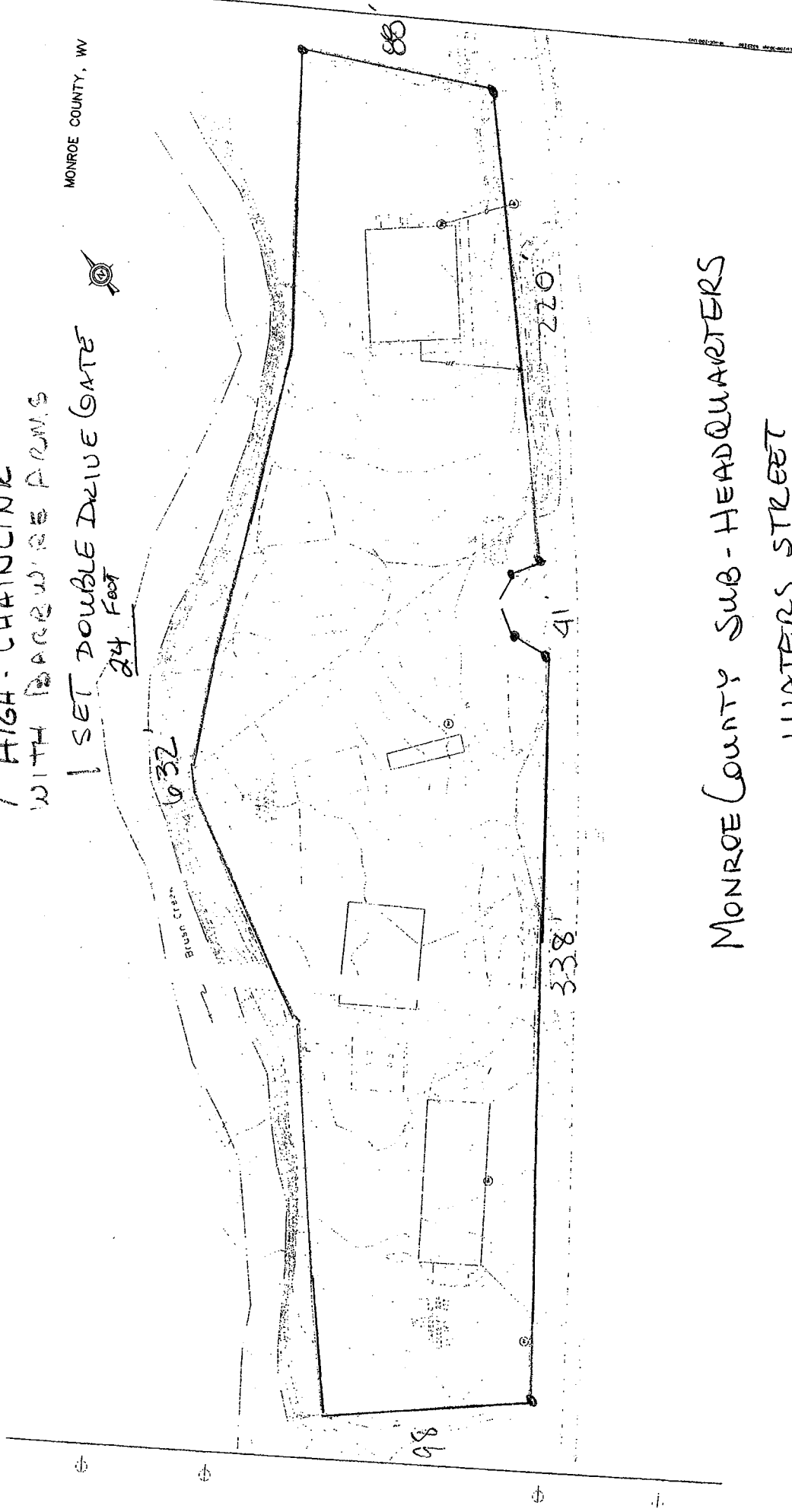

MONROE COUNTY SUB-HEADQUARTERS

WATERS STREET

PETERSTOWN WV
24963

LOCATED WV 12 0.1 NORTH OF CITY LIMITS

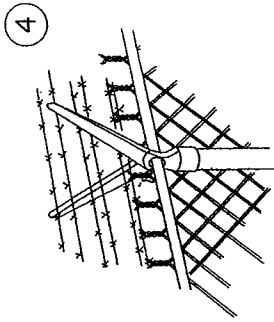

9 GA. ALUMINUM FABRIC TIES
5 PER SECTION OF RAIL & BRACE
LINE POST TO HAVE 1 LESS THAN
FABRIC HEIGHT

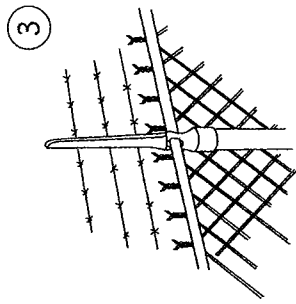

- STYLES OF FENCE
DESCRIPTION (ALL W/TOP RAIL.)
- ① NO BARB WIRE WITH TOP RAIL
 - ② THREE STRANDS BARB WIRE AT 45° ANGLE
 - ③ THREE STRANDS BARB WIRE VERTICAL
 - ④ SIX STRANDS BARB WIRE WITH TOP RAIL

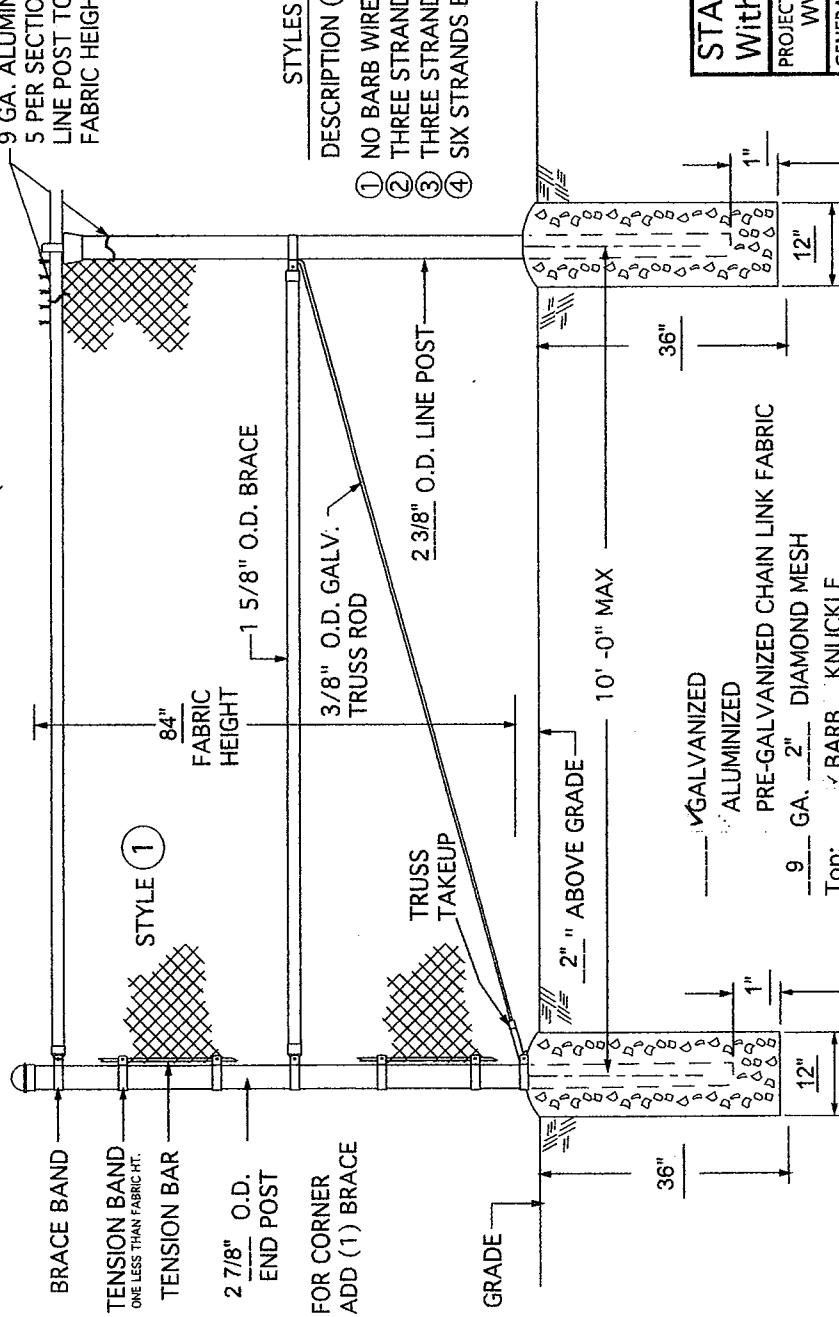
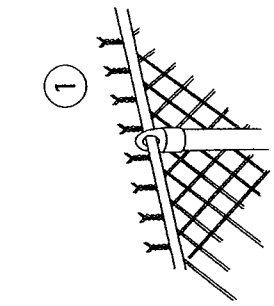
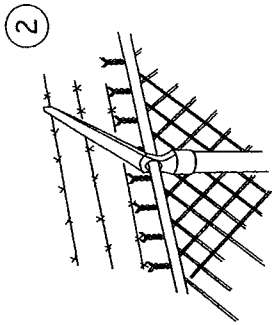

N.T.S.

| | |
|------------------------------|----------------------------|
| STANDARD FENCE DETAIL | |
| With Top Rail | |
| PROJECT | WVDOH - Peterstown, WV Lot |
| GENERAL CONTRACTOR | |
| FENCE CONTRACTOR | |
| DATE | 10-21-10 |
| SUBMITTED BY | Martin Smith |
| | 1 / 3 |

9 GA. 2" DIAMOND MESH
Top: BARB KNUCKLE
Bottom: BARB KNUCKLE

GALVANIZED
 ALUMINIZED
 PRE-GALVANIZED CHAIN LINK FABRIC



CORNER BARB ARM

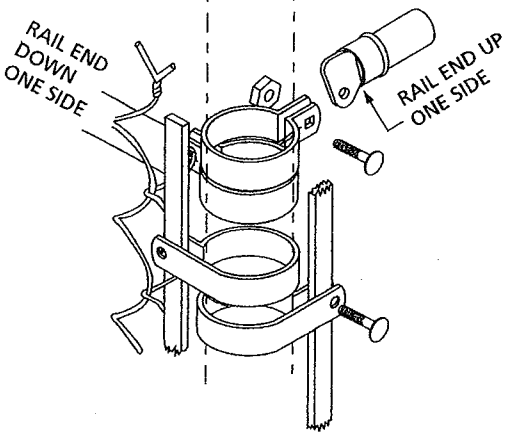

CORNER POST DETAIL

ONE PIECE
PRESSED STEEL
45° BARB ARM
OR VERTICAL ARM
OR "Y" ARM

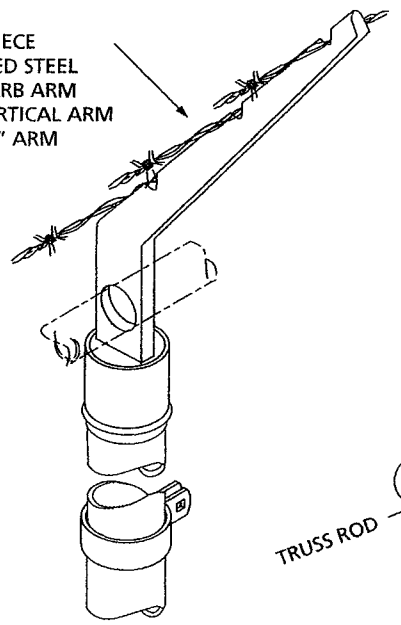

END POST DETAIL

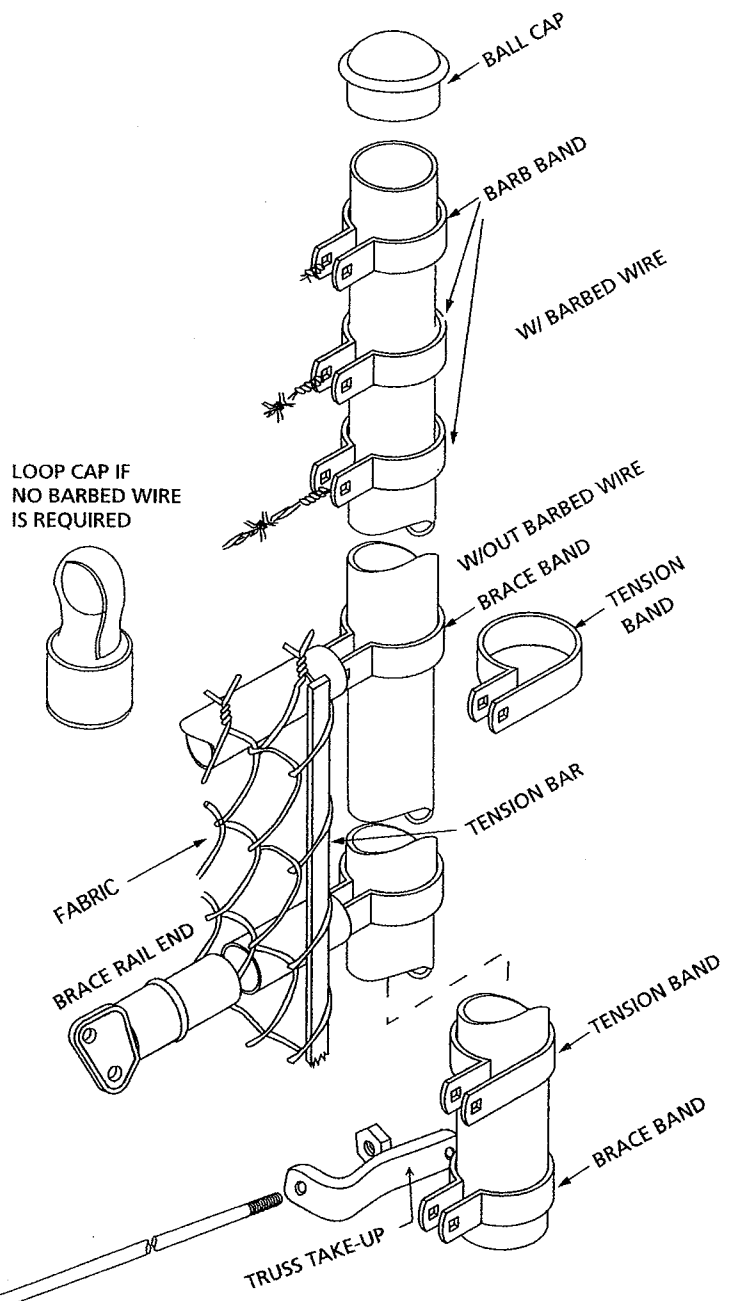

LOOP CAP IF
NO BARBED WIRE
IS REQUIRED

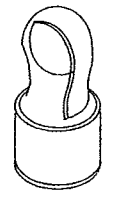

| | |
|---------------------------------------|------------------|
| N.T.S. | |
| STANDARD FITTINGS DETAIL | |
| PROJECT WVDOH - Peterstown, WV Lot | |
| GENERAL CONTRACTOR | |
| FENCE CONTRACTOR | DATE 10-21-10 |
| SUBMITTED BY Martin Smith | 2/3 |

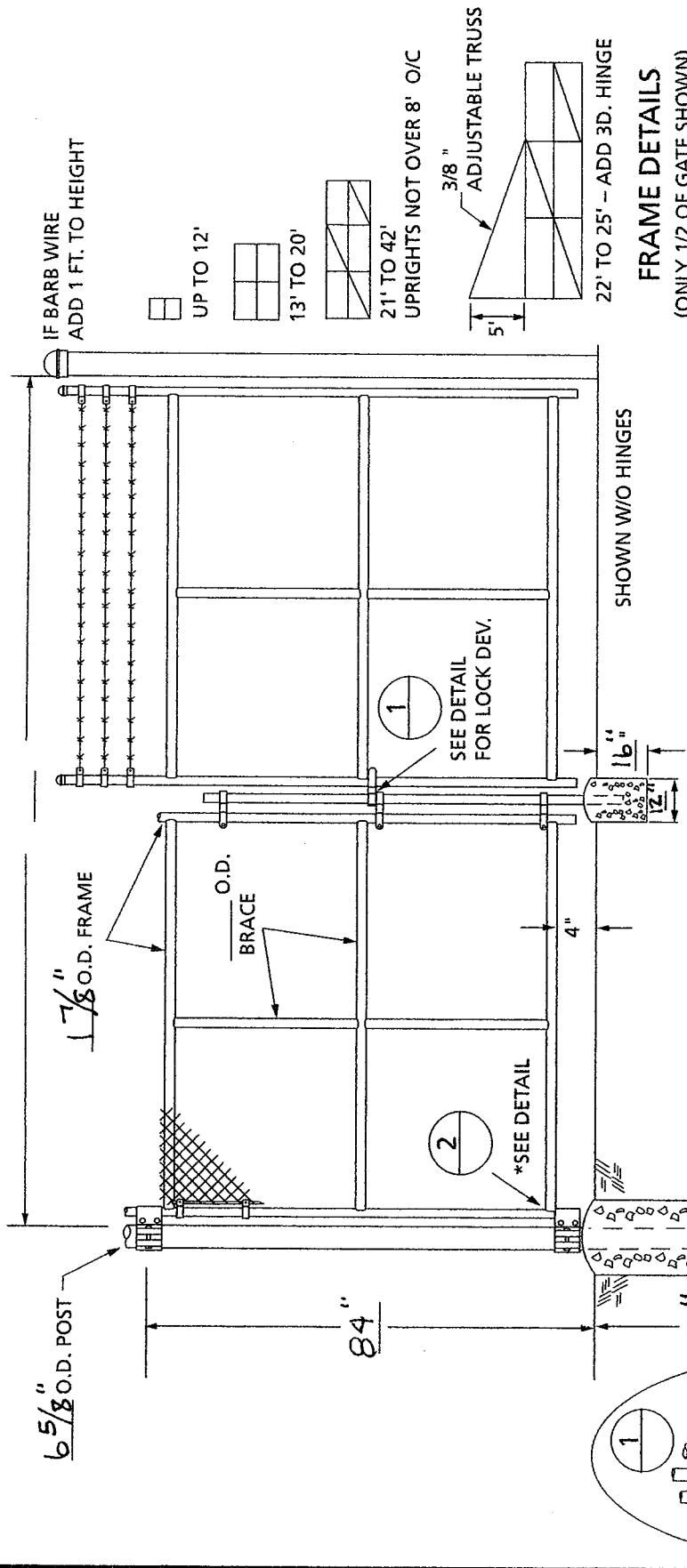

*ALL WELDED CONST.

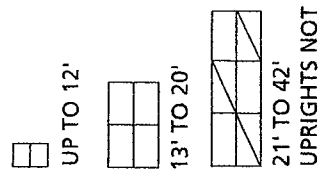
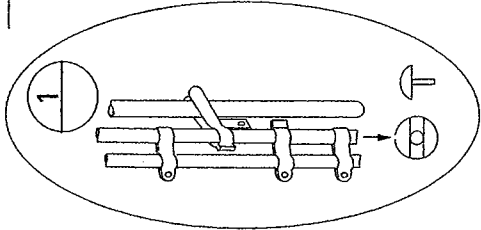
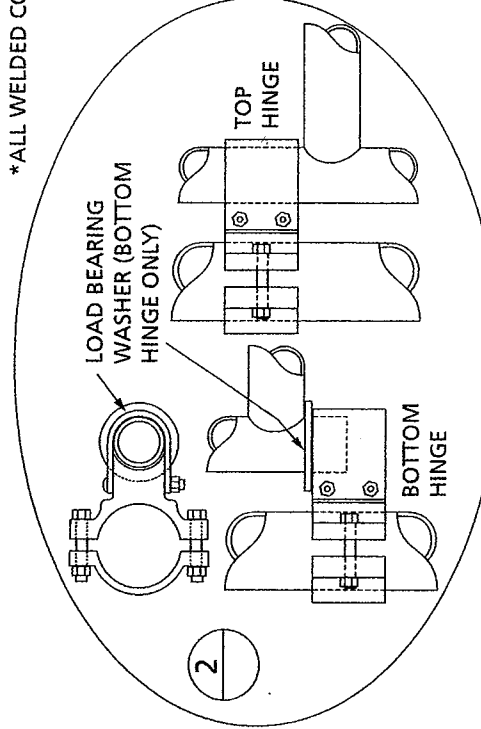

FRAME DETAILS
(ONLY 1/2 OF GATE SHOWN)

| | |
|---------------------------------------|------------------|
| STANDARD DOUBLE DRIVE GATE | N.T.S. |
| PROJECT WUDOH - PETERSTOWN, WV LOT | DATE 10-24-16 |
| GENERAL CONTRACTOR | |
| FENCE CONTRACTOR | |
| SUBMITTED BY MARTIN SMITH | 3/3 |





State of West Virginia
DRUG FREE WORKPLACE CONFORMANCE AFFIDAVIT
West Virginia Code §21-1D-5

STATE OF _____

COUNTY OF _____, TO-WIT:

I, _____, after being first duly sworn, depose and state as follows:

1. I am an employee of _____; and,
(Company Name)

2. I do hereby attest that _____
(Company Name)

maintains a valid written drug free workplace policy and that such policy is in compliance with **West Virginia Code §21-1D-5**.

The above statements are sworn to under the penalty of perjury.

(Company Name)

By: _____

Title: _____

Date: _____

Taken, subscribed and sworn to before me this _____ day of _____.

By Commission expires _____

(Seal)

(Notary Public)

THIS AFFIDAVIT MUST BE SUBMITTED WITH THE BID IN ORDER TO COMPLY WITH WV CODE PROVISIONS. FAILURE TO INCLUDE THE AFFIDAVIT WITH THE BID SHALL RESULT IN DISQUALIFICATION OF THE BID.

RFQ No. _____

STATE OF WEST VIRGINIA
Purchasing Division

PURCHASING AFFIDAVIT

West Virginia Code §5A-3-10a states: No contract or renewal of any contract may be awarded by the state or any of its political subdivisions to any vendor or prospective vendor when the vendor or prospective vendor or a related party to the vendor or prospective vendor is a debtor and the debt owned is an amount greater than one thousand dollars in the aggregate

DEFINITIONS:

"Debt" means any assessment, premium, penalty, fine, tax or other amount of money owed to the state or any of its political subdivisions because of a judgment, fine, permit violation, license assessment, defaulted workers' compensation premium, penalty or other assessment presently delinquent or due and required to be paid to the state or any of its political subdivisions, including any interest or additional penalties accrued thereon.

"Debtor" means any individual, corporation, partnership, association, Limited Liability Company or any other form or business association owing a debt to the state or any of its political subdivisions. "Political subdivision" means any county commission; municipality; county board of education; any instrumentality established by a county or municipality; any separate corporation or instrumentality established by one or more counties or municipalities, as permitted by law; or any public body charged by law with the performance of a government function or whose jurisdiction is coextensive with one or more counties or municipalities. "Related party" means a party, whether an individual, corporation, partnership, association, limited liability company or any other form or business association or other entity whatsoever, related to any vendor by blood, marriage, ownership or contract through which the party has a relationship of ownership or other interest with the vendor so that the party will actually or by effect receive or control a portion of the benefit, profit or other consideration from performance of a vendor contract with the party receiving an amount that meets or exceed five percent of the total contract amount.

EXCEPTION: The prohibition of this section does not apply where a vendor has contested any tax administered pursuant to chapter eleven of this code, workers' compensation premium, permit fee or environmental fee or assessment and the matter has not become final or where the vendor has entered into a payment plan or agreement and the vendor is not in default of any of the provisions of such plan or agreement.

Under penalty of law for false swearing (*West Virginia Code* §61-5-3), it is hereby certified that the vendor affirms and acknowledges the information in this affidavit and is in compliance with the requirements as stated.

WITNESS THE FOLLOWING SIGNATURE

Vendor's Name: _____

Authorized Signature: _____ Date: _____

State of _____

County of _____, to-wit:

Taken, subscribed, and sworn to before me this ____ day of December, 20__.

My Commission expires _____, 20__.

AFFIX SEAL HERE

NOTARY PUBLIC _____