

PUBLIC ROADS DIV.	STATE DIST. NO.	PROJECT NUMBER	COUNTY	SHEET NO.	TOTAL SHEETS
WV	8	S336-18-3.77	PENDLETON	0	00

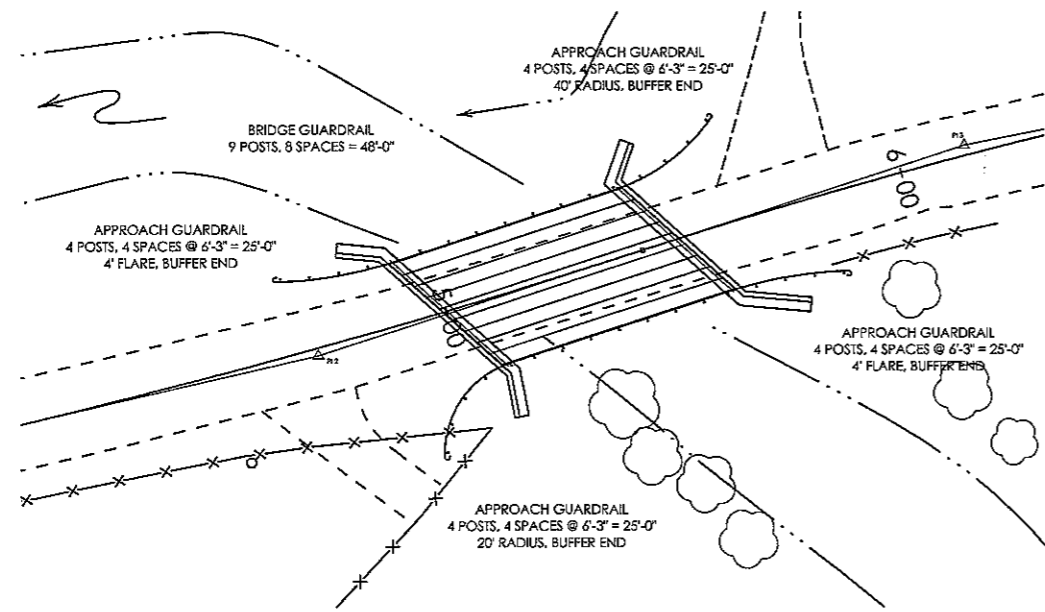

GUARDRAIL LAYOUT

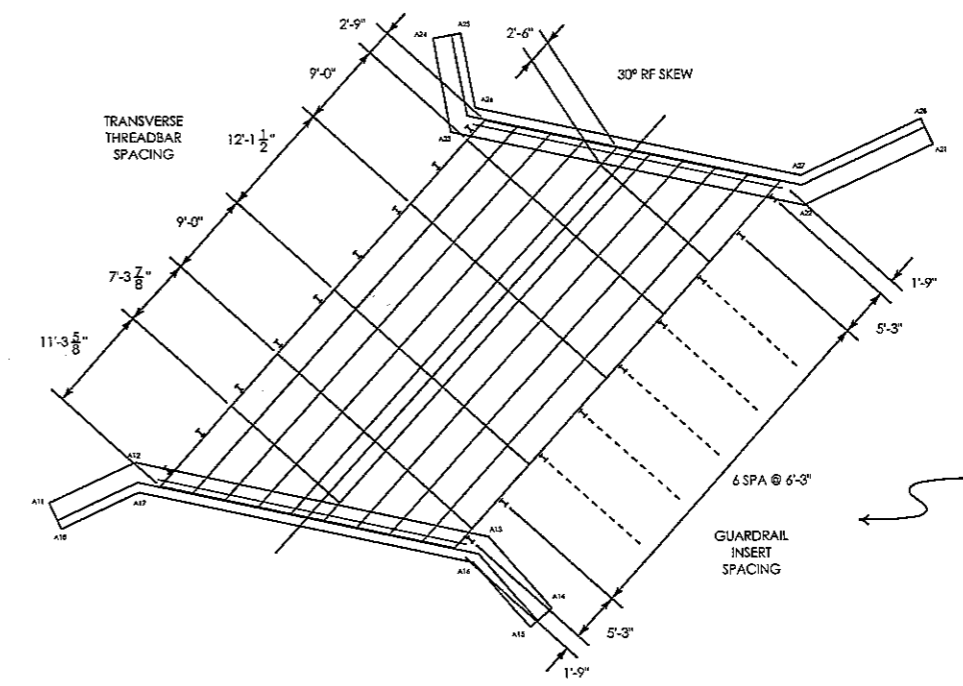

SUPERSTRUCTURE LAYOUT

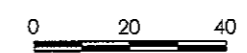

NO.	REVISION	DATE	BY

THE WEST VIRGINIA DIVISION OF HIGHWAYS
STRUCTURES DIVISION

**SECOND SMITH CREEK BRIDGE
OVER SMITH CREEK
IN PENDLETON COUNTY**

DESIGNED BY: PRB	DATE: 4/09
DRAWN BY: PRB	DATE: 4/09
CHECKED BY:	
REVISION BY:	

GUARDRAIL PLAN
SUPERSTRUCTURE PLAN

SHEET 0 OF 00
BRIDGE NUMBER
10935

PROJECT NUMBERS		DISTRICT	COUNTY	SHEET NO.	TOTAL
STATE	FEDERAL				
S336-18-3.77		8	PENDLETON	00	00

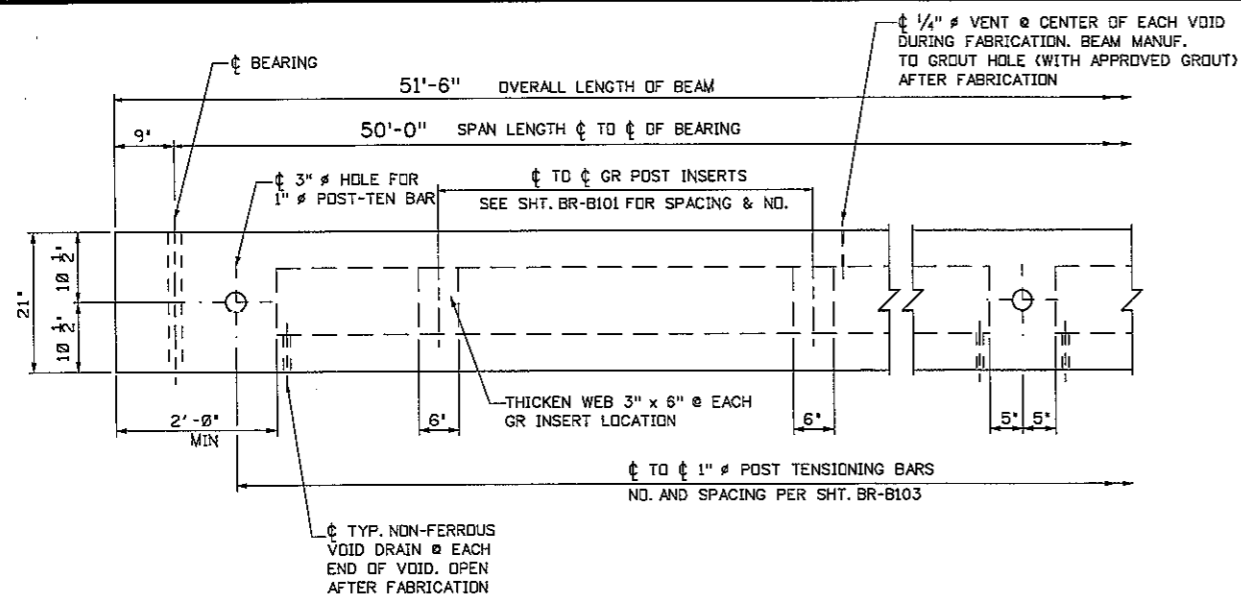

GENERAL ELEVATION VIEW

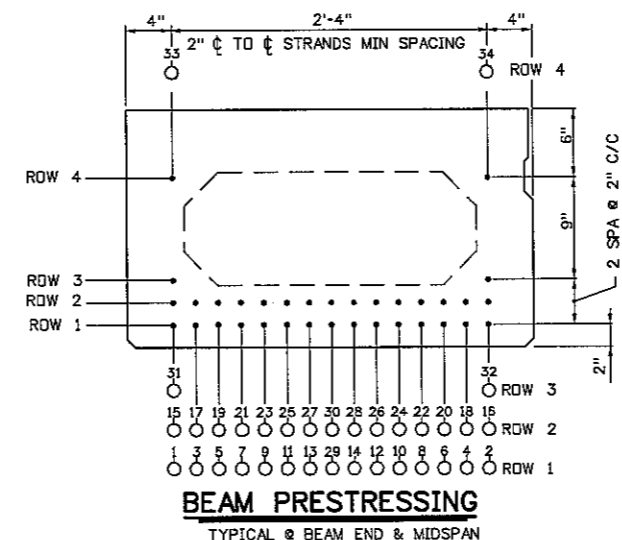

BEAM PRESTRESSING
TYPICAL @ BEAM END & MIDSPAN

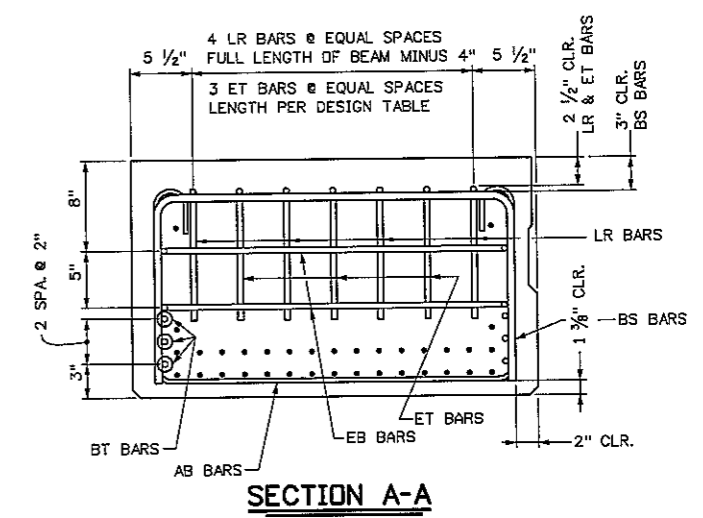

SECTION A-A

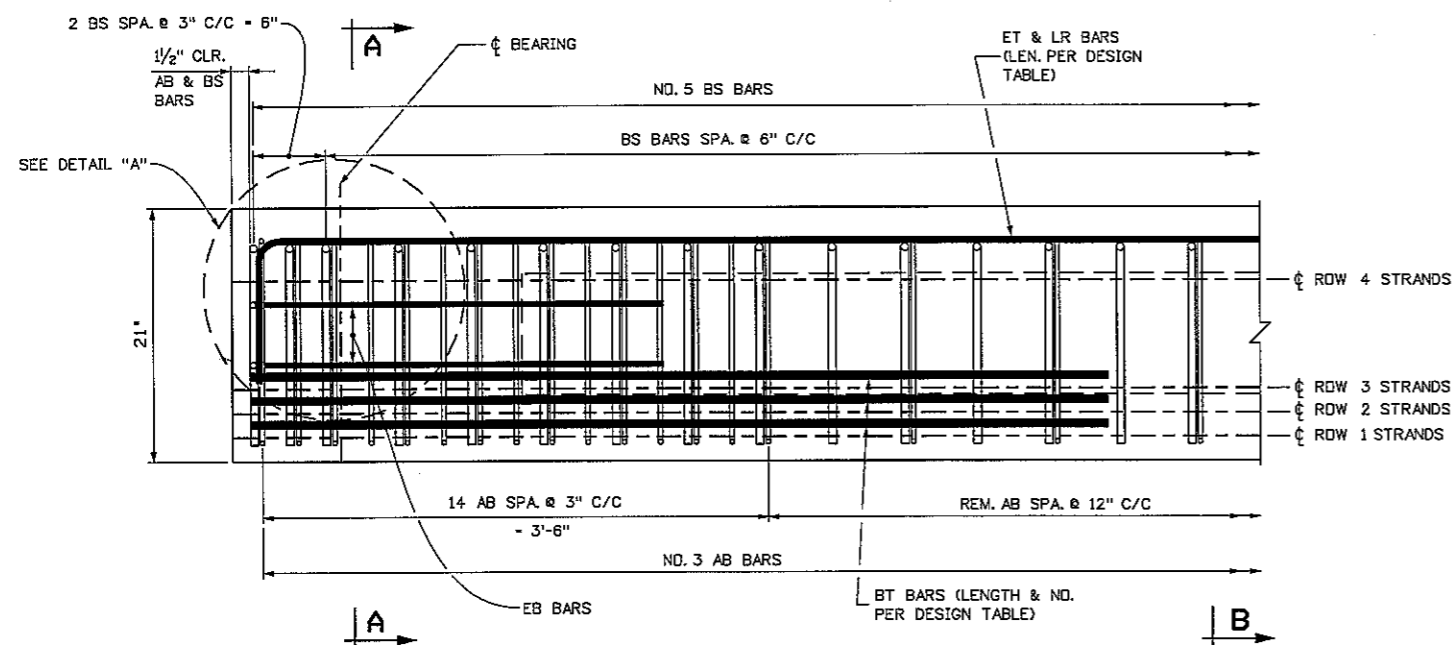

REINFORCING STEEL ELEVATION

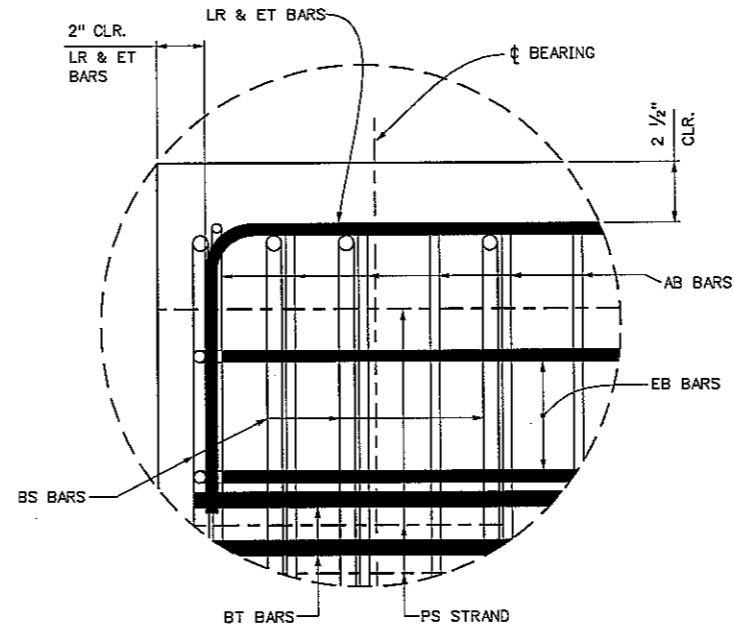

DETAIL "A"

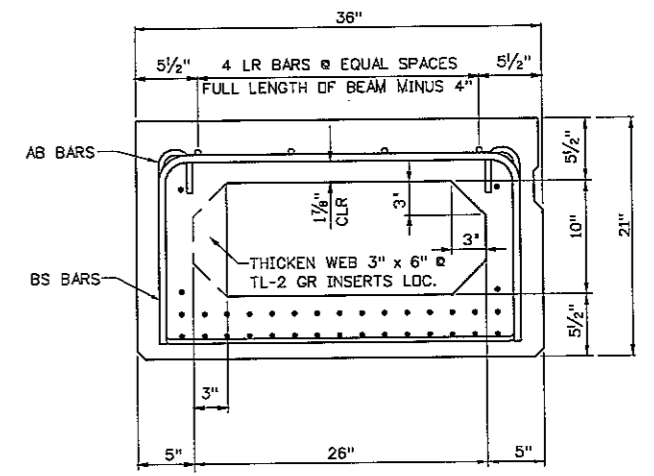

SECTION B-B

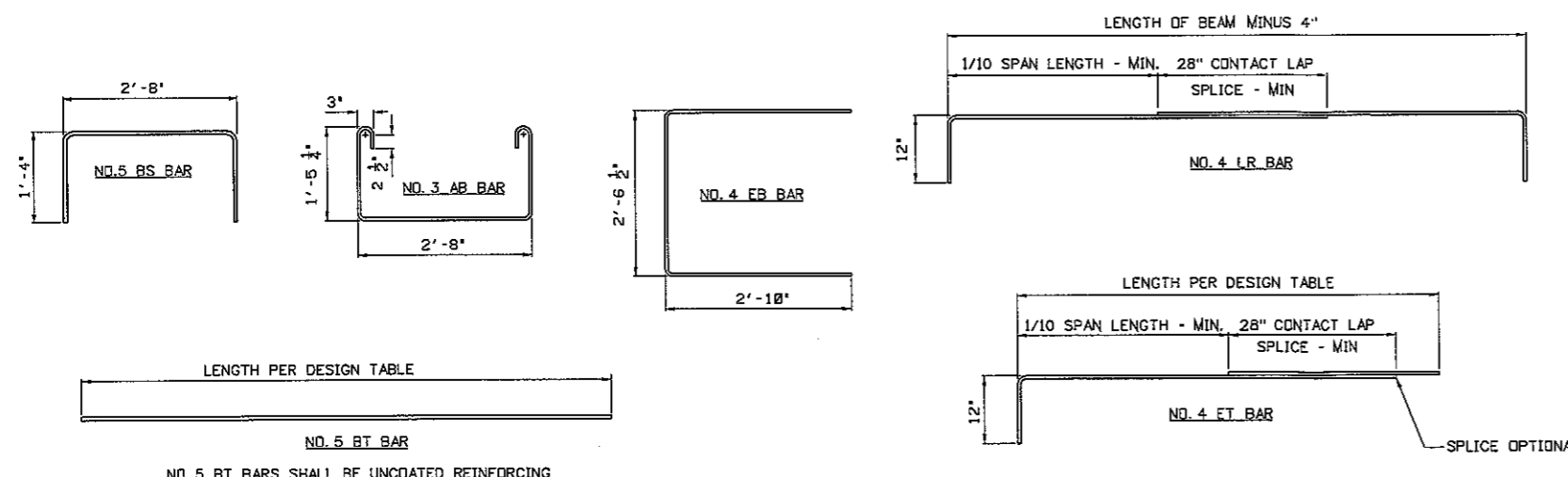

REINFORCING BAR DETAIL

NOTES:

- REFER TO SHEET BR-B102A FOR SHEAR KEY DETAILS.
- DESIGNER SHALL USE THE FOLLOWING KEY TO INDICATE STRAND AND DEBONDING PATTERN ON 'BEAM PRESTRESSING VIEW', THIS SHEET.
 - ACTIVE STRAND
 - ▽ DEBOND STRAND: LENGTH FROM END OF BEAM
 - △ DEBOND STRAND: LENGTH FROM END OF BEAM
 - DEBOND STRAND: LENGTH FROM END OF BEAM
- THIS SHEET SHALL BE USED IN CONJUNCTION WITH STANDARD SHEETS BR-B21B, BR-B100, BR-B101, BR-B102A & B, BR-B103, BR-B104, BR-B105A & B AND BR-B106 AS APPLICABLE.

WHEN A POST-TEN ACCESS POCKET IS USED AS DETAILED ON SHEET BR-103 STRANDS IN ROWS 3 AND 4 SHALL BE ELIMINATED. THE BEAM SHALL BE REDESIGNED AS NECESSARY.

APPROVED: *Gregory Bailey*
DIRECTOR, ENGINEERING DIVISION DATE: 10-25-07

WEST VIRGINIA DEPARTMENT OF TRANSPORTATION
DIVISION OF HIGHWAYS
ENGINEERING DIVISION

PREPARED: 07-02-07

21' PRESTRESSED CONCRETE BOX BEAMS
DESIGN AND ASSEMBLY DETAILS

STANDARD SHEET BR-B21A

WEST VIRGINIA DEPARTMENT OF TRANSPORTATION
DIVISION OF HIGHWAYS
ENGINEERING DIVISION

**SECOND SMITH CREEK BRIDGE
OVER SMITH CREEK
IN PENDLETON COUNTY**

21' PRESTRESSED CONCRETE BOX BEAM
DESIGN AND ASSEMBLY DETAILS

DESIGNED BY:TW/
DRAWN BY:BH/
CHECKED BY:TW/
REVIEWED BY:THB/
DATE:
SCALE: 4/09
SHEET 00 OF 00
BRIDGE NO. 10935

STATE PROJECT NUMBER	FEDERAL PROJECT NUMBER	STATE DIST. NO.	COUNTY	SHEET NO.	TOTAL SHEETS
5336-18-3.77		8	PENDLETON	00	00

DESIGN DATA FOR 21' DEPTH ADJACENT BOX BEAM

SPAN LENGTH ϕ TO ϕ BEARING		30'-0"	32'-0"	34'-0"	36'-0"	38'-0"	40'-0"	42'-0"	44'-0"	46'-0"	48'-0"	50'-0"
OVERALL LENGTH OF BEAM		31'-8"	33'-6"	35'-6"	37'-6"	39'-6"	41'-6"	43'-6"	45'-6"	47'-6"	49'-6"	51'-6"
NO. OF 270 KSI, 1/2" ϕ LOW-RELAXATION STRANDS, AREA/STRAND - 0.167 SQ. IN.		10	10	10	12	12	14	14	14	16	16	16
STRAND POSITION NUMBER	ROW 1	1,2,11,12	1,2,11,12	1,2,11,12	1,2,7,8,13,14	1,2,7,8,13,14	1,2,7,8,13,14	1,2,7,8,13,14	1,2,7,8,13,14	1,2,5,6,9,10,13,14	1,2,5,6,9,10,13,14	1,2,5,6,9,10,13,14
	ROW 2	15,16,25,26	15,16,25,26	15,16,25,26	15,16,27,28	15,16,27,28	15,16,21,22,27,28	15,16,21,22,27,28	15,16,21,22,27,28	15,16,21,22,27,28	15,16,21,22,27,28	15,16,21,22,27,28
	ROW 3	---	---	---	---	---	---	---	---	---	---	---
	ROW 4	33,34	33,34	33,34	33,34	33,34	33,34	33,34	33,34	33,34	33,34	33,34
PRESTRESSING FORCE IMMEDIATELY AFTER STRAND RELEASE, Ppt, (KIPS/BEAM)		327	328	328	391	391	453	454	454	515	515	517
EFFECTIVE PRESTRESSING FORCE AFTER ALL LOSSES, Ppe, (KIPS/BEAM)		297	298	298	350	352	403	404	406	454	456	458
REQUIRED FACTORED MOMENT @ STRENGTH I, Mu (FT-KIPS/BEAM)		359	393	427	465	504	545	588	639	683	746	800
FACTORED FLEXURAL RESISTANCE, Mr (FT-KIPS/BEAM)		527	527	527	644	644	743	743	743	853	853	853
TOTAL NO. DEBONDED STRANDS		---	---	---	---	---	---	---	---	---	---	---
DEBONDED STRAND POSITION NUMBER & SHIELDING LENGTH FROM EACH END	ROW 1	---	---	---	---	---	---	---	---	---	---	---
	ROW 2	---	---	---	---	---	---	---	---	---	---	---
NUMBER & LENGTH #4 ET TOP TENSION BARS @ EACH END		3 - #4 x 4'-6"	3 - #4 x 4'-6"	3 - #4 x 5'-0"	3 - #4 x 5'-0"	3 - #4 x 5'-0"	3 - #4 x 5'-6"	3 - #4 x 5'-6"	3 - #4 x 6'-0"	3 - #4 x 6'-0"	3 - #4 x 6'-0"	3 - #4 x 6'-6"
NUMBER & LENGTH #5 BT BOTTOM TENSION BARS @ EACH END		2 - #5 x 5'-0"	2 - #5 x 5'-0"	2 - #5 x 6'-0"	2 - #5 x 6'-0"	2 - #5 x 6'-0"	2 - #5 x 6'-0"	2 - #5 x 6'-0"	2 - #5 x 6'-0"	2 - #5 x 6'-0"	2 - #5 x 6'-0"	2 - #5 x 6'-0"
DESIGN CAMBER + = POSITIVE (UP) (INCHES)	@ RELEASE	0.15	0.15	0.15	0.26	0.27	0.37	0.38	0.38	0.55	0.55	0.54
	@ ERECTION	0.23	0.23	0.22	0.40	0.39	0.56	0.55	0.52	0.79	0.76	0.71
	@ FINAL	0.24	0.22	0.18	0.40	0.36	0.55	0.49	0.40	0.70	0.59	0.45
NUMBER & SPACING OF TL-2 GUARDRAIL INSERTS SEE NOTE 6	NO OF INSERTS REQD.											9
	END OF BEAM TO ϕ OF FIRST INSERT EA. END											1'-9"
	ϕ OF 1st INSERT TO ϕ 2nd INSERT EA. END											5'-3"
WEIGHT OF TYPICAL BEAM INCLUDING DIAPHRAGM (TONS)		9.2	9.8	10.4	10.9	11.5	12.0	12.6	13.1	13.8	14.3	14.9

MIN. CONCRETE STRENGTH @ RELEASE = 5500 PSI
 MIN. CONCRETE STRENGTH @ 28 DAYS = 8000 PSI
 INITIAL PULL/STRAND = 33,820 LBS
 CROSS-SECTION AREA/STRAND = 0.167 SQ. IN.

NOTES

- BEAM WEIGHTS LISTED IN THE DESIGN TABLE ARE BASED ON ZERO SKEW, 2 FT. LONG ENDBLOCK AND DIAPHRAGMS SPACED @ 15 FT C/C. WEIGHTS FOR SKEWED BEAMS, LONGER ENDBLOCKS AND ADDITIONAL DIAPHRAGMS SHOULD BE ADJUSTED ACCORDINGLY.
 FOR ADDITIONAL DIAPHRAGMS, ADD 226 LBS/DIAPHRAGM.
 FOR SKEW ADD 21 LBS/DEGREE OF SKEW/END.
 FOR LONGER ENDBLOCK, ADD 271 LBS/LF/END.
- DESIGNERS SHOULD NOTE THAT DATA IN STANDARD TABLE IS BASED ON EVEN SPAN LENGTHS, A TWO LANE STRUCTURE 8 BEAMS WIDE AND ZERO SKEW. SUPERIMPOSED DEAD LOADS INCLUDE TYPE F PARAPET (321 PLF) AND A FWS OF 50 PSF. FOR NON-STANDARD BRIDGES DATA SHOULD BE VERIFIED AND IF REQUIRED NEW DESIGN DATA ENTERED INTO BLANK COLUMNS. IN NO CASE SHALL THE STANDARD DESIGN TABLE BE ALTERED.
- PREDICTED DESIGN CAMBER VALUES LISTED IN THE TABLE ARE BASED ON EMPIRICAL FORMULAS AND AS SUCH ARE APPROXIMATE. FOR MEMBERS WITH SPAN-TO-DEPTH RATIOS AT OR EXCEEDING 25, THE TOLERANCE VALUES LISTED IN APPENDIX B OF PCI MANUAL FOR QUALITY CONTROL, MNL-116, MAY NOT APPLY.
 MEASUREMENT OF CAMBER FOR COMPARISON TO PREDICTED DESIGN VALUES SHOULD BE COMPLETED WITHIN 72 HOURS OF RELEASE. ADDITIONALLY, CAMBER SHOULD BE EVALUATED UNDER CONDITIONS THAT MINIMIZE THE EFFECT OF TEMPERATURE VARIATION.

- DESIGNER, FABRICATOR, AND ERECTOR SHALL BE AWARE THAT SKEWED END BEAMS MAY TWIST OR WARP, CAUSING UNEVEN BEAM SEATING AT THE BEARINGS. THE CONTRACTOR IS REQUIRED TO CORRECT AT THE TIME OF ERECTION, BEFORE THE BEAMS ARE SECURED IN PLACE. METHOD OF CORRECTION SHALL PROVIDE AN EVEN, TOTAL BEARING AND A LEVEL TOP BEAM SURFACE. TOLERANCE, AFTER CORRECTION, SHALL BE (+/-) 1/8" INCH. THE FABRICATOR SHALL NOTIFY THE CONTRACTOR AND DESIGNER IF CORRECTIONS ARE REQUIRED PRIOR TO SHIPMENT.
- MAXIMUM BEAM SKEW SHALL BE 30 DEGREES.
- DESIGNER INPUT VALUES OF NUMBER OF INSERTS, DISTANCE FROM END OF BEAM TO ϕ FIRST INSERT, AND ϕ FIRST INSERT TO ϕ SECOND INSERT. ABOVE VALUES SHALL BE BASED ON THE REQUIRED 6'-3" GUARDRAIL POST SPACING ACROSS THE BRIDGE.
- THIS SHEET SHALL BE USED IN CONJUNCTION WITH STANDARD SHEETS BR-B21A, BR-B100, BR-B101, BR-B102A & B, BR-B103, BR-B104, BR-B105A & B AND BR-B106 AS APPLICABLE.

APPROVED: _____ DATE: 10-25-07
 WEST VIRGINIA DEPARTMENT OF TRANSPORTATION
 DIVISION OF HIGHWAYS
 ENGINEERING DIVISION
 DESIGN TABLE FOR 21"
 PRESTRESSED BOX BEAM
 STANDARD SHEET BR-B21B

PREPARED: 07-02-07
 REVIEW: _____

WEST VIRGINIA DEPARTMENT OF TRANSPORTATION
 DIVISION OF HIGHWAYS
 ENGINEERING DIVISION

**SECOND SMITH CREEK BRIDGE
 OVER SMITH CREEK
 IN PENDLETON COUNTY**

DESIGN TABLE FOR 21"
 PRESTRESSED BOX BEAM

DESIGNED BY: TW/	BRIDGE NUMBER
DRAWN BY: THB/	10935
CHECKED BY: TW/	
REVIEWED BY: THB/	
DATE: 1/08	
SCALE:	
SHEET NO. 00 OF 00	

STATE PROJECT NUMBER	FEDERAL PROJECT NUMBER	STATE DIST. NO.	COUNTY	SHEET NO.	TOTAL SHEETS
S336-18-3.77		8	PENDLETON	0	00

GOVERNING SPECIFICATIONS

THE WEST VIRGINIA DEPARTMENT OF TRANSPORTATION, DIVISION OF HIGHWAYS STANDARD SPECIFICATIONS FOR ROADS AND BRIDGES, ADOPTED 2000, AS AMENDED BY THE CURRENT SUPPLEMENTAL SPECIFICATIONS. THE CONTRACT PLANS AND CONTRACT SPECIAL PROVISIONS ARE THE GOVERNING PROVISIONS APPLICABLE TO THIS PROJECT.

ALL BEAMS ARE DESIGNED IN ACCORDANCE WITH THE AASHTO LRFD BRIDGE DESIGN SPECIFICATIONS, DATED 1998 AS AMENDED BY THE 2003 INTERIM SPECIFICATIONS.

DESIGN NOTES

ALL STANDARD ADJACENT PRESTRESSED CONCRETE BRIDGE BEAMS ARE DESIGNED TO MEET THE FOLLOWING CRITERIA:

- DESIGN LOADS:
 - HL-93 LIVE LOAD IN ACCORDANCE WITH THE AASHTO LRFD BRIDGE DESIGN SPECIFICATIONS.
 - FUTURE WEARING SURFACE OF 50 PSF OF ROADWAY.
 - TYPE F PARAPET WEIGHING 321 PLF.
 - DIAPHRAGM DEAD LOAD, NUMBER REQUIRED BASED ON 15'-0" MAX. SPACING.
- TWO LANE BRIDGE WITH AN OVERALL WIDTH OF 24'-5" (INCL. 3/4" GAP BETWEEN ADJ. BEAMS), A CURB-TO-CURB WIDTH OF 22'-1", TRANSVERSE POST-TENSIONING, AND ZERO SKEW.
- DESIGN STRENGTH AND UNIT STRESSES:

MINIMUM CONCRETE STRENGTH @ STRAND RELEASE	6000 PSI
MINIMUM CONCRETE STRENGTH @ 28 DAYS	8000 PSI
TEMPORARY STRESS LIMITS IN CONCRETE BEFORE LOSSES:	
COMPRESSION STRESS LIMIT @ STRAND RELEASE	3600 PSI
TENSION STRESS LIMIT @ STRAND RELEASE	-200 PSI
COMPRESSIVE STRESS LIMITS IN CONCRETE @ SERVICE I AFTER LOSSES:	
@ FINAL 1 (PS+DL+LL)	4800 PSI
@ FINAL 2 (PS+DL)	3600 PSI
@ FINAL 3 [50%(PS+DL)+LL]	3200 PSI
TENSILE STRESS LIMIT IN CONCRETE @ SERVICE III AFTER LOSSES:	
@ FINAL 1 (PS+DL+LL)	-270 PSI
TENDON STRESS LIMIT PRIOR TO TRANSFER:	202.5 KSI
TENDON STRESS LIMIT AFTER ALL LOSSES:	194.4 KSI
- DEBONDING OR SHIELDING OF STRANDS TO REDUCE TEMPORARY TENSILE STRESSES IS PERMITTED, HOWEVER DEBONDING IS LIMITED TO 40% PER ROW AND 25% TOTAL. IN NO INSTANCES SHALL OUTER STRANDS BE DEBONDED. DEBONDED STRANDS SHALL BE SEPARATED BY AT LEAST ONE FULLY BONDED STRAND AND SHALL BE SYMMETRICAL ABOUT THE C OF THE BEAM. SHIELDING OF STRANDS SHALL BE ACCOMPLISHED BY TAPING OR TIGHT FITTING PLASTIC TUBES TAPED AT EACH END.
- THE ELASTOMERIC BEARING PADS PROVIDED IN THE STANDARD DESIGNS ARE BASED ON ZERO GRADE AND ARE LIMITED TO A MAXIMUM OF 5% GRADE. IN INSTANCES OF GRADES EXCEEDING THIS LIMIT, PADS SHALL BE SPECIFICALLY DESIGNED. INDIVIDUAL PAD DESIGNS SHALL BE IN ACCORDANCE WITH SECTION 14, AASHTO LRFD. BEVELED SOLE PLATES ARE PERMITTED.
- MAXIMUM BEAM SKEW SHALL BE 30 DEGREES.
- WHEN ALTERNATE DESIGNS OR SITE SPECIFIC DESIGNS ARE PROVIDED, CRITERIA SET FORTH IN THESE STANDARDS SHALL APPLY.
- NEGATIVE DESIGN CAMBER AFTER ALL LOSSES IS NOT PERMITTED.
- EACH BEAM PROVIDED IN THESE STANDARD DESIGNS HAS BEEN LOAD RATED IN ACCORDANCE WITH SECTION 3.15 OF THE WEST VIRGINIA DIVISION OF HIGHWAYS BRIDGE DESIGN MANUAL, 2004. ADDITIONALLY, LOAD RATING PROCEDURES ARE IN ACCORDANCE WITH THE AASHTO MANUAL FOR CONDITION EVALUATION AND LOAD AND RESISTANCE FACTOR RATING OF HIGHWAY BRIDGES, 2003.

BAR SIZE	NO. 3	NO. 4	NO. 5	NO. 6
SPLICE LEN.	21"	28"	34"	41"

THIS SHEET SHALL BE USED IN CONJUNCTION WITH STANDARD SHEETS BR-B17A & B THRU BR-B42A & B, BR-B101, BR-B102A & B, BR-B103, BR-B104, BR-B105A & B AND BR-B106 AS APPLICABLE.

MATERIALS & FABRICATION NOTES

• THE PRESTRESSED CONCRETE BEAMS SHALL CONFORM TO ALL APPLICABLE PROVISIONS OF SECTION 603 OF THE STANDARD SPECIFICATIONS.

MILD REINFORCEMENT:

- ALL MILD REINFORCING STEEL SHALL BE GRADE 60, DEFORMED BILLET STEEL AND SHALL BE EPOXY COATED EXCEPT WHERE NOTED. ALL UNCOATED REINFORCING SHALL MEET THE REQUIREMENTS OF AASHTO M31. ALL EPOXY COATED REINFORCING SHALL MEET THE REQUIREMENTS OF AASHTO M284, EXCEPT WHERE AMENDED BY SECTION 709.1 OF THE STANDARD SPECIFICATIONS.
- ALL TENSION LAP SPLICES SHALL BE A CLASS B, CONTACT TYPE. MINIMUM LAP SPLICE LENGTHS SHALL BE AS GIVEN IN THE "LAP SPLICE TABLE", THIS SHEET. ADDITIONALLY, IF LAP SPLICING OF ET, LR, AND BT BARS IS USED, TERMINATION OF THE SPLICE SHALL BE NO CLOSER TO THE END OF THE BEAM THAN 1/10 OF THE SPAN LENGTH.
- MINIMUM BAR BENDING DIAMETER SHALL BE 6 BAR DIAMETERS, EXCEPT THAT NO. 4 AB BARS MAY HAVE A MINIMUM BEND DIAMETER OF 4 BAR DIAMETERS.
- MINIMUM CONCRETE COVER SHALL BE AS SPECIFIED IN SECTION 603.5 OF THE STANDARD SPECIFICATIONS, EXCEPT WHERE NOTED ON THE PLANS.

PRESTRESSING STRAND:

- ALL PRESTRESSING STEEL SHALL BE 1/2" #, GRADE 270, 7 WIRE UNCOATED, LOW-RELAXATION STRAND MEETING THE REQUIREMENTS OF AASHTO M203, SUPPLEMENT S1.
- ALL BEAMS DESIGNED IN THESE STANDARDS UTILIZE STRANDS WITH A NOMINAL AREA OF 0.167 SQ. IN. STRANDS WITH A NOMINAL AREA OF 0.153 SQ. IN. IS PERMITTED FOR INDIVIDUAL OR ALTERNATE DESIGNS, HOWEVER THE DESIGNER IS ENCOURAGED TO USE THE LARGER STRAND FOR UNIFORMITY REASONS. IN NO CASES WILL STRESS-RELIEVED STRAND BE PERMITTED.
- ALL STRANDS SHALL BE ENCLOSED INSIDE THE STIRRUP CAGE FOR THE FULL LENGTH OF THE BEAM.
- ALL EXPOSED PRESTRESSING STRAND AT EACH BEAM END SHALL BE SHOP COATED WITH A LIQUID COLD-APPLIED BITUMINOUS ELASTOMERIC WATERPROOFING MEMBRANE. MATERIAL SHALL MEET ASTM C836-84.

CONCRETE:

- ALL CONCRETE USED IN MANUFACTURING PRESTRESSED CONCRETE BEAMS SHALL MEET THE REQUIREMENTS OF SECTION 603.6 OF THE STANDARD SPECIFICATIONS. DESIGN STRENGTHS SHALL MEET OR EXCEED THE MINIMUM VALUES SET FORTH IN THESE PLANS.
- ALL CONCRETE USED IN PARAPETS AND CURBS SHALL BE CLASS K CONCRETE.

ELASTOMERIC BEARING PADS:

- ALL BEARING PADS SHALL MEET THE APPLICABLE REQUIREMENTS AS SET FORTH IN SECTION 18.2 OF THE AASHTO LRFD BRIDGE CONSTRUCTION SPECIFICATIONS, 1998 EDITION WITH CURRENT INTERIMS. ALL BEARINGS SHALL BE STEEL REINFORCED LAMINATED BEARINGS.
- THE ELASTOMER MATERIAL SHALL BE 60 DUROMETERS WITH A MINIMUM LOW TEMPERATURE GRADE OF 3 (ZONE C).
- ALL STEEL REINFORCING SHALL MEET THE REQUIREMENTS OF AASHTO M270, GRADE 36.

GUARDRAIL, GUARDRAIL POSTS, TUBING & INSERTS:

- ALL W-BEAM GUARDRAIL AND ATTACHMENT HARDWARE SHALL BE IN ACCORDANCE WITH SECTION 712.4 OF THE STANDARD SPECIFICATIONS. GUARDRAIL POSTS, STRUCTURAL TUBING, POST ATTACHMENT INSERTS, AND HARDWARE SHALL MEET THE LISTED MATERIAL AND COATING SPECIFICATIONS:

ITEM	DESCRIPTION	MATERIAL SPEC.	COATING SPEC.
POST	W6x25	AASHTO M270, GR 36	AASHTO M111
PLATE	1/2" x 7"	AASHTO M270, GR 36	AASHTO M111
TUBING	TS 8x4x3/16	ASTM A500, GR B	AASHTO M111
CHANNEL	C7x9.8	AASHTO M270, GR 36	AASHTO M111
FERRULE	TYPE 2A 1/4" # x 2 1/2" MIN LEN.	ASTM A108 (11L17 STEEL)	AASHTO M232
WIRE	ANCHOR 3/8" #	ASTM A510 (1018 STEEL)	AASHTO M232
STUDS	1/4" # x 8" LONG	ASTM A108 (1045 C.D. STEEL)	AASHTO M232
NUTS	1/4" #	AASHTO M291, CLASS C	AASHTO M232
COUPLERS	TYPE 1A 1/4" # x 5" LONG	ASTM A108 (12L14 STEEL)	AASHTO M232
BOLTS	ANCHOR 1/4" # x 12" LONG	AASHTO M164 (TYPE 1, HH)	AASHTO M232
BOLTS	5/8" # x ALL LEN.	AASHTO M164 (TYPE 1, HH)	AASHTO M232
NUTS	5/8" #	AASHTO M291, CLASS C	AASHTO M232
WASHERS	ALL	AASHTO M293	AASHTO M232

WELDING:

- TACK WELDING OF REINFORCEMENT IS NOT PERMITTED. REINFORCING CAGES AND LONGITUDINAL STEEL SHALL BE ADEQUATELY TIED WITH APPROVED MEANS TO PREVENT RACKING AND MISALIGNMENT.
- ALL WELDING OF FABRICATED ITEMS, AS SHOWN IN THESE PLANS SHALL BE IN ACCORDANCE WITH ALL APPLICABLE PROVISIONS OF AASHTO/AWS D1.5, 2002.

POST-TENSIONING BARS:

- POST - TENSIONING THREAD BARS SHALL BE ONE INCH DIAMETER, 150 KSI STEEL, AND SHALL CONFORM TO AASHTO M275, TYPE II. STEEL THREAD BARS SHALL BE DESIGNED TO ALLOW THE USE OF HEAVY HEX NUTS AND COUPLERS THAT THREAD ONTO THE END OF THE DEFORMATIONS. HEAVY HEX NUTS AND COUPLERS SHALL BE OF A DESIGN AND MATERIAL RECOMMENDED BY THE BAR MANUFACTURER TO DEVELOP THE FULL TENSILE STRENGTH OF THE BAR. PROPERLY DOCUMENTED CERTIFIED MILL TEST REPORTS SHALL BE PROVIDED FOR EACH HEAT OF STEEL THREAD BARS.
- ALL POST-TENSIONING THREAD BARS, NUTS, BEARING PLATES, COUPLERS, AND ANCILLARY HARDWARE SHALL BE HOT-DIPPED GALVANIZED IN ACCORDANCE WITH AASHTO M111. THE GALVANIZING PLANT SHALL ADMINISTER ADEQUATE QUALITY CONTROL MEASURES TO SAFEGUARD AGAINST HYDROGEN EMBRITTEMENT. QUALITY CONTROL MEASURES SHALL COMPLY WITH ASTM A-143. CERTIFICATION FOR HOT-DIP GALVANIZING SHALL BE PROVIDED BY THE GALVANIZING PLANT.
- ALL POST-TENSIONING BEARING PLATES SHALL CONFORM TO AASHTO M270, GRADE 36.

SHEAR KEY GROUT:

- SHEAR KEY GROUT SHALL BE A GROUT THAT IS RECOMMENDED BY THE MANUFACTURER FOR A POURABLE GROUT APPLICATION AND THAT BASED ON THE MANUFACTURER'S TEST DATA WILL ATTAIN A MINIMUM OF 4500 PSI COMPRESSIVE STRENGTH IN 3 DAYS UNDER CONDITIONS REPRESENTATIVE OF THE CONDITIONS TO BE EXPERIENCED AT THE SITE. THE GROUT MUST BE LISTED ON THE APPROVED LIST OF GROUTS PUBLISHED BY THE WEST VIRGINIA DIVISION OF HIGHWAYS, MATERIALS CONTROL, SOIL AND TESTING DIVISION. THE CONTRACTOR SHALL PRE-TEST THE PROPOSED GROUT FOR COMPRESSIVE STRENGTH AT 3 AND 7 DAYS AND SUBMIT THE RESULTS TO THE BRIDGE PROJECT MANAGER FOR APPROVAL PRIOR TO INSTALLATION OF THE GROUT IN THE STRUCTURE. THE TESTS WILL BE BASED ON A POURABLE CONSISTENCY WITH THE SAME WATER/GROUT MIXTURE RATIO TO BE USED IN THE STRUCTURE.
- THE CONTRACTOR SHALL BE REQUIRED TO SUBMIT FOR EACH PROJECT, THE GROUT PRE-TEST RESULTS OBTAINED IN THE NOTE ABOVE. THE CONTRACTOR SHALL BE REQUIRED TO PERFORM A NEW PRE-TEST AND SUBMISSION FOR APPROVAL UNDER ANY OF THE FOLLOWING CONDITIONS:
 - A PERIOD OF 18 MONTHS HAS ELAPSED SINCE LAST PRE-APPROVAL TESTING.
 - GROUT MANUFACTURER HAS REVISED OR CHANGED THE GROUT SPECIFICATIONS.
 - THE CONTRACTOR ALTERS THE WATER/GROUT MIXTURE RATIO.
 - THE CONTRACTOR CHANGES GROUT MANUFACTURER.
- THE CONTRACTOR IS REQUIRED TO COMPLETE THE GROUT STRENGTH TABLE ON BR-B103.
- TEST PROCEDURE FOR DETERMINING THE COMPRESSIVE STRENGTH OF GROUT SHALL USE CUBE SPECIMENS IN ACCORDANCE WITH ASTM C109, AS MODIFIED BY ASTM C1107. GROUT TESTING IN ACCORDANCE WITH AASHTO T23 (STANDARD CYLINDER TEST) IS NOT ACCEPTABLE.

PROTECTIVE SURFACE TREATMENT:

- EACH PRESTRESSED CONCRETE BEAM SHALL BE TREATED BY THE MANUFACTURER AT THE FABRICATION PLANT WITH AN APPROVED CONCRETE SEALER (SILANE). AN APPROVED LIST OF CONCRETE SEALERS ARE ON FILE AT THE WEST VIRGINIA DIVISION OF HIGHWAYS, MATERIALS CONTROL, SOIL AND TESTING DIVISION. COVERAGE SHALL INCLUDE TOP AND BOTTOM OF INTERIOR BEAMS, AND TOP, BOTTOM AND EXTERIOR SIDE OF EXTERIOR BEAM. APPLICATION RATE SHALL BE PER TREATMENT MANUFACTURER'S RECOMMENDATION.
- AFTER COMPLETION OF THE SILANE TREATMENT BY FABRICATOR AND A MAXIMUM OF FIVE WORKING DAYS PRIOR TO SHIPMENT OF THE BEAMS, THE FABRICATOR SHALL BE RESPONSIBLE FOR ABRASIVE BLAST CLEANING TO CLEAN WHITE CONCRETE THE INTERIOR SIDES OF BEAMS FOR THE FULL LENGTH. CLEAN WHITE CONCRETE SHALL MEAN REMOVAL OF ALL DIRT, GREASE, OIL, AND LOOSE CONCRETE LAITANCE AND PROVIDE A ROUGHENED CONCRETE SURFACE. BLASTING MEDIUM SHALL BE APPROVED BY THE DIVISION OF HIGHWAYS.

SHOP DRAWINGS:

THE FABRICATOR SHALL BE RESPONSIBLE FOR THE PREPARATION OF SHOP DRAWINGS IN ACCORDANCE WITH THE WEST VIRGINIA DIVISION OF HIGHWAYS DOCUMENTS, DD-102 AND THE STANDARD SPECIFICATIONS. ADDITIONAL INFORMATION IS PROVIDED IN SECTION 7 OF THE BRIDGE DESIGN MANUAL. SHOP DRAWINGS SHALL INCLUDE THE FABRICATOR'S DETENSIONING PLAN.

WEST VIRGINIA DEPARTMENT OF TRANSPORTATION DIVISION OF HIGHWAYS ENGINEERING DIVISION		DESIGNED BY: TMB/ DRAWN BY: TMB/ CHECKED BY: TMB/ REVIEWED BY: TW/ DATE: 12/08 SCALE: SHEET NO 0 OF 00 BRIDGE NUMBER 10935
2nd SMITH CREEK BRIDGE OVER SMITH CREEK IN PENDLETON COUNTY		
WEST VIRGINIA DEPARTMENT OF TRANSPORTATION DIVISION OF HIGHWAYS ENGINEERING DIVISION PRESTRESSED CONCRETE BEAM DESIGN & ASSEMBLY NOTES STANDARD SHEET BR-B100		PREPARED BY: TMB DATE: 07-02-07 REVISION:
PRESTRESSED CONCRETE BEAM DESIGN & ASSEMBLY NOTES		

STATE PROJECT NUMBER	FEDERAL PROJECT NUMBER	STATE DIST. NO.	COUNTY	SHEET NO.	TOTAL SHEETS
S336-18-3.77		8	PENDLETON	0	00

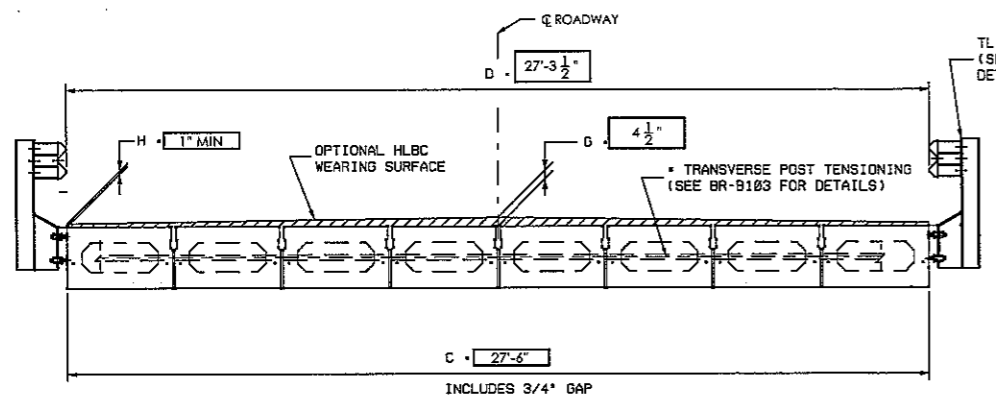

TYPICAL CROSS-SECTION WITH GUARDRAIL

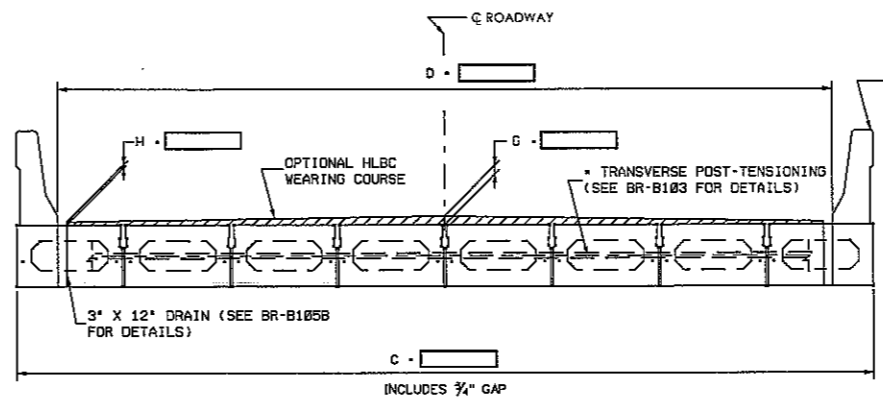

TYPICAL CROSS-SECTION WITH PARAPET OR CURB

CONTROL DIMENSIONS		
DESCRIPTION	CODE	VALUE
OVERALL BEAM LENGTH	A	51'-6"
SPAN LENGTH, @ BEARING TO @ BEARING	B	50'-0"
SUPERSTRUCTURE WIDTH - OUT TO OUT	C	27'-6"
ROADWAY WIDTH - FACE GR/PARAPET TO FACE GR/PARAPET	D	27'-6"
NUMBER OF BEAMS REQUIRED	—	9
BEAM SIZE (WIDTH X DEPTH)	—	36" x 21"
SKEW ANGLE (NORMAL, DEG. RFS OR DEG. LFS)	E	30° RF
PERPENDICULAR DISTANCE FROM FACE OF BEAM TO @ BEARING	F	7 3/4"
HLBC WEARING COURSE REQUIRED (YES/NO)	—	YES
THICKNESS OF WEARING COURSE @ @ OF DECK OR ROADWAY	G	4 1/2"
THICKNESS OF WEARING COURSE @ EDGE OF DECK OR PARAPET	H	1" MIN.
TL-2 BRIDGE GUARDRAIL SYSTEM REQUIRED (YES/NO)	—	YES
FABRICATOR TO SUPPLY TL-2 BRIDGE GUARDRAIL (YES/NO)	—	NO
FABRICATOR TO INSTALL BRIDGE GUARDRAIL PRIOR TO SHIPMENT (YES/NO)	—	NO
NUMBER OF GUARDRAIL POST INSERTS REQUIRED PER SIDE	—	9
TYPE F PARAPET REQUIRED (YES/NO)	—	NO
DRAINS REQUIRED (YES/NO)	—	NO
NUMBER OF DRAINS REQUIRED PER SIDE	—	N/A
10" CURB REQUIRED (YES/NO)	—	NO

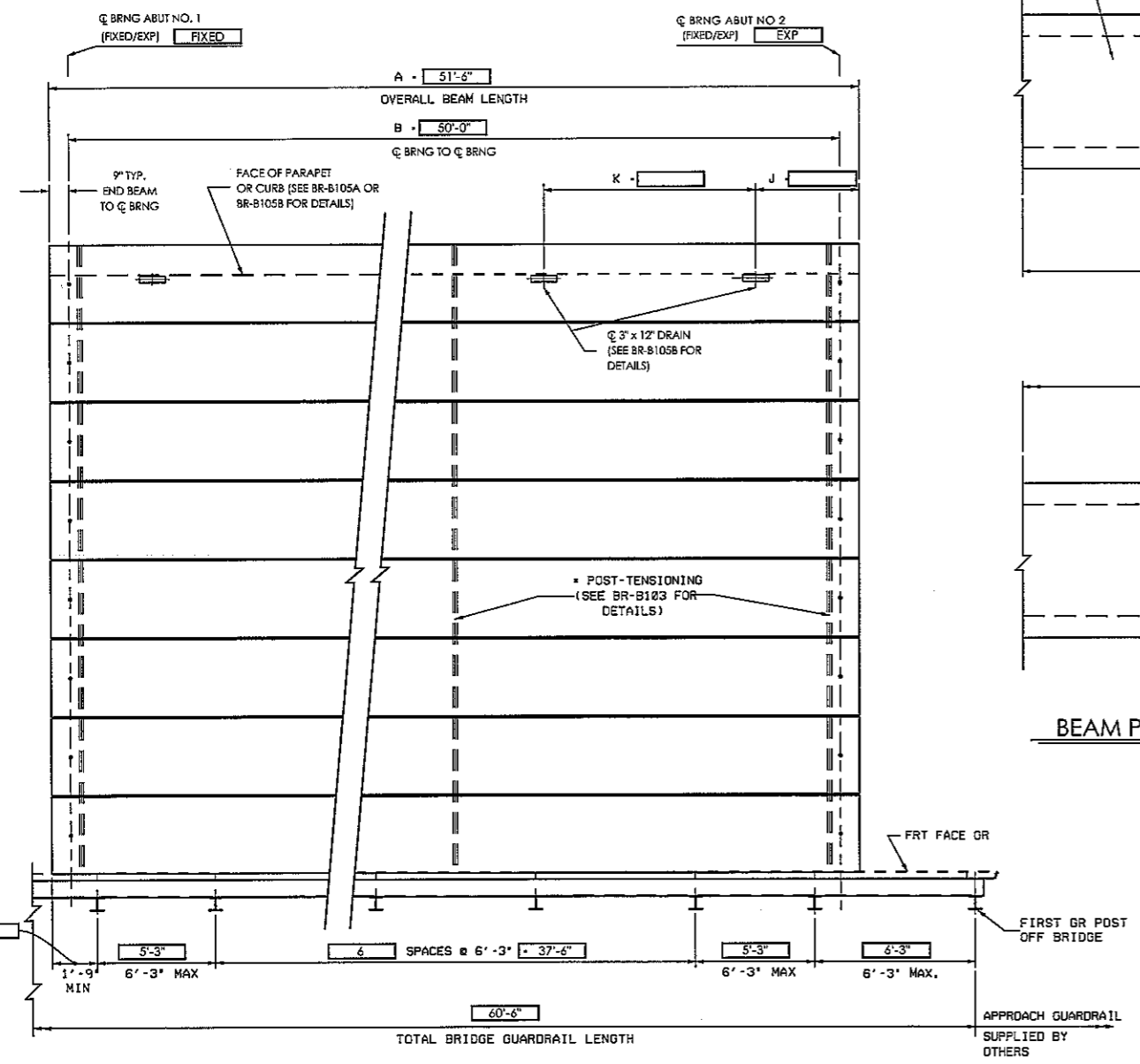

DECK PLAN VIEW

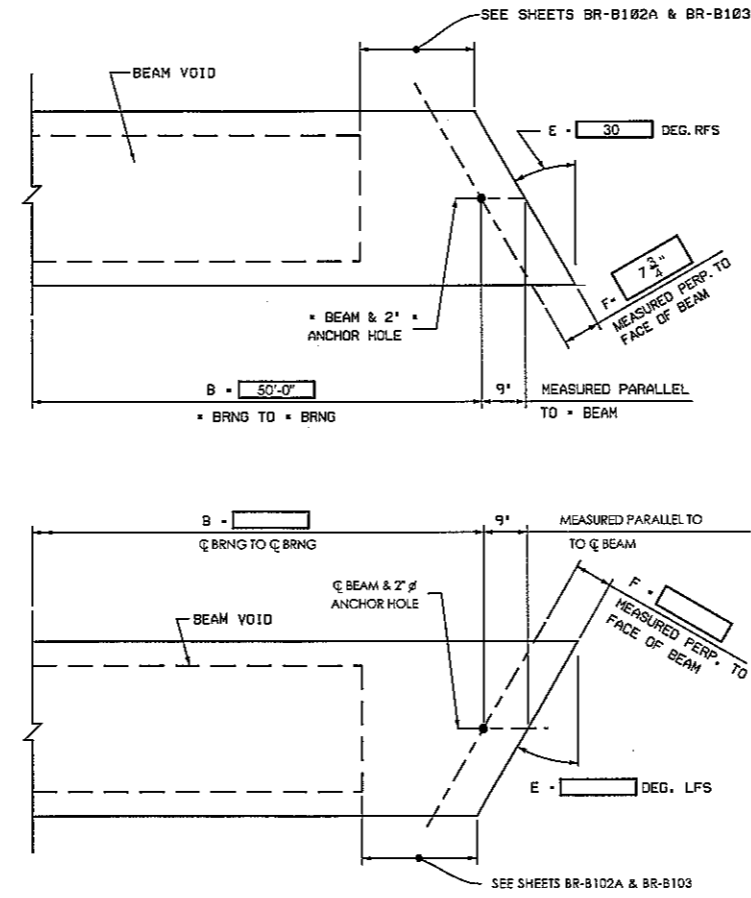

BEAM PLAN VIEW - SKEWED ENDS

ESTIMATE OF QUANTITIES			
ITEM NO.	DESCRIPTION	UNITS	QUANTITY
603016	PRESTRESSED CONCRETE BOX BEAM	LF	463.5

- NOTES:
- WHEN BRIDGE GUARDRAIL IS TO BE SUPPLIED BY THE BEAM FABRICATOR, COST OF ALL BRIDGE GUARDRAIL ITEMS TO INCLUDE POSTS, RAIL ELEMENTS, ATTACHMENT HARDWARE, AND MISCELLANEOUS ITEMS NEEDED TO COMPLETELY INSTALL BRIDGE GUARDRAIL SHALL BE INCLUDED IN ITEM 603016 "PRESTRESSED CONCRETE BOX BEAM."
 - THIS SHEET SHALL BE USED IN CONJUNCTION WITH STANDARD SHEETS BR-B17A & B THRU BR-B42A & B, BR-B100, BR-B102A & B, BR-B103, BR-B104, BR-B105A & B AND BR-B106.

APPROVED: *[Signature]* DATE: 10-25-07
 DIRECTOR, ENGINEERING DIVISION
 WEST VIRGINIA DEPARTMENT OF TRANSPORTATION
 DIVISION OF HIGHWAYS
 ENGINEERING DIVISION
 PREPARED: 07-02-07
 REVISIONS:

 PRESTRESSED CONCRETE BEAM
 DESIGN AND ASSEMBLY NOTES
 STANDARD SHEET BR-B101

WEST VIRGINIA DEPARTMENT OF TRANSPORTATION
 DIVISION OF HIGHWAYS
 ENGINEERING DIVISION
 DESIGNED BY: THB/
 DRAWN BY: THB/
 CHECKED BY: TM/
 REVIEWED BY: TW/
 DATE: 12/08
 SCALE:
 SHEET NO 0 OF 00
 BRIDGE NUMBER
 10935
 2nd SMITH CREEK BRIDGE
 OVER SMITH CREEK
 IN PENDLETON COUNTY
 PRESTRESSED CONCRETE BEAM
 DESIGN & ASSEMBLY NOTES

STATE PROJECT NUMBER	FEDERAL PROJECT NUMBER	STATE DIST. NO.	COUNTY	SHEET NO.	TOTAL SHEETS
S336-18-3.77		8	PENDLETON	0	00

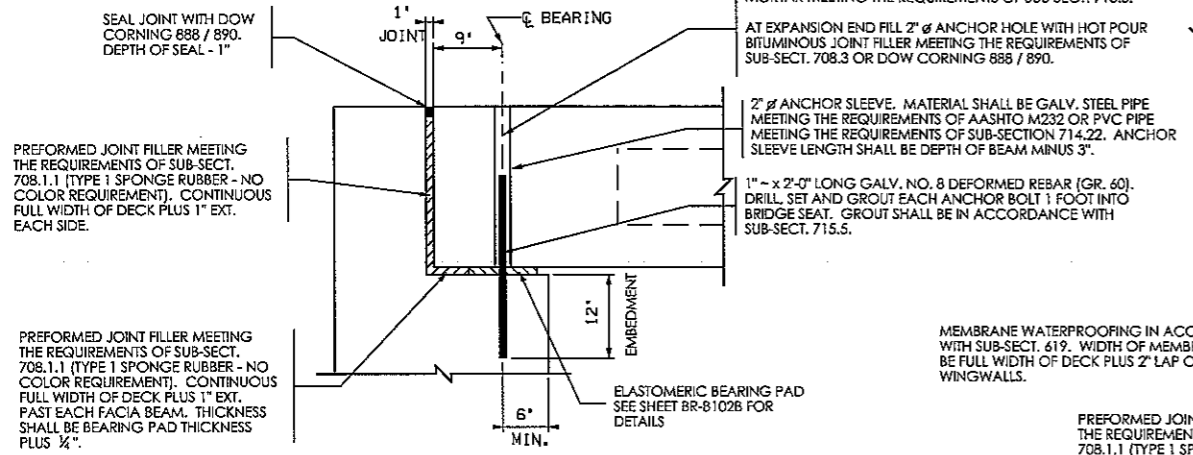

END BEARING DETAIL WITH BACKWALL

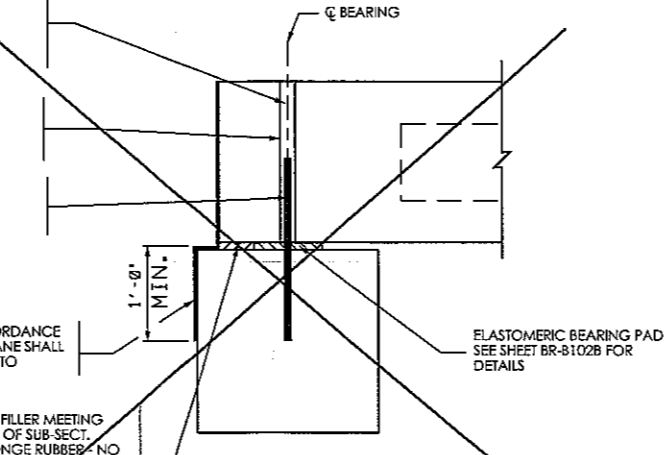

END BEARING DETAIL WITHOUT BACKWALL

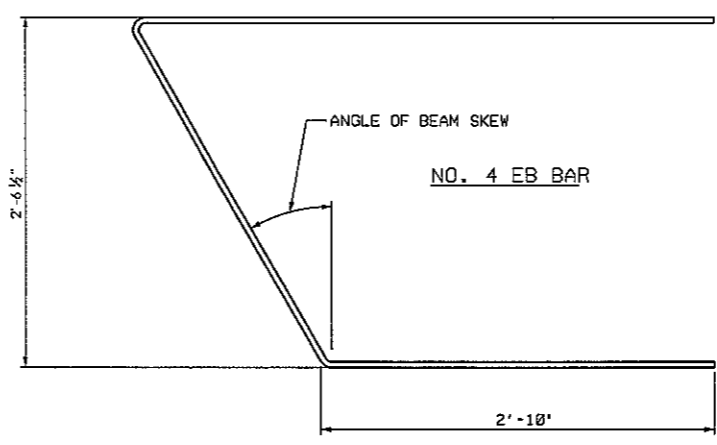
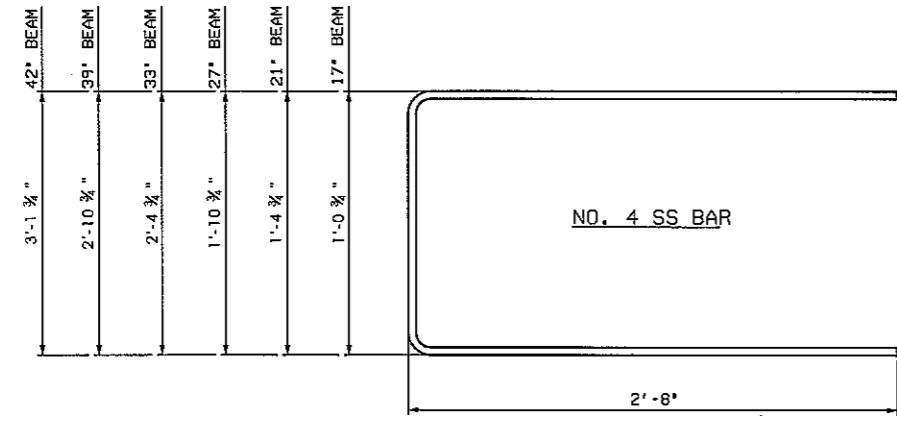

SHEAR KEY DETAIL

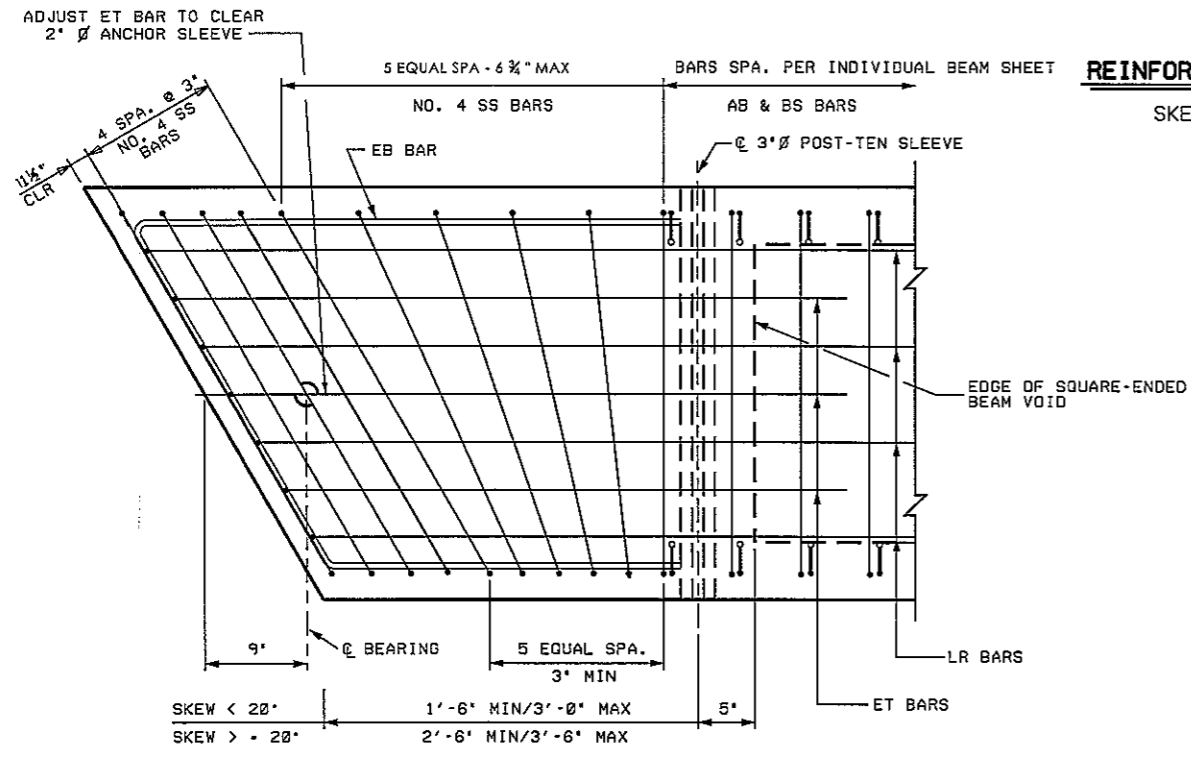

END BLOCK DETAIL - SKEWED BEAMS
WO/POST-TEN. ACCESS POCKET

THIS SHEET SHALL BE USED IN CONJUNCTION WITH STANDARD SHEETS BR-817A & B THRU BR-842A & B, BR-8100, BR-8101, BR-8102B, BR-8103, BR-8104, BR-8105A & B AND BR-8106 AS APPROPRIATE.

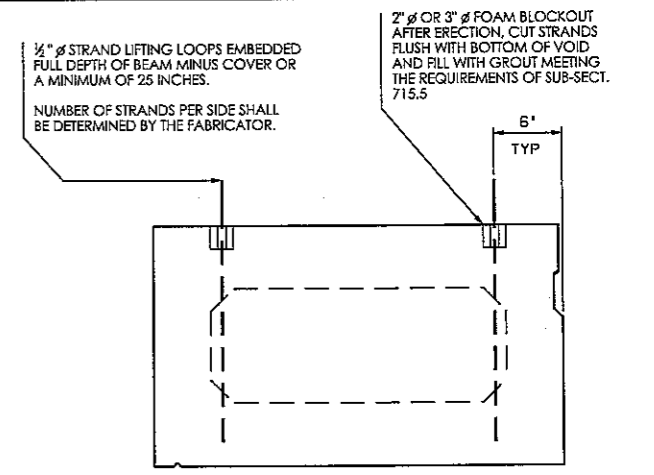

END VIEW

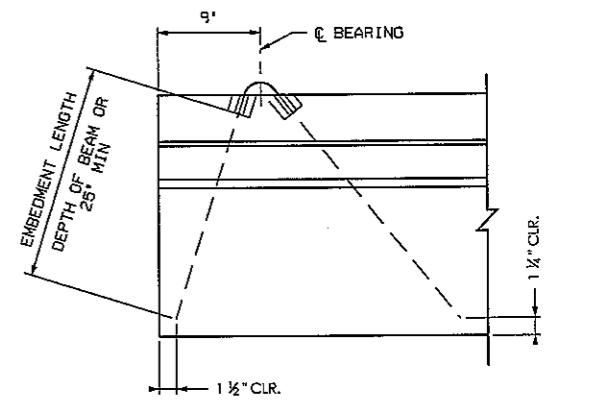

SIDE VIEW

LIFTING DETAILS

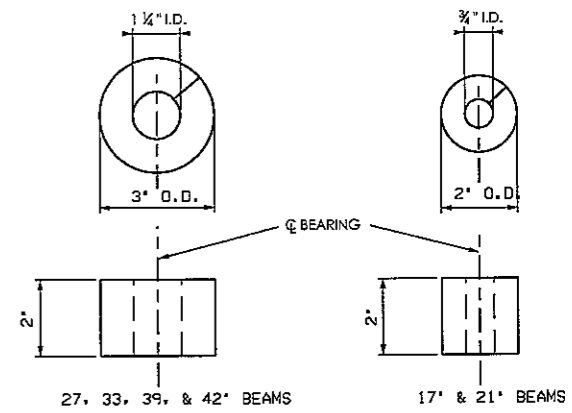

BLOCKOUT DETAILS

WEST VIRGINIA DEPARTMENT OF TRANSPORTATION
DIVISION OF HIGHWAYS
ENGINEERING DIVISION

**2nd SMITH CREEK BRIDGE
OVER SMITH CREEK
IN PENDLETON COUNTY**

PRESTRESSED CONCRETE BEAM
SKEWED END REINFORCING
MISC. DESIGN AND ASSEMBLY DETAILS

DESIGNED BY: THB/
DRAWN BY: THB/
CHECKED BY: TM/
REVIEWED BY: TW/
DATE: 12/08
SCALE:
SHEET 0 OF 00
BRIDGE NO. 10935

APPROVED: <i>Gregory Bailey</i> DIRECTOR, ENGINEERING DIVISION	DATE: 10-25-07
WEST VIRGINIA DEPARTMENT OF TRANSPORTATION DIVISION OF HIGHWAYS ENGINEERING DIVISION	PREPARED: 07-02-07
PRESTRESSED CONCRETE BEAM SKEWED END REINFORCING MISC. DESIGN AND ASSEMBLY DETAILS	REVISION:
STANDARD SHEET BR-8102A	

STATE PROJECT NUMBER	FEDERAL PROJECT NUMBER	STATE DIST. NO.	COUNTY	SHEET NO.	TOTAL SHEETS
S336-18-3.77		8	PENDELTON	0	00

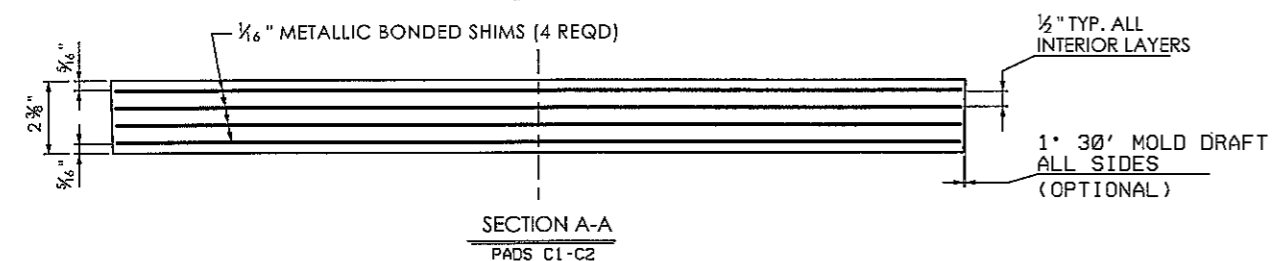
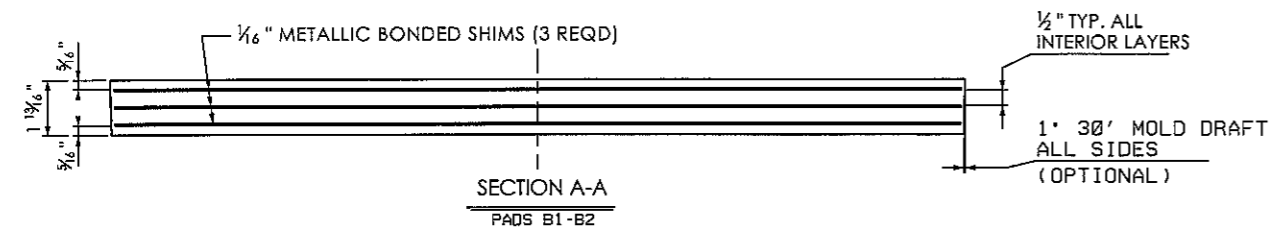
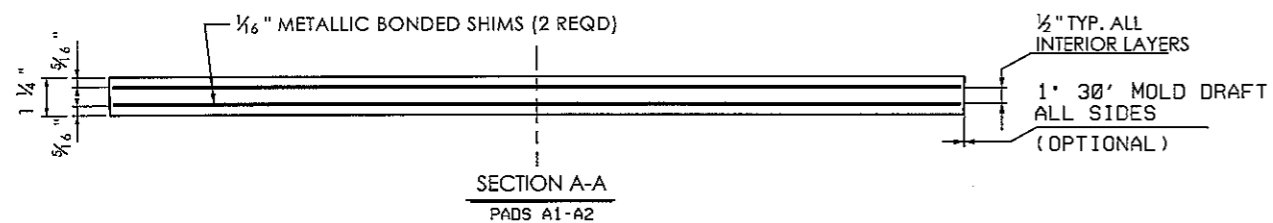
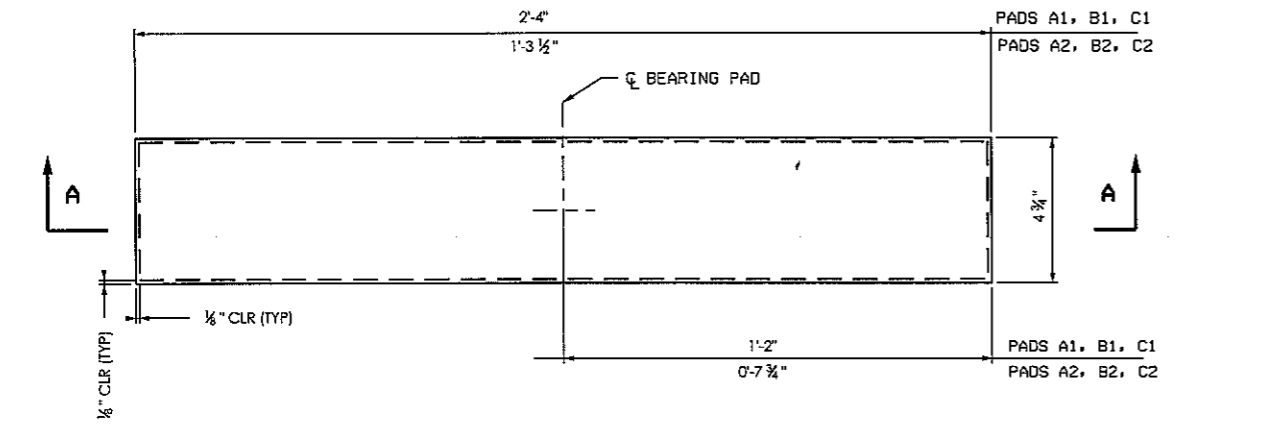

PERFORMED JOINT FILLER MEETING THE REQUIREMENTS OF SUB-SECT. 708.1.1 (TYPE 1 SPONGE RUBBER - NO COLOR REQUIREMENTS). THICKNESS SHALL BE BEARING PAD THICKNESS PLUS 1/4". (TYPICAL)

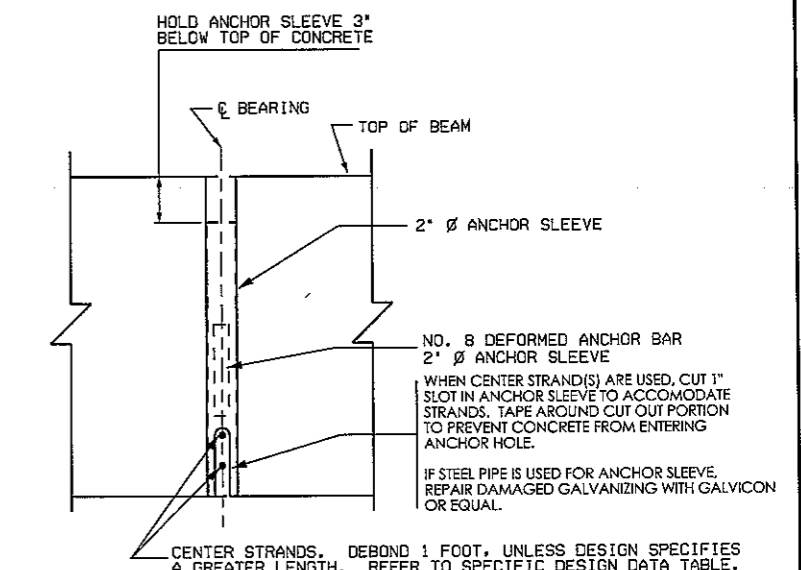
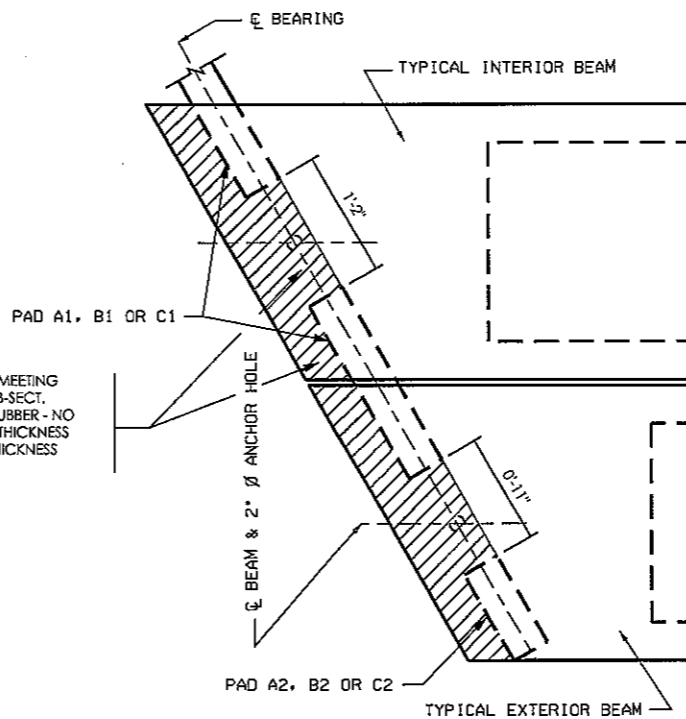
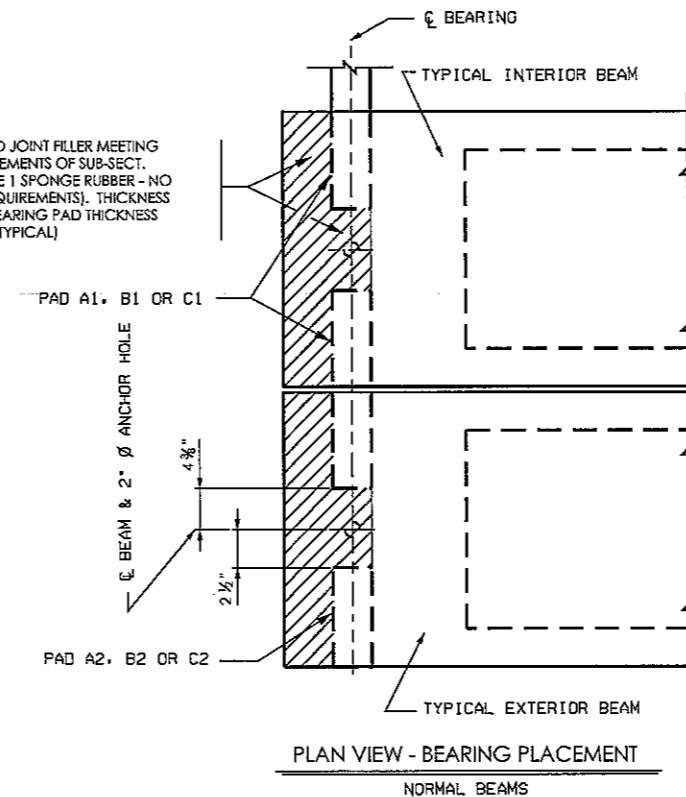

ANCHOR SLEEVE DETAIL

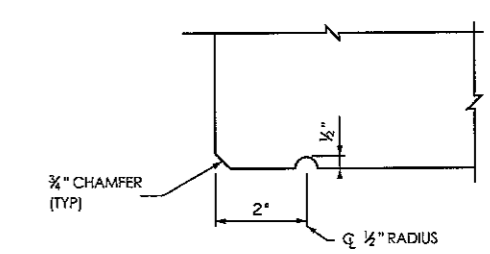

DRIP GROOVE DETAIL EXTERIOR BEAMS

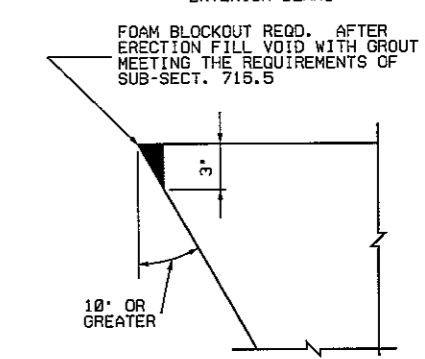

SKEW BLOCKOUT DETAIL

NOTES:

- ELASTOMERIC BEARING PADS ARE DESIGNED IN ACCORDANCE WITH DESIGN METHOD B CONTAINED IN SECTION 14 OF THE AASHTO LRFD BRIDGE DESIGN SPECIFICATIONS. FABRICATION SHALL BE IN ACCORDANCE WITH SECTION 18 OF THE AASHTO LRFD BRIDGE CONSTRUCTION SPECIFICATIONS.
- ALL BEARINGS ARE DESIGNED FOR A LOW TEMPERATURE ZONE C AND SHALL HAVE A DUROMETER HARDNESS OF 60. METALLIC REINFORCEMENT SHALL HAVE A MINIMUM YIELD STRENGTH OF 36 KSI.
- BEARING PADS ARE DESIGNED FOR ZERO BRIDGE GRADE. FOR BRIDGE GRADES GREATER THAN 5%, PADS SHALL BE SPECIFICALLY DESIGNED FOR THE GRADE. AS AN ALTERNATE, CAST-IN-PLACE BEVELED SOLE PLATES MAY BE USED.
- DESIGNER, FABRICATOR AND ERECTOR SHALL BE AWARE THAT SKEWED END BEAMS MAY TWIST OR WARP, CAUSING UNEVEN BEAM SEATING AT THE BEARINGS. THE CONTRACTOR IS REQUIRED TO CORRECT AT THE TIME OF ERECTION, BEFORE THE BEAMS ARE SECURED IN PLACE. METHOD OF CORRECTION SHALL PROVIDE AN EVEN, TOTAL BEARING AND A LEVEL TOP BEAM SURFACE. TOLERANCE AFTER CORRECTION SHALL BE 1/8 INCH. THE FABRICATOR SHALL NOTIFY THE CONTRACTOR AND DESIGNER IF CORRECTIONS ARE REQUIRED PRIOR TO SHIPMENT.
- FOR BEAMS WITH STEPPED ENDS USE PADS A2, B2, OR C2 ON BOTH SIDES OF EACH BEAM.
- ELASTOMERIC BEARING PADS SHALL BE INCLUDED IN THE PRICE OF THE BEAMS.
- THIS SHEET SHALL BE USED IN CONJUNCTION WITH STANDARD SHEETS BR-B17A & B THRU BR-B42A & B, BR-B100, BR-B101, BR-B102A, BR-B103, BR-B104, BR-B105A & B AND BR-106 AS APPROPRIATE.

BOX BEAM BEARING PAD CONTROL DIMENSIONS								
PAD	LENGTH	WIDTH	HEIGHT	NO. SHIMS	SHIM SIZE	SPAN RANGES	MAXIMUM REACTION	MAXIMUM MOVEMENT ONE DIRECTION
A1	4 3/4"	28"	1 1/4"	2	1/16" x 4 1/2" x 2'-3 3/4"	20' - 38'	55 KIPS	0.39"
B1	4 3/4"	28"	1 13/16"	3	1/16" x 4 1/2" x 2'-3 3/4"	40' - 78'	75 KIPS	0.80"
C1	4 3/4"	28"	2 3/8"	4	1/16" x 4 1/2" x 2'-3 3/4"	80' - 100'	89 KIPS	1.02"
A2	4 3/4"	15 1/2"	1 1/4"	2	1/16" x 4 1/2" x 1'-3 1/4"	20' - 38'	28 KIPS	0.39"
B2	4 3/4"	15 1/2"	1 13/16"	3	1/16" x 4 1/2" x 1'-3 1/4"	40' - 78'	38 KIPS	0.80"
C2	4 3/4"	15 1/2"	2 3/8"	4	1/16" x 4 1/2" x 1'-3 1/4"	80' - 100'	45 KIPS	1.02"

PLAN VIEW - BEARING PLACEMENT

APPROVED: *Gregory Bailey* DIRECTOR, ENGINEERING DIVISION DATE: 10-25-07

WEST VIRGINIA DEPARTMENT OF TRANSPORTATION DIVISION OF HIGHWAYS ENGINEERING DIVISION

PREPARED: 07-02-07

REVISIONS:

PRESTRESSED CONCRETE BEAM ELASTOMERIC BEARING PAD DETAILS MISC. DESIGN AND ASSEMBLY DETAILS

STANDARD SHEET BR-B102B

WEST VIRGINIA DEPARTMENT OF TRANSPORTATION DIVISION OF HIGHWAYS ENGINEERING DIVISION

DESIGNED BY: THB/

DRAWN BY: THB/

CHECKED BY: TM/

REVIEWED BY: THB/

DATE: 12/08

SCALE:

SHEET 0 OF 00

BRIDGE NO. 10935

2nd SMITH CREEK BRIDGE OVER SMITH CREEK IN PENDELTON COUNTY

PRESTRESSED CONCRETE BEAM ELASTOMERIC BEARING PAD DETAILS MISC. DESIGN AND ASSEMBLY DETAILS

STATE PROJECT NUMBER	FEDERAL PROJECT NUMBER	STATE DIST. NO.	COUNTY	SHEET NO.	TOTAL SHEETS
S336-18-3.77		8	PENDLETON	0	00

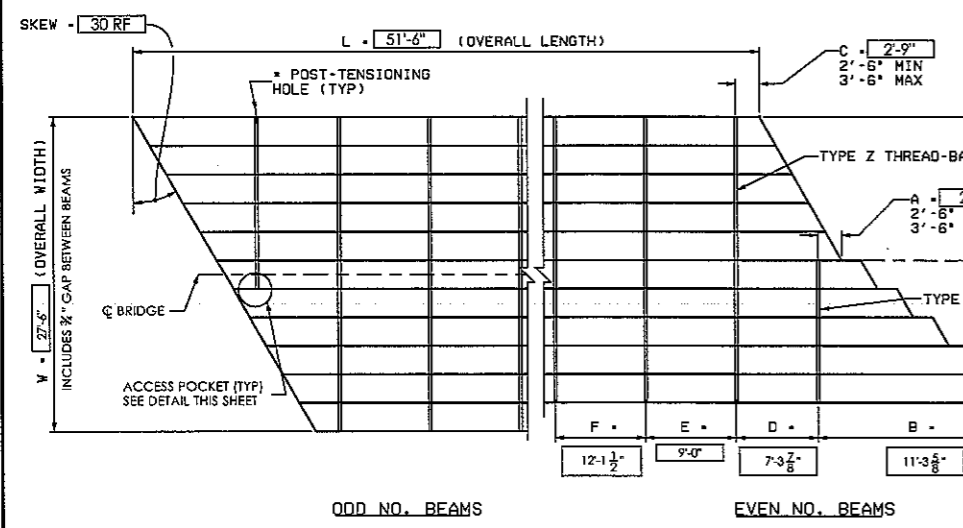

POST-TENSIONING BAR SPACING PLAN
SKEW > 20°

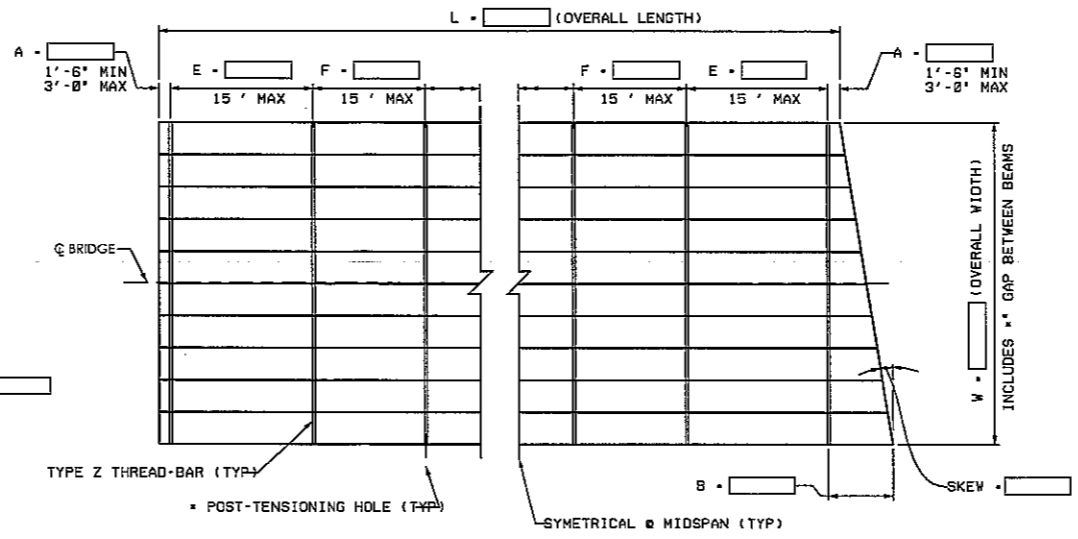

POST-TENSIONING BAR SPACING PLAN
NORMAL OR SKEW < 20°

REFER TO STANDARD SHEET BR-B102A FOR SHEAR KEY DETAILS.

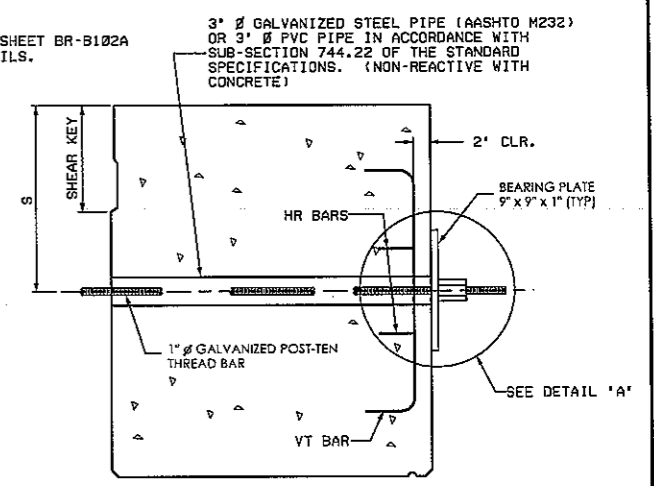

POST-TENSIONING BAR DETAILS

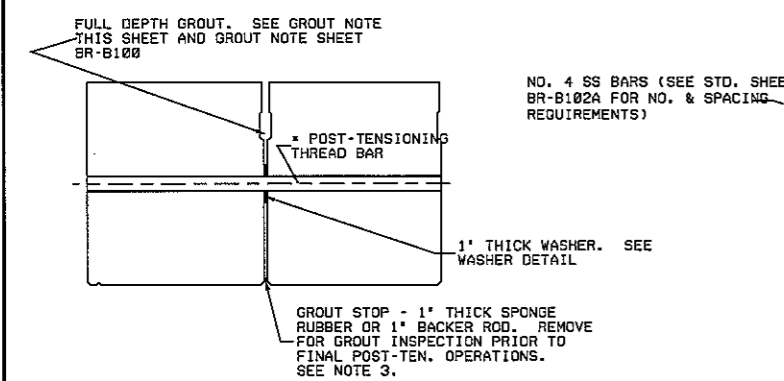

GROUT DETAILS

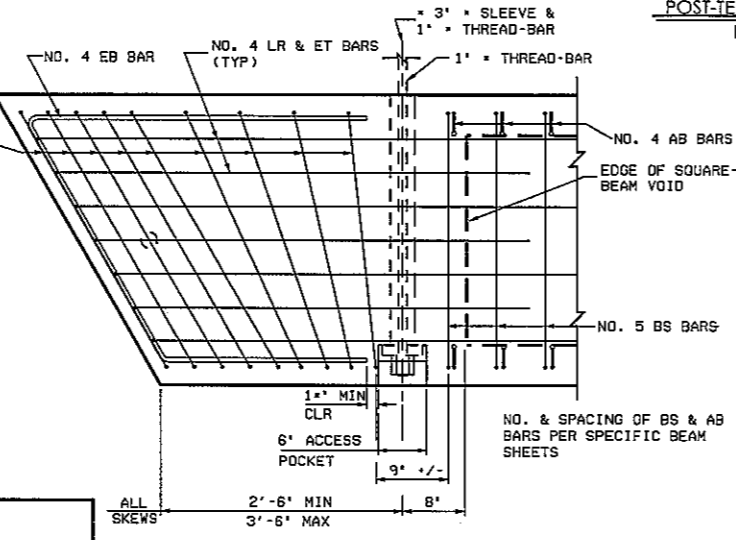

SHEAR REINFORCEMENT DETAIL
BEAMS WITH ACCESS POCKETS

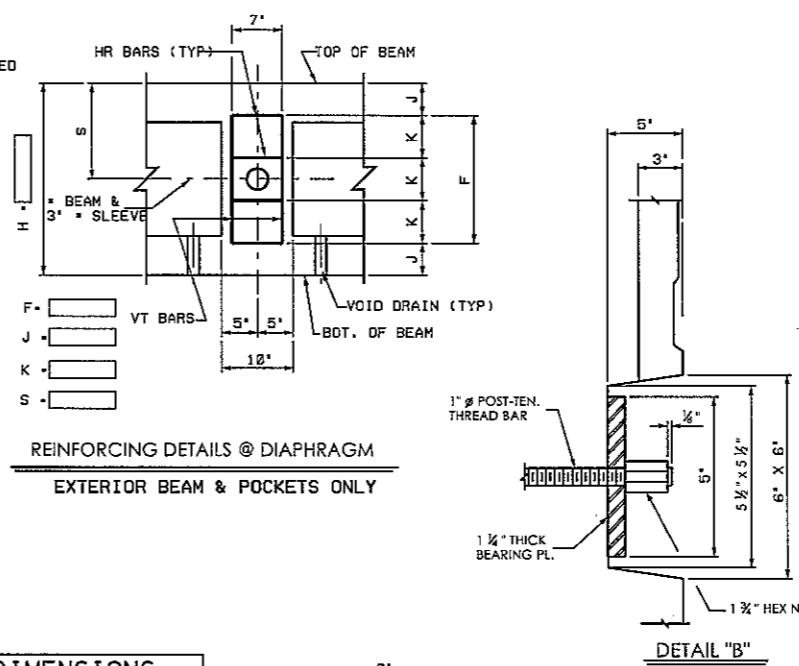

REINFORCING DETAILS @ DIAPHRAGM
EXTERIOR BEAM & POCKETS ONLY

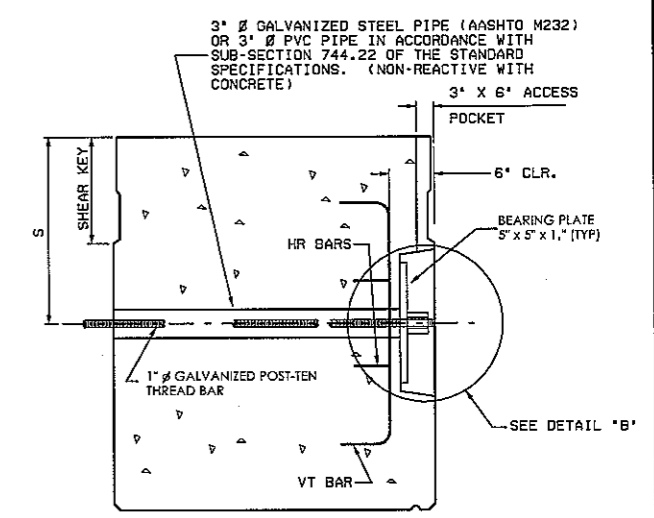

ACCESS POCKET, END POST-TENSIONING BAR

- PROCEDURE NOTES**
- INSTALL ONE INCH THICK WASHER AND GROUT STOP BY GLUING TO ONE SIDE, FOR THE ENTIRE LENGTH OF EACH BEAM PRIOR TO SETTING BEAMS. GLUE SHALL BE AN APPROVED CONSTRUCTION TYPE GLUE OR EPOXY ADHESIVE. GROUT STOP MAY BE INSTALLED AFTER BEAMS ARE SET.
 - GLUE A 1/2" x 2" x 2" PIECE OF PRESSURE TREATED PLYWOOD AT EACH THREAD-BAR LOCATION TO INSURE THAT A 1/2" GAP IS OBTAINED. PLYWOOD SPACERS TO BE OFFSET APPROXIMATELY 2 FEET FROM THE THREAD-BAR HOLE AND CENTERED ON THE HOLE DEPTH. PLYWOOD SPACERS ARE REQUIRED ON ONLY ONE BEAM EDGE FACE OF ABUTTING BEAMS. AFTER THE BEAMS ARE SET AND THE THREAD-BARS INSTALLED, FULL THE ENTIRE SUPERSTRUCTURE TOGETHER BY APPLYING A POST-TENSIONING FORCE OF APPROXIMATELY 3000 POUNDS, AT THIS STAGE THE GAP BETWEEN BEAMS SHALL BE A UNIFORM 1/4" WITH ALL SWEEP REMOVED. RECORD THE ACTUAL FORCE APPLIED.
 - FILL THE GAP BETWEEN BEAMS AND SHEAR KEY FULL DEPTH WITH THE PRE-APPROVED, PRE-TESTED GROUT MIXTURE. FROM EACH BATCH, PREPARE JOB CONTROL GROUT CUBES FOR THREE AND SEVEN DAY TESTS. THESE JOB CONTROL SAMPLES WILL BE USED TO DETERMINE WHEN THE GROUT HAS ATTAINED A MINIMUM COMPRESSIVE STRENGTH OF 4500 PSI. A MINIMUM OF THREE SPECIMENS PER TEST SHALL BE OBTAINED, AND THE AVERAGE OF THE TEST RESULTS USED. ACCEPTANCE SAMPLING AND TESTING OF THE GROUT IS THE RESPONSIBILITY OF THE CONTRACTOR; HOWEVER, A REPRESENTATIVE OF THE WVDOT SHALL WITNESS ALL OF THE ACCEPTANCE SAMPLING AND TESTING.

TEST PROCEDURE SHALL BE ASTM C109 AS MODIFIED BY ASTM C1107. IN NO INSTANCE SHALL THE CONTRACTOR PROCEED WITH POST-TENSIONING OR OTHER BEAM ERECTION PROCEDURES UNTIL THE REQUIRED MINIMUM GROUT STRENGTH IS ATTAINED AND VERIFIED BY THE ENGINEER. IN THE EVENT THAT THE MINIMUM GROUT STRENGTH IS NOT ATTAINED, THE ENGINEER SHALL BE NOTIFIED AND CORRECTIVE ACTION TAKEN AT THE DIRECTION OF THE ENGINEER. SEE SHEAR KEY GROUT NOTE, SHEET BR-B100 FOR ADDITIONAL REQUIREMENTS.

AFTER THE GROUT HAS REACHED AN INITIAL SET CONDITION AND PRIOR TO ANY FINAL POST-TENSIONING PROCEDURES, THE CONTRACTOR SHALL REMOVE THE GROUT STOP AND INSPECT THE GROUT FOR VOIDS OR OTHER IRREGULARITIES. ANY VOIDS DEEPER THAN 2" FROM THE BOTTOM SHALL BE REGROUTED IN A MANNER ACCEPTABLE TO THE ENGINEER.
 - AFTER GROUT AS BEEN PLACED AND REACHED ITS MINIMUM COMPRESSIVE STRENGTH OF 4500 PSI AND HAS CURED A MINIMUM OF 3 DAYS, APPLY 50% OF THE FINAL POST-TENSIONING FORCE TO ALL THREAD-BARS, WORKING BEAM ENDS TO MIDSPAN. AFTER ALL THREAD-BARS HAVE BEEN TENSIONED TO 50%, APPLY THE REMAINING PERCENTAGE OF FINAL POST-TENSIONING FORCE, WORKING IN THE SAME SEQUENCE AS THE FIRST STAGE OF FINAL TENSIONING.
 - MEASURE AND RECORD, IN THE ELONGATION TABLE, THIS SHEET, THE ACTUAL TOTAL ELONGATION OF EACH THREAD-BAR. COMPARE THE MEASURED ELONGATION TO THE CALCULATED ELONGATION. A SIGNIFICANT DIFFERENCE BETWEEN MEASURED AND CALCULATED ELONGATIONS COULD INDICATE IMPROPER JACKING TECHNIQUES, FAULTY MATERIALS, FAULTY JACKS, OR IMPROPERLY CALIBRATED JACKS. IF THE DIFFERENCE IS GREATER THAN 15%, THEN THE JACK SHALL BE RE-CALIBRATED AND THE JACKING TECHNIQUES EVALUATED. IF, AFTER THE ABOVE STEPS ARE TAKEN, THE PERCENTAGE DIFFERENCE IS GREATER THAN 10%, THEN THE ENGINEER SHALL BE NOTIFIED AND CORRECTIVE ACTION TAKEN AT THE DIRECTION OF THE ENGINEER. ALL COSTS INVOLVED IN CORRECTION SHALL BE AT THE CONTRACTORS EXPENSE.
 - USING SAW, TRIM EXCESS THREAD-BAR LEAVING 4" TO 6" PAST THE NUT. DO NOT TRIM THREAD-BARS BY TORCH CUTTING. TOUCH-UP TRIMMED ENDS WITH GALVICON OR EQUAL.
 - INSTALL ANCHOR DOWELS AS DETAILED ON STANDARD SHEETS BR-B101 AND BR-B102A.

FINAL POST-TENSIONING FORCE
TYPE Z BARS = 80 KIPS
TYPE V BARS = 40 KIPS

SPAN	50'-0"
SKEW	30° RF
L	51'-6"
W	27'-6"
A	2'-6"
B	11'-3 3/8"
C	2'-9"
D	7'-3 3/8"
E	9'-0"
F	
STEP	

BEAM SIZE	REINFORCEMENT DIM	BAR SPACING	BAR DIST
H	F	J	K
IN.	IN.	IN.	IN.
17	12	2 1/2	4
21	12	4 1/2	4
27	18	4 1/2	6
33	24	4 1/2	8
39	30	4 1/2	10
42	33	4 1/2	11

PRE-TEST STRENGTH	3 DAY (PSI)	7 DAY (PSI)
JOB CONTROL STRENGTH		
GROUT TYPE & MANUFACTURER		

BAR	FORMULA	LENGTH
V(EVEN)	W-3'	30'-6"
Z	W+3'	30'-6"
V(ODD)	W/2+4'-6"	18'-3"

BAR	CODE	CALC.	MEASURED												
			NO. 1	NO. 2	NO. 3	NO. 4	NO. 5	NO. 6	NO. 7	NO. 8	NO. 9	NO. 10			
Z	⊗	1.11"													
V	⊙	0.28"													

CALCULATED ⊗ = W(F.T.) / 24.8
CALCULATED ⊙ = W(F.T.) / 99.2

- SPECIAL WARNING NOTES**
- DO NOT STAND IN LINE WITH THE POST-TENSIONING BAR DURING TENSIONING PROCEDURES.
 - NUTS, COUPLERS AND EXTENSION RODS USED IN THE POST-TENSIONING WORK SHALL BE THE MATERIAL APPROVED BY THE MANUFACTURER OF THE HIGH STRENGTH POST-TENSIONING RODS. IN NO CASE SHALL THE CONTRACTOR USE NON-APPROVED MATERIAL OR MATERIAL FROM TWO DIFFERENT SOURCES.

WEST VIRGINIA DEPARTMENT OF TRANSPORTATION
DIVISION OF HIGHWAYS
ENGINEERING DIVISION

PRESTRESSED CONCRETE BEAM
TRANSVERSE POST-TENSIONING DETAILS
STANDARD SHEET BR-B103

DATE: 10-25-07
PREPARED: 07-02-07

WEST VIRGINIA DEPARTMENT OF TRANSPORTATION
DIVISION OF HIGHWAYS
ENGINEERING DIVISION

2nd SMITH CREEK BRIDGE
OVER SMITH CREEK
IN PENDLETON COUNTY

DESIGNED BY: THB/
DRAWN BY: THB/
CHECKED BY: THW/
REVIEWED BY: TW/
DATE: 12/08
SCALE:
SHEET NO 00 OF 00
BRIDGE NUMBER
10935

PRESTRESSED CONCRETE BEAM
TRANSVERSE POST-TENSIONING DETAILS

STATE PROJECT NUMBER	FEDERAL PROJECT NUMBER	STATE DIST. NO.	COUNTY	SHEET NO.	TOTAL SHEETS
S336-18-3.77		8	PENDLETON	0	00

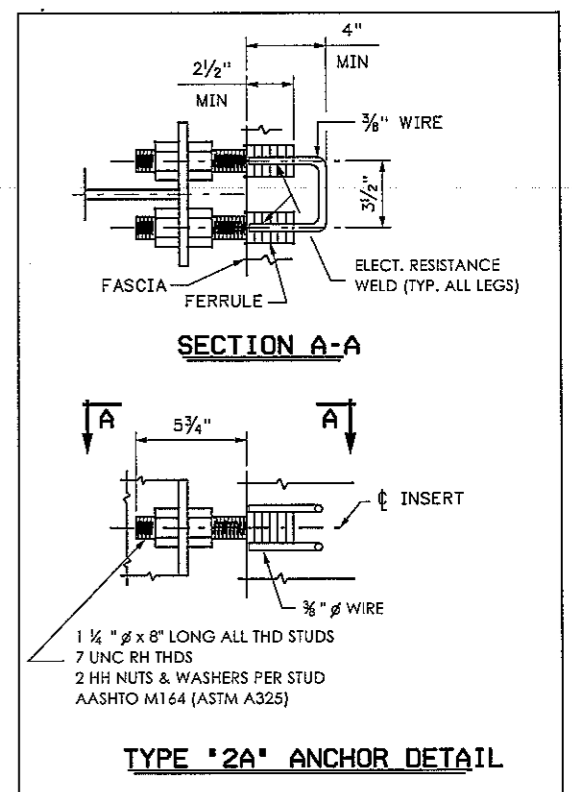
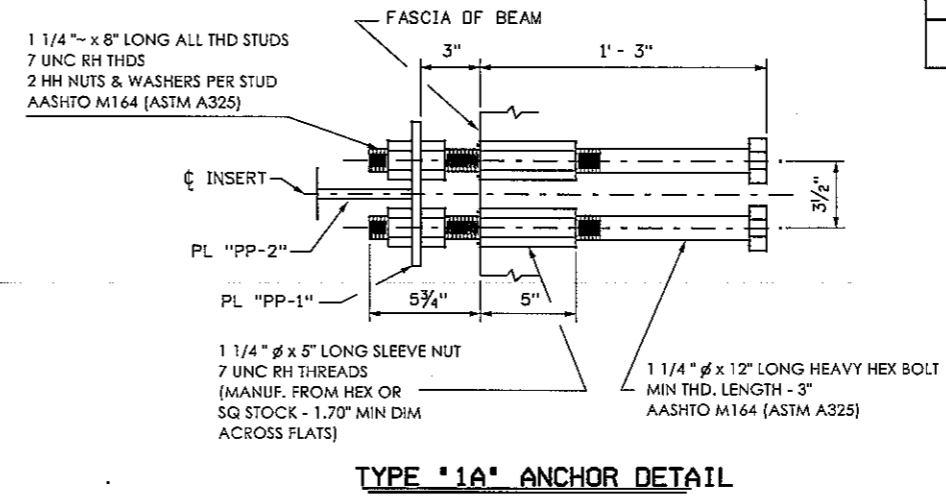
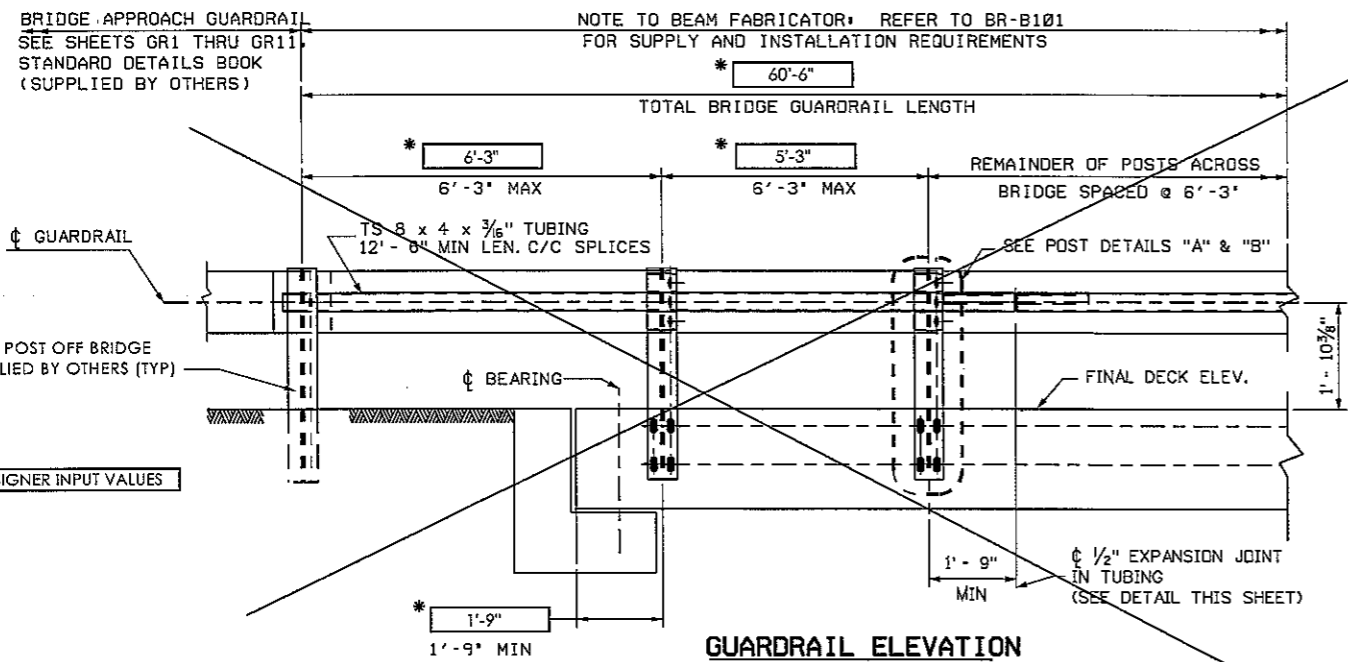

NOTE: GUARDRAIL NOT INCLUDED ON SCO
ANCHORS INCLUDED IN BEAM PRICES

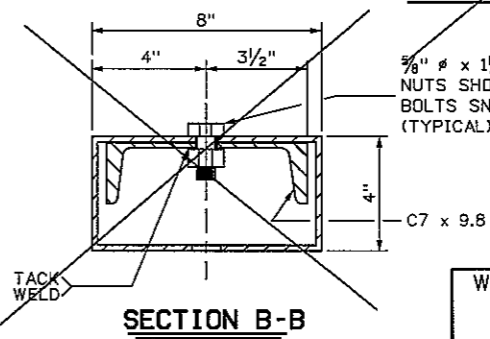
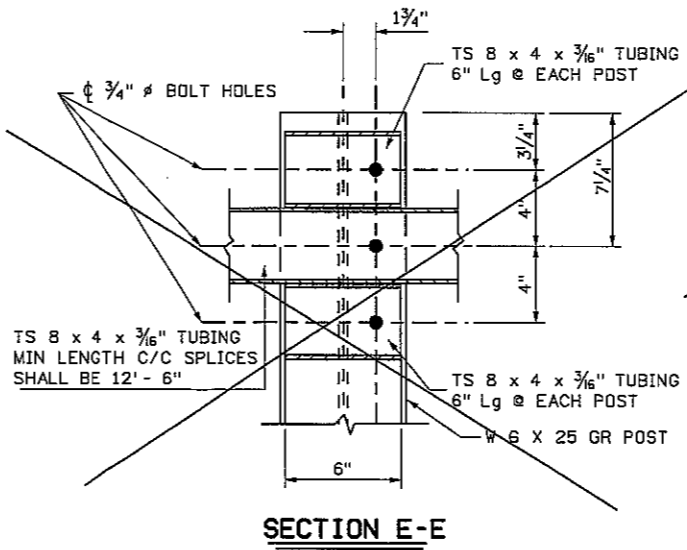
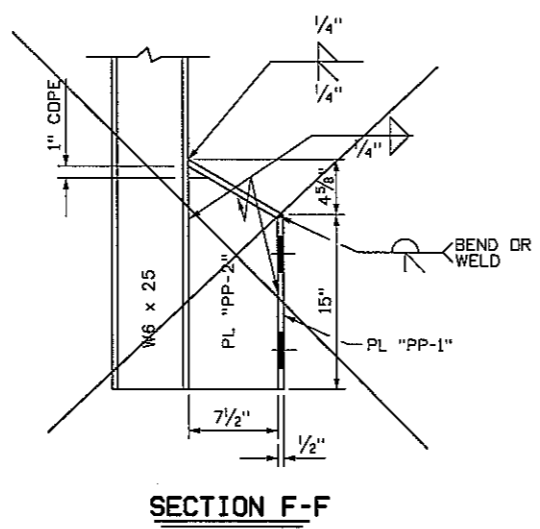
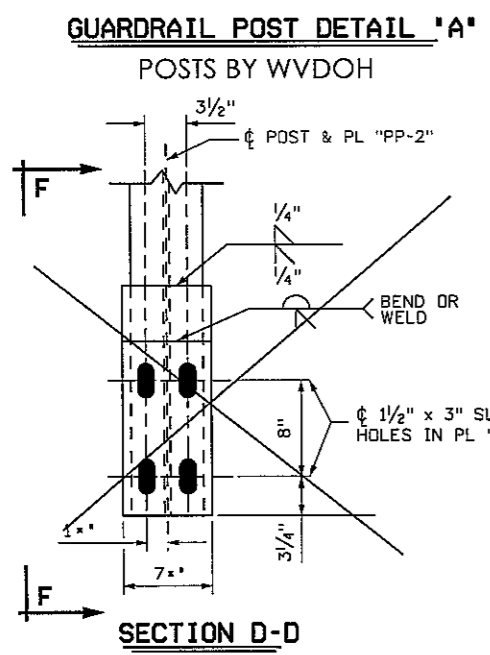
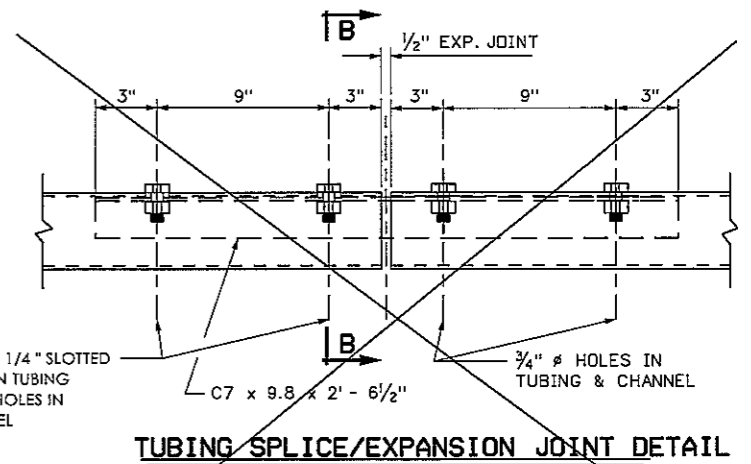
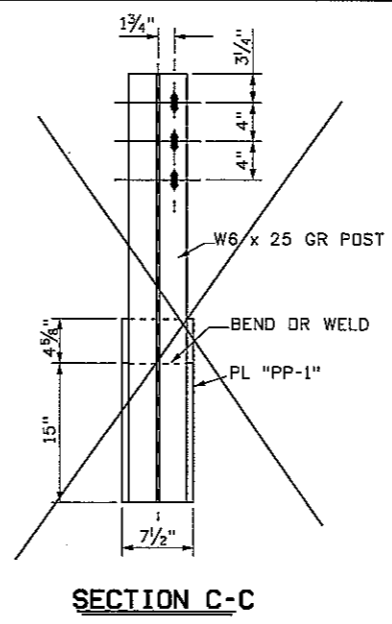
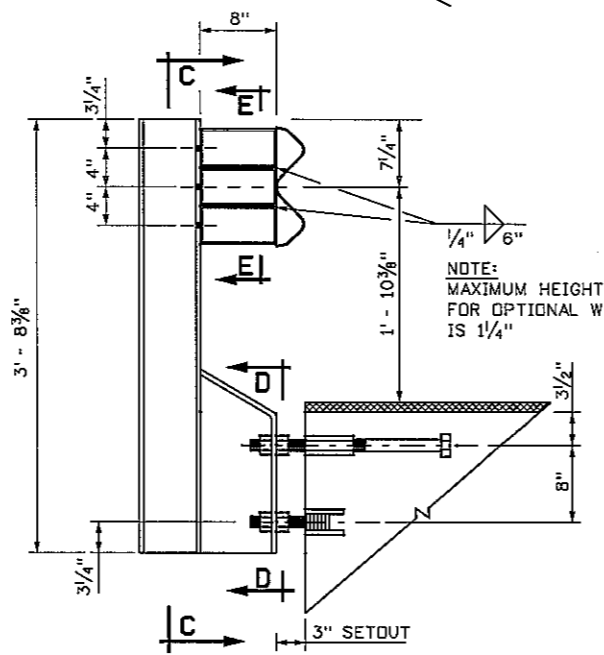
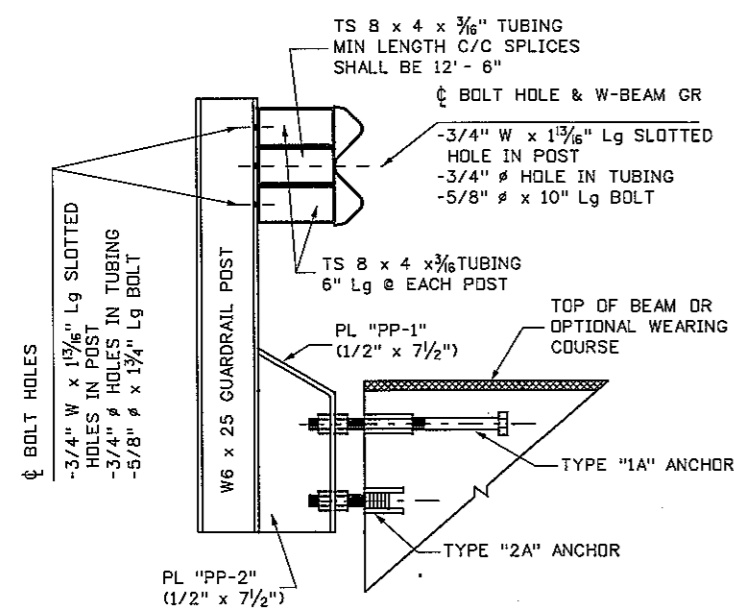

THIS SHEET SHALL BE USED IN CONJUNCTION WITH STANDARD SHEETS BR-B17A & B THRU BR-B42A & B, BR-B100, BR-B101, BR-B102A & B, AND BR-B103 AS APPLICABLE.

APPROVED: *Ernest Bailey*
DIRECTOR, ENGINEERING DIVISION DATE: 10-25-07

WEST VIRGINIA DEPARTMENT OF TRANSPORTATION
DIVISION OF HIGHWAYS
ENGINEERING DIVISION

PREPARED: 1-14-05

REVISIONS:

PRESTRESSED CONCRETE BEAM
TYPE TL-2 GUARDRAIL SYSTEM
DESIGN & ASSEMBLY DETAILS
STANDARD SHEET BR-B104

WEST VIRGINIA DEPARTMENT OF TRANSPORTATION
DIVISION OF HIGHWAYS
ENGINEERING DIVISION

2nd SMITH CREEK BRIDGE
OVER SMITH CREEK
IN PENDLETON COUNTY

DESIGNED BY: THB/
DRAWN BY: THB/
CHECKED BY: TM/
REVIEWED BY:
DATE: 12/08
SCALE:
SHEET NO 0 OF 00
BRIDGE NUMBER
10935

PRESTRESSED CONCRETE BEAM
TYPE TL-2 GUARDRAIL SYSTEM
DESIGN & ASSEMBLY DETAILS