

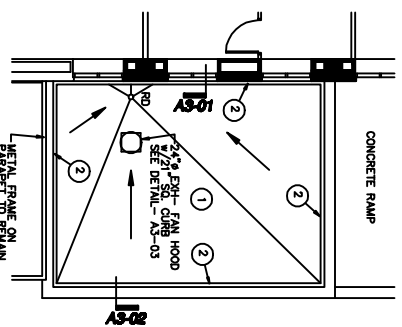

PENTHOUSE ROOF PLAN

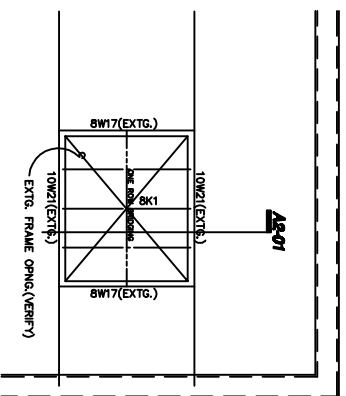

RECEIVING RM. ROOF PLAN



PARTIAL ROOF FRAMING PLAN

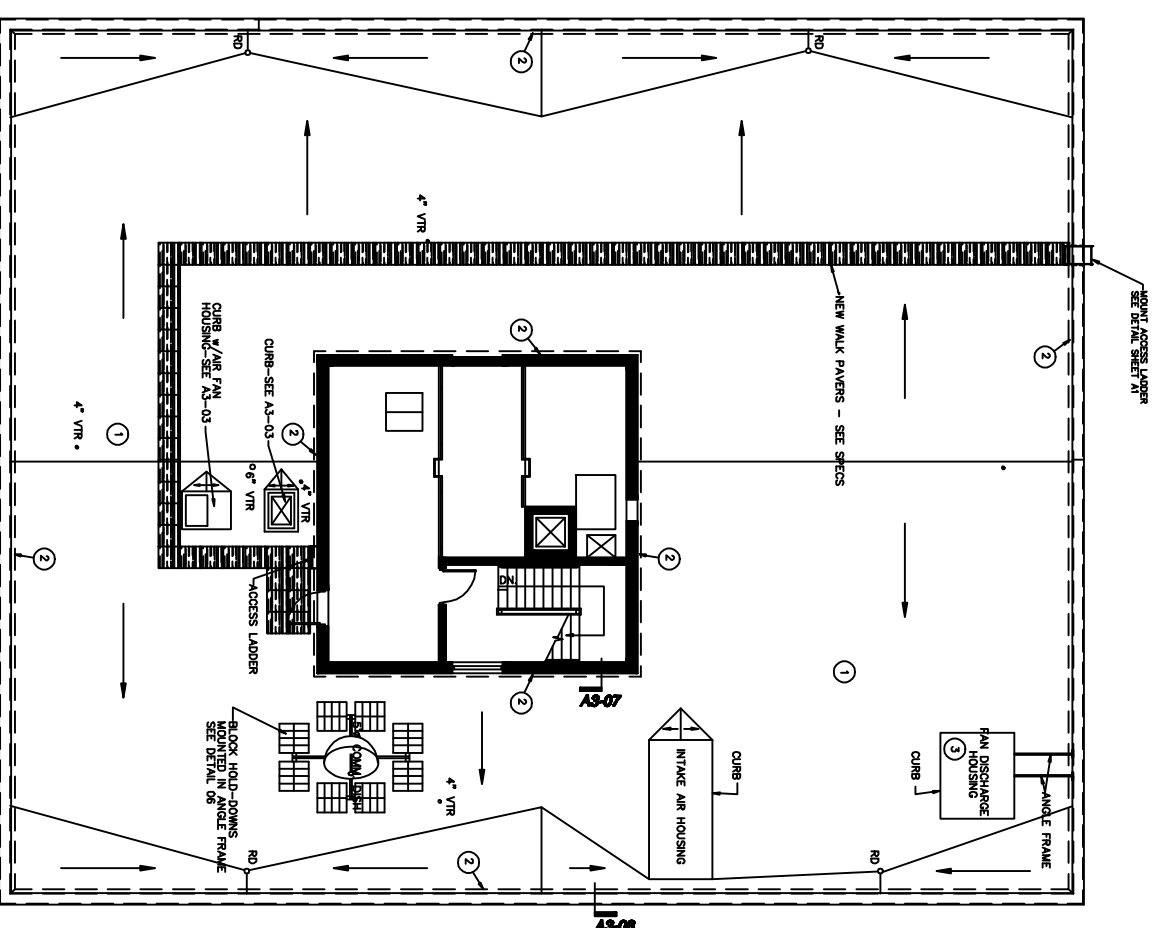

ROOF PLAN

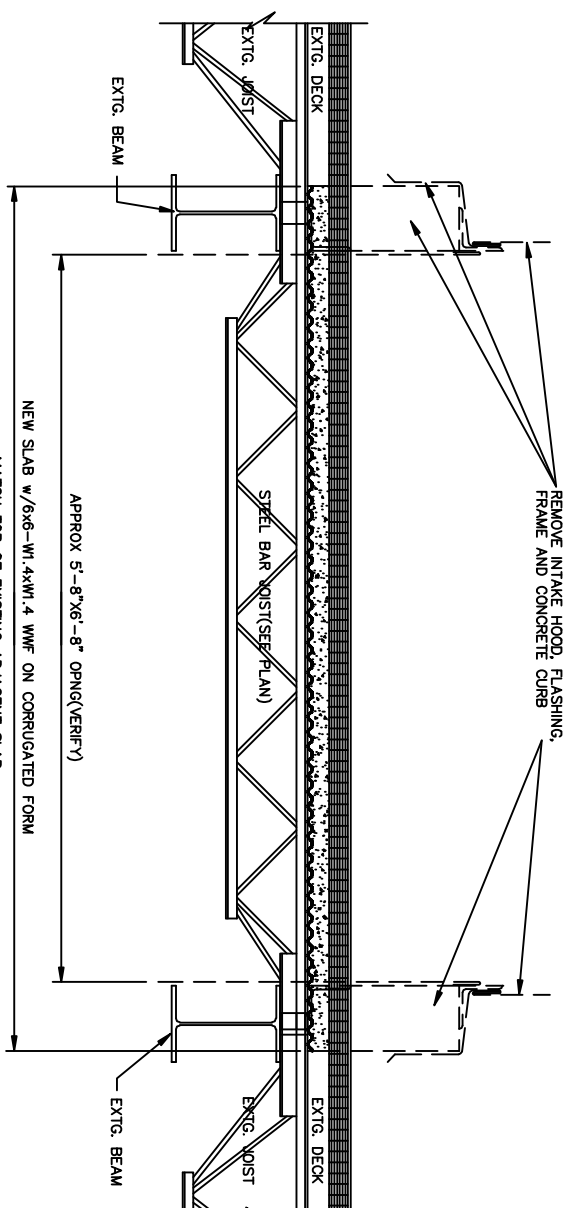

01 SECTION @ REMOVED CURB

NOTES

ALL AREAS ENCLOSED IN BORDER OF THIS PATTERN ARE TO BE DEMOLISHED. ALL ROOF FLASHING, INSULATION, AND ROOF SHEETING TO BE REMOVED. INSULATION ON EXISTING PREPARED CONCRETE DECK SURFACE: MINIMUM 1/8" PER FOOT SLOPE ON ALL AREAS TO BE DEMOLISHED.

COORDINATE +/- OWNER BEFORE DISCONNECTING ANY UTILITIES.

DIMENSIONS SHOWN OR INDICATED BY DRAWING SCALE ARE TO BE USED BY CONTRACTOR BEFORE PROCEEDING WITH ANY WORK.

DETAIL NO. 1
SHEET NO. 1
AS-02 THESE SYMBOLS REFER TO DETAILS/SECTIONS.

R.D. ROOF DRAIN - INSTALL NEW ROOF DRAIN - SEE DETAILS-04

V.T.R. VENT THROUGH ROOF - SEE DETAILS-05

SLIP-SEAL & RUBBER PAVERS(2'x2'-2-1/4") LOOSE Laid OVER DEMOLISHED ROOF WITH STRIP-ON ADHESIVE - CHARLISE SYNTEC SYSTEMS OR EQUAL.

DEMOLITION NOTES

- 1 REMOVE EXISTING BUILT-UP ROOFING, CURBS, AND INSULATION
- 2 REMOVE EXISTING GYPSUM CANTS.
- 3 REMOVE EXISTING FAN DISCHARGE HOUSING ASSOCIATED SUPPORT, AND CURB. SEE PARTIAL ROOF FRAMING PLAN THIS SHEET.

REVISION	DESCRIPTION	REVISED BY	DATE

STATE OF WEST VIRGINIA
 DEPARTMENT OF ADMINISTRATION DIVISION OF GENERAL SERVICES
 CHARLESTON, WEST VIRGINIA

LOCATION: **WEST VIRGINIA STATE CAPITOL**
 BUILDING: **BUILDING 4**
 PROJECT: **AS-BUILT**

DRAWING TITLE: **ROOF PLAN**
 DRAWN BY: **BMG** SCALE: **N/A** DATE: **5/25/09**
 DRAWING NO.: **A2**