



State of West Virginia
 Department of Administration
 Purchasing Division
 2019 Washington Street East
 Post Office Box 50130
 Charleston, WV 25305-0130

Request for Quotation

RFQ NUMBER
DNR210178

PAGE
1

ADDRESS CORRESPONDENCE TO ATTENTION OF
**KRISTA FERRELL
 304-558-2596**

RFQ COPY
 TYPE NAME/ADDRESS HERE

VENDOR

SHIP TO

DIVISION OF NATURAL RESOURCES
 CABWAYLINGO STATE FOREST
 ATTN: PARK SUPERINTENDENT
 ROUTE 1, BOX 85
 DUNLOW, WV
 25511 385-4255

DATE PRINTED 04/22/2010	TERMS OF SALE	SHIP VIA	F.O.B.	FREIGHT TERMS
BID OPENING DATE: 05/18/2010		BID OPENING TIME 01:30PM		

LINE	QUANTITY	UOP	CAT NO.	ITEM NUMBER	UNIT PRICE	AMOUNT
0001	1	LS		650-38		
PLAYGROUND EQUIPMENT FOR CABWAYLINGO REQUEST FOR QUOTATION (RFQ) THE WEST VIRGINIA STATE PURCHASING DIVISION FOR THE AGENCY, THE WEST VIRGINIA DIVISION OF NATURAL RESOURCES, IS SOLICITING BIDS TO PROVIDE THE AGENCY WITH PLAYGROUND EQUIPMENT FOR CABWAYLINGO STATE FOREST LOCATED IN DUNLOW, WEST VIRGINIA PER THE ATTACHED SPECIFICATIONS. TECHNICAL QUESTIONS CONCERNING THIS SOLICITATION MUST BE SUBMITTED IN WRITING TO KRISTA FERRELL IN THE WEST VIRGINIA STATE PURCHASING DIVISION VIA MAIL AT THE ADDRESS SHOWN IN THE BODY OF THIS RFQ, VIA FAX AT 304-558-4115, OR VIA EMAIL AT KRISTA.S.FERRELL@WV.GOV. DEADLINE FOR ALL TECHNICAL QUESTIONS IS 05/05/2010 AT THE CLOSE OF BUSINESS. ANY TECHNICAL QUESTIONS RECEIVED WILL BE ANSWERED BY FORMAL ADDENDUM ISSUED BY THE PURCHASING DIVISION AFTER THE DEADLINE HAS LAPSED. EXHIBIT 10 REQUISITION NO.: ADDENDUM ACKNOWLEDGEMENT I HEREBY ACKNOWLEDGE RECEIPT OF THE FOLLOWING CHECKED						

SEE REVERSE SIDE FOR TERMS AND CONDITIONS

SIGNATURE _____ TELEPHONE _____ DATE _____

TITLE _____ FEIN _____ ADDRESS CHANGES TO BE NOTED ABOVE

WHEN RESPONDING TO RFQ, INSERT NAME AND ADDRESS IN SPACE ABOVE LABELED 'VENDOR'

GENERAL TERMS & CONDITIONS
REQUEST FOR QUOTATION (RFQ) AND REQUEST FOR PROPOSAL (RFP)

1. Awards will be made in the best interest of the State of West Virginia.
2. The State may accept or reject in part, or in whole, any bid.
3. Prior to any award, the apparent successful vendor must be properly registered with the Purchasing Division and have paid the required \$125 fee.
4. All services performed or goods delivered under State Purchase Order/Contracts are to be continued for the term of the Purchase Order/Contracts, contingent upon funds being appropriated by the Legislature or otherwise being made available. In the event funds are not appropriated or otherwise available for these services or goods this Purchase Order/Contract becomes void and of no effect after June 30.
5. Payment may only be made after the delivery and acceptance of goods or services.
6. Interest may be paid for late payment in accordance with the *West Virginia Code*.
7. Vendor preference will be granted upon written request in accordance with the *West Virginia Code*.
8. The State of West Virginia is exempt from federal and state taxes and will not pay or reimburse such taxes.
9. The Director of Purchasing may cancel any Purchase Order/Contract upon 30 days written notice to the seller.
10. The laws of the State of West Virginia and the *Legislative Rules* of the Purchasing Division shall govern the purchasing process.
11. Any reference to automatic renewal is hereby deleted. The Contract may be renewed only upon mutual written agreement of the parties.
12. **BANKRUPTCY:** In the event the vendor/contractor files for bankruptcy protection, the State may deem this contract null and void, and terminate such contract without further order.
13. **HIPAA BUSINESS ASSOCIATE ADDENDUM:** The West Virginia State Government HIPAA Business Associate Addendum (BAA), approved by the Attorney General, is available online at www.state.wv.us/admin/purchase/vrc/hipaa.htm and is hereby made part of the agreement. Provided that the Agency meets the definition of a Cover Entity (45 CFR §160.103) and will be disclosing Protected Health Information (45 CFR §160.103) to the vendor.
14. **CONFIDENTIALITY:** The vendor agrees that he or she will not disclose to anyone, directly or indirectly, any such personally identifiable information or other confidential information gained from the agency, unless the individual who is the subject of the information consents to the disclosure in writing or the disclosure is made pursuant to the agency's policies, procedures, and rules. Vendor further agrees to comply with the Confidentiality Policies and Information Security Accountability Requirements, set forth in <http://www.state.wv.us/admin/purchase/privacy/noticeConfidentiality.pdf>.
15. **LICENSING:** Vendors must be licensed and in good standing in accordance with any and all state and local laws and requirements by any state or local agency of West Virginia, including, but not limited to, the West Virginia Secretary of State's Office, the West Virginia Tax Department, and the West Virginia Insurance Commission. The vendor must provide all necessary releases to obtain information to enable the director or spending unit to verify that the vendor is licensed and in good standing with the above entities.
16. **ANTITRUST:** In submitting a bid to any agency for the State of West Virginia, the bidder offers and agrees that if the bid is accepted the bidder will convey, sell, assign or transfer to the State of West Virginia all rights, title and interest in and to all causes of action it may now or hereafter acquire under the antitrust laws of the United States and the State of West Virginia for price fixing and/or unreasonable restraints of trade relating to the particular commodities or services purchased or acquired by the State of West Virginia. Such assignment shall be made and become effective at the time the purchasing agency tenders the initial payment to the bidder.

I certify that this bid is made without prior understanding, agreement, or connection with any corporation, firm, limited liability company, partnership, or person or entity submitting a bid for the same material, supplies, equipment or services and is in all respects fair and without collusion or Fraud. I further certify that I am authorized to sign the certification on behalf of the bidder or this bid.

INSTRUCTIONS TO BIDDERS

1. Use the quotation forms provided by the Purchasing Division. Complete all sections of the quotation form.
2. Items offered must be in compliance with the specifications. Any deviation from the specifications must be clearly indicated by the bidder. Alternates offered by the bidder as **EQUAL** to the specifications must be clearly defined. A bidder offering an alternate should attach complete specifications and literature to the bid. The Purchasing Division may waive minor deviations to specifications.
3. Unit prices shall prevail in case of discrepancy. All quotations are considered F.O.B. destination unless alternate shipping terms are clearly identified in the quotation.
4. All quotations must be delivered by the bidder to the office listed below prior to the date and time of the bid opening. Failure of the bidder to deliver the quotations on time will result in bid disqualifications: Department of Administration, Purchasing Division, 2019 Washington Street East, P.O. Box 50130, Charleston, WV 25305-0130
5. Communication during the solicitation, bid, evaluation or award periods, except through the Purchasing Division, is strictly prohibited (W.Va. C.S.R. §148-1-6.6).



State of West Virginia
 Department of Administration
 Purchasing Division
 2019 Washington Street East
 Post Office Box 50130
 Charleston, WV 25305-0130

Request for Quotation

RFQ NUMBER
DNR210178

PAGE
2

ADDRESS CORRESPONDENCE TO ATTENTION OF
**KRISTA FERRELL
 304-558-2596**

VENDOR

RFQ COPY
 TYPE NAME/ADDRESS HERE

SHIP TO

DIVISION OF NATURAL RESOURCES
 CABWAYLINGO STATE FOREST
 ATTN: PARK SUPERINTENDENT
 ROUTE 1, BOX 85
 DUNLOW, WV
 25511 385-4255

DATE PRINTED 04/22/2010	TERMS OF SALE	SHIP VIA	F.O.B.	FREIGHT TERMS
BID OPENING DATE: 05/18/2010 BID OPENING TIME 01:30PM				

LINE	QUANTITY	UOP	CAT NO.	ITEM NUMBER	UNIT PRICE	AMOUNT
<p>ADDENDUM(S) AND HAVE MADE THE NECESSARY REVISIONS TO MY PROPOSAL, PLANS AND/OR SPECIFICATION, ETC.</p> <p>ADDENDUM NO.'S:</p> <p>NO. 1</p> <p>NO. 2</p> <p>NO. 3</p> <p>NO. 4</p> <p>NO. 5</p> <p>I UNDERSTAND THAT FAILURE TO CONFIRM THE RECEIPT OF THE ADDENDUM(S) MAY BE CAUSE FOR REJECTION OF BIDS.</p> <p>VENDOR MUST CLEARLY UNDERSTAND THAT ANY VERBAL REPRESENTATION MADE OR ASSUMED TO BE MADE DURING ANY ORAL DISCUSSION HELD BETWEEN VENDOR'S REPRESENTATIVES AND ANY STATE PERSONNEL IS NOT BINDING. ONLY THE INFORMATION ISSUED IN WRITING AND ADDED TO THE SPECIFICATIONS BY AN OFFICIAL ADDENDUM IS BINDING.</p> <p>..... SIGNATURE</p> <p>..... COMPANY</p> <p>..... DATE</p>						

SEE REVERSE SIDE FOR TERMS AND CONDITIONS

SIGNATURE	TELEPHONE	DATE
TITLE	FEIN	ADDRESS CHANGES TO BE NOTED ABOVE

WHEN RESPONDING TO RFQ, INSERT NAME AND ADDRESS IN SPACE ABOVE LABELED 'VENDOR'



State of West Virginia
 Department of Administration
 Purchasing Division
 2019 Washington Street East
 Post Office Box 50130
 Charleston, WV 25305-0130

Request for Quotation

RFQ NUMBER
DNR210178

PAGE
3

ADDRESS CORRESPONDENCE TO ATTENTION OF:
**KRISTA FERRELL
 304-558-2596**

RFQ COPY
 TYPE NAME/ADDRESS HERE

VENDOR

SHIP TO

DIVISION OF NATURAL RESOURCES
 CABWAYLINGO STATE FOREST
 ATTN: PARK SUPERINTENDENT
 ROUTE 1, BOX 85
 DUNLOW, WV
 25511 385-4255

DATE PRINTED	TERMS OF SALE	SHIP VIA	F.O.B.	FREIGHT TERMS
04/22/2010				

BID OPENING DATE: **05/18/2010** BID OPENING TIME **01:30PM**

LINE	QUANTITY	UOP	CAT NO.	ITEM NUMBER	UNIT PRICE	AMOUNT
<p>NOTE: THIS ADDENDUM ACKNOWLEDGEMENT SHOULD BE SUBMITTED WITH THE BID.</p> <p>REV. 09/21/2009</p> <p>THE MODEL/BRAND/SPECIFICATIONS NAMED HEREIN ESTABLISH THE ACCEPTABLE LEVEL OF QUALITY ONLY AND ARE NOT INTENDED TO REFLECT A PREFERENCE OR FAVOR ANY PARTICULAR BRAND OR VENDOR. VENDORS WHO ARE BIDDING ALTERNATES SHOULD SO STATE AND INCLUDE PERTINENT LITERATURE AND SPECIFICATIONS. FAILURE TO PROVIDE INFORMATION FOR ANY ALTERNATES MAY BE GROUNDS FOR REJECTION OF THE BID. THE STATE RESERVES THE RIGHT TO WAIVE MINOR IRREGULARITIES IN BIDS OR SPECIFICATIONS IN ACCORDANCE WITH SECTION 148-1-4(F) OF THE WEST VIRGINIA LEGISLATIVE RULES AND REGULATIONS.</p> <p>BANKRUPTCY: IN THE EVENT THE VENDOR/CONTRACTOR FILES FOR BANKRUPTCY PROTECTION, THE STATE MAY DEEM THE CONTRACT NULL AND VOID, AND TERMINATE SUCH CONTRACT WITHOUT FURTHER ORDER.</p> <p style="text-align: center;">NOTICE</p> <p>A SIGNED BID MUST BE SUBMITTED TO:</p> <p style="text-align: center;">DEPARTMENT OF ADMINISTRATION PURCHASING DIVISION BUILDING 15 2019 WASHINGTON STREET, EAST CHARLESTON, WV 25305-0130</p> <p>THE BID SHOULD CONTAIN THIS INFORMATION ON THE FACE OF</p>						

SEE REVERSE SIDE FOR TERMS AND CONDITIONS

SIGNATURE	TELEPHONE	DATE
TITLE	FEIN	ADDRESS CHANGES TO BE NOTED ABOVE

WHEN RESPONDING TO RFQ, INSERT NAME AND ADDRESS IN SPACE ABOVE LABELED 'VENDOR'



State of West Virginia
 Department of Administration
 Purchasing Division
 2019 Washington Street East
 Post Office Box 50130
 Charleston, WV 25305-0130

Request for Quotation

RFQ NUMBER
DNR210178

PAGE
4

ADDRESS CORRESPONDENCE TO ATTENTION OF:
KRISTA FERRELL
304-558-2596

RFQ COPY
 TYPE NAME/ADDRESS HERE

VENDOR

SHIP TO

DIVISION OF NATURAL RESOURCES
CABWAYLINGO STATE FOREST
ATTN: PARK SUPERINTENDENT
ROUTE 1, BOX 85
DUNLOW, WV
25511 **385-4255**

DATE PRINTED	TERMS OF SALE	SHIP VIA	F.O.B.	FREIGHT TERMS
04/22/2010				

BID OPENING DATE: **05/18/2010** BID OPENING TIME **01:30PM**

LINE	QUANTITY	UOP	CAT NO	ITEM NUMBER	UNIT PRICE	AMOUNT
<p>THE ENVELOPE OR THE BID MAY NOT BE CONSIDERED: SEALED BID</p> <p>BUYER: KRISTA FERRELL-FILE 21 RFQ. NO.: DNR210178 BID OPENING DATE: 05/18/2010 BID OPENING TIME: 1:30 PM</p> <p>PLEASE PROVIDE A FAX NUMBER IN CASE IT IS NECESSARY TO CONTACT YOU REGARDING YOUR BID:</p> <p>-----</p> <p>CONTACT PERSON (PLEASE PRINT CLEARLY):</p> <p>-----</p> <p>***** THIS IS THE END OF RFQ DNR210178 ***** TOTAL: _____</p>						

SEE REVERSE SIDE FOR TERMS AND CONDITIONS

SIGNATURE	TELEPHONE	DATE
TITLE	FEIN	ADDRESS CHANGES TO BE NOTED ABOVE

WHEN RESPONDING TO RFQ, INSERT NAME AND ADDRESS IN SPACE ABOVE LABELED 'VENDOR'

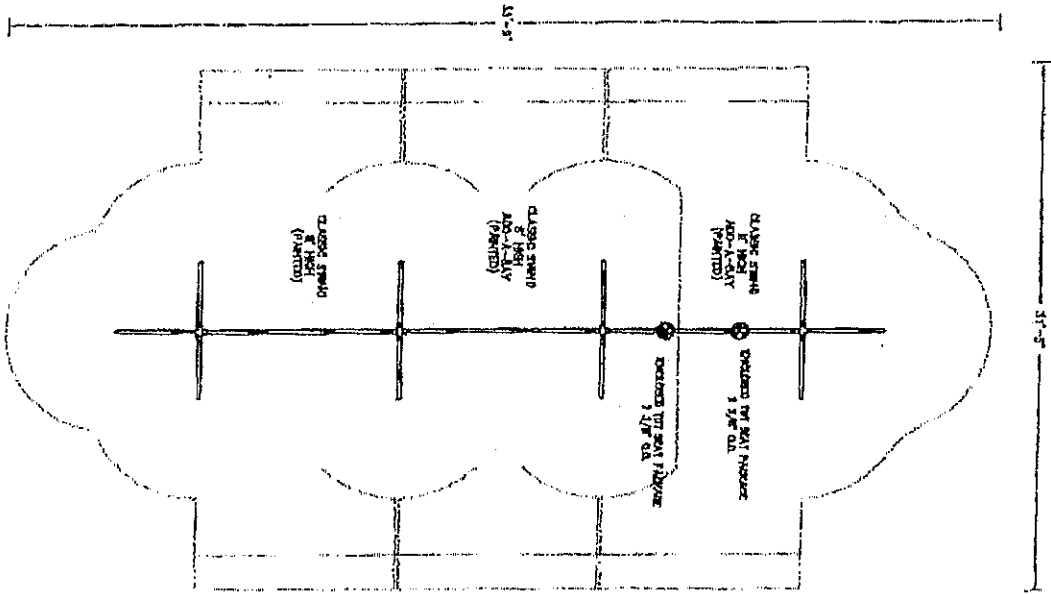

Individual
Area
Spea's

Swings

(Spruce Creek Camp Ground Area)

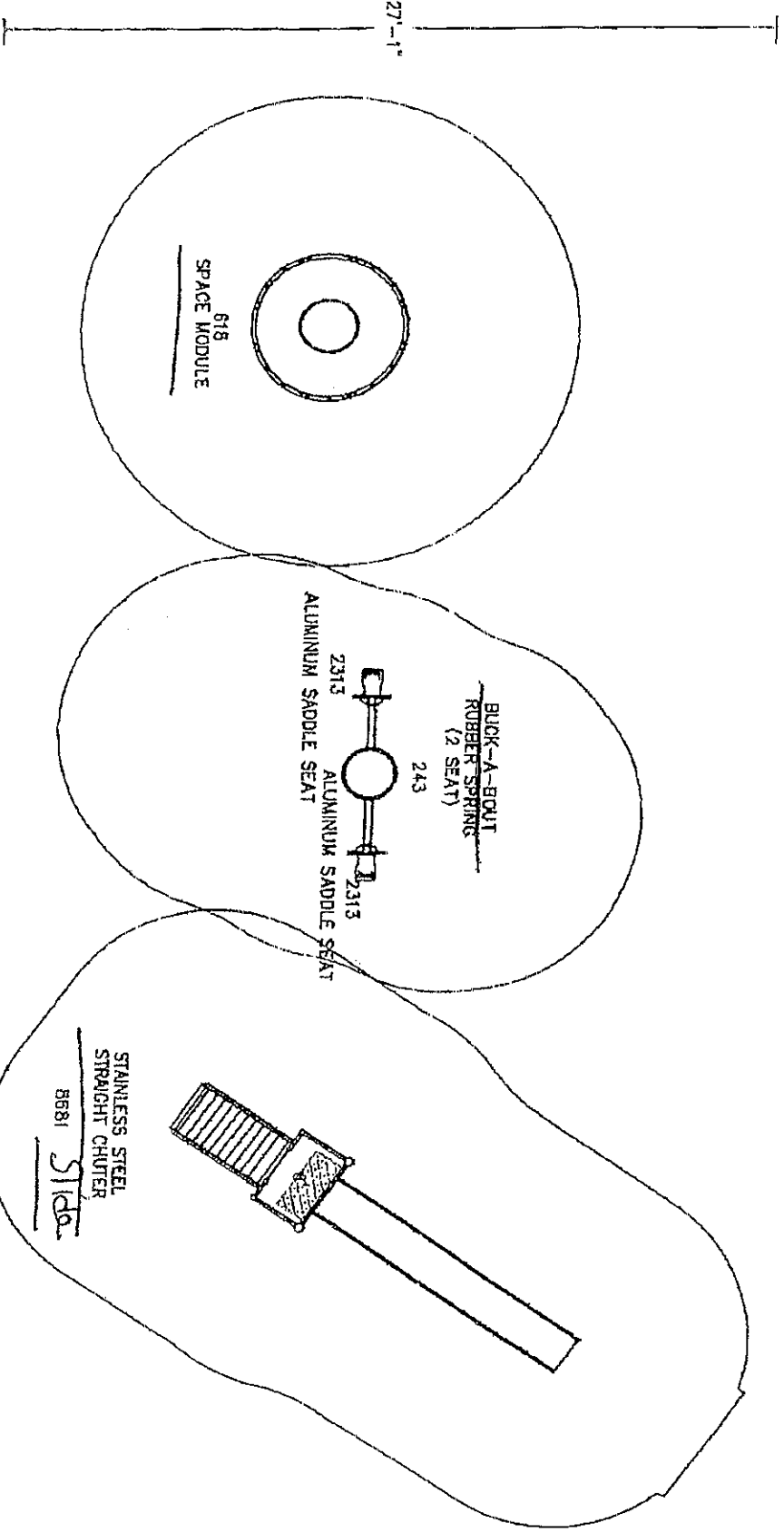
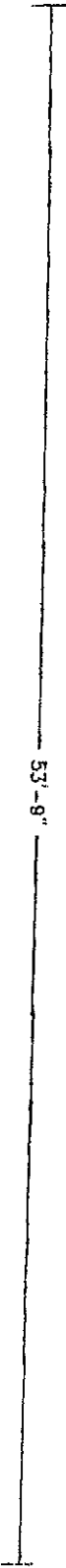

27'-1"

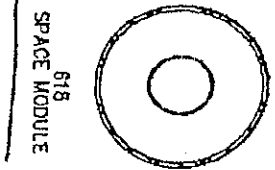
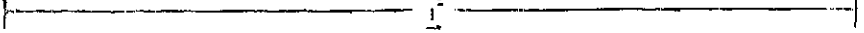

618
SPACE MODULE

BUCK-A-BOLT
RUBBER SPRING
(2 SEAT)
243



243

ALUMINUM SADDLE SEAT



2313

2313

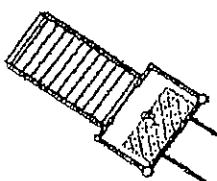

STAINLESS STEEL
STRAIGHT CHUTTER

8681
Stida

(LOWER WALNUT PICKUP AREA)

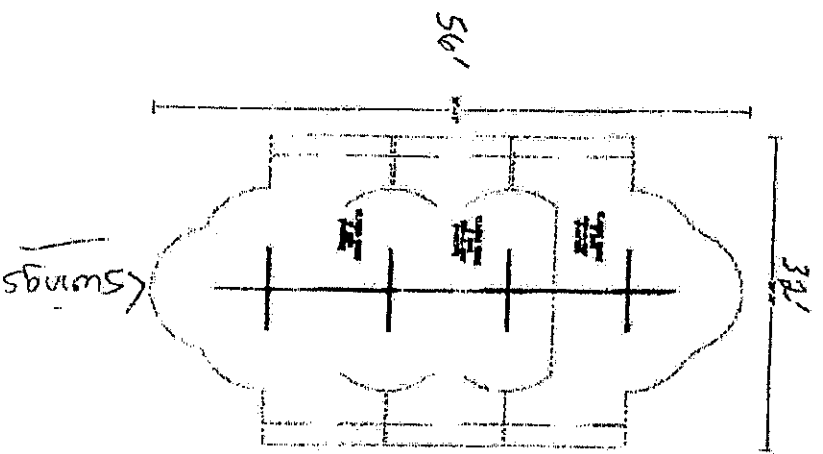
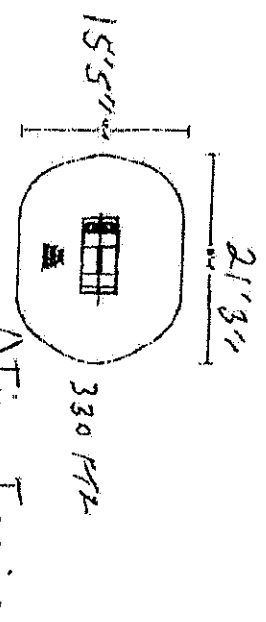
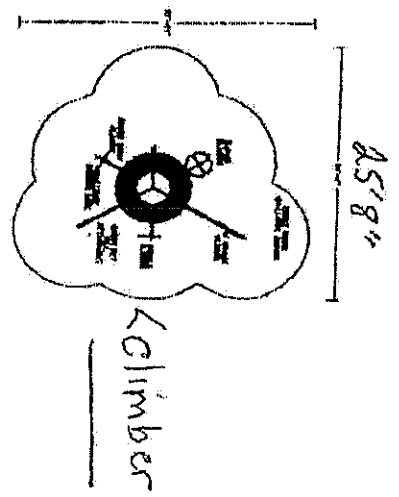
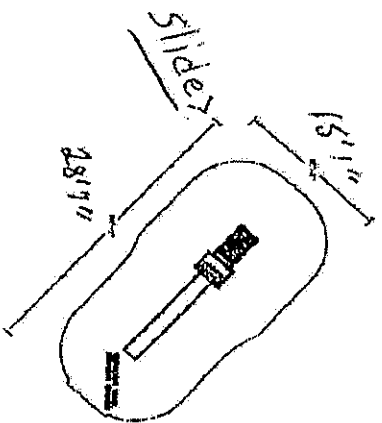

(Long Branch Picnic Area)

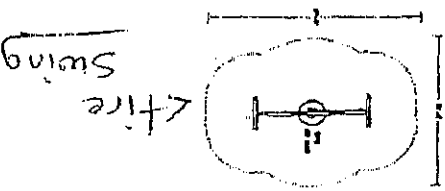
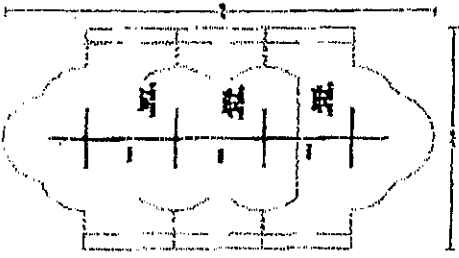
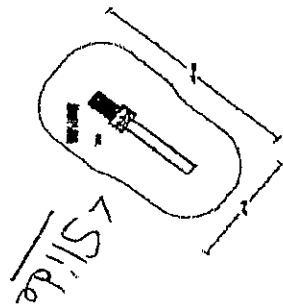
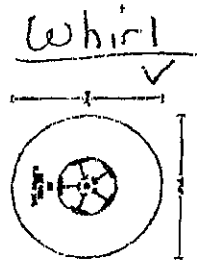

(Crum / Morgan Picnic Shelter Areas)

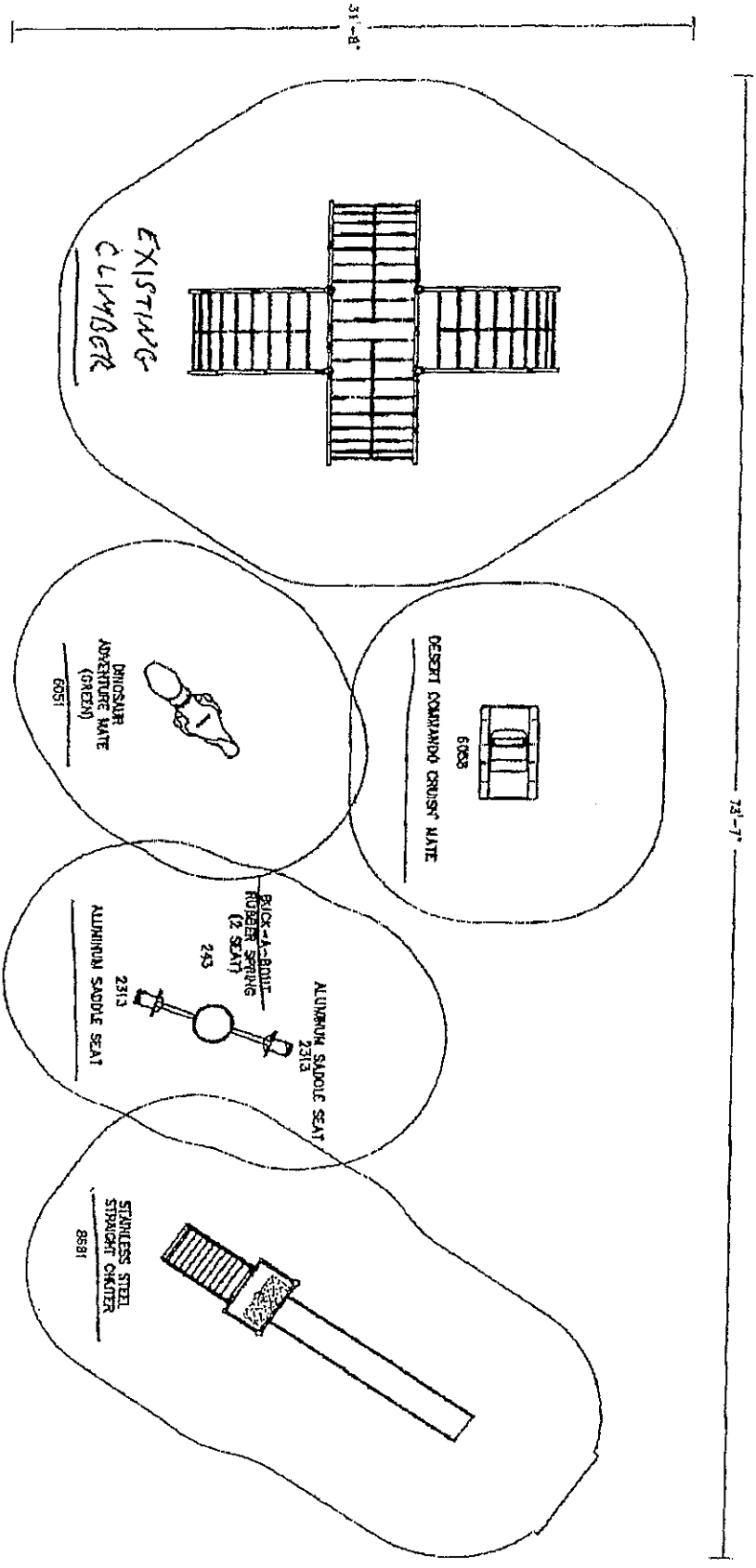

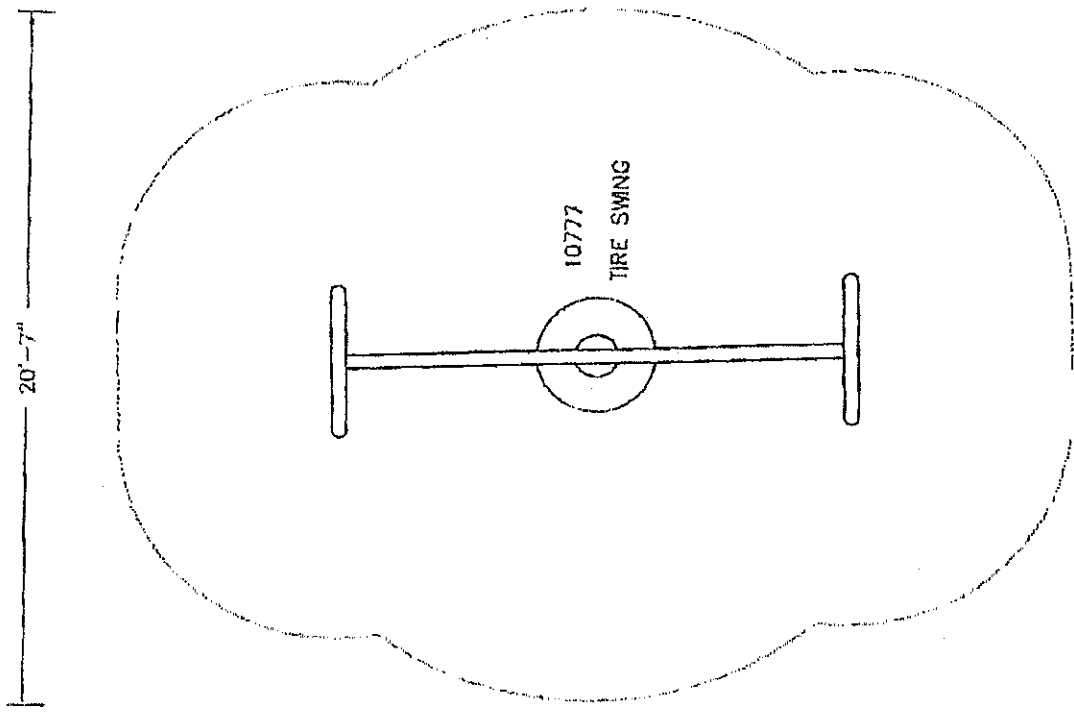

0'-22 27'-0" ← tire swing

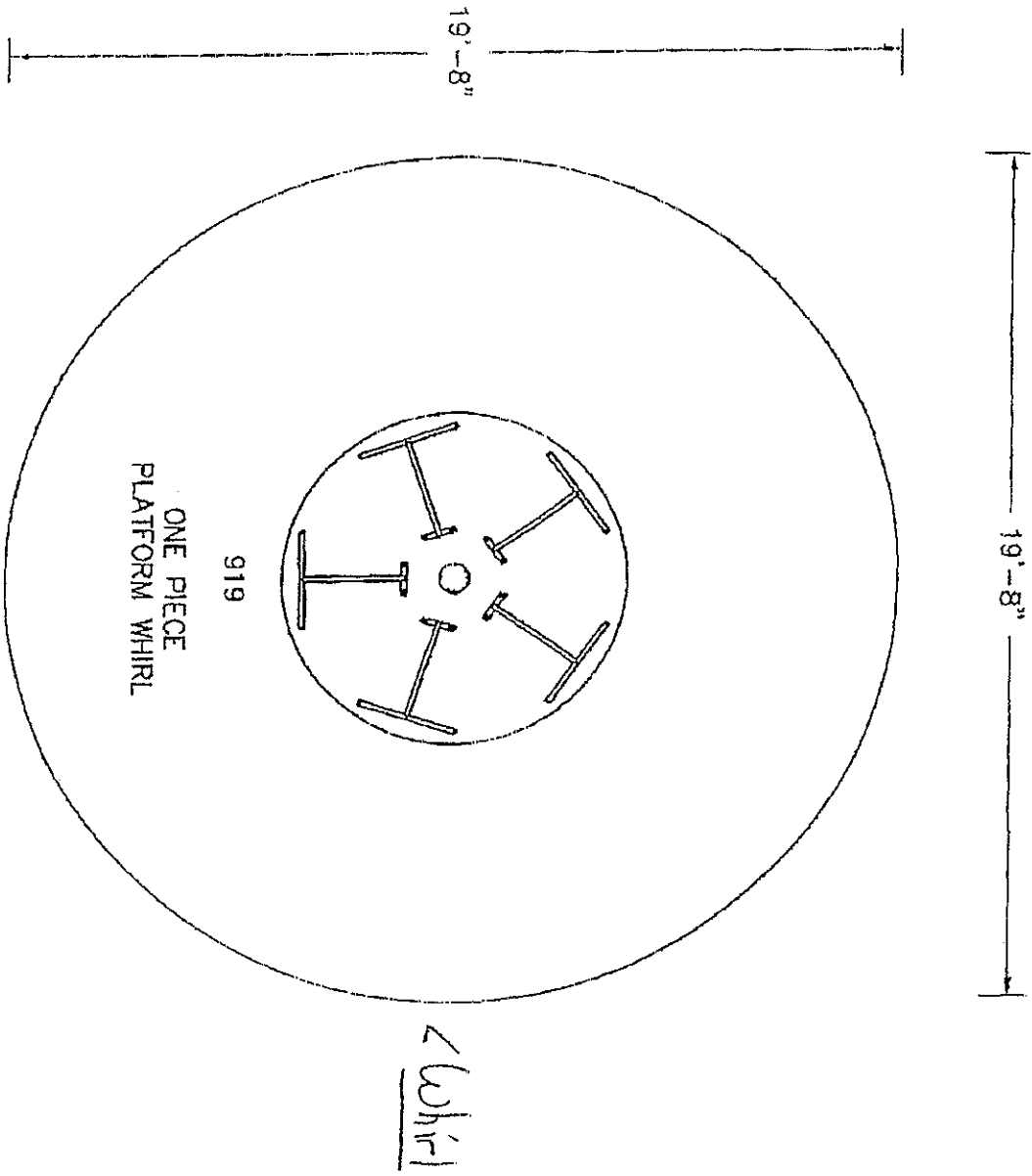

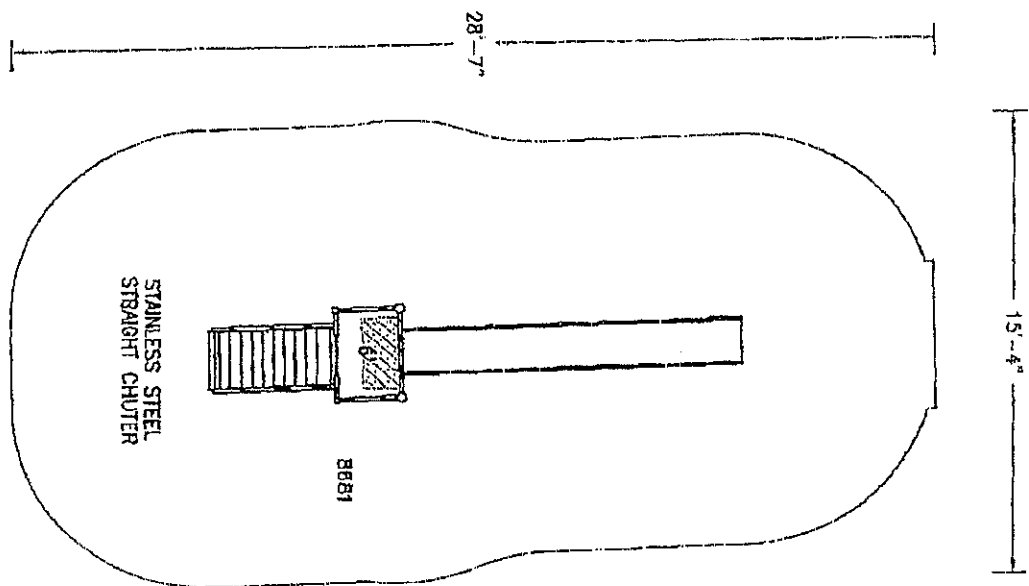

Slide

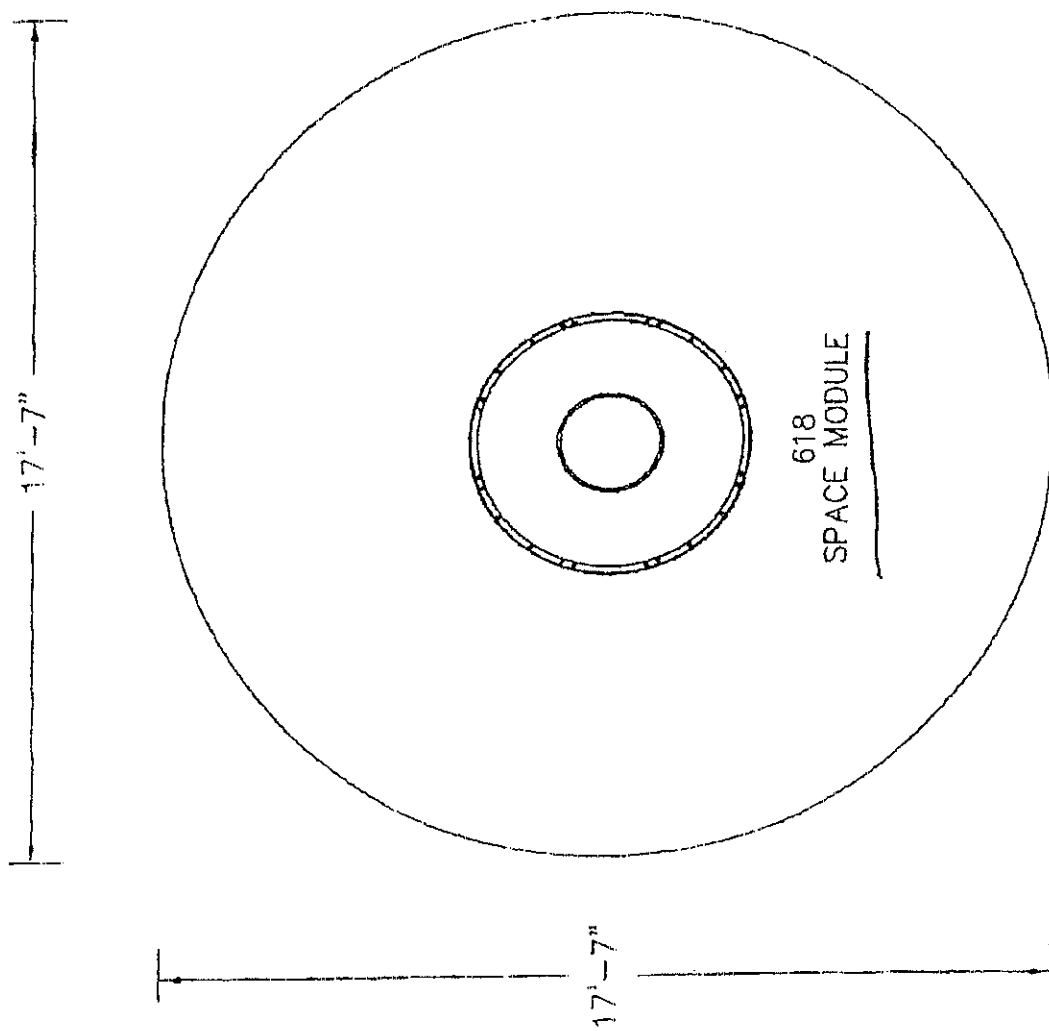

DNR210178**Cabwaylingo State Forest Playground Specifications**

To provide playground equipment at Cabwaylingo State Forest in Dunlow, West Virginia and offer play and physical activity for children ages five (5) to twelve (12). Playground equipment will be purchased for four (4) separate areas in the park. Park personnel will install all playground equipment. The award may be split if it is in the best interest of the West Virginia Division of Natural Resources. All items are to be F.O.B. Destination. Freight or delivery charges must be included in the price of the goods. Delivery must be made within sixty (60) days of purchase order award.

Long Branch Picnic Area Playground

GameTime freestanding stainless steel straight chuters slide, Item #8681, or equal. Slide must be a minimum of 6' in height; must have a top platform enclosed with metal bars; and steps to platform must have hand railings.

GameTime the whirl (Merry-Go-Round), Item #919, or equal. Equipment must have four metal u-shaped handrails on a one-piece platform with a hydraulic speed limit; and must have concealed fastener style hardware.

GameTime tire swing (one bay), Item #1077, or equal. Swing top rail must be a minimum height of 6'8"; and swing bay must be composed of galvanized steel uprights and top rail.

GameTime 8' classic swing frame, Item #P8542, or equal. Swing base must have a minimum of 2 3/8" OD top rail and legs; must be constructed of a minimum of 13 gauge galvanized pipe; and must be powder coated.

GameTime 8' classic swing frame add-a-bay, Item #P8546, or equal. Frame must have a minimum of 2 3/8" OD top rail and legs; and must be an "A" frame style.

GameTime enclosed tot seat with clevis, Item #8695, or equal. Seat must include galvanized chain and hardware for a minimum of a 2 3/8" swing frame.

Crum/Morgan Area Playground

GameTime freestanding stainless steel straight chuters slide, Item #8681, or equal. Slide must be a minimum of 6' in height; must have a top platform enclosed with metal bars; and must have steps to platform must have hand railings.

DNR210178**Cabwaylingo State Forest Playground Specifications**

GameTime buck-a-bouts, Item #243, or equal. Buck-a-bouts must have a minimum of two (2) seats with rubber springs; each seat must metal footings for both feet; and must have a U-shaped handrail (saddle seat).

GameTime saddle mates for buck-a-bout rider, Item #2313, or equal. Seats must be metal with hand holders.

GameTime cruisin mates desert commando car, Item #6058, or equal. Car must have a minimum of two (2) spring mounts; must have handholds constructed of a minimum of 1 1/6" OD galvanized pipe and a minimum of 3/16" thick flat steel; and must have a powder coat finish.

GameTime adventure mate, dinosaur rider, Item #6051, or equal. Rider must be mounted with a minimum of three (3) spring bases; and must have galvanized steel plate mounting.

GameTime in-ground mount package for the dinosaur spring mate, Item #6065, or equal.

Lower Walnut Picnic Area Playground

GameTime freestanding stainless steel straight chuters slide, Item #8681, or equal. Slide must be a minimum of 6' in height; must have a top platform enclosed with metal bars; and steps to platform must have hand railings.

GameTime PowerScape single station climber, Challenge Station, single tower, Item #8533, or equal. Station must be a minimum of 6' 4" in height; and must be composed of metal climbing stations, platform, and supports. Unit must include a cosmix climber or equal; climber must have a minimum of two openings for feet and a minimum of six openings for hands.

GameTime 8' classic swing frame, Item #P8542, or equal. Swing base must have a minimum of 2 3/8" OD top rail and legs; must be constructed of a minimum of 13 gauge galvanized pipe; and must be powder coated.

GameTime, 8' classic swing frame add-a-bay, Item #P8546, or equal. Frame must have a minimum of 2 3/8" OD top rail and legs; and must be an "A" frame style.

Game Time enclosed tot seat with clevis, Item #8695, or equal. Seat must include galvanized chain and hardware for a minimum of a 2 3/8" swing frame.

Cabwaylingo State Forest Playground Specifications

GameTime fire engine vehicle climber, Item #7002, or equal. Climber must have a deck height a minimum of 2' from ground; must be constructed of polyethylene molding; and must include steel hardware.

Spruce Creek Area Playground

GameTime freestanding stainless steel straight chuters slide, Item #8681, or equal. Slide must be a minimum of 6' in height; must have a top platform enclosed with metal bars; and must have steps to platform must have hand railings

GameTime space module climber, Item #618, or equal. Freestanding climber must have a minimum of two (2) center posts; and must include rails surrounding the inside of the top and bottom platform.

GameTime buck-a-bouts, Item #243, or equal. Buck-a-bouts must have a minimum of two (2) seats with rubber springs; each seat must metal footings for both feet; and a U-shaped handrail (saddle seat).

GameTime saddle mates for buck-a-bout rider, Item #2313, or equal. Seats must be metal with hand holders.

ITEMS FOR ALL FOUR PLAYGROUNDS

Geo-textile fabric, 2,250 sq. ft. roll, or equal. Fabric must provide a water permeable separation between the earth and the wood fiber and at least 150 gallons per square foot per minute.

Game Time, Geo-Textile Fabric, 1,125 sq. ft. roll, or equal. Fabric rolls provide a water permeable separation between the earth and the wood fiber. 150 gallons per square foot per minute.

Certified engineered wood fiber or equal. Material must be recently harvested and debarked; free of chemical treatments and additives; free of soil, twigs, leaves and other contaminates.

Cabwaylingo State Forest Playground Specifications

All playground equipment and engineered wood fiber must meet the following requirements:

- Compliance with U.S. Consumer Product Safety Commission, Handbook for Public Playground Safety.
- Compliance with ASTM Standard F 1487.
- Compliance with Architectural and Transportation Barriers Compliance Board, Americans with Disabilities Act (ADA) Accessibility Guidelines for Buildings and Facilities; Play Areas.

Vendors must submit the following attachments:

- Complete manufacturer's parts specifications and warranties.
- Layout drawing to scale of the proposed play structure or equipment.
- ASTM and CPSC Statement of Compliance

Warranties:

- All equipment and engineered wood fiber must be guaranteed to be free of defects in workmanship and material for a minimum of one year from date of acceptance. However, if manufacturer warranty periods are longer than the required minimum one year warranty, those warranties shall apply.

Color scheme of equipment must be coordinated with Cabwaylingo State Forest. Color of items will be selected from manufacturer's standard colors.

Please contact park headquarters at 304-385-4255 to schedule a site walk through if necessary. The site walk through is not mandatory.

**Cabwaylingo State Forrest
PLAYGROUND EQUIPMENT SHEET**

Please complete the below information concerning the brand(s) of equipment being bid in relation to this project. If bidding "or equal" brands, please attach manufacturer's literature documenting that it meets the mandatory requirements stated in the specifications. Vendors should note the areas of the provided manufacturer's literature that adheres to the mandatory requirements outlined in the Request For Quotation.

Item No.	Equipment	Manufacturer	Item
1	Long Branch Picnic Area Playground Game Time freestanding stainless steel straight chuters slide, Item #8681, or equal.		
2	Long Branch Picnic Area Playground Game Time the whirl (Merry-Go-Round), Item #919, or equal.		
3	Long Branch Picnic Area Playground Game Time tire swing (one bay), Item #10777, or equal.		
4	Long Branch Picnic Area Playground GameTime 8' classic swing frame, Item #P8542, or equal.		
5	Long Branch Picnic Area Playground GameTime, 8' classic swing frame add-a-bay, Item #P8546, or equal.		
6	Long Branch Picnic Area Playground Game Time enclosed tot seat with clevis, Item #8695, or equal.		
7	Crum/ Morgan Area Playground Game Time freestanding stainless steel straight chuters slide, Item #8681, or equal.		
8	Crum/ Morgan Area Playground GameTime buck-a-bouts, Item #243, or equal.		
9	Crum/ Morgan Area Playground GameTime saddle mates for buck-a-bout rider, Item #2313, or equal.		

**Cabwaylingo State Forrest
PLAYGROUND EQUIPMENT SHEET**

Item No.	Equipment	Manufacturer	Item
10	Crum/ Morgan Area Playground GameTime cruisin mates desert commando car, Item #6058, or equal.		
11	Crum/ Morgan Area Playground GameTime adventure mate, dinosaur rider, Item #6051, or equal.		
12	Crum/ Morgan Area Playground GameTime in-ground mount package for the dinosaur spring mate, Item #6065, or equal.		
13	Lower Walnut Picnic Area Playground GameTime freestanding stainless steel straight chuters slide, Item #8681, or equal.		
14	Lower Walnut Picnic Area Playground GameTime, PowerScape single station climber, Challenge Station, single tower, Item #8533, or equal.		
15	Lower Walnut Picnic Area Playground GameTime 8' classic swing frame, Item #P8542, or equal.		
16	Lower Walnut Picnic Area Playground GameTime, 8' classic swing frame add-a- bay, Item #P8546, or equal.		
17	Lower Walnut Picnic Area Playground GameTime enclosed tot seat with clevis, Item #8695, or equal.		
18	Lower Walnut Picnic Area Playground GameTime, Fire Engine Vehicle Climber, Item No. 7002 or Equal.		
19	Spruce Creek Area Playground GameTime freestanding stainless steel straight chuters slide, Item #8681, or equal.		

Cabwaylingo State Forrest
PLAYGROUND EQUIPMENT SHEET

Item No.	Equipment	Manufacturer	Item
20	Spruce Creek Area Playground GameTime space module climber, Item #618, or equal.		
21	Spruce Creek Area Playground GameTime buck-a-bouts, Item #243, or equal.		
22	Spruce Creek Area Playground GameTime saddle mates for buck-a-bout rider, Item #2313, r equal.		
23	Items For All Four Playgrounds Geo-textile fabric, 2,250 sq. ft. roll, or equal.		
24	Items For All Four Playgrounds Geo-textile fabric, 1,125 sq. ft. roll, or equal.		
25	Items For All Four Playgrounds Certified engineered wood fiber or equal.		

Cabwaylingo State Forest Playground Equipment

PRICING SHEET

Item No.	Quantity	Description	Unit Price	Amount
1	1	Long Branch Picnic Area Playground Game Time freestanding stainless steel straight chuters slide, Item #8681, or equal.		
2	1	Long Branch Picnic Area Playground Game Time the whirl (Merry-Go- Round), Item #919, or equal.		
3	1	Long Branch Picnic Area Playground Game Time tire swing (one bay), Item #10777, or equal.		
4	1	Long Branch Picnic Area Playground GameTime 8' classic swing frame, Item #P8542, or equal.		
5	1	Long Branch Picnic Area Playground GameTime, 8' classic swing frame add- a-bay, Item #P8546, or equal.		
6	2	Long Branch Picnic Area Playground Game Time enclosed tot seat with clevis, Item #8695, or equal.		
7	1	Crum/ Morgan Area Playground Game Time freestanding stainless steel straight chuters slide, Item #8681, or equal.		
8	1	Crum/ Morgan Area Playground GameTime buck-a-bouts, Item #243, or equal.		
9	2	Crum/ Morgan Area Playground GameTime saddle mates for buck-a- bout rider, Item #2313, r equal.		
10	1	Crum/ Morgan Area Playground GameTime cruisin mates desert commando car, Item #6058, or equal.		
11	1	Crum/ Morgan Area Playground GameTime adventure mate, dinosaur rider, Item #6051, or equal.		

Cabwaylingo State Forest Playground Equipment

PRICING SHEET

Item No.	Quantity	Description	Unit Price	Amount
12		Crum/ Morgan Area Playground GameTime in-ground mount package for the dinosaur spring mate, Item #6065, or equal.		
13	1	Lower Walnut Picnic Area Playground GameTime freestanding stainless steel straight chuters slide, Item #8681, or equal.		
14	1	Lower Walnut Picnic Area Playground GameTime, PowerScape single station climber, Challenge Station, single tower, Item #8533, or equal.		
15	1	Lower Walnut Picnic Area Playground GameTime 8' classic swing frame, Item #P8542, or equal.		
16	1	Lower Walnut Picnic Area Playground GameTime, 8' classic swing frame add- a-bay, Item #P8546, or equal.		
17	2	Lower Walnut Picnic Area Playground GameTime enclosed tot seat with clevis, Item #8695, or equal.		
18	1	Lower Walnut Picnic Area Playground GameTime, Fire Engine Vehicle Climber, Item #7002, or equal.		
19	1	Spruce Creek Area Playground GameTime freestanding stainless steel straight chuters slide, Item #8681, or equal.		
20	1	Spruce Creek Area Playground GameTime space module climber, Item #618, or equal.		
21	1	Spruce Creek Area Playground GameTime buck-a-bouts, Item #243, or equal.		
22	2	Spruce Creek Area Playground GameTime saddle mates for buck-a- bout rider, Item #2313, r equal.		

Cabwaylingo State Forest Playground Equipment

PRICING SHEET

Item No.	Quantity	Description	Unit Price	Amount
23	4	Items For All Four Playgrounds Geo-textile fabric, 2,250 sq. ft. roll, or equal.		
24	1	Items For All Four Playgrounds Geo-textile fabric, 1,125 sq. ft. roll, or equal.		
25	9,811 sq. ft.	Items For All Four Playgrounds Certified engineered wood fiber or equal.		
		TOTAL		

State of West Virginia

VENDOR PREFERENCE CERTIFICATE

Certification and application* is hereby made for Preference in accordance with West Virginia Code, §5A-3-37. (Does not apply to construction contracts) West Virginia Code, §5A-3-37, provides an opportunity for qualifying vendors to request (at the time of bid) preference for their residency status. Such preference is an evaluation method only and will be applied only to the cost bid in accordance with the West Virginia Code. This certificate for application is to be used to request such preference. The Purchasing Division will make the determination of the Resident Vendor Preference, if applicable.

- 1. Application is made for 2.5% resident vendor preference for the reason checked: Bidder is an individual resident vendor and has resided continuously in West Virginia for four (4) years immediately preceding the date of this certification; or, Bidder is a partnership, association or corporation resident vendor and has maintained its headquarters or principal place of business continuously in West Virginia for four (4) years immediately preceding the date of this certification; or 80% of the ownership interest of Bidder is held by another individual, partnership, association or corporation resident vendor who has maintained its headquarters or principal place of business continuously in West Virginia for four (4) years immediately preceding the date of this certification; or, Bidder is a nonresident vendor which has an affiliate or subsidiary which employs a minimum of one hundred state residents and which has maintained its headquarters or principal place of business within West Virginia continuously for the four (4) years immediately preceding the date of this certification; or,
2. Application is made for 2.5% resident vendor preference for the reason checked: Bidder is a resident vendor who certifies that, during the life of the contract, on average at least 75% of the employees working on the project being bid are residents of West Virginia who have resided in the state continuously for the two years immediately preceding submission of this bid; or,
3. Application is made for 2.5% resident vendor preference for the reason checked: Bidder is a nonresident vendor employing a minimum of one hundred state residents or is a nonresident vendor with an affiliate or subsidiary which maintains its headquarters or principal place of business within West Virginia employing a minimum of one hundred state residents who certifies that, during the life of the contract, on average at least 75% of the employees or Bidder's affiliate's or subsidiary's employees are residents of West Virginia who have resided in the state continuously for the two years immediately preceding submission of this bid; or,
4. Application is made for 5% resident vendor preference for the reason checked: Bidder meets either the requirement of both subdivisions (1) and (2) or subdivision (1) and (3) as stated above; or,
5. Application is made for 3.5% resident vendor preference who is a veteran for the reason checked: Bidder is an individual resident vendor who is a veteran of the United States armed forces, the reserves or the National Guard and has resided in West Virginia continuously for the four years immediately preceding the date on which the bid is submitted; or,
6. Application is made for 3.5% resident vendor preference who is a veteran for the reason checked: Bidder is a resident vendor who is a veteran of the United States armed forces, the reserves or the National Guard, if, for purposes of producing or distributing the commodities or completing the project which is the subject of the vendor's bid and continuously over the entire term of the project, on average at least seventy-five percent of the vendor's employees are residents of West Virginia who have resided in the state continuously for the two immediately preceding years

Bidder understands if the Secretary of Revenue determines that a Bidder receiving preference has failed to continue to meet the requirements for such preference, the Secretary may order the Director of Purchasing to: (a) reject the bid; or (b) assess a penalty against such Bidder in an amount not to exceed 5% of the bid amount and that such penalty will be paid to the contracting agency or deducted from any unpaid balance on the contract or purchase order

By submission of this certificate, Bidder agrees to disclose any reasonably requested information to the Purchasing Division and authorizes the Department of Revenue to disclose to the Director of Purchasing appropriate information verifying that Bidder has paid the required business taxes, provided that such information does not contain the amounts of taxes paid nor any other information deemed by the Tax Commissioner to be confidential

Under penalty of law for false swearing (West Virginia Code, §61-5-3), Bidder hereby certifies that this certificate is true and accurate in all respects; and that if a contract is issued to Bidder and if anything contained within this certificate changes during the term of the contract, Bidder will notify the Purchasing Division in writing immediately.

Bidder: _____ Signed: _____

Date: _____ Title: _____

*Check any combination of preference consideration(s) indicated above which you are entitled to receive

RFQ No _____

STATE OF WEST VIRGINIA
Purchasing Division

PURCHASING AFFIDAVIT

West Virginia Code §5A-3-10a states: No contract or renewal of any contract may be awarded by the state or any of its political subdivisions to any vendor or prospective vendor when the vendor or prospective vendor or a related party to the vendor or prospective vendor is a debtor and the debt owed is an amount greater than one thousand dollars in the aggregate

DEFINITIONS:

"Debt" means any assessment, premium, penalty, fine, tax or other amount of money owed to the state or any of its political subdivisions because of a judgment, fine, permit violation, license assessment, defaulted workers' compensation premium, penalty or other assessment presently delinquent or due and required to be paid to the state or any of its political subdivisions, including any interest or additional penalties accrued thereon

"Debtor" means any individual, corporation, partnership, association, limited liability company or any other form or business association owing a debt to the state or any of its political subdivisions. "Political subdivision" means any county commission; municipality; county board of education; any instrumentality established by a county or municipality; any separate corporation or instrumentality established by one or more counties or municipalities, as permitted by law; or any public body charged by law with the performance of a government function or whose jurisdiction is coextensive with one or more counties or municipalities. "Related party" means a party, whether an individual, corporation, partnership, association, limited liability company or any other form or business association or other entity whatsoever, related to any vendor by blood, marriage, ownership or contract through which the party has a relationship of ownership or other interest with the vendor so that the party will actually or by effect receive or control a portion of the benefit, profit or other consideration from performance of a vendor contract with the party receiving an amount that meets or exceed five percent of the total contract amount

EXCEPTION: The prohibition of this section does not apply where a vendor has contested any tax administered pursuant to chapter eleven of this code, workers' compensation premium, permit fee or environmental fee or assessment and the matter has not become final or where the vendor has entered into a payment plan or agreement and the vendor is not in default of any of the provisions of such plan or agreement.

Under penalty of law for false swearing (*West Virginia Code §61-5-3*), it is hereby certified that the vendor affirms and acknowledges the information in this affidavit and is in compliance with the requirements as stated

WITNESS THE FOLLOWING SIGNATURE

Vendor's Name: _____

Authorized Signature: _____ Date: _____

State of _____

County of _____, to-wit:

Taken, subscribed, and sworn to before me this ____ day of _____, 20__.

My Commission expires _____, 20__.

AFFIX SEAL HERE

NOTARY PUBLIC _____