



State of West Virginia
 Department of Administration
 Purchasing Division
 2019 Washington Street East
 Post Office Box 50130
 Charleston, WV 25305-0130

Request for Quotation

RFQ NUMBER
 DNR209199

PAGE
 1

ADDRESS CORRESPONDENCE TO ATTENTION OF:
 KRISTA FERRELL
 804-558-2596

VENDOR

RFQ COPY
 TYPE NAME/ADDRESS HERE

SHIP TO

DIVISION OF NATURAL RESOURCES
 BABCOCK STATE PARK
 ATTN: PARK SUPERINTENDENT
 HC 35, BOX 150
 CLIFFTOP, WV
 25831 438-5662

DATE PRINTED	TERMS OF SALE	SHIP VIA	F.O.B.	FREIGHT TERMS
07/30/2009				

BID OPENING DATE: 09/01/2009 BID OPENING TIME 01:30PM

LINE	QUANTITY	UOP	CAT NO	ITEM NUMBER	UNIT PRICE	AMOUNT
0001	1	LS		650-38		
PLAYGROUND EQUIPMENT FOR BABCOCK STATE PARK REQUEST FOR QUOTATION (RFQ) THE WEST VIRGINIA STATE PURCHASING DIVISION FOR THE AGENCY, THE WEST VIRGINIA DIVISION OF NATURAL RESOURCES, IS SOLICITING BIDS TO PROVIDE THE AGENCY WITH PLAYGROUND EQUIPMENT FOR BABCOCK STATE PARK LOCATED IN CLIFFTOP, WEST VIRGINIA PER THE ATTACHED SPECIFICATIONS. NO INSTALLATION IS REQUIRED. A MANDATORY PRE-BID WILL BE HELD ON AUGUST 10, 2009 AT 1:30 PM AT THE PARK'S HEADQUARTERS IN CLIFFTOP, WV. ALL INTERESTED PARTIES ARE REQUIRED TO ATTEND THIS MEETING FAILURE TO ATTEND THE MANDATORY PRE-BID SHALL RESULT IN DISQUALIFICATION OF THE BID. NO ONE PERSON MAY REPRESENT MORE THAN ONE BIDDER. AN ATTENDANCE SHEET WILL BE MADE AVAILABLE FOR ALL POTENTIAL BIDDERS TO COMPLETE. THIS WILL SERVE AS THE OFFICIAL DOCUMENT VERIFYING ATTENDANCE AT THE MANDATORY PRE-BID. FAILURE TO PROVIDE YOUR COMPANY AND REPRESENTATIVE NAME ON THE ATTENDANCE SHEET WILL RESULT IN DISQUALIFICATION OF THE BID. THE STATE WILL NOT ACCEPT ANY OTHER DOCUMENTATION TO VERIFY ATTENDANCE. THE BIDDER IS RESPONSIBLE FOR ENSURING THEY HAVE						

SEE REVERSE SIDE FOR TERMS AND CONDITIONS

SIGNATURE _____ TELEPHONE _____ DATE _____

TITLE _____ FEIN _____ ADDRESS CHANGES TO BE NOTED ABOVE

WHEN RESPONDING TO RFQ, INSERT NAME AND ADDRESS IN SPACE ABOVE LABELED 'VENDOR'

**GENERAL TERMS & CONDITIONS
REQUEST FOR QUOTATION (RFQ) AND REQUEST FOR PROPOSAL (RFP)**

1. Awards will be made in the best interest of the State of West Virginia
2. The State may accept or reject in part, or in whole, any bid
3. All quotations are governed by the *West Virginia Code* and the *Legislative Rules* of the Purchasing Division
4. Prior to any award, the apparent successful vendor must be properly registered with the Purchasing Division and have paid the required \$125 fee.
5. All services performed or goods delivered under State Purchase Order/Contracts are to be continued for the term of the Purchase Order/Contracts, contingent upon funds being appropriated by the Legislature or otherwise being made available. In the event funds are not appropriated or otherwise available for these services or goods, this Purchase Order/Contract becomes void and of no effect after June 30.
6. Payment may only be made after the delivery and acceptance of goods or services.
7. Interest may be paid for late payment in accordance with the *West Virginia Code*.
8. Vendor preference will be granted upon written request in accordance with the *West Virginia Code*
9. The State of West Virginia is exempt from federal and state taxes and will not pay or reimburse such taxes.
10. The Director of Purchasing may cancel any Purchase Order/Contract upon 30 days written notice to the seller
11. The laws of the State of West Virginia and the *Legislative Rules* of the Purchasing Division shall govern all rights and duties under the Contract, including without limitation the validity of this Purchase Order/Contract.
12. Any reference to automatic renewal is hereby deleted. The Contract may be renewed only upon mutual written agreement of the parties.
13. **BANKRUPTCY:** In the event the vendor/contractor files for bankruptcy protection, the State may deem this contract null and void, and terminate such contract without further order.
14. **HIPAA BUSINESS ASSOCIATE ADDENDUM:** The West Virginia State Government HIPAA Business Associate Addendum (BAA), approved by the Attorney General, and available online at the Purchasing Division's web site (<http://www.state.wv.us/admin/purchase/vrc/hipaa.htm>) is hereby made part of the agreement. Provided that, the Agency meets the definition of a Cover Entity (45 CFR §160.103) and will be disclosing Protected Health Information (45 CFR §160.103) to the vendor.
15. **WEST VIRGINIA ALCOHOL & DRUG-FREE WORKPLACE ACT:** If this Contract constitutes a public improvement construction contract as set forth in Article 1D, Chapter 21 of the West Virginia Code ("The West Virginia Alcohol and Drug-Free Workplace Act"), then the following language shall hereby become part of this Contract: "The contractor and its subcontractors shall implement and maintain a written drug-free workplace policy in compliance with the West Virginia Alcohol and Drug-Free Workplace Act, as set forth in Article 1D, Chapter 21 of the West Virginia Code. The contractor and its subcontractors shall provide a sworn statement in writing, under the penalties of perjury, that they maintain a valid drug-free work place policy in compliance with the West Virginia and Drug-Free Workplace Act. It is understood and agreed that this Contract shall be cancelled by the awarding authority if the Contractor: 1) Fails to implement its drug-free workplace policy; 2) Fails to provide information regarding implementation of the contractor's drug-free workplace policy at the request of the public authority; or 3) Provides to the public authority false information regarding the contractor's drug-free workplace policy."

INSTRUCTIONS TO BIDDERS

1. Use the quotation forms provided by the Purchasing Division.
2. **SPECIFICATIONS:** Items offered must be in compliance with the specifications. Any deviation from the specifications must be clearly indicated by the bidder. Alternates offered by the bidder as **EQUAL** to the specifications must be clearly defined. A bidder offering an alternate should attach complete specifications and literature to the bid. The Purchasing Division may waive minor deviations to specifications.
3. Complete all sections of the quotation form
4. Unit prices shall prevail in case of discrepancy.
5. All quotations are considered F O B destination unless alternate shipping terms are clearly identified in the quotation.
6. **BID SUBMISSION:** All quotations must be delivered by the bidder to the office listed below prior to the date and time of the bid opening. Failure of the bidder to deliver the quotations on time will result in bid disqualifications: Department of Administration, Purchasing Division, 2019 Washington Street East, P.O. Box 50130, Charleston, WV 25305-0130



State of West Virginia
 Department of Administration
 Purchasing Division
 2019 Washington Street East
 Post Office Box 50130
 Charleston, WV 25305-0130

Request for Quotation

RFQ NUMBER
 DNR209199

PAGE
 2

ADDRESS CORRESPONDENCE TO ATTENTION OF
 KRISTA FERRELL
 304-558-2596

VENDOR

RFQ COPY
 TYPE NAME/ADDRESS HERE

SHIP TO

DIVISION OF NATURAL RESOURCES
 BABCOCK STATE PARK
 ATTN: PARK SUPERINTENDENT
 HC 35, BOX 150
 CLIFFTOP, WV
 25831 438-5662

DATE PRINTED	TERMS OF SALE	SHIP VIA	F.O.B.	FREIGHT TERMS
07/30/2009				

BID OPENING DATE: 09/01/2009 BID OPENING TIME 01:30PM

LINE	QUANTITY	UOP	CAT NO.	ITEM NUMBER	UNIT PRICE	AMOUNT
<p>COMPLETED THE INFORMATION REQUIRED ON THE ATTENDANCE SHEET. THE PURCHASING DIVISION AND THE STATE AGENCY WILL NOT ASSUME ANY RESPONSIBILITY FOR A BIDDER-S FAILURE TO COMPLETE THE PRE-BID ATTENDANCE SHEET. IN ADDITION, WE REQUEST THAT ALL POTENTIAL BIDDERS INCLUDE THEIR E-MAIL ADDRESS AND FAX NUMBER.</p> <p>ALL POTENTIAL BIDDERS ARE REQUESTED TO ARRIVE PRIOR TO THE STARTING TIME FOR THE PRE-BID. BIDDERS WHO ARRIVE LATE, BUT PRIOR TO THE DISMISSAL OF THE TECHNICAL PORTION OF THE PRE-BID WILL BE PERMITTED TO SIGN IN. BIDDERS WHO ARRIVE AFTER CONCLUSION OF THE TECHNICAL PORTION OF THE PRE-BID, BUT DURING ANY SUBSEQUENT PART OF THE PRE-BID WILL NOT BE PERMITTED TO SIGN THE ATTENDANCE SHEET.</p> <p>TECHNICAL QUESTIONS CONCERNING THIS SOLICITATION MUST BE SUBMITTED IN WRITING TO KRISTA FERRELL IN THE WEST VIRGINIA STATE PURCHASING DIVISION VIA MAIL AT THE ADDRESS SHOWN IN THE BODY OF THIS RFQ, VIA FAX AT 304-558-4115, OR VIA EMAIL AT KRISTA.S.FERRELL@WV.GOV. DEADLINE FOR ALL TECHNICAL QUESTIONS IS 08/14/2009 AT THE CLOSE OF BUSINESS. ALL TECHNICAL QUESTIONS RECEIVED, IF ANY, WILL BE ADDRESSED BY ADDENDUM AFTER THE DEADLINE HAS LAPSED.</p> <p>QUESTIONS CONCERNING THE PROCESS BY WHICH A VENDOR MAY SUBMIT A BID TO THE STATE OF WEST VIRGINIA ARE NOT CONSIDERED TO BE TECHNICAL QUESTIONS AND MAY BE SUBMITTED AT ANY TIME PRIOR TO THE BID OPENING AND IN ANY FORMAT.</p> <p>EXHIBIT 10</p> <p style="text-align: right;">REQUISITION NO. :</p>						

SEE REVERSE SIDE FOR TERMS AND CONDITIONS

SIGNATURE _____ TELEPHONE _____ DATE _____

TITLE _____ FEIN _____ ADDRESS CHANGES TO BE NOTED ABOVE

WHEN RESPONDING TO RFQ, INSERT NAME AND ADDRESS IN SPACE ABOVE LABELED 'VENDOR'



State of West Virginia
 Department of Administration
 Purchasing Division
 2019 Washington Street East
 Post Office Box 50130
 Charleston, WV 25305-0130

Request for Quotation

RFQ NUMBER
DNR209199

PAGE
3

ADDRESS CORRESPONDENCE TO ATTENTION OF:
KRISTA FERRELL 804-558-2596

VENDOR ROOM

RFQ COPY
 TYPE NAME/ADDRESS HERE

SHIP TO

DIVISION OF NATURAL RESOURCES
 BABCOCK STATE PARK
 ATTN: PARK SUPERINTENDENT
 HC 35, BOX 150
 CLIFFTOP, WV
 25831 438-5662

DATE PRINTED	TERMS OF SALE	SHIP VIA	F.O.B.	FREIGHT TERMS
07/30/2009				

BID OPENING DATE: 09/01/2009 BID OPENING TIME 01:30PM

LINE	QUANTITY	UOP	CAT NO.	ITEM NUMBER	UNIT PRICE	AMOUNT
ADDENDUM ACKNOWLEDGEMENT						
I HEREBY ACKNOWLEDGE RECEIPT OF THE FOLLOWING CHECKED ADDENDUM(S) AND HAVE MADE THE NECESSARY REVISIONS TO MY PROPOSAL, PLANS AND/OR SPECIFICATION, ETC.						
ADDENDUM NO. 'S:						
NO. 1						
NO. 2						
NO. 3						
NO. 4						
NO. 5						
I UNDERSTAND THAT FAILURE TO CONFIRM THE RECEIPT OF THE ADDENDUM(S) MAY BE CAUSE FOR REJECTION OF BIDS.						
VENDOR MUST CLEARLY UNDERSTAND THAT ANY VERBAL REPRESENTATION MADE OR ASSUMED TO BE MADE DURING ANY ORAL DISCUSSION HELD BETWEEN VENDOR'S REPRESENTATIVES AND ANY STATE PERSONNEL IS NOT BINDING. ONLY THE INFORMATION ISSUED IN WRITING AND ADDED TO THE SPECIFICATIONS BY AN OFFICIAL ADDENDUM IS BINDING.						
..... SIGNATURE						
..... COMPANY						

SEE REVERSE SIDE FOR TERMS AND CONDITIONS			
SIGNATURE	TELEPHONE	DATE	
TITLE	FEIN	ADDRESS CHANGES TO BE NOTED ABOVE	

WHEN RESPONDING TO RFQ, INSERT NAME AND ADDRESS IN SPACE ABOVE LABELED 'VENDOR'



State of West Virginia
 Department of Administration
 Purchasing Division
 2019 Washington Street East
 Post Office Box 50130
 Charleston, WV 25305-0130

Request for Quotation

RFQ NUMBER
DNR209199

PAGE
4

ADDRESS CORRESPONDENCE TO ATTENTION OF:
KRISTA FERRELL 804-558-2596

RFQ COPY
 TYPE NAME/ADDRESS HERE

VENDOR

SHIP TO

DIVISION OF NATURAL RESOURCES
 BABCOCK STATE PARK
 ATTN: PARK SUPERINTENDENT
 HC 35, BOX 150
 CLIFFTOP, WV
 25831 438-5662

DATE PRINTED	TERMS OF SALE	SHIP VIA	F.O.B.	FREIGHT TERMS
07/30/2009				

BID OPENING DATE: 09/01/2009 BID OPENING TIME 01:30PM

LINE	QUANTITY	UOP	CAT NO.	ITEM NUMBER	UNIT PRICE	AMOUNT
				DATE		
				REV. 11/96		
				THE MODEL/BRAND/SPECIFICATIONS NAMED HEREIN ESTABLISH THE ACCEPTABLE LEVEL OF QUALITY ONLY AND ARE NOT INTENDED TO REFLECT A PREFERENCE OR FAVOR ANY PARTICULAR BRAND OR VENDOR. VENDORS WHO ARE BIDDING ALTERNATES SHOULD SO STATE AND INCLUDE PERTINENT LITERATURE AND SPECIFICATIONS. FAILURE TO PROVIDE INFORMATION FOR ANY ALTERNATES MAY BE GROUNDS FOR REJECTION OF THE BID. THE STATE RESERVES THE RIGHT TO WAIVE MINOR IRREGULARITIES IN BIDS OR SPECIFICATIONS IN ACCORDANCE WITH SECTION 148-1-4 (F) OF THE WEST VIRGINIA LEGISLATIVE RULES AND REGULATIONS.		
				BANKRUPTCY: IN THE EVENT THE VENDOR/CONTRACTOR FILES FOR BANKRUPTCY PROTECTION, THE STATE MAY DEEM THE CONTRACT NULL AND VOID, AND TERMINATE SUCH CONTRACT WITHOUT FURTHER ORDER.		
				NOTICE		
				A SIGNED BID MUST BE SUBMITTED TO:		
				DEPARTMENT OF ADMINISTRATION PURCHASING DIVISION BUILDING 15 2019 WASHINGTON STREET, EAST CHARLESTON, WV 25305-0130		
				THE BID SHOULD CONTAIN THIS INFORMATION ON THE FACE OF		

SEE REVERSE SIDE FOR TERMS AND CONDITIONS

SIGNATURE	TELEPHONE	DATE
-----------	-----------	------

TITLE	FEIN	ADDRESS CHANGES TO BE NOTED ABOVE
-------	------	-----------------------------------

WHEN RESPONDING TO RFQ, INSERT NAME AND ADDRESS IN SPACE ABOVE LABELED 'VENDOR'



State of West Virginia
 Department of Administration
 Purchasing Division
 2019 Washington Street East
 Post Office Box 50130
 Charleston, WV 25305-0130

Request for Quotation

RFQ NUMBER
DNR209199

PAGE
5

ADDRESS CORRESPONDENCE TO ATTENTION OF:
KRISTA FERRELL 804-558-2596

VENDOR

RFQ COPY
 TYPE NAME/ADDRESS HERE

SHIP TO

DIVISION OF NATURAL RESOURCES
 BABCOCK STATE PARK
 ATTN: PARK SUPERINTENDENT
 HC 35, BOX 150
 CLIFFTOP, WV
 25831 438-5662

DATE PRINTED	TERMS OF SALE	SHIP VIA	F.O.B.	FREIGHT TERMS
07/30/2009				

BID OPENING DATE: 09/01/2009 BID OPENING TIME 01:30PM

LINE	QUANTITY	UOP	CAT NO.	ITEM NUMBER	UNIT PRICE	AMOUNT
THE ENVELOPE OR THE BID MAY NOT BE CONSIDERED: SEALED BID BUYER: KRISTA FERRELL-FILE 21 RFQ. NO.: DNR209199 BID OPENING DATE: 09/01/2009 BID OPENING TIME: 1:30 PM PLEASE PROVIDE A FAX NUMBER IN CASE IT IS NECESSARY TO CONTACT YOU REGARDING YOUR BID: ----- CONTACT PERSON (PLEASE PRINT CLEARLY): ----- ***** THIS IS THE END OF RFQ DNR209199 ***** TOTAL: _____						

SEE REVERSE SIDE FOR TERMS AND CONDITIONS

SIGNATURE	TELEPHONE	DATE
TITLE	FEIN	ADDRESS CHANGES TO BE NOTED ABOVE

WHEN RESPONDING TO RFQ, INSERT NAME AND ADDRESS IN SPACE ABOVE LABELED 'VENDOR'

WVDNR209199
Babcock State Park Playground Specifications

To supply playground equipment to offer play activities for children ages five (5) to twelve (12) at Babcock State Park, Clifftop, West Virginia. Playground equipment will be purchased for three separate areas in the park. Park personnel will install all playground equipment. F.O.B. Destination. Freight and/or delivery charges are to be included in the price of the goods. Delivery should be made within thirty (30) days of purchase order award. The award may be split if it is in the best interest of the West Virginia Division of Natural Resource

CAMPGROUND AREA PLAYGROUND

PowerScape meadow place play structure, Item #G85172, or equal. Structure must have the same type of play events including the minimum number in the specified Item; and uprights and support bars must be constructed of galvanized steel

PrimeTime swing frame, Item #12583, or equal. Swing frame must have a minimum 3 ½" OD; must have an arched style top rail; must be a minimum 8' installed height; must be constructed of galvanized steel; and must accommodate two swing units.

PrimeTime swing add-a-bay, Item #12584, or equal. Frame must have a minimum 3 ½" OD; must have an arched style top rail; must be minimum 8' installed height; must be constructed of galvanized steel; and must accommodate two swing units.

PrimeTime 3 ½" enclosed tot swing with galvanized chain, Item #8696, or equal.

PrimeTime 3 ½" belt seat with galvanized chain, Item #8910, or equal.

Geo-textile fabric or equal. Fabric must provide a water permeable separation between the earth and the wood fiber and at least 150 gallons per square foot per minute.

Engineered wood fiber @ 8" compacted depth or equal. Material must be recently harvested and debarked; free of chemical treatments and additives; free of soil, twigs, leaves and other contaminants.

One (1) day of supervision by successful vendor. Park personnel will install all playground equipment and this will provide oversight to ensure that all equipment is assembled and installed properly according to manufacturer's guidelines

MANN'S CREEK PICNIC AREA PLAYGROUND

WVDNR209199
Babcock State Park Playground Specifications

PlayworldSystems challengers play structure, Item #350-0704, or equal. Structure must have at least the same type of play events including the minimum number in the specified Item and the uprights and support bars must be constructed of galvanized steel.

PrimeTime swing frame, Item #12583, or equal. Swing frame must have a minimum 3 ½" OD; must have an arched style top rail; must be a minimum 8' installed height; must be constructed of galvanized steel; and must accommodate two swing units.

PrimeTime swing-a-bay, Item #12584, or equal. Frame must have a minimum 3 ½" OD; must have an arched style top rail; must be minimum 8' installed height; must be constructed of galvanized steel; and must accommodate two swing units.

PrimeTime 3 ½" belt seat with galvanized chain, Item #8910, or equal.

PrimeTime 3 ½" enclosed tot swing with galvanized chain, Item #8696, or equal.

Geo-textile fabric or equal. Fabric must provide a water permeable separation between the earth and the wood fiber and at least 150 gallons per square foot per minute.

Engineered wood fiber @ 8" compacted depth or equal. Material must be recently harvested and debarked; free of chemical treatments and additives; free of soil, twigs, leaves and other contaminants.

One (1) day of supervision by successful vendor. Park personnel will install all playground equipment and this will provide oversight to ensure that all equipment is assembled and installed properly according to manufacturer's guidelines.

SUGAR CAMP RUN PICNIC AREA PLAYGROUND

PowerScape meadow place play structure, Item #G85172, or equal. Structure must have the same type of play events including the minimum number in the specified Item; and uprights and support bars must be constructed of galvanized steel.

PrimeTime swing frame, Item #12583, or equal. Swing frame must have a minimum 3 ½" OD; must have an arched style top rail; must be a minimum 8' installed height; must be constructed of galvanized steel; and must accommodate two swing units.

PrimeTime Swing add-a bay Item #12584, or equal. Frame must have a minimum 3 ½" OD; must have an arched style top rail; must be minimum 8' installed height; must be constructed of galvanized steel; and must accommodate two swing units.

PrimeTime 3 ½" belt seat with galvanized chain, Item #8910, or equal.

WVDNR209199
Babcock State Park Playground Specifications

PrimeTime 3 ½" enclosed tot swing with galvanized chain, Item #8696, or equal.

Geo-textile fabric or equal. Fabric must provide a water permeable separation between the earth and the wood fiber and at least 150 gallons per square foot per minute.

Engineered wood fiber @ 8" compacted depth or equal. Material must be recently harvested and debarked; free of chemical treatments and additives; free of soil, twigs, leaves and other contaminants.

One (1) day of supervision by successful vendor. Park personnel will install all playground equipment and this will provide oversight to ensure that all equipment is assembled and installed properly according to manufacturer's guidelines.

WVDNR209199
Babcock State Park Playground Specifications

All playground equipment and engineered wood fiber must meet the following requirements:

- Compliance with U.S. Consumer Product Safety Commission, Handbook for Public Playground Safety.
- Compliance with ASTM Standard F 1487.
- Compliance with Architectural and Transportation Barriers Compliance Board, Americans with Disabilities Act (ADA) Accessibility Guidelines for Buildings and Facilities; Play Areas.

Vendors must submit the following attachments:

- Complete manufacturer's parts specifications and warranties
- Layout drawing to scale of the proposed play structure or equipment.
- ASTM and CPSC Statement of Compliance

Warranties:

- All equipment and engineered wood fiber must be guaranteed to be free of defects in workmanship and material for a minimum of one year from date of acceptance. However, if manufacturer warranty periods are longer than the required minimum one year warranty, those warranties shall apply.

Color scheme of equipment must be coordinated with Babcock State Park. Color of Items will be selected from manufacturer's standard colors.

A mandatory pre-bid conference will be held on, August 10, 2009, at Babcock State Park Headquarters at 1:30 p.m. A failure to attend the mandatory pre-bid conference will result in bid disqualification. An individual may not represent more than one firm at the pre-bid conference.

WVDNR209199
Babcock State Park Playground Specifications

Pricing Sheet:

Vendors must provide unit prices for all line items. Failure to provide unit prices will result in the disqualification of the vendor's bid.

WVDNR209199
Babcock State Park
PLAYGROUND EQUIPMENT SHEET

Please complete the below information concerning the brand(s) of equipment being bid in relation to this project. If bidding "or equal" brands, please attach manufacturer's literature documenting that it meets the mandatory requirements stated in the specifications. Vendors should note the areas of the provided manufacturer's literature that adheres to the mandatory requirements outlined in the Request For Quotation.

Item No.	Equipment	Manufacturer	Item
1	Campground Area Playground PowerScape meadow place play structure, Item #G85172, or equal.		
2	Campground Area Playground Primetime swing frame, Item #12583, or equal.		
3	Campground Area Playground Primetime swing add-a-bay, Item #12584, or equal.		
4	Campground Area Playground PrimeTime 3½" enclosed tot swing with galvanized chain, Item #8696, or equal.		
5	Campground Area Playground PrimeTime 3½" belt seat with galvanized chain, Item #8910, or equal.		
6	Campground Area Playground geo-textile fabric or equal.		
7	Campground Area Playground engineered wood fiber @ 8" compacted depth or equal.		
8	Campground Area Playground one (1) day of supervision by successful vendor.		
9	Manns Creek Picnic Area Playground PlayworldSystems challengers play structure, Item #350-0704, or equal.		
10	Manns Creek Picnic Area Playground PrimeTime swing frame, Item #12583, or equal.		

WVDNR209199
Babcock State Park
PLAYGROUND EQUIPMENT SHEET

Item No.	Equipment	Manufacturer	Item
11	Manns Creek Picnic Area Playground PrimeTime swing add- a-bay, Item #12584, or equal.		
12	Manns Creek Picnic Area Playground PrimeTime 3½" belt seat with galvanized chain, Item # 8910, or equal.		
13	Manns Creek Picnic Area Playground PrimeTime 3½" enclosed tot swing with galvanized chain, Item #8696, or equal.		
14	Manns Creek Picnic Area Playground geo-textile fabric or equal.		
15	Manns Creek Picnic Area Playground engineered wood fiber @ 8" compacted depth or equal.		
16	Manns Creek Picnic Area Playground one (1) day of supervision by successful vendor.		
17	Sugar Camp Run Picnic Area Playground PowerScape meadow place play structure , Item #g85172, or equal.		
18	Sugar Camp Run Picnic Area Playground Primetime swing frame, Item #21583, or equal.		
19	Sugar Camp Run Picnic Area Playground Primetime swing add- a-bay, Item #21584, or equal.		
20	Sugar Camp Run Picnic Area Playground PrimeTime 3½" enclosed tot swing with galvanized chain, Item #8696, or equal.		

WVDNR209199
Babcock State Park
PLAYGROUND EQUIPMENT SHEET

Item No.	Equipment	Manufacturer	Item
21	Sugar Camp Run Picnic Area Playground PrimeTime 3½" belt seat with galvanized chain, Item #8910, or equal.		
22	Sugar Camp Run Picnic Area Playground geo-textile fabric or equal.		
23	Sugar Camp Run Picnic Area Playground engineered wood fiber @ 8" compacted depth or equal.		
24	Sugar Camp Run Picnic Area Playground one (1) day of supervision by successful vendor.		

**Babcock State Park Playground Equipment
PRICING SHEET**

Item No.	Quantity	Description	Unit Price	Amount
1	1	Campground Area Playground PowerScape meadow place play structure, Item #G85172, or equal.		
2	1	Campground Area Playground Primetime swing frame, Item #12583, or equal.		
3	1	Campground Area Playground Primetime swing add-a-bay, Item #12584, or equal.		
4	1	Campground Area Playground PrimeTime 3½" enclosed tot swing with galvanized chain, Item #8696, or equal.		
5	3	Campground Area Playground PrimeTime 3½" belt seat with galvanized chain, Item #8910, or equal.		
6	3,432 square feet	Campground Area Playground geo-textile fabric square foot roll or equal.	PLEASE NOTE: Bidders must include a unit price. This item cannot be bid Lump Sum. 1 square foot x price = per unit price.	
7	3,432 square feet	Campground Area Playground engineered wood fiber @ 8" compacted depth or equal.	PLEASE NOTE: Bidders must include a unit price. This item cannot be bid Lump Sum. 1 square foot x price = per unit price.	
8	1	Campground Area Playground one (1) day of supervision by successful vendor.		
9	1	Manns Creek Picnic Area Playground PlayworldSystems challengers play structure, Item #350-0704, or equal.		

**Babcock State Park Playground Equipment
PRICING SHEET**

Item No.	Quantity	Description	Unit Price	Amount
10	1	Manns Creek Picnic Area Playground PrimeTime swing frame, Item #12583, or equal.		
11	1	Manns Creek Picnic Area Playground PrimeTime swing add-a-bay, Item #12584, or equal.		
12	3	Manns Creek Picnic Area Playground PrimeTime 3½" belt seat with galvanized chain, Item # 8910, or equal.		
13	1	Manns Creek Picnic Area Playground PrimeTime 3½" enclosed tot swing with galvanized chain, Item #8696, or equal.		
14	3,192 square feet	Manns Creek Picnic Area Playground geo-textile fabric or equal.	PLEASE NOTE: Bidders must include a unit price. This Item cannot be bid Lump Sum. 1 square foot x price = per unit price.	
15	3,192 square feet	Manns Creek Picnic Area Playground engineered wood fiber @ 8" compacted depth or equal.	PLEASE NOTE: Bidders must include a unit price. This Item cannot be bid Lump Sum 1 square foot x price = per unit price.	
16	1	Manns Creek Picnic Area Playground one (1) day of supervision by successful vendor.		
17	1	Sugar Camp Run Picnic Area Playground PowerScape meadow place play structure , Item #g85172, or equal.		
18	1	Sugar Camp Run Picnic Area Playground Primetime swing frame, Item #21583, or equal.		

Babcock State Park Playground Equipment
PRICING SHEET

Item No.	Quantity	Description	Unit Price	Amount
19	1	Sugar Camp Run Picnic Area Playground Primetime swing add-a-bay, Item #21584, or equal.		
20	1	Sugar Camp Run Picnic Area Playground PrimeTime 3½" enclosed tot swing with galvanized chain, Item #8696, or equal.		
21	3	Sugar Camp Run Picnic Area Playground PrimeTime 3½" belt seat with galvanized chain, Item #8910, or equal.		
22	2,592 square feet	Sugar Camp Run Picnic Area Playground geo-textile fabric or equal.	PLEASE NOTE: Bidders must include a unit price. This Item cannot be bid Lump Sum. 1 square foot x price = per unit price.	
23	2,592 square feet	Sugar Camp Run Picnic Area Playground engineered wood fiber @ 8" compacted depth or equal.	PLEASE NOTE: Bidders must include a unit price. This Item cannot be bid Lump Sum. 1 square foot x price = per unit price.	
24	1	Sugar Camp Run Picnic Area Playground one (1) day of supervision by successful vendor.		
		TOTALS		

MEADOW PLACE MODEL VIEW

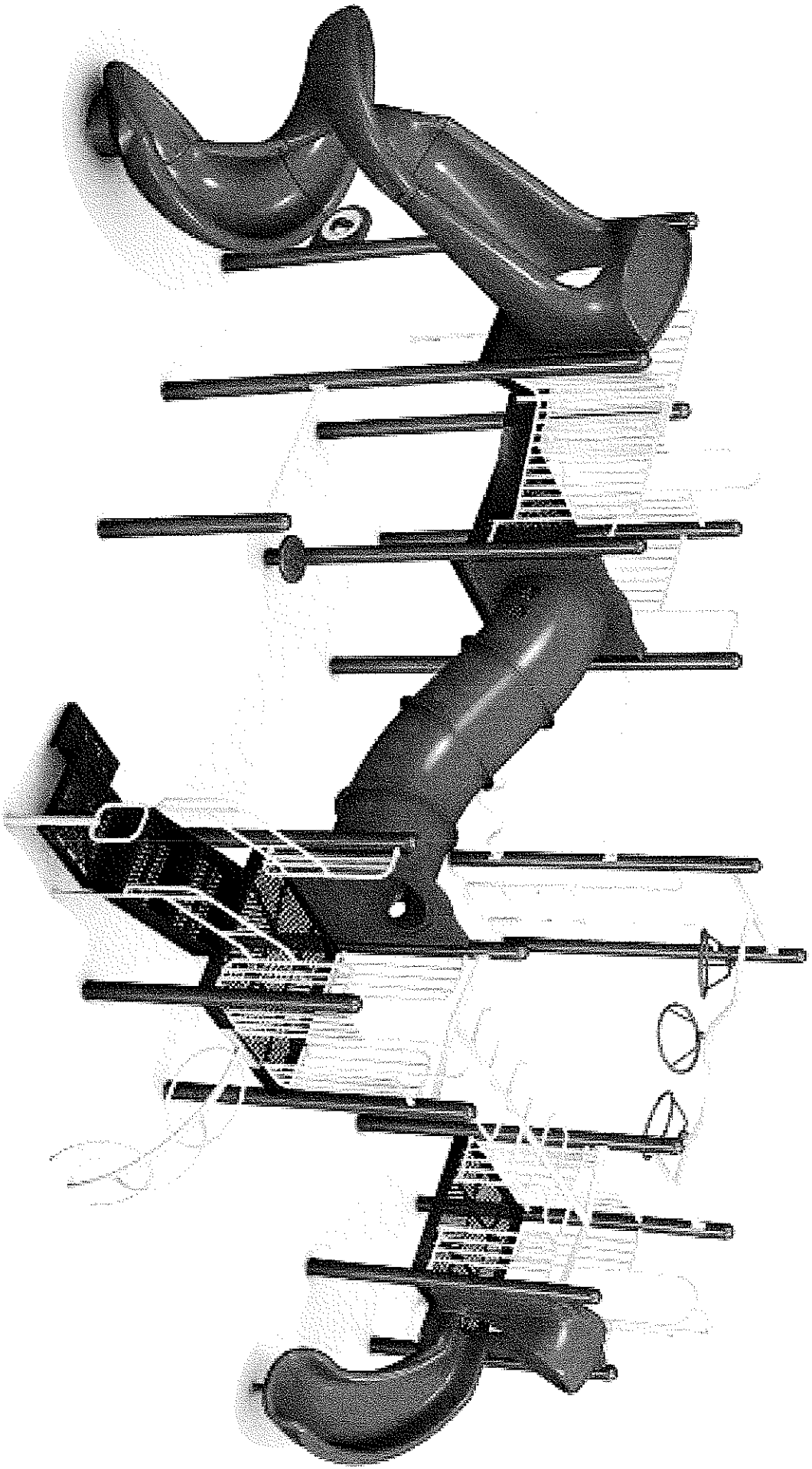

Wilderslide

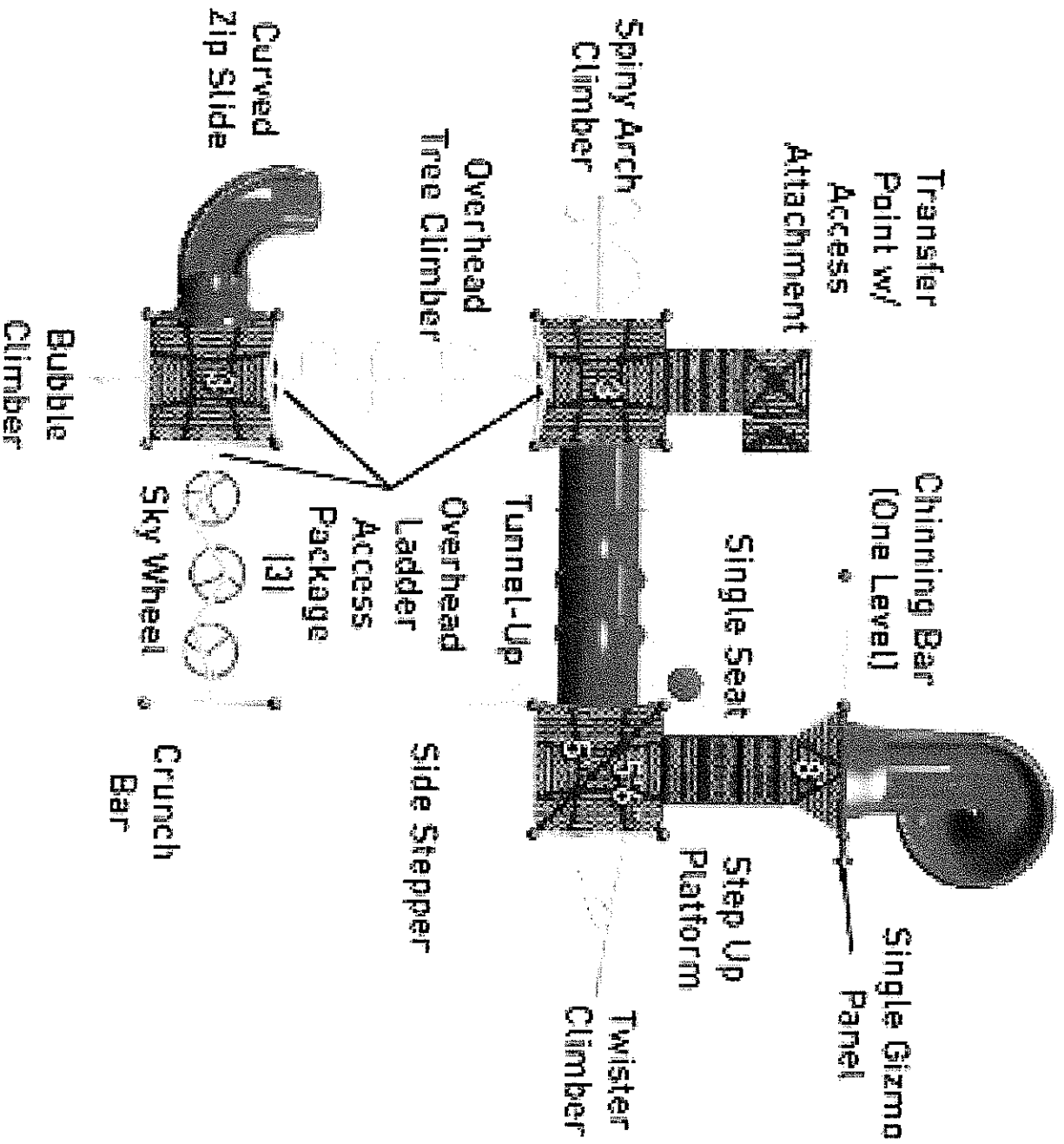

PRIME TIME SWING FRAME 12583

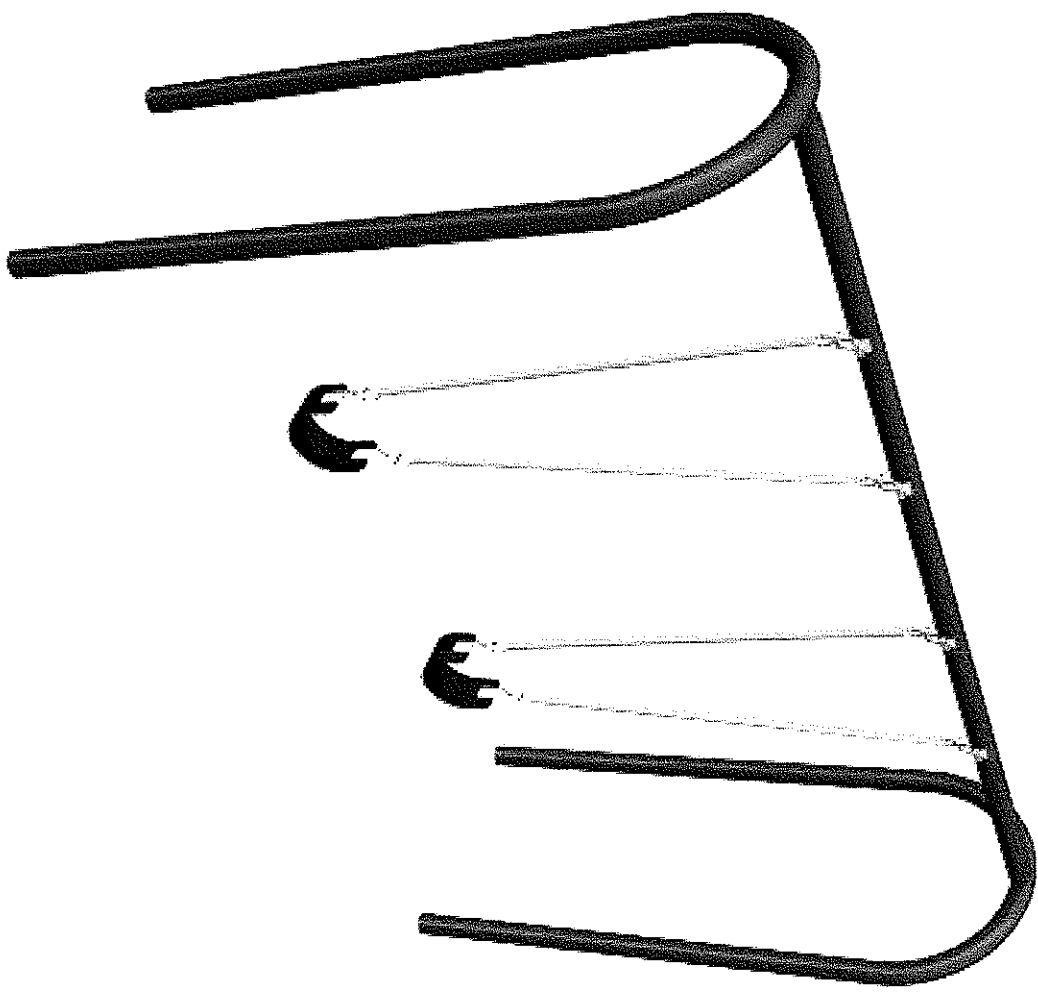

PLAYWORLD SYSTEMS CHALLENGERS
#350-0704 MODEL VIEW

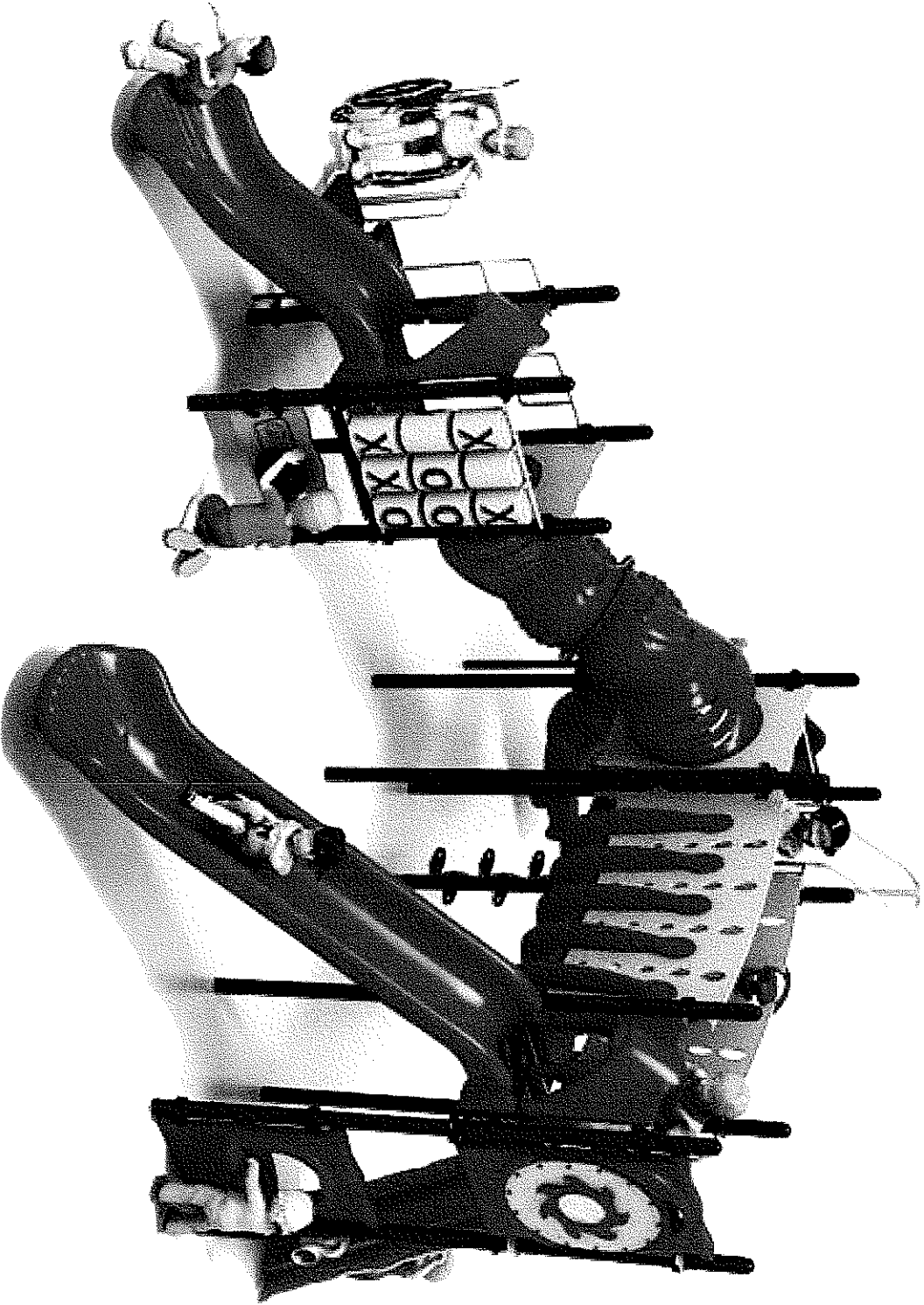

PLAYWORLD SYSTEMS CHALLENGERS
#350-0704 TOP VIEW

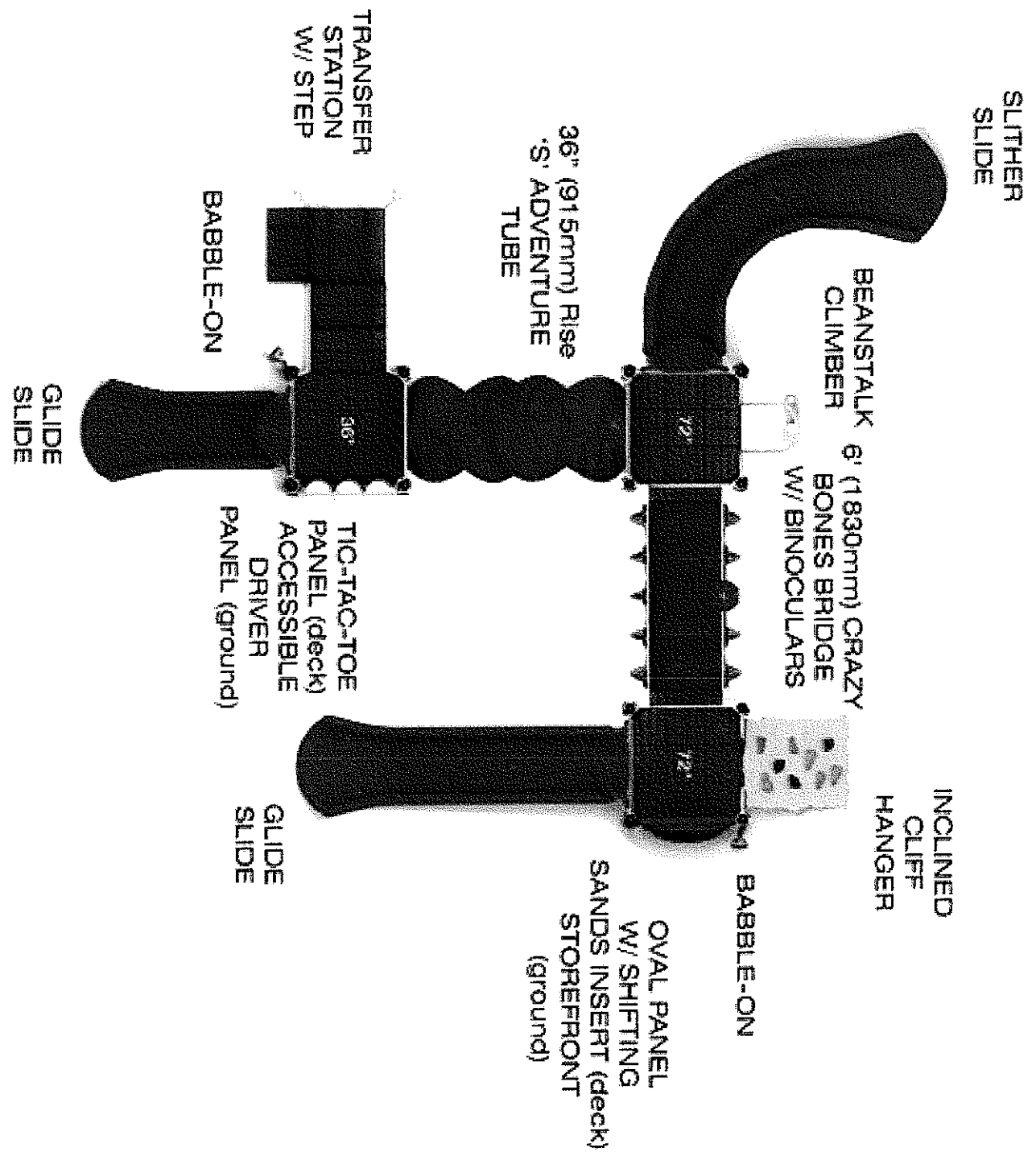

SLITHER
SLIDE

BEANSTALK
CLIMBER 6' (1830mm) CRAZY
BONES BRIDGE
W/ BINOCULARS

INCLINED
CLIFF
HANGER

36" (915mm) Rise
.S. ADVENTURE
TUBE

BABBLE-ON

GLIDE
SLIDE

TIC-TAC-TOE
PANEL (deck)
ACCESSIBLE
DRIVER
PANEL (ground)

GLIDE
SLIDE

OVAL PANEL
W/ SHIFTING
SANDS INSERT (deck)
STOREFRONT
(ground)

BABBLE-ON

State of West Virginia **VENDOR PREFERENCE CERTIFICATE**

Certification and application* is hereby made for Preference in accordance with **West Virginia Code, §5A-3-37** (Does not apply to construction contracts). **West Virginia Code, §5A-3-37**, provides an opportunity for qualifying vendors to request (at the time of bid) preference for their residency status. Such preference is an evaluation method only and will be applied only to the cost bid in accordance with the **West Virginia Code**. This certificate for application is to be used to request such preference. The Purchasing Division will make the determination of the Resident Vendor Preference, if applicable.

- 1. **Application is made for 2.5% resident vendor preference for the reason checked:**
 Bidder is an individual resident vendor and has resided continuously in West Virginia for four (4) years immediately preceding the date of this certification; **or,**
 Bidder is a partnership, association or corporation resident vendor and has maintained its headquarters or principal place of business continuously in West Virginia for four (4) years immediately preceding the date of this certification; or 80% of the ownership interest of Bidder is held by another individual, partnership, association or corporation resident vendor who has maintained its headquarters or principal place of business continuously in West Virginia for four (4) years immediately preceding the date of this certification; **or,**
 Bidder is a nonresident vendor which has an affiliate or subsidiary which employs a minimum of one hundred state residents and which has maintained its headquarters or principal place of business within West Virginia continuously for the four (4) years immediately preceding the date of this certification; **or,**
- 2. **Application is made for 2.5% resident vendor preference for the reason checked:**
 Bidder is a resident vendor who certifies that, during the life of the contract, on average at least 75% of the employees working on the project being bid are residents of West Virginia who have resided in the state continuously for the two years immediately preceding submission of this bid; **or,**
- 3. **Application is made for 2.5% resident vendor preference for the reason checked:**
 Bidder is a nonresident vendor employing a minimum of one hundred state residents or is a nonresident vendor with an affiliate or subsidiary which maintains its headquarters or principal place of business within West Virginia employing a minimum of one hundred state residents who certifies that, during the life of the contract, on average at least 75% of the employees or Bidder's affiliate's or subsidiary's employees are residents of West Virginia who have resided in the state continuously for the two years immediately preceding submission of this bid; **or,**
- 4. **Application is made for 5% resident vendor preference for the reason checked:**
 Bidder meets either the requirement of both subdivisions (1) and (2) or subdivision (1) and (3) as stated above; **or,**
- 5. **Application is made for 3.5% resident vendor preference who is a veteran for the reason checked:**
 Bidder is an individual resident vendor who is a veteran of the United States armed forces, the reserves or the National Guard and has resided in West Virginia continuously for the four years immediately preceding the date on which the bid is submitted; **or,**
- 6. **Application is made for 3.5% resident vendor preference who is a veteran for the reason checked:**
 Bidder is a resident vendor who is a veteran of the United States armed forces, the reserves or the National Guard, if, for purposes of producing or distributing the commodities or completing the project which is the subject of the vendor's bid and continuously over the entire term of the project, on average at least seventy-five percent of the vendor's employees are residents of West Virginia who have resided in the state continuously for the two immediately preceding years

Bidder understands if the Secretary of Revenue determines that a Bidder receiving preference has failed to continue to meet the requirements for such preference, the Secretary may order the Director of Purchasing to: (a) reject the bid; or (b) assess a penalty against such Bidder in an amount not to exceed 5% of the bid amount and that such penalty will be paid to the contracting agency or deducted from any unpaid balance on the contract or purchase order.

By submission of this certificate, Bidder agrees to disclose any reasonably requested information to the Purchasing Division and authorizes the Department of Revenue to disclose to the Director of Purchasing appropriate information verifying that Bidder has paid the required business taxes, provided that such information does not contain the amounts of taxes paid nor any other information deemed by the Tax Commissioner to be confidential.

Under penalty of law for false swearing (West Virginia Code, §61-5-3), Bidder hereby certifies that this certificate is true and accurate in all respects; and that if a contract is issued to Bidder and if anything contained within this certificate changes during the term of the contract, Bidder will notify the Purchasing Division in writing immediately.

Bidder: _____ **Signed:** _____

Date: _____ **Title:** _____

**Check any combination of preference consideration(s) indicated above, which you are entitled to receive.*

STATE OF WEST VIRGINIA
Purchasing Division

PURCHASING AFFIDAVIT

VENDOR OWING A DEBT TO THE STATE:

West Virginia Code §5A-3-10a provides that: No contract or renewal of any contract may be awarded by the state or any of its political subdivisions to any vendor or prospective vendor when the vendor or prospective vendor or a related party to the vendor or prospective vendor is a debtor and the debt owed is an amount greater than one thousand dollars in the aggregate.

PUBLIC IMPROVEMENT CONTRACTS & DRUG-FREE WORKPLACE ACT:

If this is a solicitation for a public improvement construction contract, the vendor, by its signature below, affirms that it has a written plan for a drug-free workplace policy in compliance with Article 1D, Chapter 21 of the *West Virginia Code*. The vendor **must** make said affirmation with its bid submission. Further, public improvement construction contract may not be awarded to a vendor who does not have a written plan for a drug-free workplace policy in compliance with Article 1D, Chapter 21 of the *West Virginia Code* and who has not submitted that plan to the appropriate contracting authority in timely fashion. For a vendor who is a subcontractor, compliance with Section 5, Article 1D, Chapter 21 of the *West Virginia Code* may take place before their work on the public improvement is begun.

ANTITRUST:

In submitting a bid to any agency for the state of West Virginia, the bidder offers and agrees that if the bid is accepted the bidder will convey, sell, assign or transfer to the state of West Virginia all rights, title and interest in and to all causes of action it may now or hereafter acquire under the antitrust laws of the United States and the state of West Virginia for price fixing and/or unreasonable restraints of trade relating to the particular commodities or services purchased or acquired by the state of West Virginia. Such assignment shall be made and become effective at the time the purchasing agency tenders the initial payment to the bidder.

I certify that this bid is made without prior understanding, agreement, or connection with any corporation, firm, limited liability company, partnership or person or entity submitting a bid for the same materials, supplies, equipment or services and is in all respects fair and without collusion or fraud. I further certify that I am authorized to sign the certification on behalf of the bidder or this bid.

LICENSING:

Vendors must be licensed and in good standing in accordance with any and all state and local laws and requirements by any state or local agency of West Virginia, including, but not limited to, the West Virginia Secretary of State's Office, the West Virginia Tax Department, West Virginia Insurance Commission, or any other state agencies or political subdivision. Furthermore, the vendor must provide all necessary releases to obtain information to enable the Director or spending unit to verify that the vendor is licensed and in good standing with the above entities.

CONFIDENTIALITY:

The vendor agrees that he or she will not disclose to anyone, directly or indirectly, any such personally identifiable information or other confidential information gained from the agency, unless the individual who is the subject of the information consents to the disclosure in writing or the disclosure is made pursuant to the agency's policies, procedures and rules. Vendor further agrees to comply with the Confidentiality Policies and Information Security Accountability Requirements, set forth in <http://www.state.wv.us/admin/purchase/privacy/noticeConfidentiality.pdf>.

Under penalty of law for false swearing (*West Virginia Code* §61-5-3), it is hereby certified that the vendor affirms and acknowledges the information in this affidavit and is in compliance with the requirements as stated.

Vendor's Name: _____

Authorized Signature: _____ Date: _____