



State of West Virginia
 Department of Administration
 Purchasing Division
 2019 Washington Street East
 Post Office Box 50130
 Charleston, WV 25305-0130

Request for Quotation

RFQ NUMBER
DEP14915

PAGE
1

ADDRESS CORRESPONDENCE TO ATTENTION OF
CHUCK BOWMAN
304-558-2157

RFQ COPY
TYPE NAME/ADDRESS HERE

VENDOR

SHIP TO

ENVIRONMENTAL PROTECTION
DEPARTMENT OF
OFFICE OF AML&R
601 57TH STREET SE
CHARLESTON, WV
25304 **304-926-0499**

DATE PRINTED	TERMS OF SALE	SHIP VIA	F.O.B.	FREIGHT TERMS
04/18/2010				

BID OPENING DATE: **05/06/2010** BID OPENING TIME **01:30PM**

LINE	QUANTITY	UOP	CAT. NO	ITEM NUMBER	UNIT PRICE	AMOUNT
***** ADDENDUM NO. 1 *****						
ADDENDUM ISSUED FOR THE PENINSULA HIGHWALL #1,2 PROJECT TO DISTRIBUTE THE PRE-BID SIGN-IN SHEETS, THE SPEC REVISIONS, REVISED BID SCHEDULE, AND REVISED DRAWINGS AS A RESULT OF THE MANDATORY PRE-BID MEETING ON 04/01/10.						
BID OPENING DATE AND TIME REMAIN UCHANGED AS 05/16/10 AT 1:30 PM.						
***** NO OTHER CHANGES *****						
0001	1	JB		962-73		
RECLAMATION: RESTORATION OF LAND & OTHER PROPERTIES						
***** THIS IS THE END OF RFQ DEP14915 ***** TOTAL: _____						

SEE REVERSE SIDE FOR TERMS AND CONDITIONS

SIGNATURE	TELEPHONE	DATE
TITLE	FEIN	ADDRESS CHANGES TO BE NOTED ABOVE

WHEN RESPONDING TO RFQ, INSERT NAME AND ADDRESS IN SPACE ABOVE LABELED 'VENDOR'

GENERAL TERMS & CONDITIONS
REQUEST FOR QUOTATION (RFQ) AND REQUEST FOR PROPOSAL (RFP)

1. Awards will be made in the best interest of the State of West Virginia.
 2. The State may accept or reject in part, or in whole, any bid.
 3. Prior to any award, the apparent successful vendor must be properly registered with the Purchasing Division and have paid the required \$125 fee.
 4. All services performed or goods delivered under State Purchase Order/Contracts are to be continued for the term of the Purchase Order/Contracts, contingent upon funds being appropriated by the Legislature or otherwise being made available. In the event funds are not appropriated or otherwise available for these services or goods this Purchase Order/Contract becomes void and of no effect after June 30.
 5. Payment may only be made after the delivery and acceptance of goods or services.
 6. Interest may be paid for late payment in accordance with the *West Virginia Code*.
 7. Vendor preference will be granted upon written request in accordance with the *West Virginia Code*.
 8. The State of West Virginia is exempt from federal and state taxes and will not pay or reimburse such taxes.
 9. The Director of Purchasing may cancel any Purchase Order/Contract upon 30 days written notice to the seller.
 10. The laws of the State of West Virginia and the *Legislative Rules* of the Purchasing Division shall govern the purchasing process.
 11. Any reference to automatic renewal is hereby deleted. The Contract may be renewed only upon mutual written agreement of the parties.
 12. **BANKRUPTCY:** In the event the vendor/contractor files for bankruptcy protection, the State may deem this contract null and void, and terminate such contract without further order.
 13. **HIPAA BUSINESS ASSOCIATE ADDENDUM:** The West Virginia State Government HIPAA Business Associate Addendum (BAA), approved by the Attorney General, is available online at www.state.wv.us/admin/purchase/vrc/hipaa.htm and is hereby made part of the agreement. Provided that the Agency meets the definition of a Cover Entity (45 CFR §160.103) and will be disclosing Protected Health Information (45 CFR §160.103) to the vendor.
 14. **CONFIDENTIALITY:** The vendor agrees that he or she will not disclose to anyone, directly or indirectly, any such personally identifiable information or other confidential information gained from the agency, unless the individual who is the subject of the information consents to the disclosure in writing or the disclosure is made pursuant to the agency's policies, procedures, and rules. Vendor further agrees to comply with the Confidentiality Policies and Information Security Accountability Requirements, set forth in <http://www.state.wv.us/admin/purchase/privacy/noticeConfidentiality.pdf>.
 15. **LICENSING:** Vendors must be licensed and in good standing in accordance with any and all state and local laws and requirements by any state or local agency of West Virginia, including, but not limited to, the West Virginia Secretary of State's Office, the West Virginia Tax Department, and the West Virginia Insurance Commission. The vendor must provide all necessary releases to obtain information to enable the director or spending unit to verify that the vendor is licensed and in good standing with the above entities.
 16. **ANTITRUST:** In submitting a bid to any agency for the State of West Virginia, the bidder offers and agrees that if the bid is accepted the bidder will convey, sell, assign or transfer to the State of West Virginia all rights, title and interest in and to all causes of action it may now or hereafter acquire under the antitrust laws of the United States and the State of West Virginia for price fixing and/or unreasonable restraints of trade relating to the particular commodities or services purchased or acquired by the State of West Virginia. Such assignment shall be made and become effective at the time the purchasing agency tenders the initial payment to the bidder.
- I certify that this bid is made without prior understanding, agreement, or connection with any corporation, firm, limited liability company, partnership, or person or entity submitting a bid for the same material, supplies, equipment or services and is in all respects fair and without collusion or fraud. I further certify that I am authorized to sign the certification on behalf of the bidder or this bid.

INSTRUCTIONS TO BIDDERS

1. Use the quotation forms provided by the Purchasing Division. Complete all sections of the quotation form.
2. Items offered must be in compliance with the specifications. Any deviation from the specifications must be clearly indicated by the bidder. Alternates offered by the bidder as **EQUAL** to the specifications must be clearly defined. A bidder offering an alternate should attach complete specifications and literature to the bid. The Purchasing Division may waive minor deviations to specifications.
3. Unit prices shall prevail in case of discrepancy. All quotations are considered F.O.B. destination unless alternate shipping terms are clearly identified in the quotation.
4. All quotations must be delivered by the bidder to the office listed below prior to the date and time of the bid opening. Failure of the bidder to deliver the quotations on time will result in bid disqualifications: Department of Administration, Purchasing Division, 2019 Washington Street East, P.O. Box 50130, Charleston, WV 25305-0130
5. Communication during the solicitation, bid, evaluation or award periods, except through the Purchasing Division, is strictly prohibited (W.Va. C.S.R. §148-1-6.6).

**Addendum #1 - Questions During Pre-Bid Meeting
For DEP14915
Peninsula Highwall #1 & #2**

The Contractor's work hours for this project will be 7:00 a.m. to 7:00 p.m. Monday through Friday. Work on Saturday, Sunday and major holidays shall not be allowed on this project.

- 1.) Section 5, **SCHEDULE OF WORK** of the Special Provisions shall be revised to indicate that work shall be restricted to 60 Hours per Week on this project.
- 2.) Sediment Control, as defined in Section 5, **SEDIMENT CONTROL** of the Technical Specifications shall be understood to consist of Silt Fence and not Hay Bales in order to be in compliance with the requirements of Water and Waste Management's NPDES Stormwater Permit.
- 3.) Section 8.1 of Section 8.0, **UNCLASSIFIED EXCAVATION** of the Technical Specifications shall be revised to indicate that the compaction requirement shall be 90% of standard proctor.
- 4.) Unless otherwise directed by the WVDEP Construction Supervisor during the course of the project, trees larger than eight inches in diameter at the stump that are cut as part of the clearing and grubbing operations shall not be stockpiled. Rather, it shall be the contractor's responsibility to burn or remove and dispose of the woody material from clearing and grubbing the site in accordance with all applicable laws, regulations, and/or required permits.
- 5.) The dry mine seal identified in the Plans shall be modified to incorporate a pipe with associated bat gate. The pipe shall be of sufficient diameter so as to equal the size of the existing opening to the mine. It shall also be of sufficient length so as to be installed into the opening and daylight past the limits of the backfilled highwall slope. The daylighted end of the pipe shall have a bat gate welded to the outer perimeter of the pipe. The bat gate shall conform to the attached detail. The bat gate should be installed between May 1 and August 31 in order to avoid disturbing hibernating bats.

This project shall be bid in accordance with the attached **Revised Bid Schedule**.

The Contractor shall have 90 days from the date of the Notice to Proceed to complete construction activities on the project. The \$250 per day liquidated damage clause will be in effect after the 90 days. However, the total performance period will be 365 days from the date of the Notice to Proceed for invoicing purposes.

14)

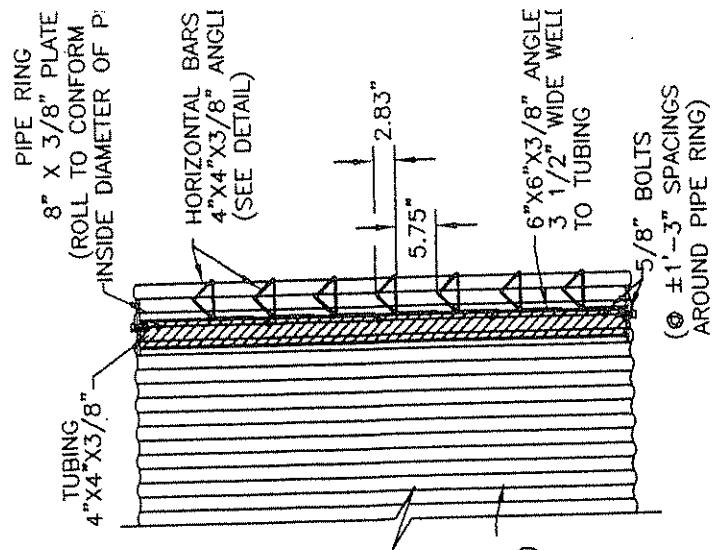
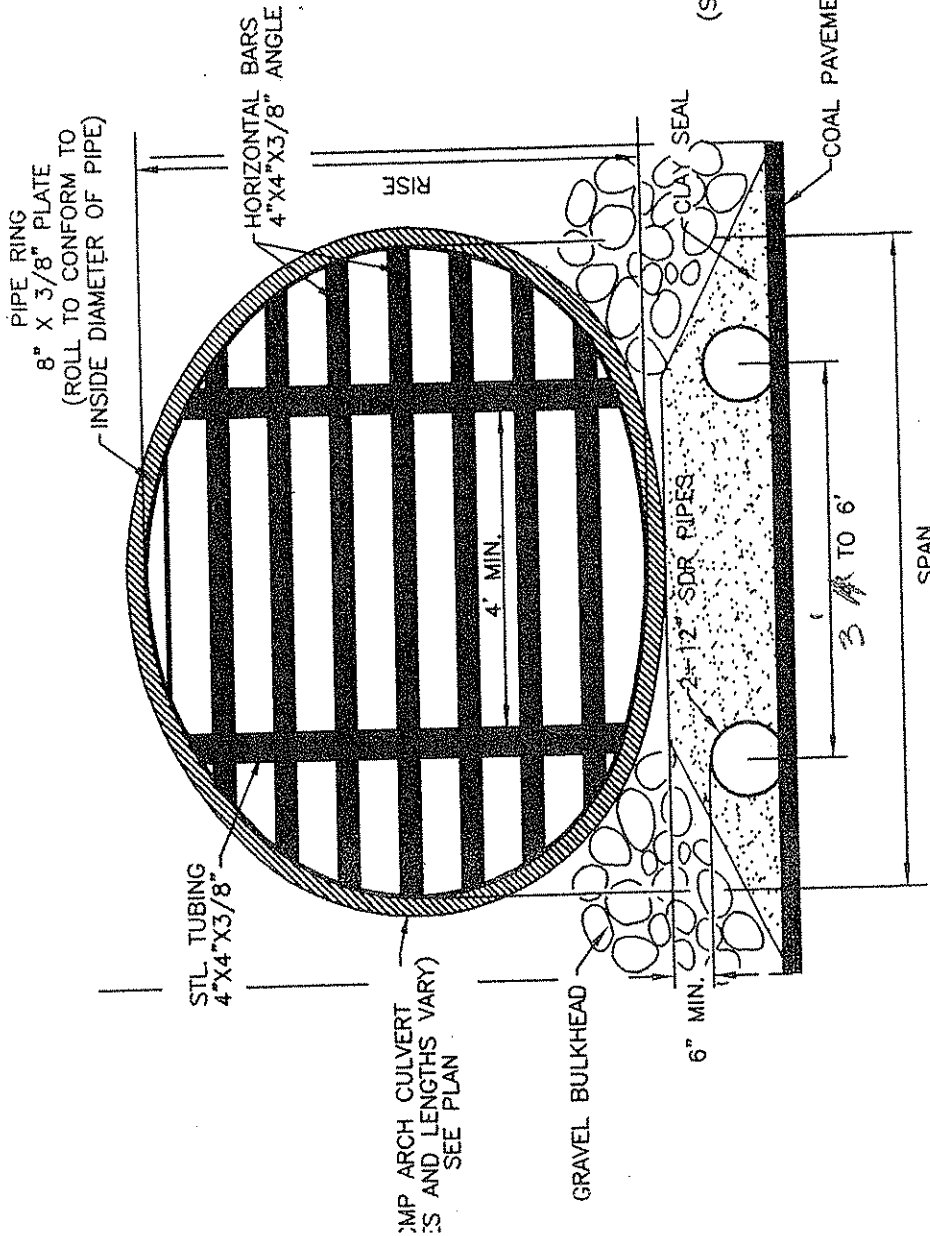

CMP ARCH CULVERT
(SIZES AND LENGTHS VARY)
SEE PLAN

PIPE RING SECTION

(ALTERNATE)

END VIEW

HORIZONTAL BAR SPACINGS ARE NOT TO BE ALTERED. AN ADDITIONAL HORIZONTAL "FLAT" BAR MAY BE REQUIRED TO MAINTAIN SPACINGS THROUGHOUT ENTIRE HEIGHT OF CULVERT. THESE MODIFICATIONS ARE TO BE APPROVED BY THE ENGINEER PRIOR TO BEING PERFORMED. *RS*

TYPICAL DETAIL PIPE BAT GATE

THE
 AS SHOWN AS TO NOT ALLOW ALL OF THE
 THE BARS TO BE WELDED TO THE 4" X 4" HORIZONTAL TUBING
 SPACED 4' APART FOR THE ENTIRE HEIGHT OF THE TUBING, THEN THE
 HORIZONTAL BARS NEEDED
 THE PIPE RING.

WEST VIRGINIA ENVIRONMENTAL
 601 57TH CHARLESTON, W

WEST VIRGINIA

MISCELLANEOUS DETAILS

Title

19

Drawing No.

5

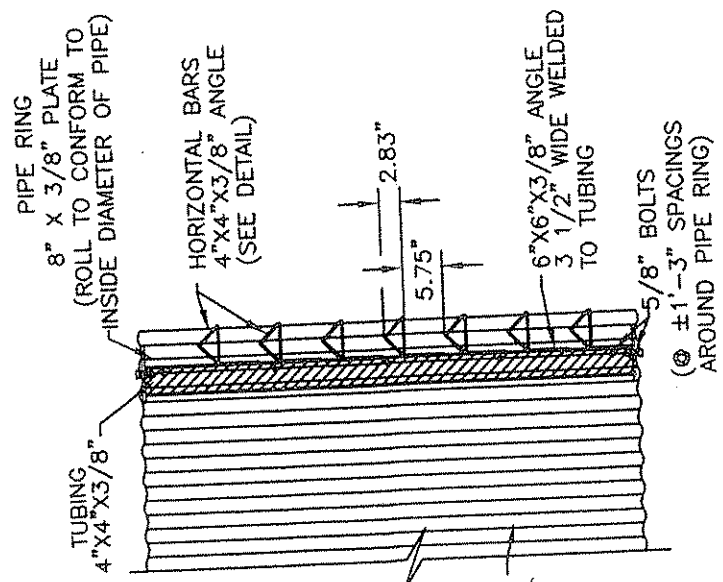
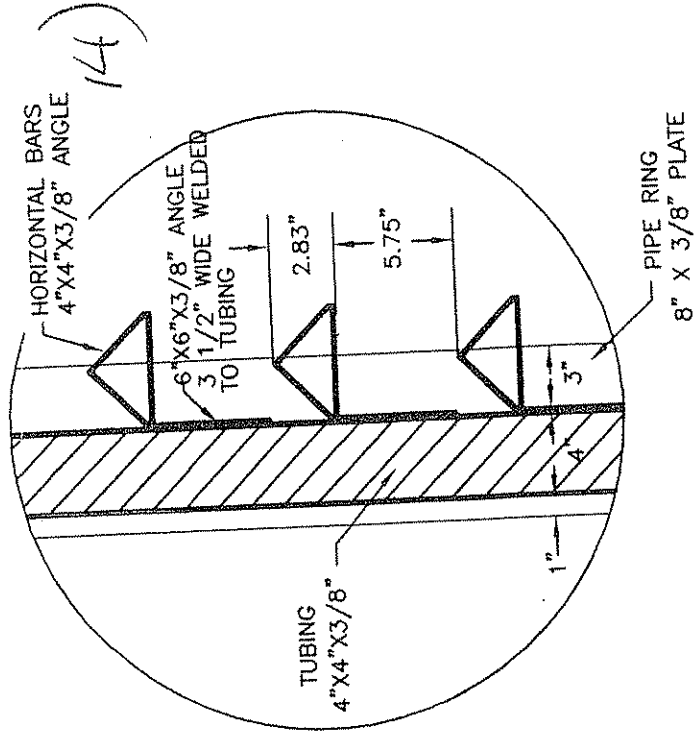

CMP ARCH CULVERT
 ES AND LENGTHS VARY)
 SEE PLAN

HORIZONTAL BAR DETAIL

PIPE RING SECTION
 (ALTERNATE)

TYPICAL DETAIL
PIPE BAT GATE

MANDATORY PRE-BID SIGN-IN ATTENDANCE SHEET

RFQ # : 14915 Bid Date: 5/6/10
 Project: PSNINSULA HW 1-2 Pre-Bid Date: 4/1/10

Name : Robert Barnes
 Company: BARNES EXC. INC
 Address: P.O. Box 13384
Slissonville WV 25360

Phone #: 304-984-1725
 Fax #: 304-984-0074
 Email : BarnesExc@aol.com

Name : HeFlin Contracting
 Company: John Oidaker
 Address: 1017 RIVER Rd
Clarksburg WV
26386

Phone #: 304 (623-5110)
 Fax #: 304 (623-0221)
 Email : John @ HeFlin Contracting
.com

Name : GEORGE FRESHOUR
 Company: EAGLE EXCAVATION INC
 Address: P.O. BOX 218
KENNA WV
25748

Phone #: (304) 372-4378
 Fax #: (304) 372-4378
 Email : George@freshour.com

Name : Don Vincent
 Company: Brea Kaway, Inc
 Address: 1075 Old Turnpike Rd.
Sutton, WV 26601

Phone #: 304-765-5317
 Fax #: 304-765-5389
 Email : BreaKaway-inc@verizon.net

Name : MAX ELLIOTT
 Company: JB & SONS LLC
 Address: 10643 BRANDONVILLE PIKE

Phone #: 304-329-0818
 Fax #: _____
 Email : bolinger5@verizon.net

Name : DAVID H. BOWMEIN
 Company: GREEN MOUNTAIN CO
 Address: 511 50th STREET
CHAS WV 25304

Phone #: 304 925 0253
 Fax #: 925 9230
 Email : Jody May @ AOL.com

Name : LES BOLEN
 Company: ASPEN CORP
 Address: 2400 RITTER DR
DANIELS WV 25832

Phone #: 304-763-4573
 Fax #: 304-763-4591
 Email : lbole@gaspengolf.com

Name : ALLEN MURDOCK
 Company: Borson Construction
 Address: P.O. Box 10 Procius
WV 25164

Phone #: 304 548-7004
 Fax #: 304 548-7133
 Email : borsonconst@yahoo.com

MANDATORY PRE-BID SIGN-IN ATTENDANCE SHEET

RFQ # : 14915
 Project: PENINSULA HW 102

Bid Date: 5/6/10
 Pre-Bid Date: 4/1/10

Name : GARY Long
 Company: M Court & Son Const
 Address: 2790 Centralia Rd
Sutton WV 26601
 Phone #: 304 765-5288
 Fax #: 304 765-5293
 Email : _____

Name : Donald Kennison
 Company: CHEAT LAKE Excavating
 Address: 41 Bruce Sliger Rd
MORGANTOWN, WV 26508
 Phone#: 304-594-1877
 Fax # : Same
 Email : _____

Name : Patrick Weimer
 Company: SCSL Co-Leasing Corp. Inc.
 Address: 8 Hunter Lane Rd
Fairmont WV
26554
 Phone #: 304-290-4608
 Fax #: 304-296-8252
 Email : jslavuta@yahoo.com

Name : Ed Baker
 Company: Baker Excavating
 Address: ~~P.O. 1163~~ P.O. 1163
Dellslow WV 26531
 Phone#: 304-282-1470
 Fax # : _____
 Email : _____

Name : JAMES ALLEN
 Company: JF ALLEN CO
 Address: PO Box 2049
Buckhannon WV
26201
 Phone #: 304 472 8890
 Fax #: 304 472 8897
 Email: JAMES.ALLEN@JFALLENCO.COM

Name : Mark Shepler
 Company: Cowgirl up
 Address: PO Box 243
Simpson WV
26435
 Phone#: 304 739 4397
 Fax # : 304-739-4401
 Email : _____

Name : JACOB MAPLE
 Company: Anderson Excavating
 Address: 343 Williams Rd
Morgantown WV 26501
 Phone #: 304-983-2296
 Fax #: 304-983-4755
 Email : randerson@andersonexcavatingllc.com

Name : _____
 Company: _____
 Address: _____
 Phone#: _____
 Fax # : _____
 Email : _____