



State of West Virginia
 Department of Administration
 Purchasing Division
 2019 Washington Street East
 Post Office Box 50130
 Charleston, WV 25305-0130

Request for Quotation

RFQ NUMBER
04100433

PAGE
1

ADDRESS CORRESPONDENCE TO ATTENTION OF
MICHAEL AUSTIN 304-558-2402

RFQ COPY
 TYPE NAME/ADDRESS HERE

VENDOR

SHIP TO

DIVISION OF HIGHWAYS
 DISTRICT FOUR
 P.O. BOX 4220
 CLARKSBURG, WV
 26302-2570 304-557-1550

DATE PRINTED	TERMS OF SALE	SHIP VIA	FOB	FREIGHT TERMS
03/01/2010				

BID OPENING DATE: 03/10/2010 BID OPENING TIME 01:30PM

LINE	QUANTITY	UOP	CAT NO	ITEM NUMBER	UNIT PRICE	AMOUNT
ADDENDUM NO. 2						
CHANGES TO THE DRAWINGS ATTACHED.						
PLAN SHEETS 5 & 6 HAVE BEEN REVISED TO ADD THE FIELD WELD SYMBOLS.						
BID OPENING DATE AND TIME CHANGED						
FROM: 03/03/10 @1:30 P.M.						
TO: 03/10/10 @1:30 P.M.						
NO OTHER CHANGES.						
0001	1	LS		760-69		
913 SF OF 2" TEE STEEL GRID SIDEWALK						
***** THIS IS THE END OF RFQ 04100433 ***** TOTAL:						

SEE REVERSE SIDE FOR TERMS AND CONDITIONS

SIGNATURE	TELEPHONE	DATE
TITLE	FEIN	ADDRESS CHANGES TO BE NOTED ABOVE

WHEN RESPONDING TO RFQ, INSERT NAME AND ADDRESS IN SPACE ABOVE LABELED 'VENDOR'

GENERAL TERMS & CONDITIONS REQUEST FOR QUOTATION (RFQ) AND REQUEST FOR PROPOSAL (RFP)

1. Awards will be made in the best interest of the State of West Virginia.
2. The State may accept or reject in part, or in whole, any bid.
3. Prior to any award, the apparent successful vendor must be properly registered with the Purchasing Division and have paid the required \$125 fee.
4. All services performed or goods delivered under State Purchase Order/Contracts are to be continued for the term of the Purchase Order/Contracts, contingent upon funds being appropriated by the Legislature or otherwise being made available. In the event funds are not appropriated or otherwise available for these services or goods this Purchase Order/Contract becomes void and of no effect after June 30.
5. Payment may only be made after the delivery and acceptance of goods or services.
6. Interest may be paid for late payment in accordance with the *West Virginia Code*.
7. Vendor preference will be granted upon written request in accordance with the *West Virginia Code*.
8. The State of West Virginia is exempt from federal and state taxes and will not pay or reimburse such taxes.
9. The Director of Purchasing may cancel any Purchase Order/Contract upon 30 days written notice to the seller.
10. The laws of the State of West Virginia and the *Legislative Rules* of the Purchasing Division shall govern the purchasing process.
11. Any reference to automatic renewal is hereby deleted. The Contract may be renewed only upon mutual written agreement of the parties.
12. **BANKRUPTCY:** In the event the vendor/contractor files for bankruptcy protection, the State may deem this contract null and void, and terminate such contract without further order.
13. **HIPAA BUSINESS ASSOCIATE ADDENDUM:** The West Virginia State Government HIPAA Business Associate Addendum (BAA), approved by the Attorney General, is available online at www.state.wv.us/admin/purchase/vrc/hipaa.htm and is hereby made part of the agreement. Provided that the Agency meets the definition of a Cover Entity (45 CFR §160.103) and will be disclosing Protected Health Information (45 CFR §160.103) to the vendor.
14. **CONFIDENTIALITY:** The vendor agrees that he or she will not disclose to anyone, directly or indirectly, any such personally identifiable information or other confidential information gained from the agency, unless the individual who is the subject of the information consents to the disclosure in writing or the disclosure is made pursuant to the agency's policies, procedures, and rules. Vendor further agrees to comply with the Confidentiality Policies and Information Security Accountability Requirements, set forth in <http://www.state.wv.us/admin/purchase/privacy/noticeConfidentiality.pdf>.
15. **LICENSING:** Vendors must be licensed and in good standing in accordance with any and all state and local laws and requirements by any state or local agency of West Virginia, including, but not limited to, the West Virginia Secretary of State's Office, the West Virginia Tax Department, and the West Virginia Insurance Commission. The vendor must provide all necessary releases to obtain information to enable the director or spending unit to verify that the vendor is licensed and in good standing with the above entities.
16. **ANTITRUST:** In submitting a bid to any agency for the State of West Virginia, the bidder offers and agrees that if the bid is accepted the bidder will convey, sell, assign or transfer to the State of West Virginia all rights, title and interest in and to all causes of action it may now or hereafter acquire under the antitrust laws of the United States and the State of West Virginia for price fixing and/or unreasonable restraints of trade relating to the particular commodities or services purchased or acquired by the State of West Virginia. Such assignment shall be made and become effective at the time the purchasing agency tenders the initial payment to the bidder.

I certify that this bid is made without prior understanding, agreement, or connection with any corporation, firm, limited liability company, partnership, or person or entity submitting a bid for the same material, supplies, equipment or services and is in all respects fair and without collusion or Fraud. I further certify that I am authorized to sign the certification on behalf of the bidder or this bid.

INSTRUCTIONS TO BIDDERS

1. Use the quotation forms provided by the Purchasing Division. Complete all sections of the quotation form.
2. Items offered must be in compliance with the specifications. Any deviation from the specifications must be clearly indicated by the bidder. Alternates offered by the bidder as **EQUAL** to the specifications must be clearly defined. A bidder offering an alternate should attach complete specifications and literature to the bid. The Purchasing Division may waive minor deviations to specifications.
3. Unit prices shall prevail in case of discrepancy. All quotations are considered F.O.B. destination unless alternate shipping terms are clearly identified in the quotation.
4. All quotations must be delivered by the bidder to the office listed below prior to the date and time of the bid opening. Failure of the bidder to deliver the quotations on time will result in bid disqualifications: Department of Administration, Purchasing Division, 2019 Washington Street East, P.O. Box 50130, Charleston, WV 25305-0130
5. Communication during the solicitation, bid, evaluation or award periods, except through the Purchasing Division, is strictly prohibited (W.Va. C.S.R. §148-1-6.6).

NO. 2	NO. 1	NO. 2	NO. 3	NO. 4	NO. 5	NO. 6	NO. 7	NO. 8	NO. 9	NO. 10
REV.	DATE	BY	CHKD.	APP'D.	DATE	BY	CHKD.	APP'D.	DATE	BY
1	12/08	ALL								
2	12/09	ALL								

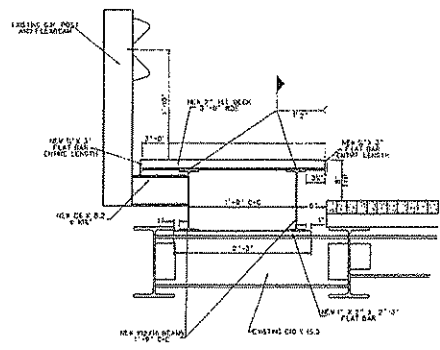
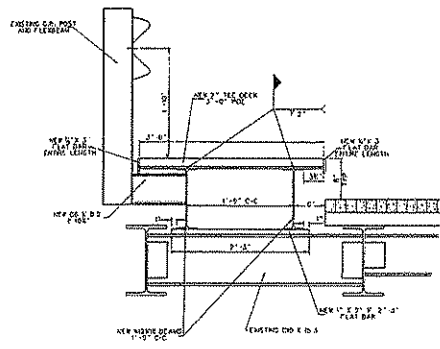
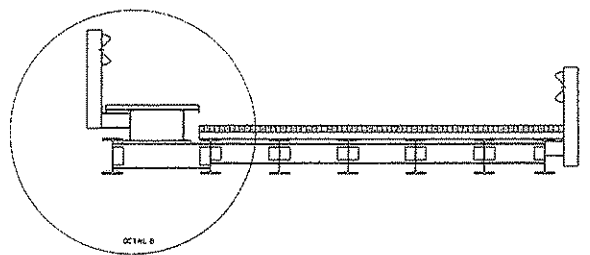
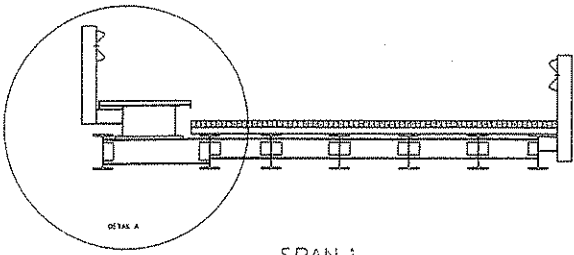

DETAIL A

DETAIL B

NOTE: ALL CROSS SECTION VIEWS ARE LOOKING FORWARD
ALL BEAMS, PLATES, AND TEE DECK ARE WELDED

DESIGNED BY	12/08	J. S.	ADRIAN WEAVER ENGINEERS	01/20/09	J.L.	THE WEST VIRGINIA DEPARTMENT OF TRANSPORTATION
CHECKED BY						DIVISION OF HIGHWAYS
APPROVED BY	12/08	ALL				DISTRICT FOUR BRIDGE DEPARTMENT
DESIGNED BY	12/09	ALL				HUTCHINSON TRUSS BRIDGE
			REVISION	DATE	BY	PROPOSED CROSS SECTION
						VIEW'S SPAN 1 AND 4
						DRWING NO. 6822.2

12/15/09 12:47:27 PM 12/15/09 12:47:27 PM

Sheet No.	4	State Project No.	SS25-80/3-0.03	Fiscal Year	2010	County	MARSH	Sheet Total	6	Sheet No.	8
-----------	---	-------------------	----------------	-------------	------	--------	-------	-------------	---	-----------	---

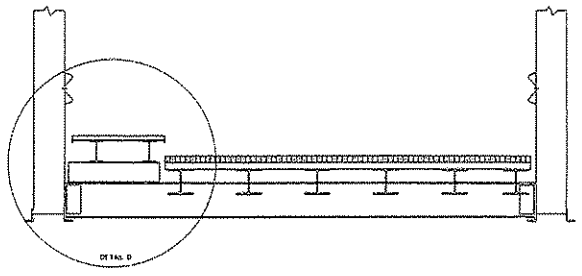
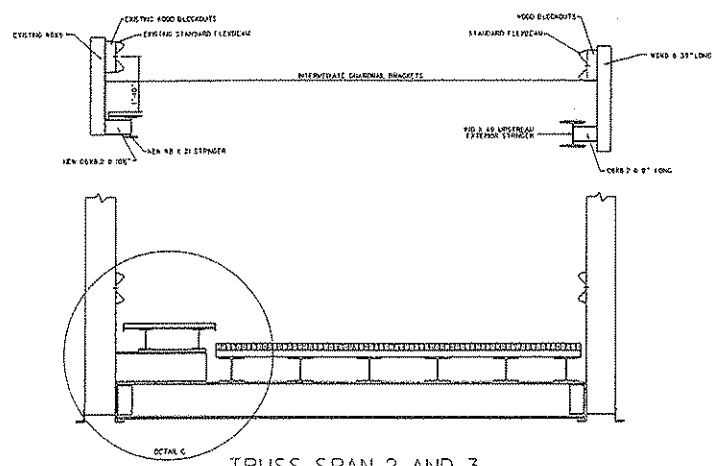

TRUSS SPAN 2 AND 3

TRUSS @ L1 AND L11

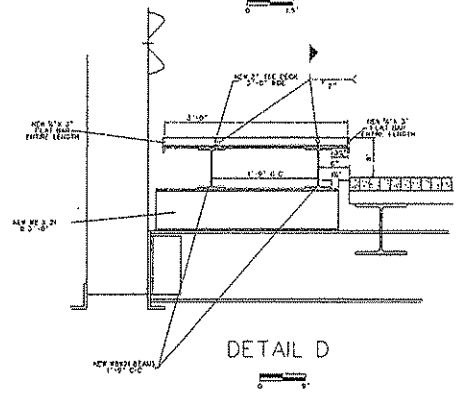
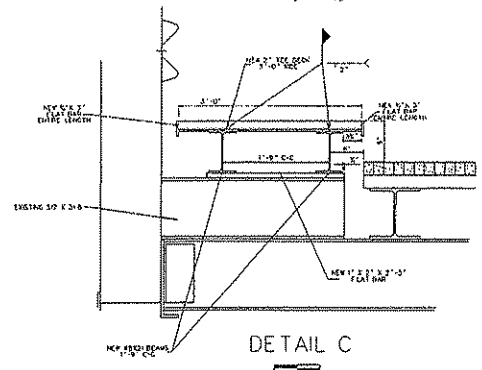

NOTE: ALL CROSS SECTION VIEWS ARE LOOKING FORWARD
ALL BEAMS, PLATES, AND TEE DECK ARE WELDED.

DESIGNED BY:	ALS	DATE:	12/09	REVISION:		DATE:		BY:		THE WEST VIRGINIA DEPARTMENT OF TRANSPORTATION
CHECKED BY:	ALL	DATE:	12/09	REVISION:		DATE:		BY:		DIVISION OF HIGHWAYS
APPROVED BY:	ALL	DATE:	12/09	REVISION:		DATE:		BY:		DISTRICT FOUR BRIDGE DEPARTMENT
										HUTCHINSON TRUSS BRIDGE
										PROPOSED CROSS SECTION
										VIEWS SPAN 2 AND 3
										SHEET 6 OF 8
										REVISION NO. 0002.2

12/15/2009 10:42 AM
 C:\pwworkspace\hutchinson_truss_bridge\hutchinson_truss_bridge.dwg
 PLOTTER: