



State of West Virginia
 Department of Administration
 Purchasing Division
 2019 Washington Street East
 Post Office Box 50130
 Charleston, WV 25305-0130

Request for Quotation

RFQ NUMBER
EDD310043

PAGE
1

ADDRESS CORRESPONDENCE TO ATTENTION OF:
SHELLY MURRAY 304-558-8801

VENDOR

RFQ COPY
 TYPE NAME/ADDRESS HERE

SHIP TO

DEPARTMENT OF EDUCATION
 BUILDING 6
 1900 KANAWHA BOULEVARD, EAST
 CHARLESTON, WV
 25305-0330

DATE PRINTED	TERMS OF SALE	SHIP VIA	F.O.B.	FREIGHT TERMS
02/24/2009				

BID OPENING DATE: 03/11/2009 BID OPENING TIME: 01:30PM

LINE	QUANTITY	UOP	CAT. NO.	ITEM NUMBER	UNIT PRICE	AMOUNT
----- ADDENDUM NO. 3 ----- THIS ADDENDUM IS ISSUED TO ADDRESS THE QUESTIONS RAISE PRIOR TO THE QUESTION SUBMISSION DEADLINE OF 2/10/2009. THE BID OPENING DATE IS EXTENDED: FROM: 2/25/2009 TO : 3/11/2009 THE ATTACHED DRUG FREE WORKPLACE CONFORMANCE AFFIDAVIT MUST BE SUBMITTED WITH THE VENDOR'S BID. ----- END OF ADDENDUM NO. 3 -----						
0001	1	LS		968-42		
HAVING CONSTRUCTION						

SEE REVERSE SIDE FOR TERMS AND CONDITIONS

SIGNATURE	TELEPHONE	DATE
-----------	-----------	------

TITLE	FEIN	ADDRESS CHANGES TO BE NOTED ABOVE
-------	------	-----------------------------------

WHEN RESPONDING TO RFQ, INSERT NAME AND ADDRESS IN SPACE ABOVE LABELED 'VENDOR'

**GENERAL TERMS & CONDITIONS
REQUEST FOR QUOTATION (RFQ) AND REQUEST FOR PROPOSAL (RFP)**

1. Awards will be made in the best interest of the State of West Virginia.
2. The State may accept or reject in part, or in whole, any bid.
3. All quotations are governed by the *West Virginia Code* and the *Legislative Rules* of the Purchasing Division.
4. Prior to any award, the apparent successful vendor must be properly registered with the Purchasing Division and have paid the required \$125 fee.
5. All services performed or goods delivered under State Purchase Order/Contracts are to be continued for the term of the Purchase Order/Contracts, contingent upon funds being appropriated by the Legislature or otherwise being made available. In the event funds are not appropriated or otherwise available for these services or goods, this Purchase Order/Contract becomes void and of no effect after June 30.
6. Payment may only be made after the delivery and acceptance of goods or services.
7. Interest may be paid for late payment in accordance with the *West Virginia Code*.
8. Vendor preference will be granted upon written request in accordance with the *West Virginia Code*.
9. The State of West Virginia is exempt from federal and state taxes and will not pay or reimburse such taxes.
10. The Director of Purchasing may cancel any Purchase Order/Contract upon 30 days written notice to the seller.
11. The laws of the State of West Virginia and the *Legislative Rules* of the Purchasing Division shall govern all rights and duties under the Contract, including without limitation the validity of this Purchase Order/Contract.
12. Any reference to automatic renewal is hereby deleted. The Contract may be renewed only upon mutual written agreement of the parties.
13. **BANKRUPTCY:** In the event the vendor/contractor files for bankruptcy protection, this Contract may be deemed null and void, and terminated without further order.
14. **HIPAA BUSINESS ASSOCIATE ADDENDUM:** The West Virginia State Government HIPAA Business Associate Addendum (BAA), approved by the Attorney General, and available online at the Purchasing Division's web site (<http://www.state.wv.us/admin/purchase/vrc/hipaa.htm>) is hereby made part of the agreement. Provided that, the Agency meets the definition of a Cover Entity (45 CFR §160.103) and will be disclosing Protected Health Information (45 CFR §160.103) to the vendor.
15. **WEST VIRGINIA ALCOHOL & DRUG-FREE WORKPLACE ACT:** If this Contract constitutes a public improvement construction contract as set forth in Article 1D, Chapter 21 of the West Virginia Code ("The West Virginia Alcohol and Drug-Free Workplace Act"), then the following language shall hereby become part of this Contract: "The contractor and its subcontractors shall implement and maintain a written drug-free workplace policy in compliance with the West Virginia Alcohol and Drug-Free Workplace Act, as set forth in Article 1D, Chapter 21 of the West Virginia Code. The contractor and its subcontractors shall provide a sworn statement in writing, under the penalties of perjury, that they maintain a valid drug-free work place policy in compliance with the West Virginia and Drug-Free Workplace Act. It is understood and agreed that this Contract shall be cancelled by the awarding authority if the Contractor: 1) Fails to implement its drug-free workplace policy; 2) Fails to provide information regarding implementation of the contractor's drug-free workplace policy at the request of the public authority; or 3) Provides to the public authority false information regarding the contractor's drug-free workplace policy."

INSTRUCTIONS TO BIDDERS

1. Use the quotation forms provided by the Purchasing Division.
2. **SPECIFICATIONS:** Items offered must be in compliance with the specifications. Any deviation from the specifications must be clearly indicated by the bidder. Alternates offered by the bidder as **EQUAL** to the specifications must be clearly defined. A bidder offering an alternate should attach complete specifications and literature to the bid. The Purchasing Division may waive minor deviations to specifications.
3. Complete all sections of the quotation form.
4. Unit prices shall prevail in case of discrepancy.
5. All quotations are considered F.O.B. destination unless alternate shipping terms are clearly identified in the quotation.
6. **BID SUBMISSION:** All quotations must be delivered by the bidder to the office listed below prior to the date and time of the bid opening. Failure of the bidder to deliver the quotations on time will result in bid disqualifications: Department of Administration, Purchasing Division, 2019 Washington Street East, P.O. Box 50130, Charleston, WV 25305-0130

EDD310043
ADDENDUM NO. 3

- 1. What are the options for waste material disposal?**
The Cedar Lakes facility has need for fill on-site. Permissible fill/waste materials may be dumped on-site at the location designated by camp management. When feasible, it is preferred that the materials be separated by type (i.e. dirt and gravel separated from asphalt/concrete).
- 2. Was a "base coat" required in the project specifications as a barrier below the asphalt?**
References to a "base coat", if any, should be removed from the project specifications. This process has been deemed to be an outdated technology. The specifications relating to a "prime coat" in the specifications are still applicable.
- 3. What were the project specifications relating to the use of herbicides?**
Please see the attached architect's documents, specifically item #5.B.
- 4. What is the expected method of transition to the existing curb and gutter, particularly as shown in the architect's drawings as alternate 1?**
Please see the attached architect's documents, specifically item #3.A.
- 5. What are the recommendations for the transition of pavement to the sidewalk along the northern side of the main loop in the area adjacent to the 2nd alternate, as shown in the architect's drawings? This problem is caused by different sections of sidewalk possessing inconsistent elevations.**
Please see the attached architect's documents, specifically item #1.A and #1.B.
- 6. What is the expected length of the curb to be replaced (see keyed note #9 in alternate #3)?**
Please see the attached architect's documents, specifically item #4.A.
- 7. In relation to the detail of 2/SD-7, where shall the transition to the curb height begin/end?**
Please see the attached architect's documents, specifically item #5.A.
- 8. Is the weight limit known on the bridge?**
The weight limit is unknown.
- 9. Upon the discovery of holes in the bridge decking, what will be the responsibility of the successful vendor?**
Please see the attached architect's documents, specifically item #2.A.

- 10. What fabric is specified in the rip-rap ditch? Is Mariqi-550 suitable?**
See specification section 01330 Submittal Procedures for the product submittal process.
- 11. Need list of approved herbicides.**
See specification section 01330 Submittal Procedures for the product submittal process.
- 12. In "New Paving Areas" is total excavation required?**
Yes, see general note 9 on drawing SD-1 of the original construction documents.
- 13. Ref: Rip-rap ditch – Is any of the ditch existing or is total excavation required?**
Excavation is required to install new rip-rap ditch.
- 14. Is the entrance bridge the only area to be milled?**
No. Other areas will need to be milled to meet existing sidewalks, curbs, aprons and parking lot elevations.
- 15. Is all the overlay on the "ring road" in the base bid?**
The base bid is identified in general note 8 Drawing SD-1 of the original construction documents.
- 16. Do we have to excavate the areas of new paving?**
Yes. See general note 9 on Drawing SD-1 of the original construction documents.
- 17. Prime coat removed—see attachment.**
See response to question #2 above.



RECEIVED

2009 FEB 23 PM 3:30

February 17, 2009

WV PURCHASING
DIVISION **ADDENDUM NO. 3**

RE: Phase Three Road Paving Project
Cedar Lakes Conference Center
Ripley, West Virginia
Architect's Project No. 0614

TO: Prospective Bidders

FROM: ZMM, Inc. Architects And Engineers

This Addendum forms a part of the Contract Documents and modifies the original Bidding Documents.

**ATTACH THIS ADDENDUM TO THE FRONT COVER OF THE PROJECT MANUAL AND
ACKNOWLEDGE RECEIPT OF THIS ADDENDUM IN THE SPACE PROVIDED ON THE BID FORM.**

See Addendum No. 3 for the captioned project with State RFQ No. EDD310043 as issued by the State Of West Virginia Department Of Administration Purchasing Division as attached.

CHANGES TO DRAWINGS:

1. Drawing No. SD1 – Make the following Revisions:
 - A. Add Note to sidewalk in front of Lions Cottage to read: "Cold plane a six foot wide portion of existing road adjacent to existing sidewalk and curb to allow new overlayment to match elevation of existing pavement where it meets the curb. This will include full length of sidewalk (Approximately 650 Lineal Feet)."
 - B. Change Scale of Drawing from 1 inch = 60 feet 0 inches to 1 inch = 100 feet 0 inches.
2. Drawing No. SD2 – Make the following Revisions:
 - A. ADD to Keyed Note No. 8 the following: " Contractor will, to the best of his ability, keep debris from falling into Mill Creek through existing holes in bridge deck. Contractor will, prior to paving, install wood plugs in existing 2 inch holes in bridge deck.
3. Drawing No. SD3 – Make the following Revisions:
 - A. ADD to Keyed Note No. 3 the following: " Extend wearing layer of asphalt paving over top of existing concrete gutter to edge of curb."



4. Drawing No. SD5 – Make the following Revisions:
 - A. REVISE Keyed Note No. 9 as follows: REPLACE the wording “Approximately 10 feet of concrete curb to be repaired” with “Approximately 25 feet of concrete curb to be replaced.”
 - B. ADD note to curb gutter in front of VFW cottage to read: “Install new drop inlet at existing 8 inch storm sewer line.” See attached detail drawing dated October 13, 2008 with Inlet Box Detail and Plan View Gutter Inlet.

5. Drawing No. SD7 – Make the following Revisions:
 - A. ADD note to Asphalt Ramp detail No. 2 to read: “Transition of asphalt paving at top of existing curb may start at interior side of existing support columns adjacent to office building.”
 - B. ADD note to Rip-Rap Ditch Detail No. 5 to read: “Herbicide Treatment to be limited to Rip-Rap Ditch Only”.

Attachments: Detail Drawing dated October 13, 2008

End Of Addendum

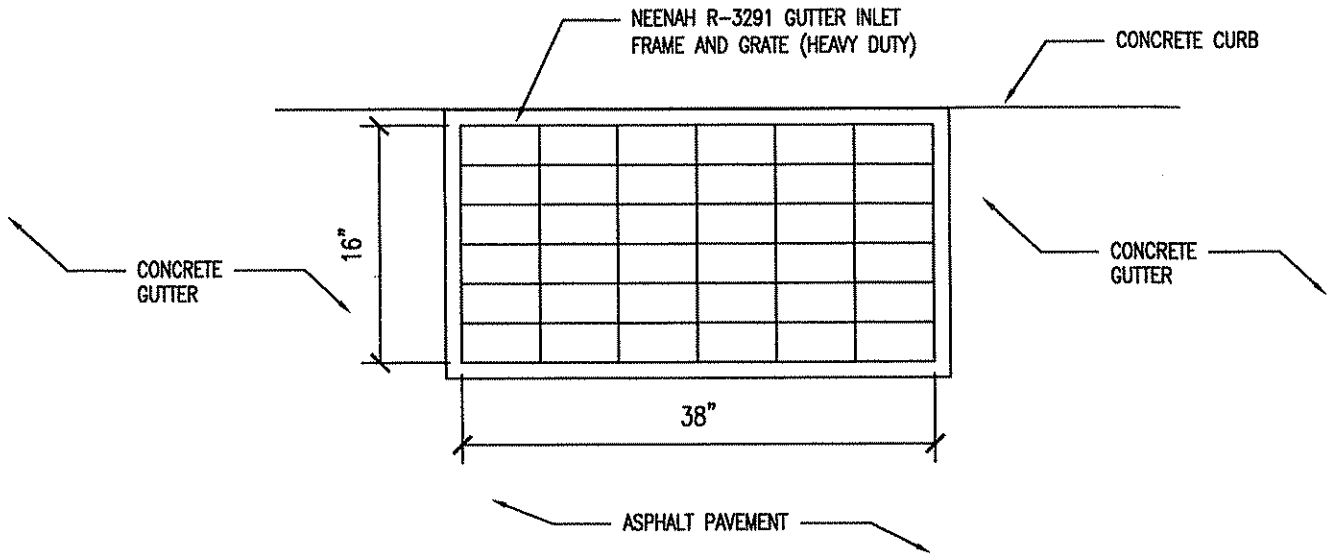

PLAN VIEW GUTTER INLET
SCALE: NTS

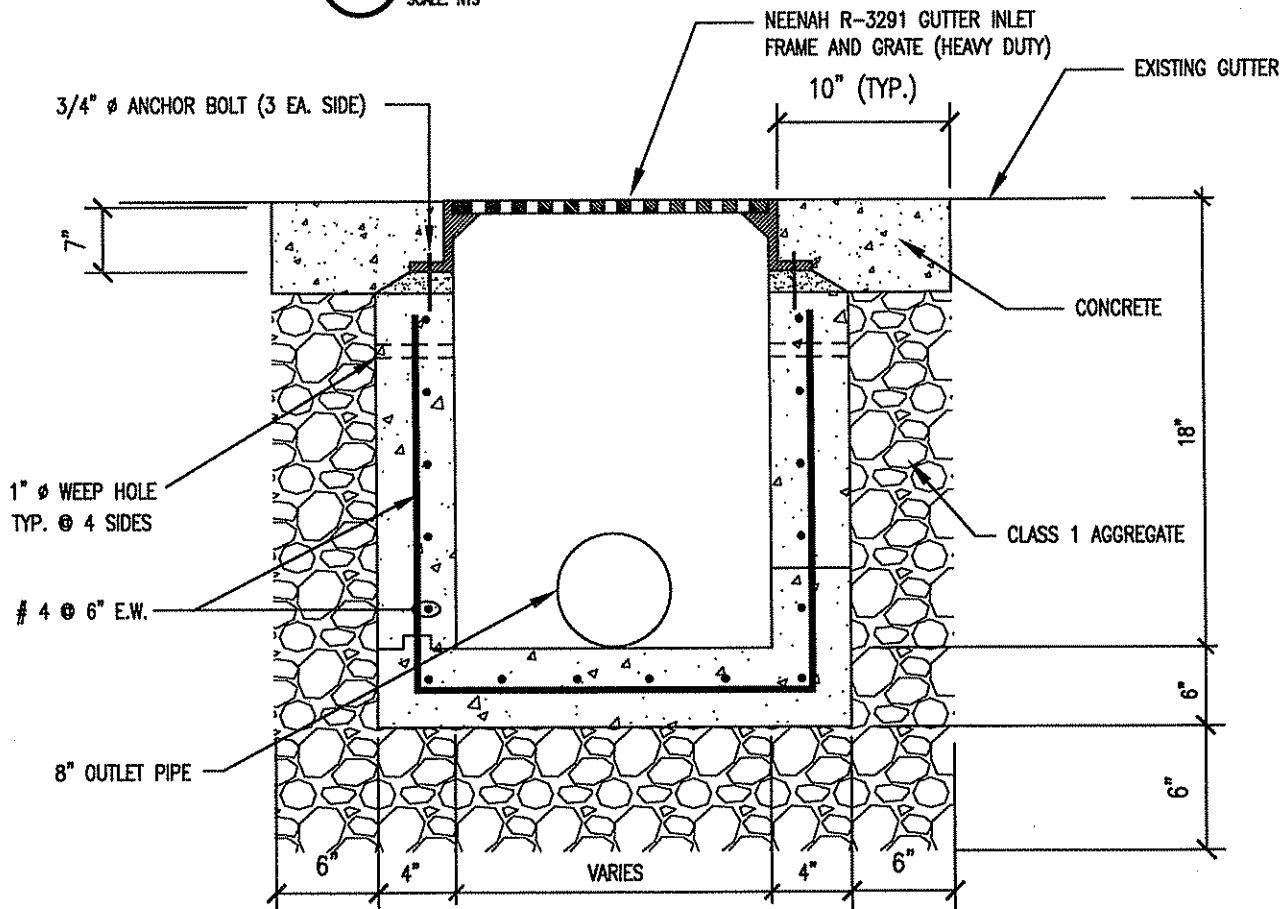

NOTE: OUTLET PIPE INVERT AND BOX INVERT SHALL MATCH.

INLET BOX DETAIL
SCALE: NTS

ZMM
ZMM, INC.
ARCHITECTS / ENGINEERS
200 LANE STREET W
CHARLESTON, WV 26030
PHONE (800) 948-0800
FAX (800) 948-0800



**State of West Virginia
DRUG FREE WORKPLACE CONFORMANCE AFFIDAVIT
West Virginia Code §21-1D-5**

STATE OF WEST VIRGINIA,

COUNTY OF _____, TO-WIT:

I, _____, after being first duly sworn, depose and state as follows:

- 1. I am an employee of _____; and,
(Company Name)
- 2. I do hereby attest that _____
(Company Name)

maintains a valid written drug free workplace policy and that such policy is in compliance with **West Virginia Code §21-1D-5**.

The above statements are sworn to under the penalty of perjury.

(Company Name)

By: _____

Title: _____

Date: _____

Taken, subscribed and sworn to before me this _____ day of _____.

By Commission expires _____

(Seal)

(Notary Public)

THIS AFFIDAVIT MUST BE SUBMITTED WITH THE BID IN ORDER TO COMPLY WITH WV CODE PROVISIONS. FAILURE TO INCLUDE THE AFFIDAVIT WITH THE BID SHALL RESULT IN DISQUALIFICATION OF THE BID.