



State of West Virginia
 Department of Administration
 Purchasing Division
 2019 Washington Street East
 Post Office Box 50130
 Charleston, WV 25305-0130

Request for Quotation

RFQ NUMBER
DNR209115

PAGE
1

ADDRESS CORRESPONDENCE TO ATTENTION OF:
**FRANK WHITTAKER
 304-558-2316**

RFQ COPY
 TYPE NAME/ADDRESS HERE

VENDOR

SHIP TO

DIVISION OF NATURAL RESOURCES
 BERWIND LAKE WMA
 ATTN: PARK SUPERINTENDENT
 POST OFFICE BOX 38
 WARRIORMINE, WV
 24894 875-4663

DATE PRINTED	TERMS OF SALE	SHIP VIA	F.O.B.	FREIGHT TERMS
04/09/2009				

BID OPENING DATE: **05/07/2009** BID OPENING TIME **01:30PM**

LINE	QUANTITY	UOP	CAT NO	ITEM NUMBER	UNIT PRICE	AMOUNT
0001	1	LS		650-38		
<p>PLAYGROUND EQUIPMENT (NOT OTHERWISE CLASSIFIED)</p> <p>THE WEST VIRGINIA PURCHASING DIVISION, FOR THE AGENCY, THE WEST VIRGINIA DIVISION OF NATURAL RESOURCES IS SOLICITING BIDS FOR PLAYGROUND EQUIPMENT FOR BERWIND LAKE WMA.</p> <p>A MANDATORY PRE-BID CONFERENCE WILL BE HELD ON 04/22/09 AT 1:00 PM AT BERWIND LAKE WMA HEADQUARTERS. FAILURE TO ATTEND THE MANATORY PRE-BID MEETING WILL RESULT IN BID DISQUALIFICATION. AN INDIVIDUAL MAY NOT REPRESENT MORE THAN ONE FIRM AT THE MEETING.</p> <p>TECHNICAL QUESTIONS MAY BE SUBMITTED IN WRITING TO FRANK WHITTAKER IN THE PURCHASING DIVISION VIA FAX AT 304-558-4115 OR VIA EMAIL AT FRANK.M.WHITTAKER@WV.GOV DEADLINE FOR TECHNICAL QUESTIONS IS 04/27/09 AT 4:00 PM ALL TECHNICAL QUESTIONS WILL BE ANSWERED BY ADDENDUM AFTER THE DEADLINE.</p> <p>BANKRUPTCY: IN THE EVENT THE VENDOR/CONTRACTOR FILES FOR BANKRUPTCY PROTECTION, THIS CONTRACT MAY BE DEEMED NULL AND VOID, AND TERMINATED WITHOUT FURTHER ORDER.</p> <p>THE MODEL/BRAND/SPECIFICATIONS NAMED HEREIN ESTABLISH THE ACCEPTABLE LEVEL OF QUALITY ONLY AND ARE NOT INTENDED TO REFLECT A PREFERENCE OR FAVOR ANY PARTICULAR BRAND OR VENDOR. VENDORS WHO ARE BIDDING ALTERNATES SHOULD SO STATE AND INCLUDE PERTINENT LITERATURE AND SPECIFICATIONS. FAILURE TO PROVIDE</p>						

SEE REVERSE SIDE FOR TERMS AND CONDITIONS

SIGNATURE	TELEPHONE	DATE
TITLE	FEIN	ADDRESS CHANGES TO BE NOTED ABOVE

WHEN RESPONDING TO RFQ, INSERT NAME AND ADDRESS IN SPACE ABOVE LABELED 'VENDOR'



State of West Virginia
 Department of Administration
 Purchasing Division
 2019 Washington Street East
 Post Office Box 50130
 Charleston, WV 25305-0130

Request for Quotation

RFQ NUMBER
DNR209115

PAGE
2

ADDRESS CORRESPONDENCE TO ATTENTION OF:
FRANK WHITTAKER 304-558-2316

RFQ COPY
 TYPE NAME/ADDRESS HERE

VENDOR

SHIP TO

DIVISION OF NATURAL RESOURCES
 BERWIND LAKE WMA
 ATTN: PARK SUPERINTENDENT
 POST OFFICE BOX 38
 WARRIORMINE, WV
 24894 875-4663

DATE PRINTED	TERMS OF SALE	SHIP VIA	F.O.B.	FREIGHT TERMS
04/09/2009				

BID OPENING DATE: **05/07/2009** BID OPENING TIME **01:30PM**

LINE	QUANTITY	UOP	CAT NO	ITEM NUMBER	UNIT PRICE	AMOUNT
<p>INFORMATION FOR ANY ALTERNATES MAY BE GROUNDS FOR REJECTION OF THE BID. THE STATE RESERVES THE RIGHT TO WAIVE MINOR IRREGULARITIES IN BIDS OR SPECIFICATIONS IN ACCORDANCE WITH SECTION 148-1-4(F) OF THE WEST VIRGINIA LEGISLATIVE RULES AND REGULATIONS.</p> <p style="text-align: center;">NOTICE</p> <p>A SIGNED BID MUST BE SUBMITTED TO:</p> <p style="padding-left: 40px;">DEPARTMENT OF ADMINISTRATION PURCHASING DIVISION BUILDING 15 2019 WASHINGTON STREET, EAST CHARLESTON, WV 25305-0130</p> <p>THE BID SHOULD CONTAIN THIS INFORMATION ON THE FACE OF THE ENVELOPE OR THE BID MAY NOT BE CONSIDERED:</p> <p>SEALED BID</p> <p>BUYER: 44</p> <p>RFQ. NO.: DNR209115</p> <p>BID OPENING DATE: 05/07/09</p> <p>BID OPENING TIME: 1:30 PM</p> <p>PLEASE PROVIDE A FAX NUMBER IN CASE IT IS NECESSARY TO CONTACT YOU REGARDING YOUR BID:</p>						

SEE REVERSE SIDE FOR TERMS AND CONDITIONS

SIGNATURE	TELEPHONE	DATE
TITLE	FEIN	ADDRESS CHANGES TO BE NOTED ABOVE

WHEN RESPONDING TO RFQ, INSERT NAME AND ADDRESS IN SPACE ABOVE LABELED 'VENDOR'



State of West Virginia
 Department of Administration
 Purchasing Division
 2019 Washington Street East
 Post Office Box 50130
 Charleston, WV 25305-0130

Request for Quotation

RFQ NUMBER
DNR209115

PAGE
3

ADDRESS CORRESPONDENCE TO ATTENTION OF:
FRANK WHITTAKER
304-558-2316

VENDOR

RFQ COPY
 TYPE NAME/ADDRESS HERE

SHIP TO

DIVISION OF NATURAL RESOURCES
BERWIND LAKE WMA
ATTN: PARK SUPERINTENDENT
POST OFFICE BOX 38
WARRIORMINE, WV
24894 875-4663

DATE PRINTED	TERMS OF SALE	SHIP VIA	F.O.B.	FREIGHT TERMS
04/09/2009				

BID OPENING DATE: **05/07/2009** BID OPENING TIME **01:30PM**

LINE	QUANTITY	UOP	CAT NO	ITEM NUMBER	UNIT PRICE	AMOUNT

CONTACT PERSON (PLEASE PRINT CLEARLY):						

***** THIS IS THE END OF RFQ DNR209115 ***** TOTAL: _____						

SEE REVERSE SIDE FOR TERMS AND CONDITIONS

SIGNATURE		TELEPHONE		DATE
TITLE	FEIN	ADDRESS CHANGES TO BE NOTED ABOVE		

WHEN RESPONDING TO RFQ, INSERT NAME AND ADDRESS IN SPACE ABOVE LABELED 'VENDOR'

**Berwind Lake Wildlife Management Area
Playground Specifications**

To supply playground equipment to offer play activities for children ages two (2) to twelve (12) at Berwind Lake Wildlife Management Area, Warriormine West Virginia. Playground equipment will be purchased for three (3) separate areas in the park. Park personnel will install all playground equipment. The award may be split if it is in the best interest of the West Virginia Division of Natural Resources. All items must be F.O.B. Destination. Freight or delivery charges must be included in the price of the goods. Delivery must be made within ninety (90) days of purchase order award.

POOL AREA PLAYGROUND

Miracle tarantula climber, Model #4561, or equal. Climber must have a horizontal top ring of two rails with rungs; have four vertical support legs attached to the ring's inner rail; and have four vertical climber ladder assemblies attached to the ring's outer rail.

Miracle, 630° typhoon slide, Model #65759, or equal. Slide must be freestanding with a spiral one-piece open bed-way; have an enclosed platform a minimum of 9'4" in height; and have pvc-coated steel steps with handrails.

Miracle chipper squirrel "C" spring rider model #918, or equal. Rider must be freestanding and must allow for a traditional rocking horse type movement utilizing a flat strip style spring that has been formed into a "C" shape. Rider must have a footrest with an aluminum enamel finish and footrest caps with nickel chrome and the finish mounting frame must have a galvanized finish

Miracle pokey the snail "C" spring rider, Model #963, or equal. Rider must be freestanding and must allow for a traditional rocking horse type movement utilizing a flat strip style spring that has been formed into a "C" shape. Rider must have a footrest with an aluminum enamel finish and footrest caps with nickel chrome and the finish mounting frame must have a galvanized finish.

Miracle 5" OD arch tire swing complete model #714852, or equal. Swing frame must have two end arches; have a header; have clamps which assemble to form a swing frame; have swivel and tire assemblies attached to the frame by pvc-coated chains. Arch assembly must be constructed of a minimum of 5" tube; and tire assembly must swing to and fro and must rotate 360°.

Miracle 5" OD arch 2 bay swing frame 4 seats REQ MC, Model #7148524, or equal. Frame must have two end arches and one center arch; have an OD top rail to form a 2-bay swing frame; be constructed of a minimum of 5" tube.

**Berwind Lake Wildlife Management Area
Playground Specifications**

Miracle the whirl (merry-go-round), Model #303, or equal. Whirl must have four u-shaped handrails atop a deck assembly that spins on a center hub; and have a speed governing device that is concealed and activated by centrifugal force.

ENTRANCE AREA PLAYGROUND

Miracle, peak climber, Model #4582a2, or equal. Freestanding climber must have a center post and ground-mounted inclined rails that contain a series of welded "U" loops on undersides.

Miracle 405° typhoon slide, Model #65749, or equal. Slide must be freestanding with a spiral one-piece open bed way; have an enclosed platform a minimum of 6' 3" in height; and have pvc coated steel steps with handrails.

Miracle twin rider, Model #6081, or equal. Rider must accommodate two children; have twin coin springs for four way rock and teeter; have a steel frame with aluminum seats; have a steel hand and floor rest; and have a Perma-guard finish. Each spring must have two spirals lock plates for attachment to the support arm and mounting frame.

OFFICE AREA PLAYGROUND

Miracle swing part slash proof seat with clevis, Model #284, or equal. Seat must be a flexible flat single strap with end attachment points and have a galvanized steel clip a minimum of 3" wide triangle at end of each seat.

Miracle swing part tot seat 360° with clevis model #299, or equal. Seat must be flexible and fabricated into a configuration of a wide strap under and through the bottom, a wide strap around the top and have two interconnecting straps at the front and rear of the seat for complete enclosure of a small child.

Miracle OD arch one bay swing frame with two (2) s/p seats MC, Model #7148522s, or equal. Swing frame must have two end arches with OD top rail to form a single bay swing frame; and frame must be constructed of a minimum of 5" tube.

ITEMS FOR ALL THREE PLAYGROUNDS

Engineered wood fiber or equal. Material must be recently harvested and debarked; free of chemical treatments and additives; free of soil, twigs, leaves and other contaminants.

**Berwind Lake Wildlife Management Area
Playground Specifications**

All playground equipment and engineered wood fiber must meet the following requirements:

- Compliance with U.S. Consumer Product Safety Commission, Handbook for Public Playground Safety.
- Compliance with ASTM Standard F 1487.
- Compliance with Architectural and Transportation Barriers Compliance Board, Americans with Disabilities Act (ADA) Accessibility Guidelines for Buildings and Facilities; Play Areas.

Vendors must submit the following attachments:

- Complete manufacturer's parts specifications and warranties.
- Layout drawing to scale of the proposed play structure or equipment.
- ASTM and CPSC Statement of Compliance

Warranties:

- All equipment and engineered wood fiber must be guaranteed to be free of defects in workmanship and material for a minimum of one year from date of acceptance. However, if manufacturer warranty periods are longer than the required minimum one year warranty, those warranties shall apply.

All playground equipment must include tamper proof fasteners to prevent theft and destruction.

Color scheme of equipment must be coordinated with Berwind Lake Wildlife Management Area. Color of items will be selected from manufacturer's standard colors.

A mandatory pre-bid conference will be held on April ?, 2009, at Berwind Lake Wildlife Management Area Headquarters at ?. A failure to attend the mandatory pre-bid conference will result in bid disqualification. An individual may not represent more than one firm at the pre-bid conference.



Product Specifications

Dec. 19, 2002 Rev. A

MIRACLE
RECREATION EQUIPMENT COMPANY

Tarantula Climber

456-1

Tarantula Climber

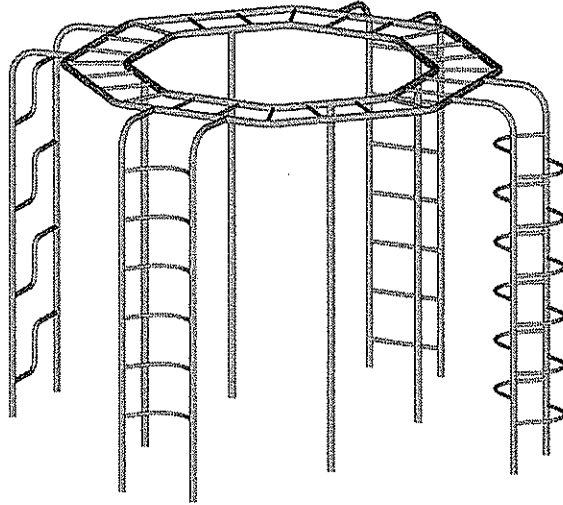

Tarantula Climber

456-1



Product Specifications

MIRACLE
RECREATION EQUIPMENT COMPANY

Freestanding Typhoon Slides - Platform Heights of 6'-3", 9'-4" & 12'

Freestanding Typhoon Slides

65-748 and 65-749

Freestanding Typhoon Slide, 360°, 6'-3" Platform

Freestanding Typhoon Slide, 405°, 6'-3" Platform

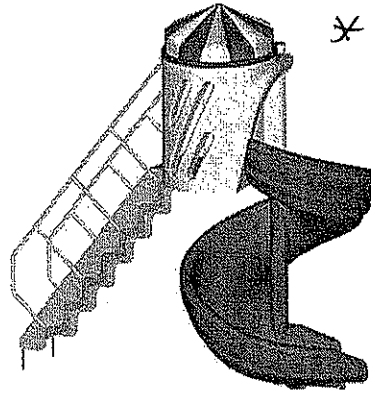
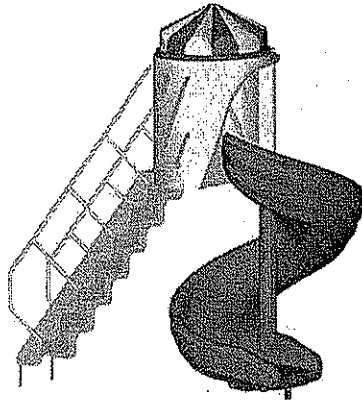

65-759 and 65-769

Freestanding Typhoon Slide, 630°, 9'-4" Platform

Freestanding Typhoon Slide, 855°, 12' Platform

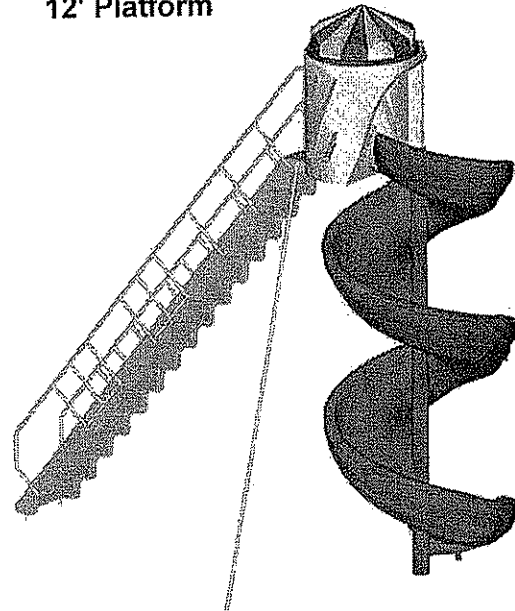
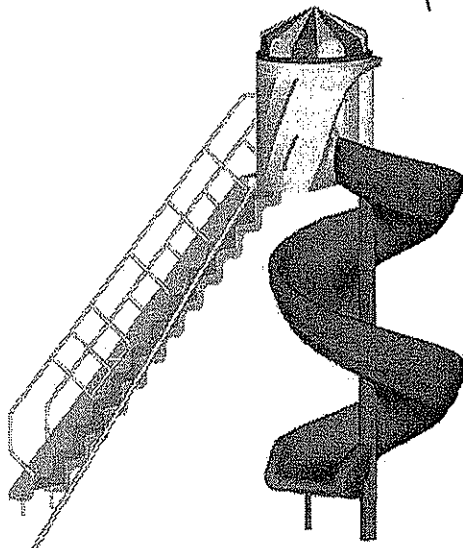



Product Specifications

MIRACLE
RECREATION EQUIPMENT COMPANY

"C" Spring Riders - Rodeo Rocky, Cleo Lion, Chipper Squirrel, Sammy Seal, Moto-Cross, Frog, Schnozz Wump, Elephant, Jet Interceptor & ATV

901

"Rodeo Rocky" "C" Spring Rider



917

"Cleo Lion" "C" Spring Rider

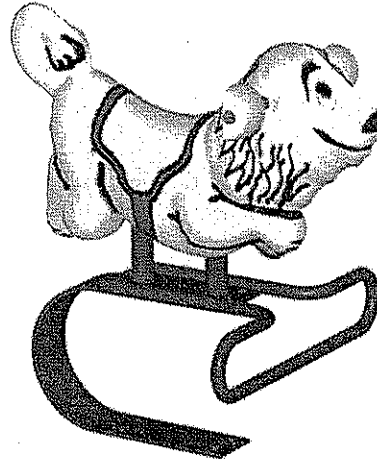

"C" Spring Riders

918

"Chipper Squirrel" "C" Spring Rider

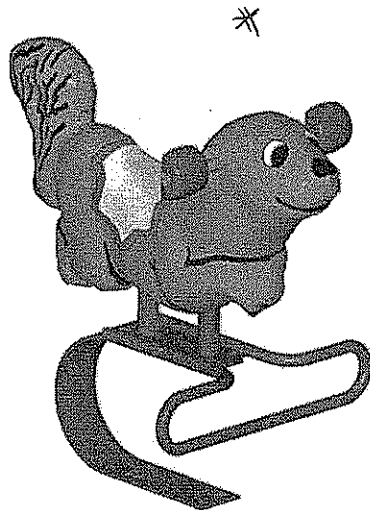

919

"Sammy Seal" "C" Spring Rider

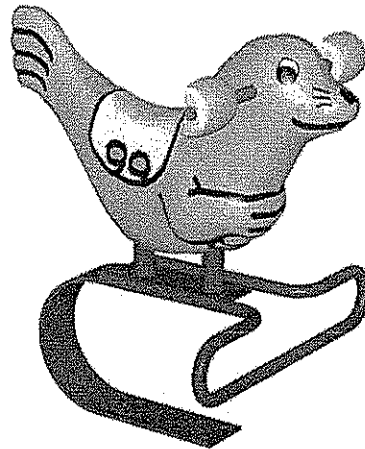

"C" Spring Riders

"C" Spring Riders

920

Moto-Cross "C" Spring Rider

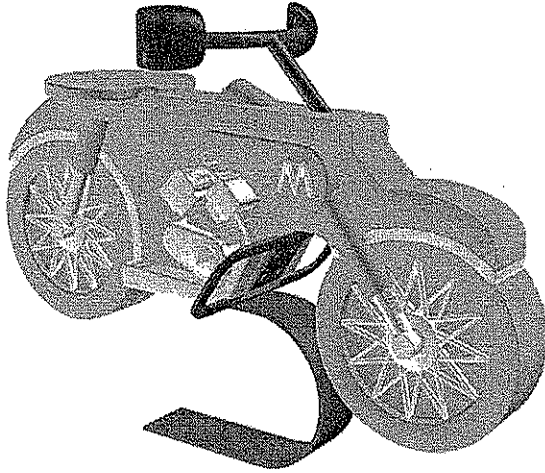

932

Frog "C" Spring Rider

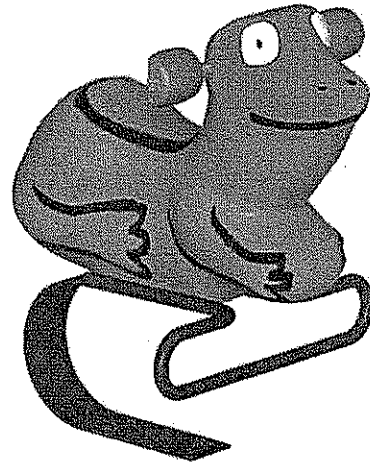

933

"Schnozz Wump" "C" Spring Rider

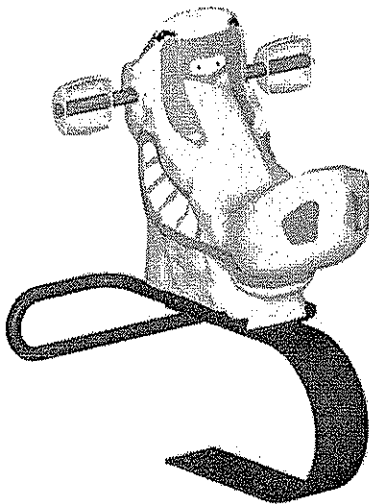

938

Elephant "C" Spring Rider

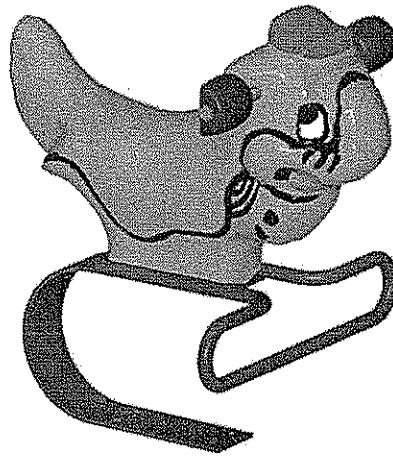



MIRACLE "C" Spring Riders
RECREATION EQUIPMENT COMPANY

940

Jet Interceptor "C" Spring Rider

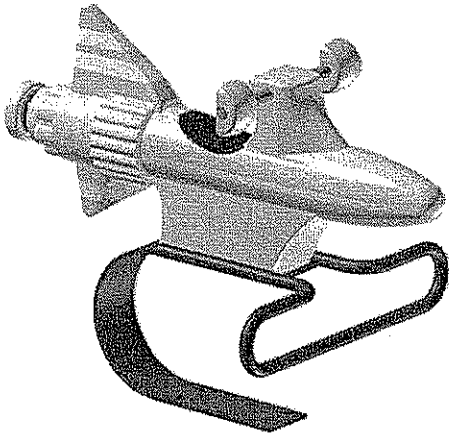

953

ATV "C" Spring Rider



"C" Spring Riders



Product Specifications

MIRACLE
RECREATION EQUIPMENT COMPANY

"C" Spring Riders
Hoppy & Pokey

962

Hoppy "C" Spring Rider

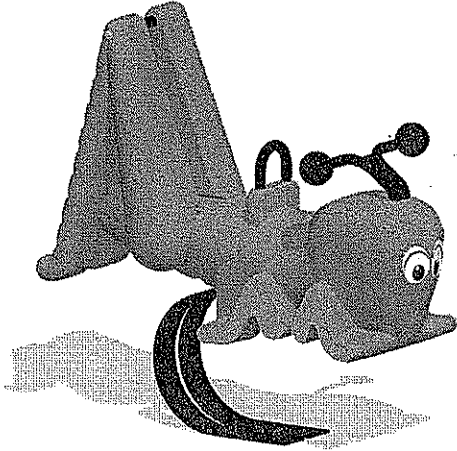

963

Pokey "C" Spring Rider

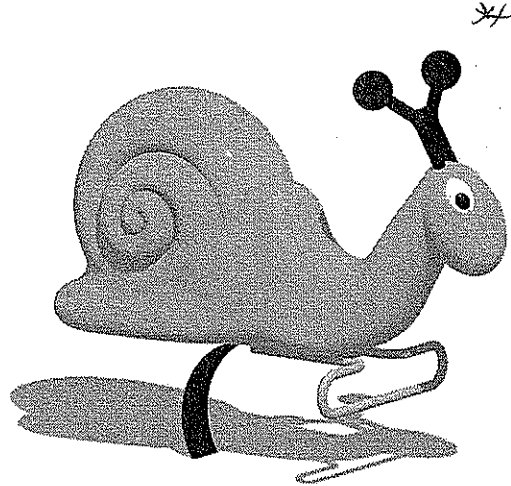

"C" Spring Riders



Product Specifications

Kids' Choice®

Arch Tire Swing and Arch Tire Swing Extension

714-852



Arch Tire Swing

(2) End Arches, (1) Header & (1) Tire Swing Assembly form (1) Complete Bay

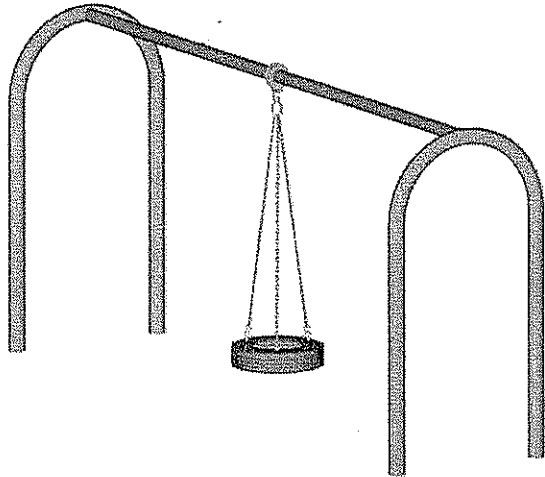

714-852-X

Arch Tire Swing Extension

(1) Extension Arch, (1) Header & (1) Tire Swing Assembly form (1) Additional Bay

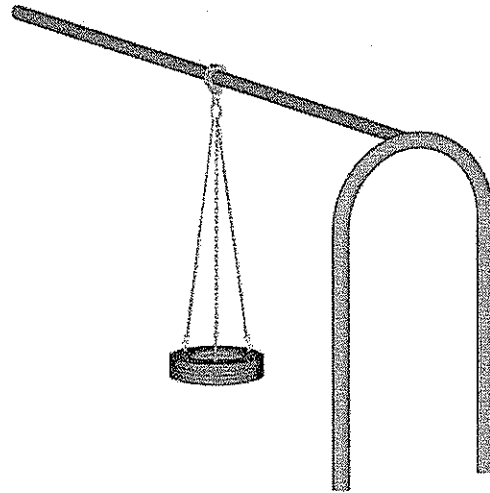

Arch Tire Swing & Extension

714-852, 714-852-X



Product Specifications

Kids' Choice®

Arch Swing Frames & Arch Swing Frame Extensions

714-852-2 & 714-852-2X

714-852-1H & 714-852-2HH

714-852-1HX & 714-852-2HHX

Arch Swing Frame*

(2) End Arches & (1) Header form (1) Bay for (2) Seats

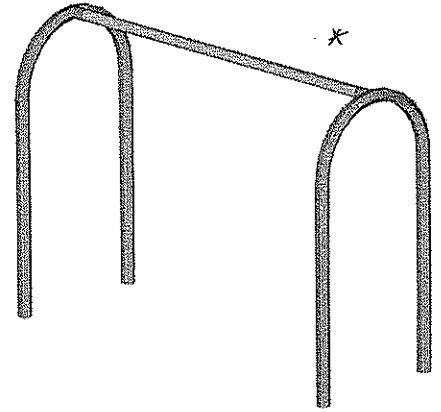

Arch Swing Frame Extension*

(1) Extension Arch & (1) Header form (1) additional Bay for (2) additional Seats

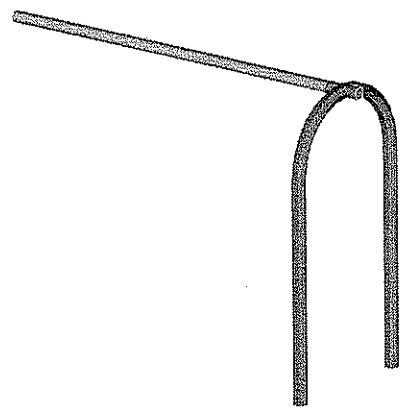

* Specifications for Model #s 714-852-2 and 714-852-2X encompass Model #s 714-852-4 and 714-852-6.

714-852-2 & 714-852-2X

714-852-1H & 714-852-2HH

714-852-1HX & 714-852-2HHX

Arch Swing Frame for Therapeutic Swing Seat

(2) End Arches & (1) Header form (1) Bay for (1) Therapeutic Swing Seat

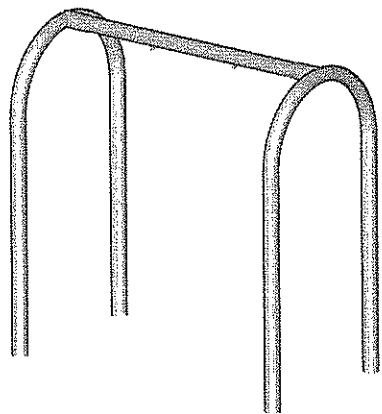

Arch Swing Frame for Therapeutic Swing Seats

(2) End Arches & (1) Header form (1) Bay for (2) additional Therapeutic Swing Seats

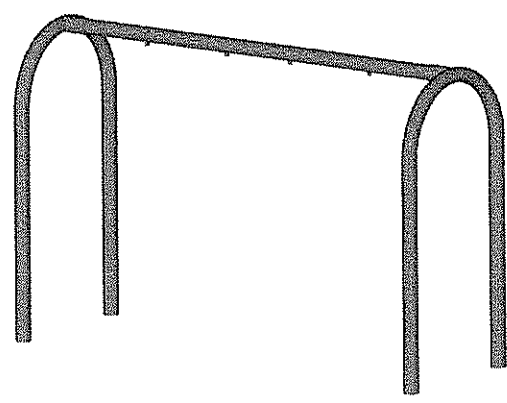

Arch Swing Frames & Extensions

714-852-2, 714-852-2X, 714-852-1H, 714-852-2HH, 714-852-1HX, 714-852-2HHX



Kids' Choice®

Arch Swing Frames & Arch Swing Frame Extensions

714-852-2 & 714-852-2X

714-852-1H & 714-852-2HH

714-852-1HX & 714-852-2HHX

Arch Swing Frame Extension for Therapeutic Swing Seat

- (1) Extension Arch & (1) Header form (1) additional Bay for
- (1) additional Therapeutic Swing Seat

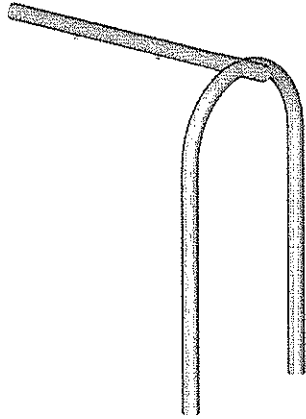

Arch Swing Frame Extension for Therapeutic Swing Seats

- (1) Extension Arch & (1) Header form (1) additional Bay for
- (2) additional Therapeutic Swing Seats

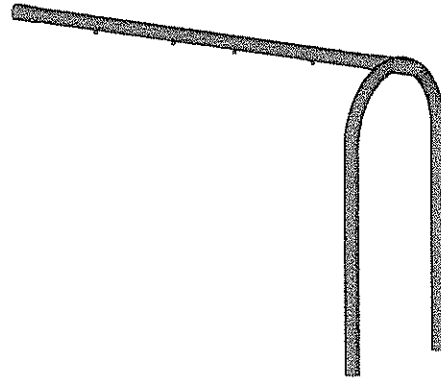

Arch Swing Frames & Extensions

714-852-2, 714-852-2X, 714-852-1H, 714-852-2HH, 714-852-1HX, 714-852-2HHX



Product Specifications

MIRACLE
RECREATION EQUIPMENT COMPANY

Whirl with Governor

303

Whirl

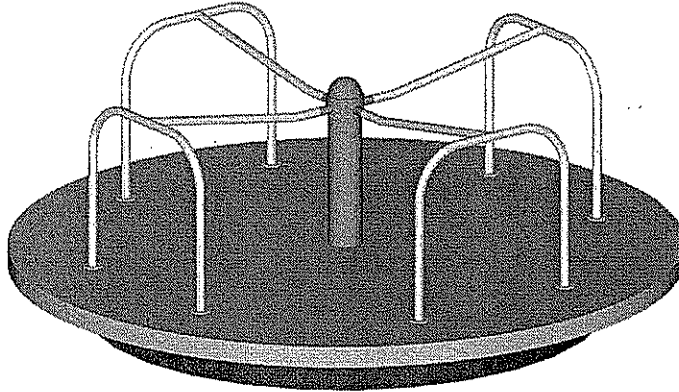

Whirl

303



Product Specifications

MIRACLE
RECREATION EQUIPMENT COMPANY

Peak Climber with Handrails - 2-Way, 3-Way & 4-Way & Add-ons

Peak Climber with Handrail & Add-ons

458-2

Peak Climber with Handrail,
2-Way

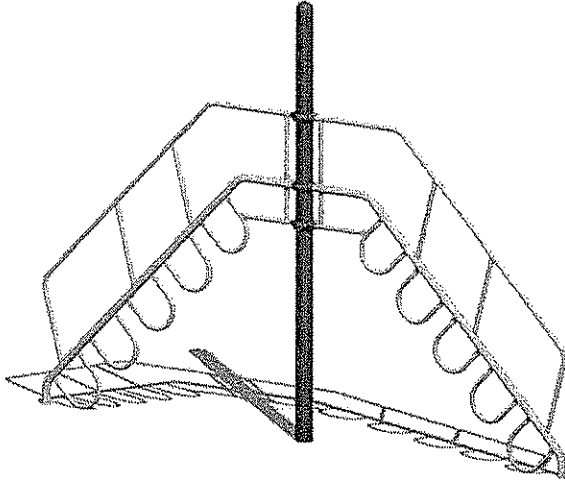

458-3

Peak Climber with Handrail,
3-Way

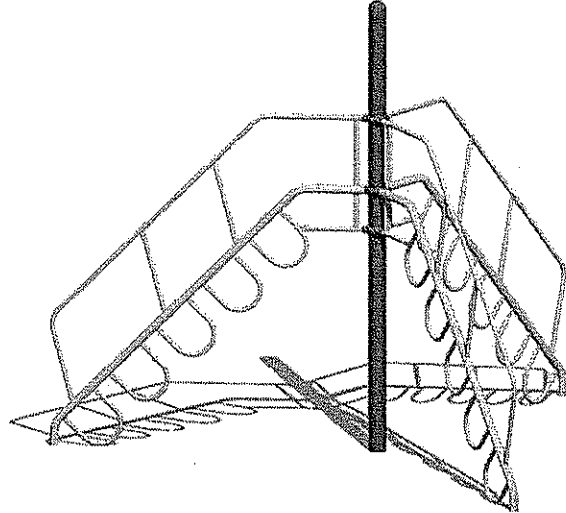

458-4

Peak Climber with Handrail,
4-Way

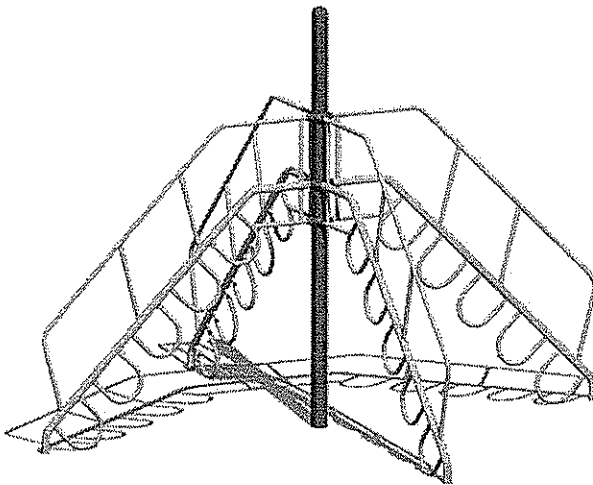

458-2A1

Peak Climber with Handrail,
2-Way with 1 Add-on

Note: Climber shown with Add-on 4582A-908.

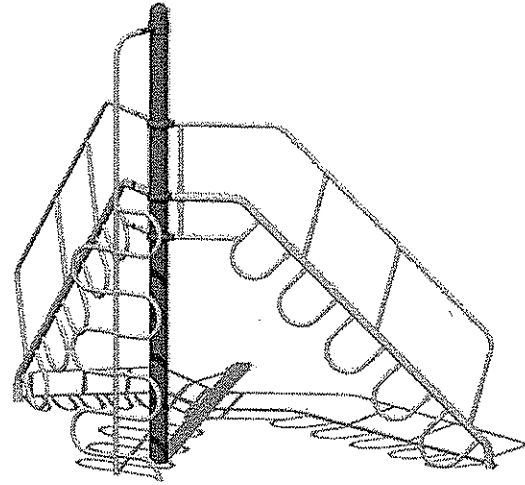

Peak Climber with Handrail & Add-ons

Peak Climber with Handrail - 2-Way, 3-Way & 4-Way; Climber Add-Ons

458-2A2

**Peak Climber with Handrail,
2-Way with 2 Add-ons**

Note: Climber shown with Add-ons 4582A-9695 & 4582A-721.

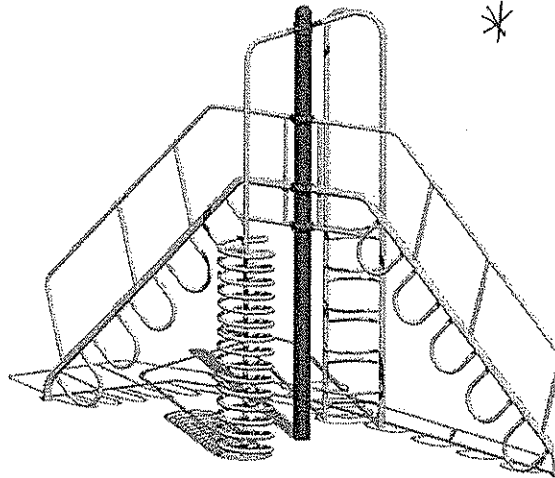



Product Specifications

MIRACLE
RECREATION EQUIPMENT COMPANY

Freestanding Typhoon Slides - Platform Heights of 6'-3", 9'-4" & 12'

Freestanding Typhoon Slides

65-748 and 65-749

Freestanding Typhoon Slide, 360°,
6'-3" Platform

Freestanding Typhoon Slide, 405°,
6'-3" Platform

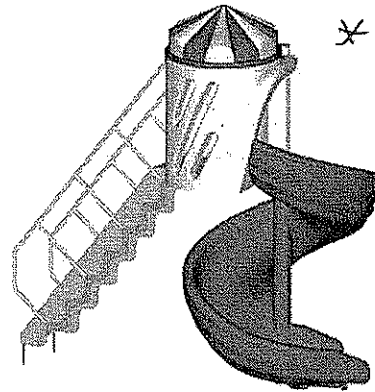
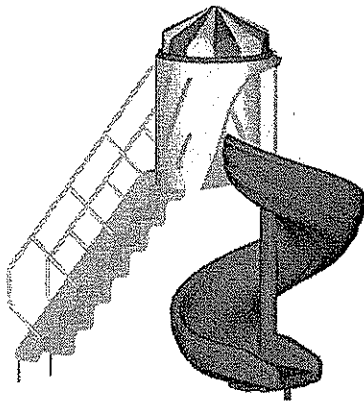

65-759 and 65-769

Freestanding Typhoon Slide, 630°,
9'-4" Platform

Freestanding Typhoon Slide, 855°,
12' Platform

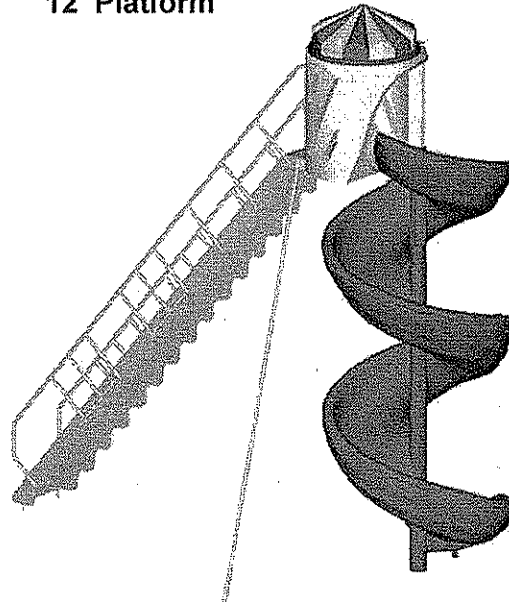
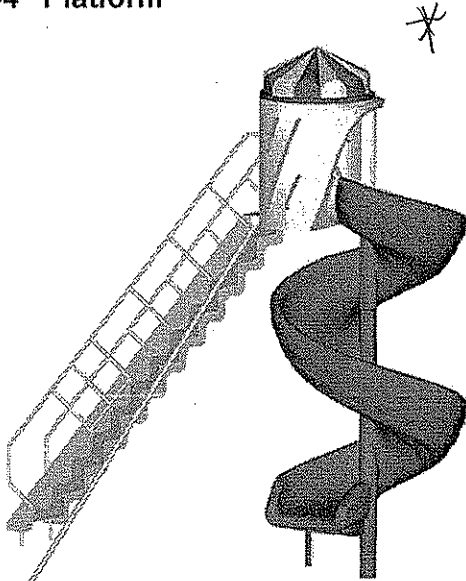

Twin Rider, Model #6081

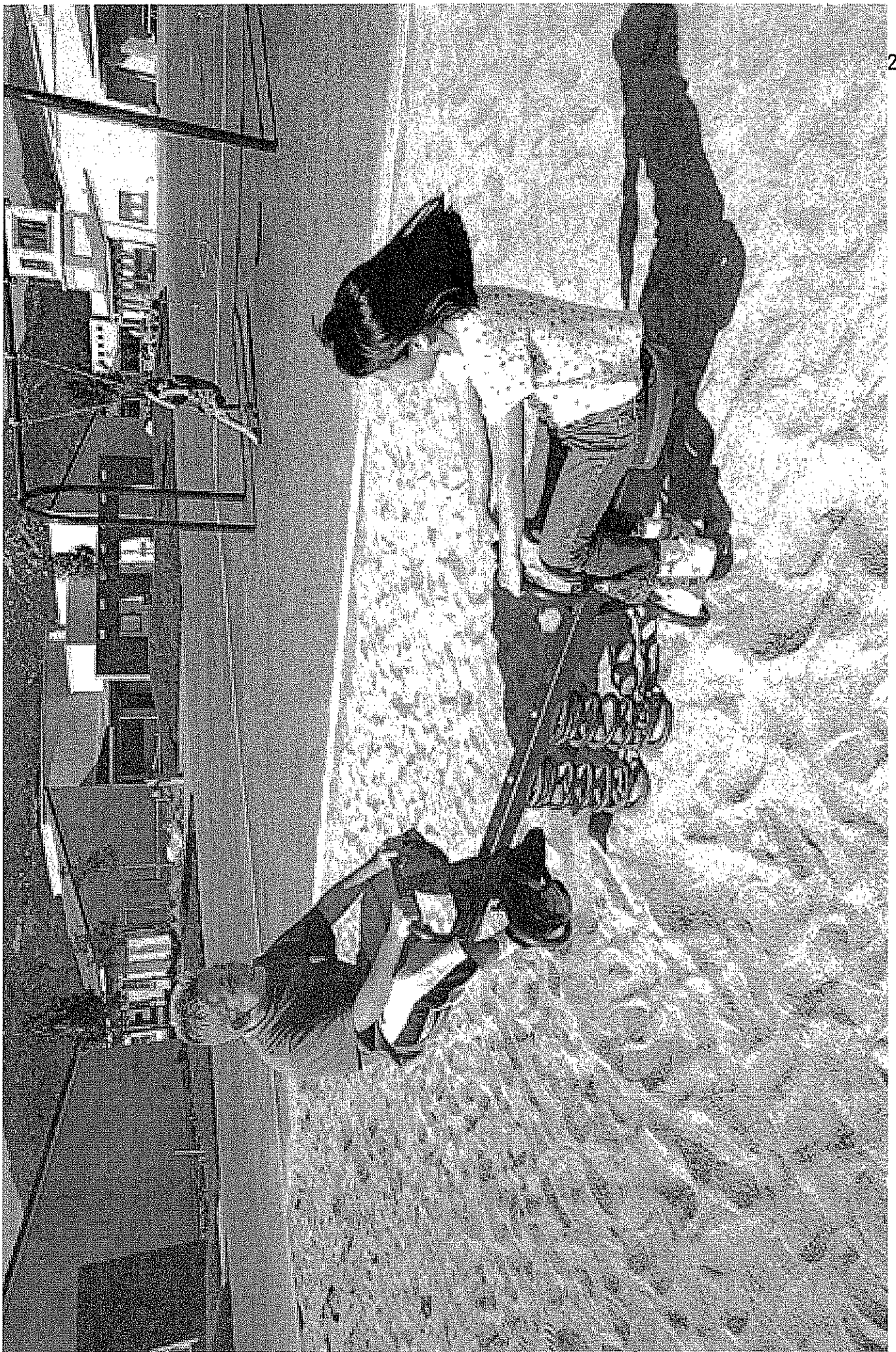



Product Specifications

MIRACLE Swing Seats RECREATION EQUIPMENT COMPANY

284, 2840 & 2841 ✕

Slashproof Seat

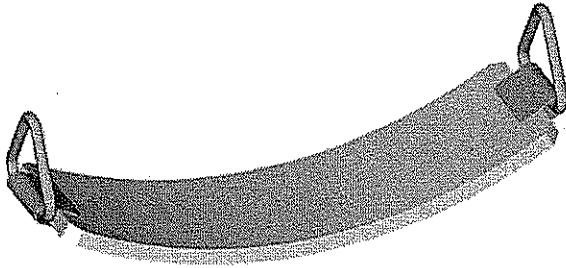

299 & 2990 ✕

360° Tot Seat

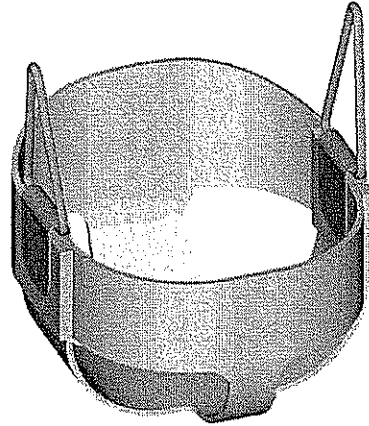

2720

Therapeutic Swing Seat

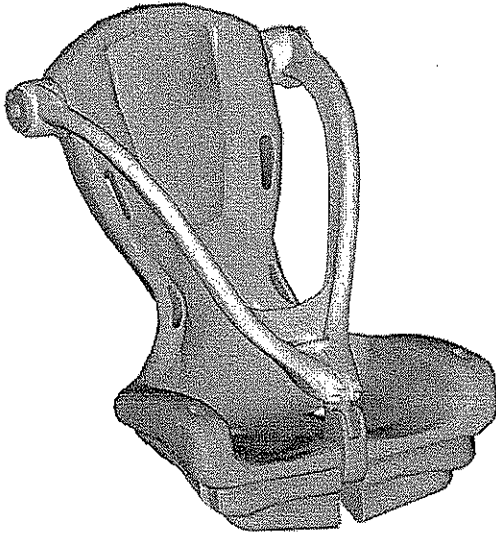

2721

Mirage Therapeutic Swing Seat

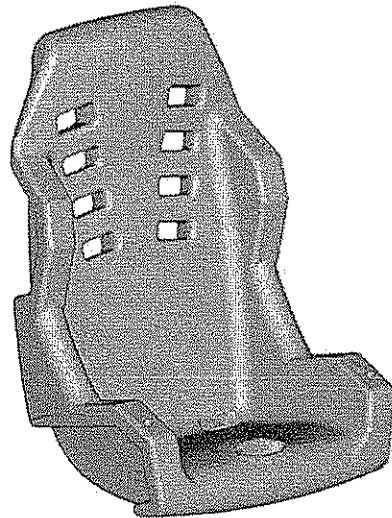

Swing Seats



Product Specifications

Kids' Choice®

Arch Swing Frames & Arch Swing Frame Extensions

714-852-2 & 714-852-2X

Arch Swing Frame*

(2) End Arches & (1) Header form (1) Bay for (2) Seats

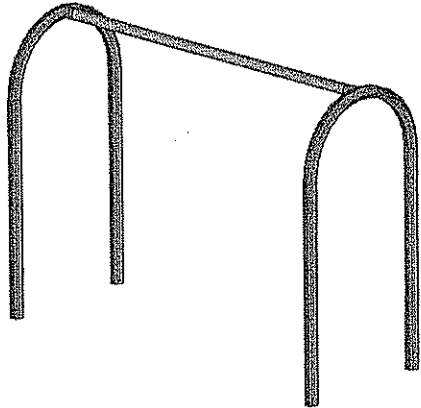

714-852-1H & 714-852-2HH

Arch Swing Frame Extension*

(1) Extension Arch & (1) Header form (1) additional Bay for (2) additional Seats

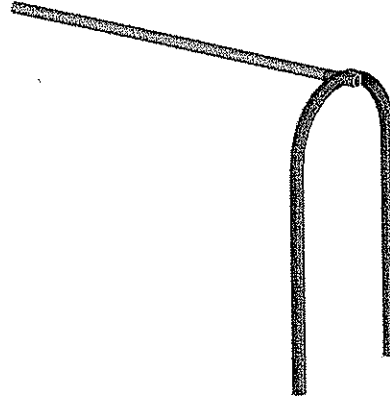

714-852-1HX & 714-852-2HHX

* Specifications for Model #s 714-852-2 and 714-852-2X encompass Model #s 714-852-4 and 714-852-6.

714-852-2 & 714-852-2X

Arch Swing Frame for Therapeutic Swing Seat

(2) End Arches & (1) Header form (1) Bay for (1) Therapeutic Swing Seat

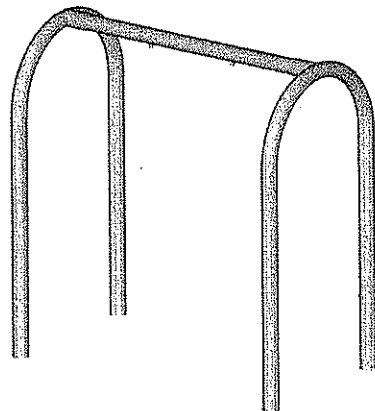

714-852-1H & 714-852-2HH

Arch Swing Frame for Therapeutic Swing Seats

(2) End Arches & (1) Header form (1) Bay for (2) additional Therapeutic Swing Seats

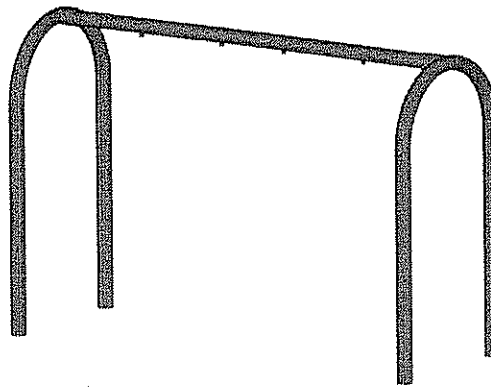

714-852-1HX & 714-852-2HHX

Arch Swing Frames & Extensions

714-852-2, 714-852-2X, 714-852-1H, 714-852-1HX, 714-852-2HH, 714-852-2HHH, 714-852-1H, 714-852-1HX, 714-852-2HHX



Kids' Choice®

Arch Swing Frames & Arch Swing Frame Extensions

714-852-2 & 714-852-2X

714-852-1H & 714-852-2HH

714-852-1HX & 714-852-2HHX

Arch Swing Frame Extension for Therapeutic Swing Seat

(1) Extension Arch & (1) Header form (1) additional Bay for (1) additional Therapeutic Swing Seat

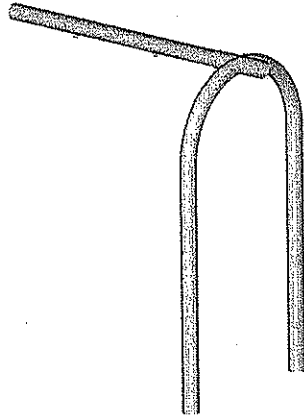

Arch Swing Frame Extension for Therapeutic Swing Seats

(1) Extension Arch & (1) Header form (1) additional Bay for (2) additional Therapeutic Swing Seats

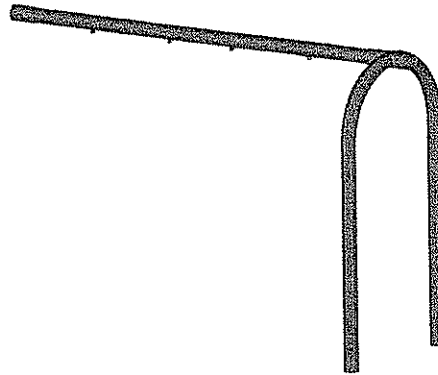

Arch Swing Frames & Extensions

714-852-2, 714-852-2X, 714-852-1H, 714-852-1HX, 714-852-2HH, 714-852-2HHX

Berwind Lake Wildlife Management Area

PLAYGROUND EQUIPMENT SHEET

Please complete the below information concerning the brand(s) of equipment being bid in relation to this project. If bidding "or equal" brands, please attach manufacturer's literature documenting that it meets the mandatory requirements stated in the specifications. Vendors should note the areas of the provided manufacturer's literature that adheres to the mandatory requirements outlined in the Request For Proposal.

Item No.	Equipment	Manufacturer	Model
1	Pool Area Playground Miracle tarantula climber, Model #4561, or equal.		
2	Pool Area Playground Miracle, 630° degree typhoon slide, Model #65749, or equal.		
3	Pool Area Playground Miracle chipper squirrel "C" spring rider model #918, or equal.		
4	Pool Area Playground Miracle pokey the snail "C" spring rider, Model #963, or equal.		
5	Pool Area Playground Miracle 5" OD arch tire swing complete model #714852, or equal.		
6	Pool Area Playground Miracle 5" OD arch 2 bay swing frame 4 seats REQ MC, Model #7148524, or equal.		
7	Pool Area Playground Miracle the whirl (merry-go-round), Model #303, or equal.		
8	Entrance Area Playground Miracle, peak climber, Model #4582a2, or equal.		
9	Entrance Area Playground Miracle, 405° degree typhoon slide, Model #65749, or equal.		
10	Entrance Area Playground Miracle twin rider, Model #6081, or equal.		

Berwind Lake Wildlife Management Area

PLAYGROUND EQUIPMENT SHEET

Item No.	Equipment	Manufacturer	Model
11	Office Area Playground Miracle swing part slash proof seat with clevis, Model #284, or equal.		
12	Office Area Playground Miracle swing part tot seat 360° with clevis model #299, or equal.		
13	Office Area Playground Miracle OD arch one bay swing frame with two (2) s/p seats MC, Model #7148522s, or equal.		
14	Engineered wood fiber or equal.		

Berwind Lake Wildlife Management Area Playground Equipment
PRICING SHEET

Item No.	Quantity	Description	Unit Price	Amount
1	1	Pool Area Playground Miracle tarantula climber, Model #4561, or equal.		
2	1	Pool Area Playground Miracle, 630° degree typhoon slide, Model #65749, or equal.		
3	1	Pool Area Playground Miracle chipper squirrel "C" spring rider model #918, or equal.		
4	1	Pool Area Playground Miracle pokey the snail "C" spring rider, Model #963, or equal.		
5	1	Pool Area Playground Miracle 5" OD arch tire swing complete model #714852, or equal.		
6	1	Pool Area Playground Miracle 5" OD arch 2 bay swing frame 4 seats REQ MC, Model #7148524, or equal.		
7	1	Pool Area Playground Miracle the whirl (merry-go-round), Model #303, or equal.		
8	1	Entrance Area Playground Miracle, peak climber, Model #4582a2, or equal.		
9	1	Entrance Area Playground Miracle, 405° degree typhoon slide, Model #65749, or equal.		
10	1	Entrance Area Playground Miracle twin rider, Model #6081, or equal.		
11	4	Office Area Playground Miracle swing part slash proof seat with clevis, Model #284, or equal.		
12	2	Office Area Playground Miracle swing part tot seat 360° with clevis model #299, or equal.		

PRICING SHEET

Item No.	Quantity	Description	Unit Price	Amount
13	1	Office Area Playground Miracle OD arch one bay swing frame with two (2) s/p seats MC, Model #7148522s, or equal.		
14	5,800 sq. ft.	Engineered wood fiber or equal.		
		TOTAL		

STATE OF WEST VIRGINIA
Purchasing Division

PURCHASING AFFIDAVIT

VENDOR OWING A DEBT TO THE STATE:

West Virginia Code §5A-3-10a provides that: No contract or renewal of any contract may be awarded by the state or any of its political subdivisions to any vendor or prospective vendor when the vendor or prospective vendor or a related party to the vendor or prospective vendor is a debtor and the debt owed is an amount greater than one thousand dollars in the aggregate.

PUBLIC IMPROVEMENT CONTRACTS & DRUG-FREE WORKPLACE ACT:

If this is a solicitation for a public improvement construction contract, the vendor, by its signature below, affirms that it has a written plan for a drug-free workplace policy in compliance with Article 1D, Chapter 21 of the *West Virginia Code*. The vendor **must** make said affirmation with its bid submission. Further, public improvement construction contract may not be awarded to a vendor who does not have a written plan for a drug-free workplace policy in compliance with Article 1D, Chapter 21 of the *West Virginia Code* and who has not submitted that plan to the appropriate contracting authority in timely fashion. For a vendor who is a subcontractor, compliance with Section 5, Article 1D, Chapter 21 of the *West Virginia Code* may take place before their work on the public improvement is begun.

ANTITRUST:

In submitting a bid to any agency for the state of West Virginia, the bidder offers and agrees that if the bid is accepted the bidder will convey, sell, assign or transfer to the state of West Virginia all rights, title and interest in and to all causes of action it may now or hereafter acquire under the antitrust laws of the United States and the state of West Virginia for price fixing and/or unreasonable restraints of trade relating to the particular commodities or services purchased or acquired by the state of West Virginia. Such assignment shall be made and become effective at the time the purchasing agency tenders the initial payment to the bidder.

I certify that this bid is made without prior understanding, agreement, or connection with any corporation, firm, limited liability company, partnership or person or entity submitting a bid for the same materials, supplies, equipment or services and is in all respects fair and without collusion or fraud. I further certify that I am authorized to sign the certification on behalf of the bidder or this bid.

LICENSING:

Vendors must be licensed and in good standing in accordance with any and all state and local laws and requirements by any state or local agency of West Virginia, including, but not limited to, the West Virginia Secretary of State's Office, the West Virginia Tax Department, West Virginia Insurance Commission, or any other state agencies or political subdivision. Furthermore, the vendor must provide all necessary releases to obtain information to enable the Director or spending unit to verify that the vendor is licensed and in good standing with the above entities.

CONFIDENTIALITY:

The vendor agrees that he or she will not disclose to anyone, directly or indirectly, any such personally identifiable information or other confidential information gained from the agency, unless the individual who is the subject of the information consents to the disclosure in writing or the disclosure is made pursuant to the agency's policies, procedures and rules. Vendor further agrees to comply with the Confidentiality Policies and Information Security Accountability Requirements, set forth in <http://www.state.wv.us/admin/purchase/privacy/noticeConfidentiality.pdf>.

Under penalty of law for false swearing (*West Virginia Code* §61-5-3), it is hereby certified that the vendor affirms and acknowledges the information in this affidavit and is in compliance with the requirements as stated.

Vendor's Name: _____

Authorized Signature: _____ Date: _____

State of West Virginia

VENDOR PREFERENCE CERTIFICATE

Certification and application* is hereby made for Preference in accordance with West Virginia Code, §5A-3-37. (Does not apply to construction contracts). West Virginia Code, §5A-3-37, provides an opportunity for qualifying vendors to request (at the time of bid) preference for their residency status. Such preference is an evaluation method only and will be applied only to the cost bid in accordance with the West Virginia Code. This certificate for application is to be used to request such preference. The Purchasing Division will make the determination of the Resident Vendor Preference, if applicable.

- 1. Application is made for 2.5% resident vendor preference for the reason checked: Bidder is an individual resident vendor and has resided continuously in West Virginia for four (4) years immediately preceding the date of this certification; or, Bidder is a partnership, association or corporation resident vendor and has maintained its headquarters or principal place of business continuously in West Virginia for four (4) years immediately preceding the date of this certification; or 80% of the ownership interest of Bidder is held by another individual, partnership, association or corporation resident vendor who has maintained its headquarters or principal place of business continuously in West Virginia for four (4) years immediately preceding the date of this certification; or, Bidder is a nonresident vendor which has an affiliate or subsidiary which employs a minimum of one hundred state residents and which has maintained its headquarters or principal place of business within West Virginia continuously for the four (4) years immediately preceding the date of this certification; or,
2. Application is made for 2.5% resident vendor preference for the reason checked: Bidder is a resident vendor who certifies that, during the life of the contract, on average at least 75% of the employees working on the project being bid are residents of West Virginia who have resided in the state continuously for the two years immediately preceding submission of this bid; or,
3. Application is made for 2.5% resident vendor preference for the reason checked: Bidder is a nonresident vendor employing a minimum of one hundred state residents or is a nonresident vendor with an affiliate or subsidiary which maintains its headquarters or principal place of business within West Virginia employing a minimum of one hundred state residents who certifies that, during the life of the contract, on average at least 75% of the employees or Bidder's affiliate's or subsidiary's employees are residents of West Virginia who have resided in the state continuously for the two years immediately preceding submission of this bid; or,
4. Application is made for 5% resident vendor preference for the reason checked: Bidder meets either the requirement of both subdivisions (1) and (2) or subdivision (1) and (3) as stated above; or,
5. Application is made for 3.5% resident vendor preference who is a veteran for the reason checked: Bidder is an individual resident vendor who is a veteran of the United States armed forces, the reserves or the National Guard and has resided in West Virginia continuously for the four years immediately preceding the date on which the bid is submitted; or,
6. Application is made for 3.5% resident vendor preference who is a veteran for the reason checked: Bidder is a resident vendor who is a veteran of the United States armed forces, the reserves or the National Guard, if, for purposes of producing or distributing the commodities or completing the project which is the subject of the vendor's bid and continuously over the entire term of the project, on average at least seventy-five percent of the vendor's employees are residents of West Virginia who have resided in the state continuously for the two immediately preceding years.

Bidder understands if the Secretary of Revenue determines that a Bidder receiving preference has failed to continue to meet the requirements for such preference, the Secretary may order the Director of Purchasing to: (a) reject the bid; or (b) assess a penalty against such Bidder in an amount not to exceed 5% of the bid amount and that such penalty will be paid to the contracting agency or deducted from any unpaid balance on the contract or purchase order.

By submission of this certificate, Bidder agrees to disclose any reasonably requested information to the Purchasing Division and authorizes the Department of Revenue to disclose to the Director of Purchasing appropriate information verifying that Bidder has paid the required business taxes, provided that such information does not contain the amounts of taxes paid nor any other information deemed by the Tax Commissioner to be confidential.

Under penalty of law for false swearing (West Virginia Code, §61-5-3), Bidder hereby certifies that this certificate is true and accurate in all respects; and that if a contract is issued to Bidder and if anything contained within this certificate changes during the term of the contract, Bidder will notify the Purchasing Division in writing immediately.

Bidder: _____ Signed: _____

Date: _____ Title: _____

*Check any combination of preference consideration(s) indicated above, which you are entitled to receive.