

**GENERAL TERMS & CONDITIONS
REQUEST FOR QUOTATION (RFQ) AND REQUEST FOR PROPOSAL (RFP)**

1. Awards will be made in the best interest of the State of West Virginia.
2. The State may accept or reject in part, or in whole, any bid.
3. All quotations are governed by the *West Virginia Code* and the *Legislative Rules* of the Purchasing Division.
4. Prior to any award, the apparent successful vendor must be properly registered with the Purchasing Division and have paid the required \$125 fee.
5. All services performed or goods delivered under State Purchase Order/Contracts are to be continued for the term of the Purchase Order/Contracts, contingent upon funds being appropriated by the Legislature or otherwise being made available. In the event funds are not appropriated or otherwise available for these services or goods, this Purchase Order/Contract becomes void and of no effect after June 30.
6. Payment may only be made after the delivery and acceptance of goods or services.
7. Interest may be paid for late payment in accordance with the *West Virginia Code*.
8. Vendor preference will be granted upon written request in accordance with the *West Virginia Code*.
9. The State of West Virginia is exempt from federal and state taxes and will not pay or reimburse such taxes.
10. The Director of Purchasing may cancel any Purchase Order/Contract upon 30 days written notice to the seller.
11. The laws of the State of West Virginia and the *Legislative Rules* of the Purchasing Division shall govern all rights and duties under the Contract, including without limitation the validity of this Purchase Order/Contract.
12. Any reference to automatic renewal is hereby deleted. The Contract may be renewed only upon mutual written agreement of the parties.
13. **BANKRUPTCY:** In the event the vendor/contractor files for bankruptcy protection, this Contract may be deemed null and void, and terminated without further order.
14. **HIPAA BUSINESS ASSOCIATE ADDENDUM:** The West Virginia State Government HIPAA Business Associate Addendum (BAA), approved by the Attorney General, and available online at the Purchasing Division's web site (<http://www.state.wv.us/admin/purchase/vrc/hipaa.htm>) is hereby made part of the agreement. Provided that, the Agency meets the definition of a Cover Entity (45 CFR §160.103) and will be disclosing Protected Health Information (45 CFR §160.103) to the vendor.
15. **WEST VIRGINIA ALCOHOL & DRUG-FREE WORKPLACE ACT:** If this Contract constitutes a public improvement construction contract as set forth in Article 1D, Chapter 21 of the West Virginia Code ("The West Virginia Alcohol and Drug-Free Workplace Act"), then the following language shall hereby become part of this Contract: "The contractor and its subcontractors shall implement and maintain a written drug-free workplace policy in compliance with the West Virginia Alcohol and Drug-Free Workplace Act, as set forth in Article 1D, Chapter 21 of the West Virginia Code. The contractor and its subcontractors shall provide a sworn statement in writing, under the penalties of perjury, that they maintain a valid drug-free work place policy in compliance with the West Virginia and Drug-Free Workplace Act. It is understood and agreed that this Contract shall be cancelled by the awarding authority if the Contractor: 1) Fails to implement its drug-free workplace policy; 2) Fails to provide information regarding implementation of the contractor's drug-free workplace policy at the request of the public authority; or 3) Provides to the public authority false information regarding the contractor's drug-free workplace policy."

INSTRUCTIONS TO BIDDERS

1. Use the quotation forms provided by the Purchasing Division.
2. **SPECIFICATIONS:** Items offered must be in compliance with the specifications. Any deviation from the specifications must be clearly indicated by the bidder. Alternates offered by the bidder as **EQUAL** to the specifications must be clearly defined. A bidder offering an alternate should attach complete specifications and literature to the bid. The Purchasing Division may waive minor deviations to specifications.
3. Complete all sections of the quotation form.
4. Unit prices shall prevail in case of discrepancy.
5. All quotations are considered F.O.B. destination unless alternate shipping terms are clearly identified in the quotation.
6. **BID SUBMISSION:** All quotations must be delivered by the bidder to the office listed below prior to the date and time of the bid opening. Failure of the bidder to deliver the quotations on time will result in bid disqualifications: Department of Administration, Purchasing Division, 2019 Washington Street East, P.O. Box 50130, Charleston, WV 25305-0130

MANDATORY PRE-BID SIGN-IN ATTENDANCE SHEET

PRINT LEGIBLY

RFQ # : 14563
Project: Lower Dempsey Branch Highway

Bid Date: 3-11-09
Pre-Bid Date: 2-11-09

Name : Robert Barnes
Company: Barnes Excl. Inc.
Address: P.O. Box 13384
Sissonville
WV. 25360
Phone #: 304-984-1725
Fax #: 304-984-0074
Email : NONE

Name : RICH WATTS
Company: ACKENHILL ENGINEER GEOLOGIST
Address: Box 416 Herb Ind. Park
Box Nitro, WV 25143
Phone #: 776-7473
Fax #: 776-6426
Email : NONE

Name : BRIAN BERNATOWICZ
Company: CONGREL UP INC
Address: PO Box 243
SIMPSON WV 26435
Phone #: 304-739-4397
Fax #: 304-739-4401
Email : NONE

Name : Basil CARPENTER
Company: Basil CARPENTER Ex 1
Address: 333 A Call Rd
Chas WVA 25312
Phone #: (304) 546-1601
Fax #: (304) 984-3528
Email :

Name : Doug Vincent
Company: BREAKAWAY INC
Address: 1075 old Turnpike Rd
Sutton WV 26601
Phone #: 765-5317
Fax #: 765-5389
Email :

Name : TIM CART
Company: E.L. ROBINSON
Address: 5028 WASH. ST. W.
CHALLOSTON, WV 25313
Phone #: (304) 776-7473
Fax #: 776-6426
Email : tim@elrobinson.com

Name : Pete Thexton
Company: Thexton Const Inc
Address: PO Box 13279 Charleston
WV 25312
Phone #: 304 984 2299
Fax #: 304 984 2384
Email :

Name : Eugene A. McKenzie
Company: The McKenzie Co.
Address: 315-7th St
Reinette WVA 25912
Phone #: 304-438-5215
Fax #: 304-438-5215
Email :

MANDATORY PRE-BID SIGN-IN ATTENDANCE SHEET

PRINT LEGIBLY

RFQ # : 14563
Project: Lower Dempsey Branch Highway

Bid Date: 3-11-09
Pre-Bid Date: 2-11-09

Name : Brad Duffield
Company: WV DEP
Address: Oak Hill WV

Phone #: 465-1911
Fax # : _____
Email : _____

Name : Donna Jordan
Company: Donnas Septic Service
Address: P.O. Box 28
North Matewan
W.VA 25118
Phone# : 304-426-4746
Fax # : same
Email : donna-1974@aol.com

Name : David H. Bowman
Company: GREEN MOUNTAIN CO
Address: 511 50th STREET
CHRISTIAN WV
25304
Phone #: 304 925 0253
Fax # : 925 9230
Email : Sody_Maye@OLC.com

Name : Tara Hogerman
Company: Hogerman's
Address: P.O. Box 447
Jolo W.VA 28125
Phone# : 304-967-5308
Fax # : _____
Email : Tara-Dawn07@aol.com

Name : Randy Carpenter
Company: Carpenter Reclamation
Address: P.O. Box 13015
8155onville, WV
25360
Phone #: 304-984-1115
Fax # : 984-2770
Email : _____

Name : ALLEN MURDACK
Company: Berment Construction supplies
Address: P.O. Box 9046
Berment WV 25030
Phone# : 304 548-7004
Fax # : 304 548-7133
Email : _____

Name : Alex Justice
Company: CJS Contracting
Address: P.O. Box 37
Crum WVA 25669
Phone #: (304) 393-4907
Fax # : _____
Email : _____

Name : Kevin Houck
Company: Pineville Paving & Excavating, Inc.
Address: P.O. Box 1290
Pineville WV 24874
Phone# : 304 732-8303
Fax # : 304 732-7855
Email : _____

- Item 1:** Reclamation Plans, Sheet No. 8; Bat gates will replace the wet mine seals at M0-1, M0-2, M0-3, and M0-4. A detail of the bat gate is included with this addendum.
- Item 2:** The contractors were told that it would be the Contractor's responsibility to obtain any necessary highway permits for installing the pipe culvert across the road.
- Item 3:** A revised copy of the Contractor's bid sheet is included with this addendum. Changes in Item No. 7-1 and 7-2 are shown reflecting the addition of the bat gates and the reduced number of modified wet mine seals.
- Item 4:** The "Division of Land Restoration" is no longer needed.
- Item 5:** Contractor should dig test pit prior to installing underdrain to locate any utility.

Questions & Answers:

- Item 6:** Q: Where does the rock fill extend?
A: The rock fill will be installed as shown on the plans.
- Item 7:** Q: A question was asked concerning information for the installation of the specified "cleanout" on the 12-inch diameter pipe?
A: The cleanout will be installed as shown on the plans. A detail of the cleanout will be included with this addendum.
- Item 8:** Q: A question was asked what was to be done with the excavation waste?
A: It would be the Contractor's responsibility to obtain an approved waste location in accordance with the standard NEPA requirements.
- Item 9:** Q: The question was asked about payment for the demolition of the concrete block portal?
A: The payment will be incidental to Item 7-1 as stated in the specifications 7.4.1 and 7.5.1.
- Item 10:** Q: How far does the underdrain extend?
A: Underdrain to be installed as shown on the plans.
- Item 11:** Q: Where will the drainage from the portals go?
A: It will be directed to the channels and natural drainage as shown on the plans.

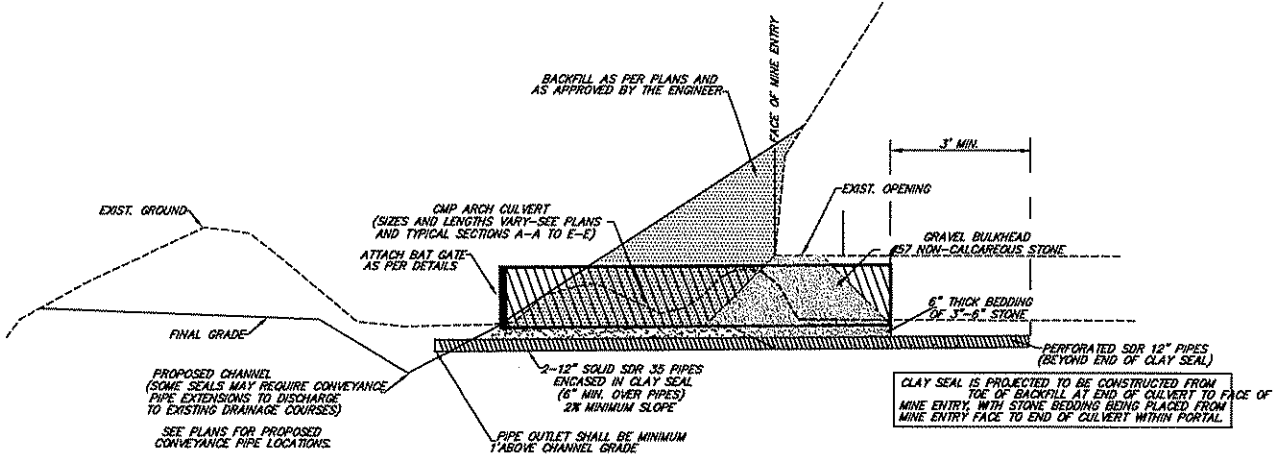

TYPICAL CONSTRUCTION DETAILS

Not to Scale

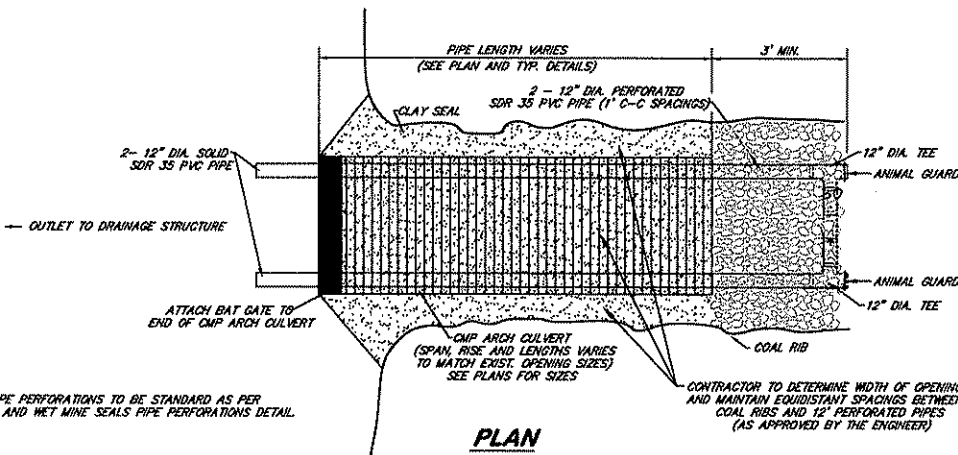

**PLAN
TYPICAL DETAIL
BAT GATE**

Not to Scale

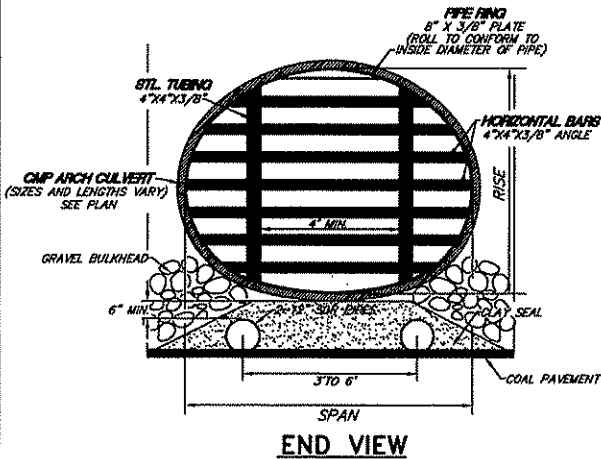

END VIEW

HORIZONTAL BAR SPACINGS ARE NOT TO BE ALTERED. AN ADDITIONAL HORIZONTAL 1 1/2\"/>

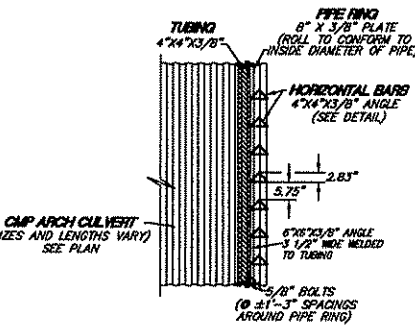

**PIPE RING SECTION
(ALTERNATE)**

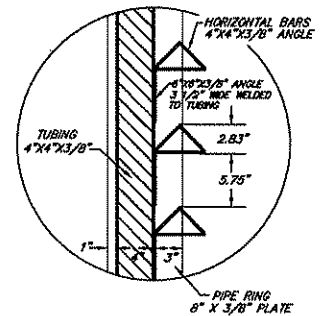

HORIZONTAL BAR DETAIL

**PIPE BAT GATE
TYPICAL DETAIL**

RECEIVED AML OAK HILL
 2009 FEB 13 AM 9:24

DRAWING TITLE	
DATE FEBRUARY, 2009	BAT GATE DETAIL
SCALE NOT TO SCALE	
DRAWING NUMBER D-2	

PROJECT INFORMATION
**LOWER DEMPSEY
 LOGAN COUNTY, WEST VIRGINIA**



NO.	DATE	REVISION	BY

**ACKENHEIL
 ENGINEERS
 GEOLOGISTS**

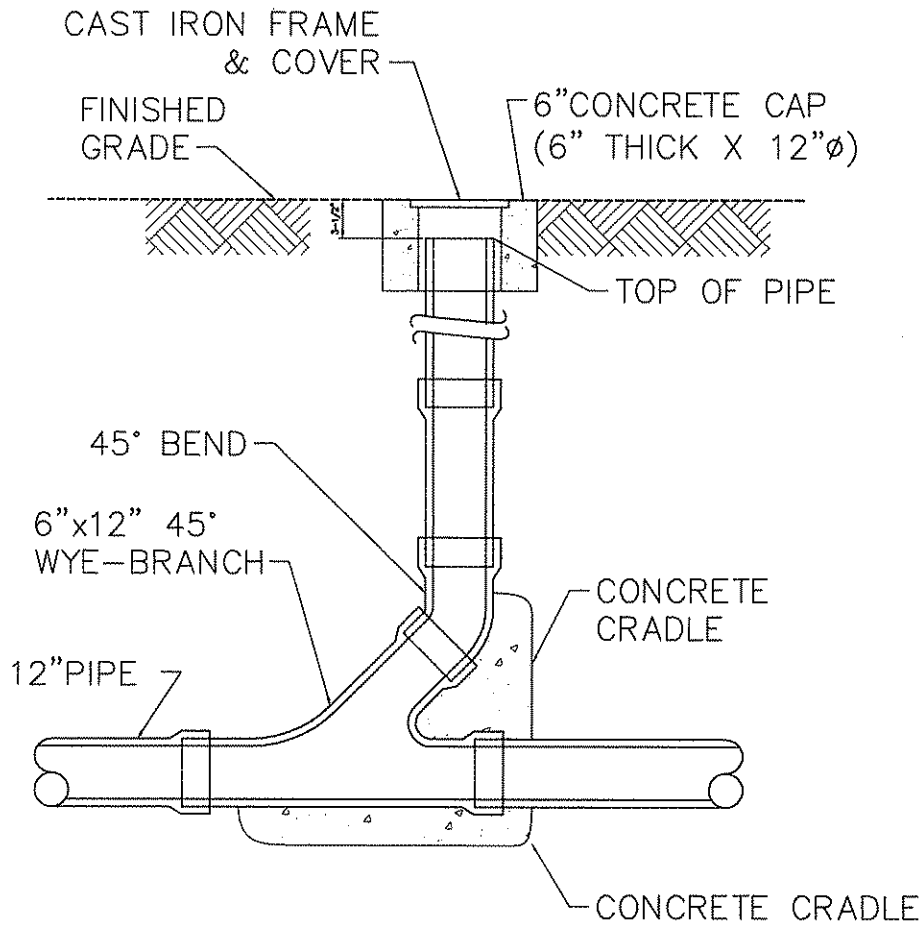

RECEIVED AML OAK HILL
 2009 FEB 13 AM 9:24

DETAIL
IN-LINE CLEANOUT
 NOT TO SCALE

DATE FEBRUARY, 2009	DRAWING TITLE IN-LINE CLEANOUT DETAIL
SCALE NOT TO SCALE	
DRAWING NUMBER D-1	

PROJECT INFORMATION
**LOWER DEMPSEY
 LOGAN COUNTY, WEST VIRGINIA**

NO.	DATE	REVISION	BY

**ACKENHEIL
 ENGINEERS
 GEOLOGISTS**

