



State of West Virginia
 Department of Administration
 Purchasing Division
 2019 Washington Street East
 Post Office Box 50130
 Charleston, WV 25305-0130

Request for Quotation

RFQ NUMBER
 DEP14379

PAGE
 1

ADDRESS CORRESPONDENCE TO ATTENTION OF
 CHUCK BOWMAN
 304-558-2157

RFQ COPY
 TYPE NAME/ADDRESS HERE

VENDOR

SHIP TO

ENVIRONMENTAL PROTECTION
 DEPARTMENT OF
 OFFICE OF AML&R
 601 57TH STREET SE
 CHARLESTON, WV
 25304 304-926-0499

DATE PRINTED	TERMS OF SALE	SHIP VIA	F.O.B.	FREIGHT TERMS
08/19/2008				

BID OPENING DATE: 09/09/2008 BID OPENING TIME 01:30PM

LINE	QUANTITY	UOP	CAT. NO.	ITEM NUMBER	UNIT PRICE	AMOUNT
***** ADDENDUM NO. 1 *****						
ADDENDUM ISSUED FOR LAUREL RUN DOSER PROJECT TO DIS- TRIBUTE THE PRE-BID SIGN-IN SHEETS FROM THE 08/05/08 MANDATORY PRE-BID MEETING AS WELL AS THREE ADDITIONAL DRAWINGS AND ONE PAGE OF SUPPLEMENTARY INFORMATION RELATING TO THE PROJECT DESIGN.						
BID OPENING DATE AND TIME REMAIN UNCHANGED AS 09/09/08 AT 1:30 PM.						
***** NO OTHER CHANGES *****						
0001		JB		962-73		
1 RECLAMATION: RESTORATION OF LAND & OTHER PROPERTIES						

SEE REVERSE SIDE FOR TERMS AND CONDITIONS

SIGNATURE	TELEPHONE	DATE
TITLE	FEIN	ADDRESS CHANGES TO BE NOTED ABOVE

WHEN RESPONDING TO RFQ, INSERT NAME AND ADDRESS IN SPACE ABOVE LABELED 'VENDOR'

**GENERAL TERMS & CONDITIONS
REQUEST FOR QUOTATION (RFQ) AND REQUEST FOR PROPOSAL (RFP)**

1. Awards will be made in the best interest of the State of West Virginia.
2. The State may accept or reject in part, or in whole, any bid.
3. All quotations are governed by the *West Virginia Code* and the *Legislative Rules* of the Purchasing Division.
4. Prior to any award, the apparent successful vendor must be properly registered with the Purchasing Division and have paid the required \$125.00 registration fee.
5. All services performed or goods delivered under State Purchase Orders/Contracts are to be continued for the term of the Purchase Order/Contract, contingent upon funds being appropriated by the Legislature or otherwise being made available. In the event funds are not appropriated or otherwise available for these services or goods, this Purchase Order/Contract becomes void and of no effect after June 30.
6. Payment may only be made after the delivery and acceptance of goods or services.
7. Interest may be paid for late payment in accordance with the *West Virginia Code*.
8. Vendor preference will be granted upon written request in accordance with the *West Virginia Code*.
9. The State of West Virginia is exempt from federal and state taxes and will not pay or reimburse such taxes.
10. The Director of Purchasing may cancel any Purchase Order/Contract upon 30 days written notice to the seller.
11. The laws of the State of West Virginia and the *Legislative Rules* of the Purchasing Division shall govern all rights and duties under the Contract, including without limitation the validity of this Purchase Order/Contract.
12. Any reference to automatic renewal is hereby deleted. The Contract may be renewed only upon mutual written agreement of the parties.
13. **BANKRUPTCY:** In the event the vendor/contractor files for bankruptcy protection, this Contract may be deemed null and void, and terminated without further order.
14. **HIPAA Business Associate Addendum:** The West Virginia State Government HIPAA Business Associate Addendum (BAA), approved by the Attorney General, and available online at the Purchasing Division's web site (<http://www.state.wv.us/admin/purchase/vrc/hipaa.htm>) is hereby made part of the agreement. Provided that, the Agency meets the definition of a Covered Entity (45 CFR §160.103) and will be disclosing Protected Health Information (45 CFR §160.103) to the vendor.
15. **West Virginia Alcohol & Drug-Free Workplace Act:** If this Contract constitutes a public improvement construction contract as set forth in Article 1D, Chapter 21 of the West Virginia Code ("The West Virginia Alcohol and Drug-Free Workplace Act"), then the following language shall hereby become part of this Contract: "The contractor and its subcontractors shall implement and maintain a written drug-free workplace policy in compliance with the West Virginia Alcohol and Drug-Free Workplace Act, as set forth in Article 1D, Chapter 21 of the West Virginia Code. The contractor and its subcontractors shall provide a sworn statement in writing, under the penalties of perjury, that they maintain a valid drug-free work place policy in compliance with the West Virginia Alcohol and Drug-Free Workplace Act. It is understood and agreed that this Contract shall be cancelled by the awarding authority if the Contractor: 1) Fails to implement its drug-free workplace policy; 2) Fails to provide information regarding implementation of the contractor's drug-free workplace policy at the request of the public authority; or 3) Provides to the public authority false information regarding the contractor's drug-free workplace policy."

INSTRUCTIONS TO BIDDERS

1. Use the quotation forms provided by the Purchasing Division.
2. **SPECIFICATIONS:** Items offered must be in compliance with the specifications. Any deviation from the specifications must be clearly indicated by the bidder. Alternates offered by the bidder as **EQUAL** to the specifications must be clearly defined. A bidder offering an alternate should attach complete specifications and literature to the bid. The Purchasing Division may waive minor deviations to specifications.
3. Complete all sections of the quotation form.
4. Unit prices shall prevail in cases of discrepancy.
5. All quotations are considered F.O.B. destination unless alternate shipping terms are clearly identified in the quotation.
6. **BID SUBMISSION:** All quotations must be delivered by the bidder to the office listed below prior to the date and time of the bid opening. Failure of the bidder to deliver the quotations on time will result in bid disqualifications:
Department of Administration, Purchasing Division, 2019 Washington Street East, P.O. Box 50130,
Charleston, WV 25305-0130

MANDATORY PRE-BID SIGN-IN ATTENDANCE SHEET

RFQ # : 14379
 Project: LAUREL Run DOSSA

Bid Date: 9/9/08
 Pre-Bid Date: 8/5/08

Name : JAMES ALLEN
 Company: J F ALLEN CO
 Address: ~~RT~~ PO Box 2019
Duckhannon WV 26201

Phone #: 304 472 8890
 Fax #: 304 472 8897
 Email : _____

Name : Spencer C Wooddell
 Company: Cowgirl Up Inc.
 Address: PO Box 243
Simpson, WVA 26435

Phone #: 304 739 4397
 Fax #: 304 739 4397
 Email : _____

Name : Mike Jenkins
 Company: AQUAFIX SYSTEMS INC
 Address: 301 Maple Lane
Kingwood WV 26537

Phone #: 304-329-1056
 Fax #: 304-329-1217
 Email : mjj@aquafix.com

Name : Charlene Pretzel
 Company: JL Pretzel Contracting
 Address: 9 Belgian Estates
Bruceston Mills WV
26525

Phone #: (304) 379-7789
 Fax #: same
 Email : cpretzel@aol.com

Name : GARY C LEWIS ★
 Company: HAWKEYE SVC LLC
 Address: RT1 Box 201A
TERRA ALTA WV 26764

Phone#: 304 789 6286
 Fax #: 304 789 6286
 Email : Hawkeye a Mountain.net

Name : Robert Bottzel / Gary Tinsley
 Company: Robert Bottzel EXCAVATING
 Address: P.O. Box 635
OAKLAND, MD. 21550

Phone#: 301-334-6326
 Fax #: 301-334-6326
 Email : garyofork@yahoo.com

Name : Breakaway Inc.
 Company: Doug Vincent
 Address: 1075 Old Turn Pike Rd.
SUTTON W.V. 26601

Phone#: (304) 765-5317
 Fax #: 765-5389
 Email : _____

Name : LIME DOSERS CONSULTANTS
 Company: DON STAMM LLC
 Address: ~~190 E. MAIN ST~~
SALEM, WV

Phone#: 304-782-1037
 Fax #: 304-782-2481
 Email : STAMM3@verizon.net

MANDATORY PRE-BID SIGN-IN ATTENDANCE SHEET

RFQ # : 14379
Project: LAUREL RUN DDSEER

Bid Date: 9/9/08
Pre-Bid Date: 8/5/08

Name : GREG PENDERGRASS
Company: PSI
Address: 147 ELEVENTH AVE
SOUTH CHARLESTON
WV 25303
Phone #: 304-389-3360
Fax #: 304-744-3113
Email: GT.PENDERGRASS@AOL.COM

Name : _____
Company: _____
Address: _____
Phone# : _____
Fax # : _____
Email : _____

Name : WALTER Heimbuch
Company: Doddridge Controls, Inc.
Address: RT 2, Box 386
SKINNSTON, WV 26431
Phone #: 304-592-0634
Fax #: 304-592-5350
Email: wheimbuch@Hughes.net

Name : _____
Company: _____
Address: _____
Phone# : _____
Fax # : _____
Email : _____

Name : JOSEPH MILLS
Company: MD BUREAU OF MINES
Address: 160 S. WATER STREET
FROSTBURG MD 21532
Phone #: 301.689.1457
Fax #: 301.689.4566
Email: jmills@allconet.org

- no copies to be sent to him

Name : _____
Company: _____
Address: _____
Phone# : _____
Fax # : _____
Email : _____

Name : _____
Company: _____
Address: _____
Phone #: _____
Fax #: _____
Email : _____

Name : _____
Company: _____
Address: _____
Phone# : _____
Fax # : _____
Email : _____

DEP14379
Addendum #1
Laurel Run Doser Project

The following information is supplementary to the design plans for the project.

- 1) Electric service has been provided to the pole on-site via overhead lines in the previous project. The contractor shall be required to provide the services necessary for installing electric service from the pole underground to the control panel of the doser which will include the wiring, conduit, and electrical connection. The service shall be buried from the pole to the building and shall be installed through the outside wall of the building at a location convenient for connecting to the control panel. Conduit from the pole to the doser pad is not provided by the previous project.
- 2) The Contractor shall be required to provide the services necessary to make the electric connection to the pump in the vault from the control panel. A 2" conduit has been provided by the previous project from the doser pad underground to the vault over the borehole for this purpose.
- 3) The Contractor shall provide the services required for construction of the structural supports needed to hold the silo in place and support the load of the filled silo. The structural support shall consist of four silo posts welded to the sides of the silo and to a 1-inch thick steel bearing plate as shown on the attached drawings. A 12.5 foot x 1.0 foot bearing plate shall be provided by the Contractor and welded to the existing steel pads in the foundation and secured to the foundation by anchor bolts as shown on the Details.

The structural steel shall consist of 8-Inch steel columns weighing a minimum of 31 lbs/ft. All welds shall be performed by a certified welder. The Contractor is responsible for ensuring the structural integrity of the silo support system.

The silo support system shall be constructed in accordance with and to the dimensions shown on the attached diagram. The construction of the steel columns as indicated in the attached drawings necessitates some modification to the design of the attached building. These modifications are shown on the drawings and shall be incorporated into the fabrication of the building.

The cost for materials and labor required for construction of the structural steel support system shall be included in the lump sum price bid for Item 3.0 Doser.

CROSS-SECTION A-A'

SCALE 1" = 4'

N.T.S

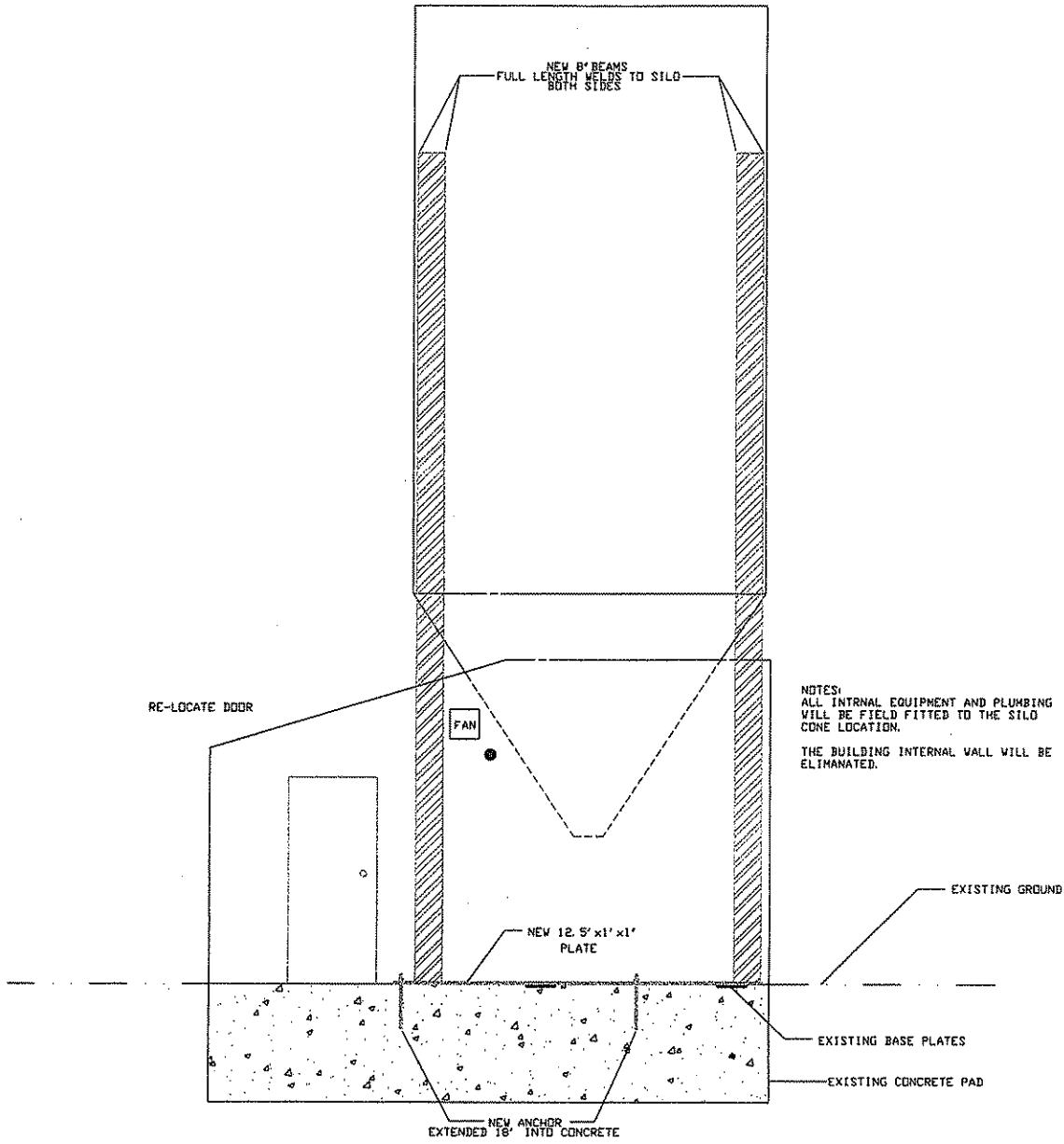

#DEP14379
Laurel Run Doser Project
Addendum #1
08/19/08
DWG #1

CROSS-SECTION B-B'

SCALE 1" = 4'

N.T.S

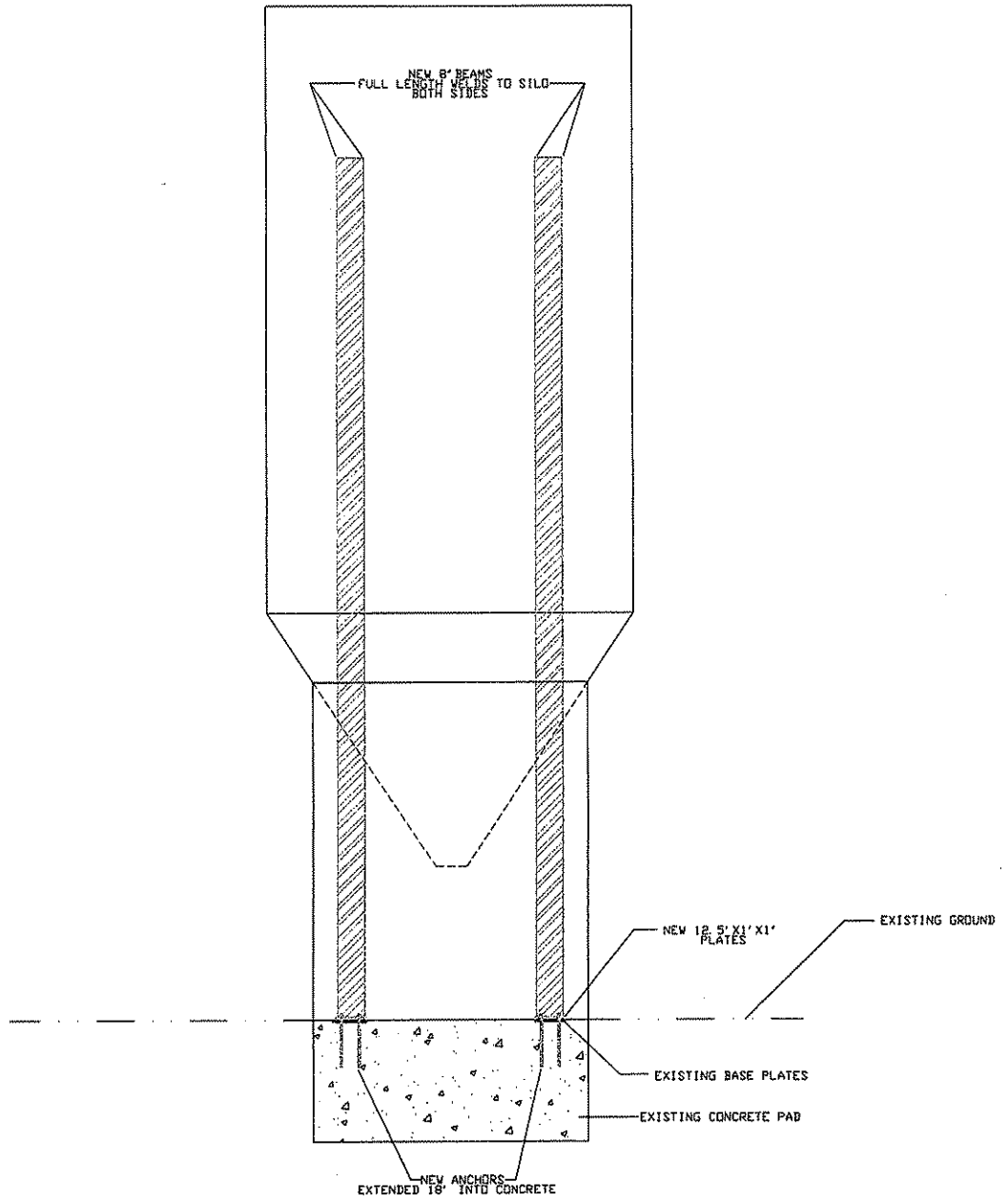

#DEP14379
Laurel Run Doser Project
Addendum #1
08/19/08
DWG #2

PLAN VIEW
SCALE 1"=4'

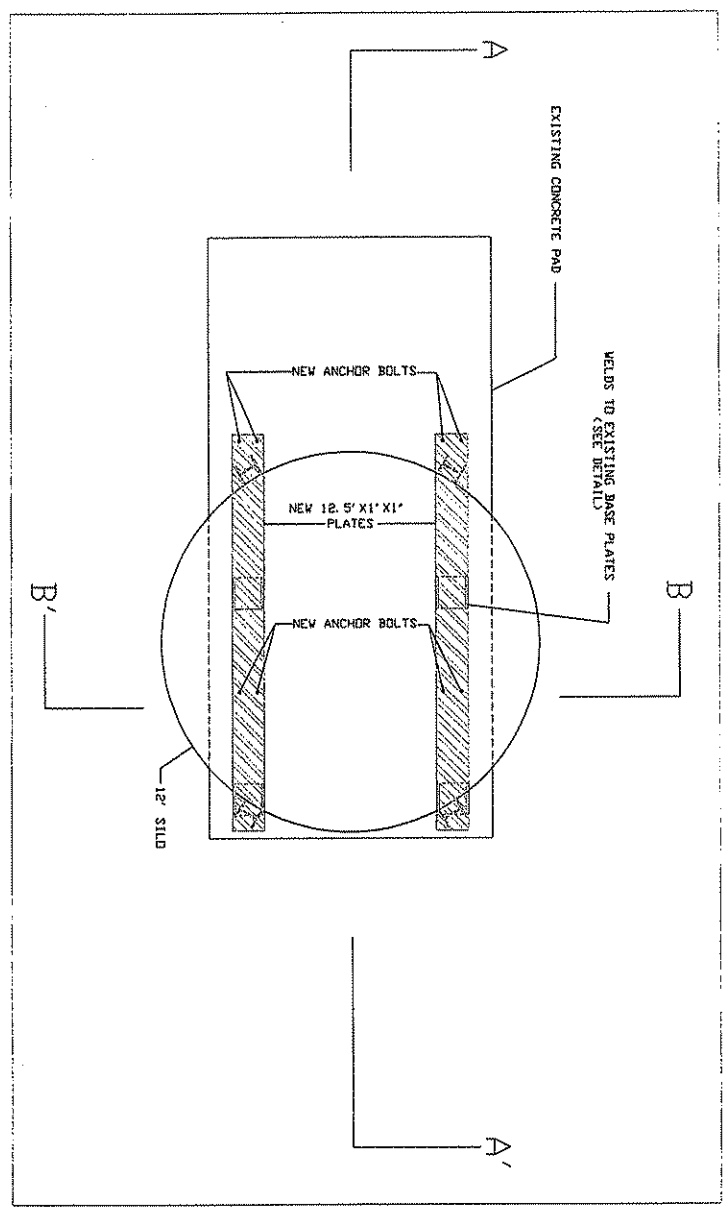

BEARING PLATE DETAIL
SCALE 1"=1'

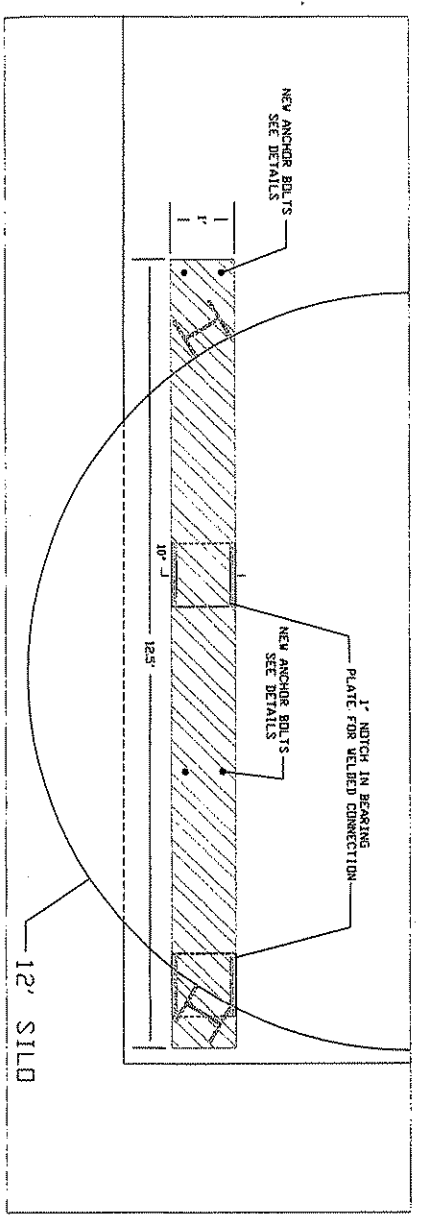

ANCHOR DETAILS
NOT TO SCALE

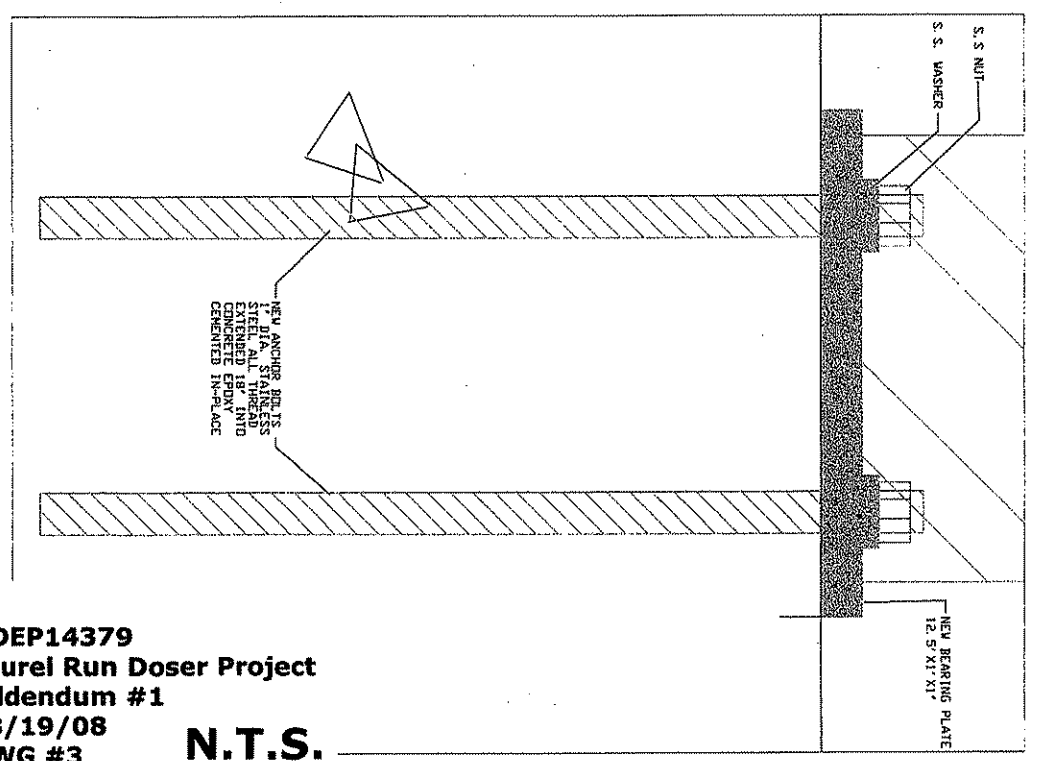

#DEP14379
 Laurel Run Doser Project
 Addendum #1
 08/19/08
 DWG #3
N.T.S.