



State of West Virginia  
 Department of Administration  
 Purchasing Division  
 2019 Washington Street East  
 Post Office Box 50130  
 Charleston, WV 25305-0130

# Request for Quotation

RFQ NUMBER  
**DCH09116**

PAGE  
**1**

ADDRESS CORRESPONDENCE TO ATTENTION OF  
**SHELLY MURRAY  
 304-558-8801**

RFQ COPY  
 TYPE NAME/ADDRESS HERE

**DIVISION OF CULTURE & HISTORY  
 CULTURAL CENTER  
 1900 KANAWHA BOULEVARD, EAST  
 CHARLESTON, WV  
 25305-0300 558-0220**

VENDOR

SHIP TO

DATE PRINTED <b>05/28/2009</b>	TERMS OF SALE	SHIP VIA	FOB	FREIGHT TERMS
-----------------------------------	---------------	----------	-----	---------------

BID OPENING DATE: **06/11/2009** BID OPENING TIME **01:30PM**

LINE	QUANTITY	UOP	CAT NO	ITEM NUMBER	UNIT PRICE	AMOUNT
				RE-BID OF DCH09084		
				<p>THE WEST VIRGINIA PURCHASING DIVISION, FOR THE AGENCY, THE WEST VIRGINIA DIVISION OF CULTURE &amp; HISTORY, IS SOLICITING BIDS FOR A FIRE ALARM AND SPRINKLER UPGRADE AT THE CULTURAL CENTER LOCATED AT THE STATE CAPITOL COMPLEX, 1900 KANAWHA BOULEVARD EAST, CHARLESTON, WV PER THE ATTACHED REVISED INVITATION TO BID, BID CLARIFICATIONS, SKETCHES, AND FORM OF PROPOSAL. THE ORIGINAL PROJECT MANUAL IS TO BE REFERENCED WITH THIS RE-BID WITH EXCEPTION OF THE PREVIOUSLY NOTED BID CLARIFICATIONS, ETC.</p> <p>SUBCONTRACTOR LIST IS NOT TO BE SUBMITTED AT TIME OF BID.</p>		
0001	1	LS		340-20		
				FIRE ALARM/SPRINKLER UPGRADE		
				EXHIBIT 5		
				<p>WEST VIRGINIA CODE 21-1D-5 PROVIDES THAT: ANY SOLICITATION FOR A PUBLIC IMPROVEMENT CONSTRUCTION CONTRACT REQUIRES EACH VENDOR THAT SUBMITS A BID FOR THE WORK TO SUBMIT AT THE SAME TIME AN AFFIDAVIT OF COMPLIANCE WITH THE BID. THE ENCLOSED DRUG-FREE WORKPLACE AFFIDAVIT MUST BE SIGNED AND SUBMITTED WITH THE BID AS EVIDENCE OF THE VENDOR'S COMPLIANCE WITH THE PROVISIONS OF ARTICLE 1D, CHAPTER 21 OF THE WEST VIRGINIA CODE. FAILURE TO SUBMIT THE SIGNED DRUG-FREE WORKPLACE AFFIDAVIT WITH THE BID SHALL RESULT IN DISQUALIFICATION OF SUCH BID.</p>		

SEE REVERSE SIDE FOR TERMS AND CONDITIONS

SIGNATURE	TELEPHONE	DATE
TITLE	FEIN	ADDRESS CHANGES TO BE NOTED ABOVE

WHEN RESPONDING TO RFQ, INSERT NAME AND ADDRESS IN SPACE ABOVE LABELED 'VENDOR'

**GENERAL TERMS & CONDITIONS  
REQUEST FOR QUOTATION (RFQ) AND REQUEST FOR PROPOSAL (RFP)**

1. Awards will be made in the best interest of the State of West Virginia.
2. The State may accept or reject in part, or in whole, any bid.
3. All quotations are governed by the *West Virginia Code* and the *Legislative Rules* of the Purchasing Division.
4. Prior to any award, the apparent successful vendor must be properly registered with the Purchasing Division and have paid the required \$125 fee.
5. All services performed or goods delivered under State Purchase Order/Contracts are to be continued for the term of the Purchase Order/Contracts, contingent upon funds being appropriated by the Legislature or otherwise being made available. In the event funds are not appropriated or otherwise available for these services or goods, this Purchase Order/Contract becomes void and of no effect after June 30.
6. Payment may only be made after the delivery and acceptance of goods or services.
7. Interest may be paid for late payment in accordance with the *West Virginia Code*.
8. Vendor preference will be granted upon written request in accordance with the *West Virginia Code*.
9. The State of West Virginia is exempt from federal and state taxes and will not pay or reimburse such taxes.
10. The Director of Purchasing may cancel any Purchase Order/Contract upon 30 days written notice to the seller.
11. The laws of the State of West Virginia and the *Legislative Rules* of the Purchasing Division shall govern all rights and duties under the Contract, including without limitation the validity of this Purchase Order/Contract.
12. Any reference to automatic renewal is hereby deleted. The Contract may be renewed only upon mutual written agreement of the parties.
13. **BANKRUPTCY:** In the event the vendor/contractor files for bankruptcy protection, the State may deem this contract null and void, and terminate such contract without further order.
14. **HIPAA BUSINESS ASSOCIATE ADDENDUM:** The West Virginia State Government HIPAA Business Associate Addendum (BAA), approved by the Attorney General, and available online at the Purchasing Division's web site (<http://www.state.wv.us/admin/purchase/vrc/hipaa.htm>) is hereby made part of the agreement. Provided that, the Agency meets the definition of a Cover Entity (45 CFR §160.103) and will be disclosing Protected Health Information (45 CFR §160.103) to the vendor.
15. **WEST VIRGINIA ALCOHOL & DRUG-FREE WORKPLACE ACT:** If this Contract constitutes a public improvement construction contract as set forth in Article 1D, Chapter 21 of the West Virginia Code ("The West Virginia Alcohol and Drug-Free Workplace Act"), then the following language shall hereby become part of this Contract: "The contractor and its subcontractors shall implement and maintain a written drug-free workplace policy in compliance with the West Virginia Alcohol and Drug-Free Workplace Act, as set forth in Article 1D, Chapter 21 of the West Virginia Code. The contractor and its subcontractors shall provide a sworn statement in writing, under the penalties of perjury, that they maintain a valid drug-free work place policy in compliance with the West Virginia and Drug-Free Workplace Act. It is understood and agreed that this Contract shall be cancelled by the awarding authority if the Contractor: 1) Fails to implement its drug-free workplace policy; 2) Fails to provide information regarding implementation of the contractor's drug-free workplace policy at the request of the public authority; or 3) Provides to the public authority false information regarding the contractor's drug-free workplace policy."

---

**INSTRUCTIONS TO BIDDERS**

1. Use the quotation forms provided by the Purchasing Division.
2. **SPECIFICATIONS:** Items offered must be in compliance with the specifications. Any deviation from the specifications must be clearly indicated by the bidder. Alternates offered by the bidder as **EQUAL** to the specifications must be clearly defined. A bidder offering an alternate should attach complete specifications and literature to the bid. The Purchasing Division may waive minor deviations to specifications.
3. Complete all sections of the quotation form.
4. Unit prices shall prevail in case of discrepancy.
5. All quotations are considered F.O.B. destination unless alternate shipping terms are clearly identified in the quotation.
6. **BID SUBMISSION:** All quotations must be delivered by the bidder to the office listed below prior to the date and time of the bid opening. Failure of the bidder to deliver the quotations on time will result in bid disqualifications: Department of Administration, Purchasing Division, 2019 Washington Street East, P.O. Box 50130, Charleston, WV 25305-0130



State of West Virginia  
 Department of Administration  
 Purchasing Division  
 2019 Washington Street East  
 Post Office Box 50130  
 Charleston, WV 25305-0130

# Request for Quotation

RFO NUMBER
DCH09116

PAGE
2

ADDRESS CORRESPONDENCE TO ATTENTION OF
SHELLY MURRAY 304-558-8801

RFQ COPY  
 TYPE NAME/ADDRESS HERE

DIVISION OF CULTURE & HISTORY  
 CULTURAL CENTER  
 1900 KANAWHA BOULEVARD, EAST  
 CHARLESTON, WV  
 25305-0300 558-0220

VENDOR

SHIP TO

DATE PRINTED	TERMS OF SALE	SHIP VIA	F.O.B.	FREIGHT TERMS
05/28/2009				

BID OPENING DATE: 06/11/2009 BID OPENING TIME 01:30PM

LINE	QUANTITY	UOP	CAT NO	ITEM NUMBER	UNIT PRICE	AMOUNT
<p><b>NOTICE TO PROCEED:</b> THIS CONTRACT IS TO BE PERFORMED WITHIN 365 CALENDAR DAYS AFTER THE NOTICE TO PROCEED IS RECEIVED. UNLESS OTHERWISE SPECIFIED, THE FULLY EXECUTED PURCHASE ORDER WILL BE CONSIDERED NOTICE TO PROCEED.</p> <p><b>CANCELLATION:</b> THE DIRECTOR OF PURCHASING RESERVES THE RIGHT TO CANCEL THIS CONTRACT IMMEDIATELY UPON WRITTEN NOTICE TO THE VENDOR IF THE MATERIALS OR WORKMANSHIP SUPPLIED ARE OF AN INFERIOR QUALITY OR DO NOT CONFORM WITH THE SPECIFICATIONS OF THE BID AND CONTRACT HERE IN.</p> <p><b>WAGE RATES:</b> THE CONTRACTOR OR SUBCONTRACTOR SHALL PAY THE HIGHER OF THE U.S. DEPARTMENT OF LABOR MINIMUM WAGE RATES AS ESTABLISHED FOR KANAWHA COUNTY, PURSUANT TO WEST VIRGINIA CODE 21-5A, ET, SEQ. (PREVAILING WAGE RATES APPLY TO THIS PROJECT)</p> <p><b>ARBITRATION:</b> ANY REFERENCES MADE TO ARBITRATION OR INTEREST FOR PAYMENTS DUE (EXCEPT FOR ANY INTEREST REQUIRED BY STATE LAW) CONTAINED IN THIS CONTRACT OR IN ANY AMERICAN INSTITUTE OF ARCHITECTS DOCUMENTS PERTAINING TO THIS CONTRACT ARE HEREBY DELETED.</p> <p><b>WORKERS' COMPENSATION:</b> VENDOR IS REQUIRED TO PROVIDE A CERTIFICATE FROM WORKERS' COMPENSATION IF SUCCESSFUL.</p> <p>ALL OF THE ITEMS CHECKED BELOW WILL BE A REQUIREMENT OF THIS CONTRACT:</p> <p>(XX) <b>INSURANCE:</b> SUCCESSFUL VENDOR SHALL FURNISH PROOF OF COMMERCIAL GENERAL LIABILITY INSURANCE PRIOR TO ISSUANCE OF CONTRACT. UNLESS OTHERWISE SPECIFIED IN THE BID DOCUMENTS, THE MINIMUM AMOUNT OF INSURANCE</p>						

SEE REVERSE SIDE FOR TERMS AND CONDITIONS

SIGNATURE	TELEPHONE	DATE
TITLE	FEIN	ADDRESS CHANGES TO BE NOTED ABOVE

WHEN RESPONDING TO RFQ, INSERT NAME AND ADDRESS IN SPACE ABOVE LABELED 'VENDOR'



State of West Virginia  
 Department of Administration  
 Purchasing Division  
 2019 Washington Street East  
 Post Office Box 50130  
 Charleston, WV 25305-0130

# Request for Quotation

RFQ NUMBER  
**DCH09116**

PAGE  
**3**

ADDRESS CORRESPONDENCE TO ATTENTION OF  
**SHELLY MURRAY**  
**304-558-8801**

RFQ COPY  
 TYPE NAME/ADDRESS HERE

**DIVISION OF CULTURE & HISTORY**  
**CULTURAL CENTER**  
**1900 KANAWHA BOULEVARD, EAST**  
**CHARLESTON, WV**  
**25305-0300 558-0220**

VENDOR

SHIP TO

DATE PRINTED	TERMS OF SALE	SHIP VIA	F.O.B.	FREIGHT TERMS
05/28/2009				

BID OPENING DATE: **06/11/2009** BID OPENING TIME **01:30PM**

LINE	QUANTITY	UOP	CAT NO	ITEM NUMBER	UNIT PRICE	AMOUNT
<p>COVERAGE REQUIRED IS \$250,000.</p> <p>( ) BUILDERS RISK INSURANCE: SUCCESSFUL VENDOR SHALL FURNISH PROOF OF BUILDERS RISK - ALL RISK INSURANCE IN AN AMOUNT EQUAL TO 100% OF THE AMOUNT OF THE CONTRACT.</p> <p>(XX) BONDS: FIVE PERCENT (5%) OF THE TOTAL AMOUNT OF THE BID PAYABLE TO THE STATE OF WEST VIRGINIA, SHALL BE SUBMITTED WITH EACH BID AS A BID BOND. THE SUCCESSFUL BIDDER SHALL ALSO FURNISH A PERFORMANCE BOND AND LABOR/MATERIAL BOND FOR 100% OF THE AMOUNT OF THE CONTRACT. BONDS MAY BE PROVIDED IN THE FORM OF A CERTIFIED CHECK IRREVOCABLE LETTER OF CREDIT, OR BOND FURNISHED BY A SOLVENT SURETY COMPANY AUTHORIZED TO DO BUSINESS IN THE STATE OF WEST VIRGINIA. A LETTER OF CREDIT SUBMITTED IN LIEU OF A BOND WILL ONLY BE ALLOWED FOR PROJECTS UNDER \$100,000. PERSONAL OR BUSINESS CHECKS ARE NOT ACCEPABLE IN LIEU OF THE 5% BID BOND, PERFORMANCE BOND, OR LABOR AND MATERIAL BOND.</p> <p>( ) MAINTENANCE BOND: A TWO (2) YEAR MAINTENANCE BOND COVERING THE ROOFING SYSTEM WILL BE A REQUIREMENT OF THE SUCCESSFUL VENDOR.</p> <p>REV. 11/00</p> <p>EXHIBIT 7</p> <p>DOMESTIC ALUMINUM, GLASS &amp; STEEL IN PUBLIC WORKS PROJECTS</p> <p>IN ACCORDANCE WITH WEST VIRGINIA CODE 5-19-1 ET., SEQ., EVERY CONTRACT FOR CONSTRUCTION, RECONSTRUCTION, ALTERATION, REPAIR, IMPROVEMENT OR MAINTENANCE OF PUBLIC WORKS, WHERE THE COST IS MORE THAN \$50,000 AND,</p>						

SEE REVERSE SIDE FOR TERMS AND CONDITIONS

SIGNATURE	TELEPHONE	DATE
TITLE	FEIN	ADDRESS CHANGES TO BE NOTED ABOVE

WHEN RESPONDING TO RFQ, INSERT NAME AND ADDRESS IN SPACE ABOVE LABELED 'VENDOR'



State of West Virginia  
 Department of Administration  
 Purchasing Division  
 2019 Washington Street East  
 Post Office Box 50130  
 Charleston, WV 25305-0130

# Request for Quotation

RFQ NUMBER  
**DCH09116**

PAGE  
**4**

ADDRESS CORRESPONDENCE TO ATTENTION OF  
**SHELLY MURRAY**  
**304-558-8801**

VENDOR

RFQ COPY  
 TYPE NAME/ADDRESS HERE

SHIP TO

DIVISION OF CULTURE & HISTORY  
 CULTURAL CENTER  
 1900 KANAWHA BOULEVARD, EAST  
 CHARLESTON, WV  
 25305-0300 558-0220

DATE PRINTED <b>05/28/2009</b>	TERMS OF SALE	SHIP VIA	F.O.B.	FREIGHT TERMS
-----------------------------------	---------------	----------	--------	---------------

BID OPENING DATE: **06/11/2009** BID OPENING TIME **01:30PM**

LINE	QUANTITY	UOP	CAT NO	ITEM NUMBER	UNIT PRICE	AMOUNT
<p>IN THE CASE OF STEEL ONLY, WHERE THE COST OF STEEL IS MORE THAN \$50,000 OR WHERE MORE THAN 10,000 POUNDS OF STEEL ARE REQUIRED, THE STATE WILL ACCEPT ONLY ALUMINUM GLASS, OR STEEL PRODUCTS PRODUCED IN THE UNITED STATES. IN ADDITION, ITEMS OF MACHINERY OR EQUIPMENT PURCHASED FOR USE AT THE SITE OF PUBLIC WORKS SHALL BE MADE OF DOMESTIC ALUMINUM, GLASS OR STEEL, UNLESS THE COST OF THE PRODUCT IS LESS THAN \$50,000 OR LESS THAN 10,000 POUNDS OF STEEL ARE USED IN PUBLIC WORKS PROJECTS.</p> <p>FOREIGN MADE ALUMINUM, GLASS OR STEEL PRODUCTS MAY BE ACCEPTED ONLY IF THE COST OF DOMESTIC PRODUCTS IS FOUND TO BE UNREASONABLE. SUCH COST IS UNREASONABLE IF IT IS 20% OR MORE HIGHER THAN THE BID PRICE FOR FOREIGN MADE PRODUCTS. IF THE DOMESTIC ALUMINUM, GLASS OR STEEL PRODUCTS TO BE SUPPLIED OR PRODUCED IN A "SUBSTANTIAL LABOR SURPLUS AREA", AS DEFINED BY THE UNITED STATES DEPARTMENT OF LABOR, FOREIGN PRODUCTS MAY BE SUPPLIED ONLY IF DOMESTIC PRODUCTS ARE 30% OR MORE HIGHER IN PRICE THAN THE FOREIGN MADE PRODUCTS.</p> <p>IF, PRIOR TO THE AWARD OF A CONTRACT UNDER THE ABOVE PROVISIONS, THE SPENDING OFFICER OF THE SPENDING UNIT DETERMINES THAT THERE EXISTS A BID FOR LIKE FOREIGN ALUMINUM, GLASS OR STEEL THAT IS REASONABLE AND LOWER THAN THE LOWEST BID DOMESTIC PRODUCTS, THE SPENDING OFFICE MAY REQUEST, IN WRITING, A REEVALUATION AND REDUCTION IN THE LOWEST BID FOR SUCH DOMESTIC PRODUCTS. ALL VENDORS MUST INDICATE IN THEIR BID IF THEY ARE SUPPLYING FOREIGN ALUMINUM, GLASS OR STEEL.</p> <p>REV. 3/88</p> <p>EXHIBIT 9</p>						

SEE REVERSE SIDE FOR TERMS AND CONDITIONS

SIGNATURE	TELEPHONE	DATE
TITLE	FEIN	ADDRESS CHANGES TO BE NOTED ABOVE

WHEN RESPONDING TO RFQ, INSERT NAME AND ADDRESS IN SPACE ABOVE LABELED 'VENDOR'





State of West Virginia  
 Department of Administration  
 Purchasing Division  
 2019 Washington Street East  
 Post Office Box 50130  
 Charleston, WV 25305-0130

# Request for Quotation

RFQ NUMBER  
**DCH09116**

PAGE  
**6**

ADDRESS CORRESPONDENCE TO ATTENTION OF:  
**SHELLY MURRAY**  
**304-558-8801**

VENDOR

**RFQ COPY**  
**TYPE NAME/ADDRESS HERE**

SHIP TO

**DIVISION OF CULTURE & HISTORY**  
**CULTURAL CENTER**  
**1900 KANAWHA BOULEVARD, EAST**  
**CHARLESTON, WV**  
**25305-0300 558-0220**

DATE PRINTED	TERMS OF SALE	SHIP VIA	F.O.B.	FREIGHT TERMS
05/28/2009				

BID OPENING DATE: **06/11/2009** BID OPENING TIME **01:30PM**

LINE	QUANTITY	UOP	CAT. NO.	ITEM NUMBER	UNIT PRICE	AMOUNT
<p>I HEREBY ACKNOWLEDGE RECEIPT OF THE FOLLOWING CHECKED ADDENDUM(S) AND HAVE MADE THE NECESSARY REVISIONS TO MY PROPOSAL, PLANS AND/OR SPECIFICATION, ETC.</p> <p>ADDENDUM NOS.:</p> <p>NO. 1 .....</p> <p>NO. 2 .....</p> <p>NO. 3 .....</p> <p>NO. 4 .....</p> <p>NO. 5 .....</p> <p>I UNDERSTAND THAT FAILURE TO CONFIRM THE RECEIPT OF TH ADDENDUM(S) MAY BE CAUSE FOR REJECTION OF THE BIDS.</p> <p>VENDOR MUST CLEARLY UNDERSTAND THAT ANY VERBAL REPRESENTATION MADE OR ASSUMED TO BE MADE DURING ANY ORAL DISCUSSION HELD BETWEEN VENDOR'S REPRESENTATIVES AND ANY STATE PERSONNEL IS NOT BINDING. ONLY THE INFORMATION ISSUED IN WRITING AND ADDED TO THE SPECIFICATIONS BY AN OFFICIAL ADDENDUM IS BINDING.</p> <p>.....SIGNATURE</p> <p>.....COMPANY</p> <p>.....DATE</p> <p>REV. 11/96</p>						

SEE REVERSE SIDE FOR TERMS AND CONDITIONS

SIGNATURE	TELEPHONE	DATE
TITLE	FEIN	ADDRESS CHANGES TO BE NOTED ABOVE

WHEN RESPONDING TO RFQ, INSERT NAME AND ADDRESS IN SPACE ABOVE LABELED 'VENDOR'



State of West Virginia  
 Department of Administration  
 Purchasing Division  
 2019 Washington Street East  
 Post Office Box 50130  
 Charleston, WV 25305-0130

# Request for Quotation

RFQ NUMBER  
**DCH09116**

PAGE  
**7**

ADDRESS CORRESPONDENCE TO ATTENTION OF  
**SHELLY MURRAY**  
**304-558-8801**

**DIVISION OF CULTURE & HISTORY**  
**CULTURAL CENTER**  
**1900 KANAWHA BOULEVARD, EAST**  
**CHARLESTON, WV**  
**25305-0300 558-0220**

VENDOR

RFQ COPY  
 TYPE NAME/ADDRESS HERE

SHIP TO

DATE PRINTED	TERMS OF SALE	SHIP VIA	F.O.B.	FREIGHT TERMS
05/28/2009				

BID OPENING DATE: **06/11/2009** BID OPENING TIME **01:30PM**

LINE	QUANTITY	UOP	CAT. NO.	ITEM NUMBER	UNIT PRICE	AMOUNT
<b>CONTRACTORS LICENSE</b>						
WEST VIRGINIA STATE CODE 21-11-2 REQUIRES THAT ALL PERSONS DESIRING TO PERFORM CONTRACTING WORK IN THIS STATE MUST BE LICENSED. THE WEST VIRGINIA CONTRACTORS LICENSING BOARD IS EMPOWERED TO ISSUE THE CONTRACTORS LICENSE. APPLICATIONS FOR A CONTRACTORS LICENSE MAY BE MADE BY CONTACTING THE WEST VIRGINIA DIVISION OF LABOR CAPITOL COMPLEX, BUILDING 3, ROOM 319, CHARLESTON, WV 25305. TELEPHONE: (304) 558-7890.						
WEST VIRGINIA STATE CODE 21-11-11 REQUIRES ANY PROSPECTIVE BIDDER TO INCLUDE THE CONTRACTORS LICENSE NUMBER ON THEIR BID.						
BIDDER TO COMPLETE:						
CONTRACTORS NAME: .....						
CONTRACTORS LICENSE NO.: .....						
THE SUCCESSFUL BIDDER WILL BE REQUIRED TO FURNISH A COPY OF THEIR CONTRACTORS LICENSE PRIOR TO ISSUANCE OF A PURCHASE ORDER/CONTRACT						
<b>APPLICABLE LAW</b>						
THE WEST VIRGINIA STATE CODE, PURCHASING DIVISION RULES AND REGULATIONS, AND THE INFORMATION PROVIDED IN THE "REQUEST FOR QUOTATION" ISSUED BY THE PURCHASING DIVISION IS THE SOLE AUTHORITY GOVERNING THIS PROCUREMENT.						
ANY INFORMATION PROVIDED IN SPECIFICATION MANUALS, OR ANY OTHER SOURCE, VERBAL OR WRITTEN, WHICH CONTRADICTS						

SEE REVERSE SIDE FOR TERMS AND CONDITIONS

SIGNATURE	TELEPHONE	DATE
TITLE	FEIN	ADDRESS CHANGES TO BE NOTED ABOVE

WHEN RESPONDING TO RFQ, INSERT NAME AND ADDRESS IN SPACE ABOVE LABELED 'VENDOR'





State of West Virginia  
 Department of Administration  
 Purchasing Division  
 2019 Washington Street East  
 Post Office Box 50130  
 Charleston, WV 25305-0130

# Request for Quotation

RFQ NUMBER  
**DCH09116**

PAGE  
**8**

ADDRESS CORRESPONDENCE TO ATTENTION OF  
**SHELLY MURRAY**  
**304-558-8801**

VENDOR

**RFQ COPY**  
**TYPE NAME/ADDRESS HERE**

SHIP TO

**DIVISION OF CULTURE & HISTORY**  
**CULTURAL CENTER**  
**1900 KANAWHA BOULEVARD, EAST**  
**CHARLESTON, WV**  
**25305-0300 558-0220**

DATE PRINTED	TERMS OF SALE	SHIP VIA	FOB	FREIGHT TERMS
05/28/2009				

BID OPENING DATE: **06/11/2009** BID OPENING TIME **01:30PM**

LINE	QUANTITY	UOP	CAT NO.	ITEM NUMBER	UNIT PRICE	AMOUNT
<p>OR ALTERS THE INFORMATION PROVIDED FROM THE SOURCES AS DESCRIBED IN THE ABOVE PARAGRAPH IS VOID AND OF NO EFFECT.</p> <p><b>BANKRUPTCY: IN THE EVENT THE VENDOR/CONTRACTOR FILES FOR BANKRUPTCY PROTECTION, THE STATE MAY DEEM THE CONTRACT NULL AND VOID, AND TERMINATE SUCH CONTRACT WITHOUT FURTHER ORDER.</b></p> <p>REV. 5/2009</p> <p style="text-align: center;"><b>NOTICE</b></p> <p><b>A SIGNED BID MUST BE SUBMITTED TO:</b></p> <p style="text-align: center;"><b>DEPARTMENT OF ADMINISTRATION          PURCHASING DIVISION          BUILDING 15          2019 WASHINGTON STREET, EAST          CHARLESTON, WV 25305-0130</b></p> <p><b>THE BID SHOULD CONTAIN THIS INFORMATION ON THE FACE OF THE ENVELOPE OR THE BID MAY NOT BE CONSIDERED:</b></p> <p><b>SEALED BID</b></p> <p><b>BUYER: SHELLY MURRAY</b></p> <p><b>REQ. NO.: DCH09116</b></p> <p><b>BID OPENING DATE: 06/11/2009</b></p> <p><b>BID OPENING TIME: 1:30 PM</b></p>						

SEE REVERSE SIDE FOR TERMS AND CONDITIONS

SIGNATURE	TELEPHONE	DATE
TITLE	FEIN	ADDRESS CHANGES TO BE NOTED ABOVE

WHEN RESPONDING TO RFQ, INSERT NAME AND ADDRESS IN SPACE ABOVE LABELED 'VENDOR'



State of West Virginia  
 Department of Administration  
 Purchasing Division  
 2019 Washington Street East  
 Post Office Box 50130  
 Charleston, WV 25305-0130

# Request for Quotation

RFQ NUMBER  
**DCH09116**

PAGE  
**9**

ADDRESS CORRESPONDENCE TO ATTENTION OF  
**SHELLY MURRAY**  
**304-558-8801**

RFQ COPY  
 TYPE NAME/ADDRESS HERE

**DIVISION OF CULTURE & HISTORY**  
**CULTURAL CENTER**  
**1900 KANAWHA BOULEVARD, EAST**  
**CHARLESTON, WV**  
**25305-0300 558-0220**

V  
E  
N  
D  
O  
R

S  
H  
I  
P  
T  
O

DATE PRINTED	TERMS OF SALE	SHIP VIA	F.O.B.	FREIGHT TERMS
05/28/2009				

BID OPENING DATE: **06/11/2009** BID OPENING TIME **01:30PM**

LINE	QUANTITY	UOP	CAT. NO.	ITEM NUMBER	UNIT PRICE	AMOUNT
PLEASE PROVIDE A FAX NUMBER IN CASE IT IS NECESSARY TO CONTACT YOU REGARDING YOUR BID: ----- PLEASE PRINT OR TYPE NAME OF PERSON TO CONTACT CONCERNING THIS QUOTE: -----  ***** THIS IS THE END OF RFQ DCH09116 ***** TOTAL: _____						

SEE REVERSE SIDE FOR TERMS AND CONDITIONS

SIGNATURE	TELEPHONE	DATE
TITLE	FEIN	ADDRESS CHANGES TO BE NOTED ABOVE

WHEN RESPONDING TO RFQ, INSERT NAME AND ADDRESS IN SPACE ABOVE LABELED 'VENDOR'

## INVITATION TO BID

**West Virginia Department of Administration Purchasing Division** located in Charleston, WV invites proposals to provide all Work, including but not limited to labor, material, equipment supplies and transportation for:

**WV Division of Culture & History  
Cultural Center  
Fire Alarm/ Sprinkler Upgrades  
State Capitol Complex  
1900 Kanawha Blvd. East  
Charleston, WV 25305**

### BID PACKAGE FOR FIRE ALARM / SPRINKLER UPGRADES

All Bids must be submitted in accordance with the Specifications and Constructions Drawings dated March 11, 2009 – available from Charleston Blueprint for \$250.00 per set – and structural drawings provided as part of the Request for Quotations but also available from the Owner. Refer to advertisement for specific information in obtaining construction documents. Only complete sets will be issued.

**Sealed Bids will be received by the State of West Virginia Department of Administration Purchasing Division. Please see advertisement for time, location & date** in accordance with the Instructions to Bidders and the Supplementary Instructions to Bidders. Provide one original and copies as required by the Owner to State of West Virginia Department of Administration Purchasing Division.

#### ORIGINAL SIGNED BID TO:

**State of West Virginia  
Department of Administration  
Purchasing Division  
2019 Washington Street East  
Post Office Box 50130  
Charleston, WV 25305-0130**

The Owner reserves the right to accept or reject any or all bids. The Owner intends to select the successful bidder or reject all bids within sixty days of receipt of bids. **The construction schedules shall be based on having notice to proceed given no later than sixty days after bid opening. The contractor may proceed prior to that date if awarded earlier.**

\*See Advertisement for additional instructions to bidders.

**DCH09116****BID CLARIFICATIONS**

1. Sketches "A1 and A2": ZDS received drawings dated 4/14/09 for an area of renovations that will have a minor impact on this project. See attached sketches.
2. The successful bidder on this project will be responsible for coordination of the Fire Alarm and Fire Protection Sprinkler work in the renovated area. Any modifications required for complete and operable systems will be included in this Contractor's Bid at no additional cost to the Owner.
3. This contractor shall **not** be required to perform the work in rooms #253 & #255 as follows:
  - 1) Demolition work per plan notes 1 & 2 on Dwg. D1.
  - 2) Ceiling, lighting etc. Work per plan notes 1 through 5 on Dwg. FA1.
  - 3) This Work is being performed under separate Contract by Others.
4. Proposal shall be based on the Fire Alarm system as indicated on the drawings and in the specifications. The intent is that only one (1) Fire Alarm system shall be installed and maintained throughout the facility for 100% compatibility.
5. Factory painted red conduit may be used in lieu of the red color banding added to standard grey conduit as mentioned in specification #16050, 3.6 D.
6. In room #201 the existing shelving is built-in and cannot be removed. The loose furniture will be moved by the Cultural Center staff. Man-lifts may be used in these areas; Contractor is responsible for protection of the floor; any damages to the floor, etc, as a result of Contractor's work shall be repaired or replaced at the satisfaction of the Owner at no additional cost to the Owner.
7. There is no freight elevator available with removable panel for transport of materials; however, there is a path to get to the upper areas. Contractor shall field verify pathway.
8. Limited parking will be made available to the contractor's superintendent and necessary supply vehicles. Individual workers will need to make other arrangements. This issue will be addressed in more detail during the pre-construction meeting.
9. Painting of sprinkler piping will not be required in non-public spaces.
10. Drawings FP3 and FP4, Detail section "A-A" shows pendent mounted heads. Sprinkler heads in these areas **must be** upright type. Note that all piping must be installed with proper pitch to drain.

11. Drawing FP2: In rooms #201 and #252 provide coverage as needed where soffits obstruct the overhead sprinklers. Piping can be routed on top of the soffits with penetrations to below for proper protection.
12. Drawing FA2: Add one (1) smoke detector in alcove #300 for the pre-action system.
13. Existing items, surfaces to remain that are damaged during the work of this Contractor shall be replaced, repaired or refinished to the satisfaction of the Owner at no additional cost to the Owner.
14. Loose furnishings, materials etc. that require moving for the work shall be coordinated with the Owner at least 24 hours in advance. Owners' personnel shall move these items.

**Enclosed: Sketches "A1" & "A2" – 2 pages**

### DOOR SCHEDULE

NO.	SYM.	SIZE	DOOR	GLASS	SWING	FINISH	MARK	GLASS	MARK	GLASS	MARK	GLASS	MARK	GLASS	MARK	GLASS	MARK
101		3'-0" x 7'-0"	SW	0	INT	0											
102		3'-0" x 7'-0"	SW	0	INT	0											
103		3'-0" x 7'-0"	SW	0	INT	0											
104		3'-0" x 7'-0"	SW	0	INT	0											
105		3'-0" x 7'-0"	SW	0	INT	0											
106		3'-0" x 7'-0"	SW	0	INT	0											
107		3'-0" x 7'-0"	SW	0	INT	0											
108		3'-0" x 7'-0"	SW	0	INT	0											
109		3'-0" x 7'-0"	SW	0	INT	0											
110		3'-0" x 7'-0"	SW	0	INT	0											
111		3'-0" x 7'-0"	SW	0	INT	0											
112		3'-0" x 7'-0"	SW	0	INT	0											
113		3'-0" x 7'-0"	SW	0	INT	0											
114		3'-0" x 7'-0"	SW	0	INT	0											
115		3'-0" x 7'-0"	SW	0	INT	0											
116		3'-0" x 7'-0"	SW	0	INT	0											
117		3'-0" x 7'-0"	SW	0	INT	0											
118		3'-0" x 7'-0"	SW	0	INT	0											
119		3'-0" x 7'-0"	SW	0	INT	0											
120		3'-0" x 7'-0"	SW	0	INT	0											

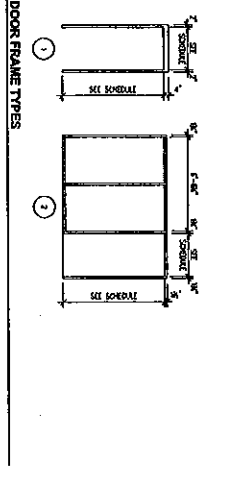
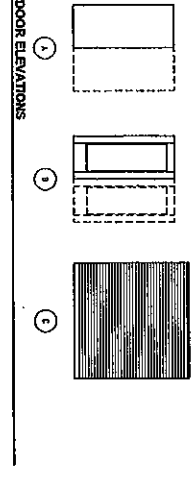

### ◇ TOILET ACCESSORIES SCHEDULE

SYMBOL	DESCRIPTION	MODEL NUMBER	QUANTITY	MARKING HEIGHT (FT)	NOTES
◇	3" CHAIR SEAT	48-000A	1	36" TO CENTER	1 1/2" FROM EDGE
◇	4" CHAIR SEAT	48-000B	1	36" TO CENTER	1 1/2" FROM EDGE
◇	CONCRETE WALL MOUNT TOILET BRACKET	58-000	1	36" TO CENTER	
◇	WALL MOUNT TOILET BRACKET	58-000	1	36" TO CENTER	
◇	WALL MOUNT TOILET BRACKET	58-000	1	36" TO CENTER	
◇	WALL MOUNT TOILET BRACKET	58-000	1	36" TO CENTER	
◇	WALL MOUNT TOILET BRACKET	58-000	1	36" TO CENTER	
◇	WALL MOUNT TOILET BRACKET	58-000	1	36" TO CENTER	
◇	WALL MOUNT TOILET BRACKET	58-000	1	36" TO CENTER	
◇	WALL MOUNT TOILET BRACKET	58-000	1	36" TO CENTER	

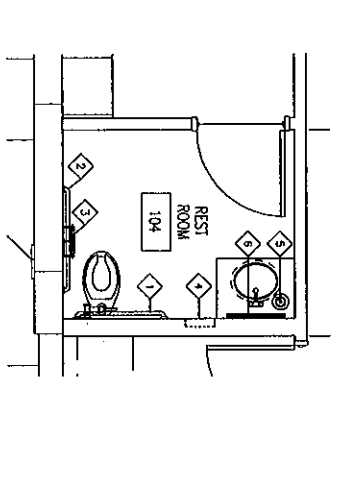

- ### KEYED NOTES
1. WOODWORK: ASBESTOS REMOVAL BY HANDING. FINISH TO BE 1/2" x 1/2" x 1/2" AND BE COULD NEED TO PROTECT ASBESTOS. WALL COLOR MATCH EXISTING.
  2. WOODWORK: FINISH TO BE SELECTED BY PROJECT TEAM MANUFACTURERS. TOU FINISH.
  3. WOODWORK: FINISH TO BE SELECTED BY PROJECT TEAM MANUFACTURERS. TOU FINISH.
  4. WOODWORK: FINISH TO BE SELECTED BY PROJECT TEAM MANUFACTURERS. TOU FINISH.
  5. WOODWORK: FINISH TO BE SELECTED BY PROJECT TEAM MANUFACTURERS. TOU FINISH.
  6. WOODWORK: FINISH TO BE SELECTED BY PROJECT TEAM MANUFACTURERS. TOU FINISH.
  7. WOODWORK: FINISH TO BE SELECTED BY PROJECT TEAM MANUFACTURERS. TOU FINISH.
  8. WOODWORK: FINISH TO BE SELECTED BY PROJECT TEAM MANUFACTURERS. TOU FINISH.
  9. WOODWORK: FINISH TO BE SELECTED BY PROJECT TEAM MANUFACTURERS. TOU FINISH.
  10. WOODWORK: FINISH TO BE SELECTED BY PROJECT TEAM MANUFACTURERS. TOU FINISH.
  11. WOODWORK: FINISH TO BE SELECTED BY PROJECT TEAM MANUFACTURERS. TOU FINISH.
  12. WOODWORK: FINISH TO BE SELECTED BY PROJECT TEAM MANUFACTURERS. TOU FINISH.
  13. WOODWORK: FINISH TO BE SELECTED BY PROJECT TEAM MANUFACTURERS. TOU FINISH.
  14. WOODWORK: FINISH TO BE SELECTED BY PROJECT TEAM MANUFACTURERS. TOU FINISH.
  15. WOODWORK: FINISH TO BE SELECTED BY PROJECT TEAM MANUFACTURERS. TOU FINISH.
  16. WOODWORK: FINISH TO BE SELECTED BY PROJECT TEAM MANUFACTURERS. TOU FINISH.
  17. WOODWORK: FINISH TO BE SELECTED BY PROJECT TEAM MANUFACTURERS. TOU FINISH.
  18. WOODWORK: FINISH TO BE SELECTED BY PROJECT TEAM MANUFACTURERS. TOU FINISH.
  19. WOODWORK: FINISH TO BE SELECTED BY PROJECT TEAM MANUFACTURERS. TOU FINISH.
  20. WOODWORK: FINISH TO BE SELECTED BY PROJECT TEAM MANUFACTURERS. TOU FINISH.

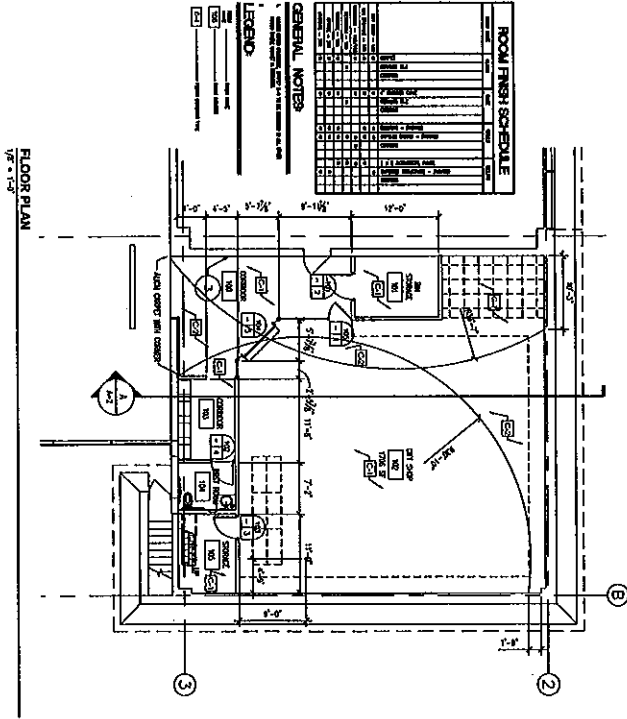
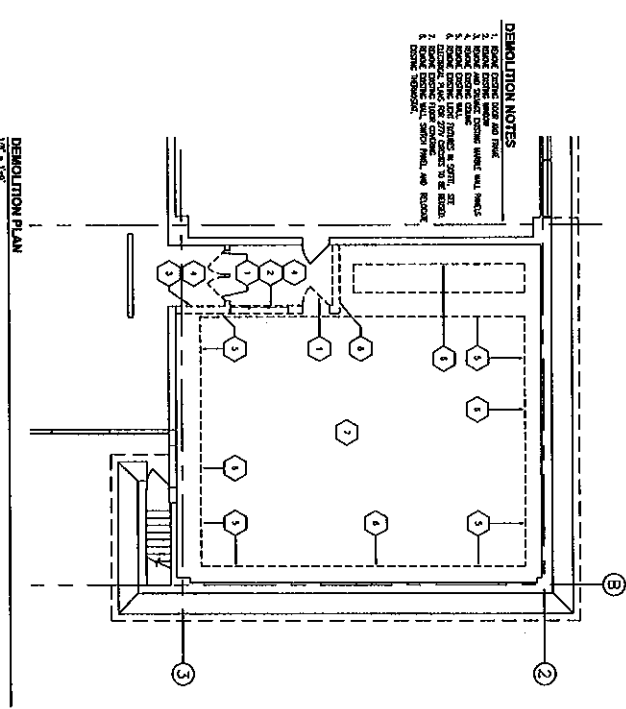
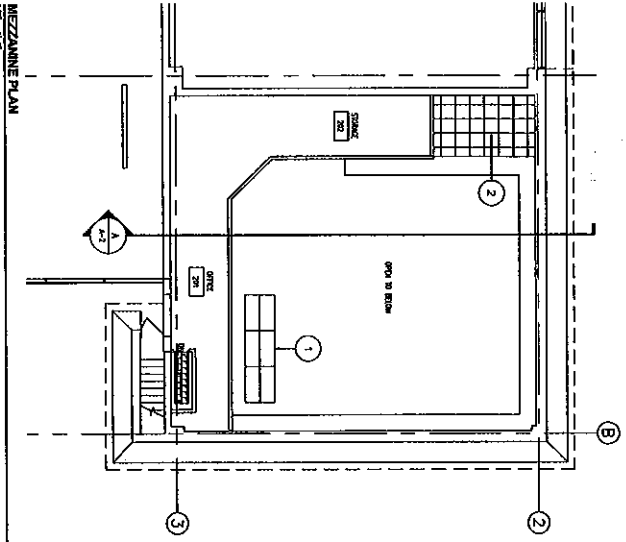

**REVISIONS**

NO.	DATE	DESCRIPTION

**ZMM**  
ARCHITECTS & ENGINEERS

2201 Lee Street, Wheel  
Charleston, West Virginia 25302  
Phone: 304.526.8710  
Fax: 304.526.5144  
www.zmm.com

**DEMOLITION PLAN**  
FLOOR PLANS  
SCHEDULES

DATE: 04/14/09  
DRAWN: BUE  
CHECKED: BUE  
CONTRACT NO.: 18335

**Renovations for the STATE MUSEUM SHOP WEST VIRGINIA CULTURAL CENTER Charleston, West Virginia**

**Construction Documents**

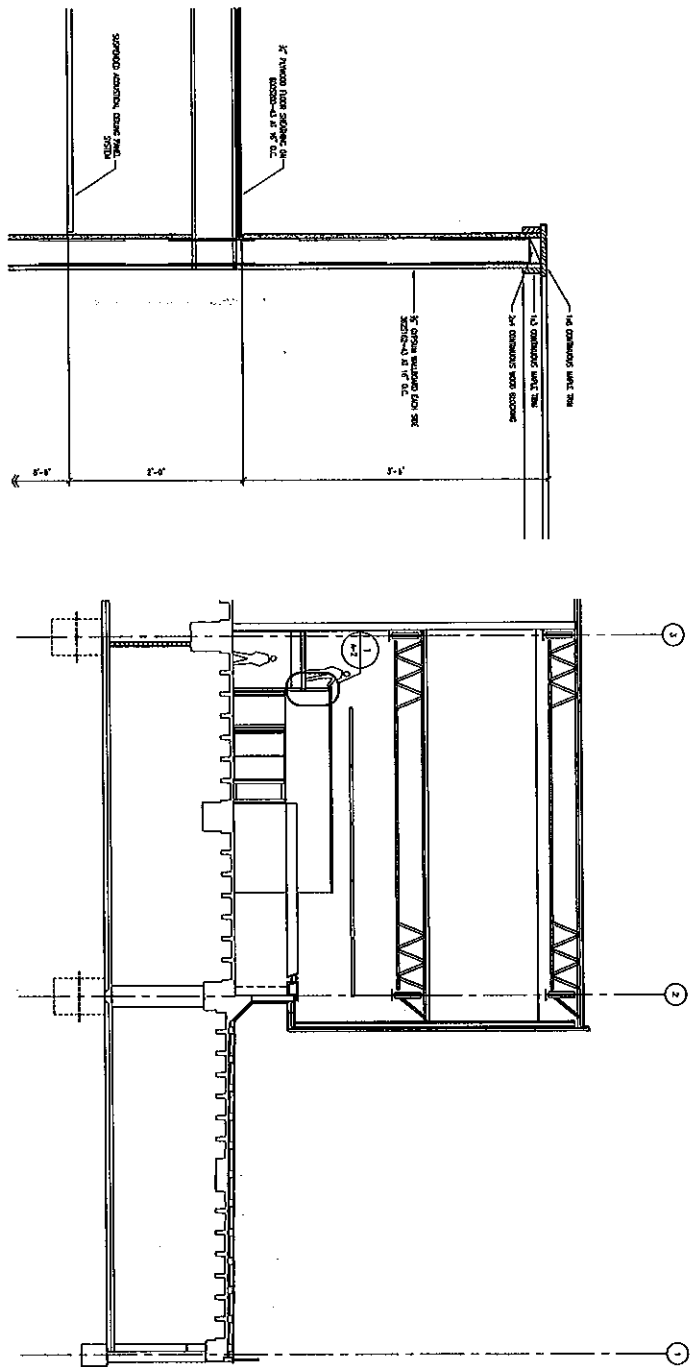

SECTION  
DETAILS

CHECKED  
SRS  
DATE  
04/14/09  
CONTRACT NO.  
0315

PROJECT NO.  
2008-0014

## Renovations for the STATE MUSEUM SHOP WEST VIRGINIA CULTURAL CENTER Charleston, West Virginia

Construction Documents

**ZMM**  
ARCHITECTS & ENGINEERS  
223 Lew Street, West  
Charleston, West Virginia 25302  
Phone: 304.542.0755  
Fax: 304.542.0744  
www.zmm.com

REVISIONS		DESCRIPTION
NO.	DATE	

A-2

DCH09116

## FORM OF PROPOSAL

**OWNER:** West Virginia Division of Culture & History  
Charleston, WV

**PROJECT:** Cultural Center: Fire Alarm/ Sprinkler Upgrades, Charleston, WV

The undersigned, hereinafter called the Bidder, being familiar with and understanding the Bidding Documents and also having examined the site and being familiar with all local conditions affecting the Project, hereby proposes to furnish all labor, material, equipment, supplies and transportation, and to perform all Work in accordance with the Bidding Documents for the sum of:

**BASE BID:** \_\_\_\_\_

\_\_\_\_\_ \$ \_\_\_\_\_

(Bid amount shall be shown in both words and numbers. In the event of a difference between the written amount and the number amount, the written amount shall prevail.)

***UNIT PRICES: FOR FURTHER DETAILS REFER TO SPECIFICATIONS***

<u>Item No. 1</u> – Pull Station	Each \$ _____
<u>Item No. 2</u> – Strobe	Each \$ _____
<u>Item No. 3</u> – Speaker Strobe	Each \$ _____
<u>Item No. 4</u> – Combination Heat Detector	Each \$ _____
<u>Item No. 5</u> – Smoke Detector	Each \$ _____
<u>Item No. 6</u> – Flow or Tamper Switch Connector	Each \$ _____
<u>Item No. 7</u> – One Control Relay	Each \$ _____
<u>Item No. 8</u> – Duct Smoke Detector	Each \$ _____
<u>Item No. 9</u> – Monitor Module	Each \$ _____



RESPECTFULLY SUBMITTED:

SIGNATURE: \_\_\_\_\_ DATE: \_\_\_\_\_

NAME: \_\_\_\_\_

FIRM NAME: \_\_\_\_\_

FIRM ADDRESS: \_\_\_\_\_ *Corporate Seal  
if Applicable*

\_\_\_\_\_  
\_\_\_\_\_

TELEPHONE: \_\_\_\_\_

CONTRACT TIME: \_\_\_\_\_

Contractor's License Number: \_\_\_\_\_

The successful Bidding Contractor agrees that from the compensation otherwise to be paid, the Owner may retain a sum in accordance with the following schedule for each day thereafter, Sundays and holidays included, that the work remains uncompleted, which sum is agreed upon as the proper measure of liquidated damages which the Owner will sustain per diem by the failure of the contractor to complete the work at the stipulated time, and the sum is not to be construed in any sense a penalty. The successful Bidder also shall pay any additional fees that the Engineer and the Engineer's consultants may accrue.

**LIQUIDATED DAMAGES WILL BE ASSESSED AS FOLLOWS:**

\$750.00/per day

The Owner will suffer financial loss if the Work is not Substantially Complete within the Contract Time. Allowance may be made for delays due to shortages of materials and/or energy resources, subject to proof by documentation, and also for delays due to strikes or other delays beyond the control of the Contractor. All delays and any claim for extension of the Contract Time must be properly documented in accordance with the Contract Documents by the Contractor and approved by the Engineer/Owner.

**AUTHORITY AND RESPONSIBILITY OF THE ENGINEER:**

The Engineer shall decide any and all questions that may arise as to the quality and acceptability of materials furnished, work performed, rate of progress of work, interpretation of drawings and specifications and all questions as to the acceptable fulfillment of the contract on the part of the contractor.

**SUCCESSORS AND ASSIGNS:**

This Agreement and all of the covenants hereof shall inure to the benefit of and be binding upon the Owner and the Contractor respectively and his partners, successors, assigns and legal representatives. Neither the Owner nor the Contractor shall have the right to assign, transfer or sublet his interests or obligations hereunder without consent of the other party.

**ADDENDA ACKNOWLEDGMENT**

The undersigned hereby acknowledges receipt of the following Addenda and has taken the information contained therein into full consideration in the formulation of this bid.

Addenda No. 1 \_\_\_\_\_

Addenda No. 2 \_\_\_\_\_

Addenda No. 3 \_\_\_\_\_

Addenda No. 4 \_\_\_\_\_

Failure to acknowledge receipt of each Addendum may be cause for rejection of the bid.

SIGNATURE: \_\_\_\_\_

Signature in Ink

DATE: \_\_\_\_\_

***BIDDER'S CERTIFICATION***

The Bidder hereby acknowledges that the following representations in this Proposal are material and not mere recitals:

1. Bidder has read and understands the Contract Documents and agrees to comply with all requirements of the Contract Documents, regardless of whether the Bidder has actual knowledge of the requirements and regardless of any statement or omission made by the Bidder, which might indicate a contrary intention.
2. The Bidder represents that the Proposal is based upon the Standards specified by the Contract Documents.
3. Bidder has visited the site, has become familiar with local conditions and has correlated personal observations about the requirements of the Contract Documents. The Bidder has no outstanding questions regarding the interpretation of the Contract Documents.
4. The Bidder shall make a good faith effort to ensure that all the Bidder employees, while working on Owner's property, shall not purchase, transfer, use or possess tobacco products, illegal drugs, alcohol, abuse prescription drugs in any way.

5. Bidder agrees to furnish any information requested by the Owner/Engineer to evaluate the responsibility of the Bidder.
6. The Bidder and each person signing on behalf of the Bidder certifies, and in the case of a joint Proposal, each party thereto certifies as to such party's organization, under penalty of perjury, that to the best of the undersigned's knowledge and belief:
  - 6.1 The Proposal has been prepared independently without collusion, consultation, communication or agreement, for the purpose of restricting competition as to any matter relating to such Proposal.
  - 6.2 Unless otherwise required by law, the costs, which have been quoted in the Proposal, have not been knowingly disclosed by the Bidder and will not knowingly be disclosed by the Bidder prior to the Proposal deadline, directly or indirectly, to any other Bidder that would have any interest in the Proposal costs.
  - 6.3 No attempt has been made or will be made by the Bidder to induce any other individual, partnership or corporation to submit or not to submit a Proposal for the purpose of restricting competition.

The successful bidder will be required to furnish a copy of their Contractor's License prior to issuance of a Purchase Order/Contract.

STATE OF WEST VIRGINIA  
Purchasing Division

## PURCHASING AFFIDAVIT

### VENDOR OWING A DEBT TO THE STATE:

**West Virginia Code §5A-3-10a** provides that: No contract or renewal of any contract may be awarded by the state or any of its political subdivisions to any vendor or prospective vendor when the vendor or prospective vendor or a related party to the vendor or prospective vendor is a debtor and the debt owed is an amount greater than one thousand dollars in the aggregate.

### PUBLIC IMPROVEMENT CONTRACTS & DRUG-FREE WORKPLACE ACT:

If this is a solicitation for a public improvement construction contract, the vendor, by its signature below, affirms that it has a written plan for a drug-free workplace policy in compliance with Article 1D, Chapter 21 of the **West Virginia Code**. The vendor **must** make said affirmation with its bid submission. Further, public improvement construction contract may not be awarded to a vendor who does not have a written plan for a drug-free workplace policy in compliance with Article 1D, Chapter 21 of the **West Virginia Code** and who has not submitted that plan to the appropriate contracting authority in timely fashion. For a vendor who is a subcontractor, compliance with Section 5, Article 1D, Chapter 21 of the **West Virginia Code** may take place before their work on the public improvement is begun.

### ANTITRUST:

In submitting a bid to any agency for the state of West Virginia, the bidder offers and agrees that if the bid is accepted the bidder will convey, sell, assign or transfer to the state of West Virginia all rights, title and interest in and to all causes of action it may now or hereafter acquire under the antitrust laws of the United States and the state of West Virginia for price fixing and/or unreasonable restraints of trade relating to the particular commodities or services purchased or acquired by the state of West Virginia. Such assignment shall be made and become effective at the time the purchasing agency tenders the initial payment to the bidder.

I certify that this bid is made without prior understanding, agreement, or connection with any corporation, firm, limited liability company, partnership or person or entity submitting a bid for the same materials, supplies, equipment or services and is in all respects fair and without collusion or fraud. I further certify that I am authorized to sign the certification on behalf of the bidder or this bid.

### LICENSING:

Vendors must be licensed and in good standing in accordance with any and all state and local laws and requirements by any state or local agency of West Virginia, including, but not limited to, the West Virginia Secretary of State's Office, the West Virginia Tax Department, West Virginia Insurance Commission, or any other state agencies or political subdivision. Furthermore, the vendor must provide all necessary releases to obtain information to enable the Director or spending unit to verify that the vendor is licensed and in good standing with the above entities.

### CONFIDENTIALITY:

The vendor agrees that he or she will not disclose to anyone, directly or indirectly, any such personally identifiable information or other confidential information gained from the agency, unless the individual who is the subject of the information consents to the disclosure in writing or the disclosure is made pursuant to the agency's policies, procedures and rules. Vendor further agrees to comply with the Confidentiality Policies and Information Security Accountability Requirements, set forth in <http://www.state.wv.us/admin/purchase/privacy/noticeConfidentiality.pdf>.

Under penalty of law for false swearing (**West Virginia Code §61-5-3**), it is hereby certified that the vendor affirms and acknowledges the information in this affidavit and is in compliance with the requirements as stated.

Vendor's Name: \_\_\_\_\_

Authorized Signature: \_\_\_\_\_ Date: \_\_\_\_\_



State of West Virginia  
DRUG FREE WORKPLACE CONFORMANCE AFFIDAVIT  
West Virginia Code §21-1D-5

STATE OF WEST VIRGINIA,

COUNTY OF \_\_\_\_\_, TO-WIT:

I, \_\_\_\_\_, after being first duly sworn, depose and state as follows:

- 1. I am an employee of \_\_\_\_\_; and,  
(Company Name)
- 2. I do hereby attest that \_\_\_\_\_  
(Company Name)

maintains a valid written drug free workplace policy and that such policy is in compliance with **West Virginia Code** §21-1D-5.

The above statements are sworn to under the penalty of perjury.

\_\_\_\_\_  
(Company Name)

By: \_\_\_\_\_

Title: \_\_\_\_\_

Date: \_\_\_\_\_

Taken, subscribed and sworn to before me this \_\_\_\_\_ day of \_\_\_\_\_.

By Commission expires \_\_\_\_\_

(Seal)

\_\_\_\_\_  
(Notary Public)

**THIS AFFIDAVIT MUST BE SUBMITTED WITH THE BID IN ORDER TO COMPLY WITH WV CODE PROVISIONS. FAILURE TO INCLUDE THE AFFIDAVIT WITH THE BID SHALL RESULT IN DISQUALIFICATION OF THE BID.**

BID BOND PREPARATION INSTRUCTIONS

AGENCY (A)
RFQ/RFP# (B)

Bid Bond

- (A) WV State Agency (Stated on Page 1 "Spending Unit") Request for Quotation Number (upper right corner of page #1)
(C) Your Company Name
(D) City, Location of your Company
(E) State, Location of your Company
(F) Surety Corporate Name
(G) City, Location of Surety
(H) State, Location of Surety
(I) State of Surety Incorporation
(J) City of Surety Incorporation
(K) Minimum amount of acceptable bid bond is 5% of total bid. You may state "5% of bid" or a specific amount on this line in words.
(L) Amount of bond in figures
(M) Brief Description of scope of work
(N) Day of the month
(O) Month
(P) Year
(Q) Name of Corporation
(R) Raised Corporate Seal of Principal
(S) Signature of President or Vice President
(T) Title of person signing
(U) Raised Corporate Seal of Surety
(V) Corporate Name of Surety
(W) Signature of Attorney in Fact of the Surety

KNOW ALL MEN BY THESE PRESENTS, That we, the undersigned, (C) of (D), (E), as Principal, and (F) of (G), (H), a corporation organized and existing under the laws of the State of (I) with its principal office in the City of (J), as Surety, are held and firmly bound unto The State of West Virginia, as Oblige, in the penal sum of (K) (\$ (L)) for the payment of which, well and truly to be made, we jointly and severally bind ourselves, our heirs, administrators, executors, successors and assigns.

The Condition of the above obligation is such that whereas the Principal has submitted to the Purchasing Section of the Department of Administration a certain bid or proposal, attached hereto and made a part hereof to enter into a contract in writing for (M)

NOW THEREFORE.

- (a) If said bid shall be rejected, or
(b) If said bid shall be accepted and the Principal shall enter into a contract in accordance with the bid or proposal attached hereto and shall furnish any other bonds and insurance required by the bid or proposal, and shall in all other respects perform the agreement created by the acceptance of said bid then this obligation shall be null and void, otherwise this obligation shall remain in full force and effect. It is expressly understood and agreed that the liability of the Surety for any and all claims hereunder shall, in no event, exceed the penal amount of this obligation as herein stated

The Surety for value received, hereby stipulates and agrees that the obligations of said Surety and its bond shall be in no way impaired or affected by any extension of time within which the Oblige may accept such bid: and said Surety does hereby waive notice of any such extension.

IN WITNESS WHEREOF, Principal and Surety have hereunto set their hands and seals, and such of them as are corporations have caused their corporate seals to be affixed hereto and these presents to be signed by their proper officers, this (N) day of (O), 20 (P).

Principal Corporate Seal (R) By (Q) (Name of Principal) (S) (Must be President or Vice President) (T) Title

Surety Corporate Seal (U) (V) (Name of Surety)

(W) Attorney-in-Fact

IMPORTANT - Surety executing bonds must be licensed in West Virginia to transact surety insurance. Raised Corporate Seals must be affixed and a Power of Attorney must be attached.

Agency \_\_\_\_\_  
REQ.P.O# \_\_\_\_\_

**BID BOND**

KNOW ALL MEN BY THESE PRESENTS, That we, the undersigned, \_\_\_\_\_  
of \_\_\_\_\_, \_\_\_\_\_, as Principal, and \_\_\_\_\_  
of \_\_\_\_\_, \_\_\_\_\_, a corporation organized and existing under the laws of the State of \_\_\_\_\_  
with its principal office in the City of \_\_\_\_\_, as Surety, are held and firmly bound unto the State  
of West Virginia, as Obligee, in the penal sum of \_\_\_\_\_ (\$ \_\_\_\_\_) for the payment of which,  
well and truly to be made, we jointly and severally bind ourselves, our heirs, administrators, executors, successors and assigns.

The Condition of the above obligation is such that whereas the Principal has submitted to the Purchasing Section of the  
Department of Administration a certain bid or proposal, attached hereto and made a part hereof, to enter into a contract in writing for  
\_\_\_\_\_  
\_\_\_\_\_  
\_\_\_\_\_

NOW THEREFORE,

- (a) If said bid shall be rejected, or
- (b) If said bid shall be accepted and the Principal shall enter into a contract in accordance with the bid or proposal attached hereto and shall furnish any other bonds and insurance required by the bid or proposal, and shall in all other respects perform the agreement created by the acceptance of said bid, then this obligation shall be null and void, otherwise this obligation shall remain in full force and effect. It is expressly understood and agreed that the liability of the Surety for any and all claims hereunder shall, in no event, exceed the penal amount of this obligation as herein stated.

The Surety, for the value received, hereby stipulates and agrees that the obligations of said Surety and its bond shall be in no way impaired or affected by any extension of the time within which the Obligee may accept such bid, and said Surety does hereby waive notice of any such extension.

IN WITNESS WHEREOF, Principal and Surety have hereunto set their hands and seals, and such of them as are corporations have caused their corporate seals to be affixed hereunto and these presents to be signed by their proper officers, this \_\_\_\_\_ day of \_\_\_\_\_, 20\_\_\_\_.

Principal Corporate Seal

\_\_\_\_\_  
(Name of Principal)

By \_\_\_\_\_

(Must be President or Vice President)

\_\_\_\_\_  
(Title)

Surety Corporate Seal

\_\_\_\_\_  
(Name of Surety)

\_\_\_\_\_  
Attorney-in-Fact

**IMPORTANT – Surety executing bonds must be licensed in West Virginia to transact surety insurance. Raised corporate seals must be affixed, a power of attorney must be attached.**