



State of West Virginia
 Department of Administration
 Purchasing Division
 2019 Washington Street East
 Post Office Box 50130
 Charleston, WV 25305-0130

Request for Quotation

RFQ NUMBER
COR61403

PAGE
1

ADDRESS CORRESPONDENCE TO ATTENTION OF
JOHN ABBOTT 304-558-2544

VENDOR

RFQ COPY
 TYPE NAME/ADDRESS HERE

SHIP TO

HUTTONSVILLE CORRECTIONAL
 CENTER
 ATTENTION: KEN HOLBROOK
 ROUTE 250 SOUTH
 HUTTONSVILLE, WV
 26273 335-2291

DATE PRINTED	TERMS OF SALE	SHIP VIA	F.O.B.	FREIGHT TERMS
04/06/2009				

BID OPENING DATE: 04/15/2009 BID OPENING TIME 01:30PM

LINE	QUANTITY	UOP	CAT. NO.	ITEM NUMBER	UNIT PRICE	AMOUNT
ADDENDUM #01						
THIS ADDENDUM IS ISSUED TO CLARIFY, MODIFY, AND ADD TO THE REQUIREMENTS OF THE ORIGINAL SPECIFICATIONS, PER THE ATTACHED DOCUMENTATION.						
0001	1	LS		968-20		
GUARD BUILDING AND TOWER						
***** THIS IS THE END OF RFQ COR61403 ***** TOTAL:						

SEE REVERSE SIDE FOR TERMS AND CONDITIONS			
SIGNATURE	TELEPHONE	DATE	
TITLE	FEIN	ADDRESS CHANGES TO BE NOTED ABOVE	

WHEN RESPONDING TO RFQ, INSERT NAME AND ADDRESS IN SPACE ABOVE LABELED 'VENDOR'

**GENERAL TERMS & CONDITIONS
REQUEST FOR QUOTATION (RFQ) AND REQUEST FOR PROPOSAL (RFP)**

1. Awards will be made in the best interest of the State of West Virginia.
2. The State may accept or reject in part, or in whole, any bid.
3. All quotations are governed by the *West Virginia Code* and the *Legislative Rules* of the Purchasing Division.
4. Prior to any award, the apparent successful vendor must be properly registered with the Purchasing Division and have paid the required \$125 fee.
5. All services performed or goods delivered under State Purchase Order/Contracts are to be continued for the term of the Purchase Order/Contracts, contingent upon funds being appropriated by the Legislature or otherwise being made available. In the event funds are not appropriated or otherwise available for these services or goods, this Purchase Order/Contract becomes void and of no effect after June 30.
6. Payment may only be made after the delivery and acceptance of goods or services.
7. Interest may be paid for late payment in accordance with the *West Virginia Code*.
8. Vendor preference will be granted upon written request in accordance with the *West Virginia Code*.
9. The State of West Virginia is exempt from federal and state taxes and will not pay or reimburse such taxes.
10. The Director of Purchasing may cancel any Purchase Order/Contract upon 30 days written notice to the seller.
11. The laws of the State of West Virginia and the *Legislative Rules* of the Purchasing Division shall govern all rights and duties under the Contract, including without limitation the validity of this Purchase Order/Contract.
12. Any reference to automatic renewal is hereby deleted. The Contract may be renewed only upon mutual written agreement of the parties.
13. **BANKRUPTCY:** In the event the vendor/contractor files for bankruptcy protection, this Contract may be deemed null and void, and terminated without further order.
14. **HIPAA BUSINESS ASSOCIATE ADDENDUM:** The West Virginia State Government HIPAA Business Associate Addendum (BAA), approved by the Attorney General, and available online at the Purchasing Division's web site (<http://www.state.wv.us/admin/purchase/vrc/hipaa.htm>) is hereby made part of the agreement. Provided that, the Agency meets the definition of a Cover Entity (45 CFR §160.103) and will be disclosing Protected Health Information (45 CFR §160.103) to the vendor.
15. **WEST VIRGINIA ALCOHOL & DRUG-FREE WORKPLACE ACT:** If this Contract constitutes a public improvement construction contract as set forth in Article 1D, Chapter 21 of the West Virginia Code ("The West Virginia Alcohol and Drug-Free Workplace Act"), then the following language shall hereby become part of this Contract: "The contractor and its subcontractors shall implement and maintain a written drug-free workplace policy in compliance with the West Virginia Alcohol and Drug-Free Workplace Act, as set forth in Article 1D, Chapter 21 of the West Virginia Code. The contractor and its subcontractors shall provide a sworn statement in writing, under the penalties of perjury, that they maintain a valid drug-free work place policy in compliance with the West Virginia and Drug-Free Workplace Act. It is understood and agreed that this Contract shall be cancelled by the awarding authority if the Contractor: 1) Fails to implement its drug-free workplace policy; 2) Fails to provide information regarding implementation of the contractor's drug-free workplace policy at the request of the public authority; or 3) Provides to the public authority false information regarding the contractor's drug-free workplace policy."

INSTRUCTIONS TO BIDDERS

1. Use the quotation forms provided by the Purchasing Division.
2. **SPECIFICATIONS:** Items offered must be in compliance with the specifications. Any deviation from the specifications must be clearly indicated by the bidder. Alternates offered by the bidder as **EQUAL** to the specifications must be clearly defined. A bidder offering an alternate should attach complete specifications and literature to the bid. The Purchasing Division may waive minor deviations to specifications.
3. Complete all sections of the quotation form.
4. Unit prices shall prevail in case of discrepancy.
5. All quotations are considered F.O.B. destination unless alternate shipping terms are clearly identified in the quotation.
6. **BID SUBMISSION:** All quotations must be delivered by the bidder to the office listed below prior to the date and time of the bid opening. Failure of the bidder to deliver the quotations on time will result in bid disqualifications: Department of Administration, Purchasing Division, 2019 Washington Street East, P.O. Box 50130, Charleston, WV 25305-0130

TO: John Abbott, Buyer
West Virginia Division of Purchasing

FROM: Bill Wimer, Construction Manager
West Virginia Division of Corrections

DATE: April 6, 2009

RE: COR61403 Addendum #1

The following information consists of Addendum#1 to the Huttonsville Correctional Center Guard Tower Project.

- Item #1 Contractor to cad weld ground cable to column.
- Item #2 Contractor to epoxy grout base plates.
- Item #3 Contractor may use owner's Porta-John.
- Item #4 Owner to supply electric to contractor.
- Item #5 Contractor to submit drawings with bid.
- Item #6 Contractor must comply with all security procedures.
- Item #7 Contractor to supply all additional concrete foundations required for the tower i.e. bottom of stairs and stair platform supports.
- Item #7 Foundation drawings attached.

DATE: 11/17

HUTTONSVILLE
GUARD TOWER FDN.

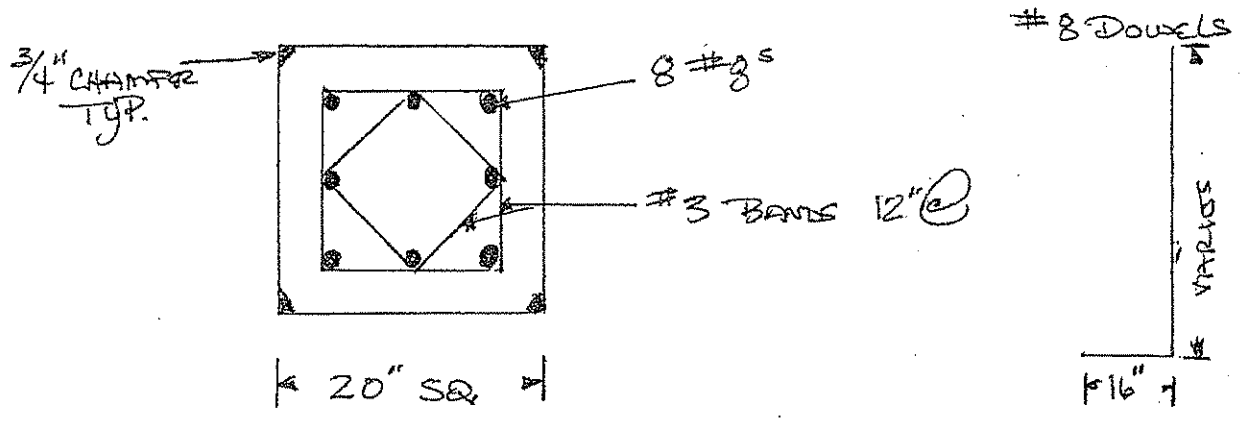
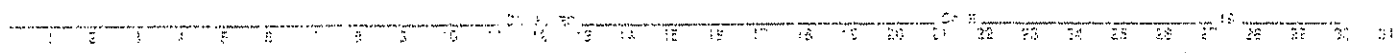

4500 PSI CONCRETE

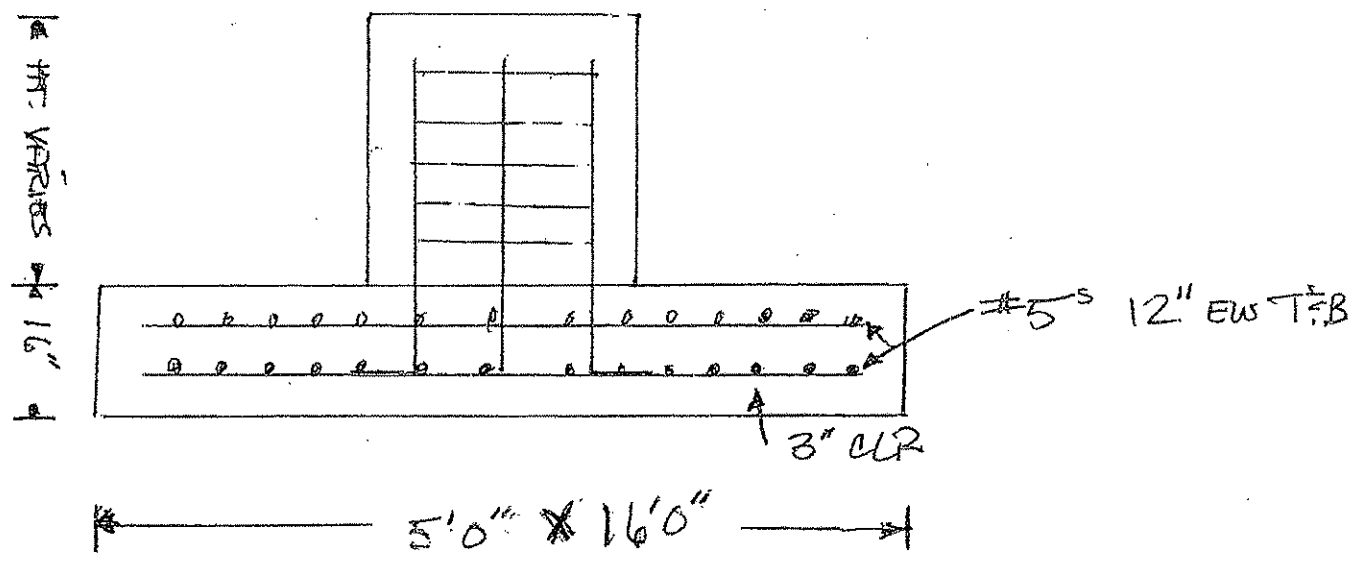

Grounding
N.T.S.

10 FT GROUND ROD IN BOTTOM OF FDN.
4rd COPPER GROUND CABLE TO EXTEND 2 FT ABOVE PIER



PROJECT: HUTTONSVILLE
GUARD TOWER FDN'S.

DATE: _____

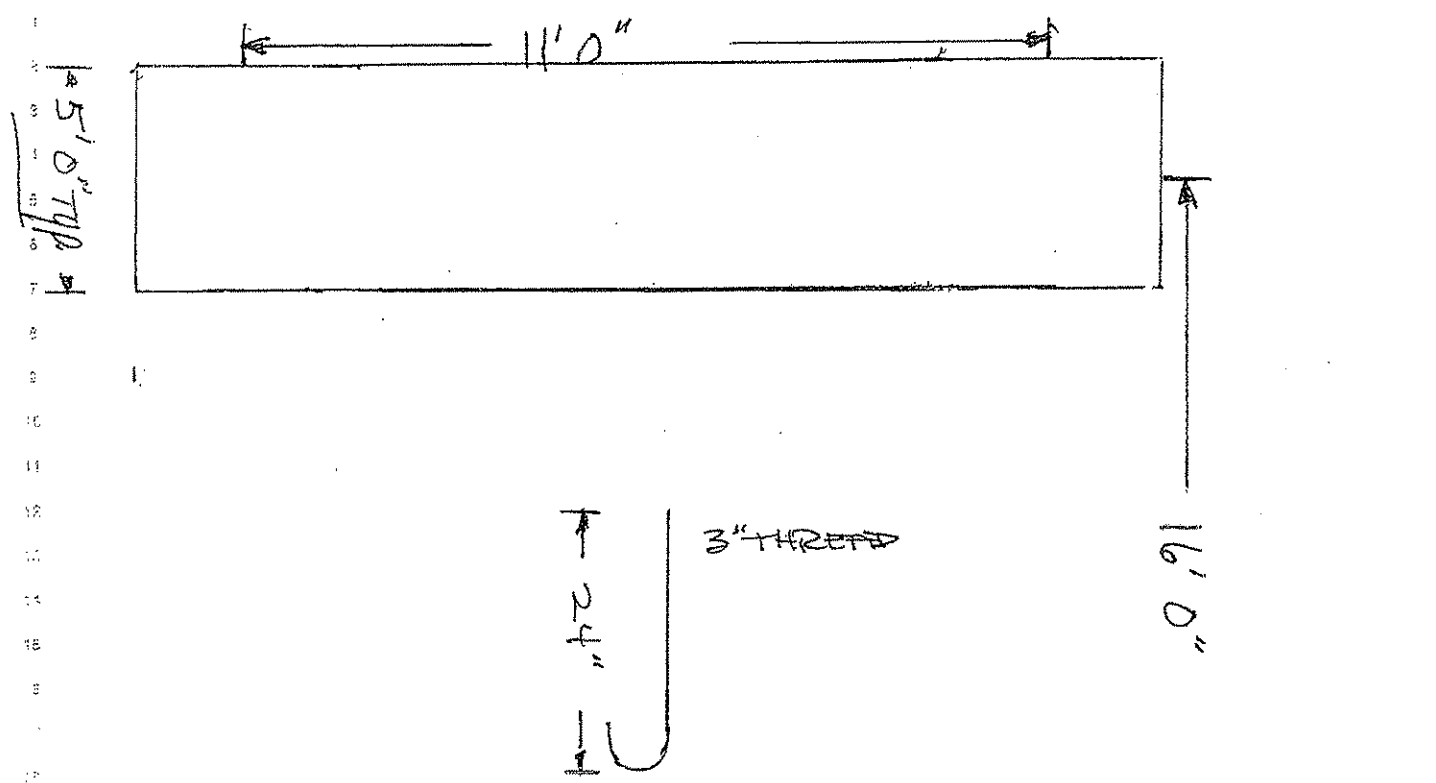

NOTE: $\frac{3}{4}$ " Φ ANCHOR BOLT - 4 PER PER GALVANIZED
 BOLT PATTERN AT LATER DATE

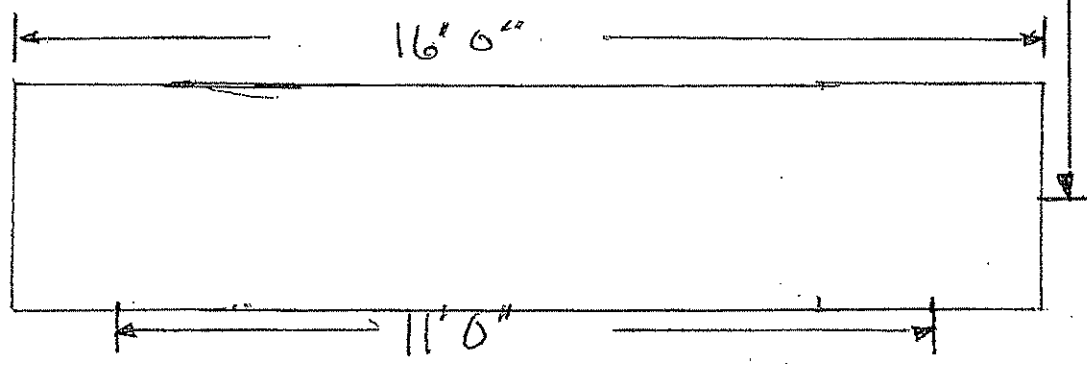

N.T.S.



Date: 4-1-2005

SIGN IN SHEET

Request for Proposal No. C0261403

PLEASE PRINT

* PLEASE BE SURE TO PRINT LEGIBLY - IF POSSIBLE, LEAVE A BUSINESS CARD

TELEPHONE & FAX NUMBERS

MAILING ADDRESS

FIRM & REPRESENTATIVE NAME

FIRM & REPRESENTATIVE NAME	MAILING ADDRESS	TELEPHONE & FAX NUMBERS
Company: PKBS	4133 Shoreline Drive	PHONE: 804-739-6023
Rep: BRIAN SANDUSKY	EARTH CITY, MO 63045	TOLL FREE: 800-456-5467 x804
Email Address: bsandusky@portaking.com		FAX: 314-291-2857
Company: Loading Dock Equipment	8505 Bell Creek Rd Suite A	PHONE: 804-730-0955
Rep: James Martin	Mcquensville VA 23116	TOLL FREE:
Email Address: James@LoadingDockEquip.com		FAX: 804-730-0956
Company: J.M. Stearts & Assoc.	206 Chase Dr	PHONE (304) 760-6020
Rep: Mike Stearts	Harmone WY 25526	TOLL FREE (304) 552-0658
Email Address: jstearts@steartshomes.com		FAX (304) 760-6019
Company: Shuck Construction Co.	1549 Tulip Lane	PHONE 304-366-9497
Rep: ROBERT L YANERO	Fairmont, WV 26554	TOLL FREE:
Email Address: rly@shuckconstwv.com		FAX 304-366-9407
Company: SCHNEIDER Const Co	P.O. Box 1685	PHONE 304-422-3579
Rep: PAUL C HOBLETZKE	Parkersburg, WV 26102	TOLL FREE:
Email Address: PAUL.SCHNEIDERCONST.COM		FAX: 422-3562

SIGN IN SHEET

Request for Proposal No. C07261403

PLEASE PRINT

* PLEASE BE SURE TO PRINT LEGIBLY - IF POSSIBLE, LEAVE A BUSINESS CARD

FIRM & REPRESENTATIVE NAME	MAILING ADDRESS	TELEPHONE & FAX NUMBERS
Company: <u>J. C. Bosley Const. Inc.</u>	<u>1 Bosley Ave</u>	PHONE <u>304-422-0025</u>
Rep: <u>Mark Husk</u>	<u>Parkrisburg WV 26101</u>	TOLL FREE
Email Address: <u>markh@jcbce.com</u>		FAX <u>304-422-0414</u>
Company: <u>Trij Le H Cont</u>	<u>Rt 1 Box 176</u>	PHONE <u>304-636-1194</u>
Rep: <u>Chuck Harper</u>	<u>Beverly W.Va</u>	TOLL FREE
Email Address: _____	<u>26253</u>	FAX <u>304-636-5680</u>
Company: <u>Danhill Const. Co</u>	<u>P.O. Box 685</u>	PHONE <u>304-632-1600</u>
Rep: <u>Dan Hill</u>	<u>Gaulley Bridge, W.Va</u>	TOLL FREE
Email Address: <u>rdanhill@hotmail.com</u>	<u>25085</u>	FAX <u>304-632-1501</u>
Company: _____	_____	PHONE _____
Rep: _____	_____	TOLL FREE _____
Email Address: _____	_____	FAX _____
Company: _____	_____	PHONE _____
Rep: _____	_____	TOLL FREE _____
Email Address: _____	_____	FAX _____

SIGN IN SHEET

Page 3 of 3

Date: 4-1-2009

Request for Proposal No. CR261403 PLEASE PRINT

* PLEASE BE SURE TO PRINT LEGIBLY - IF POSSIBLE, LEAVE A BUSINESS CARD

FIRM & REPRESENTATIVE NAME	MAILING ADDRESS	TELEPHONE & FAX NUMBERS
Company: G.A. Brown & Son, Inc.	215 Mill St	PHONE 304-363-4500
Rep: Warren Gregory	Fairmont, WV	TOLL FREE
Email Address: WGregory@GABrown.com	26554	FAX 304-366-9456
Company: City Window Construction	P.O. Box 23	PHONE 304-623-5178
Rep: Scott Waisemberger	Clarksburg, WV 26513	TOLL FREE
Email Address: Bewh@wbsl.net		FAX 304-623-5179
Company: Oval Construction	P.O. Box 401	PHONE 304-347-8820
Rep: Kent Williams	Charleston, WV 25322	TOLL FREE
Email Address: jcarney@ovalconstruction.com		FAX 304-347-8821
Company:		PHONE
Rep:		TOLL FREE
Email Address:		FAX
Company:		PHONE
Rep:		TOLL FREE
Email Address:		FAX