



State of West Virginia
 Department of Administration
 Purchasing Division
 2019 Washington Street East
 Post Office Box 50130
 Charleston, WV 25305-0130

Request for Quotation

RFQ NUMBER
859C2063

PAGE
1

ADDRESS CORRESPONDENCE TO ATTENTION OF
MICHAEL AUSTIN
304-558-2402

RFQ COPY
 TYPE NAME/ADDRESS HERE

V
E
N
D
O
R

S
H
I
P
T
O

DIVISION OF HIGHWAYS
 TRAFFIC ENG STORAGE FACILITY
 D-1, I-64 SECT 3 MAINT GARAGE
 US 119 NORTH OF CITY LIMITS
 CHARLESTON, WV
 25301 304-558-6266

DATE PRINTED	TERMS OF SALE	SHIP VIA	F.O.B.	FREIGHT TERMS
06/07/2009				

BID OPENING DATE: **06/24/2009** BID OPENING TIME **01:30PM**

LINE	QUANTITY	UOP	CAT NO.	ITEM NUMBER	UNIT PRICE	AMOUNT
0001				550-54		
<p>FURNISH BREAKAWAY SIGN SUPPORT, STUB POST</p> <p>OPEN END CONTRACT</p> <p>TO PROVIDE BREAKAWAY SIGN SUPPORTS, STUB POSTS, AND ASSOCIATED HARDWARE FOR THE WEST VIRGINIA DIVISION OF HIGHWAYS PER THE ATTACHED SPECIFICATIONS.</p> <p>PURCHASING CARD ACCEPTANCE: THE STATE OF WEST VIRGINIA CURRENTLY UTILIZES A VISA PURCHASING CARD PROGRAM WHICH IS ISSUED THROUGH A BANK. THE SUCCESSFUL VENDOR MUST ACCEPT THE STATE OF WEST VIRGINIA VISA PURCHASING CARD FOR PAYMENT OF ALL ORDERS PLACED BY ANY STATE AGENCY AS A CONDITION OF AWARD.</p> <p>EXHIBIT 3</p> <p>LIFE OF CONTRACT: THIS CONTRACT BECOMES EFFECTIVE ON AND EXTENDS FOR A PERIOD OF ONE (1) YEAR OR UNTIL SUCH "REASONABLE TIME" THEREAFTER AS IS NECESSARY TO OBTAIN A NEW CONTRACT OR RENEW THE ORIGINAL CONTRACT. THE "REASONABLE TIME" PERIOD SHALL NOT EXCEED TWELVE (12) MONTHS. DURING THIS "REASONABLE TIME" THE VENDOR MAY TERMINATE THIS CONTRACT FOR ANY REASON UPON GIVING THE DIRECTOR OF PURCHASING 30 DAYS WRITTEN NOTICE.</p> <p>UNLESS SPECIFIC PROVISIONS ARE STIPULATED ELSEWHERE</p>						

SEE REVERSE SIDE FOR TERMS AND CONDITIONS

SIGNATURE	TELEPHONE	DATE
TITLE	FEIN	ADDRESS CHANGES TO BE NOTED ABOVE

WHEN RESPONDING TO RFQ, INSERT NAME AND ADDRESS IN SPACE ABOVE LABELED 'VENDOR'

**GENERAL TERMS & CONDITIONS
REQUEST FOR QUOTATION (RFQ) AND REQUEST FOR PROPOSAL (RFP)**

1. Awards will be made in the best interest of the State of West Virginia.
2. The State may accept or reject in part, or in whole, any bid.
3. All quotations are governed by the *West Virginia Code* and the *Legislative Rules* of the Purchasing Division.
4. Prior to any award, the apparent successful vendor must be properly registered with the Purchasing Division and have paid the required \$125 fee.
5. All services performed or goods delivered under State Purchase Order/Contracts are to be continued for the term of the Purchase Order/Contracts, contingent upon funds being appropriated by the Legislature or otherwise being made available. In the event funds are not appropriated or otherwise available for these services or goods, this Purchase Order/Contract becomes void and of no effect after June 30.
6. Payment may only be made after the delivery and acceptance of goods or services.
7. Interest may be paid for late payment in accordance with the *West Virginia Code*.
8. Vendor preference will be granted upon written request in accordance with the *West Virginia Code*.
9. The State of West Virginia is exempt from federal and state taxes and will not pay or reimburse such taxes.
10. The Director of Purchasing may cancel any Purchase Order/Contract upon 30 days written notice to the seller.
11. The laws of the State of West Virginia and the *Legislative Rules* of the Purchasing Division shall govern all rights and duties under the Contract, including without limitation the validity of this Purchase Order/Contract.
12. Any reference to automatic renewal is hereby deleted. The Contract may be renewed only upon mutual written agreement of the parties.
13. **BANKRUPTCY:** In the event the vendor/contractor files for bankruptcy protection, the State may deem this contract null and void, and terminate such contract without further order.
14. **HIPAA BUSINESS ASSOCIATE ADDENDUM:** The West Virginia State Government HIPAA Business Associate Addendum (BAA), approved by the Attorney General, and available online at the Purchasing Division's web site (<http://www.state.wv.us/admin/purchase/vrc/hipaa.htm>) is hereby made part of the agreement. Provided that, the Agency meets the definition of a Cover Entity (45 CFR §160.103) and will be disclosing Protected Health Information (45 CFR §160.103) to the vendor.
15. **WEST VIRGINIA ALCOHOL & DRUG-FREE WORKPLACE ACT:** If this Contract constitutes a public improvement construction contract as set forth in Article 1D, Chapter 21 of the West Virginia Code ("The West Virginia Alcohol and Drug-Free Workplace Act"), then the following language shall hereby become part of this Contract: "The contractor and its subcontractors shall implement and maintain a written drug-free workplace policy in compliance with the West Virginia Alcohol and Drug-Free Workplace Act, as set forth in Article 1D, Chapter 21 of the West Virginia Code. The contractor and its subcontractors shall provide a sworn statement in writing, under the penalties of perjury, that they maintain a valid drug-free work place policy in compliance with the West Virginia and Drug-Free Workplace Act. It is understood and agreed that this Contract shall be cancelled by the awarding authority if the Contractor: 1) Fails to implement its drug-free workplace policy; 2) Fails to provide information regarding implementation of the contractor's drug-free workplace policy at the request of the public authority; or 3) Provides to the public authority false information regarding the contractor's drug-free workplace policy."

INSTRUCTIONS TO BIDDERS

1. Use the quotation forms provided by the Purchasing Division.
2. **SPECIFICATIONS:** Items offered must be in compliance with the specifications. Any deviation from the specifications must be clearly indicated by the bidder. Alternates offered by the bidder as **EQUAL** to the specifications must be clearly defined. A bidder offering an alternate should attach complete specifications and literature to the bid. The Purchasing Division may waive minor deviations to specifications.
3. Complete all sections of the quotation form.
4. Unit prices shall prevail in case of discrepancy.
5. All quotations are considered F.O.B. destination unless alternate shipping terms are clearly identified in the quotation.
6. **BID SUBMISSION:** All quotations must be delivered by the bidder to the office listed below prior to the date and time of the bid opening. Failure of the bidder to deliver the quotations on time will result in bid disqualifications: Department of Administration, Purchasing Division, 2019 Washington Street East, P.O. Box 50130, Charleston, WV 25305-0130



State of West Virginia
 Department of Administration
 Purchasing Division
 2019 Washington Street East
 Post Office Box 50130
 Charleston, WV 25305-0130

Request for Quotation

RFQ NUMBER
859C2063

PAGE
2

ADDRESS CORRESPONDENCE TO ATTENTION OF:
MICHAEL AUSTIN
304-558-2402

RFQ COPY
 TYPE NAME/ADDRESS HERE

VENDOR

SHIP TO

DIVISION OF HIGHWAYS
 TRAFFIC ENG STORAGE FACILITY
 D-1, I-64 SECT 3 MAINT GARAGE
 US 119 NORTH OF CITY LIMITS
 CHARLESTON, WV
 25301 304-558-6266

DATE PRINTED 06/07/2009	TERMS OF SALE	SHIP VIA	F.O.B.	FREIGHT TERMS
-----------------------------------	---------------	----------	--------	---------------

BID OPENING DATE: **06/24/2009** BID OPENING TIME **01:30PM**

LINE	QUANTITY	UOP	CAT. NO.	ITEM NUMBER	UNIT PRICE	AMOUNT
<p>IN THIS CONTRACT DOCUMENT, THE TERMS, CONDITIONS AND PRICING SET HEREIN ARE FIRM FOR THE LIFE OF THE CONTRACT.</p> <p>RENEWAL: THIS CONTRACT MAY BE RENEWED UPON THE MUTUAL WRITTEN CONSENT OF THE SPENDING UNIT AND VENDOR, SUBMITTED TO THE DIRECTOR OF PURCHASING THIRTY (30) DAYS PRIOR TO THE EXPIRATION DATE. SUCH RENEWAL SHALL BE IN ACCORDANCE WITH THE TERMS AND CONDITIONS OF THE ORIGINAL CONTRACT AND SHALL BE LIMITED TO TWO (2) ONE (1) YEAR PERIODS.</p> <p>CANCELLATION: THE DIRECTOR OF PURCHASING RESERVES THE RIGHT TO CANCEL THIS CONTRACT IMMEDIATELY UPON WRITTEN NOTICE TO THE VENDOR IF THE COMMODITIES AND/OR SERVICES SUPPLIED ARE OF AN INFERIOR QUALITY OR DO NOT CONFORM TO THE SPECIFICATIONS OF THE BID AND CONTRACT HEREIN.</p> <p>OPEN MARKET CLAUSE: THE DIRECTOR OF PURCHASING MAY AUTHORIZE A SPENDING UNIT TO PURCHASE ON THE OPEN MARKET, WITHOUT THE FILING OF A REQUISITION OR COST ESTIMATE, ITEMS SPECIFIED ON THIS CONTRACT FOR IMMEDIATE DELIVERY IN EMERGENCIES DUE TO UNFORESEEN CAUSES (INCLUDING BUT NOT LIMITED TO DELAYS IN TRANSPORTATION OR AN UNANTICIPATED INCREASE IN THE VOLUME OF WORK.)</p> <p>QUANTITIES: QUANTITIES LISTED IN THE REQUISITION ARE APPROXIMATIONS ONLY, BASED ON ESTIMATES SUPPLIED BY THE STATE SPENDING UNIT. IT IS UNDERSTOOD AND AGREED THAT THE CONTRACT SHALL COVER THE QUANTITIES ACTUALLY ORDERED FOR DELIVERY DURING THE TERM OF THE CONTRACT, WHETHER MORE OR LESS THAN THE QUANTITIES SHOWN.</p> <p>ORDERING PROCEDURE: SPENDING UNIT(S) SHALL ISSUE A WRITTEN STATE CONTRACT ORDER (FORM NUMBER WV-39) TO</p>						

SEE REVERSE SIDE FOR TERMS AND CONDITIONS

SIGNATURE	TELEPHONE	DATE
TITLE	FEIN	ADDRESS CHANGES TO BE NOTED ABOVE

WHEN RESPONDING TO RFQ, INSERT NAME AND ADDRESS IN SPACE ABOVE LABELED 'VENDOR'



State of West Virginia
 Department of Administration
 Purchasing Division
 2019 Washington Street East
 Post Office Box 50130
 Charleston, WV 25305-0130

Request for Quotation

RFQ NUMBER
859C2063

PAGE
3

ADDRESS CORRESPONDENCE TO ATTENTION OF
MICHAEL AUSTIN
304-558-2402

RFQ COPY
 TYPE NAME/ADDRESS HERE

VENDOR

SHIP TO

DIVISION OF HIGHWAYS
 TRAFFIC ENG STORAGE FACILITY
 D-1, I-64 SECT 3 MAINT GARAGE
 US 119 NORTH OF CITY LIMITS
 CHARLESTON, WV
 25301 304-558-6266

DATE PRINTED 06/07/2009	TERMS OF SALE	SHIP VIA	FOB	FREIGHT TERMS
BID OPENING DATE: 06/24/2009		BID OPENING TIME 01:30PM		

LINE	QUANTITY	UOP	CAT NO	ITEM NUMBER	UNIT PRICE	AMOUNT
<p>THE VENDOR FOR COMMODITIES COVERED BY THIS CONTRACT. THE ORIGINAL COPY OF THE WV-39 SHALL BE MAILED TO THE VENDOR AS AUTHORIZATION FOR SHIPMENT, A SECOND COPY MAILED TO THE PURCHASING DIVISION, AND A THIRD COPY RETAINED BY THE SPENDING UNIT.</p> <p>BANKRUPTCY: IN THE EVENT THE VENDOR/CONTRACTOR FILES FOR BANKRUPTCY PROTECTION, THE STATE MAY DEEM THE CONTRACT NULL AND VOID, AND TERMINATE SUCH CONTRACT WITHOUT FURTHER ORDER.</p> <p>THE TERMS AND CONDITIONS CONTAINED IN THIS CONTRACT SHALL SUPERSEDE ANY AND ALL SUBSEQUENT TERMS AND CONDITIONS WHICH MAY APPEAR ON ANY ATTACHED PRINTED DOCUMENTS SUCH AS PRICE LISTS, ORDER FORMS, SALES AGREEMENTS OR MAINTENANCE AGREEMENTS, INCLUDING ANY ELECTRONIC MEDIUM SUCH AS CD-ROM.</p> <p>REV. 05/26/2009</p> <p>EXHIBIT 10</p> <p style="text-align: center;">REQUISITION NO.:</p> <p>ADDENDUM ACKNOWLEDGEMENT</p> <p>I HEREBY ACKNOWLEDGE RECEIPT OF THE FOLLOWING CHECKED ADDENDUM(S) AND HAVE MADE THE NECESSARY REVISIONS TO MY PROPOSAL, PLANS AND/OR SPECIFICATION, ETC.</p> <p>ADDENDUM NO.'S:</p> <p>NO. 1</p> <p>NO. 2</p>						

SEE REVERSE SIDE FOR TERMS AND CONDITIONS

SIGNATURE	TELEPHONE	DATE
TITLE	FEIN	ADDRESS CHANGES TO BE NOTED ABOVE

WHEN RESPONDING TO RFQ, INSERT NAME AND ADDRESS IN SPACE ABOVE LABELED 'VENDOR'



State of West Virginia
 Department of Administration
 Purchasing Division
 2019 Washington Street East
 Post Office Box 50130
 Charleston, WV 25305-0130

Request for Quotation

RFQ NUMBER
859C2063

PAGE
4

ADDRESS CORRESPONDENCE TO ATTENTION OF:
MICHAEL AUSTIN
304-558-2402

RFQ COPY
 TYPE NAME/ADDRESS HERE

VENDOR

SHIP TO

DIVISION OF HIGHWAYS
 TRAFFIC ENG STORAGE FACILITY
 D-1, I-64 SECT 3 MAINT GARAGE
 US 119 NORTH OF CITY LIMITS
 CHARLESTON; WV
 25301 304-558-6266

DATE PRINTED	TERMS OF SALE	SHIP VIA	F.O.B.	FREIGHT TERMS
06/07/2009				

BID OPENING DATE: **06/24/2009** BID OPENING TIME **01:30PM**

LINE	QUANTITY	UOP	CAT. NO.	ITEM NUMBER	UNIT PRICE	AMOUNT
	NO. 3					
	NO. 4					
	NO. 5					
<p>I UNDERSTAND THAT FAILURE TO CONFIRM THE RECEIPT OF THE ADDENDUM(S) MAY BE CAUSE FOR REJECTION OF BIDS.</p> <p>VENDOR MUST CLEARLY UNDERSTAND THAT ANY VERBAL REPRESENTATION MADE OR ASSUMED TO BE MADE DURING ANY ORAL DISCUSSION HELD BETWEEN VENDOR'S REPRESENTATIVES AND ANY STATE PERSONNEL IS NOT BINDING. ONLY THE INFORMATION ISSUED IN WRITING AND ADDED TO THE SPECIFICATIONS BY AN OFFICIAL ADDENDUM IS BINDING.</p> <p>..... SIGNATURE</p> <p>..... COMPANY</p> <p>..... DATE</p> <p>REV. 11/96</p> <p>NOTICE</p> <p>A SIGNED BID MUST BE SUBMITTED TO: DEPARTMENT OF ADMINISTRATION</p>						

SEE REVERSE SIDE FOR TERMS AND CONDITIONS

SIGNATURE	TELEPHONE	DATE
TITLE	FEIN	ADDRESS CHANGES TO BE NOTED ABOVE

WHEN RESPONDING TO RFQ, INSERT NAME AND ADDRESS IN SPACE ABOVE LABELED 'VENDOR'



State of West Virginia
 Department of Administration
 Purchasing Division
 2019 Washington Street East
 Post Office Box 50130
 Charleston, WV 25305-0130

Request for Quotation

RFQ NUMBER
859C2063

PAGE
5

ADDRESS CORRESPONDENCE TO ATTENTION OF:
MICHAEL AUSTIN
304-558-2402

RFQ COPY
TYPE NAME/ADDRESS HERE

VENDOR

SHIP TO

DIVISION OF HIGHWAYS
TRAFFIC ENG STORAGE FACILITY
D-1, I-64 SECT 3 MAINT GARAGE
US 119 NORTH OF CITY LIMITS
CHARLESTON, WV
25301 **304-558-6266**

DATE PRINTED	TERMS OF SALE	SHIP VIA	F.O.B.	FREIGHT TERMS
06/07/2009				

BID OPENING DATE: **06/24/2009** BID OPENING TIME **01:30PM**

LINE	QUANTITY	UOP	CAT. NO.	ITEM NUMBER	UNIT PRICE	AMOUNT
	PURCHASING DIVISION BUILDING 15 2019 WASHINGTON STREET, EAST CHARLESTON, WV 25305-0130					
	THE BID SHOULD CONTAIN THIS INFORMATION ON THE FACE OF THE ENVELOPE OR THE BID MAY NOT BE CONSIDERED: SEALED BID BUYER:----- RFQ. NO.:----- BID OPENING DATE:----- BID OPENING TIME:-----					
	PLEASE PROVIDE A FAX NUMBER IN CASE IT IS NECESSARY TO CONTACT YOU REGARDING YOUR BID: ----- CONTACT PERSON (PLEASE PRINT CLEARLY): -----					

SEE REVERSE SIDE FOR TERMS AND CONDITIONS

SIGNATURE	TELEPHONE	DATE
TITLE	FEIN	ADDRESS CHANGES TO BE NOTED ABOVE

WHEN RESPONDING TO RFQ, INSERT NAME AND ADDRESS IN SPACE ABOVE LABELED 'VENDOR'



State of West Virginia
 Department of Administration
 Purchasing Division
 2019 Washington Street East
 Post Office Box 50130
 Charleston, WV 25305-0130

Request for Quotation

RFQ NUMBER
859C2063

PAGE
6

ADDRESS CORRESPONDENCE TO ATTENTION OF
**MICHAEL AUSTIN
 304-558-2402**

RFQ COPY
 TYPE NAME/ADDRESS HERE

V
E
N
D
O
R

S
H
I
P
T
O

DIVISION OF HIGHWAYS
 TRAFFIC ENG STORAGE FACILITY
 D-1, I-64 SECT 3 MAINT GARAGE
 US 119 NORTH OF CITY LIMITS
 CHARLESTON, WV
 25301 304-558-6266

DATE PRINTED	TERMS OF SALE	SHIP VIA	F.O.B.	FREIGHT TERMS
06/07/2009				

BID OPENING DATE: **06/24/2009** BID OPENING TIME **01:30PM**

LINE	QUANTITY	UOP	CAT. NO.	ITEM NUMBER	UNIT PRICE	AMOUNT
***** THIS IS THE END OF RFQ 859C2063 ***** TOTAL:						_____

SEE REVERSE SIDE FOR TERMS AND CONDITIONS

SIGNATURE		TELEPHONE	DATE
TITLE	FEIN	ADDRESS CHANGES TO BE NOTED ABOVE	

WHEN RESPONDING TO RFQ, INSERT NAME AND ADDRESS IN SPACE ABOVE LABELED 'VENDOR'

SCOPE OF CONTRACT

The purpose of this Contract shall be to furnish breakaway sign supports, stub posts, and associated hardware, as required, to the West Virginia Division of Highways.

SPECIFICATIONS

Materials and fabrication shall conform to the West Virginia Division of Highways' Standard Specifications Roads and Bridges, adopted 2000 and latest published addendum to the 2000 Specifications. All structural steel shall conform to ASTM A-572, Grade 50. All galvanizing shall conform to ASTM A-123. Stubs and supports shall be manufactured in compliance with the West Virginia Division of Highways' Standard Sheets TE 1-3A and TE 1-3B.

All complete sign supports shall be furnished with hinge plates, base plate, saw cut, properly drilled holes, keeper plate, shims, and all associated hardware required for assembly at saw cut and at base. Unless otherwise noted on order, complete posts shall be delivered pre-assembled at saw cut.

All bottom only sign support orders, which are ordered from the saw cut down only, shall be furnished with hinge plates, base plate, properly drilled holes, keeper plate, shims, and all associated hardware required for assembly at base. Saw cut hardware will not be required.

All top only sign support orders, which are ordered from the saw cut up only, shall be furnished with properly drilled holes.

All stub posts shall be furnished with a base plate.

Shop drawings shall be submitted as normally required by the Division's specifications.

Shop drawings shall be submitted by email if possible to Danny Young at the following E-mail address: danny.g.young@wv.gov

Shop drawing submittal by regular mail will be accepted if the Vendor chooses to submit shop drawings in this manner. Two (2) copies shall be submitted to the following address:

WVDOH-Traffic Engineering Division
Bldg. 5 – Room A550
1900 Kanawha Blvd. E.
Charleston, WV 25305
ATTN: Danny Young

EXCEPTIONS TO STANDARD DETAILS

Base plates for all W-shaped stub post and sign support bottoms shall be fabricated according to attached detail for base plate.

Keeper plate hole diameter shall equal bolt diameter plus 1/8".

ASSEMBLY NUMBER MARKINGS

All complete sign supports shall have the "ASSEMBLY NUMBER" shown on the included individual post listing written in permanent black marker on both flanges of each support. The assembly number shall be written in approximately 2" tall letters approximately 12" above the base plate.

ASSOCIATED HARDWARE

In addition to purchasing sign supports with hardware included, the Department shall have the ability to purchase additional hardware for repair purposes.

PACKAGE QUANTITY

The following items shall be ordered in quantities of one (1) each per unit:

- Keeper plates – Shall be ordered such that plates may be shipped in packages of 10. That is, the number of units of plates ordered shall be in multiples of 10.
- Brass Shims – Shall be ordered such that shims may be shipped in packages of 10 each 0.012 shims and 10 each 0.032 shims. That is, the number of units of 0.012 shims ordered shall be in multiples of 10. For every 10 units of 0.012 shims ordered, 10 units of 0.032 shims shall be ordered.
- Nuts, Bolts, Washers – Shall be ordered such that nuts, bolts, or washers may be shipped in packages of 25 each nuts, bolts, or washers per package. That is, the number of units of nuts, bolts, or washers ordered shall be in multiples of 25.
- Hinge Plates.
- S4X7.7 stub post, S4x7.7 stub post w/ flat connection and left-hand slot plate bevel, W6x12 stub post, W8x18 stub post and W10x22 stub post.

The following items shall be ordered in quantities of one (1) foot per unit:

- S4x7.7 sign support, S4x7.7 sign support w/ flat connection and left-hand slot plate bevel, W6x12 sign support, W8x18 sign support and W10x22 sign support.

DELIVERY

The minimum order size for Releases off of this Contract shall be based on weight. The weight of orders, for this purpose, shall be based on the weight of all stubs and sign supports on the order. This shall include saw cut connection plates (hinge plates). The weight of assembly hardware shall be considered nominal for this purpose, and shall not be included in the weight calculations. The unit weight of components used in calculations shall be as follows:

S4 x 7.7 Stub Posts	16.55 #
W6 x 12 Stub Posts	37.35 #
W8 x 18 Stub Posts	71.39 #
W10 x 22 Stub Posts	100.06 #
S4 x 7.7 Support (excluding base plate and stiffeners)	8.20 #
W6 x 12 Support (excluding base plate and stiffeners)	12.78 #
W8 x 18 Support (excluding base plate and stiffeners)	19.17 #
W10 x 22 Support (excluding base plate and stiffeners)	23.43 #
S4 x 7.7 Support base plate and stiffeners	4.25 #
W6 x 12 Support base plate and stiffeners	12.52 #
W8 x 18 Support base plate and stiffeners	24.42 #
W10 x 22 Support base plate and stiffeners	28.04 #
S4 x 7.7 Hinge Plate	0.69 #
W6 x12 Hinge Plate	1.22 #
W8 x 18 Hinge Plate	2.84 #
W10 x 22 Hinge Plate	3.18 #

The above values include a 6.5% addition to the weight for galvanizing.

The minimum State Contract Order (SCO) shall be 35,000 lbs. The Vendor shall be allowed sixty (60) calendar days A.R.O. for delivery. Late delivery charges against the vendor may be assessed at a rate of \$120.00 per calendar day after sixty (60) days ARO. With respect to periodic delays and disruptions to stock beam supplies, the Division may give consideration to waiving the specified late delivery charges and extending the delivery deadline on particular orders, providing that the Vendor can supply sufficient documentation explaining that the Vendor's inability to furnish the ordered material in the specified time frame is beyond the reasonable control of the Vendor. In these cases, after providing notification to either Ted Whitmore or Danny Young at 304-558-3063, the vendor may be required to mail the above mentioned documentation to the WVDOH at the following address:

WVDOH-Traffic Engineering Division
Bldg 5 – Room A550
1900 Kanawha Blvd. East
Charleston, WV 25305
ATTN: Danny Young

In addition, the vendor must also be willing to proceed with the shipment of those items listed on the order within the specified sixty (60) day time frame that are unaffected by the vendor's stock material supply delays or disruptions, with no additional costs to the Division.

The Division will make every effort to place orders ranging in total weight between 35,000 and 40,000 lbs. The Vendor shall, however, be obligated to honor orders exceeding 40,000 lbs. as described herein with no additional delays or expense to the Division.

Notification of shipment from vendor shall be received a minimum of 48 hours before delivery of material. Vendor shall contact either Chuck Swigger or Ray Higginbotham at 304-558-6356 or Ted Whitmore or Danny Young at 304-558-3063.

PRICE ADJUSTMENT CLAUSE

The State of West Virginia will consider bids that contain provisions for price adjustments prior to the original expiration date of the Contract, provided that such price adjustment covers both upward and downward movement of the commodity price, and that adjustment is based on the "pass through" increase or decrease of raw materials and/or labor, which make up all or a substantial part of a product. Adjustments are to be based upon an actual dollar figure, not a percentage. All price adjustment requests must be substantiated in a manner acceptable to the Director of the WV Purchasing Division (e.g. governmental bench marks, general market increases, and published price lists). All documentation of price increases incurred by the vendor shall be based on governmental bench marks, general market increases, published price lists, etc. in effect on the original effective date of the Contract, or the effective date of the currently approved price increase in effect, as applicable. Such requests for price increases shall be received in writing by the Director of the Traffic Engineering Division at least 30-days in advance of the proposed effective date of the increase. The price increase request will be evaluated by the Traffic Engineering Division and will be forwarded to the Purchasing Division for concurrence. The vendor may not submit a request for a price increase with a proposed effective date less than 90-days from the original effective date of the Contract. Subsequent requests for price increases may not have a proposed effective date less than 90-days from the effective date of the currently approved price increase in effect. Any time the vendor requests a

price adjustment; the Purchasing Division may either accept the price adjustment and amend the Contract accordingly or reject the adjustment in its entirety and cancel the Contract.

AVAILABILITY OF STANDARD DETAILS AND SPECIFICATIONS

The Standard Specifications and Standard Details referenced in this contract may be obtained by contacting the West Virginia Division of Highways Engineering Division at 304-558-2830, or may be viewed online at the following web address:

www.wvdot.com/engineering/TOC_engineering.htm

W6 x 12 = 10" - *

W8 x 18 = 12½" - *

W10 x 22 = 14½" - *

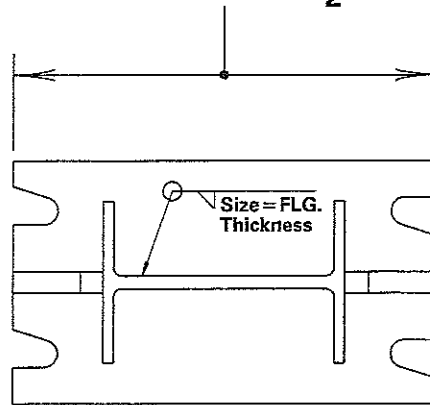

**SECTION A-A PER STANDARD DETAIL
TE1-3A-REVISED (SECTION B-B SIMILAR)**

* - IF NECESSARY, THESE DIMENSIONS SHALL BE ADJUSTED SLIGHTLY IN ORDER TO MAINTAIN DIMENSIONS B and C AS SHOWN ON STANDARD DETAIL TE1-3A.

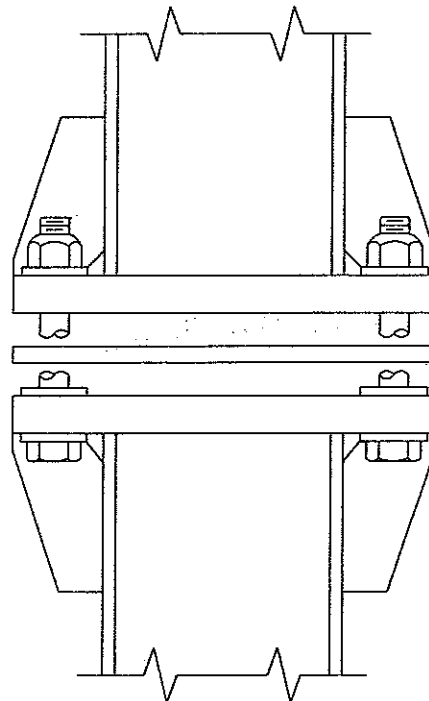

**SIGN POST AND STUB POST ELEVATION
(FOR W-SHAPES) PER STANDARD DETAIL TE1-3A**

**ALL DIMENSIONS AND DETAILS NOT
SHOWN SHALL BE PER STANDARD TE1-3A.**

BID SCHEDULE

The following estimated quantities are for bid purposes only. Actual quantities will be determined by needs of the West Virginia Division of Highways and may be increased or decreased.

ITEM NO.	ESTIMATED QUANTITY	DESCRIPTION	UNIT PRICE	AMOUNT
1	150	PER EACH, S4X7.7 STUB POST		
2	25	PER EACH, S4X7.7 STUB POST W/ FLAT CONNECTION AND LEFT HAND SLOT PLATE BEVEL		
3	100	PER EACH, W6X12 STUB POST		
4	50	PER EACH, W8X18 STUB POST		
5	25	PER EACH, W10X22 STUB POST		
6	1000	PER L.F. S4X7.7 SIGN SUPPORT (TOPS ONLY)		
7	1500 *	PER L.F. S4X7.7 SIGN SUPPORT (BOTTOMS ONLY)		
8	14 **	PER L.F. S4X7.7 SIGN SUPPORT (COMPLETE POST)		
9	250 *	PER L.F. S4X7.7 SIGN SUPPORT W/ FLAT CONNECTION AND LEFT HAND SLOT PLATE BEVEL (BOTTOMS ONLY)		
10	15 **	PER L.F. S4X7.7 SIGN SUPPORT W/ FLAT CONNECTION AND LEFT HAND SLOT PLATE BEVEL (COMPLETE POST)		
11	1000	PER L.F. W6X12 SIGN SUPPORT (TOPS ONLY)		
12	1000 *	PER L.F. W6X12 SIGN SUPPORT (BOTTOMS ONLY)		
13	19 **	PER L.F. W6X12 SIGN SUPPORT (COMPLETE POST)		
14	500	PER L.F. W8X18 SIGN SUPPORT (TOPS ONLY)		
15	1000 *	PER L.F. W8X18 SIGN SUPPORT (BOTTOMS ONLY)		
16	22 **	PER L.F. W8X18 SIGN SUPPORT (COMPLETE POST)		
17	500	PER L.F. W10X22 SIGN SUPPORT (TOPS ONLY)		
18	500 *	PER L.F. W10X22 SIGN SUPPORT (BOTTOMS ONLY)		
19	25 **	PER L.F. W10X22 SIGN SUPPORT (COMPLETE POST)		
20	10	PER EA., KEEPER PLATE S4X7.7		
21	10	PER EA., KEEPER PLATE W6X12		
22	10	PER EA., KEEPER PLATE W8X18		
23	10	PER EA., KEEPER PLATE W10X22		
24	1	PER EACH, HINGE PLATE S4X7.7		
25	1	PER EACH, HINGE PLATE W6X12		
26	1	PER EACH, HINGE PLATE W8X18		
27	1	PER EACH, HINGE PLATE W10X22		
28	10	PER EA., BRASS SHIMS 0.012		
29	10	PER EA., BRASS SHIMS 0.032		
30	25	PER EA., 1/2" X 1 3/4" HEAVY HEX BOLT		
31	25	PER EA., 1/2" X 2 1/2" HEAVY HEX BOLT		
32	25	PER EA., 1/2" BEVEL WASHER		

ITEM NO.	ESTIMATED QUANTITY	DESCRIPTION	UNIT PRICE	AMOUNT
33	25	PER EA., 1/2" HEAVY HEX NUT		
34	25	PER EA., 1/2" STRUCTURAL FLAT WASHER		
35	25	PER EA., 5/8" X 2 3/4" HEAVY HEX BOLT		
36	25	PER EA., 5/8" HEAVY HEX NUT		
37	25	PER EA., 5/8" STRUCTURAL FLAT WASHER		
38	25	PER EA., 3/4" X 3 1/2" HEAVY HEX BOLTS		
39	25	PER EA., 3/4" X 2 1/4" HEAVY HEX BOLTS		
40	25	PER EA., 3/4" HEAVY HEX NUTS		
41	25	PER EA., 3/4" STRUCTURAL FLAT WASHER		
42	25	PER EA., 7/8" X 2 1/4" HEAVY HEX BOLTS		
43	25	PER EA., 7/8" HEAVY HEX NUTS		
44	25	PER EA., 7/8" STRUCTURAL FLAT WASHER		
TOTAL				

* - FOR ADDITIONAL INFORMATION FOR BID PURPOSES, IT IS ESTIMATED THAT THE TOTAL NUMBER OF INDIVIDUAL POSTS TO BE ORDERED UNDER ITEM NUMBERS 7, 9, 12, 15 AND 18 IS 195, 30, 120, 110, AND 50, RESPECTIVELY. THIS IS BASED ON THE ESTIMATED FOOTAGE SHOWN AND THE CALCULATED AVERAGE LENGTH OF EACH INDIVIDUAL TYPE POST ORDERED OVER A TWO YEAR PERIOD.

** - FOR ADDITIONAL INFORMATION FOR BID PURPOSES, IT IS ESTIMATED THAT THE FOOTAGE SHOWN FOR ITEM NUMBERS 8, 10, 13, 16, AND 19 IS REPRESENTATIVE OF ONE COMPLETE POST OF THE TYPE SPECIFIED. THIS IS BASED ON CALCULATED AVERAGE POST LENGTHS ORDERED OVER A TWO YEAR PERIOD. THESE ITEM NUMBERS ARE TYPICALLY NOT UTILIZED.

VENDOR PREFERENCE CERTIFICATE

Certification and application* is hereby made for Preference in accordance with West Virginia Code, §5A-3-37. (Does not apply to construction contracts). West Virginia Code, §5A-3-37, provides an opportunity for qualifying vendors to request (at the time of bid) preference for their residency status. Such preference is an evaluation method only and will be applied only to the cost bid in accordance with the West Virginia Code. This certificate for application is to be used to request such preference. The Purchasing Division will make the determination of the Resident Vendor Preference, if applicable.

- 1. Application is made for 2.5% resident vendor preference for the reason checked: Bidder is an individual resident vendor and has resided continuously in West Virginia for four (4) years immediately preceding the date of this certification; or, Bidder is a partnership, association or corporation resident vendor and has maintained its headquarters or principal place of business continuously in West Virginia for four (4) years immediately preceding the date of this certification; or 80% of the ownership interest of Bidder is held by another individual, partnership, association or corporation resident vendor who has maintained its headquarters or principal place of business continuously in West Virginia for four (4) years immediately preceding the date of this certification; or, Bidder is a nonresident vendor which has an affiliate or subsidiary which employs a minimum of one hundred state residents and which has maintained its headquarters or principal place of business within West Virginia continuously for the four (4) years immediately preceding the date of this certification; or,
2. Application is made for 2.5% resident vendor preference for the reason checked: Bidder is a resident vendor who certifies that, during the life of the contract, on average at least 75% of the employees working on the project being bid are residents of West Virginia who have resided in the state continuously for the two years immediately preceding submission of this bid; or,
3. Application is made for 2.5% resident vendor preference for the reason checked: Bidder is a nonresident vendor employing a minimum of one hundred state residents or is a nonresident vendor with an affiliate or subsidiary which maintains its headquarters or principal place of business within West Virginia employing a minimum of one hundred state residents who certifies that, during the life of the contract, on average at least 75% of the employees or Bidder's affiliate's or subsidiary's employees are residents of West Virginia who have resided in the state continuously for the two years immediately preceding submission of this bid; or,
4. Application is made for 5% resident vendor preference for the reason checked: Bidder meets either the requirement of both subdivisions (1) and (2) or subdivision (1) and (3) as stated above; or,
5. Application is made for 3.5% resident vendor preference who is a veteran for the reason checked: Bidder is an individual resident vendor who is a veteran of the United States armed forces, the reserves or the National Guard and has resided in West Virginia continuously for the four years immediately preceding the date on which the bid is submitted; or,
6. Application is made for 3.5% resident vendor preference who is a veteran for the reason checked: Bidder is a resident vendor who is a veteran of the United States armed forces, the reserves or the National Guard, if, for purposes of producing or distributing the commodities or completing the project which is the subject of the vendor's bid and continuously over the entire term of the project, on average at least seventy-five percent of the vendor's employees are residents of West Virginia who have resided in the state continuously for the two immediately preceding years.

Bidder understands if the Secretary of Revenue determines that a Bidder receiving preference has failed to continue to meet the requirements for such preference, the Secretary may order the Director of Purchasing to: (a) reject the bid; or (b) assess a penalty against such Bidder in an amount not to exceed 5% of the bid amount and that such penalty will be paid to the contracting agency or deducted from any unpaid balance on the contract or purchase order.

By submission of this certificate, Bidder agrees to disclose any reasonably requested information to the Purchasing Division and authorizes the Department of Revenue to disclose to the Director of Purchasing appropriate information verifying that Bidder has paid the required business taxes, provided that such information does not contain the amounts of taxes paid nor any other information deemed by the Tax Commissioner to be confidential.

Under penalty of law for false swearing (West Virginia Code, §61-5-3), Bidder hereby certifies that this certificate is true and accurate in all respects; and that if a contract is issued to Bidder and if anything contained within this certificate changes during the term of the contract, Bidder will notify the Purchasing Division in writing immediately.

Bidder: _____ Signed: _____

Date: _____ Title: _____

*Check any combination of preference consideration(s) indicated above, which you are entitled to receive.

STATE OF WEST VIRGINIA
Purchasing Division**PURCHASING AFFIDAVIT****VENDOR OWING A DEBT TO THE STATE:**

West Virginia Code §5A-3-10a provides that: No contract or renewal of any contract may be awarded by the state or any of its political subdivisions to any vendor or prospective vendor when the vendor or prospective vendor or a related party to the vendor or prospective vendor is a debtor and the debt owed is an amount greater than one thousand dollars in the aggregate.

PUBLIC IMPROVEMENT CONTRACTS & DRUG-FREE WORKPLACE ACT:

If this is a solicitation for a public improvement construction contract, the vendor, by its signature below, affirms that it has a written plan for a drug-free workplace policy in compliance with Article 1D, Chapter 21 of the *West Virginia Code*. The vendor **must** make said affirmation with its bid submission. Further, public improvement construction contract may not be awarded to a vendor who does not have a written plan for a drug-free workplace policy in compliance with Article 1D, Chapter 21 of the *West Virginia Code* and who has not submitted that plan to the appropriate contracting authority in timely fashion. For a vendor who is a subcontractor, compliance with Section 5, Article 1D, Chapter 21 of the *West Virginia Code* may take place before their work on the public improvement is begun.

ANTITRUST:

In submitting a bid to any agency for the state of West Virginia, the bidder offers and agrees that if the bid is accepted the bidder will convey, sell, assign or transfer to the state of West Virginia all rights, title and interest in and to all causes of action it may now or hereafter acquire under the antitrust laws of the United States and the state of West Virginia for price fixing and/or unreasonable restraints of trade relating to the particular commodities or services purchased or acquired by the state of West Virginia. Such assignment shall be made and become effective at the time the purchasing agency tenders the initial payment to the bidder.

I certify that this bid is made without prior understanding, agreement, or connection with any corporation, firm, limited liability company, partnership or person or entity submitting a bid for the same materials, supplies, equipment or services and is in all respects fair and without collusion or fraud. I further certify that I am authorized to sign the certification on behalf of the bidder or this bid.

LICENSING:

Vendors must be licensed and in good standing in accordance with any and all state and local laws and requirements by any state or local agency of West Virginia, including, but not limited to, the West Virginia Secretary of State's Office, the West Virginia Tax Department, West Virginia Insurance Commission, or any other state agencies or political subdivision. Furthermore, the vendor must provide all necessary releases to obtain information to enable the Director or spending unit to verify that the vendor is licensed and in good standing with the above entities.

CONFIDENTIALITY:

The vendor agrees that he or she will not disclose to anyone, directly or indirectly, any such personally identifiable information or other confidential information gained from the agency, unless the individual who is the subject of the information consents to the disclosure in writing or the disclosure is made pursuant to the agency's policies, procedures and rules. Vendor further agrees to comply with the Confidentiality Policies and Information Security Accountability Requirements, set forth in <http://www.state.wv.us/admin/purchase/privacy/noticeConfidentiality.pdf>.

Under penalty of law for false swearing (*West Virginia Code* §61-5-3), it is hereby certified that the vendor affirms and acknowledges the information in this affidavit and is in compliance with the requirements as stated.

Vendor's Name: _____

Authorized Signature: _____ Date: _____