



State of West Virginia
 Department of Administration
 Purchasing Division
 2019 Washington Street East
 Post Office Box 50130
 Charleston, WV 25305-0130

Request for Quotation

RFQ NUMBER
709C0017

PAGE
1

ADDRESS CORRESPONDENCE TO ATTENTION OF:
MICHAEL AUSTIN 304-558-2402

VENDOR

RFQ COPY
 TYPE NAME/ADDRESS HERE

SHIP TO

DIVISION OF HIGHWAYS
 VARIOUS LOCALES AS INDICATED
 BY ORDER

DATE PRINTED	TERMS OF SALE	SHIP VIA	F.O.B.	FREIGHT TERMS
03/25/2009				

BID OPENING DATE: **04/08/2009** BID OPENING TIME **01:30PM**

LINE	QUANTITY	UOP	CAT. NO.	ITEM NUMBER	UNIT PRICE	AMOUNT
0001	1	EA		557-70		
CONTRACT/ABOVE GROUND STORAGE TANKS AND ACCESSORIES OPEN END CONTRACT TO PROVIDE ABOVE GROUND STORAGE TANKS AND ACCESSORIES AS REQUIRED BY THE WEST VIRGINIA DIVISION OF HIGHWAYS. PER THE ATTACHED SPECIFICATIONS AND DRAWINGS. THE EQUIPMENT DIVISION'S ESTIMATED USAGE. 5 - 330 GALLON TANK 5 - 350 GALLON TANK 1 - 5000 GALLON TANK 5 - 10,000 GALLON TANK 1 - 20,000 GALLON TANK 14 - PUMP/DISPENSERS PURCHASING CARD ACCEPTANCE: THE STATE OF WEST VIRGINIA CURRENTLY UTILIZES A VISA PURCHASING CARD PROGRAM WHICH IS ISSUED THROUGH A BANK. THE SUCCESSFUL VENDOR MUST ACCEPT THE STATE OF WEST VIRGINIA VISA PURCHASING CARD FOR PAYMENT OF ALL ORDERS PLACED BY ANY STATE AGENCY AS A CONDITION OF AWARD. EXHIBIT 3 LIFE OF CONTRACT: THIS CONTRACT BECOMES EFFECTIVE ON AND EXTENDS FOR A PERIOD OF ONE (1						

SEE REVERSE SIDE FOR TERMS AND CONDITIONS			
SIGNATURE	TELEPHONE	DATE	
TITLE	FEIN	ADDRESS CHANGES TO BE NOTED ABOVE	

WHEN RESPONDING TO RFQ, INSERT NAME AND ADDRESS IN SPACE ABOVE LABELED 'VENDOR'

GENERAL TERMS & CONDITIONS
REQUEST FOR QUOTATION (RFQ) AND REQUEST FOR PROPOSAL (RFP)

1. Awards will be made in the best interest of the State of West Virginia.
2. The State may accept or reject in part, or in whole, any bid.
3. All quotations are governed by the *West Virginia Code* and the *Legislative Rules* of the Purchasing Division.
4. Prior to any award, the apparent successful vendor must be properly registered with the Purchasing Division and have paid the required \$125 fee.
5. All services performed or goods delivered under State Purchase Order/Contracts are to be continued for the term of the Purchase Order/Contracts, contingent upon funds being appropriated by the Legislature or otherwise being made available. In the event funds are not appropriated or otherwise available for these services or goods, this Purchase Order/Contract becomes void and of no effect after June 30.
6. Payment may only be made after the delivery and acceptance of goods or services.
7. Interest may be paid for late payment in accordance with the *West Virginia Code*.
8. Vendor preference will be granted upon written request in accordance with the *West Virginia Code*.
9. The State of West Virginia is exempt from federal and state taxes and will not pay or reimburse such taxes.
10. The Director of Purchasing may cancel any Purchase Order/Contract upon 30 days written notice to the seller.
11. The laws of the State of West Virginia and the *Legislative Rules* of the Purchasing Division shall govern all rights and duties under the Contract, including without limitation the validity of this Purchase Order/Contract.
12. Any reference to automatic renewal is hereby deleted. The Contract may be renewed only upon mutual written agreement of the parties.
13. **BANKRUPTCY:** In the event the vendor/contractor files for bankruptcy protection, this Contract may be deemed null and void, and terminated without further order.
14. **HIPAA BUSINESS ASSOCIATE ADDENDUM:** The West Virginia State Government HIPAA Business Associate Addendum (BAA), approved by the Attorney General, and available online at the Purchasing Division's web site (<http://www.state.wv.us/admin/purchase/vrc/hipaa.htm>) is hereby made part of the agreement. Provided that, the Agency meets the definition of a Cover Entity (45 CFR §160.103) and will be disclosing Protected Health Information (45 CFR §160.103) to the vendor.
15. **WEST VIRGINIA ALCOHOL & DRUG-FREE WORKPLACE ACT:** If this Contract constitutes a public improvement construction contract as set forth in Article 1D, Chapter 21 of the West Virginia Code ("The West Virginia Alcohol and Drug-Free Workplace Act"), then the following language shall hereby become part of this Contract: "The contractor and its subcontractors shall implement and maintain a written drug-free workplace policy in compliance with the West Virginia Alcohol and Drug-Free Workplace Act, as set forth in Article 1D, Chapter 21 of the West Virginia Code. The contractor and its subcontractors shall provide a sworn statement in writing, under the penalties of perjury, that they maintain a valid drug-free work place policy in compliance with the West Virginia and Drug-Free Workplace Act. It is understood and agreed that this Contract shall be cancelled by the awarding authority if the Contractor: 1) Fails to implement its drug-free workplace policy; 2) Fails to provide information regarding implementation of the contractor's drug-free workplace policy at the request of the public authority; or 3) Provides to the public authority false information regarding the contractor's drug-free workplace policy."

INSTRUCTIONS TO BIDDERS

1. Use the quotation forms provided by the Purchasing Division.
2. **SPECIFICATIONS:** Items offered must be in compliance with the specifications. Any deviation from the specifications must be clearly indicated by the bidder. Alternates offered by the bidder as **EQUAL** to the specifications must be clearly defined. A bidder offering an alternate should attach complete specifications and literature to the bid. The Purchasing Division may waive minor deviations to specifications.
3. Complete all sections of the quotation form.
4. Unit prices shall prevail in case of discrepancy.
5. All quotations are considered F.O.B. destination unless alternate shipping terms are clearly identified in the quotation.
6. **BID SUBMISSION:** All quotations must be delivered by the bidder to the office listed below prior to the date and time of the bid opening. Failure of the bidder to deliver the quotations on time will result in bid disqualifications: Department of Administration, Purchasing Division, 2019 Washington Street East, P.O. Box 50130, Charleston, WV 25305-0130



State of West Virginia
 Department of Administration
 Purchasing Division
 2019 Washington Street East
 Post Office Box 50130
 Charleston, WV 25305-0130

Request for Quotation

RFQ NUMBER
 709C0017

PAGE
 2

ADDRESS CORRESPONDENCE TO ATTENTION OF
 MICHAEL AUSTIN
 304-558-2402

RFQ COPY
 TYPE NAME/ADDRESS HERE

V
E
N
D
O
R

S
H
I
P
T
O

DIVISION OF HIGHWAYS
 VARIOUS LOCALES AS INDICATED
 BY ORDER

DATE PRINTED	TERMS OF SALE	SHIP VIA	F.O.B.	FREIGHT TERMS
03/25/2009				

BID OPENING DATE: 04/08/2009 BID OPENING TIME 01:30PM

LINE	QUANTITY	UOP	CAT NO	ITEM NUMBER	UNIT PRICE	AMOUNT
<p>YEAR OR UNTIL SUCH "REASONABLE TIME" THEREAFTER AS IS NECESSARY TO OBTAIN A NEW CONTRACT OR RENEW THE ORIGINAL CONTRACT. THE "REASONABLE TIME" PERIOD SHALL NOT EXCEED TWELVE (12) MONTHS. DURING THIS "REASONABLE TIME" THE VENDOR MAY TERMINATE THIS CONTRACT FOR ANY REASON UPON GIVING THE DIRECTOR OF PURCHASING 30 DAYS WRITTEN NOTICE.</p> <p>UNLESS SPECIFIC PROVISIONS ARE STIPULATED ELSEWHERE IN THIS CONTRACT DOCUMENT, THE TERMS, CONDITIONS AND PRICING SET HEREIN ARE FIRM FOR THE LIFE OF THE CONTRACT.</p> <p>RENEWAL: THIS CONTRACT MAY BE RENEWED UPON THE MUTUAL WRITTEN CONSENT OF THE SPENDING UNIT AND VENDOR, SUBMITTED TO THE DIRECTOR OF PURCHASING THIRTY (30) DAYS PRIOR TO THE EXPIRATION DATE. SUCH RENEWAL SHALL BE IN ACCORDANCE WITH THE TERMS AND CONDITIONS OF THE ORIGINAL CONTRACT AND SHALL BE LIMITED TO TWO (2) ONE (1) YEAR PERIODS.</p> <p>CANCELLATION: THE DIRECTOR OF PURCHASING RESERVES THE RIGHT TO CANCEL THIS CONTRACT IMMEDIATELY UPON WRITTEN NOTICE TO THE VENDOR IF THE COMMODITIES AND/OR SERVICE SUPPLIED ARE OF AN INFERIOR QUALITY OR DO NOT CONFORM TO THE SPECIFICATIONS OF THE BID AND CONTRACT HEREIN.</p> <p>OPEN MARKET CLAUSE: THE DIRECTOR OF PURCHASING MAY AUTHORIZE A SPENDING UNIT TO PURCHASE ON THE OPEN MARKET, WITHOUT THE FILING OF A REQUISITION OR COST ESTIMATE, ITEMS SPECIFIED ON THIS CONTRACT FOR IMMEDIATE DELIVERY IN EMERGENCIES DUE TO UNFORESEEN CAUSES (INCLUDING BUT NOT LIMITED TO DELAYS IN TRANSPORTATION OR AN UNANTICIPATED INCREASE IN THE VOLUME OF WORK.)</p>						

SEE REVERSE SIDE FOR TERMS AND CONDITIONS

SIGNATURE	TELEPHONE	DATE
TITLE	FEIN	ADDRESS CHANGES TO BE NOTED ABOVE

WHEN RESPONDING TO RFQ, INSERT NAME AND ADDRESS IN SPACE ABOVE LABELED 'VENDOR'



State of West Virginia
 Department of Administration
 Purchasing Division
 2019 Washington Street East
 Post Office Box 50130
 Charleston, WV 25305-0130

Request for Quotation

RFQ NUMBER
709C0017

PAGE
3

ADDRESS CORRESPONDENCE TO ATTENTION OF
MICHAEL AUSTIN 304-558-2402

RFQ COPY
 TYPE NAME/ADDRESS HERE

VENDOR

SHIP TO

DIVISION OF HIGHWAYS
 VARIOUS LOCALES AS INDICATED
 BY ORDER

DATE PRINTED	TERMS OF SALE	SHIP VIA	F.O.B.	FREIGHT TERMS
03/25/2009				

BID OPENING DATE: 04/08/2009 BID OPENING TIME 01:30PM

LINE	QUANTITY	UOP	CAT NO	ITEM NUMBER	UNIT PRICE	AMOUNT
<p>QUANTITIES: QUANTITIES LISTED IN THE REQUISITION ARE APPROXIMATIONS ONLY, BASED ON ESTIMATES SUPPLIED BY THE STATE SPENDING UNIT. IT IS UNDERSTOOD AND AGREED THAT THE CONTRACT SHALL COVER THE QUANTITIES ACTUALLY ORDERED FOR DELIVERY DURING THE TERM OF THE CONTRACT, WHETHER MORE OR LESS THAN THE QUANTITIES SHOWN.</p> <p>ORDERING PROCEDURE: SPENDING UNIT(S) SHALL ISSUE A WRITTEN STATE CONTRACT ORDER (FORM NUMBER WV-39) TO THE VENDOR FOR COMMODITIES COVERED BY THIS CONTRACT. THE ORIGINAL COPY OF THE WV-39 SHALL BE MAILED TO THE VENDOR AS AUTHORIZATION FOR SHIPMENT, A SECOND COPY MAILED TO THE PURCHASING DIVISION, AND A THIRD COPY RETAINED BY THE SPENDING UNIT.</p> <p>BANKRUPTCY: IN THE EVENT THE VENDOR/CONTRACTOR FILES FOR BANKRUPTCY PROTECTION, THIS CONTRACT IS AUTOMATICALLY NULL AND VOID, AND IS TERMINATED WITHOUT FURTHER ORDER.</p> <p>THE TERMS AND CONDITIONS CONTAINED IN THIS CONTRACT SHALL SUPERSEDE ANY AND ALL SUBSEQUENT TERMS AND CONDITIONS WHICH MAY APPEAR ON ANY ATTACHED PRINTED DOCUMENTS SUCH AS PRICE LISTS, ORDER FORMS, SALES AGREEMENTS OR MAINTENANCE AGREEMENTS, INCLUDING ANY ELECTRONIC MEDIUM SUCH AS CD-ROM.</p> <p>REV. 04/11/2001</p> <p>EXHIBIT 10</p> <p style="text-align: right;">REQUISITION NO.:</p> <p>ADDENDUM ACKNOWLEDGEMENT</p>						

SEE REVERSE SIDE FOR TERMS AND CONDITIONS

SIGNATURE	TELEPHONE	DATE
TITLE	FEIN	ADDRESS CHANGES TO BE NOTED ABOVE

WHEN RESPONDING TO RFQ, INSERT NAME AND ADDRESS IN SPACE ABOVE LABELED 'VENDOR'



State of West Virginia
 Department of Administration
 Purchasing Division
 2019 Washington Street East
 Post Office Box 50130
 Charleston, WV 25305-0130

Request for Quotation

RFQ NUMBER
709C0017

PAGE
4

ADDRESS CORRESPONDENCE TO ATTENTION OF:
MICHAEL AUSTIN 304-558-2402

VENDOR

RFQ COPY
 TYPE NAME/ADDRESS HERE

SHIP TO

DIVISION OF HIGHWAYS
 VARIOUS LOCALES AS INDICATED
 BY ORDER

DATE PRINTED	TERMS OF SALE	SHIP VIA	F.O.B.	FREIGHT TERMS
03/25/2009				

BID OPENING DATE: 04/08/2009 BID OPENING TIME 01:30PM

LINE	QUANTITY	UOP	CAT NO	ITEM NUMBER	UNIT PRICE	AMOUNT
<p>I HEREBY ACKNOWLEDGE RECEIPT OF THE FOLLOWING CHECKED ADDENDUM(S) AND HAVE MADE THE NECESSARY REVISIONS TO MY PROPOSAL, PLANS AND/OR SPECIFICATION, ETC.</p> <p>ADDENDUM NO.'S:</p> <p>NO. 1</p> <p>NO. 2</p> <p>NO. 3</p> <p>NO. 4</p> <p>NO. 5</p> <p>I UNDERSTAND THAT FAILURE TO CONFIRM THE RECEIPT OF THE ADDENDUM(S) MAY BE CAUSE FOR REJECTION OF BIDS.</p> <p>VENDOR MUST CLEARLY UNDERSTAND THAT ANY VERBAL REPRESENTATION MADE OR ASSUMED TO BE MADE DURING ANY ORAL DISCUSSION HELD BETWEEN VENDOR'S REPRESENTATIVES AND ANY STATE PERSONNEL IS NOT BINDING. ONLY THE INFORMATION ISSUED IN WRITING AND ADDED TO THE SPECIFICATIONS BY AN OFFICIAL ADDENDUM IS BINDING.</p> <p>..... SIGNATURE</p> <p>..... COMPANY</p> <p>..... DATE</p>						

SEE REVERSE SIDE FOR TERMS AND CONDITIONS

SIGNATURE	TELEPHONE	DATE
TITLE	FEIN	ADDRESS CHANGES TO BE NOTED ABOVE

WHEN RESPONDING TO RFQ, INSERT NAME AND ADDRESS IN SPACE ABOVE LABELED 'VENDOR'



State of West Virginia
 Department of Administration
 Purchasing Division
 2019 Washington Street East
 Post Office Box 50130
 Charleston, WV 25305-0130

Request for Quotation

RFQ NUMBER
709C0017

PAGE
5

ADDRESS CORRESPONDENCE TO ATTENTION OF:
MICHAEL AUSTIN
304-558-2402

VENDOR

RFQ COPY
 TYPE NAME/ADDRESS HERE

SHIP TO

DIVISION OF HIGHWAYS
 VARIOUS LOCALES AS INDICATED
 BY ORDER

DATE PRINTED	TERMS OF SALE	SHIP VIA	F.O.B.	FREIGHT TERMS
03/25/2009				

BID OPENING DATE: **04/08/2009** BID OPENING TIME **01:30PM**

LINE	QUANTITY	UOP	CAT. NO.	ITEM NUMBER	UNIT PRICE	AMOUNT
	REV. 11/96					
<p>NOTICE</p> <p>A SIGNED BID MUST BE SUBMITTED TO:</p> <p>DEPARTMENT OF ADMINISTRATION PURCHASING DIVISION BUILDING 15 2019 WASHINGTON STREET, EAST CHARLESTON, WV 25305-0130</p> <p>THE BID SHOULD CONTAIN THIS INFORMATION ON THE FACE OF THE ENVELOPE OR THE BID MAY NOT BE CONSIDERED:</p> <p>SEALED BID</p> <p>BUYER: 33</p> <p>RFQ. NO.: 709C0017-----</p> <p>BID OPENING DATE: -----</p> <p>BID OPENING TIME: -----</p> <p>PLEASE PROVIDE A FAX NUMBER IN CASE IT IS NECESSARY TO CONTACT YOU REGARDING YOUR BID:</p> <p>-----</p> <p>CONTACT PERSON (PLEASE PRINT CLEARLY):</p>						

SEE REVERSE SIDE FOR TERMS AND CONDITIONS

SIGNATURE	TELEPHONE	DATE
TITLE	FEIN	ADDRESS CHANGES TO BE NOTED ABOVE

WHEN RESPONDING TO RFQ, INSERT NAME AND ADDRESS IN SPACE ABOVE LABELED 'VENDOR'



State of West Virginia
 Department of Administration
 Purchasing Division
 2019 Washington Street East
 Post Office Box 50130
 Charleston, WV 25305-0130

Request for Quotation

RFQ NUMBER
709C0017

PAGE
6

ADDRESS CORRESPONDENCE TO ATTENTION OF:
MICHAEL AUSTIN 304-558-2402

RFQ COPY
 TYPE NAME/ADDRESS HERE

VENDOR

SHIP TO

DIVISION OF HIGHWAYS
 VARIOUS LOCALES AS INDICATED
 BY ORDER

DATE PRINTED	TERMS OF SALE	SHIP VIA	F.O.B.	FREIGHT TERMS
03/25/2009				

BID OPENING DATE: 04/08/2009 BID OPENING TIME 01:30PM

LINE	QUANTITY	UOP	CAT NO.	ITEM NUMBER	UNIT PRICE	AMOUNT

***** THIS IS THE END OF RFQ 709C0017 ***** TOTAL:						_____

SEE REVERSE SIDE FOR TERMS AND CONDITIONS

SIGNATURE	TELEPHONE	DATE
TITLE	FEIN	ADDRESS CHANGES TO BE NOTED ABOVE

WHEN RESPONDING TO RFQ, INSERT NAME AND ADDRESS IN SPACE ABOVE LABELED 'VENDOR'

1. 330 GALLON DOUBLE WALL LUBRICANT TANK UL-142
 (VERTICAL, HORIZONTAL, UPRIGHT)
 OVAL DIMENTION APPROXAMATLY
 6'3" LONG
 2'3" WIDE
 3'8" DEEP
 SHALL BE DOUBLE WALL CONSTRUCTED OF 12 GAUGE STEEL
 TANK SHALL INCLUDE:
 4) 2" THREADED CONNECTIONS
 1) 3" THREADED CONNECTIONS
 1) ½" THREADED CONNECTIONS
 SHALL INCLUDE THREADED PIPE SUPPORT LEGS WITH FLOOR
 FLANGES.
 TANK COATING, MEDIA BLAST, EPOXY PRIMER, WHITE URETHANE
 PAINT.

PICK UP COST		DELIVERED COST	
UNIT PRICE	AMOUNT	UNIT PRICE	AMOUNT

2. 350 GALLON DOUBLE WALL LUBRICANT TANK UL-142
 RECTANGULAR DIMENTIONS APPROXAMATLY
 5'1.5" LONG
 3'6.5" WIDE
 2'8.5" DEEP
 DOUBLE WALL TANK SHALL BE OF ALL WELDED
 CONSTRUCTION,FABRICATED OF 12 GAUGE THICK MILD CARBON
 STEEL FOR THE INNER TANK.
 STANDARD CONSTRUCTION UTILIZES LAP JOINTS WITH CONTINUOUS
 FILLET WELD ON ALL OUTSIDE SEAMS ONLY.
 TANK SHALL INCLUDE:
 5) 2" FORGED STEEL FITTING
 1) 4" OR 6" FORGED STEEL FITTING OR AN 18" LOOSE BOLT MANHOLE
 FOR EMERGENCY VENTING.
 FABRICATION SHALL INCLUDE 2" HIGH SUPPORT WELDED TO THE
 TANK UNDERSIDE PROVIDING GROUND CLEARANCE FOR VISUAL
 INSPECTION.
 TANK COATING: MEDIA BLAST, EPOXY PRIMER, WHITE URETHANE
 PAINT.

PICK UP COST		DELIVERED COST	
UNIT PRICE	AMOUNT	UNIT PRICE	AMOUNT

- 3. 5000 GALLON ABOVE GROUND STORAGE TANK. TO INCLUDE
 - 8" HEAVY BEAM SKID
 - 24" MAN WAY
 - TYPE: DOUBLE WALL
 - MATERIAL: MILD CARBON STEEL
 - DIAMETER: 96" APPROX.
 - WEIGHT: 9650 lbs. APPROX.
 - 1 PUMP PLATFORM ATTACHED AND, 1 DISPENSER BRACKET ATTACHED
 - NPT OPENINGS: 1-8", 1-6", 4-4", 1-3", 1-2".
 - NPT SECONDARY EMERGENCY VENT OPENING 1-8", AND 1-2" MONITOR PIPE
 - PRIMARY EMERGENCY VENT 1-8", SECONDARY EMERGENCY VENT 1-8".
 - STANDARD MUSHROOM VENT CAP 1-3".
 - LADDER BRACKET BOTH ENDS
 - EXTERIOR COATING: MEDIA BLAST, EPOXY PRIMER, WHITE URETHANE PAINT

PICK UP COST		DELIVERED COST	
UNIT PRICE	AMOUNT	UNIT PRICE	AMOUNT
_____	_____	_____	_____

- 4. 10,000 GALLON ABOVE GROUND STORAGE TANK. TO INCLUDE
 - 8" HEAVY BEAM SKID
 - (1) -24" MAN WAY PER COMPARTMENT
 - TYPE: DOUBLE WALL WITH DOUBLE WALL BULKHEAD COMPARTED 5000/5000
 - MATERIAL: MILD CARBON STEEL
 - DIAMETER: 120" APPROX.
 - WEIGHT: 19,100 lbs. APPROX.
 - 2 PUMP PLATFORMS ATTACHED AND 3 DISPENSER BRACKETS ATTACHED
 - 2 ON SAME SIDE 1 ON OPPOSITE SIDE
 - NPT OPENINGS EACH COMPARTMENT 1-8", 1-6", 4-4", 1-3", 1-2"
 - NPT SECONDARY EMERGENCY VENT OPENINGS 1-8", AND 1-2" MONITOR PIPE
 - PRIMARY EMERGENCY VENT 1-8", SECONDARY EMERGENCY VENT 1-8"
 - PER COMPARTMENT
 - STANDARD MUSHROOM VENT CAP 1-3", PRESSURE VACUUM VENT CAP 1-3"
 - PER COMPARTMENT
 - LADDER BRACKET BOTH ENDS
 - EXTERIOR COATING: MEDIA BLAST, EPOXY PRIMER, WHITE URETHANE PAINT

PICK UP COST		DELIVERED COST	
UNIT PRICE	AMOUNT	UNIT PRICE	AMOUNT
_____	_____	_____	_____

- 5. 20,000 GAL. ABOVE GROUND STORAGE TANK TO INCLUDE THE FOLLOWING:
 8" HEAVY BEAM SKID
 (1)-24" MANWAY PER COMPARTMENT
 TYPE: DOUBLE WALL WITH DOUBLE WALL BULKHEAD, COMPARTED 10,000/10,000
 MATERIAL: MILD CARBON STEEL
 DIAMETER: 120" APPROX
 WEIGHT: 33,000 lbs. APPROX.
 2 PUMP PLATFORMS ATTACHED AND 3 DISPENSER BRACKETS ATTACHED
 (2) ON SAME SIDE (1) ON OPPOSITE.
 NPT OPENINGS EACH COMPARTMENT 1-8", 1-6", 4-4", 1-3", 1-2"
 NPT SECONDARY EMERGENCY VENT OPENING 1 - 10" AND 1-2" MONITOR PIPE
 PRIMARY EMERGENCY VENT 2-8", SECONDARY EMERGENCY VENT 1-10"
 PER COMPARTMENT.
 STANDARD MUSHROOM VENT CAP 1-3" PRESSURE VACUUM VENT CAP 1-3"
 PER COMPARTMENT.
 LADDER BRACKETS BOTH ENDS
 EXTERIOR COATING: MEDIA BLAST, EPOXY PRIMER, WHITE URETHANE PAINT

PICK UP COST		DELIVERED COST	
UNIT COST	AMOUNT	UNIT PRICE	AMOUNT
_____	_____	_____	_____

ALL TANKS SHALL MEET OR EXCEED UL 142, NFPA 30 AS WELL AS ANY OTHER FEDERAL OR STATE LAWS, RULES OR GUIDELINES.

ALL TANKS SHALL INCLUDE NECESSARY COMPONENTS AND HARDWARE TO PUT EACH PRODUCT IN SERVICE.

- 6. REMOTE FILL BOX TO INCLUDE 30-20GL-700B BAKER STAND OR EQUAL, 20 GALLON CONTAINMENT WITH VENT, DRAIN PORT, AND LOCKING DOOR, 3" CAM LOCK ADAPTER WITH CAP, 3" FULL PORT VALVE, 3"BRASS SWING CHECK, 3" x 6" MOR 9095A REMOTE BOTTOM FILL LIMITER VALVE OR EQUAL.

UNIT PRICE _____

- 7. MORRISON CLOCK GAUGE MODEL 818-0100AG (2") OR EQUAL

UNIT PRICE _____

- 8. LEAK DETECTION: 7880073-5 CHANNEL ALARM PANEL OR EQUAL, 2-LS-800 HIGH LEVEL PROBES WITH CAPS, 1-LS750 SECONDARY INTERSTICE LEAK SENSOR SHALL MEET OR EXCEED UL 142 AND NFPA 30.

UNIT PRICE _____

- 9. 108" STAIRWAY (2) OSHA COMPLIANT WITH LANDING AND HANDRAIL. BLAST AND COAT SAFETY YELLOW URETHANE, SHALL BOLT DIRECTLY TO TANK.

UNIT PRICE _____

- 10. 128" STAIRWAY (2) OSHA COMPLIANT WITH LANDING AND HANDRAIL. BLAST AND COAT SAFETY YELLOW URETHANE, SHALL BOLT DIRECTLY TO TANK.

UNIT COST _____

- 11. PUMP/DISPENSER: GASBOY 9823K, (21 GPM) OR EQUAL, TO INCLUDE THE FOLLOWING:
 PULSER BRACKET MOUNT KIT
 FILTER
 SOLENOID VALVE
 EXPANSION RELIEF VALVE
 HIGH HOSE RETRACTOR
 1" x 20' DIESEL HOSE OR 3/4" x 12' GAS HOSE AS SPECIFIED
 AUTO NOZZLE
 SWIVEL AND WHIP HOSE
 SAFE-T-BREAK (reconnectable) 1.5" SUCTION PIPING TO FACILITATE TANK DIAMETER.
 DISPENSE 21 GALLON PER MINUTE
 PULSE OUTPUT CARD TO MATCH FOR FUTURE INSTALLATION OF ASTRA FLEET KEY SYSTEM OR ISLANDER SYSTEM. TO BE DETERMINED AT TIME OF PURCHASE.

UNIT COST _____

THE VENDOR SHALL FURNISH ANY TECHNICAL ENGINEERING SERVICE WHICH MIGHT BE NEEDED IN THE PROPER INSTALLATION OF THESE ITEMS AT NO EXTRA COST TO THE WV DIVISION OF HIGHWAYS.

DOH WILL DETERMINE AT THE TIME OF ORDER IF TANK WILL BE PICKED UP BY DOH PERSONNEL OR DELIVERED TO DOH LOCATION.

DELIVERY LOCATIONS MAY INCLUDE AREAS IN THE FOLLOWING DISTRICTS:

- | | |
|---------------------------------|--------------------------|
| DISTRICT 1 - CHARLESTON | DISTRICT 6 - MOUNDSVILLE |
| DISTRICT 2 - HUNTINGTON | DISTRICT 7 - WESTON |
| DISTRICT 3 - PARKERSBURG | DISTRICT 8 - ELKINS |
| DISTRICT 4 - CLARKSBURG | DISTRICT 9 - LEWISBURG |
| DISTRICT 5 - BURLINGTON | DISTRICT 10 - PRINCETON |
| EQUIPMENT DIVISION - BUCKHANNON | |

CONTRACT WILL BE AWARDED ON DELIVERED COST OF COMPLETE UNIT INCLUDING ACCESSORIES.

330 GAL LUBE TANK

General Arrangement

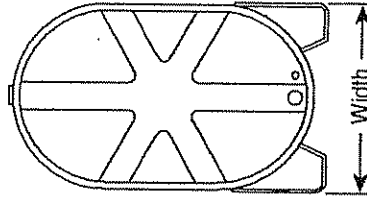
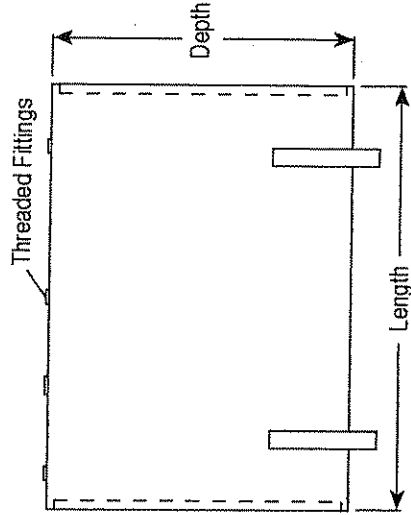
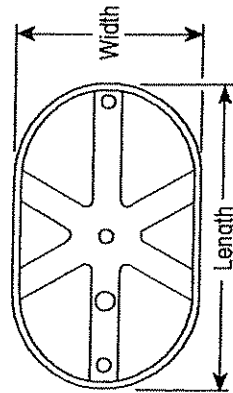
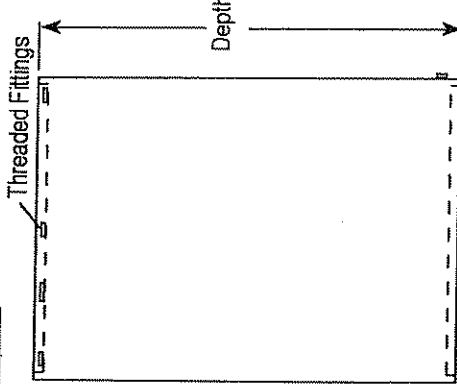

NOTE: ALL FITTINGS MUST BE THE SAME TYPE AND SIZE AS SHOWN IN THIS DRAWING. THE FABRICATOR SHALL BE RESPONSIBLE FOR THE PROPER INSTALLATION OF THE TANK. THE CUSTOMER IS RESPONSIBLE FOR THE PROPER LOCATION OF THE TANK AND THE PROPER SUPPORTS. THE FABRICATOR SHALL BE RESPONSIBLE FOR THE PROPER LOCATION OF THE TANK AND THE PROPER SUPPORTS. THE CUSTOMER IS RESPONSIBLE FOR THE PROPER LOCATION OF THE TANK AND THE PROPER SUPPORTS.

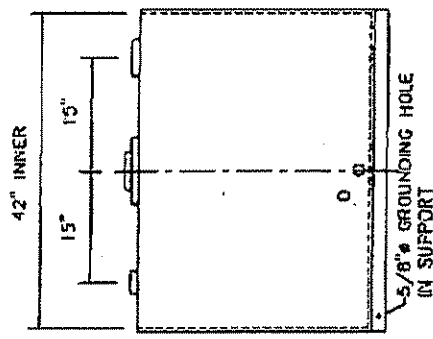
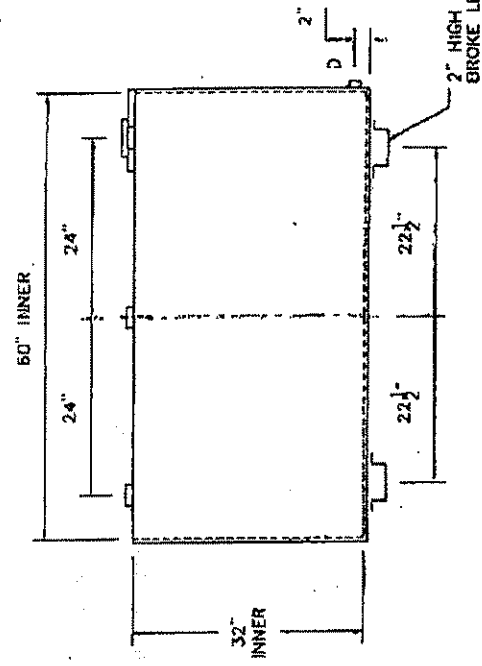
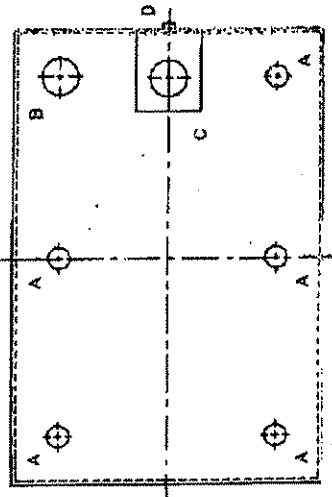

DESIGN DATA	
CAPACITY	- 350 GALLONS
TYPE	- DOUBLE WALL - TYPE I
NO. REQ.	-
OPERATING PRESSURE	- ATMOSPHERIC
TANK MATERIAL	- MILD CARBON STEEL
THICKNESS - INNER	- 12 GAUGE
THICKNESS - OUTER	- 12 GAUGE
CONSTRUCTION	- INNER - LAP WELD OUTSIDE ONLY OUTER - LAP WELD OUTSIDE ONLY
TANK TEST	- INNER - 2 PSIG OUTER - 2 PSIG AND FULL VACUUM
INT. FINISH	- NONE
EXT. FINISH	- SHOP PRIMER
LABEL	- UL 142
LEGEND	
A	2" FITTING
B	4" FITTING
C	4" FITTING MOUNTED IN INTERFERENCE EXTENSION; BO MARK WITH LABEL - SECONDARY EMERGENCY VENT US
D	1/2" FITTING THROUGH OUTER SHELL ONLY WITH BUTYON SITE GLASS
E	-
F	-

No. 7383 P.

350 GAL D W LUBE TANK

CUSTOMER: _____

PROJECT: _____

QUOTE NO: _____

DATE: _____

BY: _____

CHKD BY: _____

DATE: _____

DLSSO

Capacity 5,000 Gallons Heads Primary 1/4" Paint Ext. White Urethane
 Design Doublewall Beamskid Shell Primary 1/4" Paint Int. _____
 Code UL 142 Flameshield Heads Secondary 1/4" Weight Empty 9,650 lbs.
 Test Pres. 5 PSI Shell Secondary 10 Gauge Rev.# _____ Date: _____

Tank For Stationary Use Only

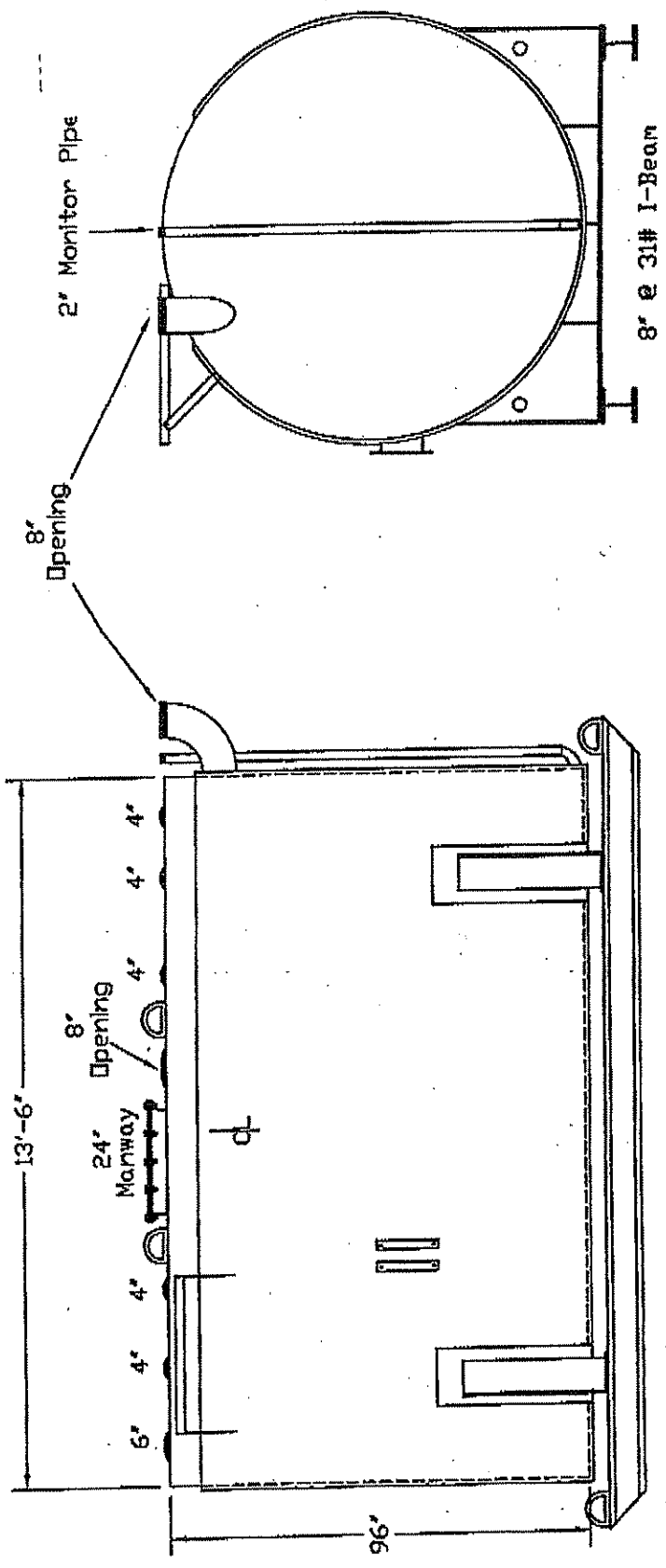

Capacity 10,000 Gallons Heads Primary 1/4" Paint Ext. White Urethane
 Design Aboveground DW Shell Primary 1/4" Paint Int. _____
 Code UL 142 Flareshield Heads Secondary 1/4" Weight Empty 19,100 lbs.
 Test Pres. 5 PSI Shell Secondary 7 Gauge Rev.# _____ Date: _____

Tank For Stationary Use Only

36"x36" Pump Platform
 Both ends of tank

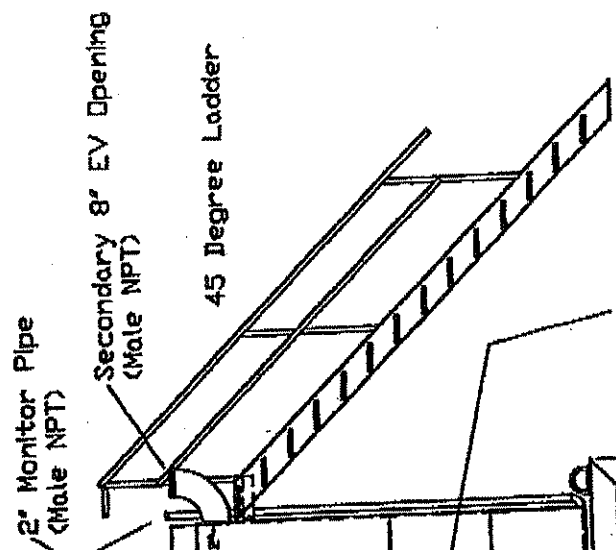
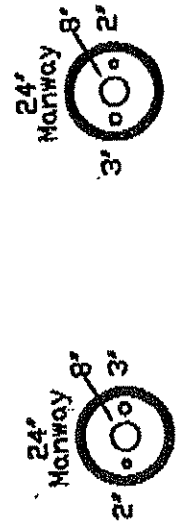

2-Compartment
 5000 x 5000
 Double Bulkhead

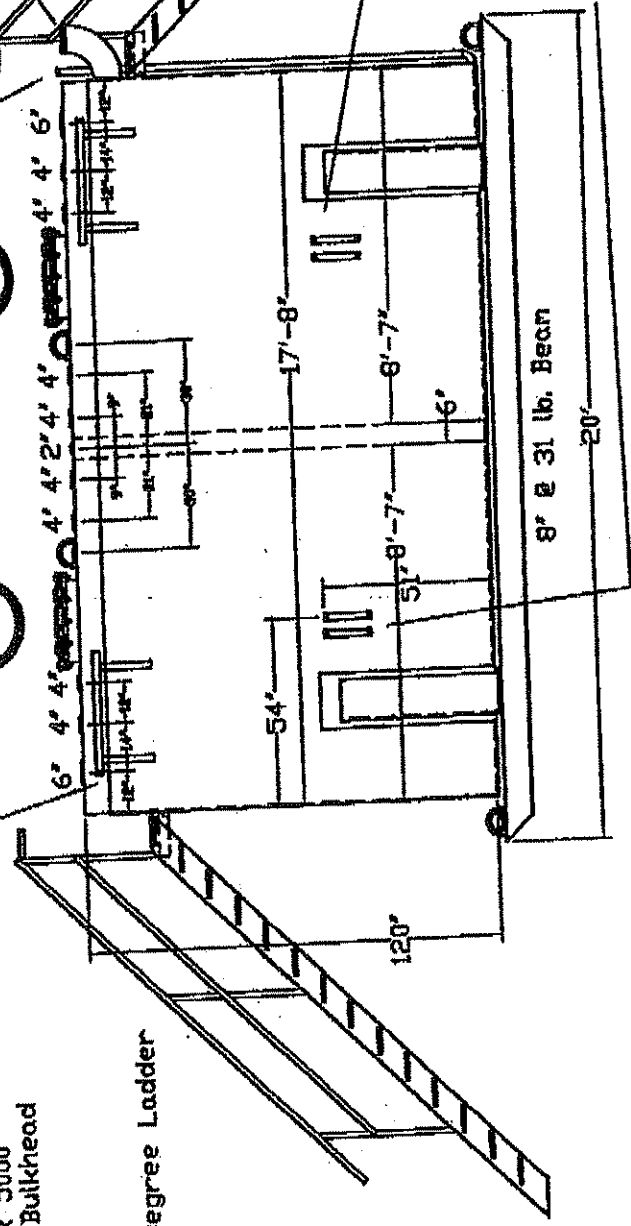

Two Astra Brackets on Front
 Side, and One Astra Bracket on
 Back Side

Generic Configuration Drawing

Capacity 20000 Gallon
 Design Dual Wall AG
 Code UL142 Flameshield
 Test Pres. 5 PSI
 Heads Primary 5/16
 Secondary 1/4
 Shell Primary 1/4
 Secondary 7 Ga.
 Paint Ext. White Urethane
 Paint Int. _____
 Weight Empty 33,000#
 Drawing # _____
 Scale None
 Spec. Notes _____

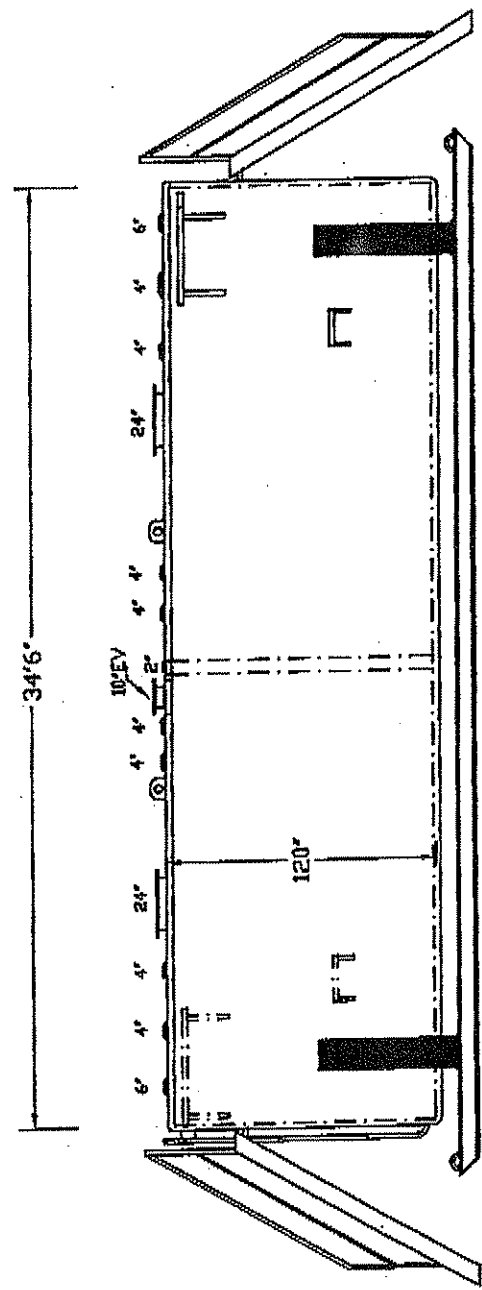

2 Compartment
 10000 x 10000
 Double Bulkhead

VENDOR PREFERENCE CERTIFICATE

Certification and application* is hereby made for Preference in accordance with West Virginia Code, §5A-3-37. (Does not apply to construction contracts). West Virginia Code, §5A-3-37, provides an opportunity for qualifying vendors to request (at the time of bid) preference for their residency status. Such preference is an evaluation method only and will be applied only to the cost bid in accordance with the West Virginia Code. This certificate for application is to be used to request such preference. The Purchasing Division will make the determination of the Resident Vendor Preference, if applicable.

- 1. Application is made for 2.5% resident vendor preference for the reason checked: Bidder is an individual resident vendor and has resided continuously in West Virginia for four (4) years immediately preceding the date of this certification; or, Bidder is a partnership, association or corporation resident vendor and has maintained its headquarters or principal place of business continuously in West Virginia for four (4) years immediately preceding the date of this certification; or 80% of the ownership interest of Bidder is held by another individual, partnership, association or corporation resident vendor who has maintained its headquarters or principal place of business continuously in West Virginia for four (4) years immediately preceding the date of this certification; or, Bidder is a nonresident vendor which has an affiliate or subsidiary which employs a minimum of one hundred state residents and which has maintained its headquarters or principal place of business within West Virginia continuously for the four (4) years immediately preceding the date of this certification; or,
2. Application is made for 2.5% resident vendor preference for the reason checked: Bidder is a resident vendor who certifies that, during the life of the contract, on average at least 75% of the employees working on the project being bid are residents of West Virginia who have resided in the state continuously for the two years immediately preceding submission of this bid; or,
3. Application is made for 2.5% resident vendor preference for the reason checked: Bidder is a nonresident vendor employing a minimum of one hundred state residents or is a nonresident vendor with an affiliate or subsidiary which maintains its headquarters or principal place of business within West Virginia employing a minimum of one hundred state residents who certifies that, during the life of the contract, on average at least 75% of the employees or Bidder's affiliate's or subsidiary's employees are residents of West Virginia who have resided in the state continuously for the two years immediately preceding submission of this bid; or,
4. Application is made for 5% resident vendor preference for the reason checked: Bidder meets either the requirement of both subdivisions (1) and (2) or subdivision (1) and (3) as stated above; or,
5. Application is made for 3.5% resident vendor preference who is a veteran for the reason checked: Bidder is an individual resident vendor who is a veteran of the United States armed forces, the reserves or the National Guard and has resided in West Virginia continuously for the four years immediately preceding the date on which the bid is submitted; or,
6. Application is made for 3.5% resident vendor preference who is a veteran for the reason checked: Bidder is a resident vendor who is a veteran of the United States armed forces, the reserves or the National Guard, if, for purposes of producing or distributing the commodities or completing the project which is the subject of the vendor's bid and continuously over the entire term of the project, on average at least seventy-five percent of the vendor's employees are residents of West Virginia who have resided in the state continuously for the two immediately preceding years.

Bidder understands if the Secretary of Revenue determines that a Bidder receiving preference has failed to continue to meet the requirements for such preference, the Secretary may order the Director of Purchasing to: (a) reject the bid; or (b) assess a penalty against such Bidder in an amount not to exceed 5% of the bid amount and that such penalty will be paid to the contracting agency or deducted from any unpaid balance on the contract or purchase order.

By submission of this certificate, Bidder agrees to disclose any reasonably requested information to the Purchasing Division and authorizes the Department of Revenue to disclose to the Director of Purchasing appropriate information verifying that Bidder has paid the required business taxes, provided that such information does not contain the amounts of taxes paid nor any other information deemed by the Tax Commissioner to be confidential.

Under penalty of law for false swearing (West Virginia Code, §61-5-3), Bidder hereby certifies that this certificate is true and accurate in all respects; and that if a contract is issued to Bidder and if anything contained within this certificate changes during the term of the contract, Bidder will notify the Purchasing Division in writing immediately.

Bidder: _____ Signed: _____

Date: _____ Title: _____

*Check any combination of preference consideration(s) indicated above, which you are entitled to receive.

STATE OF WEST VIRGINIA
Purchasing Division

PURCHASING AFFIDAVIT

VENDOR OWING A DEBT TO THE STATE:

West Virginia Code §5A-3-10a provides that: No contract or renewal of any contract may be awarded by the state or any of its political subdivisions to any vendor or prospective vendor when the vendor or prospective vendor or a related party to the vendor or prospective vendor is a debtor and the debt owed is an amount greater than one thousand dollars in the aggregate.

PUBLIC IMPROVEMENT CONTRACTS & DRUG-FREE WORKPLACE ACT:

If this is a solicitation for a public improvement construction contract, the vendor, by its signature below, affirms that it has a written plan for a drug-free workplace policy in compliance with Article 1D, Chapter 21 of the *West Virginia Code*. The vendor **must** make said affirmation with its bid submission. Further, public improvement construction contract may not be awarded to a vendor who does not have a written plan for a drug-free workplace policy in compliance with Article 1D, Chapter 21 of the *West Virginia Code* and who has not submitted that plan to the appropriate contracting authority in timely fashion. For a vendor who is a subcontractor, compliance with Section 5, Article 1D, Chapter 21 of the *West Virginia Code* may take place before their work on the public improvement is begun.

ANTITRUST:

In submitting a bid to any agency for the state of West Virginia, the bidder offers and agrees that if the bid is accepted the bidder will convey, sell, assign or transfer to the state of West Virginia all rights, title and interest in and to all causes of action it may now or hereafter acquire under the antitrust laws of the United States and the state of West Virginia for price fixing and/or unreasonable restraints of trade relating to the particular commodities or services purchased or acquired by the state of West Virginia. Such assignment shall be made and become effective at the time the purchasing agency tenders the initial payment to the bidder.

I certify that this bid is made without prior understanding, agreement, or connection with any corporation, firm, limited liability company, partnership or person or entity submitting a bid for the same materials, supplies, equipment or services and is in all respects fair and without collusion or fraud. I further certify that I am authorized to sign the certification on behalf of the bidder or this bid.

LICENSING:

Vendors must be licensed and in good standing in accordance with any and all state and local laws and requirements by any state or local agency of West Virginia, including, but not limited to, the West Virginia Secretary of State's Office, the West Virginia Tax Department, West Virginia Insurance Commission, or any other state agencies or political subdivision. Furthermore, the vendor must provide all necessary releases to obtain information to enable the Director or spending unit to verify that the vendor is licensed and in good standing with the above entities.

CONFIDENTIALITY:

The vendor agrees that he or she will not disclose to anyone, directly or indirectly, any such personally identifiable information or other confidential information gained from the agency, unless the individual who is the subject of the information consents to the disclosure in writing or the disclosure is made pursuant to the agency's policies, procedures and rules. Vendor further agrees to comply with the Confidentiality Policies and Information Security Accountability Requirements, set forth in <http://www.state.wv.us/admin/purchase/privacy/noticeConfidentiality.pdf>.

Under penalty of law for false swearing (*West Virginia Code* §61-5-3), it is hereby certified that the vendor affirms and acknowledges the information in this affidavit and is in compliance with the requirements as stated.

Vendor's Name: _____

Authorized Signature: _____ Date: _____