



State of West Virginia
 Department of Administration
 Purchasing Division
 2019 Washington Street East
 Post Office Box 50130
 Charleston, WV 25305-0130

Request for Quotation

RFQ NUMBER
RMA800002

PAGE
1

ADDRESS CORRESPONDENCE TO ATTENTION OF:
BUTCH CHITTUM 304-558-8806

RFQ COPY
 TYPE NAME/ADDRESS HERE

VENDOR

SHIP TO

WV STATE RAIL AUTHORITY
 (DBA) SOUTH BRANCH VALLEY
 RAILROAD
 120 WATER PLANT DRIVE
 MOOREFIELD, WV
 26836 304-538-2305

DATE PRINTED 07/25/2007	TERMS OF SALE	SHIP VIA	F.O.B.	FREIGHT TERMS
BID OPENING DATE: 08/21/2007		BID OPENING TIME 01:30PM		

LINE	QUANTITY	UOP	CAT NO.	ITEM NUMBER	UNIT PRICE	AMOUNT
				ADDENDUM #1		
				TO REPLACE THE ORIGINAL RFQ SPECIFICATIONS IN THEIR ENTIRETY WITH THE ATTACHED REVISED SPECIFICATIONS.		
				TIME OF COMPLETION HAS BEEN CHANGED FROM 120 DAYS FROM DATE OF NOTICE TO PROCEED TO "COMPLETION DATE FOR PROJECT IS JUNE 30, 2008.		
				BID OPENING DATE IS CHANGED FROM: 08/07/2007 TO: 08/21/2007		
				BID OPENING TIME REMAINS THE SAME @ 1:30 P.M.		
				NO OTHER CHANGES.		
0001	1	LS		055-57		
				INSTALLATION OF LED FLASHING LIGHTS		
***** THIS IS THE END OF RFQ RMA800002 ***** TOTAL:						

SEE REVERSE SIDE FOR TERMS AND CONDITIONS			
SIGNATURE	TELEPHONE	DATE	
TITLE	FEIN	ADDRESS CHANGES TO BE NOTED ABOVE	

WHEN RESPONDING TO RFQ, INSERT NAME AND ADDRESS IN SPACE ABOVE LABELED 'VENDOR'

**GENERAL TERMS & CONDITIONS
REQUEST FOR QUOTATION (RFQ) AND REQUEST FOR PROPOSAL (RFP)**

1. Awards will be made in the best interest of the State of West Virginia.
2. The State may accept or reject in part, or in whole, any bid.
3. All quotations are governed by the *West Virginia Code* and the *Legislative Rules* of the Purchasing Division.
4. Prior to any award, the apparent successful vendor must be properly registered with the Purchasing Division and have paid the required \$125.00 registration fee.
5. All services performed or goods delivered under State Purchase Orders/Contracts are to be continued for the term of the Purchase Order/Contract, contingent upon funds being appropriated by the Legislature or otherwise being made available. In the event funds are not appropriated or otherwise available for these services or goods, this Purchase Order/Contract becomes void and of no effect after June 30.
6. Payment may only be made after the delivery and acceptance of goods or services.
7. Interest may be paid for late payment in accordance with the *West Virginia Code*.
8. Vendor preference will be granted upon written request in accordance with the *West Virginia Code*.
9. The State of West Virginia is exempt from federal and state taxes and will not pay or reimburse such taxes.
10. The Director of Purchasing may cancel any Purchase Order/Contract upon 30 days written notice to the seller.
11. The laws of the State of West Virginia and the *Legislative Rules* of the Purchasing Division shall govern all rights and duties under the Contract, including without limitation the validity of this Purchase Order/Contract.
12. Any reference to automatic renewal is hereby deleted. The Contract may be renewed only upon mutual written agreement of the parties.
13. **BANKRUPTCY:** In the event the vendor/contractor files for bankruptcy protection, this contract is automatically null and void, and is terminated without further order.
14. **HIPAA Business Associate Addendum** - The West Virginia State Government HIPAA Business Associate Addendum (BAA), approved by the Attorney General, and available online at the Purchasing Division's web site (<http://www.state.wv.us/admin/purchase/vrc/hipaa.htm>) is hereby made part of the agreement. Provided that, the Agency meets the definition of a Covered Entity (45 CFR §160.103) and will be disclosing Protected Health Information (45 CFR §160.103) to the vendor.

INSTRUCTIONS TO BIDDERS

1. Use the quotation forms provided by the Purchasing Division.
2. **SPECIFICATIONS:** Items offered must be in compliance with the specifications. Any deviation from the specifications must be clearly indicated by the bidder. Alternates offered by the bidder as **EQUAL** to the specifications must be clearly defined. A bidder offering an alternate should attach complete specifications and literature to the bid. The Purchasing Division may waive minor deviations to specifications.
3. Complete all sections of the quotation form.
4. Unit prices shall prevail in cases of discrepancy.
5. All quotations are considered F.O.B. destination unless alternate shipping terms are clearly identified in the quotation.
6. **BID SUBMISSION:** All quotations must be delivered by the bidder to the office listed below prior to the date and time of the bid opening. Failure of the bidder to deliver the quotations on time will result in bid disqualifications.

SIGNED BID TO:

Department of Administration
Purchasing Division
2019 Washington Street East
Post Office Box 50130
Charleston, WV 25305-0130



Joe Manchin III
Governor

West Virginia Department of Transportation
State Rail Authority
120 Water Plant Drive, Moorefield, West Virginia 26836
304-538-2305 TDD 800-742-6991 Fax 304-538-7474
E-mail: jjphilbrick@dot.state.wv.us

To: All Attendees of the July 9, 2007 Prebid Meeting for the Installation of LED Flashers at Six Highway-Railroad Grade Crossings on the South Branch Valley Railroad

From: John Philbrick, Superintendent - WVSRA

Date: July 19, 2007

RE: Addendum to RFQ #RMA 800002 – Installation of LED Flashers on SBVR

This Addendum replaces the original RFQ specifications in its entirety.

Description of Work

The following six public highway-railroad grade crossings are to be upgraded with LED flashing lights, electronic bells, crossbuck signs and other items as indicated.

Green Spring Road, Hampshire County

Replace two 2-way light assemblies (two 4" masts)

U.S. Route 50, Vanderlip, Hampshire County

Replace two 2-way light assemblies (4" masts)

Replace one 1-way light assembly (4" mast)

Replace mechanical bell with electronic bell (4" mast)

Spring Avenue, Moorefield, Hardy County

Replace two 2-way light assemblies (4" masts)

Replace mechanical bell with electronic bell (4" mast)

Winchester Avenue, Moorefield, Hardy County

Replace three 2-way light assemblies

Replace one 1-way light assembly

Add one 2-way light assembly on jury arm to east cantilever mast

Relocate existing LED flashers onto jury mast on 4" mast

Replace mechanical bell with electronic bell (10" mast)

Replace crossbuck signs on cantilever masts and add one to each cantilever

Rewire both cantilever masts and add aluminum rodent shield to each mast (10")

Addendum to RMA 800002
Page 2 of 3

U.S. Route 220, Moorefield, Hardy County

- Replace three 2-way light assemblies (three 4" masts – includes jury arm on cantilever mast)
- Replace mechanical bell with electronic bell (10" mast)
- Replace two existing crossbuck signs and add crossbuck sign to cantilever.
- Rewire cantilever mast and add aluminum rodent shield (10")

Fisher Road, Moorefield, Hardy County

- Replace three 2-way light assemblies (one 12" mast, two 4" masts)
- Replace mechanical bell with electronic bell (4" mast)
- Replace crossbuck sign on cantilever mast and add one to cantilever.
- Add aluminum rodent shield to cantilever mast (12")

Conduct of Work

There will be a mandatory preconstruction meeting held prior to the commencement of work. This meeting will be attended by the contractor and the SRA/SBVR. The purpose of this meeting is to ensure that all parties involved have a common understanding of how the work will be performed.

The contact at the SBVR is John Philbrick at 304-538-2305, ext. 224.

The contractor shall comply with all safety rules and regulations as required by the Federal Railroad Administration, SBVR and other parties as applicable.

Contractor must aim and test all light units and bells after installation

The contractor is responsible for all traffic control and flagging during installation. This shall include flagging vehicular traffic for passing trains. If there will be any significant delays to vehicular traffic, the contractor must notify the SBVR and local emergency services.

The contractor shall be responsible for the repair of any damage done to the signal system at any crossing and shall make repairs in a timely fashion so as not to delay rail traffic.

The contractor shall use Heavy and Highway Construction Rates as established for Hampshire or Hardy County depending on the work location. These rates are pursuant to WV Code 21-5A, et., seq. and are available at www.wvsos.com/adlaw/wagerates/heavyhighway07.htm. The contractor shall be responsible for submitting certified payrolls to the State Rail Authority.

The completion date for this project is June 30, 2008.

Sign-in sheet from the prebid meeting is attached.

Addendum to RMA 800002
Page 3 of 3

Materials

The contractor will provide all materials required for this project. All materials must be new and meet or exceed FRA and AAR design criteria.

Light assemblies shall include the junction box, arms and lights. Light units must be new 12-inch LED type with new 20-inch vinyl or plastic backgrounds and new vinyl or plastic hoods. Light units must have side lights and have a clear front lens. Light output must be a minimum of 600 candelas. Light unit must remain lit if one or more LED's fail in service. Vendor must submit light unit type for SBVR approval prior to installation.

Crossbuck signs must be single-faced, diamond-grade reflective sheeting on face with black lettering, two-inch diamond grade stripe on back of sign running lengthwise in center of each blade.

Electronic bells must accurately reproduce the sound of a mechanical crossing bell. Information on the Safetran electronic bell is attached as an example. Volume of the electronic bell must be in the range of the Safetran "Loud-Tone" version.

All bolts will be stainless steel or anodized or be treated with an anti-seize compound.

A complete parts list and manufacturer contact numbers must be supplied upon completion of installation.

All light assemblies, crossbuck signs and bells removed as part of this project shall remain the property of the South Branch Valley Railroad. Any other materials removed shall be properly disposed of by the contractor. Nothing must be placed on adjacent property without the landowner's permission.

The state's tax exemption cannot be used on materials ordered by the contractor.

Bid Requirements

Bid must be a total amount that includes all costs associated with this project. The project will be awarded to the lowest qualified bidder. Contractor must have previous experience with highway-railroad grade crossing signal systems.

Electronic Crossing Bell

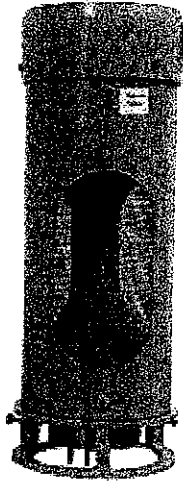

Safetran's Electronic Highway Crossing Bell is designed to accurately emulate the tone of conventional electro-mechanical crossing bells. The unit is available in both Soft and Loud-Tone versions and mounts atop 4 or 5-inch diameter signals masts without the need for additional hardware or mounting brackets.

Features

- Fully AREMA compliant
- Operates from 9 to 16 volts DC
- Soft-Tone version operates from 75 to 85 dB
- Loud-Tone version operates from 95 to 105 dB
- 250 strokes per minute (nominal)
- Permanently recorded tone
- Current draw of less than 150 mA
- Weighs less than 10 pounds
- No moving parts

Ordering Information

Loud-Tone	Part No.: 253165-T10906
Soft-Tone	Part No.: 253165-T09588

Bell Adapters

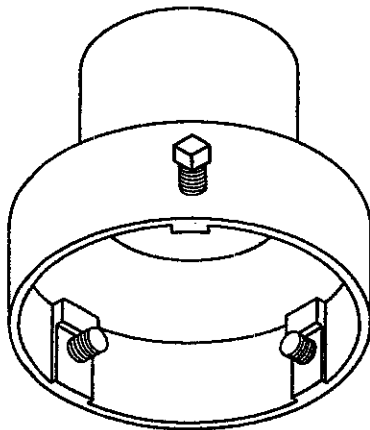

To order, specify bell adapter, mast size and part no.

Mast Size in Inches	Part Number
6"	040293-X
8"	035048-500X
10"	035063-X
12"	035062-X

Note: Safetran's Highway Crossing Bells are designed to fit directly on both 4- and 5-inch masts.

Pre-Bid Conference
SIGN IN SHEET

[Please Print]

Request for Proposal No.: RMA 800002 Date: 7/9/07
Installation of LED Flashing Lights on SBVR

Firm & Representative Name

Mailing Address

Telephone &
FAX Numbers

- | | | | |
|-----|---|--|--|
| 1. | <u>Railroad Signal Int.</u>
<u>Joachim Ortiz</u> | <u>6857 Hickory Ridge Ct.</u>
<u>Antioch, TN 37013</u> | T: <u>615-439-8521</u>
F: <u>918-234-1529</u> |
| 2. | <u>RAILWORKS</u>
<u>DAVID GUNKLE</u> | <u>6601 Southpoint Dr, N. Suite 160</u>
<u>JACKSONVILLE, FL 32216</u> | T: <u>904-296-5055</u>
F: <u>904-296-5056</u> |
| 3. | <u>Balfour BEATTY Rail Inc</u>
<u>Tom ZARO</u> | <u>216 NORTH RIVER St. Suite 310</u>
<u>Wilkes Barre, PA 18702</u> | T: <u>610 587-5267</u>
F: <u>570-822-2204</u> |
| 4. | <u>Scott Bahcock</u>
<u>DR Sig. Sucs.</u> | <u>PO Box 305</u>
<u>Grocery MD</u> | T: <u>410-442-1206</u>
F: <u>410-442-2971</u> |
| 5. | _____ | _____ | T: _____
F: _____ |
| 6. | _____ | _____ | T: _____
F: _____ |
| 7. | _____ | _____ | T: _____
F: _____ |
| 8. | _____ | _____ | T: _____
F: _____ |
| 9. | _____ | _____ | T: _____
F: _____ |
| 10. | _____ | _____ | T: _____
F: _____ |

Please print or write legibly. The fax number is essential to contact the attendees in a timely manner.

PURCHASING CONTINUATION SHEET

Buyer: BC-44	Page 7	Req. or P O No.: RMA800002
Spending Unit:		

Vendor:

Requisition No.: RMA800002

ADDENDUM ACKNOWLEDGEMENT

I hereby acknowledge receipt of the following checked addendum(s) and have made the necessary revisions to my proposal, plans and/or specifications, etc.

Addendum No.'s:

No. 1 _____

No. 2 _____

No. 3 _____

No. 4 _____

No. 5 _____

I understand that failure to confirm the receipt of the addendum(s) may be cause for rejection of bids.

Signature

Company

Date

STATE OF WEST VIRGINIA
Purchasing Division

PURCHASING AFFIDAVIT

West Virginia Code §5A-3-10a states: No contract or renewal of any contract may be awarded by the state or any of its political subdivisions to any vendor or prospective vendor when the vendor or prospective vendor or a related party to the vendor or prospective vendor is a debtor and the debt owned is an amount greater than one thousand dollars in the aggregate

DEFINITIONS:

"Debt" means any assessment, premium, penalty, fine, tax or other amount of money owed to the state or any of its political subdivisions because of a judgment, fine, permit violation, license assessment, defaulted workers' compensation premium, penalty or other assessment presently delinquent or due and required to be paid to the state or any of its political subdivisions, including any interest or additional penalties accrued thereon.

"Debtor" means any individual, corporation, partnership, association, limited liability company or any other form or business association owing a debt to the state or any of its political subdivisions. "Political subdivision" means any county commission; municipality; county board of education; any instrumentality established by a county or municipality; any separate corporation or instrumentality established by one or more counties or municipalities, as permitted by law; or any public body charged by law with the performance of a government function or whose jurisdiction is coextensive with one or more counties or municipalities. "Related party" means a party, whether an individual, corporation, partnership, association, limited liability company or any other form or business association or other entity whatsoever, related to any vendor by blood, marriage, ownership or contract through which the party has a relationship of ownership or other interest with the vendor so that the party will actually or by effect receive or control a portion of the benefit, profit or other consideration from performance of a vendor contract with the party receiving an amount that meets or exceed five percent of the total contract amount.

EXCEPTION: The prohibition of this section does not apply where a vendor has contested any tax administered pursuant to chapter eleven of this code, workers' compensation premium, permit fee or environmental fee or assessment and the matter has not become final or where the vendor has entered into a payment plan or agreement and the vendor is not in default of any of the provisions of such plan or agreement.

LICENSING: Vendors must be licensed and in good standing in accordance with any and all state and local laws and requirements by any state or local agency of West Virginia, including, but not limited to, the West Virginia Secretary of State's Office, the West Virginia Tax Department, West Virginia Insurance Commission, or any other state agencies or political subdivision. Furthermore, the vendor must provide all necessary releases to obtain information to enable the Director or spending unit to verify that the vendor is licensed and in good standing with the above entities.

CONFIDENTIALITY: The vendor agrees that he or she will not disclose to anyone, directly or indirectly, any such personally identifiable information or other confidential information gained from the agency, unless the individual who is the subject of the information consents to the disclosure in writing or the disclosure is made pursuant to the agency's policies, procedures and rules. Vendors should visit www.state.wv.us/admin/purchase/privacy for the Notice of Agency Confidentiality Policies.

Under penalty of law for false swearing (West Virginia Code, §61-5-3), it is hereby certified that the vendor acknowledges the information in this said affidavit and are in compliance with the requirements as stated.

Vendor's Name: _____

Authorized Signature: _____ Date: _____