



State of West Virginia
 Department of Administration
 Purchasing Division
 2019 Washington Street East
 Post Office Box 50130
 Charleston, WV 25305-0130

Request for Quotation

RFQ NUMBER
 GSD086428

PAGE
 1

ADDRESS CORRESPONDENCE TO ATTENTION OF
 KRISTA FERRELL
 304-558-2596

RFQ COPY
 TYPE NAME/ADDRESS HERE

VENDOR

SHIP TO

DEPARTMENT OF ADMINISTRATION
 GENERAL SERVICES DIVISION
 BUILDING 13 PARKING GARAGE
 GREENBRIER ST & PIEDMONT RD
 CHARLESTON, WV
 25301 304-558-2317

DATE PRINTED 06/04/2008	TERMS OF SALE	SHIP VIA	FOB	FREIGHT TERMS
BID OPENING DATE: 06/19/2008	BID OPENING TIME			01:30PM

LINE	QUANTITY	UOP	CAT NO	ITEM NUMBER	UNIT PRICE	AMOUNT
				ADDENDUM NO. 1		
				THIS ADDENDUM IS ISSUED TO:		
				1.) ANSWER ALL TECHNICAL QUESTIONS SUBMITTED DURING THE MANDATORY PRE-BID MEETING HELD ON MAY 27, 2008 AND THOSE QUESTIONS SUBMITTED PRIOR TO THE MAY 29, 2008 DEADLINE FOR TECHNICAL QUESTIONS.		
				2.) TO INCLUDE A COPY OF THE MANDATORY PRE-BID ATTENDEE LIST		
				3.) PROVIDE ADDITIONAL CLARIFICATIONS TO THE BID DOCUMENTS		
				4.) INCLUDE REVISED BID FORM, SECTION 01030 TO THE SPECIFICATIONS, DRAWINGS 2/A1, S-9R1, S-9R2, S-10R1, S-10R2, AND S-10R3.		
				AND		
				5.) EXTEND THE BID OPENING DATE		
				BID OPENING DATE IS EXTEND TO: 06/19/2008		
				BID OPENING TIME REMAINS: 1:30 PM		
				***** END ADDENDUM NO. 1 *****		
0001		JB		968-42		
	1			BLDG#13 PARKING GARAGE MODIFICATIONS		

SEE REVERSE SIDE FOR TERMS AND CONDITIONS

SIGNATURE	TELEPHONE	DATE
-----------	-----------	------

TITLE	FEIN	ADDRESS CHANGES TO BE NOTED ABOVE
-------	------	-----------------------------------

WHEN RESPONDING TO RFQ, INSERT NAME AND ADDRESS IN SPACE ABOVE LABELED 'VENDOR'

**GENERAL TERMS & CONDITIONS
REQUEST FOR QUOTATION (RFQ) AND REQUEST FOR PROPOSAL (RFP)**

1. Awards will be made in the best interest of the State of West Virginia.
2. The State may accept or reject in part, or in whole, any bid.
3. All quotations are governed by the *West Virginia Code* and the *Legislative Rules* of the Purchasing Division.
4. Prior to any award, the apparent successful vendor must be properly registered with the Purchasing Division and have paid the required \$125.00 registration fee.
5. All services performed or goods delivered under State Purchase Orders/Contracts are to be continued for the term of the Purchase Order/Contract, contingent upon funds being appropriated by the Legislature or otherwise being made available. In the event funds are not appropriated or otherwise available for these services or goods, this Purchase Order/Contract becomes void and of no effect after June 30.
6. Payment may only be made after the delivery and acceptance of goods or services.
7. Interest may be paid for late payment in accordance with the *West Virginia Code*.
8. Vendor preference will be granted upon written request in accordance with the *West Virginia Code*.
9. The State of West Virginia is exempt from federal and state taxes and will not pay or reimburse such taxes.
10. The Director of Purchasing may cancel any Purchase Order/Contract upon 30 days written notice to the seller.
11. The laws of the State of West Virginia and the *Legislative Rules* of the Purchasing Division shall govern all rights and duties under the Contract, including without limitation the validity of this Purchase Order/Contract.
12. Any reference to automatic renewal is hereby deleted. The Contract may be renewed only upon mutual written agreement of the parties.
13. **BANKRUPTCY:** In the event the vendor/contractor files for bankruptcy protection, this Contract may be deemed null and void, and terminated without further order.
14. **HIPAA Business Associate Addendum** - The West Virginia State Government HIPAA Business Associate Addendum (BAA), approved by the Attorney General, and available online at the Purchasing Division's web site (<http://www.state.wv.us/admin/purchase/vrc/hipaa.htm>) is hereby made part of the agreement. Provided that, the Agency meets the definition of a Covered Entity (45 CFR §160.103) and will be disclosing Protected Health Information (45 CFR §160.103) to the vendor.

INSTRUCTIONS TO BIDDERS

1. Use the quotation forms provided by the Purchasing Division.
2. **SPECIFICATIONS:** Items offered must be in compliance with the specifications. Any deviation from the specifications must be clearly indicated by the bidder. Alternates offered by the bidder as **EQUAL** to the specifications must be clearly defined. A bidder offering an alternate should attach complete specifications and literature to the bid. The Purchasing Division may waive minor deviations to specifications.
3. Complete all sections of the quotation form.
4. Unit prices shall prevail in cases of discrepancy.
5. All quotations are considered F.O.B. destination unless alternate shipping terms are clearly identified in the quotation.
6. **BID SUBMISSION:** All quotations must be delivered by the bidder to the office listed below prior to the date and time of the bid opening. Failure of the bidder to deliver the quotations on time will result in bid disqualifications.

SIGNED BID TO:

Department of Administration
Purchasing Division
2019 Washington Street East
Post Office Box 50130
Charleston, WV 25305-0130

ADDENDUM NO. 1

Date: June 2, 2008

To: ALL BIDDERS

From: BUCHART-HORN, INC.
 Consulting Engineers and Planners
 400 Tracy Way, Suite 110
 Charleston, WV 25311

Subject: Bid Documents

Project: Modifications to the West Virginia State Capitol Parking Facility
 PROJ. NO. WV GSD086428

NOTE: This Addendum forms a part of the Contract Documents and modifies the Original Documents dated **May 5, 2008 and Revised May 13, 2008**. Acknowledge receipt of this Addendum in the space provided on the Bid Form. Failure to do so may subject the Bidder to disqualification.

PRE-BID CONFERENCE

A mandatory pre-bid conference was held at the project site on May 26, 2008 at 10:00am. A copy of the attendees list is attached to this Addendum.

ANSWERS TO BIDDER'S QUESTIONS

Per the Request for Proposal all questions and requests for substitutions were required to be submitted to Krista Ferrell prior to the deadline of the close of business on 5/29/08. No requests for substitutions were received. Attached are the questions received and the responses thereto.

ITEM A - REVISIONS TO THE BIDDING DOCUMENTS

Section 00331, Bid Form - DELETE Section 00331, Bid Form in its entirety and REPLACE with revised bid form attached to this Addendum No. 1. *The revised bid form modified the work included under UNIT PRICE Items.*

ITEM B - REVISIONS TO THE BIDDING REQUIREMENTS IN THE PROJECT MANUAL

Section 00331, Bid Form - DELETE Section 00331, Bid Form in its entirety and REPLACE with revised bid form attached to this Addendum No. 1. *The revised bid form modified the work included under UNIT PRICE Items.*

Section 01030, Alternates, Unit Prices and Allowances- DELETE Section 01030, Alternates, Unit Prices and Allowances in its entirety and REPLACE with revised Section 01030 attached to this Addendum No. 1. *The revised bid form modified the work included under UNIT PRICE Items.*

ITEM C - REVISIONS TO THE CONTRACT FORMS IN THE PROJECT MANUAL

None at this time

ITEM D - REVISIONS TO THE CONDITIONS OF THE CONTRACT IN THE PROJECT MANUAL

None at this time

ITEM E - REVISIONS TO THE SPECIFICATIONS IN THE PROJECT MANUAL

None at this time

ITEM F - REVISIONS TO THE DRAWINGS

Drawing A-1

ADD THE ATTACHED DRAWING 2/A-1

Drawing A-4, Sheet No. 5; Drawing A-5, Sheet No. 6; Drawing A-6, Sheet No. 7; . Drawing No. A-10, Sheet No. 11; Drawing No. A-11, Sheet No. 12; Drawing No. A-12, Sheet No. 13; Drawing A-13, Sheet No. 14

AT THE END OF KEYNOTE #8 ADD THE FOLLOWING:

"FOR QUANTITIES AND LOCATIONS OF SLEEVES REFER TO SHEETS A10, A11, A12 AND A13 ONLY"

Drawing No. A-10, Sheet No. 11; Drawing No. A-11, Sheet No. 12; Drawing No. A-12, Sheet No. 13; Drawing No. A-13, Sheet No. 14

DELETE KEYNOTE #6

Drawing No. S-1, Sheet No. 17, Typical Precast Notes and Details

At TYPICAL REPAIR NOTE I, DECK COATING SYSTEM

CHANGE Note 1. to read: "AFTER PREPARATION, AT ALL DECK AREAS TO RECEIVE DECK COATING (SEE PLANS) , **PROVIDE SHOT-BLAST CLEANING THEN** APPLY EPOXY BROADCAST SYTEM PER SPECS.... (The rest of the note will remain unchanged)

At TYPICAL REPAIR NOTE J, CLEAR WATERPROOF COATING

CHANGE Note 1. to read: "(UNDER ALTERNATE-SEE PLANS FOR LOCATIONS) **PROVIDE SHOT-BLAST CLEANING THEN** APPLY CLEAR WATERPROOFING MATERIAL... (The rest of the note will remain unchanged)

Drawing No. S-9, Sheet No. 25, Tee Flange Weld Details

CHANGE BASE REPAIR DETAILS 1/S-9 and 2/S-9 as indicated on attached supplemental drawings S-9R1 and S-9R2.

Drawing No. S-10, Sheet No. 26, Structural Details

ADD TYPICAL REPAIR AT SLAB WELD POCKET DETAILS as indicated on attached supplemental drawings S-10R1 and S-10R2

CHANGE TYPICAL SLAB JOINT SEALANT AND SLAB COATING DETAIL as indicated on attached supplemental drawings S-10R3.

END OF ADDENDUM NO. 1

MODIFICATIONS TO THE WEST VIRGINIA STATE CAPITOL
 PARKING FACILITY
 BH# 76470-00

Mandatory Pre-Bid Meeting: Tuesday, May 27, 2008 10:00 am
 Meet at the first floor of the parking garage

Name	Company	Address	Phone	Fax
Bill Kostelic	Concrete Reservations	406 PENN GREEN #306 Rt. Pa 15235	412-824-2800	412-824-0628
Bill Yarewell	Allegheny Restoration Inc	723 Linwood Drive Greensburg Pa 15601	724-832-8218	724-832-8209
Colin Randolph	SKA Corp.	156 Parkwell Ave. Pittsburgh, PA 15237	412-337-1103	412-366-7407
Don Simmons	BBB Carter	900 West Charleston W.V.	304-325-1905	304-325-1304
Ken Starcher	BBE Carlton	900 West St. Charleston W.V.	(304) 345-1300	345-1304
Scott Masau	GSD		558-1808	
Bert Corcoran	GSD		558-1808	
Ted Foyne	Wiseman Const Co	1616 6th Ave Charleston	344-1200	412
Joe White	Camuelto Const	935 Vista Park Dr. Rte. To 15205	490-2924	490-2528
Mike Phillips	Buchart Horn	Suite 110, 400 Tracy Way, CHAS	304-346-1127	304-346-7295
Luke Cunningham	Buchart Horn	Suite 110, 400 Tracy Way, CHAS	304-346-1127	304-346-7295

**Modifications to the
West Virginia State Capitol Parking Facility
GSD 086428
CONTRACTOR QUESTIONS (NUMBERED)
A/E RESPONSES (BOLD WITH A/E)
6/2/08**

1. Keynotes 1, 2, 3, 9 & 10 on A-10 refer to replacing sealants at various locations. However, they are not called out anywhere on this drawing. Is there any slab sealant replacement on the Ground Level, and if so, is it included in the 16,000 LF of re-sealing of slab joints?

A/E: There are no slab joints to receive sealant on Sheet A-10 which is the ground floor or "level 1".

2. There is no reference to replacing the pour strip sealants on the architectural drawings but there are notes on drawing S-10 referring to pour strip sealants. Please confirm that they do get replaced and that they are also included in the 16,000 LF of re-sealing of slab joints.

A/E: On Plans for Sheets A11, A12 and A13 note 2 appears slightly left of column line #4 and states "TYPICAL ALL TEES". Therefore all pour strip sealant shall be replaced and is included in the 16,000 lf bid quantity.

3. What exactly is Keynote 6 on drawings A-10 through A-13 referring to? I thought it might be painting elevator/stair doors & frames, but the locations and quantities are not the same as shown on drawings as Keynotes 4 & 5 on A-4 through A-7.

A/E: Delete keynote #6 from Sheets A10, A11, A12 and A13 - SEE ADDENDUM

4. The number of sleeves shown to be painted per Keynote 8 on drawings A-4 through A-7 is in conflict with the number of sleeves shown to be painted per Keynote 8 on drawings A-10 through A-13. Please comment.

A/E: Refer to Sheets A10, A11, A12 and A13 for quantities and locations of sleeves to be prepared and painted and sealed per Keynote #8 on Sheet A4, A5, A6 and A7; and Keynote #8 on Sheet A10, A11, A12 and A13. - SEE ADDENDUM

5. Please clarify "penetrating sealer" in Note 2. on drawing S-7. The epoxy overlay/floor coating system cannot be applied over a penetrating sealer as per Specification Section 07180. Is it referring to the penetrating, corrosion inhibiting, steel reinforcement coating per Specification Section 03731?

A/E: On Sheets S3, S5 and S7 at Plan Note #2; Change notation from "penetrating sealer" to "penetrating corrosion inhibitor per spec section 03731".- SEE ADDENDUM

6. How will the assigned contractor/weld inspector performing the weld connection repair be coordinated with the restoration work so as not to impede on the phasing/completion of the restoration work within the allotted 180 days?

A/E: The contractor has coordination responsibility; including coordination with the owner and with other contractors assigned by the owner. Article 1.5 of Specifications Section 01010 requires the successful contractor to submit a schedule. This schedule will be reviewed by the owner and their agents for input to reduce scheduling conflicts. As with all work on the project, any claims for delay due to circumstances beyond the contractor's control will be reviewed on a case by case basis.

BID FORM
General Construction

Pursuant to and in compliance with your Advertisement for Bids and the Information for Bidders relating thereto, the undersigned hereby offers to furnish all plans, labor, materials, supplies, equipment and other facilities necessary for, or proper for, or incidental to the **Construction of the MODIFICATIONS TO THE WV STATE CAPITOL GARAGE #GSD086428** as required by, and in strict accordance with the applicable provisions of plans and project manual and all addenda issued by the **STATE OF WEST VIRGINIA, GENERAL SERVICES DIVISION** or its Architect prior to the date of opening the bids whether received by the undersigned or not for the amount bid based on the following unit and/or lump sum prices.

NOTE: Extension of Unit Prices **must** be exact.

Contract time: 180 Calendar Days

Schedule of Liquidated Damages:

One (1) to Fifteen (15) Days: \$500 per calendar day
Sixteen (16) to Thirty (30) days: \$1000 per calendar day

The Owner reserves the right to award a contract or contracts for the work described in the plans and specifications in any combination of the following Base Bid, Alternates and Unit Prices.

In submitting this Bid, BIDDER represents, as more fully set forth in the Agreement, that:

- (a) BIDDER has examined copies of all the Contract Documents and hereby acknowledges receipt of the following Addenda:

<u>Number</u>	<u>Date</u>
_____	_____
_____	_____
_____	_____

- (b) This Bid is genuine and not made in the interest of or on behalf of any undisclosed person, firm or corporation and is not submitted in conformity with any agreement or rules of any group, association, organization or corporation; BIDDER has not directly or indirectly induced or solicited any other Bidder to submit a false or sham Bid; BIDDER has not solicited or induced any person, firm or a corporation to refrain from bidding; and BIDDER has not sought by collusion to obtain for himself any advantage over any other Bidder or over OWNER; and
- (c) BIDDER hereby states that he has available adequate equipment and finances to properly and expeditiously prosecute the Work as bid, and is prepared to present further information to substantiate this statement.

03. ALLOWANCES - Refer to Section 01030 Alternates, Unit Prices and Allowances for Descriptions.

<u>ITEM</u>	<u>DESCRIPTION</u>	<u>ESTIMATED QUANTITIES</u>	<u>UNIT PRICE</u>	<u>EXTENDED</u>
03.1	Reinforcing Bars to replace existing reinforcing bars found to be damaged beyond repair.	1,200 LB	@ \$ _____ /LB = \$ _____	
03.2	Additional Electrical Circuits (assume add one 1P-20A breaker, 100 ft 2-#12 THHN,#12 GND in 3/4" GRC, hangers, supports and load terminations)	4 EA	@ \$ _____ /EA = \$ _____	
03.3	Additional Electrical Conduit Replacement (assume type D repair as shown in drawings)	300 LF	@ \$ _____ /LF = \$ _____	
TOTAL OF ALLOWANCE ITEMS				\$ _____
TOTAL BASE BID FOR GENERAL CONTRACT (Sum of Item 01 Lump Sum, 02 Unit Price Bid Items, and 03 Allowance Items)				\$ _____

(Figures)

In Words _____

ALTERNATE BID ITEMS

The stated base Bid is subject to the following addition or deduction for Alternate.
(Refer to Division 1 for additional descriptions)

Alternate 1:	ADD Re-stripping 1st, 2nd and 3rd levels, including ramps.	ADD	\$ _____
Alternate 2:	ADD Penetrating Corrosion Inhibiter and Clear waterproof sealer to 2nd and 3rd levels, including ramps.	ADD	\$ _____
Alternate 3:	New Vestibules for Elevator and Doors on 4 th Level.	ADD	\$ _____
Alternate 4:	New area drain and piping.	ADD	\$ _____

ESTIMATED QUANTITIES

It is understood that the estimated quantities of the various Unit Price Items listed in the Bid Form are only approximate and are so listed only as a basis upon which the OWNER may evaluate Bids, and the undersigned BIDDER further agrees that if the final quantities of the Unit Price Items tabulated above are greater or less than the estimated quantities, he will accept these additions to, or deductions from the Total Base Bid as awarded, basing these additions or deductions upon the unit prices shown previously in the Bid Schedule. These additions or deductions will be accepted by the Bidder regardless of the amount of the variations from the estimated quantities, which as stated above, are only approximate and are only for the use of the OWNER. These unit prices include all other materials, equipment, tools, labor, and all other work incidental to construction.

76470-00

MODIFICATIONS TO THE
WV CAPITOL PARKING FACILITY

AN INDIVIDUAL

SUBMITTED this _____ day of _____, 20__.

By: _____
(Typed/Printed Name) (Signature)

Doing Business As:

Business Address: _____ (SEAL)

Phone No.: (____) _____ FAX No.: (____)

A PARTNERSHIP

SUBMITTED this _____ day of _____, 20__.

Firm Name:

By: _____ Partner (Typed/Printed Name) Partner (Signature)

By: _____ Partner (Typed/Printed Name) Partner (Signature)

Business Address: _____ (SEAL)

Phone No.: (____) _____ FAX No.: (____)

A CORPORATION

SUBMITTED this _____ day of _____, 20__.

Corporation Name:

State of Incorporation:

By: _____ (Person Authorized to Sign) (Signature) Title
(Typed/Printed Name)

Attest: _____ Corporate Secretary
(Typed/Printed Name) (Signature)

Business Address: _____ (CORPORATE SEAL)

Phone No.: (____) _____ FAX No.: (____)

**SECTION 01030
ALTERNATES, UNIT PRICES AND ALLOWANCES****PART 1 - GENERAL****1.1 ALTERNATES**

1. This Section specifies administrative and procedural requirements for Alternates.
2. An Alternate is an amount proposed by Bidders and stated on the Form of Proposal or Bid Form for certain construction activities defined in the Bidding Requirements that may be added to or deducted from Base Bid amount if the Owner decides to accept a corresponding change in either the amount of construction to be completed, or in the products, materials, equipment, systems or installation methods described in Contract Documents.
3. Coordination: Coordinate related Work and modify or adjust adjacent Work as necessary to ensure that Work affected by each accepted Alternate is complete and fully integrated into the Project.
4. Notification: Immediately following the award of the Contract, prepare and distribute to each party involved notification of the status of each Alternate. Indicate whether Alternates have been accepted or rejected. Include a complete description of negotiated modifications to Alternates.
5. Schedule: A "List of Alternates" is included at the end of this Section. Specification Sections may reference this Section to describe the Work under each Alternate.
6. Include, as part of each Alternate, miscellaneous devices, accessory objects and similar items incidental to or required for a complete installation whether or not mentioned as part of the Alternate.
7. Include as part of the Base Bid, Optional Bids, and Alternate Bids, the allowance items as herein specified. All allowance items shall be included in conformance with the General Conditions of the Contract for Construction.

1.2 UNIT PRICES

1. Definition: A Unit Price is an amount proposed by Bidders and stated on the Form of Proposal for certain construction activities when the amount of work varies from the amount stated for inclusion in the Base Bid. The amount stated on the Form of Proposal shall be used as the basis to start the change order process.

2. List of Unit Prices to be included in Base Bid is stated at the end of this Section. For Unit Prices where a quantity is not stated, the Bidder shall not include any work in the Base Bid for this Unit Price.
3. For combined Contract, the sum of the quantities stated for each Contract shall be included in the Base Bid.

1.3 ALLOWANCES

1. Allowances are for additional unforeseen work or costs that may or may not ultimately be required. Allowances shall be included in Base Bid and contract value. For each reduction in the allowance an "Allowance Reduction" form will be issued showing the remaining balance. All parties will sign the reduction form (similar to a change order). After project completion, any unused allowance will be credited back to the Owner via a deduct change order, reducing the overall contract value accordingly.
2. Contractor is not entitled to markup on unused allowance for any allowances herein specified.

PART 2 - PRODUCTS (Not Applicable)

PART 3 - EXECUTION

3.1 LIST OF ALTERNATES

ALTERNATE #1

Additive Alternate to supply all materials and provide all work associated with preparing and re-striping the 1st, 2nd and 3rd levels, including ramps. None of this work shall be included in the Base Bid. Re-striping of the ramp from 3rd level to 4th level, and re-striping of the 4th level shall be included in the Base Bid.

ALTERNATE #2

Additive Alternate to supply all materials and provide all work associated with preparing and installing penetrating corrosion inhibitor and clear waterproof sealer to 2nd and 3rd levels, including ramp from ground level to 2nd level and 2nd level to 3rd level. None of this work shall be included in the Base Bid.

ALTERNATE #3

Additive Alternate to supply all materials and provide all work associated with preparing and installing new vestibules on the 4th level. None of this work shall be included in the Base Bid.

ALTERNATE #4

Additive Alternate to supply all materials and provide all work associated with preparing and installing a new 24" x 24" precast drop inlet per drawing 2/A-1 in this addendum. Work includes 126' of 8" traffic rated corrugated metal piping to attach new inlet to existing drop inlet per details on 2/A-1. Trench new line thru existing asphalt paving area and patch paving as per details. Assumes maximum trench depth of 36".

3.2 LIST OF UNIT PRICES**UNIT PRICE #1**

Unit price to supply all materials and provide all work associated with preparing and patching of Spalled Concrete at Vertical and Horizontal (non-Overhead) Surfaces; per square foot assuming a bid depth of 3 inches. Includes concrete removal, surface preparation, cleaning and coating of reinforcement, application of bonding agent and placement of patching material; complete in place.

UNIT PRICE #2

Unit price to supply all materials and provide all work associated with preparing and patching of Spalled Concrete at Horizontal Overhead Surfaces; per square foot assuming a bid depth of 3 inches. Includes concrete removal, surface preparation, cleaning and coating of reinforcement, application of bonding agent and placement of patching material; complete in place.

UNIT PRICE #3

Unit price to supply all materials and provide all work associated with preparing and making Structural Crack Repairs at Vertical, Horizontal and Overhead Surfaces, per linear foot; complete and in-place.

UNIT PRICE #4

Unit price to supply all materials and provide all work associated with preparing and Re-Sealing of Slab Joints; per linear foot, including removal of existing material, surface preparation, and placement of new materials, complete and in-place.

UNIT PRICE #5

Unit price to supply all materials and provide all work associated with preparing and Re-Sealing of Wall Panel Joints and Column Joints; per linear foot, including removal of existing material, surface preparation, and placement of new materials, complete and in-place.

UNIT PRICE #6

Unit price to supply all materials and provide all work associated with preparing and installing Carbon Fiber wrap at existing double Precast Double Tees; *per square foot of concrete surface to be wrapped.*

UNIT PRICE #7

Unit price to supply all materials and provide all work associated with Replacing Plastic Connection Covers; per each. Work noted on the plans shall be included in the Base Bid, the Unit price shall be for increase or decrease of said work.

UNIT PRICE #8

Unit price to supply all materials and provide all work associated with preparing and Re-welding steel connections within the existing precast concrete structure, (excluding Slab-to-slab joint connections); per inch. Includes all inspection as specified.

UNIT PRICE #9

Unit price to supply all materials and provide all work associated with preparing and placing cementitious horizontal overlay as indicated on drawings; per square foot, assuming a bid depth of 2 inches. Includes removal of existing material, surface preparation, and placement of new materials, complete and in-place.

UNIT PRICE #10

Unit price to supply all materials and provide all work associated with preparing and sealing all Non-Structural Cracks at Horizontal Surfaces, per linear foot; complete and in-place.

UNIT PRICE #11

Unit price to supply all materials and provide all work associated with chipping out cracked or spalled concrete at existing slab weld pockets to a 1/2" depth x 4" x 12" area then preparing and sealing the area with sealant, per each location, complete and in-place. Locations to be determined and mutually agreed upon by contractor, architect and owner prior to construction.

UNIT PRICE #12

Unit price to supply all materials and provide all work associated with chipping out cracked or spalled concrete at existing slab weld pockets to a 3/4" depth x 8" x 12" area then preparing and patching the area with a sand / epoxy mix, per each location, complete and in-place. Locations to be determined and mutually agreed upon by contractor, architect, and owner prior to construction.

3.3 LIST OF ALLOWANCES

ALLOWANCE #1

Unit price to supply all materials and provide all work associated with removal and replacement of existing steel reinforcing bars found to be damaged beyond repair; per pound of new reinforcing bars. Work includes removal, replacement, splice connections, preparation and coating; complete in-place.

ALLOWANCE #2

Unit price to supply all materials and provide all work associated with preparing and installing *Additional* electrical circuits, per each circuit as described on the bid form.

ALLOWANCE #3

Unit price to supply all materials and provide all work associated with preparing and installing *Additional* electrical conduit replacement; per linear foot.

END OF SECTION

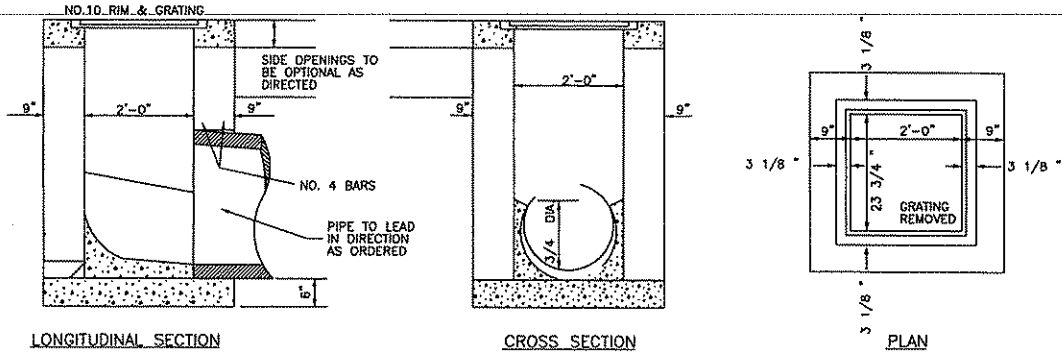

NOTE: CONC TO BE CLASS 'A'

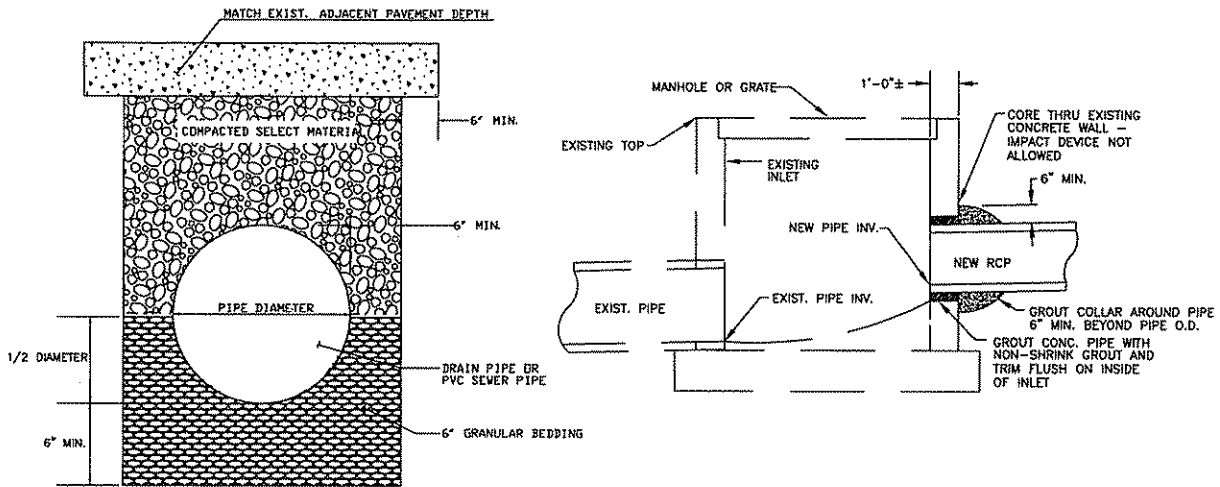

GENERAL NOTES

1. WORK MUST FULLY ADHERE TO WVDOT SPECIFICATIONS AND IN NO WAY SHALL INTERFERE WITH THE OPERATION OF THE OWNER'S FACILITY.
2. VERIFY ALL UNDERGROUND UTILITIES WITH MISS UTILITY, OWNER AND UTILITY PROVIDER PRIOR TO START OF WORK.
3. CONTRACTOR SHALL CAREFULLY REMOVE PAVEMENT AS NECESSARY TO MAKE IMPROVEMENTS - CONTRACTOR SHALL PROCEED WITH CAUTION SO AS TO NOT DISTURB EXISTING ADJACENT STRUCTURES OR UTILITIES.

PROJECT NO.:	78470-00
ENGR./ARCH.:	MMP
DRAWN BY:	LRC
DESIGN BY:	MMP
CHECKED BY:	MMP
CAD FILE:	X
DATE:	JUNE 2, 2008



**MODIFICATIONS TO THE
STATE CAPITOL PARKING FACILITY**
WV DEPARTMENT OF ADMINISTRATION
GENERAL SERVICES DIVISION
CHARLESTON, WEST VIRGINIA

2/A-1
DRAWING NO.

SHEET OF

REMOVE ALL EXISTING SEALANT AND BACKER (UNDER CONTRACT)

PRECAST TEE FLANGE

EXISTING EMBEDDED PLATES TO REMAIN

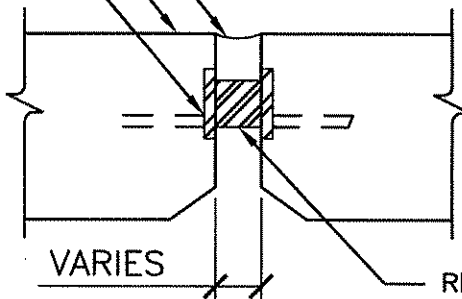

REMOVE ALL EXISTING STEEL WELD SLUGS * (N.I.C.)

1 (S-9R1) (REVISED) - TYPICAL TEE FLANGE - REMOVAL DETAIL

NOTES:

- 1.) EXCEPT FOR SEALANT REMOVAL. ALL WORK IS NOT-IN-CONTRACT (N.I.C.) TO BE PERFORMED BY A CONTRACTOR ASSIGNED BY THE OWNER.
- 2.) WHERE * IS INDICATED - ASSIGNED CONTRACTOR PERFORMING THIS WORK MAY ALTERNATIVELY PROVIDE WELD TESTING REPORTS FROM AN INDEPENDENT AGENCY TO SHOW WHICH EXISTING WELD SLUGS ARE ADEQUATELY WELDED WITH NO DEFECTS AND THUS MAY REMAIN IN PLACE. OTHERWISE REPLACE ALL WELD SLUGS AT ALL TEE-FLANGE CONNECTIONS.

3.) SEE TYPICAL DETAILS ON SUPPLEMENTAL DRAWING S-10R1 AND S-10R2 FOR PREPARATION AND REPAIRS AT WELD POCKETS.

REVISED DETAIL - ADDENDUM NO. 1

PROJECT NO.: 76470-00
ENGR./ARCH.: JMC
DRAWN BY: MPL
DESIGN BY: JMC
CHECKED BY: JMC
CAD FILE: X
DATE: 05/30/2008



MODIFICATION TO THE
 STATE CAPITOL PARKING FACILITY
 WV DEPARTMENT OF ADMINISTRATION
 GENERAL SERVICES DIVISION
 CHARLESTON, WEST VIRGINIA

S-9R1
DRAWING NO.
SHEET 1 OF 1

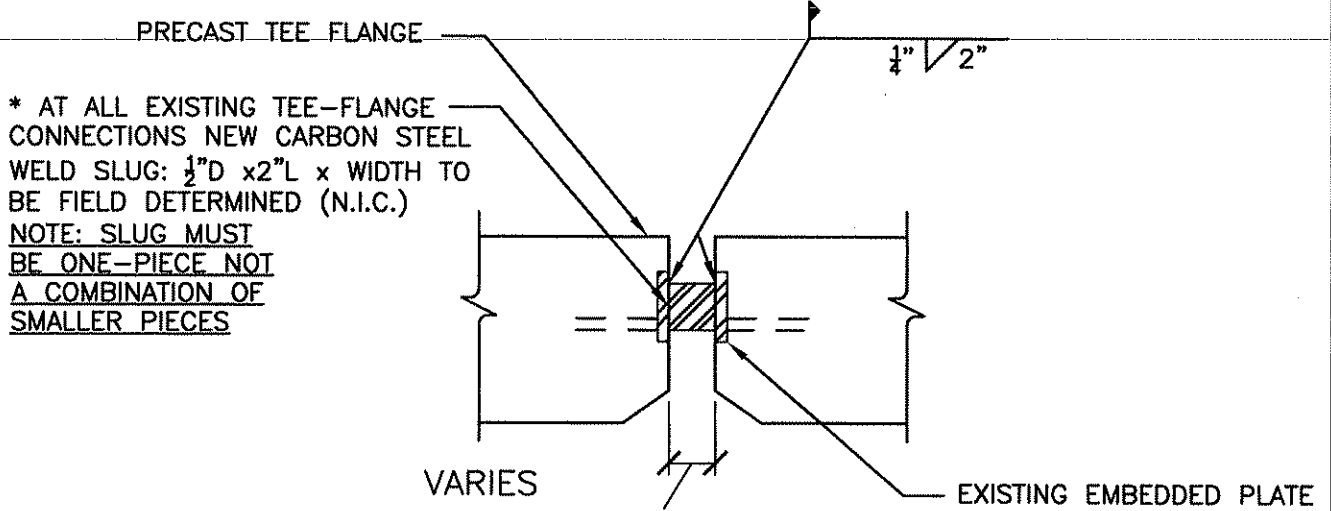

2 (REVISED) - TYPICAL TEE FLANGE -
 S-9R2 WELD SLUG REPLACEMENT

NOTES:

- 1.) ALL WORK IS NOT-IN-CONTRACT UNLESS NOTED OTHERWISE. TO BE PERFORMED BY A CONTRACTOR ASSIGNED BY THE OWNER.
- 2.) WHERE * IS INDICATED, SEE NOTE AT TYPICAL TEE FLANGE REMOVAL DETAIL.
- 3.) ASSIGNED CONTRACTOR PERFORMING THIS WORK SHALL HAVE AN INDEPENDENT TESTING AGENCY PERFORM WELD TESTING ON 33% OF THE NEW WELDS AND SHALL SUBMIT REPORTS TO THE OWNER AND ENGINEER. ALL DEFECTIVE WELDS SHALL BE REMOVED AND REINSTALLED. OWNER RESERVES THE RIGHT TO ORDER ADDITIONAL INSPECTION OR INSTALLATION OF ALTERNATIVE DETAIL AS SHOWN ON THIS SHEET IF A HIGH OCCURRENCE OF DEFECTS IS REVEALED, AT NO COST TO THE OWNER.
- 4.) AFTER WELD INSPECTION, COAT ALL LUGS WITH EPOXY COATING AT TOP, UNDERSIDE, AND ENDS (NOT-IN-CONTRACT) BY OWNER-ASSIGNED CONTRACTOR.

5.) NOTE 5 DELETED

REVISED DETAIL -
 ADDENDUM NO. 1

PROJECT NO.: 76470-00
ENGR./ARCH.: JMC
DRAWN BY: MPL
DESIGN BY: JMC
CHECKED BY: JMC
CAD FILE: X
DATE: 05/30/2008



MODIFICATION TO THE
 STATE CAPITOL PARKING FACILITY
 WV DEPARTMENT OF ADMINISTRATION
 GENERAL SERVICES DIVISION
 CHARLESTON, WEST VIRGINIA

S-9R2
DRAWING NO.
SHEET 1 OF 1

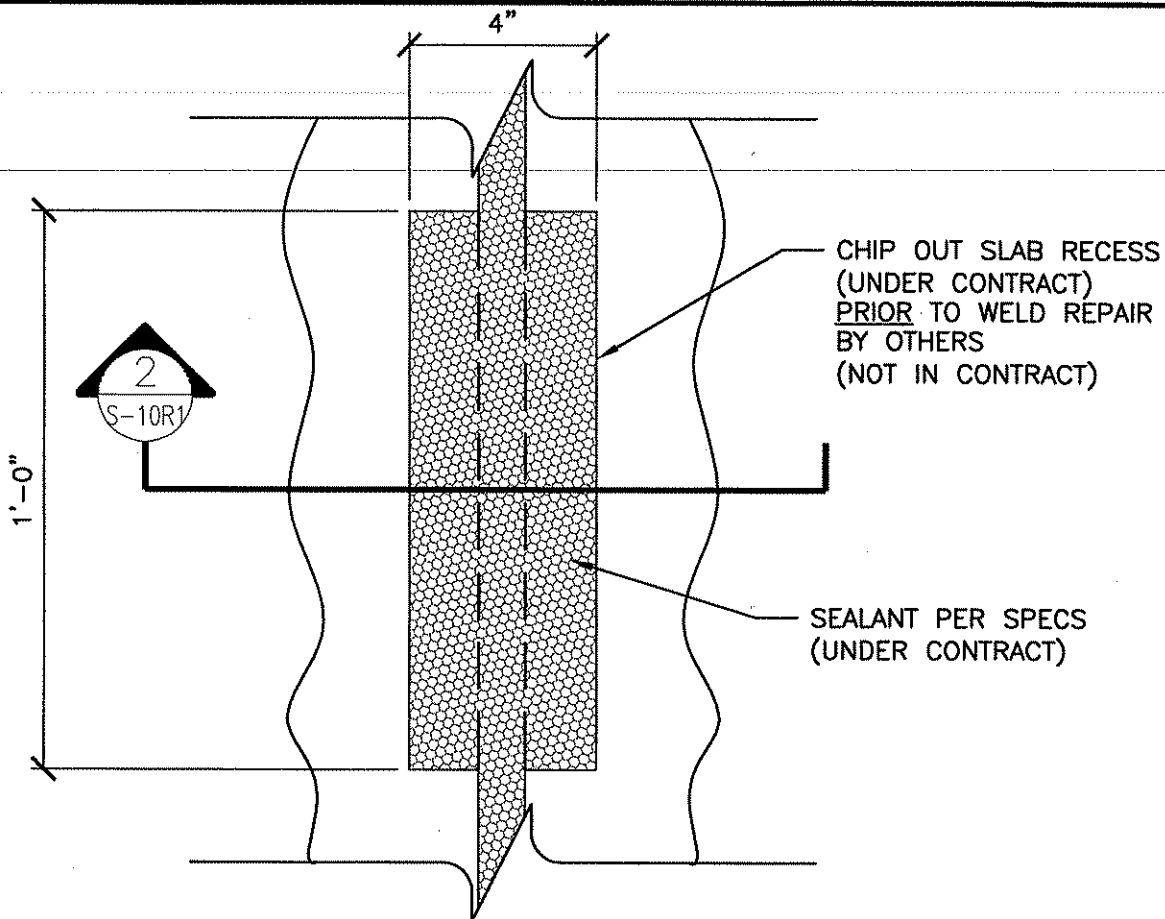

CHIP OUT SLAB RECESS
(UNDER CONTRACT)
PRIOR TO WELD REPAIR
BY OTHERS
(NOT IN CONTRACT)

SEALANT PER SPECS
(UNDER CONTRACT)

PLAN VIEW

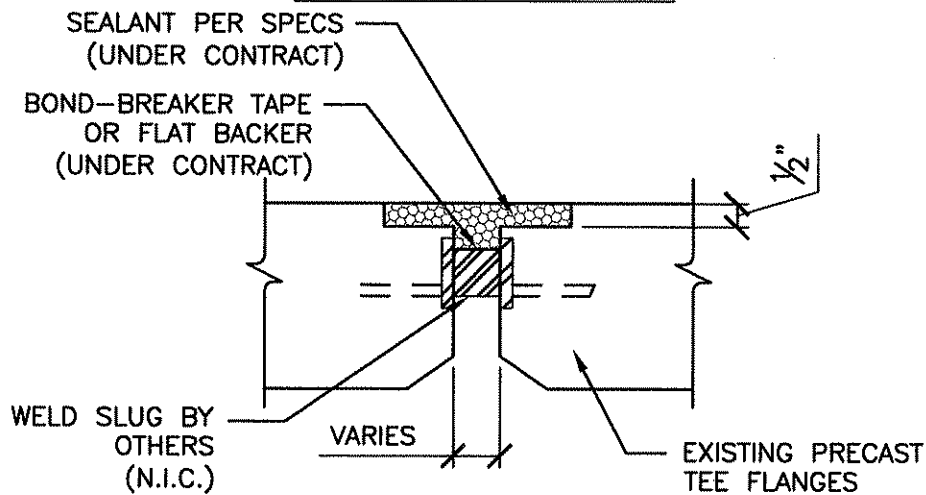

SECTION
S-10R1

TYPICAL REPAIR AT SLAB

WELD POCKETS

CASE 1: "MINOR" REPAIR, BID
QTY=2,000 LOCATIONS

ADDED DETAILS -
ADDENDUM NO. 1

PROJECT NO.: 76470-00
ENGR./ARCH.: JMC
DRAWN BY: MPL
DESIGN BY: JMC
CHECKED BY: JMC
CAD FILE: X
DATE: 05/30/2008



MODIFICATION TO THE
STATE CAPITOL PARKING FACILITY
WV DEPARTMENT OF ADMINISTRATION
GENERAL SERVICES DIVISION
CHARLESTON, WEST VIRGINIA

S-10R1
DRAWING NO.
SHEET 1 OF 1

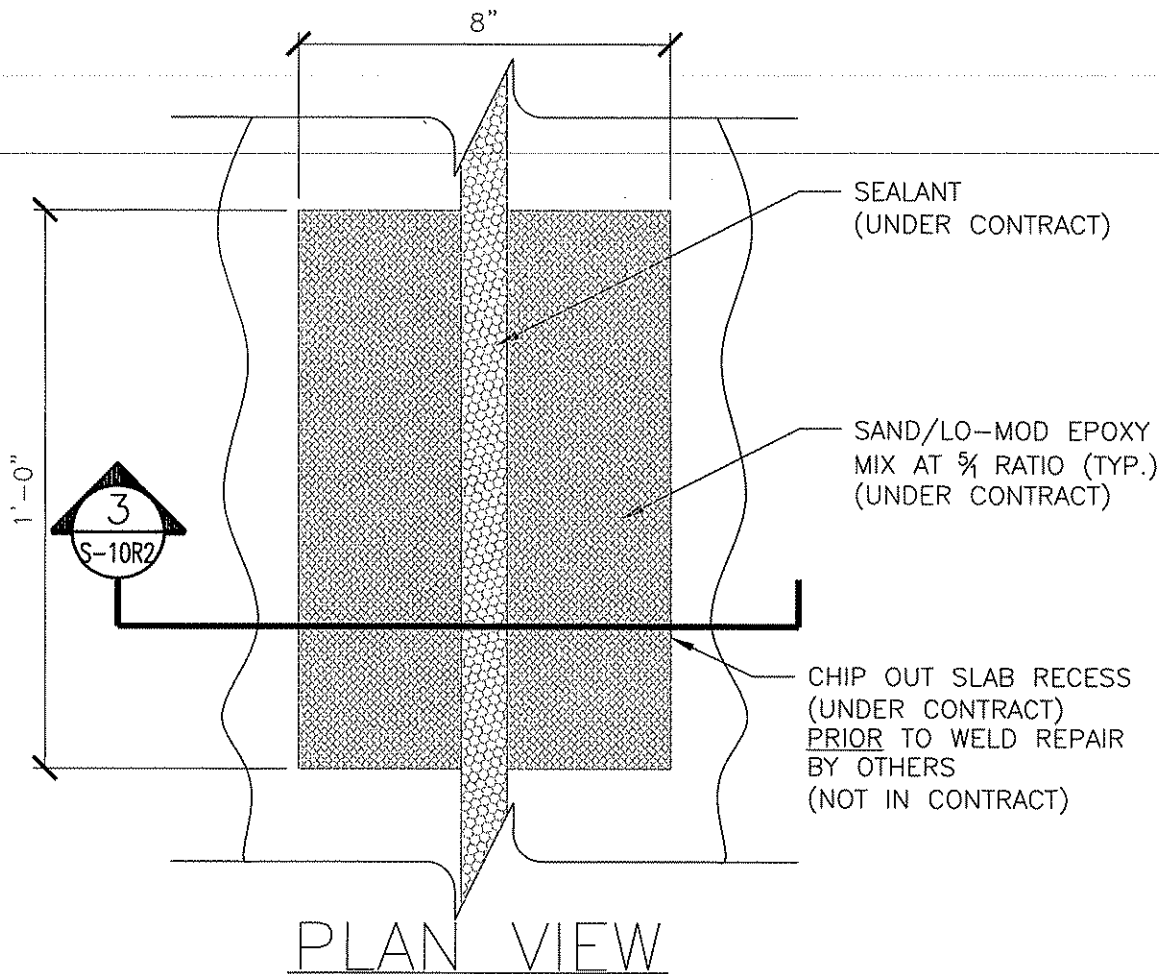

PLAN VIEW

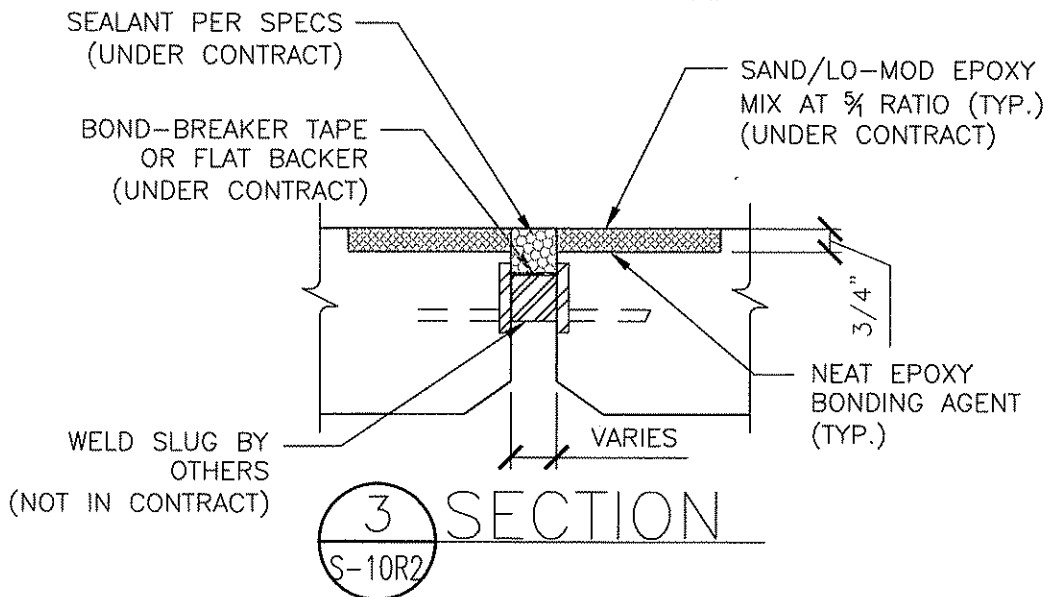

SECTION

TYPICAL REPAIR AT SLAB

WELD POCKETS CASE 2: "MAJOR" REPAIR, BID QTY=100 LOCATIONS

ADDED DETAILS -
ADDENDUM NO. 1

PROJECT NO.: 76470-00
ENGR./ARCH.: JMC
DRAWN BY: MPL
DESIGN BY: JMC
CHECKED BY: JMC
CAD FILE: X
DATE: 05/30/2008



MODIFICATION TO THE
STATE CAPITOL PARKING FACILITY
WV DEPARTMENT OF ADMINISTRATION
GENERAL SERVICES DIVISION
CHARLESTON, WEST VIRGINIA

S-10R2
DRAWING NO.

SHEET 1 OF 1

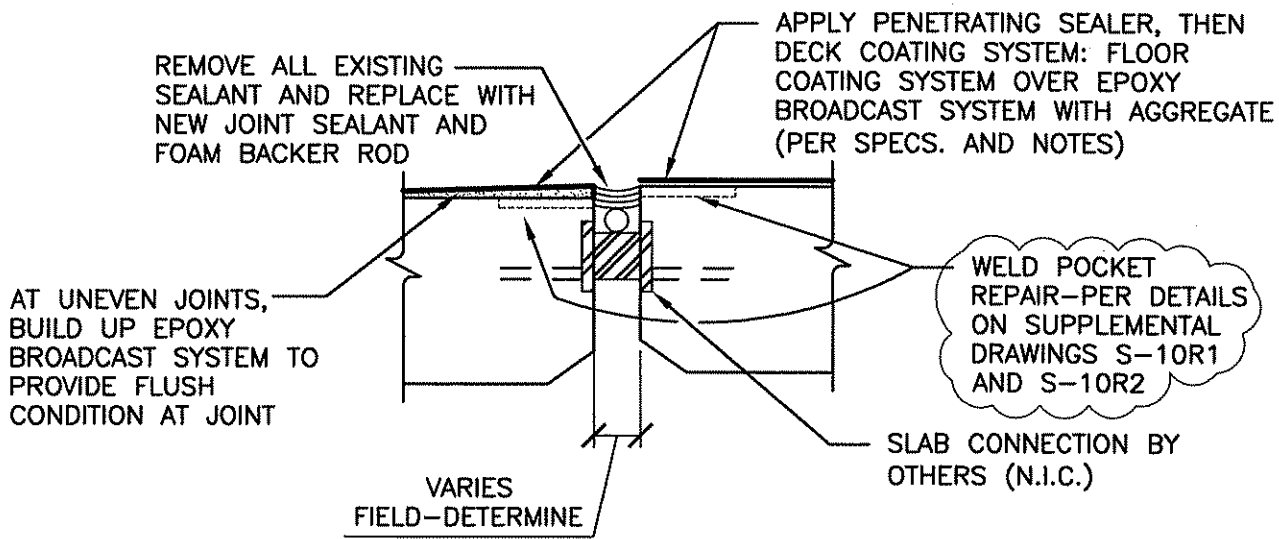

1 (REVISÉD) - TYPICAL SLAB JOINT
 S-10R3 SEALANT AND SLAB COATING

NOTES:

- 1.) PROVIDE SIMILAR DETAIL AT JOINTS IN CAST-IN-PLACE POUR STRIPS.
- 2.) SEE PLANS FOR LEVELS TO RECEIVE SLAB COATING.

REVISED DETAIL -
 ADDENDUM NO. 1

PROJECT NO.: 76470-00
ENGR./ARCH.: JMC
DRAWN BY: MPL
DESIGN BY: JMC
CHECKED BY: JMC
CAD FILE: X
DATE: 05/30/2008



MODIFICATION TO THE
 STATE CAPITOL PARKING FACILITY
 WV DEPARTMENT OF ADMINISTRATION
 GENERAL SERVICES DIVISION
 CHARLESTON, WEST VIRGINIA

S-10R3
DRAWING NO.
SHEET 1 OF 1