



State of West Virginia
 Department of Administration
 Purchasing Division
 2019 Washington Street East
 Post Office Box 50130
 Charleston, WV 25305-0130

Request for Quotation

RFQ NUMBER
 GSD086409

PAGE
 1

ADDRESS CORRESPONDENCE TO ATTENTION OF
 KRISTA FERRELL
 304-558-2596

RFQ COPY
 TYPE NAME/ADDRESS HERE

VENDOR

SHIP TO

DEPARTMENT OF ADMINISTRATION
 GENERAL SERVICES DIVISION
 BUILDING TWENTY THREE
 407 NEVILLE STREET
 BECKLEY WV
 25801 304-558-2317

DATE PRINTED 12/20/2007	TERMS OF SALE	SHIP VIA	F.O.B.	FREIGHT TERMS
BID OPENING DATE: 01/17/2008		BID OPENING TIME 01:30PM		

LINE	QUANTITY	UOP	CAT NO.	ITEM NUMBER	UNIT PRICE	AMOUNT
0001	1	JB		936-75		
REPLACEMENT OF BOILER, BLDG#23 BECKLEY REQUEST FOR QUOTATION THE WEST VIRGINIA PURCHASING DIVISION FOR THE AGENCY, THE WEST VIRGINIA GENERAL SERVICES DIVISION, IS SOLICITING BIDS TO PROVIDE THE AGENCY WITH ALL LABOR AND MATERIALS TO INSTALL A REPLACEMENT BOILER IN BUILDING #23 LOCATED AT 407 NEVILLE STREET IN BECKLEY, WEST VIRGINIA. INCLUDES: REMOVAL OF EXISTING UNIT, PIPING, FLU ATTACHMENTS AND CONTROLS, AND THE REINSTALLATION OF A NEW UNIT TO INCLUDE ALL CONTROLS, PIPING, AND FLU VENTO TO AN OPERATIONAL CONDITION PER THE ATTACHED SPECIFICATIONS. TECHNICAL QUESTIONS CONCERNING THIS PROJECT MUST BE SUBMITTED IN WRITING TO KRISTA FERRELL IN THE WEST VIRGINIA PURCHASING DIVISION VIA MAIL AT THE ADDRESS LISTED IN THE BODY OF THIS RFQ, VIA FAX AT 304-558-4115, OR VIA EMAIL AT KRISTA.S.FERRELL@WV.GOV. (PLEASE NOTE FOR YOUR RECORDS THAT THIS EMAIL ADDRESS HAS RECENTLY CHANGED.) TECHNICAL QUESTIONS INCLUDE, BUT ARE NOT LIMITED TO, SCOPE OF WORK, CLARIFICATION TO BID SPECIFICATIONS, MATERIALS, ETC. DEADLINE FOR TECHNICAL QUESTIONS IS MONDAY, JANUARY 7, 2008 AT THE CLOSE OF BUSINESS. ALL TECHNICAL QUESTIONS RECEIVED, IF ANY, WILL BE ANSWERED BY ADDENDUM AFTER THE DEADLINE. QUESTIONS CONCERNING THE PROCESS BY WHICH A VENDOR						

SEE REVERSE SIDE FOR TERMS AND CONDITIONS

SIGNATURE	TELEPHONE	DATE
TITLE	FEIN	ADDRESS CHANGES TO BE NOTED ABOVE

WHEN RESPONDING TO RFQ, INSERT NAME AND ADDRESS IN SPACE ABOVE LABELED 'VENDOR'

**GENERAL TERMS & CONDITIONS
REQUEST FOR QUOTATION (RFQ) AND REQUEST FOR PROPOSAL (RFP)**

1. Awards will be made in the best interest of the State of West Virginia.
2. The State may accept or reject in part, or in whole, any bid.
3. All quotations are governed by the *West Virginia Code* and the *Legislative Rules* of the Purchasing Division.
4. Prior to any award, the apparent successful vendor must be properly registered with the Purchasing Division and have paid the required \$125.00 registration fee.
5. All services performed or goods delivered under State Purchase Orders/Contracts are to be continued for the term of the Purchase Order/Contract, contingent upon funds being appropriated by the Legislature or otherwise being made available. In the event funds are not appropriated or otherwise available for these services or goods, this Purchase Order/Contract becomes void and of no effect after June 30.
6. Payment may only be made after the delivery and acceptance of goods or services.
7. Interest may be paid for late payment in accordance with the *West Virginia Code*.
8. Vendor preference will be granted upon written request in accordance with the *West Virginia Code*.
9. The State of West Virginia is exempt from federal and state taxes and will not pay or reimburse such taxes.
10. The Director of Purchasing may cancel any Purchase Order/Contract upon 30 days written notice to the seller.
11. The laws of the State of West Virginia and the *Legislative Rules* of the Purchasing Division shall govern all rights and duties under the Contract, including without limitation the validity of this Purchase Order/Contract.
12. Any reference to automatic renewal is hereby deleted. The Contract may be renewed only upon mutual written agreement of the parties.
13. **BANKRUPTCY:** In the event the vendor/contractor files for bankruptcy protection, this Contract may be deemed null and void, and terminated without further order.
14. **HIPAA Business Associate Addendum** - The West Virginia State Government HIPAA Business Associate Addendum (BAA), approved by the Attorney General, and available online at the Purchasing Division's web site (<http://www.state.wv.us/admin/purchase/vrc/hipaa.htm>) is hereby made part of the agreement. Provided that, the Agency meets the definition of a Covered Entity (45 CFR §160.103) and will be disclosing Protected Health Information (45 CFR §160.103) to the vendor.

INSTRUCTIONS TO BIDDERS

1. Use the quotation forms provided by the Purchasing Division.
2. **SPECIFICATIONS:** Items offered must be in compliance with the specifications. Any deviation from the specifications must be clearly indicated by the bidder. Alternates offered by the bidder as **EQUAL** to the specifications must be clearly defined. A bidder offering an alternate should attach complete specifications and literature to the bid. The Purchasing Division may waive minor deviations to specifications.
3. Complete all sections of the quotation form.
4. Unit prices shall prevail in cases of discrepancy.
5. All quotations are considered F.O.B. destination unless alternate shipping terms are clearly identified in the quotation.
6. **BID SUBMISSION:** All quotations must be delivered by the bidder to the office listed below prior to the date and time of the bid opening. Failure of the bidder to deliver the quotations on time will result in bid disqualifications.

SIGNED BID TO:

Department of Administration
Purchasing Division
2019 Washington Street East
Post Office Box 50130
Charleston, WV 25305-0130



State of West Virginia
 Department of Administration
 Purchasing Division
 2019 Washington Street East
 Post Office Box 50130
 Charleston, WV 25305-0130

Request for Quotation

RFQ NUMBER
 GSD086409

PAGE
 2

ADDRESS CORRESPONDENCE TO ATTENTION OF
 KRISTA FERRELL
 304-558-2596

RFQ COPY

TYPE NAME/ADDRESS HERE

VENDOR

SHIP TO

DEPARTMENT OF ADMINISTRATION
 GENERAL SERVICES DIVISION
 BUILDING TWENTY THREE
 407 NEVILLE STREET
 BECKLEY WV
 25801 304-558-2317

DATE PRINTED 12/20/2007	TERMS OF SALE	SHIP VIA	F.O.B.	FREIGHT TERMS
BID OPENING DATE: 01/17/2008		BID OPENING TIME 01:30PM		

LINE	QUANTITY	UOP	CAT NO.	ITEM NUMBER	UNIT PRICE	AMOUNT
<p>MAY SUBMIT A BID TO THE STATE OF WEST VIRGINIA ARE NOT CONSIDERED TECHNICAL QUESTIONS AND MAY BE SUBMITTED AT ANY TIME PRIOR TO THE BID OPENING AND IN ANY FORMAT.</p> <p>A VISIT TO THE SITE MAY BE ARRANGED BY CONTACTING MR. ROGER WINES AT 304-558-5672 OR AT 304-982-0531. ANY QUESTIONS STEMMING FROM SITE VISITS MUST BE SUBMITTED IN ACCORDANCE WITH THE REQUIREMENTS LISTED ABOVE.</p> <p>EXHIBIT 5</p> <p>NOTICE TO PROCEED: THIS CONTRACT IS TO BE PERFORMED WITHIN 30 CALENDAR DAYS AFTER THE NOTICE TO PROCEED IS RECEIVED. THE AGENCY WILL ISSUE A WRITTEN NOTICE TO PROCEED TO THE SUCCESSFUL VENDOR.</p> <p>CANCELLATION: THE DIRECTOR OF PURCHASING RESERVES THE RIGHT TO CANCEL THIS CONTRACT IMMEDIATELY UPON WRITTEN NOTICE TO THE VENDOR IF THE MATERIALS OR WORKMANSHIP SUPPLIED ARE OF AN INFERIOR QUALITY OR DO NOT CONFORM WITH THE SPECIFICATIONS OF THE BID AND CONTRACT HERE IN.</p> <p>WAGE RATES: THE CONTRACTOR OR SUBCONTRACTOR SHALL PAY THE HIGHER OF THE U.S. DEPARTMENT OF LABOR MINIMUM WAGE RATES AS ESTABLISHED FOR KANAWHA COUNTY, PURSUANT TO WEST VIRGINIA CODE 21-5A, ET, SEQ. (PREVAILING WAGE RATES APPLY TO THIS PROJECT)</p> <p>ARBITRATION: ANY REFERENCES MADE TO ARBITRATION OR INTEREST FOR PAYMENTS DUE (EXCEPT FOR ANY INTEREST REQUIRED BY STATE LAW) CONTAINED IN THIS CONTRACT OR IN ANY AMERICAN INSTITUTE OF ARCHITECTS DOCUMENTS PERTAINING TO THIS CONTRACT ARE HEREBY DELETED.</p>						

SEE REVERSE SIDE FOR TERMS AND CONDITIONS

SIGNATURE	TELEPHONE	DATE
-----------	-----------	------

TITLE	FEIN	ADDRESS CHANGES TO BE NOTED ABOVE
-------	------	-----------------------------------

WHEN RESPONDING TO RFQ, INSERT NAME AND ADDRESS IN SPACE ABOVE LABELED 'VENDOR'



State of West Virginia
 Department of Administration
 Purchasing Division
 2019 Washington Street East
 Post Office Box 50130
 Charleston, WV 25305-0130

Request for Quotation

RFQ NUMBER
GSD086409

PAGE
3

ADDRESS CORRESPONDENCE TO ATTENTION OF
KRISTA FERRELL 304-558-2596

RFQ COPY
 TYPE NAME/ADDRESS HERE

VENDOR

SHIP TO

DEPARTMENT OF ADMINISTRATION
 GENERAL SERVICES DIVISION
 BUILDING TWENTY THREE
 407 NEVILLE STREET
 BECKLEY WV
 25801 304-558-2317

DATE PRINTED 12/20/2007	TERMS OF SALE	SHIP VIA	FOB	FREIGHT TERMS
BID OPENING DATE: 01/17/2008		BID OPENING TIME 01:30PM		

LINE	QUANTITY	UOP	CAT NO.	ITEM NUMBER	UNIT PRICE	AMOUNT
<p>WORKERS' COMPENSATION: VENDOR IS REQUIRED TO PROVIDE A CERTIFICATE FROM WORKERS' COMPENSATION IF SUCCESSFUL.</p> <p>ALL OF THE ITEMS CHECKED BELOW WILL BE A REQUIREMENT OF THIS CONTRACT:</p> <p>(XX) INSURANCE: SUCCESSFUL VENDOR SHALL FURNISH PROOF OF COMMERCIAL GENERAL LIABILITY INSURANCE PRIOR TO ISSUANCE OF CONTRACT. UNLESS OTHERWISE SPECIFIED IN THE BID DOCUMENTS, THE MINIMUM AMOUNT OF INSURANCE COVERAGE REQUIRED IS \$250,000.</p> <p>() BUILDERS RISK INSURANCE: SUCCESSFUL VENDOR SHALL FURNISH PROOF OF BUILDERS RISK - ALL RISK INSURANCE IN AN AMOUNT EQUAL TO 100% OF THE AMOUNT OF THE CONTRACT.</p> <p>(XX) BONDS: FIVE PERCENT (5%) OF THE TOTAL AMOUNT OF THE BID PAYABLE TO THE STATE OF WEST VIRGINIA, SHALL BE SUBMITTED WITH EACH BID AS A BID BOND. THE SUCCESSFUL BIDDER SHALL ALSO FURNISH A PERFORMANCE BOND AND LABOR/MATERIAL BOND FOR 100% OF THE AMOUNT OF THE CONTRACT. BONDS MAY BE PROVIDED IN THE FORM OF A CERTIFIED CHECK, IRREVOCABLE LETTER OF CREDIT, OR BOND FURNISHED BY A SOLVENT SURETY COMPANY AUTHORIZED TO DO BUSINESS IN THE STATE OF WEST VIRGINIA. A LETTER OF CREDIT SUBMITTED IN LIEU OF A PERFORMANCE AND LABOR & MATERIAL BOND WILL ONLY BE ALLOWED FOR PROJECTS UNDER \$100,000. PERSONAL OR BUSINESS CHECKS ARE NOT ACCEPCTABLE IN LIEU OF THE 5% BID BOND, PERFORMANCE BOND, OR LABOR AND MATERIAL BOND.</p> <p>() MAINTENANCE BOND: A TWO (2) YEAR MAINTENANCE BOND COVERING THE ROOFING SYSTEM WILL BE A REQUIREMENT OF THE SUCCESSFUL VENDOR.</p>						

SEE REVERSE SIDE FOR TERMS AND CONDITIONS

SIGNATURE	TELEPHONE	DATE
TITLE	FEIN	ADDRESS CHANGES TO BE NOTED ABOVE

WHEN RESPONDING TO RFQ, INSERT NAME AND ADDRESS IN SPACE ABOVE LABELED 'VENDOR'



State of West Virginia
 Department of Administration
 Purchasing Division
 2019 Washington Street East
 Post Office Box 50130
 Charleston, WV 25305-0130

Request for Quotation

RFQ NUMBER
GSD086409

PAGE
4

ADDRESS CORRESPONDENCE TO ATTENTION OF
KRISTA FERRELL
304-558-2596

RFQ COPY

TYPE NAME/ADDRESS HERE

VENDOR

SHIP TO

DEPARTMENT OF ADMINISTRATION
 GENERAL SERVICES DIVISION
 BUILDING TWENTY THREE
 407 NEVILLE STREET
 BECKLEY WV
 25801 304-558-2317

DATE PRINTED 12/20/2007	TERMS OF SALE	SHIP VIA	FOB	FREIGHT TERMS
BID OPENING DATE: 01/17/2008	BID OPENING TIME 01:30PM			

LINE	QUANTITY	UOP	CAT NO.	ITEM NUMBER	UNIT PRICE	AMOUNT
REV. 11/00						
EXHIBIT 7						
DOMESTIC ALUMINUM, GLASS & STEEL IN PUBLIC WORKS PROJECTS						
IN ACCORDANCE WITH WEST VIRGINIA CODE 5-19-1 ET., SEQ., EVERY CONTRACT FOR CONSTRUCTION, RECONSTRUCTION, ALTERATION, REPAIR, IMPROVEMENT OR MAINTENANCE OF PUBLIC WORKS, WHERE THE COST IS MORE THAN \$50,000 AND, IN THE CASE OF STEEL ONLY, WHERE THE COST OF STEEL IS MORE THAN \$50,000 OR WHERE MORE THAN 10,000 POUNDS OF STEEL ARE REQUIRED, THE STATE WILL ACCEPT ONLY ALUMINUM GLASS, OR STEEL PRODUCTS PRODUCED IN THE UNITED STATES. IN ADDITION, ITEMS OF MACHINERY OR EQUIPMENT PURCHASED FOR USE AT THE SITE OF PUBLIC WORKS SHALL BE MADE OF DOMESTIC ALUMINUM, GLASS OR STEEL, UNLESS THE COST OF THE PRODUCT IS LESS THAN \$50,000 OR LESS THAN 10,000 POUNDS OF STEEL ARE USED IN PUBLIC WORKS PROJECTS.						
FOREIGN MADE ALUMINUM, GLASS OR STEEL PRODUCTS MAY BE ACCEPTED ONLY IF THE COST OF DOMESTIC PRODUCTS IS FOUND TO BE UNREASONABLE. SUCH COST IS UNREASONABLE IF IT IS 20% OR MORE HIGHER THAN THE BID PRICE FOR FOREIGN MADE PRODUCTS. IF THE DOMESTIC ALUMINUM, GLASS OR STEEL PRODUCTS TO BE SUPPLIED OR PRODUCED IN A "SUBSTANTIAL LABOR SURPLUS AREA", AS DEFINED BY THE UNITED STATES DEPARTMENT OF LABOR, FOREIGN PRODUCTS MAY BE SUPPLIED ONLY IF DOMESTIC PRODUCTS ARE 30% OR MORE HIGHER IN PRICE THAN THE FOREIGN MADE PRODUCTS.						
IF, PRIOR TO THE AWARD OF A CONTRACT UNDER THE ABOVE PROVISIONS, THE SPENDING OFFICER OF THE SPENDING UNIT DETERMINES THAT THERE EXISTS A BID FOR LIKE FOREIGN						

SEE REVERSE SIDE FOR TERMS AND CONDITIONS

SIGNATURE	TELEPHONE	DATE
TITLE	FEIN	ADDRESS CHANGES TO BE NOTED ABOVE

WHEN RESPONDING TO RFQ, INSERT NAME AND ADDRESS IN SPACE ABOVE LABELED 'VENDOR'



State of West Virginia
 Department of Administration
 Purchasing Division
 2019 Washington Street East
 Post Office Box 50130
 Charleston, WV 25305-0130

Request for Quotation

RFQ NUMBER
 GSD086409

PAGE
 5

ADDRESS CORRESPONDENCE TO ATTENTION OF
 KRISTA FERRELL
 304-558-2596

RFQ COPY

TYPE NAME/ADDRESS HERE

VENDOR

SHIP TO

DEPARTMENT OF ADMINISTRATION
 GENERAL SERVICES DIVISION
 BUILDING TWENTY THREE
 407 NEVILLE STREET
 BECKLEY WV
 25801 304-558-2317

DATE PRINTED 12/20/2007	TERMS OF SALE	SHIP VIA	F.O.B.	FREIGHT TERMS
BID OPENING DATE: 01/17/2008		BID OPENING TIME 01:30PM		

LINE	QUANTITY	UOP	CAT NO.	ITEM NUMBER	UNIT PRICE	AMOUNT
<p>ALUMINUM, GLASS OR STEEL THAT IS REASONABLE AND LOWER THAN THE LOWEST BID DOMESTIC PRODUCTS, THE SPENDING OFFICE MAY REQUEST, IN WRITING, A REEVALUATION AND REDUCTION IN THE LOWEST BID FOR SUCH DOMESTIC PRODUCTS. ALL VENDORS MUST INDICATE IN THEIR BID IF THEY ARE SUPPLYING FOREIGN ALUMINUM, GLASS OR STEEL.</p> <p>REV. 3/88</p> <p>EXHIBIT 9</p> <p>NOTICE FOR ISSUANCE & ACKNOWLEDGEMENT OF CONSTRUCTION PROJECT ADDENDA</p> <p>THE ARCHITECT/ENGINEER AND/OR AGENCY SHALL BE REQUIRED TO ABIDE BY THE FOLLOWING SCHEDULE IN ISSUING CONSTRUCTION PROJECT ADDENDA FOR STATE AGENCIES:</p> <p>(1) THE ARCHITECT/ENGINEER SHALL PREPARE THE ADDENDUM AND A LIST OF ALL PARTIES THAT HAVE PROCURED DRAWINGS AND SPECIFICATIONS FOR THE PROJECT. THE ADDENDUM AND LIST SHALL BE FORWARDED TO THE BUYER IN THE STATE PURCHASING DIVISION. THE ARCHITECT/ENGINEER SHALL ALSO SEND A COPY OF THE ADDENDUM TO THE STATE AGENCY FOR WHICH THE CONTRACT IS ISSUED.</p> <p>(2) THE BUYER SHALL SEND THE ADDENDUM TO ALL INTERESTED PARTIES AND, IF NECESSARY, EXTEND THE BID OPENING DATE. ANY ADDENDUM SHOULD BE RECEIVED BY THE BUYER WITHIN FOURTEEN (14) DAYS PRIOR TO THE BID OPENING DATE.</p> <p>(3) ALL ADDENDA SHOULD BE FORMALLY ACKNOWLEDGED BY ALL BIDDERS AND SUBMITTED TO THE STATE PURCHASING DIVISION. THE SAME RULES AND REGULATIONS</p>						

SEE REVERSE SIDE FOR TERMS AND CONDITIONS

SIGNATURE	TELEPHONE	DATE
TITLE	FEIN	ADDRESS CHANGES TO BE NOTED ABOVE

WHEN RESPONDING TO RFQ, INSERT NAME AND ADDRESS IN SPACE ABOVE LABELED 'VENDOR'



State of West Virginia
 Department of Administration
 Purchasing Division
 2019 Washington Street East
 Post Office Box 50130
 Charleston, WV 25305-0130

Request for Quotation

RFQ NUMBER
 GSD086409

PAGE
 6

ADDRESS CORRESPONDENCE TO ATTENTION OF
 KRISTA FERRELL
 304-558-2596

RFQ COPY
 TYPE NAME/ADDRESS HERE

VENDOR

SHIP TO

DEPARTMENT OF ADMINISTRATION
 GENERAL SERVICES DIVISION
 BUILDING TWENTY THREE
 407 NEVILLE STREET
 BECKLEY WV
 25801 304-558-2317

DATE PRINTED 12/20/2007	TERMS OF SALE	SHIP VIA	F.O.B.	FREIGHT TERMS
BID OPENING DATE: 01/17/2008		BID OPENING TIME 01:30PM		

LINE	QUANTITY	UOP	CAT. NO.	ITEM NUMBER	UNIT PRICE	AMOUNT
<p>THAT APPLY TO THE ORIGINAL BIDDING DOCUMENT SHALL ALSO APPLY TO AN ADDENDUM DOCUMENT. THE ONLY EXCEPTION MAY BE FOR AN ADDENDUM THAT IS ISSUED FOR THE SOLE PURPOSE OF CHANGING A BID OPENING TIME AND/OR DATE.</p> <p>REV. 11/96</p> <p>EXHIBIT 10</p> <p>ADDENDUM ACKNOWLEDGEMENT</p> <p>I HEREBY ACKNOWLEDGE RECEIPT OF THE FOLLOWING CHECKED ADDENDUM(S) AND HAVE MADE THE NECESSARY REVISIONS TO MY PROPOSAL, PLANS AND/OR SPECIFICATION, ETC.</p> <p>ADDENDUM NOS. :</p> <p>NO. 1</p> <p>NO. 2</p> <p>NO. 3</p> <p>NO. 4</p> <p>NO. 5</p> <p>I UNDERSTAND THAT FAILURE TO CONFIRM THE RECEIPT OF TH ADDENDUM(S) MAY BE CAUSE FOR REJECTION OF THE BIDS.</p> <p>VENDOR MUST CLEARLY UNDERSTAND THAT ANY VERBAL REPRESENTATION MADE OR ASSUMED TO BE MADE DURING ANY ORAL DISCUSSION HELD BETWEEN VENDOR'S REPRESENTATIVES AND ANY STATE PERSONNEL IS NOT BINDING. ONLY THE</p>						

SEE REVERSE SIDE FOR TERMS AND CONDITIONS

SIGNATURE	TELEPHONE	DATE
-----------	-----------	------

TITLE	FEIN	ADDRESS CHANGES TO BE NOTED ABOVE
-------	------	-----------------------------------

WHEN RESPONDING TO RFQ, INSERT NAME AND ADDRESS IN SPACE ABOVE LABELED 'VENDOR'



State of West Virginia
 Department of Administration
 Purchasing Division
 2019 Washington Street East
 Post Office Box 50130
 Charleston, WV 25305-0130

Request for Quotation

RFQ NUMBER
 GSD086409

PAGE
 7

ADDRESS CORRESPONDENCE TO ATTENTION OF
 KRISTA FERRELL
 304-558-2596

RFQ COPY
 TYPE NAME/ADDRESS HERE

VENDOR

SHIP TO

DEPARTMENT OF ADMINISTRATION
 GENERAL SERVICES DIVISION
 BUILDING TWENTY THREE
 407 NEVILLE STREET
 BECKLEY WV
 25801 304-558-2317

DATE PRINTED 12/20/2007	TERMS OF SALE	SHIP VIA	F.O.B.	FREIGHT TERMS
BID OPENING DATE: 01/17/2008		BID OPENING TIME 01:30PM		

LINE	QUANTITY	UOP	CAT. NO.	ITEM NUMBER	UNIT PRICE	AMOUNT
INFORMATION ISSUED IN WRITING AND ADDED TO THE SPECIFICATIONS BY AN OFFICIAL ADDENDUM IS BINDING. SIGNATURECOMPANYDATE REV. 11/96 CONTRACTORS LICENSE WEST VIRGINIA STATE CODE 21-11-2 REQUIRES THAT ALL PERSONS DESIRING TO PERFORM CONTRACTING WORK IN THIS STATE MUST BE LICENSED. THE WEST VIRGINIA CONTRACTORS LICENSING BOARD IS EMPOWERED TO ISSUE THE CONTRACTORS LICENSE. APPLICATIONS FOR A CONTRACTORS LICENSE MAY BE MADE BY CONTACTING THE WEST VIRGINIA DIVISION OF LABOR CAPITOL COMPLEX, BUILDING 3, ROOM 319, CHARLESTON, WV 25305. TELEPHONE: (304) 558-7890. WEST VIRGINIA STATE CODE 21-11-11 REQUIRES ANY PROSPECTIVE BIDDER TO INCLUDE THE CONTRACTORS LICENSE NUMBER ON THEIR BID. BIDDER TO COMPLETE: CONTRACTORS NAME: CONTRACTORS LICENSE NO.: THE SUCCESSFUL BIDDER WILL BE REQUIRED TO FURNISH A COPY OF THEIR CONTRACTORS LICENSE PRIOR TO ISSUANCE OF						

SEE REVERSE SIDE FOR TERMS AND CONDITIONS

SIGNATURE	TELEPHONE	DATE
TITLE	FEIN	ADDRESS CHANGES TO BE NOTED ABOVE

WHEN RESPONDING TO RFQ, INSERT NAME AND ADDRESS IN SPACE ABOVE LABELED 'VENDOR'



State of West Virginia
 Department of Administration
 Purchasing Division
 2019 Washington Street East
 Post Office Box 50130
 Charleston, WV 25305-0130

Request for Quotation

RFQ NUMBER
GSD086409

PAGE
8

ADDRESS CORRESPONDENCE TO ATTENTION OF
KRISTA FERRELL 304-558-2596

RFQ COPY

TYPE NAME/ADDRESS HERE

VENDOR

SHIP TO

DEPARTMENT OF ADMINISTRATION
 GENERAL SERVICES DIVISION
 BUILDING TWENTY THREE
 407 NEVILLE STREET
 BECKLEY WV
 25801 304-558-2317

DATE PRINTED	TERMS OF SALE	SHIP VIA	F.O.B.	FREIGHT TERMS
12/20/2007				
BID OPENING DATE: 01/17/2008		BID OPENING TIME 01:30PM		

LINE	QUANTITY	UOP	CAT NO	ITEM NUMBER	UNIT PRICE	AMOUNT
				A PURCHASE ORDER/CONTRACT		
				APPLICABLE LAW		
				THE WEST VIRGINIA STATE CODE, PURCHASING DIVISION RULES AND REGULATIONS, AND THE INFORMATION PROVIDED IN THE "REQUEST FOR QUOTATION" ISSUED BY THE PURCHASING DIVISION IS THE SOLE AUTHORITY GOVERNING THIS PROCUREMENT.		
				ANY INFORMATION PROVIDED IN SPECIFICATION MANUALS, OR ANY OTHER SOURCE, VERBAL OR WRITTEN, WHICH CONTRADICTS OR ALTERS THE INFORMATION PROVIDED FROM THE SOURCES AS DESCRIBED IN THE ABOVE PARAGRAPH IS VOID AND OF NO EFFECT.		
				BANKRUPTCY: IN THE EVENT THE VENDOR/CONTRACTOR FILES FOR BANKRUPTCY PROTECTION, THIS CONTRACT IS AUTOMATICALLY NULL AND VOID, AND IS TERMINATED WITHOUT FURTHER ORDER.		
				REV. 1/2005		
				NOTICE		
				A SIGNED BID MUST BE SUBMITTED TO:		
				DEPARTMENT OF ADMINISTRATION PURCHASING DIVISION BUILDING 15 2019 WASHINGTON STREET, EAST CHARLESTON, WV 25305-0130		
				THE BID SHOULD CONTAIN THIS INFORMATION ON THE FACE OF		

SEE REVERSE SIDE FOR TERMS AND CONDITIONS

SIGNATURE	TELEPHONE	DATE
TITLE	FEIN	ADDRESS CHANGES TO BE NOTED ABOVE

WHEN RESPONDING TO RFQ, INSERT NAME AND ADDRESS IN SPACE ABOVE LABELED 'VENDOR'



State of West Virginia
 Department of Administration
 Purchasing Division
 2019 Washington Street East
 Post Office Box 50130
 Charleston, WV 25305-0130

Request for Quotation

RFQ NUMBER
 GSD086409

PAGE
 9

ADDRESS CORRESPONDENCE TO ATTENTION OF
 KRISTA FERRELL
 304-558-2596

RFQ COPY
 TYPE NAME/ADDRESS HERE

VENDOR

SHIP TO

DEPARTMENT OF ADMINISTRATION
 GENERAL SERVICES DIVISION
 BUILDING TWENTY THREE
 407 NEVILLE STREET
 BECKLEY WV
 25801 304-558-2317

DATE PRINTED	TERMS OF SALE	SHIP VIA	F.O.B.	FREIGHT TERMS
12/20/2007				
BID OPENING DATE: 01/17/2008		BID OPENING TIME 01:30PM		

LINE	QUANTITY	UOP	CAT NO	ITEM NUMBER	UNIT PRICE	AMOUNT
THE ENVELOPE OR THE BID MAY NOT BE CONSIDERED: SEALED BID BUYER: KRISTA FERRELL-FILE 21 REQ. NO.: GSD086409 BID OPENING DATE: 01/16/2007 BID OPENING TIME: 1:30 PM PLEASE PROVIDE A FAX NUMBER IN CASE IT IS NECESSARY TO CONTACT YOU REGARDING YOUR BID: ----- PLEASE PRINT OR TYPE NAME OF PERSON TO CONTACT CONCERNING THIS QUOTE: ----- ***** THIS IS THE END OF RFQ GSD086409 ***** TOTAL: _____						

SEE REVERSE SIDE FOR TERMS AND CONDITIONS

SIGNATURE	TELEPHONE	DATE
TITLE	FEIN	ADDRESS CHANGES TO BE NOTED ABOVE

WHEN RESPONDING TO RFQ, INSERT NAME AND ADDRESS IN SPACE ABOVE LABELED 'VENDOR'

**REQUEST FOR QUOTATIONS
BUILDING 23, REPLACEMENT BOILER PROJECT
RFQ #GSD086409**

The WV Purchasing Division for the agency, Department of Administration's General Services Division (GSD), is soliciting a lump sum quotation for equipment purchase and installation of a replacement boiler for Building 23 located at 407 Neville Street, Beckley WV. This RFQ also includes removal of existing unit, piping, flu attachments and controls and reinstallation of a new unit to include all controls, piping, and flu vent to an operational condition.

The following are included in this bid package:

1. These specifications
2. Attachment I: Triad boiler specifications for reference.
3. Attachment II: Triad boiler drawings for reference.

Any services contracted for prior to receipt of the signed purchase order and written notice to proceed letter shall be at the Bidder's risk.

Successful Bidder will be given thirty (30) calendar days from the written notice to proceed to complete the project.

The Bidder agrees that this Bid shall not be withdrawn for a period of ninety (90) consecutive calendar days following the date for receipt of bids.

An inspection of the facility may be arranged by contacting General Services, Roger Wines at (304) 558-5672 or (304) 982-0531.

Technical questions may be directed to Krista Ferrell, Senior Buyer, West Virginia State Purchasing Division via email at krista.s.ferrell@wv.gov or via fax to (304)558-4115.

Deadline for technical questions is January 7, 2007 by the close of business. Questions concerning actual bid submission may be submitted to the buyer at any time and in any format.

GENERAL SPECIFICATIONS

1. All work will be performed in compliance with all applicable safety regulations, subject to verification and inspection by GSD safety representatives.
2. Work schedules will be reviewed and approved by GSD. Contractor will be afforded access as required to complete work on schedule.
3. Scheduled work may not begin until successful vendor has received a signed purchase order and notice to proceed letter.
4. All work will be inspected and approved by GSD prior to approval and payment of invoices.

5. Any areas identified requiring abatement will be completed by GSD under a separate abatement/ re-insulation contract.
6. Two copies (one original and one copy) of invoice will be submitted for payment and shall be mailed to the following address:

General Services Division
1900 Kanawha Blvd. E.
Building 1, Room MB-60
Charleston, WV 25305
Attn: Business Manager

PAGE 2 OF 3

DETAILED SPECIFICATIONS

Furnish labor, equipment and miscellaneous supplies to provide and install a Triad Series 1600 SH Steam steel fire tube boiler, or its equal.

The contractor will:

1. Remove existing unit and associated piping for disposal.
2. Provide for equipment as outlined in Attachment 1.
3. Install new boiler with feed water tank and pumps.
4. Start-up and check for proper operation.

ADDITIONAL INFORMATION:

1. Contract will be awarded to the qualified bidder with the lowest overall cost for project. "Qualified bidder" is defined as one that has met all WV licensing or registration requirements to include WV Contractors License as applicable.
2. Successful vendor must be registered with The WV State Purchasing Division. This may require payment of an annual fee of \$125.00. For information on vendor registration contact WV Vendor Registration at (304) 558-2311.
3. Vendor must guarantee payment of applicable prevailing wage rates as directed by wage schedule for Kanawha County from the West Virginia Dept. of Labor.
4. Vendor must complete a WV Purchasing Affidavit.
5. Successful bidder must be registered with WVFIMS by submission of W9 for taxpayer identification. For information on W9 submission contact 558-4587.
6. Successful bidder must possess a valid State of West Virginia Contractor's License or waiver from the West Virginia Division of Labor.

BID FORM:

Total price to provide and install a Triad Series 1600 Boiler, or equal, at our facility at 407 Neville Street in Beckley, WV:

_____ (total bid)

Attachment 1

TRIAD BOILER SYSTEMS, INC.
Specification for Series 1600 SH Steam, steel, fire tube boiler..

GENERAL PRODUCT DESCRIPTION:

1. Furnish and install a modular steel boiler with a total rated input of 1,300 MBH. Each boiler shall have a rated output of 1,079 MBH when fired with natural gas.
2. Acceptable boiler design will be TRIAD Series 1600 designed for steam heating applications.
3. Boilers shall be in accordance with Section IV of the ASME Boiler and Pressure Vessel Code and must be tested, stamped, and approved for 15 psi operating pressure and bear the ASME symbol. Each boiler shall be registered with the National Board of Boiler and Pressure Vessel Inspectors.

BOILER DESIGN:

1. Boilers shall be of a water-backed fire tube design and fired with AGA or UL listed burners. Vessel walls shall be 1/4" thick boilerplate. Top and bottom tube sheets shall be 3/8" thick boilerplate. Fire tubes shall be of 12 gauge steel, no fewer than 70 vertical tubes, and no less than 2" dia. Firetubes shall be expanded/rolled into the top and bottom tube sheets; welding of tubes to tube sheet will not be permitted. Top and bottom tube sheets and tubes shall be accessible for easy inspection and cleaning. Boilers shall include a drain and have bolt-style leveling legs or rails. Each boiler shall be encased in a painted metal jacket with 1" high performance insulation.
2. All valving, fixed orifices, and associated piping shall be as recommended by the manufacturer so return water from the main enters the lower front of each boiler and supply exits the top rear of each boiler.
3. Provide a condensate feed system consisting of a tank and pump properly sized in accordance with the factory recommendations for this application.
4. The maximum rated temperature shall be 250°F with nominal upper limits set at 220°F and operated at 218°F. The units shall operate on 120 volt, single phase, 60 Hz power.
5. Boiler equipment, associated manifolding, and control panel shall be manufactured by TRIAD Boiler Systems. All boiler controls shall be UL Listed or Recognized.

BOILER TRIM:

The following trim items shall be integral to the boiler and factory installed and wired:

1. Low Water Cut-Off with Manual Reset, Test Light, & Test Button internal to the boiler (probe type) that prevents operations if the boiler water level falls below a nominal operating level.
2. Operating High Pressure Limit control.
3. Safety High Pressure Limit Control that is a second high-limit with manual reset that prevents burner operation above nominal operating conditions.
4. Pressure/ temperature gauge of suitable range for monitoring operations.
5. High Visibility "Call for Heat" Light to indicate when the boiler circuitry has been activated.
6. Disconnect switch.
7. ASME relief valve with a setting of 15psi.
8. Observation port for flame inspection.

BURNERS:

The horizontally mounted burner shall be a PowerFlame atmospheric burner and fire natural gas. The burner and gas train shall be of a design that produces flame retention with rapid mixing of the fuel and combustion air.

The entire fuel burner system and its installation shall conform with applicable codes. The burner shall contain manufacturer's pre-wired controls. The burner shall normally operate without objectionable noise, vibration, or pulsation with not more than 20 percent excess air and with no CO in the products of combustion. The burner to boiler interface shall allow for ready installation and removal for inspection and cleaning.

The following trim and controls shall be supplied for the burner:

- A. Air inlet shutter.
- B. Combustion safety control with integral pilot ignition.
- C. Internal gas pilot with combustion ignition electrode and sensor.
- D. Pilot solenoid valve.
- E. Pilot gas pressure regulator.
- F. Diaphragm air flow switch.
- G. Combination gas valve & regulator.
- H. Manual leak test valve.
- I. Second safety shutoff gas valve.

The Burner Control Panel shall include the following:

- 1. Indicating lights for power on and fuel on.
- 2. On-off switch.
- 3. Cabinet door with dust seal, key lock and piano type hinge.
- 4. Color coded wiring.

Units shall require only setting on floor with ready attachment to required power, suitably provided fuel, adequate venting, and appropriate water to operate. Warranty shall include 1 year parts and workmanship; 10 years on pressure bound vessel, 20 years against leaks caused by thermal shock. Boiler packages shall be as supplied by TRIAD Boiler Systems, Inc. of West Chicago, IL 60185.



West Chicago, IL 60185
 Phone: 630-562-2700
www.com.com

TRIAD BOILER SYSTEMS, INC.
SERIES 1600 STEAM BOILER

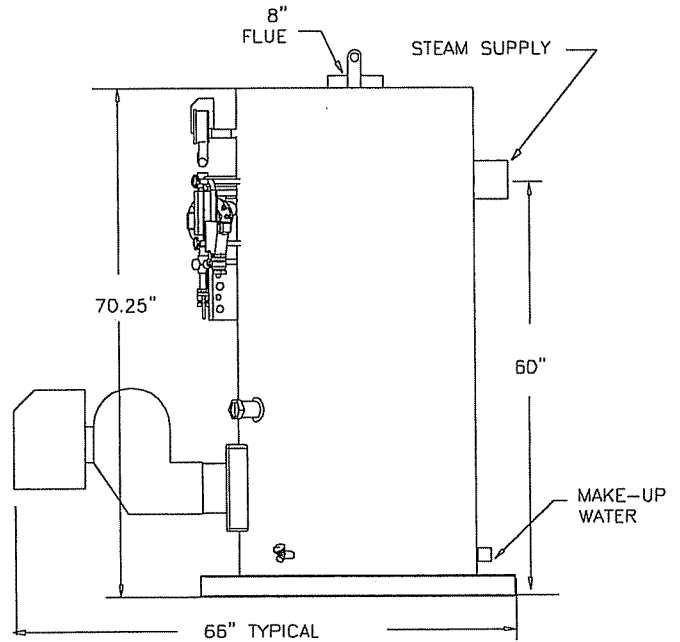
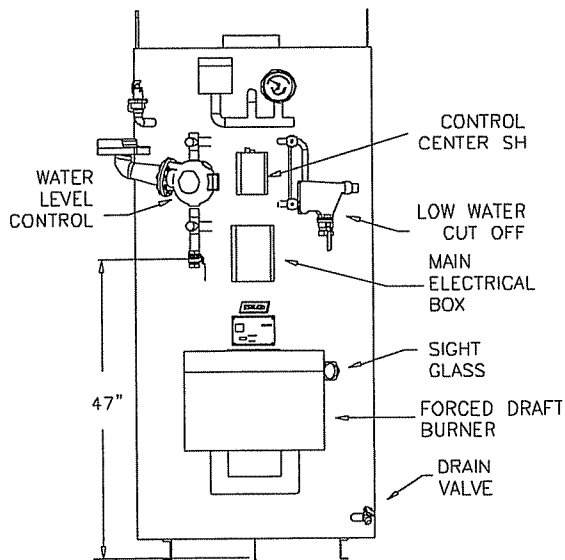
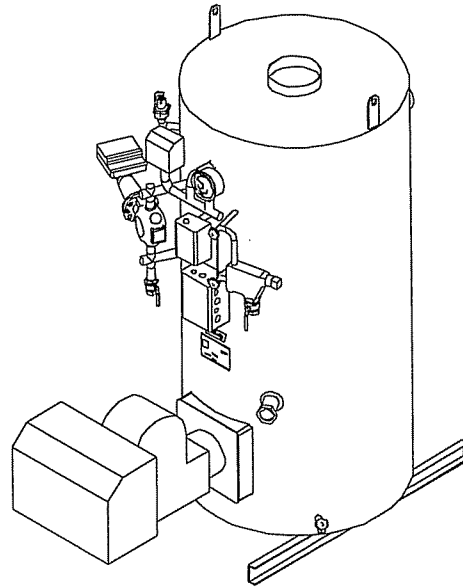
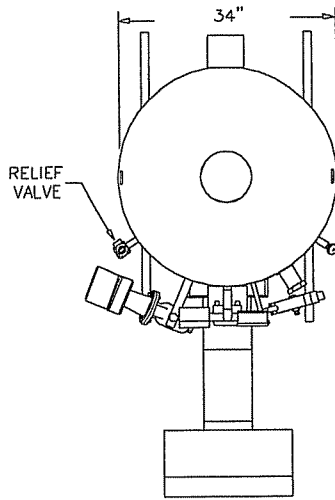

Note: Dimensions subject to change without notice.

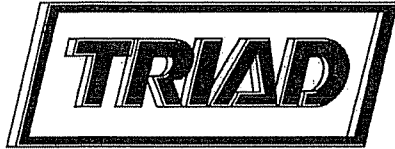

TRIAD BOILER SYSTEMS, INC.
SERIES 1600 STEAM (Model 1600 GMS)

The Series 1600 is a steel, vertical firetube packaged boiler with a water-backed combustion chamber equipped with high-efficiency turbulators. Boilers come fully wired, and fit through a 34" doorway.

STANDARD EQUIPMENT:

Low/High/Off Power Burner (UL Listed)
 P7810C Solid State Pressure Control, Manual Reset
 150 Water Level Control
 67 Low Water Cut-Off, Manual Reset
 Honeywell Control Relay
 Gauge Glass Assembly
 Pressure Gauge
 Operating Light
 15 psi Relief Valve
 Lifting Lugs
 Vessel Pressure Rating of 125 PSI
 UL Listed Boiler/Burner Package.

OPTIONAL EQUIPMENT:

Gas Fired (NG or Propane), Oil Fired, or Dual Fuel Burners
 UL, IRI, FM and CSD-1 Compliance
 Low/High/Low and Modulating Gas Trains
 Sealed Combustion Air Intake
 Barometric Dampers

SPECIFICATIONS:

<i>Input BTU/Hr</i>	<i>Output BTU/Hr</i>	<i>Efficiency</i>	<i>HP Rating</i>	<i>Steam lbs./hr</i>
1,200,000	996,000	83.0%	29.8	1,027
1,300,000	1,079,000	83.0%	32.3	1,112
1,400,000	1,162,000	83.0%	34.7	1,198
1,600,000	1,328,000	83.0%	39.7	1,369
1,700,000	1,411,000	83.0%	42.2	1,454

Note: Typical for Natural Gas. - Oil or LP burner data may vary.

APPLICATIONS:

Space Heating and Process up to 15psi

CLEARANCES & CONNECTION SIZES:

10" between boilers, 10" from front of burner, 6" steam outlet, 2.5" makeup water.

CONTROL:

The Series 1600 can operate on its own controls, but a TRIAD microprocessor control panel is recommended for sequencing more than two boilers to minimize run-time and fuel usage.

FLUE: Category I when applied appropriately.

POWER: 120V, 60Hz, Single Phase, fused for 30 amps. (208/230/460 – 3 phase optional). Min / Max gas pressure, typically 4.9" / 14" WC

WEIGHT/VOLUME:

Shipping Weight – 1,700 lbs.
 Operating Weight - 2,575 lbs.
 Volume – 90 gallons

TRIAD BOILER REPRESENTATIVE:

TRIAD Boiler Systems, Inc.

West Chicago, IL 60185
 Phone: 630-562-2700
 Fax: 630-562-2800
 Web: www.com

Agency _____
REQ.P.O# _____

BID BOND

KNOW ALL MEN BY THESE PRESENTS, That we, the undersigned, _____
_____ of _____, _____, as Principal, and _____
_____ of _____, _____, a corporation organized and existing under the laws of the State of _____
_____ with its principal office in the City of _____, as Surety, are held and firmly bound unto the State
of West Virginia, as Obligee, in the penal sum of _____ (\$ _____) for the payment of which,
well and truly to be made, we jointly and severally bind ourselves, our heirs, administrators, executors, successors and assigns.

The Condition of the above obligation is such that whereas the Principal has submitted to the Purchasing Section of the
Department of Administration a certain bid or proposal, attached hereto and made a part hereof, to enter into a contract in writing for

NOW THEREFORE,

- (a) If said bid shall be rejected, or
- (b) If said bid shall be accepted and the Principal shall enter into a contract in accordance with the bid or proposal attached
hereto and shall furnish any other bonds and insurance required by the bid or proposal, and shall in all other respects perform the
agreement created by the acceptance of said bid, then this obligation shall be null and void, otherwise this obligation shall remain in full
force and effect. It is expressly understood and agreed that the liability of the Surety for any and all claims hereunder shall, in no event,
exceed the penal amount of this obligation as herein stated.

The Surety, for the value received, hereby stipulates and agrees that the obligations of said Surety and its bond shall be in no
way impaired or affected by any extension of the time within which the Obligee may accept such bid, and said Surety does hereby
waive notice of any such extension.

IN WITNESS WHEREOF, Principal and Surety have hereunto set their hands and seals, and such of them as are corporations
have caused their corporate seals to be affixed hereunto and these presents to be signed by their proper officers, this
_____ day of _____, 20_____.

Principal Corporate Seal

(Name of Principal)

By _____
(Must be President or
Vice President)

(Title)

Surety Corporate Seal

(Name of Surety)

Attorney-in-Fact

**IMPORTANT – Surety executing bonds must be licensed in West Virginia to transact surety insurance. Raised corporate seals
must be affixed, a power of attorney must be attached.**

BID BOND PREPARATION INSTRUCTIONS

AGENCY (A)
RFQ/RFP# (B)

Bid Bond

- (A) WV State Agency
(Stated on Page 1 "Spending Unit")
Request for Quotation Number (upper
right corner of page #1)
(C) Your Company Name
(D) City, Location of your Company
(E) State, Location of your Company
(F) Surety Corporate Name
(G) City, Location of Surety
(H) State, Location of Surety
(I) State of Surety Incorporation
(J) City of Surety Incorporation
(K) Minimum amount of acceptable bid
bond is 5% of total bid. You may state
"5% of bid" or a specific amount on
this line in words.
(L) Amount of bond in figures
(M) Brief Description of scope of work
(N) Day of the month
(O) Month
(P) Year
(Q) Name of Corporation
(R) Raised Corporate Seal of Principal
(S) Signature of President or Vice
President
(T) Title of person signing
(U) Raised Corporate Seal of Surety
(V) Corporate Name of Surety
(W) Signature of Attorney in Fact of the
Surety

KNOW ALL MEN BY THESE PRESENTS, That we, the undersigned,
(C) of (D), (E)
as Principal, and (F) of (G),
(H), a corporation organized and existing under the laws
of the State of (I) with its principal office in the City of
(J), as Surety, are held and firmly bound unto The State
of West Virginia, as Obligee, in the penal sum of (K)
(\$ (L)) for the payment of which, well and truly to be made,
we jointly and severally bind ourselves, our heirs, administrators, executors,
successors and assigns.

The Condition of the above obligation is such that whereas the Principal
has submitted to the Purchasing Section of the Department of Administration
a certain bid or proposal, attached hereto and made a part hereof to enter into a
contract in writing for (M)

NOW THEREFORE.

(a) If said bid shall be rejected, or
(b) If said bid shall be accepted and the Principal shall enter into a
contract in accordance with the bid or proposal attached hereto and shall furnish
any other bonds and insurance required by the bid or proposal, and shall in all
other respects perform the agreement created by the acceptance of said bid then
this obligation shall be null and void, otherwise this obligation shall remain in full
force and effect. It is expressly understood and agreed that the liability of the
Surety for any and all claims hereunder shall, in no event, exceed the penal
amount of this obligation as herein stated

The Surety for value received, hereby stipulates and agrees that the
obligations of said Surety and its bond shall be in no way impaired or affected by
any extension of time within which the Obligee may accept such bid: and said
Surety does hereby waive notice of any such extension.

IN WITNESS WHEREOF, Principal and Surety have hereunto set their
hands and seals, and such of them as are corporations have caused their corporate
seals to be affixed hereto and these presents to be signed by their proper officers,
this (N) day of (O), 20 (P).

NOTE: Dated, Power of Attorney with Raised
Surety Seal must accompany this bid
bond.

Principal Corporate Seal (Q)
(Name of Principal)
By (S)
(Must be President or
Vice President)
(T)
Title
(U)
Surety Corporate Seal (V)
(Name of Surety)
(W)
Attorney-in-Fact

IMPORTANT - Surety executing bonds must be licensed in West Virginia to
transact surety insurance. Raised Corporate Seals must be affixed and a Power of
Attorney must be attached.

RFQ No. _____

STATE OF WEST VIRGINIA
Purchasing Division

PURCHASING AFFIDAVIT

West Virginia Code §5A-3-10a states: No contract or renewal of any contract may be awarded by the state or any of its political subdivisions to any vendor or prospective vendor when the vendor or prospective vendor or a related party to the vendor or prospective vendor is a debtor and the debt owed is an amount greater than one thousand dollars in the aggregate

DEFINITIONS:

"Debt" means any assessment, premium, penalty, fine, tax or other amount of money owed to the state or any of its political subdivisions because of a judgment, fine, permit violation, license assessment, defaulted workers' compensation premium, penalty or other assessment presently delinquent or due and required to be paid to the state or any of its political subdivisions, including any interest or additional penalties accrued thereon.

"Debtor" means any individual, corporation, partnership, association, limited liability company or any other form or business association owing a debt to the state or any of its political subdivisions. "Political subdivision" means any county commission; municipality; county board of education; any instrumentality established by a county or municipality; any separate corporation or instrumentality established by one or more counties or municipalities, as permitted by law; or any public body charged by law with the performance of a government function or whose jurisdiction is coextensive with one or more counties or municipalities. "Related party" means a party, whether an individual, corporation, partnership, association, limited liability company or any other form or business association or other entity whatsoever, related to any vendor by blood, marriage, ownership or contract through which the party has a relationship of ownership or other interest with the vendor so that the party will actually or by effect receive or control a portion of the benefit, profit or other consideration from performance of a vendor contract with the party receiving an amount that meets or exceed five percent of the total contract amount.

EXCEPTION: The prohibition of this section does not apply where a vendor has contested any tax administered pursuant to chapter eleven of this code, workers' compensation premium, permit fee or environmental fee or assessment and the matter has not become final or where the vendor has entered into a payment plan or agreement and the vendor is not in default of any of the provisions of such plan or agreement.

LICENSING: Vendors must be licensed and in good standing in accordance with any and all state and local laws and requirements by any state or local agency of West Virginia, including, but not limited to, the West Virginia Secretary of State's Office, the West Virginia Tax Department, West Virginia Insurance Commission, or any other state agencies or political subdivision. Furthermore, the vendor must provide all necessary releases to obtain information to enable the Director or spending unit to verify that the vendor is licensed and in good standing with the above entities.

CONFIDENTIALITY: The vendor agrees that he or she will not disclose to anyone, directly or indirectly, any such personally identifiable information or other confidential information gained from the agency, unless the individual who is the subject of the information consents to the disclosure in writing or the disclosure is made pursuant to the agency's policies, procedures and rules. Vendors should visit www.state.wv.us/admin/purchase/privacy for the Notice of Agency Confidentiality Policies.

Under penalty of law for false swearing (West Virginia Code, §61-5-3), it is hereby certified that the vendor acknowledges the information in this said affidavit and are in compliance with the requirements as stated.

Vendor's Name: _____

Authorized Signature: _____ Date: _____