



State of West Virginia  
 Department of Administration  
 Purchasing Division  
 2019 Washington Street East  
 Post Office Box 50130  
 Charleston, WV 25305-0130

# Request for Quotation

RFQ NUMBER  
**DEFK8220**

PAGE  
**1**

ADDRESS CORRESPONDENCE TO ATTENTION OF  
**JOHN ABBOTT**  
**304-558-2544**

VENDOR

**RFQ COPY**  
 TYPE NAME/ADDRESS HERE

SHIP TO

**DIV ENGINEERING & FACILITIES**  
**ARMORY BOARD SECTION**  
  
**1707 COONSKIN DRIVE**  
**CHARLESTON, WV**  
**25311-1099 341-6368**

DATE PRINTED	TERMS OF SALE	SHIP VIA	F.O.B.	FREIGHT TERMS
<b>05/05/2008</b>				

BID OPENING DATE: **05/15/2008** BID OPENING TIME **01:30PM**

LINE	QUANTITY	UOP	CAT. NO.	ITEM NUMBER	UNIT PRICE	AMOUNT
				<b>ADDENDUM #01</b>		
				<b>THIS ADDENDUM IS ISSUED TO MODIFY, ADD TO, AND DELETE THE REQUIREMENTS OF THE ORIGINAL REQUEST FOR QUOTATION SPECIFICATIONS, PER THE ATTACHED. INCLUDED IS BONDING FORMS FOR VENDOR'S USE.</b>		
<b>0001</b>	<b>1</b>	<b>LS</b>		<b>550-43</b>		
				<b>TWO-STRAND CABLE VEHICULAR BARRIER</b>		
				<b>***** THIS IS THE END OF RFQ DEFK8220 ***** TOTAL:</b>		

SEE REVERSE SIDE FOR TERMS AND CONDITIONS

SIGNATURE	TELEPHONE	DATE
TITLE	FEIN	ADDRESS CHANGES TO BE NOTED ABOVE

WHEN RESPONDING TO RFQ, INSERT NAME AND ADDRESS IN SPACE ABOVE LABELED 'VENDOR'

**GENERAL TERMS & CONDITIONS  
REQUEST FOR QUOTATION (RFQ) AND REQUEST FOR PROPOSAL (RFP)**

1. Awards will be made in the best interest of the State of West Virginia.
2. The State may accept or reject in part, or in whole, any bid.
3. All quotations are governed by the *West Virginia Code* and the *Legislative Rules* of the Purchasing Division.
4. Prior to any award, the apparent successful vendor must be properly registered with the Purchasing Division and have paid the required \$125.00 registration fee.
5. All services performed or goods delivered under State Purchase Orders/Contracts are to be continued for the term of the Purchase Order/Contract, contingent upon funds being appropriated by the Legislature or otherwise being made available. In the event funds are not appropriated or otherwise available for these services or goods, this Purchase Order/Contract becomes void and of no effect after June 30.
6. Payment may only be made after the delivery and acceptance of goods or services.
7. Interest may be paid for late payment in accordance with the *West Virginia Code*.
8. Vendor preference will be granted upon written request in accordance with the *West Virginia Code*.
9. The State of West Virginia is exempt from federal and state taxes and will not pay or reimburse such taxes.
10. The Director of Purchasing may cancel any Purchase Order/Contract upon 30 days written notice to the seller.
11. The laws of the State of West Virginia and the *Legislative Rules* of the Purchasing Division shall govern all rights and duties under the Contract, including without limitation the validity of this Purchase Order/Contract.
12. Any reference to automatic renewal is hereby deleted. The Contract may be renewed only upon mutual written agreement of the parties.
13. **BANKRUPTCY:** In the event the vendor/contractor files for bankruptcy protection, this Contract may be deemed null and void, and terminated without further order.
14. **HIPAA Business Associate Addendum** - The West Virginia State Government HIPAA Business Associate Addendum (BAA), approved by the Attorney General, and available online at the Purchasing Division's web site (<http://www.state.wv.us/admin/purchase/vrc/hipaa.htm>) is hereby made part of the agreement. Provided that, the Agency meets the definition of a Covered Entity (45 CFR §160.103) and will be disclosing Protected Health Information (45 CFR §160.103) to the vendor.

---

**INSTRUCTIONS TO BIDDERS**

1. Use the quotation forms provided by the Purchasing Division.
2. **SPECIFICATIONS:** Items offered must be in compliance with the specifications. Any deviation from the specifications must be clearly indicated by the bidder. Alternates offered by the bidder as **EQUAL** to the specifications must be clearly defined. A bidder offering an alternate should attach complete specifications and literature to the bid. The Purchasing Division may waive minor deviations to specifications.
3. Complete all sections of the quotation form.
4. Unit prices shall prevail in cases of discrepancy.
5. All quotations are considered F.O.B. destination unless alternate shipping terms are clearly identified in the quotation.
6. **BID SUBMISSION:** All quotations must be delivered by the bidder to the office listed below prior to the date and time of the bid opening. Failure of the bidder to deliver the quotations on time will result in bid disqualifications.

**SIGNED BID TO:**

Department of Administration  
Purchasing Division  
2019 Washington Street East  
Post Office Box 50130  
Charleston, WV 25305-0130

**DEFK8220 - ADDENDUM #01**

- 1. DELETE: First Line Paragraph B, Page 10**
- 2. DELETE: First Line Paragraph D, Page 10**
- 3. DELETE Page 13 & 14, General Notes**
- 4. DELETE: Page 16, Brace Panel W/ Deadmen Detail**
- 5. DELETE: Page Page 17, Pipe Guard Detail,**
- 6. DELETE: Page 20, Deadman Detail**
- 7. DELETE: Page 21, Deadman Anchor**
- 8. DELETE: Page 24, End Panel Elevation**
- 9. DELETE: Page 25, Corner Plan**
- 10. DELETE: Page 26, End Panel Plan**
- 11. ADD: A-1, End of Run Detail, Elevation View**
- 12. ADD: A-2, End of Run Detail, Plan View**
- 13. ADD A-3, Corner Detail, Plan View**
- 14. CHANGE: Page 15, Segment 1 & 2 are continuous**
- 15. CHANGE: Page 15, Corners will be installed between Segments 1&2, 5&8, 10&11, 17&18, And 19&20.**

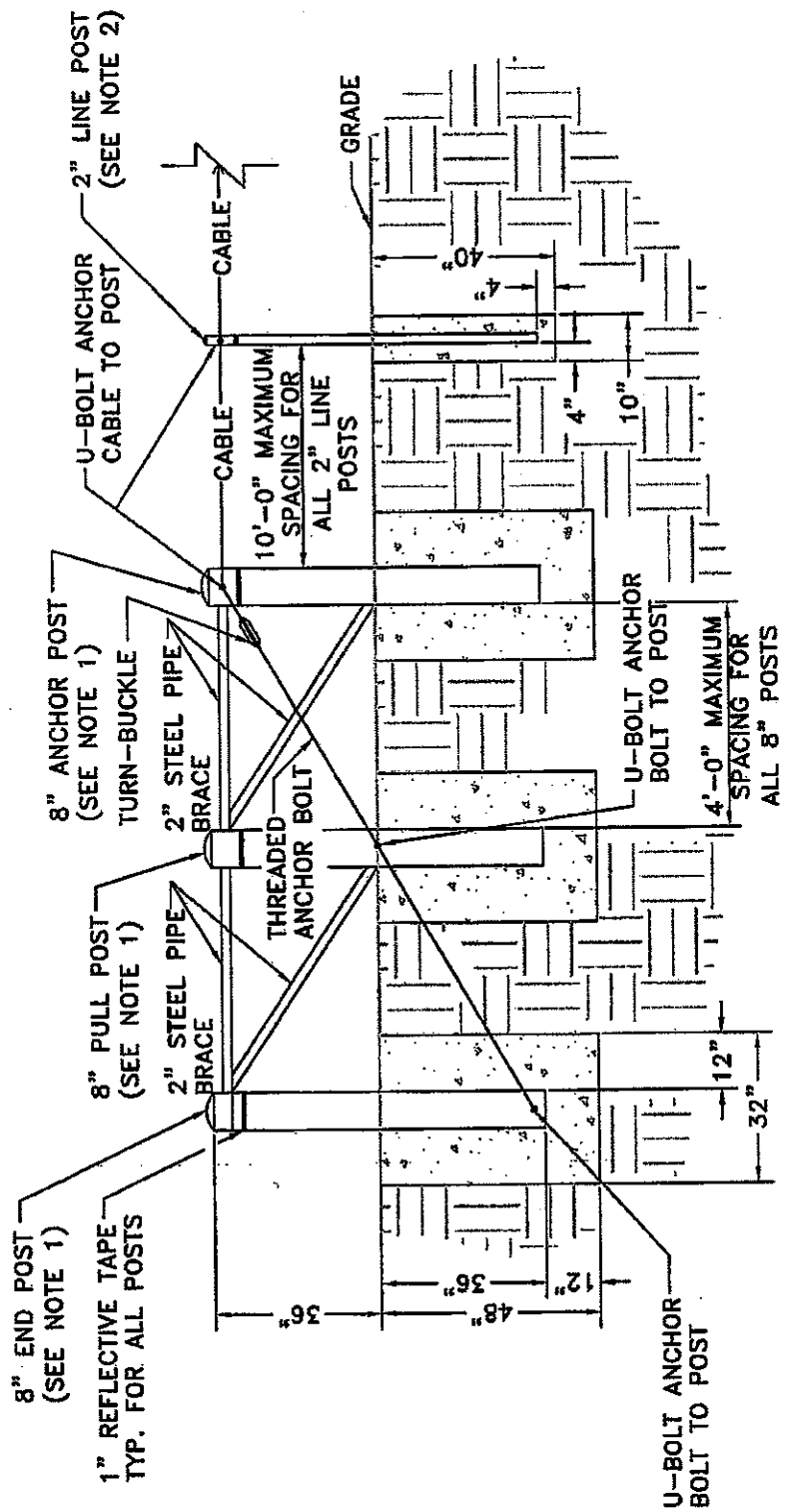

- NOTES:
1. 8"x 6' CONCRETE FILLED TO DOME; STEEL PIPE BOLLARD, WITH ONE WRAP OF 1" REFLECTIVE TAPE.
  2. 2"x 6' LINE POST AND CAP, WITH ONE WRAP OF 1" REFLECTIVE TAPE.

END OF RUN DETAIL  
ELEVATION VIEW

A-1

- NOTES:
1. 8"X 6' CONCRETE FILLED TO DOME, STEEL PIPE BOLLARD, WITH ONE WRAP OF 1" REFLECTIVE TAPE.
  2. 2"X 6' LINE POST AND CAP, WITH ONE WRAP OF 1" REFLECTIVE TAPE.

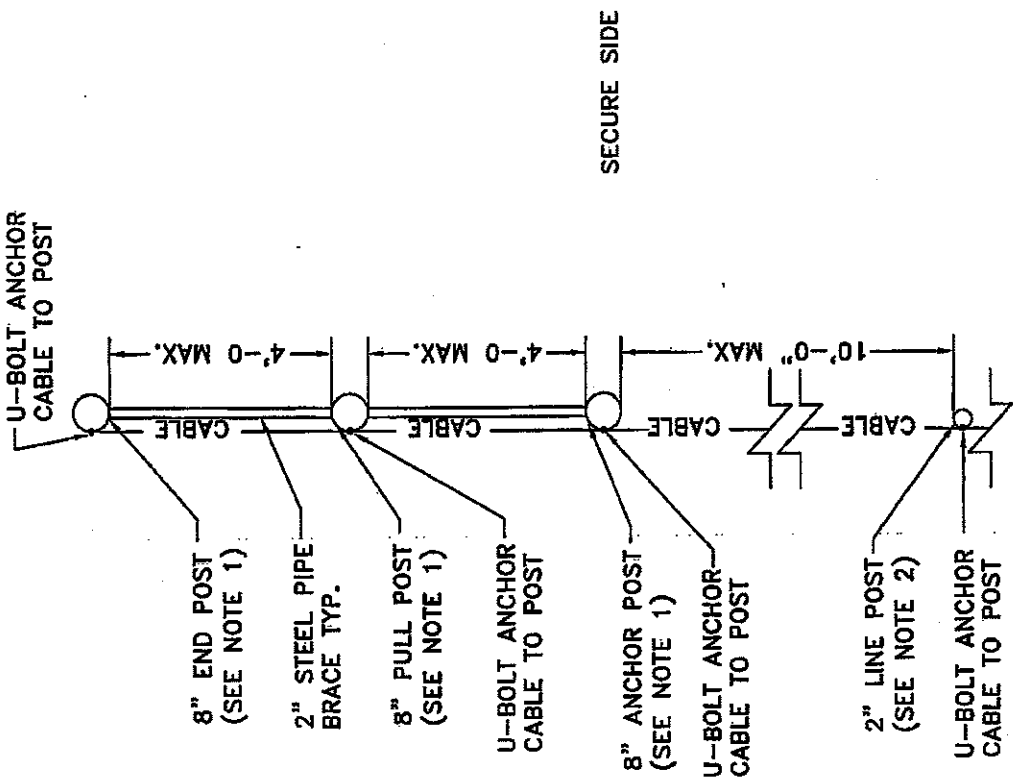

END OF RUN DETAIL  
 PLAN VIEW

A-2

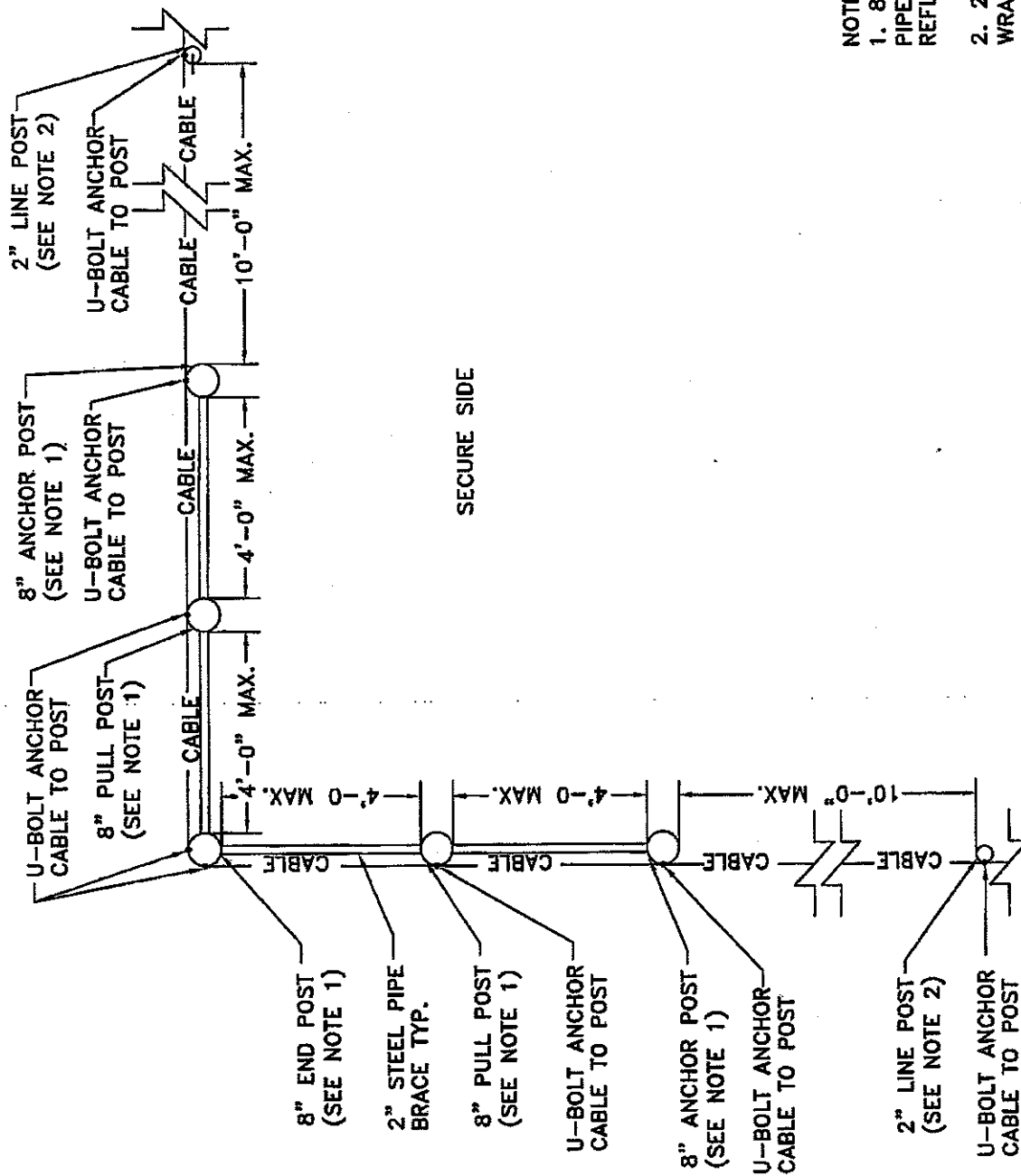

SECURE SIDE

NOTES:

- 1. 8"X6' CONCRETE FILLED TO DOME, STEEL PIPE BOLLARD, WITH ONE WRAP OF 1" REFLECTIVE TAPE.
- 2. 2"X6' LINE POST AND CAP, WITH ONE WRAP OF 1" REFLECTIVE TAPE.
- 3. ELEVATION VIEW FOR CORNER SAME AS END OF RUN DETAIL, WITH A COMMON 8" END POST.

CORNER DETAIL

PLAN VIEW

A-B

**BID BOND PREPARATION INSTRUCTIONS**

AGENCY \_\_\_\_\_ (A)  
 RFQ/RFP# \_\_\_\_\_ (B)

**Bid Bond**

- (A) WV State Agency  
 (Stated on Page 1 "Spending Unit")  
 Request for Quotation Number (upper  
 right corner of page #1)
- (C) Your Company Name
- (D) City, Location of your Company
- (E) State, Location of your Company
- (F) Surety Corporate Name
- (G) City, Location of Surety
- (H) State, Location of Surety
- (I) State of Surety Incorporation
- (J) City of Surety Incorporation
- (K) Minimum amount of acceptable bid  
 bond is 5% of total bid. You may state  
 "5% of bid" or a specific amount on  
 this line in words.
- (L) Amount of bond in figures
- (M) Brief Description of scope of work
- (N) Day of the month
- (O) Month
- (P) Year
- (Q) Name of Corporation
- (R) Raised Corporate Seal of Principal
- (S) Signature of President or Vice  
 President
- (T) Title of person signing
- (U) Raised Corporate Seal of Surety
- (V) Corporate Name of Surety
- (W) Signature of Attorney in Fact of the  
 Surety

NOTE: Dated, Power of Attorney with Raised  
 Surety Seal must accompany this bid  
 bond.

KNOW ALL MEN BY THESE PRESENTS, That we, the undersigned,  
 \_\_\_\_\_ (C) of \_\_\_\_\_ (D), \_\_\_\_\_ (E)  
 as Principal, and \_\_\_\_\_ (F) of \_\_\_\_\_ (G),  
 \_\_\_\_\_ (H), a corporation organized and existing under the laws  
 of the State of \_\_\_\_\_ (I) with its principal office in the City of  
 \_\_\_\_\_ (J), as Surety, are held and firmly bound unto The State  
 of West Virginia, as Oblige, in the penal sum of \_\_\_\_\_ (K)  
 (\$ \_\_\_\_\_ (L)) for the payment of which, well and truly to be made,  
 we jointly and severally bind ourselves, our heirs, administrators, executors,  
 successors and assigns.

The Condition of the above obligation is such that whereas the Principal  
 has submitted to the Purchasing Section of the Department of Administration  
 a certain bid or proposal, attached hereto and made a part hereof to enter into a  
 contract in writing for \_\_\_\_\_ (M)

**NOW THEREFORE.**

(a) If said bid shall be rejected, or  
 (b) If said bid shall be accepted and the Principal shall enter into a  
 contract in accordance with the bid or proposal attached hereto and shall furnish  
 any other bonds and insurance required by the bid or proposal, and shall in all  
 other respects perform the agreement created by the acceptance of said bid then  
 this obligation shall be null and void, otherwise this obligation shall remain in full  
 force and effect. It is expressly understood and agreed that the liability of the  
 Surety for any and all claims hereunder shall, in no event, exceed the penal  
 amount of this obligation as herein stated

The Surety for value received, hereby stipulates and agrees that the  
 obligations of said Surety and its bond shall be in no way impaired or affected by  
 any extension of time within which the Oblige may accept such bid: and said  
 Surety does hereby waive notice of any such extension.

IN WITNESS WHEREOF, Principal and Surety have hereunto set their  
 hands and seals, and such of them as are corporations have caused their corporate  
 seals to be affixed hereto and these presents to be signed by their proper officers,  
 this \_\_\_\_\_ (N) day of \_\_\_\_\_ (O), 20 \_\_\_\_\_ (P).

Principal Corporate Seal

(R)

Surety Corporate Seal

(U)

\_\_\_\_\_  
 (Name of Principal)  
 By \_\_\_\_\_  
 (Must be President or  
 Vice President)  
 \_\_\_\_\_  
 Title  
 \_\_\_\_\_  
 (Name of Surety)  
 \_\_\_\_\_  
 Attorney-in-Fact

**IMPORTANT** – Surety executing bonds must be licensed in West Virginia to  
 transact surety insurance. Raised Corporate Seals must be affixed and a Power of  
 Attorney must be attached.

Agency \_\_\_\_\_  
REQ.P.O# \_\_\_\_\_

**BID BOND**

KNOW ALL MEN BY THESE PRESENTS, That we, the undersigned, \_\_\_\_\_  
of \_\_\_\_\_, \_\_\_\_\_, as Principal, and \_\_\_\_\_  
of \_\_\_\_\_, \_\_\_\_\_, a corporation organized and existing under the laws of the State of \_\_\_\_\_  
with its principal office in the City of \_\_\_\_\_, as Surety, are held and firmly bound unto the State  
of West Virginia, as Obligee, in the penal sum of \_\_\_\_\_ (\$ \_\_\_\_\_) for the payment of which,  
well and truly to be made, we jointly and severally bind ourselves, our heirs, administrators, executors, successors and assigns.

The Condition of the above obligation is such that whereas the Principal has submitted to the Purchasing Section of the  
Department of Administration a certain bid or proposal, attached hereto and made a part hereof, to enter into a contract in writing for  
\_\_\_\_\_  
\_\_\_\_\_  
\_\_\_\_\_

**NOW THEREFORE,**

- (a) If said bid shall be rejected, or
- (b) If said bid shall be accepted and the Principal shall enter into a contract in accordance with the bid or proposal attached  
hereto and shall furnish any other bonds and insurance required by the bid or proposal, and shall in all other respects perform the  
agreement created by the acceptance of said bid, then this obligation shall be null and void, otherwise this obligation shall remain in full  
force and effect. It is expressly understood and agreed that the liability of the Surety for any and all claims hereunder shall, in no event,  
exceed the penal amount of this obligation as herein stated.

The Surety, for the value received, hereby stipulates and agrees that the obligations of said Surety and its bond shall be in no  
way impaired or affected by any extension of the time within which the Obligee may accept such bid, and said Surety does hereby  
waive notice of any such extension.

IN WITNESS WHEREOF, Principal and Surety have hereunto set their hands and seals, and such of them as are corporations  
have caused their corporate seals to be affixed hereunto and these presents to be signed by their proper officers, this  
\_\_\_\_\_ day of \_\_\_\_\_, 20\_\_\_\_\_.

Principal Corporate Seal

\_\_\_\_\_  
(Name of Principal)

By \_\_\_\_\_  
(Must be President or  
Vice President)

\_\_\_\_\_  
(Title)

Surety Corporate Seal

\_\_\_\_\_  
(Name of Surety)

\_\_\_\_\_  
Attorney-in-Fact

**IMPORTANT – Surety executing bonds must be licensed in West Virginia to transact surety insurance. Raised corporate seals  
must be affixed, a power of attorney must be attached.**



**LABOR AND MATERIAL PAYMENT BOND**

KNOW ALL MEN BY THESE PRESENTS:

That \_\_\_\_\_  
(Name, address or legal title of the Contractor)

as Principal, hereinafter called Contractor, and \_\_\_\_\_

\_\_\_\_\_ a corporation organized and existing under  
the laws of the State of \_\_\_\_\_, with its principal office in the City of \_\_\_\_\_

as Surety, hereinafter called Surety, are held firmly bound unto \_\_\_\_\_  
(Name, address or legal title of Owner)

as Obligee, hereinafter called Owner, for the use and benefit of claimants as herein below defined in the amount of  
\_\_\_\_\_ Dollars (\$ \_\_\_\_\_ ),  
for the payment whereof Principal and Surety bind themselves, their heirs, executors, administrators, successors and  
assigns, jointly and severally, firmly by these presents.

WHEREAS, Contractor has by written agreement dated \_\_\_\_\_

\_\_\_\_\_ entered into a contract with Owner for  
\_\_\_\_\_  
\_\_\_\_\_

in accordance with drawings and specifications prepared by \_\_\_\_\_  
\_\_\_\_\_

which contract is by reference made a part hereof, and is hereinafter referred to as the CONTRACT

NOW, THEREFORE, THE CONDITION OF THIS OBLIGATION is such that if Contractor shall, well and truly perform the  
contract, and shall pay off, satisfy and discharge all claims of subcontractors, labors, materialmen and all persons furnishing  
material or doing work pursuant to the CONTRACT and shall save Owner and its property harmless from any and all liability over  
and above the contract price thereof, between the owner and the Contractor, for all of such labor and material, and shall fully pay off  
and discharge and secure the release of any and all mechanics liens which may be placed upon said property by any such  
subcontractor, laborer or materialmen, then this obligation shall be null and void. Otherwise, it shall remain in full force and effect.

Signed and sealed this \* \_\_\_\_\_ day of \_\_\_\_\_

Principal Raised Corporate Seal \_\_\_\_\_ (Seal)  
(Contractor Name)

Surety Raised Corporate Seal \_\_\_\_\_ (Seal)  
(Must be President or Vice President)

\_\_\_\_\_  
(Title)

\_\_\_\_\_  
(Surety)

By \_\_\_\_\_ (Seal)

**NOTE:** Raised Corporate Seals are mandatory.  
Please attach Power of Attorney

**NOTE:** Applicable Section of attached acknowledge-  
ment must be completed and returned as part of  
the bond.

\* Power of Attorney must be certified on this date or later.

**ACKNOWLEDGEMENTS**

**Acknowledgement by Principal if individual or Partnership**

- 1. STATE OF \_\_\_\_\_
- 2. County of \_\_\_\_\_ to-wit:
- 3. I, \_\_\_\_\_, a Notary Public in and for the
- 4. county and state aforesaid, do hereby certify that \_\_\_\_\_ whose name is signed to the foregoing writing, has this day acknowledged the same before me in my said county.
- 5. Given under my hand this \_\_\_\_\_ day of \_\_\_\_\_ 20 \_\_\_\_\_.
- 6. Notary Seal
- 7. \_\_\_\_\_ (Notary Public)
- 8. My commission expires on the \_\_\_\_\_ day of \_\_\_\_\_ 20 \_\_\_\_\_.

**Acknowledgement by Principal if Corporation**

- 9. STATE OF \_\_\_\_\_
- 10. County of \_\_\_\_\_ to-wit:
- 11. I, \_\_\_\_\_, a Notary Public in and for the
- 12. county and state aforesaid, do hereby certify that \_\_\_\_\_
- 13. who as, \_\_\_\_\_ signed the foregoing writing for
- 14. \_\_\_\_\_ a corporation, has this day, in my said county, before me, acknowledged the said writing to be the act and deed of the said corporation.
- 15. Given under my hand this \_\_\_\_\_ day of \_\_\_\_\_ 20 \_\_\_\_\_.
- 16. Notary Seal
- 17. \_\_\_\_\_ (Notary Public)
- 18. My commission expires on the \_\_\_\_\_ day of \_\_\_\_\_ 20 \_\_\_\_\_.

**Acknowledgement by Surety**

- 19. STATE OF \_\_\_\_\_
- 20. County of \_\_\_\_\_ to-wit:
- 21. I, \_\_\_\_\_, a Notary Public in and for the
- 22. county and state aforesaid, do hereby certify that \_\_\_\_\_
- 23. who as, \_\_\_\_\_ signed the foregoing writing for
- 24. \_\_\_\_\_ a corporation, has this day, in my said county, before me, acknowledged the said writing to be the act and deed of the said corporation.
- 25. Given under my hand this \_\_\_\_\_ day of \_\_\_\_\_ 20 \_\_\_\_\_.
- 26. Notary Seal
- 27. \_\_\_\_\_ (Notary Public)
- 28. My commission expires on the \_\_\_\_\_ day of \_\_\_\_\_ 20 \_\_\_\_\_.

**Sufficiency in Form and Manner Of Execution Approved**

**Attorney General**

This \_\_\_\_\_ day of \_\_\_\_\_ 20 \_\_\_\_\_

By \_\_\_\_\_ (Assistant Attorney General)

PERFORMANCE BOND

KNOW ALL MEN BY THESE PRESENTS:

That \_\_\_\_\_ (Name, address or legal title of the Contractor)

as Principal, hereinafter called Contractor, and \_\_\_\_\_

\_\_\_\_\_ a corporation organized and existing under the laws of the State of \_\_\_\_\_, with its principal office in the City of \_\_\_\_\_

as Surety, hereinafter called Surety, are held firmly bound unto \_\_\_\_\_ (Name, address or legal title of Owner)

as Obligee, hereinafter called Owner, in the amount of \_\_\_\_\_

Dollars (\$ \_\_\_\_\_ ), for the payment whereof Contractor and Surety bind themselves, their heirs, executors, administrators, successors, and assigns, jointly and severally, firmly by these presents.

WHEREAS, Contractor has by written agreement dated \_\_\_\_\_ entered into a contract with Owner for \_\_\_\_\_

in accordance with drawings and specifications prepared by \_\_\_\_\_

which contract is by reference made a part hereof, and is hereinafter referred to as the CONTRACT

NOW, THEREFORE, THE CONDITION OF THIS OBLIGATION is such that if Contractor shall, promptly and faithfully Perform and CONTRACT, then this obligation shall be null and void, otherwise it shall remain in full force and effect.

The Surety hereby waives notice of any alteration or extension of time made by the Owner.

Whenever Contractor shall be, and declared by Owner to be in default under the CONTRACT, the Owner having performed Owner's obligations thereunder, the Surety may promptly remedy the default, or shall promptly:

- 1. Complete the CONTRACT in accordance with its terms and conditions, and
2. Shall save the Owner harmless from any claims, judgments, or liens arising from the Surety's failure to either remedy the default or to complete the CONTRACT in accordance with its terms and conditions in a timely manner.

No right of action shall accrue on this bond to or for the use of any person or corporation other than the Owner named herein or the successors of Owner.

Signed and sealed this \* \_\_\_\_\_ day of \_\_\_\_\_

Principal Raised Corporate Seal \_\_\_\_\_ (Seal) (Contractor Name)

Surety Raised Corporate Seal By \_\_\_\_\_ (Seal) (Must be President or Vice President)

\_\_\_\_\_ (Title)

\_\_\_\_\_ (Surety)

By \_\_\_\_\_ (Seal)

NOTE: Raised Corporate Seals are mandatory. Please attach Power of Attorney

NOTE: Applicable Section of attached acknowledgement must be completed and returned as part of the bond.

\* Power of Attorney must be certified on this date or later.

**Acknowledgement by Principal if Individual or Partnership**

- 1. STATE OF \_\_\_\_\_
- 2. County of \_\_\_\_\_ to-wit:
- 3. I, \_\_\_\_\_, a Notary Public in and for the
- 4. county and state aforesaid, do hereby certify that \_\_\_\_\_  
whose name is signed to the foregoing writing, has this day acknowledged the same before me in my said county.
- 5. Given under my hand this \_\_\_\_\_ day of \_\_\_\_\_ 20\_\_\_\_\_.
- 6. Notary Seal
- 7. \_\_\_\_\_  
(Notary Public)
- 8. My commission expires on the \_\_\_\_\_ day of \_\_\_\_\_ 20\_\_\_\_\_.

**Acknowledgement by Principal if Corporation**

- 9. STATE OF \_\_\_\_\_
- 10. County of \_\_\_\_\_ to-wit:
- 11. I, \_\_\_\_\_, a Notary Public in and for the
- 12. county and state aforesaid, do hereby certify that \_\_\_\_\_
- 13. who as, \_\_\_\_\_ signed the foregoing writing for
- 14. \_\_\_\_\_ a corporation,  
has this day, in my said county, before me, acknowledged the said writing to be the act and deed of the said corporation.
- 15. Given under my hand this \_\_\_\_\_ day of \_\_\_\_\_ 20\_\_\_\_\_.
- 16. Notary Seal
- 17. \_\_\_\_\_  
(Notary Public)
- 18. My commission expires on the \_\_\_\_\_ day of \_\_\_\_\_ 20\_\_\_\_\_.

**Acknowledgement by Surety**

- 19. STATE OF \_\_\_\_\_
- 20. County of \_\_\_\_\_ to-wit:
- 21. I, \_\_\_\_\_, a Notary Public in and for the
- 22. county and state aforesaid, do hereby certify that \_\_\_\_\_
- 23. who as, \_\_\_\_\_ signed the foregoing writing for
- 24. \_\_\_\_\_ a corporation,  
has this day, in my said county, before me, acknowledged the said writing to be the act and deed of the said corporation.
- 25. Given under my hand this \_\_\_\_\_ day of \_\_\_\_\_ 20\_\_\_\_\_.
- 26. Notary Seal
- 27. \_\_\_\_\_  
(Notary Public)
- 28. My commission expires on the \_\_\_\_\_ day of \_\_\_\_\_ 20\_\_\_\_\_.

**Sufficiency in Form and Manner  
Of Execution Approved**

**Attorney General**

This \_\_\_\_\_ day of \_\_\_\_\_ 20\_\_\_\_\_

By \_\_\_\_\_  
(Assistant Attorney General)

---

## ACKNOWLEDGEMENT PREPARATION INSTRUCTIONS

---

1. IF PRINCIPAL IS AN INDIVIDUAL OR PARTNERSHIP, HAVE NOTARY COMPLETE LINES (1) through (8).
2. IF PRINCIPAL IS A CORPORATION, HAVE NOTARY COMPLETE LINES (9) through (18).
3. SURETY MUST HAVE NOTARY COMPLETE LINES (19) through (28).
4. **Notaries must:**

---

### ACKNOWLEDGEMENT BY PRINCIPAL IF INDIVIDUAL OR PARTNERSHIP

---

1. Enter name of State.
2. Enter name of County.
3. Enter name of Notary Public witnessing transactions.
4. Enter name of principal covered by bond if individual or partnership. Notary enters date bond was witnessed.
5. Must be the same as or later than signature date.
6. Affix Notary Seal.
7. Notary affixes his/her signature.
8. Notary enters commission date.

---

### ACKNOWLEDGEMENT BY PRINCIPAL IF CORPORATION

---

9. Enter name of State.
10. Enter name of County.
11. Enter name of Notary Public witnessing transactions.
12. Enter name of Corporate Officer signing bond. (Must be President or Vice President.)
13. Enter Title of Corporate Officer signing bond.
14. Enter name of Company or Corporation.
15. Notary enters date bond was witnessed. Must be the same as or later than signature date.
16. Affix Notary Seal.
17. Notary affixes his/her signature.
18. Notary enters commission date.

---

### ACKNOWLEDGEMENT BY SURETY

---

19. Enter name of State.
20. Enter name of County.
21. Enter name of Notary Public witnessing transactions.
22. Enter name of person having power of attorney to bind Surety Company.
23. Enter Title of person binding Surety Company.
24. Enter name of Insurance Company (Surety).
25. Notary enters date bond was witnessed. Must be the same as or later than signature date.
26. Affix Notary Seal.
27. Notary affixes his/her signature.
28. Notary enters commission date.

---

### POWER OF ATTORNEY INSTRUCTIONS

---

Power of attorney for surety must be attached showing that it was in full force and effect on signature date indicated on the face of the bond. A raised corporate seal must also be affixed to the Power of Attorney form.

- a. Name of attorney in fact must be listed (if attorney is a non-resident, bond must be countersigned by West Virginia resident agent).
- b. Power of Attorney may not exceed imposed limitations.
- c. Certificate date, the signature date of bond must be entered.
- d. Signature of authorizing official must be affixed. (Signature may be facsimile).
- e. **Raised seal must be affixed.**

DEFK 8220 PRE-BID SIGN IN SHEET

COMPANY NAME      COMPANY POC      PHONE NUMBER      EMAIL

Glem Company      Ren Hoffman      304-342-2721      scbrowning@wvdot.net  
UPON Construction Co. Inc.      JOE TICKER <sup>TWA</sup> DAVIS      PH. 304-744-4627       
Babcock Fence Company      Mike Babcock      FAX 304-744-4626      mikebabcock@verizon.net  
T.A. SMITH Exco.      Larry Merrill      P-740 896 2371       
WARREN Co.      Harold Butler      304-885-9252      harold.g.butler@warrenco.wv.us