



State of West Virginia
 Department of Administration
 Purchasing Division
 2019 Washington Street East
 Post Office Box 50130
 Charleston, WV 25305-0130

Request for Quotation

RFQ NUMBER
DEFK8030

PAGE
1

ADDRESS CORRESPONDENCE TO ATTENTION OF:
JOHN ABBOTT
304-558-2544

VENDOR

RFQ COPY
 TYPE NAME/ADDRESS HERE

SHIP TO

DIV ENGINEERING & FACILITIES
NATIONAL GUARD ARMORY
U. S. RT. 19, SOUTH

WESTON, WV
26452 **341-6368**

DATE PRINTED 08/20/2007	TERMS OF SALE	SHIP VIA	F.O.B.	FREIGHT TERMS
-----------------------------------	---------------	----------	--------	---------------

BID OPENING DATE: **08/30/2007** BID OPENING TIME **01:30PM**

LINE	QUANTITY	UOP	CAT NO.	ITEM NUMBER	UNIT PRICE	AMOUNT
				ADDENDUM #01		
				THIS ADDENDUM IS ISSUED TO CLARIFY, MODIFY, ADD TO, AND/OR DELETE REQUIREMENTS OF THE ORIGINAL REQUEST FOR QUOTATION.		
				ATTACHMENTS: 1. ADDENDUM #01 2. PRE-BID SIGN-IN SHEET		

SEE REVERSE SIDE FOR TERMS AND CONDITIONS

SIGNATURE	TELEPHONE	DATE
TITLE	FEIN	ADDRESS CHANGES TO BE NOTED ABOVE

WHEN RESPONDING TO RFQ, INSERT NAME AND ADDRESS IN SPACE ABOVE LABELED 'VENDOR'

**GENERAL TERMS & CONDITIONS
REQUEST FOR QUOTATION (RFQ) AND REQUEST FOR PROPOSAL (RFP)**

1. Awards will be made in the best interest of the State of West Virginia.
2. The State may accept or reject in part, or in whole, any bid.
3. All quotations are governed by the *West Virginia Code* and the *Legislative Rules* of the Purchasing Division.
4. Prior to any award, the apparent successful vendor must be properly registered with the Purchasing Division and have paid the required \$125.00 registration fee.
5. All services performed or goods delivered under State Purchase Orders/Contracts are to be continued for the term of the Purchase Order/Contract, contingent upon funds being appropriated by the Legislature or otherwise being made available. In the event funds are not appropriated or otherwise available for these services or goods, this Purchase Order/Contract becomes void and of no effect after June 30.
6. Payment may only be made after the delivery and acceptance of goods or services.
7. Interest may be paid for late payment in accordance with the *West Virginia Code*.
8. Vendor preference will be granted upon written request in accordance with the *West Virginia Code*.
9. The State of West Virginia is exempt from federal and state taxes and will not pay or reimburse such taxes.
10. The Director of Purchasing may cancel any Purchase Order/Contract upon 30 days written notice to the seller.
11. The laws of the State of West Virginia and the *Legislative Rules* of the Purchasing Division shall govern all rights and duties under the Contract, including without limitation the validity of this Purchase Order/Contract.
12. Any reference to automatic renewal is hereby deleted. The Contract may be renewed only upon mutual written agreement of the parties.
13. **BANKRUPTCY:** In the event the vendor/contractor files for bankruptcy protection, this contract is automatically null and void, and is terminated without further order.
14. **HIPAA Business Associate Addendum -** The West Virginia State Government HIPAA Business Associate Addendum (BAA), approved by the Attorney General, and available online at the Purchasing Division's web site (<http://www.state.wv.us/admin/purchase/vrc/hipaa.htm>) is hereby made part of the agreement. Provided that, the Agency meets the definition of a Covered Entity (45 CFR §160.103) and will be disclosing Protected Health Information (45 CFR §160.103) to the vendor.

INSTRUCTIONS TO BIDDERS

1. Use the quotation forms provided by the Purchasing Division.
2. **SPECIFICATIONS:** Items offered must be in compliance with the specifications. Any deviation from the specifications must be clearly indicated by the bidder. Alternates offered by the bidder as **EQUAL** to the specifications must be clearly defined. A bidder offering an alternate should attach complete specifications and literature to the bid. The Purchasing Division may waive minor deviations to specifications.
3. Complete all sections of the quotation form.
4. Unit prices shall prevail in cases of discrepancy.
5. All quotations are considered F.O.B. destination unless alternate shipping terms are clearly identified in the quotation.
6. **BID SUBMISSION:** All quotations must be delivered by the bidder to the office listed below prior to the date and time of the bid opening. Failure of the bidder to deliver the quotations on time will result in bid disqualifications.

SIGNED BID TO:

Department of Administration
Purchasing Division
2019 Washington Street East
Post Office Box 50130
Charleston, WV 25305-0130



OFFICE OF THE ADJUTANT GENERAL
DIVISION OF ENGINEERING AND FACILITIES

1707 COONSKIN DRIVE
CHARLESTON, WEST VIRGINIA 25311-1099
(304) 561-6333

Allen E. Tackett
Major General, WVARNG
The Adjutant General

Michael J. Beckner
Captain, WVARNG
Armory Facilities Manager

August 17, 2007

DEFK8030

ADDENDUM #1

1. Change 18" OC gutter attachment from west to east wall. Applies to upper and lower roofs.
2. 7" continuous gutter is to be unflanged to accept Sure-Seal Edge Drip Detail
3. Install Carlisle Sure-Seal Drip Edge per Detail FB-1-B (for FleeceBack 115 membrane) or Detail PS-1-A (for standard .060 Std. FR membrane) at all gutter locations to meet 90 MPH Wind Warranty requirements. Both details enclosed for your reference.
4. Corrected Tapered Iso drawing enclosed to reflect offset wall and two (2) small lower roof areas not shown on original drawings

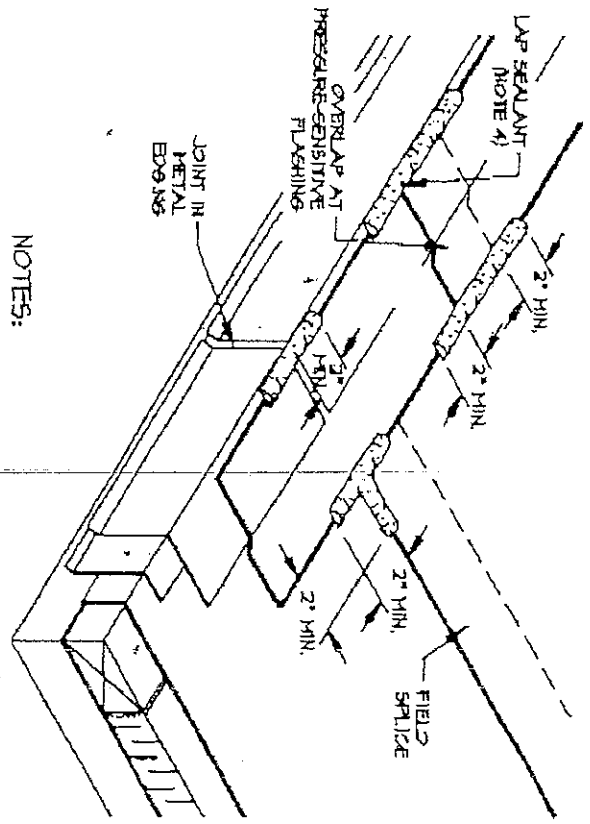
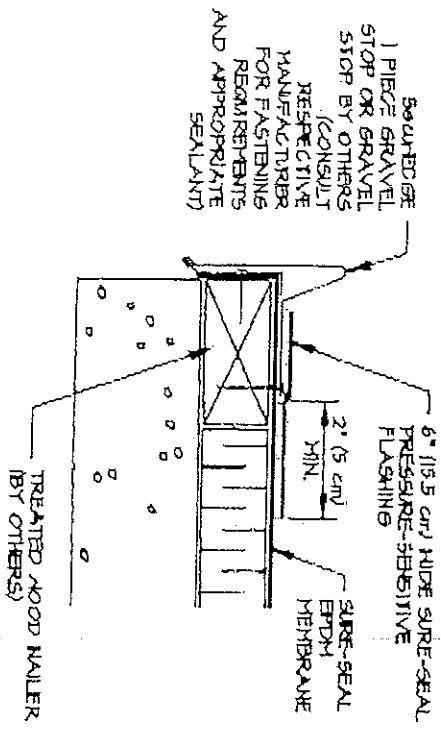
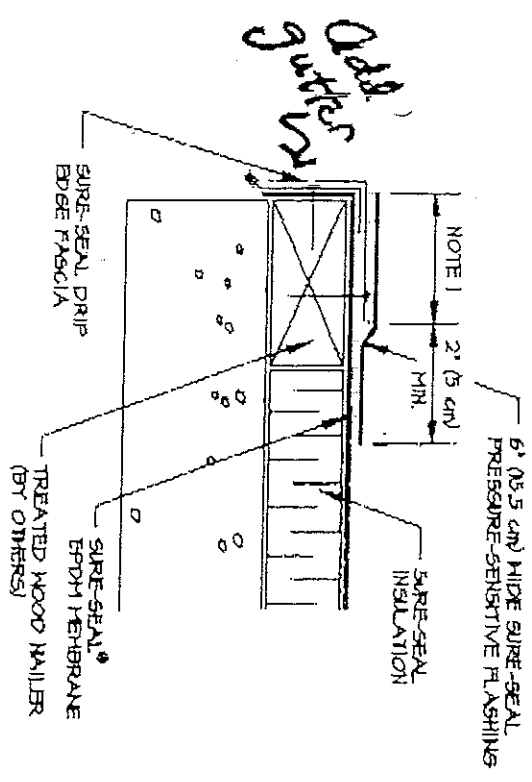

PS-1-A (OPTION #2) DETAIL NOT FOR USE WITH DESIGN "C"

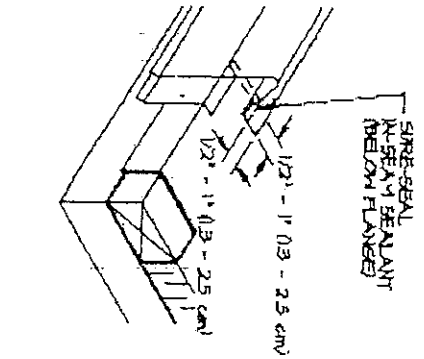

NOTES:

1. DECK FLANGE MUST BE TOTALLY COVERED BY PRESSURE-SENSITIVE FLASHING WITH MINIMUM 2" (5 cm) COVERAGE PAST NAIL HEADS.
2. TO REMOVE FINISHING OILS, SCRUB METAL FLANGE WITH WARM SOAPY WATER AND RINSE WITH CLEAN WATER ALLOW TO DRY PRIOR TO APPLYING PRIMER.
3. APPLY SURE-SEAL-PRIMER TO METAL FLANGE AND EPDM MEMBRANE SURFACE PRIOR TO INSTALLING PRESSURE-SENSITIVE FLASHING.
4. LAP SEALANT MUST BE APPLIED AT FLASHING AND TAPE OVERLAPS AND INTERSECTIONS WITH FIELD SEAMS OR JOINTS IN METAL EDGING.
5. REFER TO APPLICABLE CARLISLE METAL EDGING INSTALLATION INSTRUCTION MANUAL FOR STEP-BY-STEP INSTALLATION PROCEDURES.

PS-1-A (OPTION # 2)

METAL EDGE TERMINATION WITH PRESSURE-SENSITIVE FLASHING



© 2000 CARLISLE SYSTEMS INCORPORATED

Detail

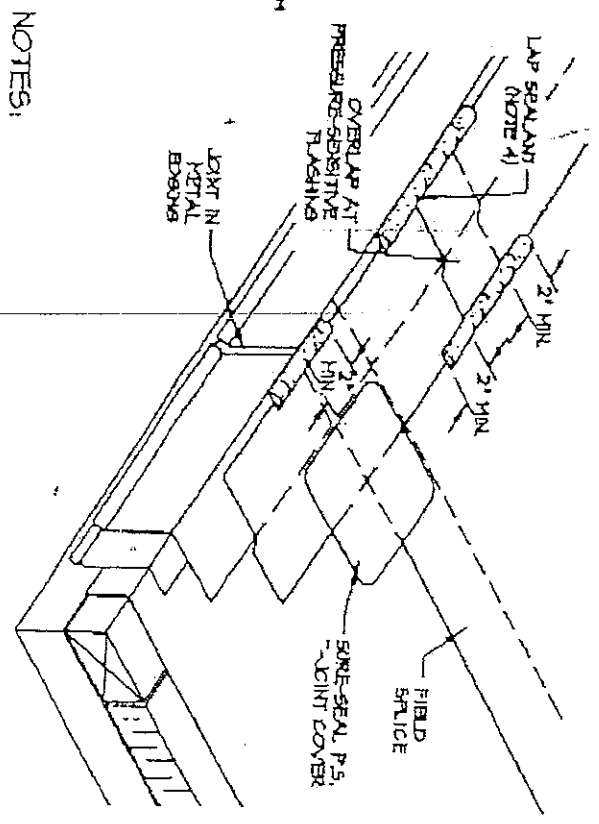
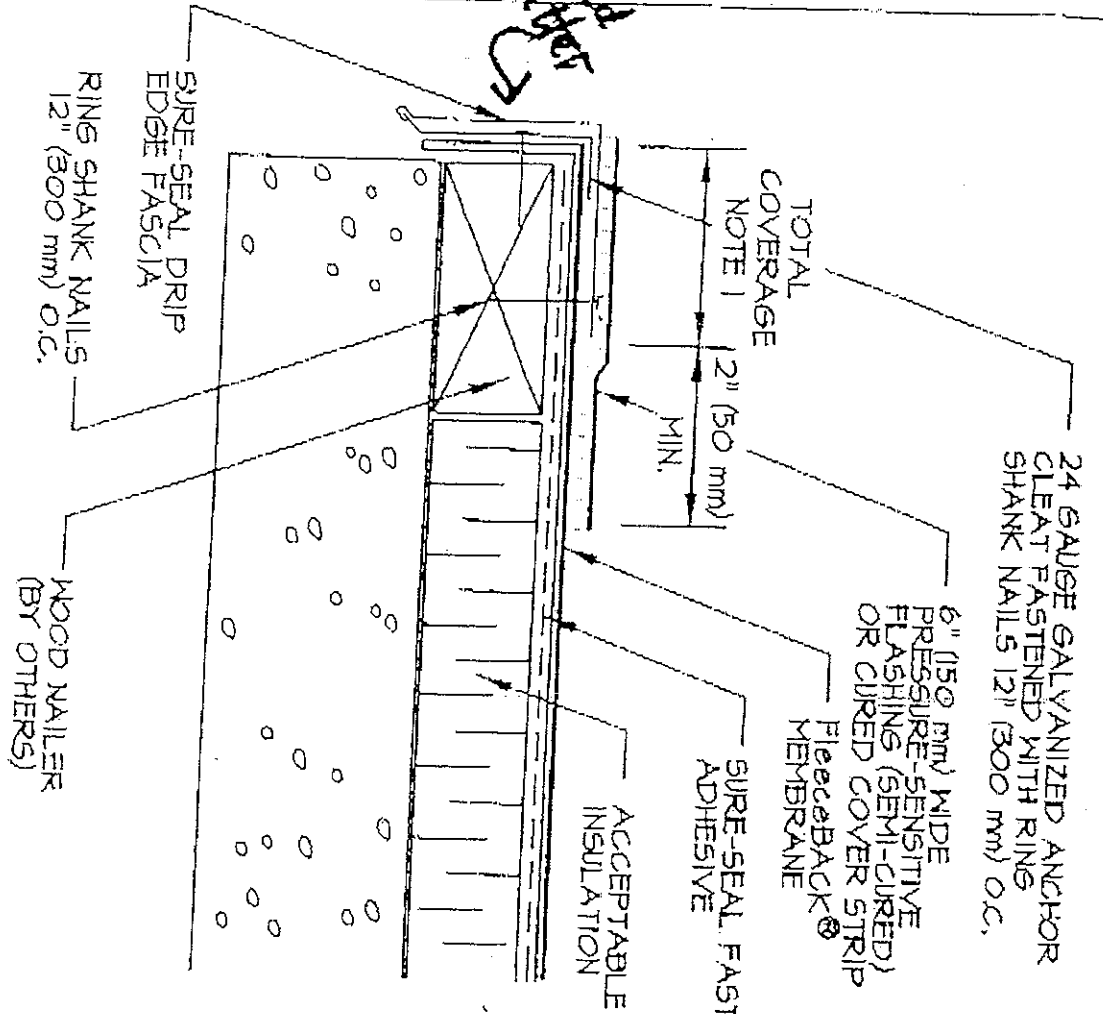

NOTES:

1. DECK FLANGE MUST BE TOTALLY COVERED BY PRESSURE-SENSITIVE FLASHING WITH MINIMUM 2" (50 mm) COVERAGE PAST NAIL HEADS.
2. TO REMOVE FINISHING OILS, SCRUB METAL FLANGE WITH WARM SOAPY WATER AND RINSE WITH CLEAN WATER; ALLOW TO DRY PRIOR TO APPLYING PRIMER.
3. APPLY SURE-SEAL PRIMER TO METAL FLANGE AND EPDM MEMBRANE SURFACE PRIOR TO INSTALLING PRESSURE-SENSITIVE FLASHING.
4. LAP SEALANT MUST BE APPLIED AT FLASHING OVERLAPS, AND INTERSECTIONS WITH JOINTS IN METAL EDGING.

FB-1-B

SURE-SEAL® DRIP EDGE / PRESSURE-SENSITIVE FLASHING

CARLISLE

Carlisle SynTec Incorporated

© 2004 Carlisle SynTec Incorporated

NORTH COAST COMMERCIAL ROOFING

Project: National Guard Armory

Job Number: F07-6538

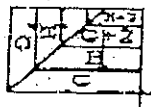
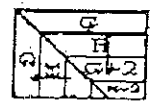
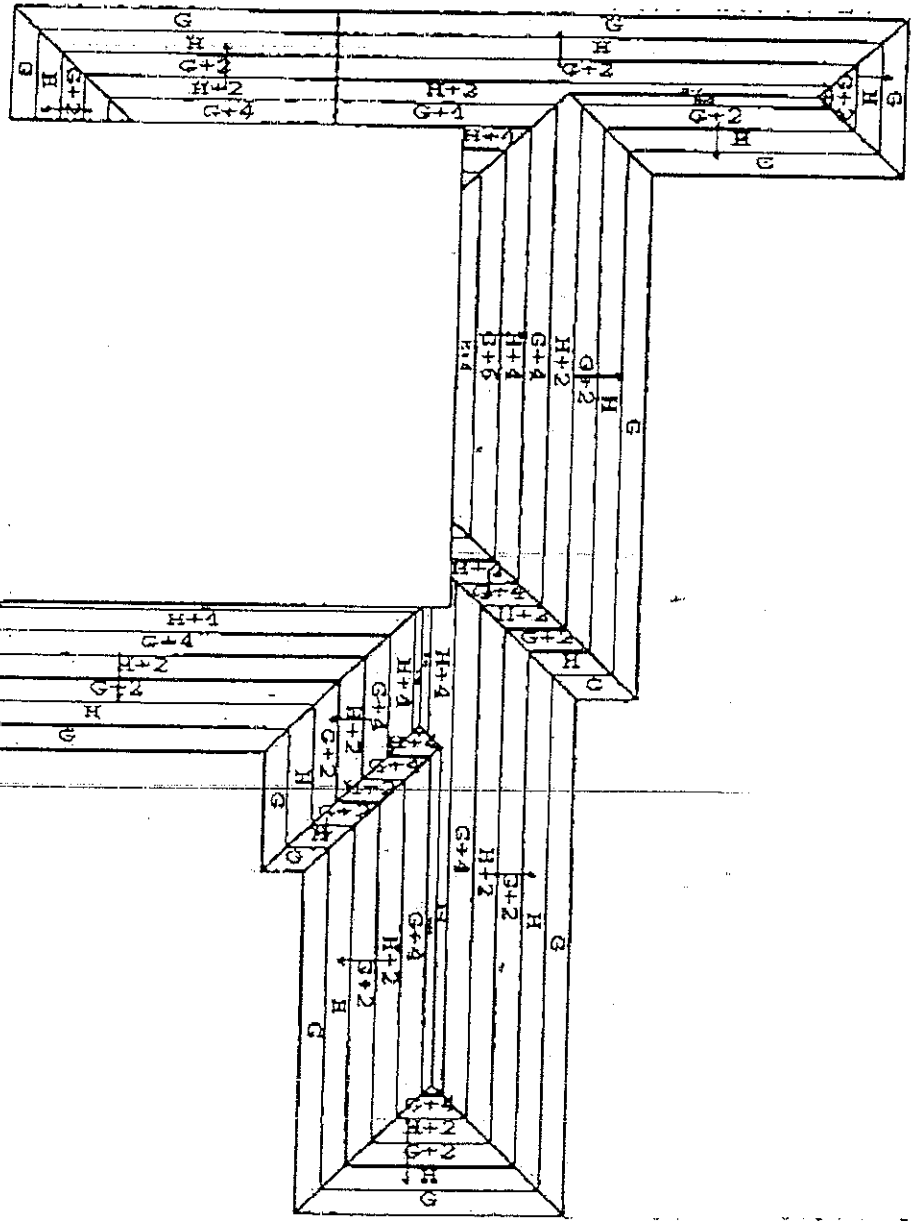

Pre-Bid Conference
SIGN IN SHEET

[Please Print]

Request for Proposal No: DEFK 8030 Date: 8/14/07

<u>Firm & Representative Name</u>	<u>Mailing Address</u>	<u>Telephone & FAX Numbers</u>
1. <u>Ed Smith</u> <u>North Coast RB.</u>	<u>618 5th St W.</u> <u>Huntington WV 25701</u>	T: <u>304-523-5530</u> F: <u>24-523-5528</u>
2. <u>Ken HANSON</u> <u>TRI-STATE ROOFING & SM</u>	<u>P.O. BOX 892</u> <u>MORGANTOWN, WV 26507-0892</u>	T: <u>304-328-5244</u> F: <u>304-328-5248</u>
3. <u>Gene Ochap</u> <u>N.F. Mansueti & Sons Inc</u>	<u>2nd & Wood Streets</u> <u>Martins Ferry Ohio 43935</u>	T: <u>740-633-7320</u> F: <u>740-633-7322</u>
4. <u>Jeremiah Robinson</u> <u>Frye Roofing, Inc.</u>	<u>2000 Princeton Ave</u> <u>Bluefield, WV 24701</u>	T: <u>(304)327-5314</u> F: <u>(304)325-3700</u>
5. <u>Butch Runion</u> <u>S.M. Kiser & Sons</u>	<u>1114 Speedway Ave.</u> <u>Fairmont, WV 26554</u>	T: <u>304-366-4131</u> F: <u>304-366-4192</u>
6. <u>Stan Golczyca</u> <u>KALKREUTH Roofing</u>	<u>41-410th Street</u> <u>Wheeling W.V 26003</u>	T: <u>304-232-8540</u> F: <u>304-232-8552</u>
7. <u>SHANE ROSS</u> <u>BOGGS ROOFING</u>	<u>PO Box 7455</u> <u>Huntington, WV 25776</u>	T: <u>304-429-4233</u> F: <u>304-429-2811</u>
8. <u>DEF</u> <u>Charlie Mitchell</u>	<u>1707 Coopers Dr.</u> <u>Clus, WV 25311</u>	T: <u>561-6337</u> F: <u>561-6344</u>
9. _____	_____	T: _____ F: _____
10. _____	_____	T: _____ F: _____

Please print or write legibly. The fax number is essential to contact the attendees in a timely manner.