



State of West Virginia
 Department of Administration
 Purchasing Division
 2019 Washington Street East
 Post Office Box 50130
 Charleston, WV 25305-0130

Request for Quotation

RFQ NUMBER
GSD076433

PAGE
1

ADDRESS CORRESPONDENCE TO ATTENTION OF
KRISTA FERRELL 304-558-2596

RFQ COPY

TYPE NAME/ADDRESS HERE

VENDOR

SHIP TO

DEPARTMENT OF ADMINISTRATION
 GENERAL SERVICES DIVISION
 BUILDING 1
 1900 KANAWHA BOULEVARD, EAST
 CHARLESTON, WV
 25305 304-558-3517

DATE PRINTED 05/23/2007	TERMS OF SALE	SHIP VIA	FOB	FREIGHT TERMS
BID OPENING DATE: 06/06/2007		BID OPENING TIME 01:30PM		

LINE	QUANTITY	UOP	CAT NO.	ITEM NUMBER	UNIT PRICE	AMOUNT
ADDENDUM NO. 1						
THIS ADDENDUM IS ISSUED TO ANSWER QUESTIONS RAISED DURING THE MANDATORY PRE-BID MEETING, THE SITE VISIT, AND THOSE QUESTIONS SUBMITTED PRIOR TO THE MAY 21, 2007 DEADLINE PER THE ATTACHED.						
BID OPENING DATE IS EXTENDED TO: 06/06/2007						
BID OPENING TIME REMAINS: 1:30 PM						
***** END ADDENDUM NO. 1 *****						
0001	1	JB		936-10		
FAN COIL AND DUCT CLEANING, MAIN CAPITOL, BLDG#1						
***** THIS IS THE END OF RFQ GSD076433 ***** TOTAL:						

SEE REVERSE SIDE FOR TERMS AND CONDITIONS

SIGNATURE		TELEPHONE	DATE
TITLE	FEIN	ADDRESS CHANGES TO BE NOTED ABOVE	

WHEN RESPONDING TO RFQ, INSERT NAME AND ADDRESS IN SPACE ABOVE LABELED 'VENDOR'

**GENERAL TERMS & CONDITIONS
REQUEST FOR QUOTATION (RFQ) AND REQUEST FOR PROPOSAL (RFP)**

1. Awards will be made in the best interest of the State of West Virginia.
2. The State may accept or reject in part, or in whole, any bid.
3. All quotations are governed by the *West Virginia Code* and the *Legislative Rules* of the Purchasing Division.
4. Prior to any award, the apparent successful vendor must be properly registered with the Purchasing Division and have paid the required \$125.00 registration fee.
5. All services performed or goods delivered under State Purchase Orders/Contracts are to be continued for the term of the Purchase Order/Contract, contingent upon funds being appropriated by the Legislature or otherwise being made available. In the event funds are not appropriated or otherwise available for these services or goods, this Purchase Order/Contract becomes void and of no effect after June 30.
6. Payment may only be made after the delivery and acceptance of goods or services.
7. Interest may be paid for late payment in accordance with the *West Virginia Code*.
8. Vendor preference will be granted upon written request in accordance with the *West Virginia Code*.
9. The State of West Virginia is exempt from federal and state taxes and will not pay or reimburse such taxes.
10. The Director of Purchasing may cancel any Purchase Order/Contract upon 30 days written notice to the seller.
11. The laws of the State of West Virginia and the *Legislative Rules* of the Purchasing Division shall govern all rights and duties under the Contract, including without limitation the validity of this Purchase Order/Contract.
12. Any reference to automatic renewal is hereby deleted. The Contract may be renewed only upon mutual written agreement of the parties.
13. **BANKRUPTCY:** In the event the vendor/contractor files for bankruptcy protection, this contract is automatically null and void, and is terminated without further order.
14. **HIPAA Business Associate Addendum** - The West Virginia State Government HIPAA Business Associate Addendum (BAA), approved by the Attorney General, and available online at the Purchasing Division's web site (<http://www.state.wv.us/admin/purchase/vrc/hipaa.htm>) is hereby made part of the agreement. Provided that, the Agency meets the definition of a Covered Entity (45 CFR §160.103) and will be disclosing Protected Health Information (45 CFR §160.103) to the vendor.

INSTRUCTIONS TO BIDDERS

1. Use the quotation forms provided by the Purchasing Division.
2. **SPECIFICATIONS:** Items offered must be in compliance with the specifications. Any deviation from the specifications must be clearly indicated by the bidder. Alternates offered by the bidder as **EQUAL** to the specifications must be clearly defined. A bidder offering an alternate should attach complete specifications and literature to the bid. The Purchasing Division may waive minor deviations to specifications.
3. Complete all sections of the quotation form.
4. Unit prices shall prevail in cases of discrepancy.
5. All quotations are considered F.O.B. destination unless alternate shipping terms are clearly identified in the quotation.
6. **BID SUBMISSION:** All quotations must be delivered by the bidder to the office listed below prior to the date and time of the bid opening. Failure of the bidder to deliver the quotations on time will result in bid disqualifications.

SIGNED BID TO:

Department of Administration
Purchasing Division
2019 Washington Street East
Post Office Box 50130
Charleston, WV 25305-0130

ADDENDUM NO. 1
GSD076433
ANSWERS TO QUESTIONS FROM PRE-BID
MEETING/TECHNICAL QUESTIONS

- 1.) **Clarification:** This project includes both the cleaning and sanitizing of the ductwork and associated units.
- 2.) **Q. Will linear feet of the duct be provided?**
A. See attached drawing for layout. Linear feet not available.
- 3.) **Is the ductwork lined?**
A. No.
- 4.) **What do you consider clean? This is a broad concept.**
A. Most units have front access. The Whalen units are set up a little different, but you should be able to access everything easily. GSD will provide the successful vendor with new filters to install. Vendor will discard the old filters.
- 5.) **Clarification:** The drain pans should be 18 gauge galvanized sheet metal. Slope pan bottoms to drain.
- 6.) **Addition for Clarification:** Please add cut sheets for Whalen Units to the specifications.
- 7.) **Clarification:** Please note the two ceiling mounted fan coil units on the west soffit of the Government Organization Committee Room (Room No. 215)
- 8.) **Addition for Clarification:** Please add the attached floor plans to the specifications.

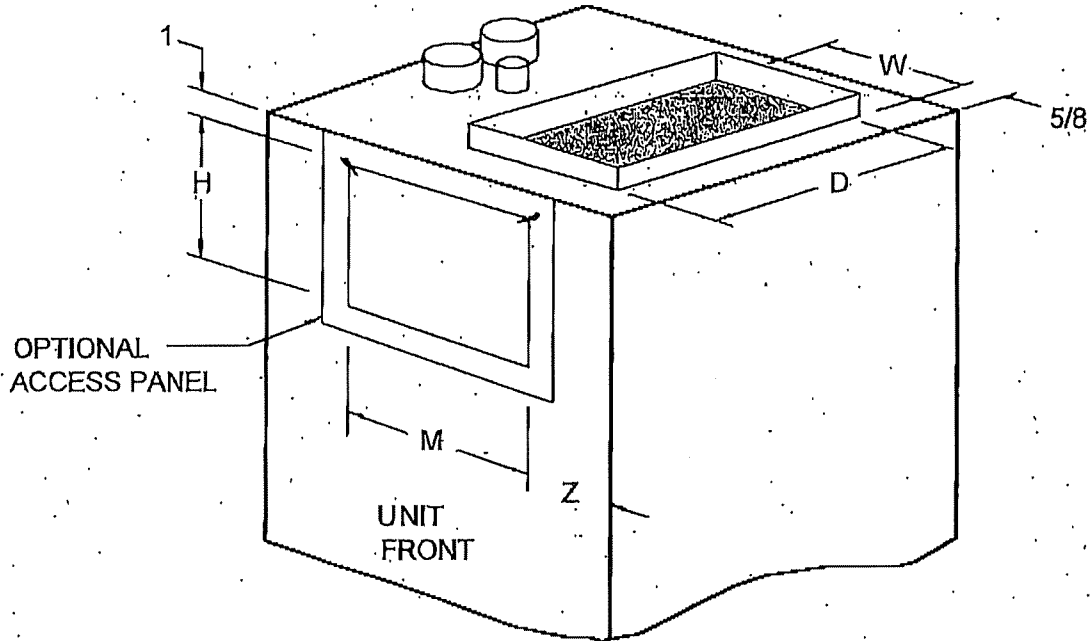

Notes:

1. See unit schedule for type of discharge arrangement.
2. Access panel is fabricated of aluminum and finished in white baked enamel.
3. Access panel is shipped loose, for installation after the drywall installation is complete.
4. Dimensions apply to standard height units only, with access panel on front or back of unit.

UNIT CFM	W	D	M	H	Z
200	6	12	10	8	1
300	6	12	10	8	1
400	8	12	10	8	3
500	8	12	10	8	3
600 FRONT	10	14	8	10	1
600 REAR	10	14	6	10	1
800 FRONT	10	14	8	10	1
800 REAR	10	14	6	10	1

All dimensions in inches.

RISER HEAT-EXCHANGER VERTICAL FAN-COIL UNITS

THE WHALEN COMPANY
EASTON, MARYLAND

ACCESS PANEL FOR UNITS WITH TYPE V
DUCTED DISCHARGE

DRAWING NUMBER 112A

SEPTEMBER 1989

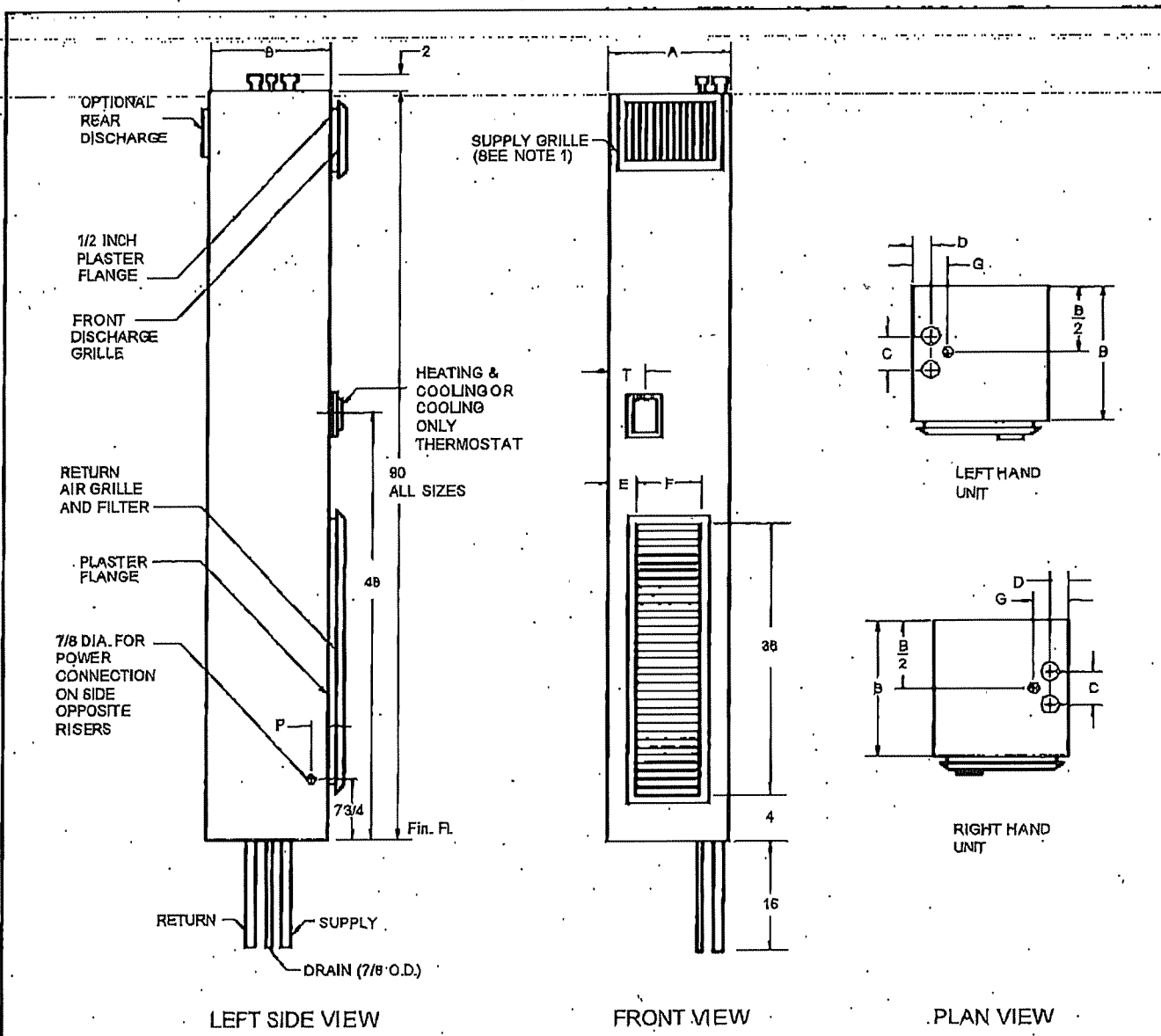

NOTES:

1. See drawing number 111 for supply grille or register options. The return air grille is always on the front of the unit.
2. Cabinet is continuous galvanized steel, suitable for direct application of "drywall" plasterboard.
3. Return air grille is extruded aluminum.
4. Supply, return and drain risers are copper.
5. Fan motor is 115 volt, 60 cycle, single phase.
6. Unless otherwise noted, the fan motor runs continuously on either high or low speed.

MODEL	NOM. CFM	A	B	C	D	E	F	G	P	T	MINIMUM SLEEVE SIZE
W202F	200	12	14	2 1/2	1 1/2	2	8	2 3/4	2 1/2	3	3 1/2 X 5
W302F	300	12	14	2 1/2	1 1/2	2	8	2 3/4	2 1/2	3	3 1/2 X 5
W302XF	300	14	14	4	2 3/4	2	10	4 1/2	3	4	4 1/2 X 8
W402F	400	18	18	4	2 3/4	3	10	4 1/2	3	4	4 1/2 X 8
W502F	500	18	18	4	2 3/4	3	10	4 1/2	3	4	4 1/2 X 8
W602F	600	18	18	4	2 3/4	3	12	4 1/2	3	6	4 1/2 X 8
W802F	800	18	16	4	2 3/4	3	12	4 1/2	3	6	8 X 10

All dimensions in inches.

RISER HEAT-EXCHANGER VERTICAL FAN-COIL UNITS

THE WHALEN COMPANY
EASTON, MARYLAND

2-PIPE HEATING/COOLING UNITS
OR 2-PIPE COOLING ONLY UNITS
WITH FACE & BYPASS DAMPER CONTROL

DRAWING NUMBER 102D

MARCH 1986

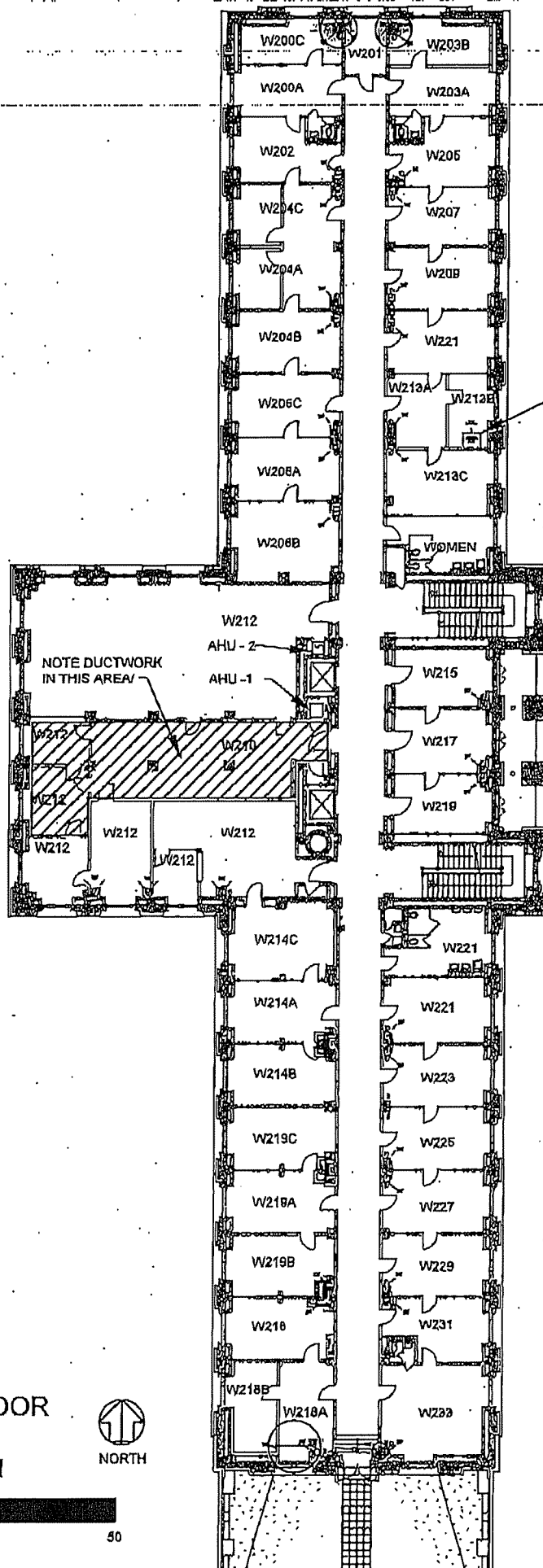

NOTE: CEILING MTD. FAN COIL UNIT.

NOTE DUCTWORK IN THIS AREA/

SECOND FLOOR WEST WING FLOOR PLAN

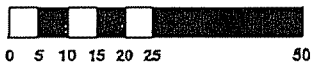

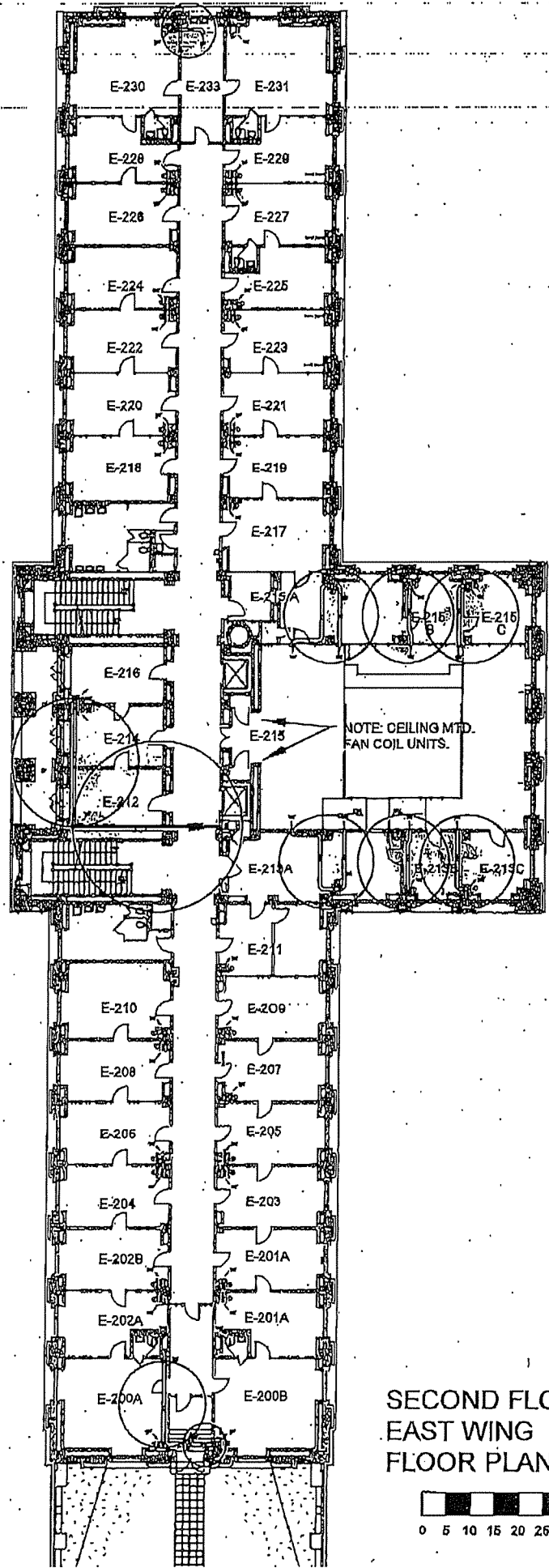

SECOND FLOOR
EAST WING
FLOOR PLAN

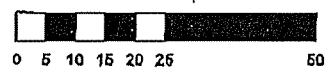

PRE-BID CONFERENCE
SIGN IN SHEET

page 1

Request for Quotation Number: GSD076433

Date: May 17, 2007 @ 10:00am

PLEASE PRINT LEGIBLY. THIS INFORMATION IS ESSENTIAL TO CONTACT THE ATTENDEES IN A TIMELY MANNER. FAILURE TO DO SO MAY RESULT IN DELAYS IN YOUR COMPANY GETTING IMPORTANT BID INFORMATION.

Firm Name:	<u>Indoor Air Tech</u>
Firm Address:	<u>33 W MAIN ST ROCHESTER, N.Y. 14564</u>
Representative Attending:	<u>Edward Hernandez</u>
Phone Number:	<u>(585) 924-2010</u>
Fax Number:	<u>(585) 924-2135</u>
Email Address:	<u>edward@indoorairtechnologies.com</u>

Firm Name:	<u>STEVE E. LUKER CLEANER</u>
Firm Address:	<u>619 E. MARLE AVE. JOHNSON CITY, TN 37601</u>
Representative Attending:	<u>STEVE MORAN</u>
Phone Number:	<u>423-926-1151</u>
Fax Number:	<u>423-926-5938</u>
Email Address:	<u>STEVE@E.LUKERCLEANER.COM</u>

Firm Name:	<u>AMERICAN CLEAN AIR</u>
Firm Address:	<u>3602 E. 7TH STREET STE 2 PARKERSBURG, WV 26104</u>
Representative Attending:	<u>RICK RUSSELL</u>
Phone Number:	<u>304 485-6233</u>
Fax Number:	<u>304 485-6234</u>
Email Address:	<u>ricker@dmcleanair.com</u>

Firm Name:	<u>H. E. Neumann Company</u>
Firm Address:	<u>1410 6th Avenue Charleston, WV 25312</u>
Representative Attending:	<u>John Jennings</u>
Phone Number:	<u>(304) 345-5580</u>
Fax Number:	<u>(304) 345-5543</u>
Email Address:	<u>jjennings@heneumann.com</u>

Firm Name:	
Firm Address:	
Representative Attending:	<u>Krista Ferrell/Purchasing</u>
Phone Number:	<u>558-2596</u>
Fax Number:	
Email Address:	

Firm Name:	<u>Robert Krause</u>
Firm Address:	<u>WV. GSD</u>
Representative Attending:	<u>SUSIE TEE/GSD</u>
Phone Number:	<u>558-0250</u>
Fax Number:	
Email Address:	