



State of West Virginia
 Department of Administration
 Purchasing Division
 2019 Washington Street East
 Post Office Box 50130
 Charleston, WV 25305-0130

Request for Quotation

RFQ NUMBER
COR61340

PAGE
1

ADDRESS CORRESPONDENCE TO ATTENTION OF
JOHN ABBOTT 304-558-2544

VENDOR

RFQ COPY
 TYPE NAME/ADDRESS HERE

SHIP TO

DIVISION OF CORRECTIONS
 617 LEON SULLIVAN WAY
 CHARLESTON, WV
 25301 304-558-8045

DATE PRINTED	TERMS OF SALE	SHIP VIA	F.O.B.	FREIGHT TERMS
02/22/2007				

BID OPENING DATE: 03/21/2007 BID OPENING TIME 01:30PM

LINE	QUANTITY	UOP	CAT. NO	ITEM NUMBER	UNIT PRICE	AMOUNT
0001	1	LS		031-06		
<p style="text-align: center;">REQUEST FOR QUOTATION</p> <p>THE PURCHASING DIVISION IS SOLICITING BIDS FOR THE DIVISION OF CORRECTIONS TO PROVIDE THE INSTALLATION OF HEATING AND COOLING UNITS; AND THE REMOVAL AND DISPOSAL OF THE OLD UNITS.</p> <p>MANDATORY ON-SITE PRE-BID: 03/07/2007; 2:00 PM. PRE-REGISTRATION IS REQUIRED BY CONTACTING TIM WHITTINGTON AT (304) 442-7214; BY 3/5/2007.</p> <p>ATTACHMENTS: 1. SPECIFICATIONS 2. AFFIDAVIT</p> <p>HEATING/COOLING UNIT INSTALLATION</p> <p>EXHIBIT 5</p> <p>NOTICE TO PROCEED: THIS CONTRACT IS TO BE PERFORMED WITHIN 45 CALENDAR DAYS AFTER THE NOTICE TO PROCEED IS RECEIVED. UNLESS OTHERWISE SPECIFIED, THE FULLY EXECUTED PURCHASE ORDER WILL BE CONSIDERED NOTICE TO PROCEED.</p> <p>CANCELLATION: THE DIRECTOR OF PURCHASING RESERVES THE RIGHT TO CANCEL THIS CONTRACT IMMEDIATELY UPON WRITTEN NOTICE TO THE VENDOR IF THE MATERIALS OR WORKMANSHIP SUPPLIED ARE OF AN INFERIOR QUALITY OR DO NOT CONFORM</p>						

SEE REVERSE SIDE FOR TERMS AND CONDITIONS

SIGNATURE	TELEPHONE	DATE
TITLE	FEIN	ADDRESS CHANGES TO BE NOTED ABOVE

WHEN RESPONDING TO RFQ, INSERT NAME AND ADDRESS IN SPACE ABOVE LABELED 'VENDOR'

**GENERAL TERMS & CONDITIONS
REQUEST FOR QUOTATION (RFQ) AND REQUEST FOR PROPOSAL (RFP)**

1. Awards will be made in the best interest of the State of West Virginia.
2. The State may accept or reject in part, or in whole, any bid.
3. All quotations are governed by the *West Virginia Code* and the *Legislative Rules* of the Purchasing Division.
4. Prior to any award, the apparent successful vendor must be properly registered with the Purchasing Division and have paid the required \$125.00 registration fee.
5. All services performed or goods delivered under State Purchase Orders/Contracts are to be continued for the term of the Purchase Order/Contract, contingent upon funds being appropriated by the Legislature or otherwise being made available. In the event funds are not appropriated or otherwise available for these services or goods, this Purchase Order/Contract becomes void and of no effect after June 30.
6. Payment may only be made after the delivery and acceptance of goods or services.
7. Interest may be paid for late payment in accordance with the *West Virginia Code*.
8. Vendor preference will be granted upon written request in accordance with the *West Virginia Code*.
9. The State of West Virginia is exempt from federal and state taxes and will not pay or reimburse such taxes.
10. The Director of Purchasing may cancel any Purchase Order/Contract upon 30 days written notice to the seller.
11. The laws of the State of West Virginia and the *Legislative Rules* of the Purchasing Division shall govern all rights and duties under the Contract, including without limitation the validity of this Purchase Order/Contract.
12. Any reference to automatic renewal is hereby deleted. The Contract may be renewed only upon mutual written agreement of the parties.
13. **BANKRUPTCY:** In the event the vendor/contractor files for bankruptcy protection, this contract is automatically null and void, and is terminated without further order.
14. **HIPAA Business Associate Addendum -** The West Virginia State Government HIPAA Business Associate Addendum (BAA), approved by the Attorney General, and available online at the Purchasing Division's web site (<http://www.state.wv.us/admin/purchase/vrc/hipaa.htm>) is hereby made part of the agreement. Provided that, the Agency meets the definition of a Covered Entity (45 CFR §160.103) and will be disclosing Protected Health Information (45 CFR §160.103) to the vendor.

INSTRUCTIONS TO BIDDERS

1. Use the quotation forms provided by the Purchasing Division.
2. **SPECIFICATIONS:** Items offered must be in compliance with the specifications. Any deviation from the specifications must be clearly indicated by the bidder. Alternates offered by the bidder as **EQUAL** to the specifications must be clearly defined. A bidder offering an alternate should attach complete specifications and literature to the bid. The Purchasing Division may waive minor deviations to specifications.
3. Complete all sections of the quotation form.
4. Unit prices shall prevail in cases of discrepancy.
5. All quotations are considered F.O.B. destination unless alternate shipping terms are clearly identified in the quotation.
6. **BID SUBMISSION:** All quotations must be delivered by the bidder to the office listed below prior to the date and time of the bid opening. Failure of the bidder to deliver the quotations on time will result in bid disqualifications.

SIGNED BID TO:

Department of Administration
Purchasing Division
2019 Washington Street East
Post Office Box 50130
Charleston, WV 25305-0130



State of West Virginia
 Department of Administration
 Purchasing Division
 2019 Washington Street East
 Post Office Box 50130
 Charleston, WV 25305-0130

Request for Quotation

RFQ NUMBER
COR61340

PAGE
2

ADDRESS CORRESPONDENCE TO ATTENTION OF
JOHN ABBOTT 304-558-2544

VENDOR	RFQ COPY
	TYPE NAME/ADDRESS HERE

SHIP TO	DIVISION OF CORRECTIONS
	617 LEON SULLIVAN WAY
	CHARLESTON, WV
	25301 304-558-8045

DATE PRINTED	TERMS OF SALE	SHIP VIA	F.O.B.	FREIGHT TERMS
02/22/2007				

BID OPENING DATE: 03/21/2007 BID OPENING TIME 01:30PM

LINE	QUANTITY	UOP	CAT NO	ITEM NUMBER	UNIT PRICE	AMOUNT
<p>WITH THE SPECIFICATIONS OF THE BID AND CONTRACT HERE IN.</p> <p>WAGE RATES: THE CONTRACTOR OR SUBCONTRACTOR SHALL PAY THE HIGHER OF THE U.S. DEPARTMENT OF LABOR MINIMUM WAGE RATES AS ESTABLISHED FOR FAYETTE COUNTY, PURSUANT TO WEST VIRGINIA CODE 21-5A, ET, SEQ. (PREVAILING WAGE RATES APPLY TO THIS PROJECT)</p> <p>ARBITRATION: ANY REFERENCES MADE TO ARBITRATION OR INTEREST FOR PAYMENTS DUE (EXCEPT FOR ANY INTEREST REQUIRED BY STATE LAW) CONTAINED IN THIS CONTRACT OR IN ANY AMERICAN INSTITUTE OF ARCHITECTS DOCUMENTS PERTAINING TO THIS CONTRACT ARE HEREBY DELETED.</p> <p>WORKERS' COMPENSATION: VENDOR IS REQUIRED TO PROVIDE A CERTIFICATE FROM WORKERS' COMPENSATION IF SUCCESSFUL.</p> <p>ALL OF THE ITEMS CHECKED BELOW WILL BE A REQUIREMENT OF THIS CONTRACT:</p> <p>(XX) INSURANCE: SUCCESSFUL VENDOR SHALL FURNISH PROOF OF COMMERCIAL GENERAL LIABILITY INSURANCE PRIOR TO ISSUANCE OF CONTRACT. UNLESS OTHERWISE SPECIFIED IN THE BID DOCUMENTS, THE MINIMUM AMOUNT OF INSURANCE COVERAGE REQUIRED IS \$250,000.</p> <p>() BUILDERS RISK INSURANCE: SUCCESSFUL VENDOR SHALL FURNISH PROOF OF BUILDERS RISK - ALL RISK INSURANCE IN AN AMOUNT EQUAL TO 100% OF THE AMOUNT OF THE CONTRACT.</p> <p>(XX) BONDS: FIVE PERCENT (5%) OF THE TOTAL AMOUNT OF THE BID PAYABLE TO THE STATE OF WEST VIRGINIA, SHALL BE SUBMITTED WITH EACH BID AS A BID BOND. THE SUCCESSFUL BIDDER SHALL ALSO FURNISH A PERFORMANCE BOND AND LABOR/MATERIAL BOND FOR 100% OF THE AMOUNT OF THE CONTRACT.</p>						

SEE REVERSE SIDE FOR TERMS AND CONDITIONS

SIGNATURE	TELEPHONE	DATE
TITLE	FEIN	ADDRESS CHANGES TO BE NOTED ABOVE

WHEN RESPONDING TO RFQ, INSERT NAME AND ADDRESS IN SPACE ABOVE LABELED 'VENDOR'



State of West Virginia
 Department of Administration
 Purchasing Division
 2019 Washington Street East
 Post Office Box 50130
 Charleston, WV 25305-0130

Request for Quotation

RFQ NUMBER
COR61340

PAGE
3

ADDRESS CORRESPONDENCE TO ATTENTION OF
**JOHN ABBOTT
 304-558-2544**

RFQ COPY
 TYPE NAME/ADDRESS HERE

VENDOR

SHIP TO

**DIVISION OF CORRECTIONS
 617 LEON SULLIVAN WAY
 CHARLESTON, WV
 25301 304-558-8045**

DATE PRINTED	TERMS OF SALE	SHIP VIA	F.O.B.	FREIGHT TERMS
02/22/2007				

BID OPENING DATE: **03/21/2007** BID OPENING TIME **01:30PM**

LINE	QUANTITY	UOP	CAT NO.	ITEM NUMBER	UNIT PRICE	AMOUNT
<p>BONDS MAY BE PROVIDED IN THE FORM OF A CERTIFIED CHECK, IRREVOCABLE LETTER OF CREDIT, OR BOND FURNISHED BY A SOLVENT SURETY COMPANY AUTHORIZED TO DO BUSINESS IN THE STATE OF WEST VIRGINIA. A LETTER OF CREDIT SUBMITTED IN LIEU OF A PERFORMANCE AND LABOR & MATERIAL BOND WILL ONLY BE ALLOWED FOR PROJECTS UNDER \$100,000. PERSONAL OR BUSINESS CHECKS ARE NOT ACCEPTABLE IN LIEU OF THE 5% BID BOND, PERFORMANCE BOND, OR LABOR AND MATERIAL BOND.</p> <p>(XX) MAINTENANCE BOND: A TWO (2) YEAR MAINTENANCE BOND COVERING THE ROOFING SYSTEM WILL BE A REQUIREMENT OF THE SUCCESSFUL VENDOR.</p> <p>REV. 11/00</p> <p>EXHIBIT 7</p> <p>DOMESTIC ALUMINUM, GLASS & STEEL IN PUBLIC WORKS PROJECTS</p> <p>IN ACCORDANCE WITH WEST VIRGINIA CODE 5-19-1 ET., SEQ., EVERY CONTRACT FOR CONSTRUCTION, RECONSTRUCTION, ALTERATION, REPAIR, IMPROVEMENT OR MAINTENANCE OF PUBLIC WORKS, WHERE THE COST IS MORE THAN \$50,000 AND, IN THE CASE OF STEEL ONLY, WHERE THE COST OF STEEL IS MORE THAN \$50,000 OR WHERE MORE THAN 10,000 POUNDS OF STEEL ARE REQUIRED, THE STATE WILL ACCEPT ONLY ALUMINUM GLASS, OR STEEL PRODUCTS PRODUCED IN THE UNITED STATES IN ADDITION, ITEMS OF MACHINERY OR EQUIPMENT PURCHASED FOR USE AT THE SITE OF PUBLIC WORKS SHALL BE MADE OF DOMESTIC ALUMINUM, GLASS OR STEEL, UNLESS THE COST OF THE PRODUCT IS LESS THAN \$50,000 OR LESS THAN 10,000 POUNDS OF STEEL ARE USED IN PUBLIC WORKS PROJECTS.</p>						

SEE REVERSE SIDE FOR TERMS AND CONDITIONS

SIGNATURE	TELEPHONE	DATE
TITLE	FEIN	ADDRESS CHANGES TO BE NOTED ABOVE

WHEN RESPONDING TO RFQ, INSERT NAME AND ADDRESS IN SPACE ABOVE LABELED 'VENDOR'



State of West Virginia
 Department of Administration
 Purchasing Division
 2019 Washington Street East
 Post Office Box 50130
 Charleston, WV 25305-0130

Request for Quotation

RFQ NUMBER
COR61340

PAGE
4

ADDRESS CORRESPONDENCE TO ATTENTION OF
**JOHN ABBOTT
 304-558-2544**

RFQ COPY
 TYPE NAME/ADDRESS HERE

VENDOR

SHIP TO

**DIVISION OF CORRECTIONS
 617 LEON SULLIVAN WAY
 CHARLESTON, WV
 25301 304-558-8045**

DATE PRINTED	TERMS OF SALE	SHIP VIA	F.O.B.	FREIGHT TERMS
02/22/2007				

BID OPENING DATE: **03/21/2007** BID OPENING TIME **01:30PM**

LINE	QUANTITY	UOP	CAT NO	ITEM NUMBER	UNIT PRICE	AMOUNT
<p>FOREIGN MADE ALUMINUM, GLASS OR STEEL PRODUCTS MAY BE ACCEPTED ONLY IF THE COST OF DOMESTIC PRODUCTS IS FOUND TO BE UNREASONABLE. SUCH COST IS UNREASONABLE IF IT IS 20% OR MORE HIGHER THAN THE BID PRICE FOR FOREIGN MADE PRODUCTS. IF THE DOMESTIC ALUMINUM, GLASS OR STEEL PRODUCTS TO BE SUPPLIED OR PRODUCED IN A "SUBSTANTIAL LABOR SURPLUS AREA", AS DEFINED BY THE UNITED STATES DEPARTMENT OF LABOR, FOREIGN PRODUCTS MAY BE SUPPLIED ONLY IF DOMESTIC PRODUCTS ARE 30% OR MORE HIGHER IN PRICE THAN THE FOREIGN MADE PRODUCTS.</p> <p>IF, PRIOR TO THE AWARD OF A CONTRACT UNDER THE ABOVE PROVISIONS, THE SPENDING OFFICER OF THE SPENDING UNIT DETERMINES THAT THERE EXISTS A BID FOR LIKE FOREIGN ALUMINUM, GLASS OR STEEL THAT IS REASONABLE AND LOWER THAN THE LOWEST BID DOMESTIC PRODUCTS, THE SPENDING OFFICE MAY REQUEST, IN WRITING, A REEVALUATION AND REDUCTION IN THE LOWEST BID FOR SUCH DOMESTIC PRODUCTS ALL VENDORS MUST INDICATE IN THEIR BID IF THEY ARE SUPPLYING FOREIGN ALUMINUM, GLASS OR STEEL.</p> <p>REV. 3/88</p> <p>EXHIBIT 9</p> <p>NOTICE FOR ISSUANCE & ACKNOWLEDGEMENT OF CONSTRUCTION PROJECT ADDENDA</p> <p>THE ARCHITECT/ENGINEER AND/OR AGENCY SHALL BE REQUIRED TO ABIDE BY THE FOLLOWING SCHEDULE IN ISSUING CONSTRUCTION PROJECT ADDENDA FOR STATE AGENCIES:</p> <p>(1) THE ARCHITECT/ENGINEER SHALL PREPARE THE ADDENDUM AND A LIST OF ALL PARTIES THAT HAVE PROCURED DRAWINGS AND SPECIFICATIONS FOR THE PROJECT. THE ADDENDUM</p>						

SEE REVERSE SIDE FOR TERMS AND CONDITIONS

SIGNATURE	TELEPHONE	DATE
TITLE	FEIN	ADDRESS CHANGES TO BE NOTED ABOVE

WHEN RESPONDING TO RFQ, INSERT NAME AND ADDRESS IN SPACE ABOVE LABELED 'VENDOR'



State of West Virginia
 Department of Administration
 Purchasing Division
 2019 Washington Street East
 Post Office Box 50130
 Charleston, WV 25305-0130

Request for Quotation

RFQ NUMBER
COR61340

PAGE
5

ADDRESS CORRESPONDENCE TO ATTENTION OF:
JOHN ABBOTT
304-558-2544

RFQ COPY
 TYPE NAME/ADDRESS HERE

VENDOR

SHIP TO

DIVISION OF CORRECTIONS
617 LEON SULLIVAN WAY
CHARLESTON, WV
25301 304-558-8045

DATE PRINTED	TERMS OF SALE	SHIP VIA	F.O.B.	FREIGHT TERMS
02/22/2007				

BID OPENING DATE: **03/21/2007** BID OPENING TIME **01:30PM**

LINE	QUANTITY	UOP	CAT NO.	ITEM NUMBER	UNIT PRICE	AMOUNT
				<p>AND LIST SHALL BE FORWARDED TO THE BUYER IN THE STATE PURCHASING DIVISION. THE ARCHITECT/ENGINEER SHALL ALSO SEND A COPY OF THE ADDENDUM TO THE STATE AGENCY FOR WHICH THE CONTRACT IS ISSUED.</p> <p>(2) THE BUYER SHALL SEND THE ADDENDUM TO ALL INTERESTED PARTIES AND, IF NECESSARY, EXTEND THE BID OPENING DATE. ANY ADDENDUM SHOULD BE RECEIVED BY THE BUYER WITHIN FOURTEEN (14) DAYS PRIOR TO THE BID OPENING DATE.</p> <p>(3) ALL ADDENDA SHOULD BE FORMALLY ACKNOWLEDGED BY ALL BIDDERS AND SUBMITTED TO THE STATE PURCHASING DIVISION. THE SAME RULES AND REGULATIONS THAT APPLY TO THE ORIGINAL BIDDING DOCUMENT SHALL ALSO APPLY TO AN ADDENDUM DOCUMENT. THE ONLY EXCEPTION MAY BE FOR AN ADDENDUM THAT IS ISSUED FOR THE SOLE PURPOSE OF CHANGING A BID OPENING TIME AND/OR DATE.</p> <p>REV. 11/96</p> <p>EXHIBIT 10</p> <p>ADDENDUM ACKNOWLEDGEMENT</p> <p>I HEREBY ACKNOWLEDGE RECEIPT OF THE FOLLOWING CHECKED ADDENDUM(S) AND HAVE MADE THE NECESSARY REVISIONS TO MY PROPOSAL, PLANS AND/OR SPECIFICATION, ETC.</p> <p>ADDENDUM NOS.:</p> <p>NO. 1</p> <p>NO. 2</p>		

SEE REVERSE SIDE FOR TERMS AND CONDITIONS

SIGNATURE	TELEPHONE	DATE
TITLE	FEIN	ADDRESS CHANGES TO BE NOTED ABOVE

WHEN RESPONDING TO RFQ, INSERT NAME AND ADDRESS IN SPACE ABOVE LABELED 'VENDOR'



State of West Virginia
 Department of Administration
 Purchasing Division
 2019 Washington Street East
 Post Office Box 50130
 Charleston, WV 25305-0130

Request for Quotation

RFQ NUMBER
COR61340

PAGE
6

ADDRESS CORRESPONDENCE TO ATTENTION OF
**JOHN ABBOTT
 304-558-2544**

RFQ COPY
 TYPE NAME/ADDRESS HERE

VENDOR

SHIP TO

**DIVISION OF CORRECTIONS
 617 LEON SULLIVAN WAY
 CHARLESTON, WV
 25301 304-558-8045**

DATE PRINTED	TERMS OF SALE	SHIP VIA	F.O.B.	FREIGHT TERMS
02/22/2007				

BID OPENING DATE: **03/21/2007** BID OPENING TIME **01:30PM**

LINE	QUANTITY	UOP	CAT NO.	ITEM NUMBER	UNIT PRICE	AMOUNT
NO. 3				
NO. 4				
NO. 5				
<p>I UNDERSTAND THAT FAILURE TO CONFIRM THE RECEIPT OF THE ADDENDUM(S) MAY BE CAUSE FOR REJECTION OF THE BIDS.</p> <p>.....SIGNATURE</p> <p>.....COMPANY</p> <p>.....DATE</p> <p>REV. 11/96</p> <p>CONTRACTORS LICENSE</p> <p>WEST VIRGINIA STATE CODE 21-11-2 REQUIRES THAT ALL PERSONS DESIRING TO PERFORM CONTRACTING WORK IN THIS STATE MUST BE LICENSED. THE WEST VIRGINIA CONTRACTORS LICENSING BOARD IS EMPOWERED TO ISSUE THE CONTRACTORS LICENSE. APPLICATIONS FOR A CONTRACTORS LICENSE MAY BE MADE BY CONTACTING THE WEST VIRGINIA DIVISION OF LABOR CAPITOL COMPLEX, BUILDING 3, ROOM 319, CHARLESTON, WV 25305. TELEPHONE: (304) 558-7890.</p> <p>WEST VIRGINIA STATE CODE 21-11-11 REQUIRES ANY PROSPECTIVE BIDDER TO INCLUDE THE CONTRACTORS LICENSE NUMBER ON THEIR BID.</p> <p>BIDDER TO COMPLETE:</p>						

SEE REVERSE SIDE FOR TERMS AND CONDITIONS

SIGNATURE	TELEPHONE	DATE
TITLE	FEIN	ADDRESS CHANGES TO BE NOTED ABOVE

WHEN RESPONDING TO RFQ, INSERT NAME AND ADDRESS IN SPACE ABOVE LABELED 'VENDOR'



State of West Virginia
 Department of Administration
 Purchasing Division
 2019 Washington Street East
 Post Office Box 50130
 Charleston, WV 25305-0130

Request for Quotation

RFQ NUMBER
COR61340

PAGE
7

ADDRESS CORRESPONDENCE TO ATTENTION OF
**JOHN ABBOTT
 304-558-2544**

RFQ COPY
 TYPE NAME/ADDRESS HERE

VENDOR

SHIP TO

**DIVISION OF CORRECTIONS
 617 LEON SULLIVAN WAY
 CHARLESTON, WV
 25301 304-558-8045**

DATE PRINTED	TERMS OF SALE	SHIP VIA	F.O.B.	FREIGHT TERMS
02/22/2007				

BID OPENING DATE: **03/21/2007** BID OPENING TIME **01:30PM**

LINE	QUANTITY	UOP	CAT. NO.	ITEM NUMBER	UNIT PRICE	AMOUNT
<p>CONTRACTORS NAME:</p> <p>CONTRACTORS LICENSE NO.:</p> <p>THE SUCCESSFUL BIDDER WILL BE REQUIRED TO FURNISH A COPY OF THEIR CONTRACTORS LICENSE PRIOR TO ISSUANCE OF A PURCHASE ORDER/CONTRACT</p> <p style="text-align: center;">APPLICABLE LAW</p> <p>THE WEST VIRGINIA STATE CODE, PURCHASING DIVISION RULE AND REGULATIONS, AND THE INFORMATION PROVIDED IN THE "REQUEST FOR QUOTATION" ISSUED BY THE PURCHASING DIVISION IS THE SOLE AUTHORITY GOVERNING THIS PROCUREMENT.</p> <p>ANY INFORMATION PROVIDED IN SPECIFICATION MANUALS, OR ANY OTHER SOURCE, VERBAL OR WRITTEN, WHICH CONTRADICTS OR ALTERS THE INFORMATION PROVIDED FROM THE SOURCES AS DESCRIBED IN THE ABOVE PARAGRAPH IS VOID AND OF NO EFFECT.</p> <p>BANKRUPTCY: IN THE EVENT THE VENDOR/CONTRACTOR FILES FOR BANKRUPTCY PROTECTION, THIS CONTRACT IS AUTOMATICALLY NULL AND VOID, AND IS TERMINATED WITHOUT FURTHER ORDER.</p> <p>REV. 1/2005</p> <p style="text-align: center;">NOTICE</p> <p>A SIGNED BID MUST BE SUBMITTED TO: DEPARTMENT OF ADMINISTRATION</p>						

SEE REVERSE SIDE FOR TERMS AND CONDITIONS

SIGNATURE	TELEPHONE	DATE
TITLE	FEIN	ADDRESS CHANGES TO BE NOTED ABOVE

WHEN RESPONDING TO RFQ, INSERT NAME AND ADDRESS IN SPACE ABOVE LABELED 'VENDOR'



State of West Virginia
 Department of Administration
 Purchasing Division
 2019 Washington Street East
 Post Office Box 50130
 Charleston, WV 25305-0130

Request for Quotation

RFQ NUMBER
COR61340

PAGE
8

ADDRESS CORRESPONDENCE TO ATTENTION OF
JOHN ABBOTT
304-558-2544

VENDOR

RFQ COPY
 TYPE NAME/ADDRESS HERE

SHIP TO

DIVISION OF CORRECTIONS
 617 LEON SULLIVAN WAY
 CHARLESTON, WV
 25301 304-558-8045

DATE PRINTED	TERMS OF SALE	SHIP VIA	F.O.B.	FREIGHT TERMS
02/22/2007				

BID OPENING DATE: **03/21/2007** BID OPENING TIME **01:30PM**

LINE	QUANTITY	UOP	CAT. NO.	ITEM NUMBER	UNIT PRICE	AMOUNT
PURCHASING DIVISION BUILDING 15 2019 WASHINGTON STREET, EAST CHARLESTON, WV 25305-0130						
THE BID SHOULD CONTAIN THIS INFORMATION ON THE FACE OF THE ENVELOPE OR THE BID MAY NOT BE CONSIDERED: SEALED BID BUYER: JOHN ABBOTT----- REQ. NO.: COR61340----- BID OPENING DATE: 3/21/2007----- BID OPENING TIME:----- PLEASE PROVIDE A FAX NUMBER IN CASE IT IS NECESSARY TO CONTACT YOU REGARDING YOUR BID: ----- PLEASE PRINT OR TYPE NAME OF PERSON TO CONTACT CONCERNING THIS QUOTE: -----						

SEE REVERSE SIDE FOR TERMS AND CONDITIONS

SIGNATURE	TELEPHONE	DATE
TITLE	FEIN	ADDRESS CHANGES TO BE NOTED ABOVE

WHEN RESPONDING TO RFQ, INSERT NAME AND ADDRESS IN SPACE ABOVE LABELED 'VENDOR'



State of West Virginia
 Department of Administration
 Purchasing Division
 2019 Washington Street East
 Post Office Box 50130
 Charleston, WV 25305-0130

Request for Quotation

RFQ NUMBER
COR61340

PAGE
9

ADDRESS CORRESPONDENCE TO ATTENTION OF
**JOHN ABBOTT
 304-558-2544**

**RFQ COPY
 TYPE NAME/ADDRESS HERE**

VENDOR

SHIP TO

**DIVISION OF CORRECTIONS
 617 LEON SULLIVAN WAY
 CHARLESTON, WV
 25301 304-558-8045**

DATE PRINTED	TERMS OF SALE	SHIP VIA	F.O.B.	FREIGHT TERMS
02/22/2007				

BID OPENING DATE: **03/21/2007** BID OPENING TIME **01:30PM**

LINE	QUANTITY	UOP	CAT. NO.	ITEM NUMBER	UNIT PRICE	AMOUNT
***** THIS IS THE END OF RFQ COR61340 ***** TOTAL:						

SEE REVERSE SIDE FOR TERMS AND CONDITIONS

SIGNATURE		TELEPHONE	DATE
TITLE	FEIN	ADDRESS CHANGES TO BE NOTED ABOVE	

WHEN RESPONDING TO RFQ, INSERT NAME AND ADDRESS IN SPACE ABOVE LABELED 'VENDOR'

WV-36A (Rev. 01/01/07)

**STATE OF WEST VIRGINIA
PURCHASE CONTINUATION SHEET**

Vendor: _____

Buyer: 32	Page:	Requisition or P.O. No.: COR61340
Spending Unit: Mt Olive Corr Center		

Replace all eleven (11) existing York roof top package units with like York units. M/N : DM300N32P2BEB1 OR EQUAL

These units will be supplied with the following factory installed items:

- Single enthalpy economizer
- Unit mounted disconnect switch
- High static drive
- Phase Monitor
- Air proving switch
- Hinged filter door & tool-less access
- UNT Controller
- Dirty filter switch

These units will also be installed with the following field installed items:

- Economizer rain hood
- Barometric relief damper 1RD0406

Recovery and disposal of refrigerant per EPA regulations

Units to have DDC control and access through a web based controller, described in Part 2. Basics to include:

- Alarming of points to email, pager or text message to a cell phone
- Remote access of trouble shooting and off site assistance to maintenance department
- Set point adjustment from workstation
- All temperatures and control points also available at workstation
- Available expansion for other control of building AHU's, boilers, chillers and additional sensors
- Web based access via Internet Explorer 6 or higher

The web-based controller will also be accessible from a remote location for emergency and PM services.

Factory Operation and Service manuals, and Parts manual will be provided.

One day customer training on the operation of the new HVAC system will be provided.

As built drawings will be provided upon completion of project.

The existing type of control on the RTU's will be replaced with a Metasys Web Based Internet System.

A new laptop workstation is to be supplied by the Contractor for use in the mechanical room by Mt Olive maintenance personnel. Workstation requirements listed in Part 2 Section 1.2.

Detailed specifications follow .

1.1 FMS Architecture

Provide a Metasys NAE web based front end capable of providing Internet WebAccess

A. Overall Conceptual Description

1. The FMS shall be designed entirely for use on intranets and internets. All networking technology used at the Tier 1 level shall be off the shelf, industry standard technology fully compatible with other owner provided networks in the facility.
2. All aspects of the user interface, whether to servers or to Tier 1 solid state devices, shall be via browsers. Any PCs used as operator interface points shall not require the purchase of any special software from the manufacturer in order to provide the complete user interface as described herein.
3. The user interface will be complete as described herein, providing complete tool sets, operational features, multi-panel displays, and other display features. Systems which merely provide HTML based web pages as the operator interface will not be acceptable.
4. The primary components of the system will be the Primary Application Nodes and Servers located at the highest level of the network architecture. Both will use the same user interface and provide the same level of accessibility via the network. The only distinction between the user interface used on servers as compared to Primary Application Nodes will be select menu items used for accessing long term storage features on the servers or on their respective archive devices (CD/RW, etc.)

B. General

1. The FMS shall consist of a number of Nodes and associated equipment connected by industry standard network practices. All communication between Nodes shall be by digital means only.
2. The FMS network shall at minimum comprise of the following:
 - a. Operator PCs – fixed or portable
 - b. Network processing, data storage and communication equipment including file servers
 - c. Routers, bridges, switches, hubs, modems and like communications equipment.
 - d. Active processing Nodes including field panels.
 - e. Intelligent and addressable elements and end devices.
 - f. Third-party equipment interfaces.
 - g. Other components required for a complete and working FMS.
3. All FMS features shall be accessible via Enterprise Intranet and Internet browser with equivalent FMS access control for user access.
4. The FMS shall support auto-dial/auto-answer communications to allow FMS Nodes to communicate with other remote FMS Nodes via standard telephone lines. Refer to drawings for type of line to be used, DSL or voice grade. Where no preference is indicated, DSL is the preferred grade.
5. The PC Workstations, File servers and principal network equipment shall be standard products of recognized major manufacturers available through normal PC vendor channels. "Clones" are not acceptable.
6. Provide licenses for all software residing in the FMS system and transfer these licenses to the Owner prior to completion.

C. Network

1. The FMS shall incorporate a primary Tier 1 network. At the Contractor's option, the FMS may also incorporate integrated secondary Tier 2 and tertiary Tier 3 networks.
2. The FMS Network shall utilize an open architecture capable of all of the following:
 - a. Utilizing standard Ethernet communications and operate at a minimum speed of 10/100 Mb/sec
 - b. Connecting via BACnet at the Tier 1 level in accordance with as per ANSI/ASHRAE Standard 135-2001
 - c. Connecting via the N2 Protocol at the Tier 2 level
 - d. Connecting via LonMark as per ANSI/EIA 709 (LonWorks) to LonMark FTT-10 transceivers at the Tier 2 level
3. The FMS network shall support both copper and optical fiber communication media.

D. Third-Party Interfaces

1. FMS Contractor shall integrate, if required for future use, real-time data from systems supplied by other trades.
2. The FMS system shall include necessary FMS hardware equipment and software to allow data communications between the FMS system and systems supplied by other trades.

E. Power Fail / Auto Restart

1. Provide for the automatic orderly and predefined shutdown of parts or all of the FMS following total loss of power to parts or all of the FMS.

2. Provide for the automatic orderly and predefined startup of parts or all of the FMS following total loss of power to those parts or all of the FMS. Archive and annunciate time and details of restoration.
3. Provide for the orderly and predefined scheduling of controlled return to normal, automatically time scheduled, operation of controlled equipment as a result of the auto restart processes.
4. Maintain the FMS real-time clock operation during periods of power outage for a minimum of 72 hours.

F. Downloading and Uploading

1. Provide the capability to generate FMS software-based sequences, database items and associated operational definition information and user-required revisions to same at any Operator PC, and the means to download same to the associated Application Node.
2. Application software tool used for the generation of custom logic sequences shall be resident in the application node where indicated on the drawings.
3. Provide the capability to upload FMS operating software information, database items, sequences and alarms.
4. The functions of this Part shall be governed by the codes, approvals and regulations applying to each individual FMS application.

1.2 Operator PCs

- A. The Operator PCs (PCs) shall provide the primary means of communication with the FMS and shall be used for operations, engineering, management, audit, reporting and other related functions.
- B. The PCs shall consist of fixed and portable units. The fixed units shall consist of installed PC-based configurations. The portable units shall consist of PC Laptop or similar designed unit, complete with keyboard or similar entry/selection device and complete with display and communication arrangements with ANs.
- C. Each fixed PC shall, at minimum, consist of:
 1. PC processor with minimum 64-bit word structure
 2. Hard drive or equal high-speed data storage
 3. Removable high-speed data storage and export device(s) such as Read/Write CD ROM or equal
 4. Full ASCII keyboard and digital Mouse or equal pointing device
 5. Full color, flat screen VDU display unit, minimum 17 inches diagonal screen, minimum 1280 x 1024 resolution, 0.26 or better dot pitch and minimum 72 Hz refresh rate.
 6. Printers as scheduled in Part 3 of this Specification. Printers shall be monochromatic or full color as scheduled and designed for the functional requirements and duty of the application.
- D. All fixed PCs shall operate independently and concurrently without interference and under individual user password protection.
- E. PCs functionality shall be individually definable by software means such that PC may be designated for specific limited users and may also be readily re-designated to provide OWS back-up to other OWSs in the FMS.
- F. Portable PC shall operate identically to the fixed PC.

- G. Fixed or portable operator PCs shall not require any special software to be purchased from the FMS manufacturer. All actions required for the complete operator interface as described herein shall be accomplished through a common browser.

1.3 Operator Interface

A. General

1. The FMS Operator Interface shall be user friendly, readily understood and shall make maximum use of colors, graphics, icons, embedded images, animation, text based information and data visualization techniques to enhance and simplify the use and understanding of the FMS by authorized users at the OWS.
2. It shall be possible to designate any PC on the Tier 1 network as an Operator Interface point. No special software will need to be purchased from the FMS manufacturer for any such PC.
3. User access to the FMS shall be protected by a flexible and Owner redefinable software-based password access protection. Password protection shall be multi-level and partitionable to accommodate the varied access requirements of the different user groups. Provide the means to define unique access privileges for each individual authorized user. Also provide the means to establish general password groups to which an individual will then be assigned. Once assigned to the group each individual will assume all the capabilities and restrictions of that group. Provide the means to on-line manage password access control under the control of a Master Password.
4. The user interface shall be able to combine data from any and all of the system components in a single browser window. This shall include historical data stored on a server.
5. The Operator Interface shall incorporate comprehensive support for functions including, but not necessarily limited to, the following:
 - a. User access for selective information retrieval and control command execution
 - b. Monitoring and reporting
 - c. Alarm, non-normal, and return to normal condition annunciation
 - d. Selective operator override and other control actions
 - e. Information archiving, manipulation, formatting, display and reporting
 - f. FMS internal performance supervision and diagnostics
 - g. On-line access to user HELP menus
 - h. On-line access to current FMS as-built records and documentation
 - i. Means for the controlled re-programming, re-configuration of FMS operation and for the manipulation of FMS database information in compliance with the prevailing codes, approvals and regulations for individual FMS applications
6. Provide FMS reports and displays making maximized use of simple English language descriptions and readily understood acronyms, abbreviations and the like to assist user understanding and interpretation. All text naming conventions shall be consistent in their use and application throughout the FMS.

7. All PC-based configurations shall operate on Microsoft® Windows 2000 or Windows XP.
8. Each fixed and portable PC shall be on-line configurable for specific applications, functions and groups of FMS points.

B. Navigation Trees

1. The system will have the capability to display multiple navigation trees that will aid the operator in navigating throughout all systems and points connected. At minimum provide a tree that identifies all systems on the networks.
2. Provide the ability for the operator add custom trees. The operator will be able to define any logical grouping of systems or points and arrange them on the tree in any order. It shall be possible to nest groups within other groups. Provide at minimum 5 levels of nesting.
3. The navigation trees shall be “dockable” to other displays in the user interface such as graphics. This means that the trees will appear as part of the display, but can be detached and then minimized to the Windows task bar or closed altogether. A simple keystroke will reattach the navigation to the primary display of the user interface.

C. Dividable display panels

1. It shall be possible for the operator to divide the display area within a single browser window into multiple display panels. The content of each display panel can be any of the standard summaries and graphics provided by the system.
2. Provide each display panel with minimize, maximize, and close icons.

D. Alarms

1. Alarms shall be routed directly from primary application nodes to PCs and servers. It shall be possible for specific alarms from specific points to be routed to specific PCs and servers. The alarm management portion of the OWS software shall, at the minimum, provide the following functions
 - a. Log date and time of alarm occurrence.
 - b. Generate a “Pop-Up” window, with audible alarm, informing a user that an alarm has been received.
 - c. Allow a user, with the appropriate security level, to acknowledge, temporarily silence, or discard an alarm.
 - d. Provide an audit trail on hard drive for alarms by recording user acknowledgment, deletion, or disabling of an alarm. The audit trail shall include the name of the user, the alarm, the action taken on the alarm, and a time/date stamp.
 - e. Provide the ability to direct alarms to an e-mail address or alpha-numeric pager. This must be provided in addition to the pop up window described above. Systems which use e-mail and pagers as the exclusive means of annunciating alarms are not acceptable.
 - f. Any attribute of any object in the system may be designated to report an alarm.
2. The FMS shall annunciate diagnostic alarms indicating system failures and non-normal operating conditions
3. The FMS shall annunciate application alarms at minimum, as required by Part 3.

E. Reports

1. Reports shall be generated and directed to one or more of the following: User interface displays, printers, or archive at the user's option. As a minimum, the system shall provide the following reports:
 - a. All points in the FMS.
 - b. All points in each FMS application.
 - c. All points in a specific AN.
 - d. All points in a user-defined group of points.
 - e. All points currently in alarm in an FMS application.
 - f. All points locked out in an FMS application.
 - g. All FMS schedules
 - h. All user defined and adjustable variables, schedules, interlocks and the like.
 - i. FMS diagnostic and system status reports
2. Provide all applicable standard reports of the FMS manufacturer.
3. Provide for the generation by the user of custom reports as specified in Part 3.

F. Dynamic Color Graphics

1. An unlimited number of graphic displays shall be able to be generated and executed.
2. Graphics shall be based on Scalar Vector Graphic (SVG) technology.
3. Values of real time attributes displayed on the graphics shall be dynamic and updated on the displays.
4. The graphic displays shall be able to display and provide animation based on real-time FMS data that is acquired, derived, or entered.
5. The user shall be able to change values (setpoints) and states in system controlled equipment directly from the graphic display.
6. Provide a graphic editing tool that allows for the creation and editing of graphic files. It shall be possible to edit the graphics directly while they are on line, or at an off line location for later downloading to the AN.
7. FMS system shall be provided with a complete user expandable symbol library containing all of the basic symbols used to represent components of a typical FMS system. Implementing these symbols in a graphic shall involve dragging and dropping them from the library to the graphic.

G. Schedules

1. The system shall provide multiple schedule input forms for automatic FMS time-of-day scheduling and override scheduling of FMS operations. At a minimum, the following spreadsheet types shall be accommodated:
 - a. Weekly schedules
 - b. Temporary override schedules.
 - c. Special "Only Active If Today Is A Holiday" schedules.
 - d. Monthly schedules
2. Schedules shall be provided for each system or sub-system in the FMS. Each schedule shall include all commandable points residing within the system. Each point may have a unique schedule of operation relative to the system use schedule, allowing for sequential starting and control of equipment within the system. Scheduling and rescheduling of points shall be accomplished easily via the system schedule spreadsheets.

3. Monthly calendars for a 12-month period shall be provided that allow for simplified scheduling of holidays and special days in advance. Holidays and special days shall be user-selected with the pointing device or keyboard, and shall automatically reschedule equipment operation as previously defined on the weekly schedules.

H. Historical trending and data collection

1. Trend and store point history data for all FMS points and values as selected by the user.
2. The trend data shall be stored in a manner that allows custom queries and reports using industry-standard software tools.
3. At a minimum, provide the capability to perform statistical functions on the historical database:
 - a. Average
 - b. Arithmetic mean
 - c. Maximum/minimum values
 - d. Range – difference between minimum and maximum values.
 - e. Standard deviation
 - f. Sum of all values
 - g. Variance

I. Paging:

1. Provide the means of automatic alphanumeric paging of personnel for user-defined FMS events.
 - a. System shall support both numeric and alpha-numeric pagers, using Alphanumeric, PET, or IXO Protocol at the owner's option.
 - b. Users shall have the ability to modify the phone number or message to be displayed on the pager through the system software.
 - c. System shall utilize pager schedules to send pages to the personnel that are "on-call".
 - d. Contractor shall be responsible for providing a modem for connection to the paging service.

1.4 Application Nodes

A. Primary Application Nodes

1. The primary application node shall perform the function of monitoring all system variables, both from real hardware points, software variables, and controller parameters such as setpoints.
2. Application nodes shall be entirely solid state devices. No rigid disk drives will be permitted in the equipment rooms.
3. The primary application nodes shall manage and direct all information traffic on the Tier 1 network, between the Tier 1 and Tier2 networks, and to servers.
4. Any node on the Tier 1 network shall be equipped with all software necessary to drive the complete user interface including graphics on a browser connected to the node via the network or directly via a local port on the node.
5. The operating system of the application node shall support multi-user access. At minimum four users shall be able to access the same application node simultaneously.
6. Communication between nodes shall be per-to-peer via 10/100 Ethernet using the BACnet protocol.

7. The AN shall be capable of direct connection to multiple field busses using different protocols simultaneously as indicated below. Should the controller not support multiple field busses, install two primary nodes side by side.
 - a. An RS-485 serial field bus such as MSTP or the manufacturer's proprietary field bus.
 - b. A LON field bus for supervision and control of LON based controllers that conform to the Lon Talk standard.
8. The primary nodes will integrate data from both field busses into a common object structure. Data from both field busses will appear in common displays throughout the user interface in exactly the same format. It shall not be possible to determine which field buss the data originated on without reviewing the system configuration data.
9. AN shall be programmable and governed by the requirements of their applicable codes, approvals and regulations.
10. The AN shall be designed, packaged, installed, programmed and commissioned in consideration of their specific service and prevailing operating conditions. They shall be proven standard product of their original manufacturer and not a custom product for this Project.
11. A failure at an AN shall not cause failures or non-normal operation at any other system AN other than the possible loss of active real-time information from the failed AN.
12. Ancillary AN equipment, including interfaces and power supplies, shall not be operated at more than 80% of their rated service capacity.
13. AN shall comply with FCC Part 15 subpart J class A emission requirements.
14. Each primary node shall be equipped with the necessary un-interruptible power such that it will not cease operation during minor power outages, including those that occur upon transfer to emergency generator or other local power source not provided by the utility.

B. HVAC Node

1. HVAC Node shall provide both standalone and networked direct digital control of HVAC systems.
2. A dedicated HVAC Node shall be configured and provided for each primary HVAC system (air handler, chiller, boiler) and each terminal HVAC system (VAV Box, Unit Heater, Fan Coil Unit, Cabinet Heater, Heat Pump, Fan Powered Box, CV Box)
3. Each HVAC Node shall retain program, control algorithms, and setpoint information in non-volatile memory in the event of a power failure, and shall return to normal operation upon restoration of power.
4. Each HVAC Node shall report its communication status to the FMS. The FMS shall provide a system advisory upon communication failure and restoration.
5. For each primary HVAC system, provide means of indication of system performance and setpoints at, or adjacent to the HVAC Node.
6. For each primary HVAC system, provide a means to adjust setpoints and start/stop equipment at, or adjacent to the HVAC Node.
7. Provide a means to prevent unauthorized personnel from accessing setpoint adjustments and equipment control functions.

8. The HVAC Node shall provide the ability to download and upload configuration data, both locally at the Node and via the FMS communications network.
9. The HVAC Node shall be provided with a permanently-mounted local graphic terminal where required in the sequences of this specification. The local graphic terminal shall provide dynamic graphical representation of the associated system status, with the ability for the operator to enter commands with proper password protection.

1.5 Application Software

A. HVAC Application Software

1. **Event Messaging:** Provide for the automatic execution of user-defined messages on the occurrence of each predefined FMS real-time event including equipment/point status change, approaching limit or alarm, time of day and the like. Direct messages to any number of operator PCs, e-mail destinations, and pagers.
2. **Indoor Air Quality:** Provide monitoring of outside air, return air and supply air CO₂ concentration, calculate and maintain fresh air requirements. Adjust outdoor air intake to ensure return air CO₂ high level limit is not exceeded.
3. **Optimum Start/Stop:** Provide software to start equipment on a sliding schedule based upon indoor and outdoor conditions, to determine the minimum time of HVAC system operation needed to satisfy the space environmental requirements. The program shall also determine the earliest possible time to stop the mechanical systems. The optimum start/stop program shall operate in conjunction with, and be coordinated with, the scheduled start/stop and night setback programs.
4. **Auto Alarm Lockout:** Provide for scheduled and automatic lockout of alarm annunciation from equipment during non-normal operating conditions including shutdown, emergency power operation, fire alarm and the like.
5. **Energy monitoring:** Provide software to monitor and totalize consumption as measured by pulse meters.
6. **Event Initiated Programs and custom logic:** Provide software to define custom logic sequences that will reside in the nodes. The definition software will also reside in the node and be accessible via the standard user interface via a browser.
7. **System Restart:** Upon restoration of the AC power to an HVAC Node, automatically restart all equipment and restore all loads to the state as required by the FMS. Provide appropriate time delays to prevent demand surges or overload trips.
8. **Heavy Equipment Delays:** The system shall provide protection against excessive demand situations during start-up periods by automatically introducing time delays between successive start commands to heavy electrical loads.
9. **Runtime Totalization:** Automatically sample, calculate and store runtime hours for binary input and output points as listed in the point schedule of this specification.
10. **Analog/Pulse Totalization:** Sample, calculate and store consumption totals on a daily, weekly, or monthly basis for user-selected analog and binary pulse input-type points.

An emergency response will be in the process control that would consist of two responses activated by a software command.

Response includes:

1. External Threat: All fans (under DDC control) will be shut off and all dampers will be closed to minimize any air infiltration into the building.
2. Internal Threat: All fans (under DDC control) to be commanded on and all dampers commanded to the 100% open position, over riding any safeties possible, to exhaust as much air as possible from the building and introduce fresh air.
 - The threat response is only for DDC controlled components of the HVAC system and sealing of the dampers can only be as good as the existing equipment can provide.

Project Name Mt. Olive Correctional Facility
 Architect
 Engineer
 Purchaser
 Submitted By

QUANTITY: 11 UNITS DESIGNATION: Schedule No:

Model No: DM300N32P2BEB1

COOLING PERFORMANCE		
Total Capacity	317	MBH
Sensible Capacity	239	MBH
Efficiency (at ARI)	8.5	EER
Part Load Efficiency	8.30	IPLV
Ambient DB Temp	95.0	F
Entering DB Temp	80.0	F
Entering WB Temp	67.0	F
Leaving DB Temp	57.8	F
Leaving WB Temp	56.9	F
Power Input (w/o blower)	27.40	KW
Elevation	0	Ft
Sound Power		Dbels
HEATING PERFORMANCE		
Gas Fired Input @ Sea Level	400	MBH
Gas Fired Output @ Sea Level	320	MBH
Steady State Efficiency	80.0	%
Entering DB Temp	65.0	F
Leaving DB Temp	94.6	F
SUPPLY AIR BLOWER PERFORMANCE		
Supply Air	10000	CFM
Outside Air	1000	CFM
External Static Pressure	0.75	IWG
Duct Connection Location		Bottom
Blower Speed	1098	RPM
Motor Rating	15.0	HP
Power Input	9.73	KW
Brake Horsepower	11.53	BHP
ELECTRICAL DATA		
Power Supply	208-3-60	
Total Unit Ampacity	140.1	Amps
Maximum Overcurrent Device Fuse Size	175	Amps
DIMENSIONS & WEIGHT		
Height	53 in	Width 136 in
		Depth 92 in
Total Weight (incl factory options)	3230 Lbs	
CLEARANCES		
Front	36 in	Back 49 in
Bottom ¹	0 in	Top ² 72 in
Left Side (filter access)	36 in	
Right Side (outdoor coil)	36 in	

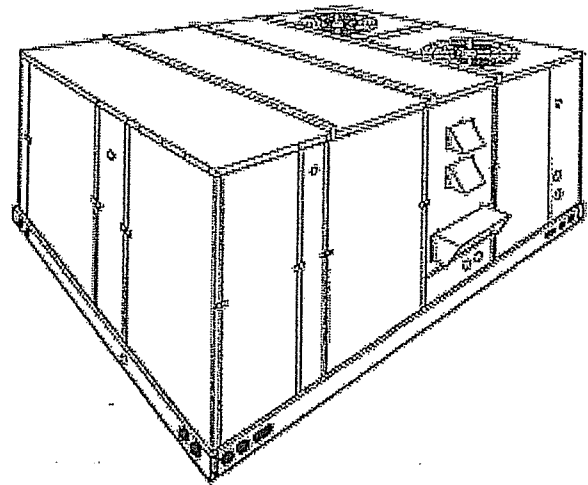

GENERAL FEATURES

- Complete Factory Package, Tested, Charged, Wired
- Multiple Independent Refrigeration Circuits
- Hermetically Sealed Compressors
- Spark Ignition - Induced Draft with Post Purge Logic on Gas Fired Units
- Belt Drive Blower Motor - Standard
- Bottom or Side Air Duct Configuration Capability
- PTC Type Crankcase Heaters
- Liquid Line Filter Driers
- High & Low Pressure / Loss of Charge and Freezestat Protection Switches
- 24 Volt Control Circuit with compressor lock out protection
- Permanently Lubricated Motors
- Simplicity™ Controls
- Two-Stage Heating
- 2" T/A Filters
- Copper Tube/Aluminum Fin Coils
- Easy Access to all Electrical Components
- Rigging Holes and Forklift Slots in Base Rails for Lifting
- Single Point Power Connection
- Powder Paint Finish That Meets ASTM-B117 1000 hr. Salt Spray Test Standards
- Agency Approvals (UL & CGA) on All Units
- Factory Warranty
 - One Year on the Complete Unit
 - Four Additional Years on the Compressors
 - Nine Additional Years on the Gas Fired Heat Exchanger

1. Units may be installed on combustible floors made from wood or class A, B or C roof covering materials.
 2. Units must be installed out doors. Overhanging structures or shrubs should not obstruct condenser air discharge outlet.
 Locate the unit so that the vent hood outlet is at least:
 - 3 feet above any forced air inlet located within 10 horizontal feet (excluding those integral to the unit).
 - 4 feet below, 4 horizontal feet from, or 1 foot above any door or gravity air inlet to the building.
 - 4 feet from electric meters, gas meters, regulators and relief equipment.

A 1 in. clearance must be provided between any combustible material and the supply air ductwork for a Distance of 3 feet from the unit. The products of combustion must not be allowed to accumulate within a confined space and recirculate.

Project Name Mt. Olive Correctional Facility
 Architect
 Engineer
 Purchaser
 Submitted By

QUANTITY: 11 UNITS DESIGNATION: Schedule No:

Model No: DM300N32P2BEB1

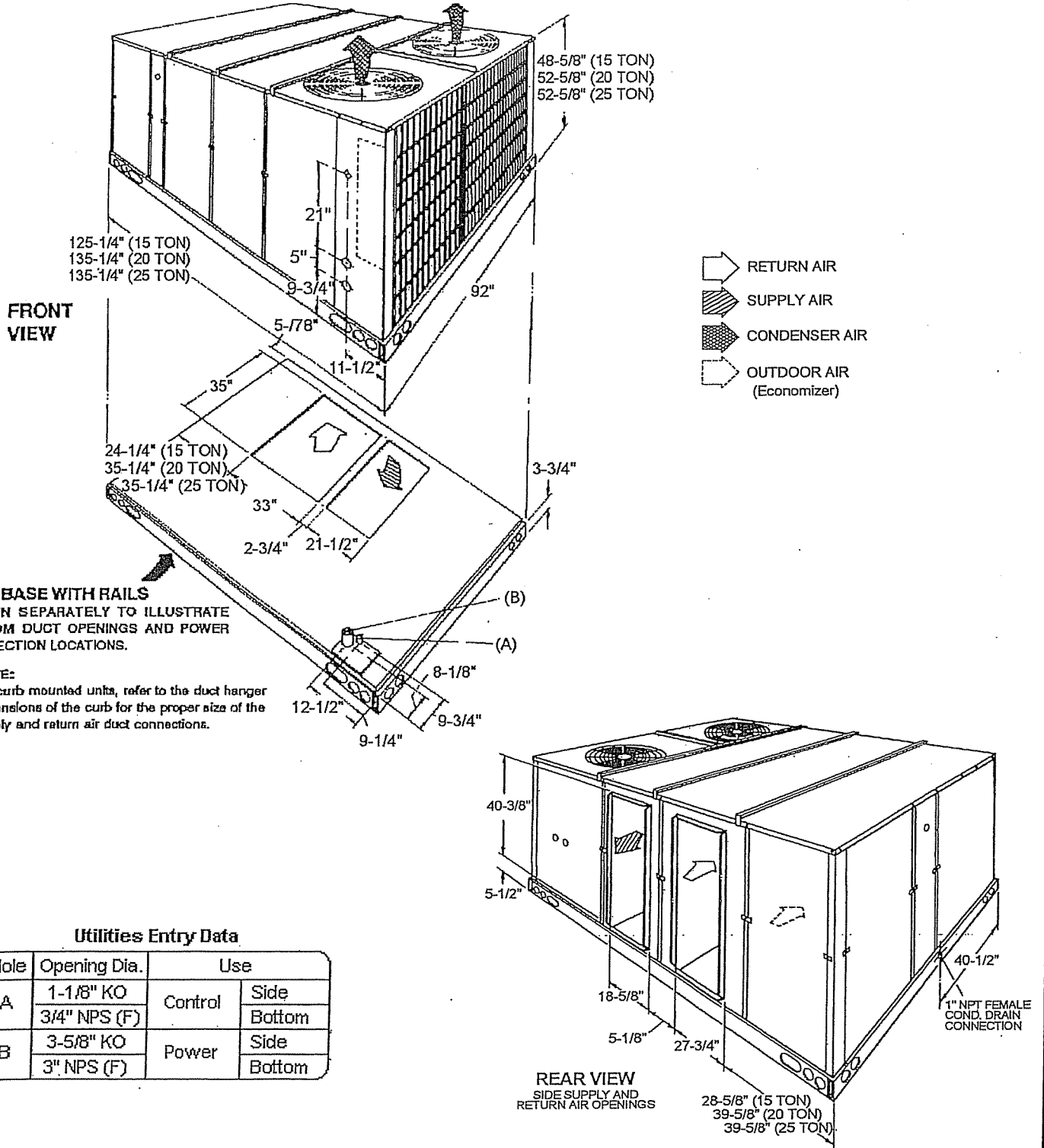

Utilities Entry Data

Hole	Opening Dia.	Use	
A	1-1/8" KO	Control	Side
	3/4" NPS (F)		Bottom
B	3-5/8" KO	Power	Side
	3" NPS (F)		Bottom

FACTORY INSTALLED OPTIONS

- | | | |
|--|---|---|
| <input checked="" type="checkbox"/> SINGLE ENTHALPY ECONOMIZER | <input type="checkbox"/> POWER EXHAUST | <input type="checkbox"/> NOVAR CONTROLS |
| <input type="checkbox"/> BAS READY ECONOMIZER | <input checked="" type="checkbox"/> HIGH STATIC DRIVE | <input checked="" type="checkbox"/> JOHNSON CONTROLS |
| <input type="checkbox"/> MOTORIZED 100% OUTDOOR AIR DAMPER | <input checked="" type="checkbox"/> AIR PROVING SWITCH | <input type="checkbox"/> HONEYWELL CONTROLS |
| <input checked="" type="checkbox"/> DISCONNECT SWITCH | <input type="checkbox"/> TECHNICOAT CONDENSER COIL | <input type="checkbox"/> CPC CONTROLS |
| <input type="checkbox"/> CONVENIENCE OUTLET (Non-Powered) | <input type="checkbox"/> TECHNICOAT EVAPORATOR COIL | <input type="checkbox"/> INTELLI-COMFORT CONTROLS |
| <input type="checkbox"/> CONVENIENCE OUTLET (Powered) | <input checked="" type="checkbox"/> PHASE MONITOR | <input type="checkbox"/> MODLINC |
| <input type="checkbox"/> 4" FILTERS | <input type="checkbox"/> OUTDOOR COIL GUARD | <input checked="" type="checkbox"/> DIRTY FILTER SWITCH |
| <input type="checkbox"/> 2" PLEATED FILTERS | <input checked="" type="checkbox"/> HINGED FILTER DOOR & TOOL-LESS ACCESS | <input type="checkbox"/> SUPPLY AIR SMOKE DETECTOR |
| <input type="checkbox"/> STAINLESS STEEL GAS HEAT EXCHANGER | <input type="checkbox"/> REFRIGERANT REHEAT COIL | <input type="checkbox"/> RETURN AIR SMOKE DETECTOR |
| <input type="checkbox"/> ELECTRIC HEAT | | <input type="checkbox"/> OVERSIZED BLOWER MOTOR |
| | | <input type="checkbox"/> LOW STATIC MOTOR & DRIVE |
| | | <input type="checkbox"/> DOUBLE WALL CONSTRUCTION |
| | | <input type="checkbox"/> 2-ROW DEEP HEAT RECLAIM COIL |
| | | <input type="checkbox"/> 3-ROW DEEP HEAT RECLAIM COIL |

FIELD INSTALLED ACCESSORIES

- | | | |
|--|--|--|
| <input type="checkbox"/> SINGLE ENTHALPY ECONOMIZER | <input type="checkbox"/> SIMPLICITY WIRELESS | <input type="checkbox"/> DIRTY FILTER SWITCH |
| <input type="checkbox"/> DUAL ENTHALPY SENSOR | <input type="checkbox"/> SIMPLICITY REPEATER | <input checked="" type="checkbox"/> BAROMETRIC RELIEF DAMPER |
| <input type="checkbox"/> MOTORIZED 100% OUTDOOR AIR DAMPER | <input type="checkbox"/> SIMPLICITY TRANSPORTER | <input type="checkbox"/> PROPANE CONVERSION KIT |
| <input checked="" type="checkbox"/> ECONOMIZER RAIN HOOD | <input type="checkbox"/> AIR PROVING SWITCH | <input type="checkbox"/> NATURAL GAS HIGH ALTITUDE KIT |
| <input type="checkbox"/> SIDE DUCT FLANGES | <input type="checkbox"/> RETURN AIR HUMIDITY SENSOR | <input type="checkbox"/> PROPANE GAS HIGH ALTITUDE KIT |
| <input type="checkbox"/> CO2 SENSOR | <input type="checkbox"/> FREEnet SERIAL ADAPTER | <input type="checkbox"/> ZONE CONTROLS |
| <input type="checkbox"/> HIGH STATIC DRIVE | <input type="checkbox"/> FREEnet USB ADAPTER | <input type="checkbox"/> WOOD SKID |
| <input type="checkbox"/> EXHAUST EXTENSION KIT | <input type="checkbox"/> WALL SENSOR | <input type="checkbox"/> ENERGY RECOVERY VENTILATOR |
| <input type="checkbox"/> OUTDOOR COIL GUARD | <input type="checkbox"/> WALL SENSOR w/ Override | <input type="checkbox"/> ERV SUPPORT PIER |
| <input type="checkbox"/> HAIL GUARD | <input type="checkbox"/> WALL SENSOR w/ Setpoint Adj. & Override | <input type="checkbox"/> ERV BALANCING DAMPER |
| <input type="checkbox"/> 14" HIGH ROOF CURB | <input type="checkbox"/> DEHUMIDISTAT | <input type="checkbox"/> SUPPLY AIR SMOKE DETECTOR |
| <input type="checkbox"/> 24" HIGH ROOF CURB | | <input type="checkbox"/> RETURN AIR SMOKE DETECTOR |
| <input type="checkbox"/> BURGLAR BARS | | |
| <input type="checkbox"/> THERMOSTAT | | |



UNITS WITH ECONOMIZER & FIXED OUTDOOR AIR HOOD

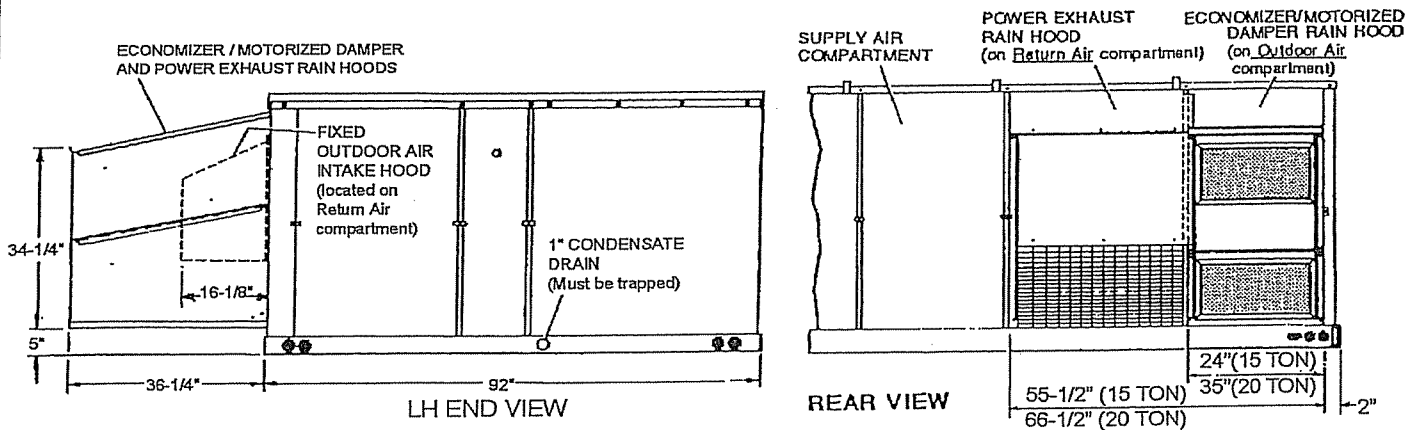

Notes:

GUIDE SPECIFICATIONS

GENERAL

Units shall be manufactured by York International Unitary Products Group in an ISO 9001 certified facility.

York's Sunline 2000™ units are convertible single package units. All models have dual independent refrigerant circuits for efficient part load operation and maximum comfort control. Although the units are primarily designed for curb mounting on a roof, they can also be slab-mounted at ground level or set on steel beams above a finished roof. Cooling only, cooling with gas heat and cooling with electric heat models are available with a wide variety of factory-mounted options and field-installed accessories to make them suitable for almost every application. All units are self-contained and assembled on full perimeter base rails with holes in the four corners for overhead rigging. Every unit is completely piped, wired, charged and tested at the factory to simplify the field installation and to provide years of dependable operation. All models (including those with an economizer) are suitable for either bottom or horizontal duct connections. Models with power exhaust are suitable for bottom duct connections only. For bottom duct, remove the sheet metal panels from the supply and return air openings through the base of the unit. For horizontal duct, replace the supply and return air panels on the rear of the unit with a side duct flange accessory. All supply air blowers are equipped with a belt drive that can be adjusted to meet the exact requirements of the job.

Each unit shall have 2 condenser fan motors. A high speed drive accessory is available for applications with a higher CFM and/or static pressure requirement. All compressors include crankcase heat and internal pressure relief. Every refrigerant circuit includes an expansion valve, a liquid line filter-drier, a discharge line high pressure switch and a suction line with a freestat and low pressure/loss of charge switch. The unit control circuit includes a 75 VA transformer, a 24-volt circuit breaker and a relay board with two compressor lockout circuits, a terminal strip for thermostat wiring, plus an additional set of pin connectors to simplify the interface of additional field controls. All units have long lasting powder paint cabinets with 1000 hour salt spray test approval under ASTM-B117 procedures. All models are CSA approved. All models include a 1-year limited warranty on the complete unit. Compressors and electric heater elements carry an additional 4-year warranty. Aluminized steel tubular heat exchangers carry an additional 9-year warranty.

DESCRIPTION

Units shall be factory-assembled, single packaged, DM***N Electric Cooling/Gas Heat, DM***C/E Electric Cooling/Optional Electric Heat, designed for outdoor mounted installation. The 15, 20 and 25 ton units shall have minimum EER ratings of 8.5.

They shall have built-in field convertible duct connections for down discharge supply/return or horizontal discharge supply/return, and be available with factory installed options or field installed accessories. The units shall be factory wired, piped, charged with R-22 refrigerant and factory tested prior to ship-

ment. All unit wiring shall be both numbered and color coded. All units shall be manufactured in a facility certified to ISO 9001 standards and the cooling performance shall be rated in accordance with DOE and ARI test procedures. Units shall be CGA listed, classified to ANSI Z21.47 standards, UL 1995/CAN/CSA No. 236-M90 conditions.

UNIT CABINET

Unit cabinet shall be constructed of G90 galvanized steel, with exterior surfaces coated with a non-chalking, powdered paint finish, certified at 1000 hours salt spray test per ASTM-B117 standards. Indoor blower section shall be insulated with a minimum 1/2" thick insulation, coated on the airside. Aluminum foil faced insulation shall be used in the furnace compartment and be fastened with ridged fasteners to prevent insulation from entering the air stream. Cabinet panels shall be "large" size, easily removable for servicing and maintenance. Full perimeter base rails shall be provided to assure reliable transit of equipment, overhead rigging and proper sealing on roof curb applications. Disposable 2" filters shall be furnished and be accessible through a removable access door, sealed airtight. Units filter track shall be designed to accommodate either 2" or 4" filters. Fan performance measuring ports shall be provided on the outside of the cabinet to allow accurate air measurements of evaporator fan performance without removing panels or creating air by-pass of the coils. Condensate pan shall be internally sloped and conform to ASHRAE 62-89 self-draining standards. Condensate connection shall be a minimum of 1" I.D. female and be a ridged mount connection. Unit shall incorporate a fixed outdoor air damper with an outdoor air intake opening covered with a bird screen and a rain hood painted to match the exterior of the unit.

INDOOR (EVAPORATOR) FAN ASSEMBLY

Fan shall be a belt drive assembly and include an adjustable-pitch motor pulley. Job site selected (B.H.P.) brake horsepower shall not exceed the motors nameplate horsepower rating, plus the service factor. Units shall be designed not to operate above service factor. Fan wheel shall be double-inlet type with forward-curved blades, dynamically balanced to operate smoothly throughout the entire range of operation. Airflow design shall be constant air volume.

OUTDOOR (CONDENSER) FAN ASSEMBLY

The outdoor fans shall be of the direct-driven propeller type, discharge air vertically, have aluminum blades riveted to corrosion resistant steel spider brackets and shall be dynamically balanced for smooth operation. The 2 outdoor fan motors shall be totally enclosed with permanently lubricated bearings, internally protected against overload conditions and staged independently.

REFRIGERANT COMPONENTS

Compressors:

- a. Shall be Scroll (25T only) compressors internally protected with internal high-pressure relief and over temperature protection.

- b. Shall have internal spring isolation and sound muffling to minimize vibration and noise, and be externally isolated on a dedicated, independent mounting.

Coils:

- a. Evaporator and condenser coils shall have aluminum plate fins mechanically bonded to seamless internally enhanced copper tubes with all joints brazed. Special Phenolic coating shall be available as a factory option.
- b. Evaporator and Condenser coils shall be of the direct expansion, draw-thru, design.

Refrigerant Circuit and Refrigerant Safety Components shall include:

- a. Balance-port thermostatic expansion valve with independent circuit feed system.
- b. Filter drier/strainer to eliminate any moisture or foreign matter.
- c. Accessible service gage connections on both suction and discharge lines to charge, evacuate, and measure refrigerant pressure during any necessary servicing or troubleshooting, without losing charge.
- d. The refrigeration system shall provide at least 15° F of sub-cooling at design conditions.
- e. All models shall have two independent circuits.

UNIT CONTROLS

- a. Unit shall be complete with self-contained low-voltage control circuit protected by a resettable circuit breaker on the 24-volt transformer side.
- b. Unit shall incorporate a lockout circuit which provides reset capability at the space thermostat or base unit, should any of the following standard safety devices trip and shut off compressor.
- c. Loss-of-charge/Low-pressure switch.
 1. High-pressure switch.
 2. Freeze-protection thermostat, evaporator coil. If any of the above safety devices trip, a LED (light-emitting diode) indicator shall flash a diagnostic code that indicates which safety switch has tripped.
- d. Unit shall incorporate "AUTO RESET" compressor over temperature, over current protection.
- e. Unit shall operate with conventional thermostat designs and have a low voltage terminal strip for easy hook-up.
- f. Unit control board shall have on-board diagnostics and fault code display.
- g. Standard controls shall include anti-short cycle and low voltage protection, and permit cooling operation down to 0 °F.

- h. Control board shall monitor each refrigerant safety switch independently.
- i. Control board shall retain last 5 fault codes in non volatile memory, which will not be lost in the event of a power loss.

GAS HEATING SECTION (DM***N MODELS)

Shall be designed with induced draft combustion with post purge logic and energy saving direct spark ignition, redundant main gas valve. Ventor wheel shall be constructed of stainless steel for corrosion resistance. The heat exchanger shall be of the tubular type, constructed of T1-40 aluminized steel for corrosion resistance and allowing minimum mixed air entering temperature of 25° F. Burners shall be of the in-shot type, constructed of aluminum coated steel and contain air mixture adjustments. All gas piping shall enter the unit cabinet at a single location through either the side or curb, without any field modifications. An integrated control board shall provide timed control of evaporator fan functioning and burner ignition. Heating section shall be provided with the following minimum protection:

- a. Primary and auxiliary high-temperature limit switches.
- b. Induced draft motor speed sensor.
- c. Flame roll out switch (automatic reset).
- d. Flame proving controls. Unit shall have two independent stages of capacity.

~~ELECTRIC HEATING (DM**C/E MODELS)~~

~~Nickel chromium electric heating elements shall be provided as required by the application with 1 or 2 stage control, as required, from 13.5 KW to 72 KW capacities. The heating section shall have a primary limit control(s) and automatic reset to prevent the heating element system from operating at an excessive temperature. Units with Electric Heating shall be wired for a single point power supply with branch circuit fusing (where required).~~

UNIT OPERATING CHARACTERISTICS

Unit shall be capable of starting and running at 125° F outdoor temperature, exceeding maximum load criteria of ARI Standard 340/360. The compressor, with standard controls, shall be capable of operation down to 0° F outdoor temperature. Unit shall be provided with fan time delay to prevent cold air delivery before heat exchanger warms up (Gas heat only).

ELECTRICAL REQUIREMENTS

All unit power wiring shall enter unit cabinet at a single factory provided location and be capable of side or bottom entry, to minimize roof penetrations and avoid unit field modifications. Separate side and bottom openings shall be provided for the control wiring.

STANDARD LIMITED WARRANTIES

- Compressor 5 Years
- Heat Exchanger 10 Years

262259-YTG-A-0706

~~Electric Heat Element 5 Years~~

- Other Parts 1 Year

OPTIONAL OUTDOOR AIR (Shall be made available by either/or):

- **ELECTRONIC ENTHALPY AUTOMATIC ECONOMIZER** - Outdoor and return air dampers that are interlocked and positioned by a fully-modulating, spring-return damper actuator. The maximum leakage rate for the outdoor air intake dampers shall not exceed 2% when dampers are fully closed and operating against a pressure differential of 0.5 IWG. A unit-mounted potentiometer shall be provided to adjust the outdoor and return air damper assembly to take in CFM of outdoor air to meet the minimum ventilation requirement of the conditioned space during normal operation. During economizer operation, a mixed-air temperature control shall modulate the outdoor and return air damper assembly to prevent the supply air temperature from dropping below 55°F. Changeover from compressor to economizer operation shall be provided by an integral electronic enthalpy control that feeds input into the basic module. The outdoor intake opening shall be covered with a rain hood that matches the exterior of the unit. Water eliminator/filters shall be provided. Simultaneous economizer/compressor operation is also possible. Dampers shall fully close on power loss.

- ~~**MOTORIZED OUTDOOR AIR DAMPERS** - Outdoor and return air dampers that are interlocked and positioned by a 2-position, spring-return damper actuator. The maximum leakage rate for the outdoor air intake dampers shall not exceed 2% when dampers are fully closed and operating against a pressure differential of 0.5 IWG. A unit-mounted potentiometer shall be provided to adjust the outdoor and return air damper assembly to take in the design CFM of outdoor air to meet the ventilation requirements of the conditioned space during normal operation. Whenever the indoor fan motor is energized, the dampers open up to one of two pre-selected positions - regardless of the outdoor air enthalpy. Dampers return to the fully closed position when the indoor fan motor is de-energized. Dampers shall fully close on power loss.~~

OTHER PRE-ENGINEERED ACCESSORIES AVAILABLE

- **ROOF CURB** - 14" high, full perimeter curb with wood nailer (shipped knocked-down).
- **100% BAROMETRIC RELIEF DAMPER** - Contains a rain hood, air inlet screen, exhaust damper and mounting hardware. Used to relieve internal air pressure through the unit.
- **PROPANE CONVERSION KIT** - Contains new orifices and gas valve parts to convert from natural to L.P. gas. One per unit required.

- **HIGH ALTITUDE - NATURAL GAS** - Contains orifices required for applications between 2000 and 6000 feet altitude.
- **HIGH ALTITUDE - PROPANE GAS** - Contains orifices required for applications between 2000 and 6000 feet altitude. Must be used with propane conversion kit.
- **BURGLAR BARS** - Designed to work with above roof curbs, depending on unit model. Fits duct openings of curb supply and return air openings.
- **SIDE DUCT FLANGE** - Supply and return air duct flanges for side duct applications. Do not use on units with power exhaust.
- **HIGH SPEED DRIVE** - Includes blower pulley and belt for higher CFM and/or static pressure requirements.
- **WOOD SKID** - Allows unit to be handled with 90" forks.
- **ECONOMIZER/MOTORIZED DAMPER RAIN HOOD (DMN/E/C300 only)** - Contains all hood panels and the hardware for assembling.
- **ANTI-RECYCLE TIMER** - Assures 5-minute off time between compressor cycles.
- **COIL GUARD KIT** - Guard for cooling coil.

OTHER FACTORY INSTALLED OPTIONS

- **POWER EXHAUST OPTION** - To work in conjunction with economizers.
- **STAINLESS STEEL HEAT EXCHANGER**
- **STAINLESS STEEL DRAIN PAN**
- **TECHNICOAT PHENOLIC COATED CONDENSER AND EVAPORATOR COIL**
- **ELECTRONIC SINGLE ENTHALPY ECONOMIZER**
- **DIRTY FILTER SWITCH**
- **PHASE MONITOR**
- **COIL GUARD**
- **POWERED GFI CONVENIENCE OUTLET**
- **NON-POWERED GFI CONVENIENCE OUTLET**
- **BAS CONTROLS (Simplicity® INTELLI-Comfort™ CPC, JOHNSON, HONEYWELL, NOVAR)**
- **BAS READY ECONOMIZER (BELIMO ACTUATOR WITHOUT A CONTROLLER)**
- **HINGED FILTER DOOR ACCESS AND TOOLESS ACCESS PANELS**
- **HIGH SPEED DRIVE**
- **2" THROW AWAY FILTERS**
- **4" PLEATED FILTERS**
- **DISCONNECT SWITCH**
- **SUPPLY AIR SMOKE DETECTOR**
- **RETURN AIR SMOKE DETECTOR**

AFFIDAVIT

West Virginia Code §5A-3-10a states:

No contract or renewal of any contract may be awarded by the state or any of its political subdivisions to any vendor or prospective vendor when the vendor or prospective vendor or a related party to the vendor or prospective vendor is a debtor and the debt owned is an amount greater than one thousand dollars in the aggregate

DEFINITIONS:

"Debt" means any assessment, premium, penalty, fine, tax or other amount of money owed to the state or any of its political subdivisions because of a judgment, fine, permit violation, license assessment, defaulted workers' compensation premium, penalty or other assessment presently delinquent or due and required to be paid to the state or any of its political subdivisions, including any interest or additional penalties accrued thereon.

"Debtor" means any individual, corporation, partnership, association, limited liability company or any other form or business association owing a debt to the state or any of its political subdivisions. "Political subdivision" means any county commission; municipality; county board of education; any instrumentality established by a county or municipality; any separate corporation or instrumentality established by one or more counties or municipalities, as permitted by law; or any public body charged by law with the performance of a government function or whose jurisdiction is coextensive with one or more counties or municipalities. "Related party" means a party, whether an individual, corporation, partnership, association, limited liability company or any other form or business association or other entity whatsoever, related to any vendor by blood, marriage, ownership or contract through which the party has a relationship of ownership or other interest with the vendor so that the party will actually or by effect receive or control a portion of the benefit, profit or other consideration from performance of a vendor contract with the party receiving an amount that meets or exceed five percent of the total contract amount.

EXCEPTION:

The prohibition of this section does not apply where a vendor has contested any tax administered pursuant to chapter eleven of this code, workers' compensation premium, permit fee or environmental fee or assessment and the matter has not become final or where the vendor has entered into a payment plan or agreement and the vendor is not in default of any of the provisions of such plan or agreement.

LICENSING:

Vendors must be licensed and in good standing in accordance with any and all state and local laws and requirements by any state or local agency of West Virginia, including, but not limited to, the West Virginia Secretary of State's Office, the West Virginia Tax Department, West Virginia Insurance Commission, or any other state agencies or political subdivision. Furthermore, the vendor must provide all necessary releases to obtain information to enable the Director or spending unit to verify that the vendor is licensed and in good standing with the above entities.

CONFIDENTIALITY:

The vendor agrees that he or she will not disclose to anyone, directly or indirectly, any such personally identifiable information or other confidential information gained from the agency, unless the individual who is the subject of the information consents to the disclosure in writing or the disclosure is made pursuant to the agency's policies, procedures and rules. Vendors should visit www.state.wv.us/admin/purchase/privacy for the Notice of Agency Confidentiality Policies.

Under penalty of law for false swearing (West Virginia Code, §61-5-3), it is hereby certified that the vendor acknowledges the information in this said affidavit and are in compliance with the requirements as stated.

Vendor's Name: _____

Authorized Signature: _____ Date: _____