



The following documentation is an electronically-submitted vendor response to an advertised solicitation from the *West Virginia Purchasing Bulletin* within the Vendor Self-Service portal at wvOASIS.gov. As part of the State of West Virginia's procurement process, and to maintain the transparency of the bid-opening process, this documentation submitted online is publicly posted by the West Virginia Purchasing Division at WVPurchasing.gov with any other vendor responses to this solicitation submitted to the Purchasing Division in hard copy format.

Header 5

List View

General Information | Contact | Default Values | Discount | Document Information | Clarification Request

Procurement Folder: 1919880
 Procurement Type: Central Purchase Order
 Vendor ID: 000000203432
 Legal Name: DOUGLAS FOOD STORES INC
 Alias/DBA: DOUGLAS EQUIPMENT
 Total Bid: \$36,345.24
 Response Date: 05/27/2026
 Response Time: 11:19
 Responded By User ID: rbergin1
 First Name: Rebecca
 Last Name: Bergin
 Email: rebecca@douglosequipmer
 Phone: 304-327-0149

SO Doc Code: CRFQ
 SO Dept: 0603
 SO Doc ID: ADJ2600000021
 Published Date: 5/20/26
 Close Date: 5/27/26
 Close Time: 13:30
 Status: Closed
 Solicitation Description: Ovens for Mountaineer Challenge Academy Dining Facility
 Total of Header Attachments: 5
 Total of All Attachments: 5



Department of Administration
 Purchasing Division
 2019 Washington Street East
 Post Office Box 50130
 Charleston, WV 25305-0130

**State of West Virginia
 Solicitation Response**

Proc Folder: 1919880
Solicitation Description: Ovens for Mountaineer Challenge Academy Dining Facility
Proc Type: Central Purchase Order

Solicitation Closes	Solicitation Response	Version
2026-05-27 13:30	SR 0603 ESR05272600000008246	1

VENDOR
 000000203432
 DOUGLAS FOOD STORES INC

Solicitation Number: CRFQ 0603 ADJ2600000021
Total Bid: 36345.23999999999796273186802 **Response Date:** 2026-05-27 **Response Time:** 11:19:50
Comments:

FOR INFORMATION CONTACT THE BUYER
 David H Pauline
 304-558-0067
 david.h.pauline@wv.gov

Vendor Signature X **FEIN#** **DATE**

All offers subject to all terms and conditions contained in this solicitation

Line	Comm Ln Desc	Qty	Unit Issue	Unit Price	Ln Total Or Contract Amount
1	Gas Combi Ovens	2.00000	EA	18172.620000	36345.24

Comm Code	Manufacturer	Specification	Model #
48101507			

Commodity Line Comments: Units are in stock currently otherwise its 14-16 week lead time.

Extended Description:

Please refer to the Exhibit "A" Pricing Page to input unit pricing.

Project:
26-7451 Mountaineer Challenge
Academy Camp Dawson

From:
Douglas Equipment
Samantha Radford
301 North St.
Bluefield , WV 24701-4048
304-327-0149

Job Reference Number: 176642

PLEASE INCLUDE QUOTE WHEN SENDING IN PO

Please check quotation carefully. If an accessory is not standard and is not listed, it will not be provided.

Standard Manufacturer's warranty implied unless stated otherwise. It is the dealer/contractor's responsibility to provide any additional warranty required.

Item	Qty	Description	Sell	Sell Total
1	2 ea	COMBI OVEN, GAS Convotherm Model No. C4 ET 6.20GS-N Convotherm Maxx Pro Combi Oven/Steamer, gas, boilerless, (6) 18" x 26" full size sheet pan or (12) 12" x 20" x 1" hotel pan capacity, 10" wifi-ready, high resolution easyTouch control panel, 20 stages each & 399 cooking recipes storage, (4) cooking modes: hot air, steam, combi-steam & retherm, LED light, triple pane right hinged door with anti-microbial hygienic door handle, multi-point core temperature probe, five-speed auto reversing fan, includes (3) wire shelves, pull-out spray hose, ConvoClean+ fully automatic hands-free cleaning system, stainless steel construction, 0.5kW, 120v/60/1-ph, 7.5 amps, 68,200 BTU, cULus, NSF, ENERGY STAR®	\$14,537.33	\$29,074.66
	2 ea	NOTE: Purchasers, owners & operators are solely responsible to verify that the incoming water to the equipment is within the manufacturer's water quality specs as outlined on the product spec sheet. Water quality verification in virtually all cases requires water testing & in some cases, requires that water samples be submitted & for which the test results may take 4 weeks to receive. Non-compliance with manufacturer water quality specifications can cause irreparable damage to the equipment & /		



Item	Qty	Description	Sell	Sell Total
		or its components & will VOID the original manufacturer's warranty. Water treatment solutions shown on this page & in the pricelist are offered for purchasing convenience only & can be selected only if the incoming water quality falls within the water treatment manufacturer's selection guidelines.		
	2 ea	2 years parts & labor warranty (requires registration at convotherm.com), standard		
	2 ea	FAS START UP Mechanical start up for (1) Convotherm oven by Convotherm authorized servicer is included with oven purchase within 200 miles (round-trip), additional charges will apply outside of this range		
	2 ea	C-START Cleaner Kit, Includes: One (1) 2.5 Gallon container of ConvoClean forte solution, One (1) 2.5 Gallon container of ConvoCare solution & a set of connectors and hoses		
	1 ea	11000115830 Convotherm Pre-installation site survey required per location when purchasing Convotherm Certified Installation Program (Non-discountable NET pricing) (Includes 200 mile round trip, Continental USA only, additional charges may apply, see Installation flyer for details)	\$500.00	\$500.00
	1 ea	11000115826 Installation of First Unit, for 6.10, 6.20, 10.10 & 10.20 (Non-discountable NET pricing) (Note: Pricing based on 200 mile round trip, additional charges may apply, see Installation flyer for details) (Note: Customer should indicate your preferred Welbilt Authorized Service Agent for installation on the PO otherwise Welbilt RISE will select an Authorized Service Agent for this install) (Mainland U.S.)	\$1,375.00	\$1,375.00
	2 ea	New Construction		
	2 ea	Note: End user contact name & number at the site must be included with the PO to avoid delivery delays. This contact person should have up-to-the-minute status on water, drain, electric/gas availability, as well as confirmation of completion of interior & exterior doorways through which equipment must be transported.		
	1 ea	11000115827 Installation of each additional unit, for 6.10, 6.20, 10.10 & 10.20 (at the same location & at the same time) (Non-discountable NET pricing) (Note: Pricing based on 200 mile round trip, additional charges may apply, see Installation flyer for details) (Note: Customer should indicate your preferred Welbilt Authorized Service Agent for installation on the PO otherwise Welbilt RISE will select an Authorized Service Agent for this install) (Mainland U.S.)	\$1,100.00	\$1,100.00
	2 kt	11000115805 Installation Kits (one per combi), for 6.10, 6.20 & 10.10 gas, DWV Copper (Non-discountable NET pricing) (See Installation Kit flyer for details)	\$722.00	\$1,444.00

Item	Qty	Description	Sell	Sell Total
	2 ea	11000115833 Water Filtration Installation for Convotherm (only for filtration systems purchased with equipment and thru Convotherm) (Non-discountable NET pricing) (Includes 200 mile round trip, Mainland U.S., additional charges may apply, see Installation flyer for details)	\$275.00	\$550.00
	1 kt	11000115831 Convotherm 4 Stacking Kit Installation (per stack) (Non-discountable NET pricing) (Note: Pricing based on 200 mile round trip, additional charges may apply, see Installation flyer for details) (Note: Customer should indicate your preferred Welbilt Authorized Service Agent for installation on the PO otherwise Welbilt RISE will select an Authorized Service Agent for this install) (Mainland U.S.)	\$250.00	\$250.00
	2 ea	Natural Gas		
	2 ea	Door hinged right, standard		
	2 ea	ECP External Core Probe, with external socket (built in probe standard)	\$342.69	<Optional>
	6 ea	CWR20 Wire Shelf, 20" x 26", stainless steel, for 6.20, 10.20, 12.20 & 20.20 (P/N 3001085)	\$73.24	<Optional>
	6 ea	CWB20 Frying Basket, Wire, 20" x 26"	\$122.62	<Optional>
	2 ea	An RO system must be included on this quote if mail-in water test results have not been received by the dealer PRIOR to creating this quote. A filter system should only be included on this quote if water test results are in hand & the test results indicate a water filter meets the water specification.		
	2 ea	FLT0039-COV Water treatment system, dual-cartridge, with (2) Qwik-Twist cartridges, 0.5-microns sediment reduction, reduces chlorine, taste & odor at a flow rate of 2.5 gpm for 20,000-gallons & chloramine at a flow rate of 0.5 gpm for up to 6,000-gallons. pressure gauge, inlet shut-off valve, mounting bracket, for use with steam & combi ovens. (Non-discountable NET)	\$249.11	\$498.22
	1 kt	3456277 Stacking Kit, for 6.20 on 6.20 with 12" base (gas models) (NOTE: 12 inch leg is recommended. Only use the 6 inch leg in cases where the hood height is too low to accommodate a 12 inch leg)	\$1,553.36	\$1,553.36
			ITEM TOTAL:	\$36,345.24
			Total	\$36,345.24

- BID ALL OR NOTHING
- PRICING VALID FOR 30 DAYS
- PLEASE ADD 3% FOR CREDIT CARD PURCHASES
- DOES NOT INCLUDE STATE SALES TAX WHERE APPLICABLE
- SHIPPING INCLUDED BASED OFF OF THE QUANTITY AND LOCATION REQUESTED.
- IF ORDER REFLECTS A DIFFERENT QUANTITY OR LOCATION, PRICE IS SUBJECT TO CHANGE AT CUSTOMERS EXPENSE.*

Lead time units currently in stock 1-2 weeks / other wise 14-16 weeks

- Installation is included in the unit pricing.
- The customer is responsible for confirming all electrical voltages & phases on each unit quoted.
- The customer is responsible for all power supplies and utilities to be within four feet of the install footprint and to match the utility requirements of the units being installed prior to the installer’s arrival.
- The installer will be hooking up the new equipment to ALREADY EXISTING utilities.
- The site MUST be ready upon installer’s arrival; if it is not, or the installer has to make a second trip, more charges will incur and be the responsibility of the customer.
- We are not responsible for any utility upgrades or architectural modifications if they become necessary.
- This job is being bid site unseen; if the installer, upon arrival, deems that more work is necessary than a standard install, more charges will incur and be the responsibility of the customer. It is assumed that no stairs or doorways will need to be traversed.
- This work is to be done during normal hours, Monday – Friday, 8:00 am – 5:00 pm, holidays excluded.

Acceptance: _____ Date: _____

Printed Name: _____

Project Grand Total: \$36,345.24



Combi oven

Project _____
 Item _____
 Quantity _____
 FCSI section _____
 Approval _____
 Date _____

Convotherm maxx pro easyTouch

- 6.20
- 7 slide rails
- Gas
- Injection/Spritzer
- Right-hinged door



Key Features

- Advanced Closed System+ (ACS+) cooking methods: Steam, combi-steam, hot air
- Advanced Closed System+ (ACS+) with extra functions:
 - Crisp&Tasty - 5 moisture-removal settings
 - BakePro - 5 levels of traditional baking
 - HumidityPro - 5 humidity settings
 - Controllable fan - 5 speed settings
- easyTouch 10" TFT high-resolution glass touch display (capacitive)
- ConvoClean+ fully automatic cleaning system with eco, regular and express modes - with optional single-dose dispensing
- HygieniCare
- WiFi and Ethernet port (LAN)
- TriColor indicator ring - indicates the current operating status
- Steam generated by injecting water into the cooking chamber
- LED illumination for cooking chamber
- Triple-glazed right-hinged unit door

Standard features

- Cooking methods:
 - Steam (86-266°F) with guaranteed steam saturation
 - Combi-steam (86-482°F) with automatic humidity adjustment
 - Hot air (86-482°F) with optimized heat transfer
- easyTouch user interface controls:
 - 10" TFT high-resolution glass touch display (capacitive)
 - Smooth-action, quick-reacting scrolling function
- Climate Management
 - Advanced Closed System+ (ACS+), HumidityPro, Crisp&Tasty
- Quality Management
 - Airflow Management, BakePro, multi-point core temperature probe, preheat and cool-down function
- Production Management
 - Automatic cooking with Press&Go with up to 399 profiles
 - Integrated cookbook with 7 different categories
 - TrayTimer - load management for different products simultaneously
 - TrayView - load management for automatic cooking of different products using Press&Go
 - Favorites management
 - HACCP data storage
 - USB port
 - ecoCooking - energy saving function
 - LT cooking (low-temperature cooking) / Delta-T cooking
 - Cook&Hold - cooking and keeping food warm in a single process
 - Auto Start
 - Rethermalization+: versatile multi-mode rethermalization function

Standard features

- Cleaning Management:
 - ConvoClean+: Fully automatic cleaning system
 - Quick access to individually created and stored cleaning profiles
 - Cleaning Scheduler
- HygieniCare:
 - Hygienic Steam Function
 - Hygienic handles
 - SteamDisinfect
- Design:
 - Triple-glazed right-hinged unit door with safety lock, sure-shut function, venting position, and LEDs for illuminating the cooking chamber
 - Steam generated by injecting water into the cooking chamber
 - Adjustable feet with adjustment range between 4 inches and 5 inches
 - Multi-point core temperature probe
 - Integrated recoil hand shower



C4ET 6.20 GS-N



Options

Accessories

C4ET 6.20 GS-N

Convotherm maxx pro easyTouch

- 6.20
- 7 slide rails
- Gas
- Injection/Spritzer
- Right-hinged door

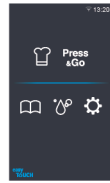

Key Features

- Advanced Closed System+ (ACS+) cooking methods: Steam, combi-steam, hot air
- Advanced Closed System+ (ACS+) with extra functions:
 - Crisp&Tasty - 5 moisture-removal settings
 - BakePro - 5 levels of traditional baking
 - HumidityPro - 5 humidity settings
 - Controllable fan - 5 speed settings
- easyTouch 10" TFT high-resolution glass touch display (capacitive)
- ConvoClean+ fully automatic cleaning system with eco, regular and express modes - with optional single-dose dispensing
- HygieniCare
- WiFi and Ethernet port (LAN)
- TriColor indicator ring - indicates the current operating status
- Steam generated by injecting water into the cooking chamber
- LED illumination for cooking chamber
- Triple-glazed right-hinged unit door

Options

- Triple-glazed disappearing door - more space and added safety (see page 3)
- Quality Management:
 - ConvoSmoke - built in food-smoking (HotSmoke)
 - ConvoGrill with grease management function
- Steam and vapor removal - built-in condenser
- Corrections package
- Available in various voltages
- Sous-vide probe, external connection
- Core temperature probe, external connection (internal core probe standard)

Accessories

- KitchenConnect® (WiFi/LAN), network solution from Welbilt for updating and monitoring appliances from anywhere
- Signal Tower
- Racks
- Banquet system (optionally as a package or individually): Plate rack, mobile shelf rack, transport trolley, thermal cover
- Stacking stands
- Equipment stands in various sizes and designs

Accessories and services by partners

- Cleaning chemicals for the fully automatic ConvoClean+ cleaning system (multiple-dose and single-dose dispensing)
- Water filtration and reverse osmosis systems and replacement filters
- Installation services available - details in AutoQuotes - availability may vary by region
- Cooking, baking, and roasting cookware

9769632_02 ENG_USA 07/23, © 2023 Welbilt. Please note that the product is being continuously improved and that, as a result, these specifications are subject to change without notice.



Dimensions

Weights

Views

Front view

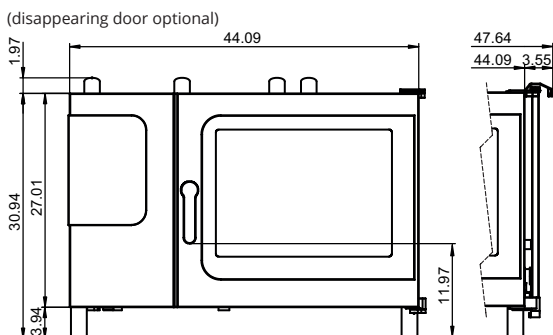

Connection points, bottom of unit

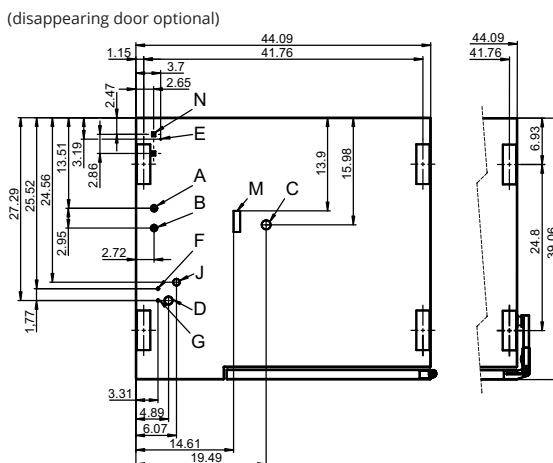

View from above with wall clearances

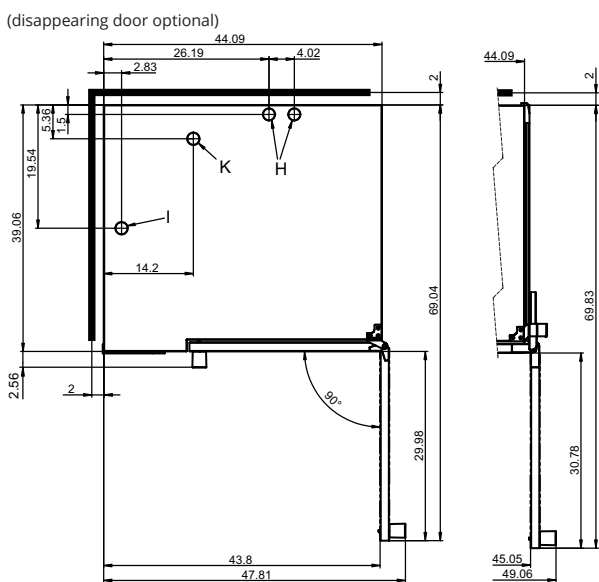

- A Water connection (for water injection)
- B Water connection (for cleaning, recoil hand shower)
- C Drain connection (2" I. D.)
- D Electrical connection
- E Equipotential bonding
- F Rinse-aid connection
- G Cleaning-agent connection
- H Air vent (2" I. D.)
- I Dry air intake (2" I. D.)
- J Gas connection
- K Exhaust outlet (2" I.D.)
- M Safety overflow 3.2" x 1"
- N Ethernet connection RJ45

Dimensions and weights

Dimensions including packaging	
Width x height x depth	53.7" x 41.3" x 45.7"
Weight	
Net weight without options* / accessories	326 lbs
Packaging weight	77 lbs
Safety clearances**	
Rear	2"
Right (right-hinged door)	2"
Right (disappearing door pushed back)	5"
Left (see installation requirements)	2"
Top***	39"

* Max. weight of options: 33 lbs.

** Required for the unit to work properly.

*** Depends on the type of exhaust system and the ceiling's characteristics.

Installation requirements

Clearance from heat sources	min. 20"
Recommended clearance for servicing on the left side of the unit	min. 20"

The combi oven must be easily accessible on three sides in order to ensure accessibility for cleaning. Alternatively, use a 6" foot, available upon request.

C4ET 6.20 GS-N



Capacity

Electrical specifications

Gas

C4ET 6.20 GS-N

Loading capacity

Max. number of food containers [Unit has 7slide rails; rail spacing 2.68" max.]	
Steam table pans (12"x20"x1")	14
Steam table pans (12"x20"x2.5")	14
Wire shelves, full size (20"x26")	7
Sheet pans, full size (18"x26")*	6
Sheet pans, half size (13"x18")*	12
Frying baskets, half size (12"x20")	14
Plates (optional plate rack)	27
Max. loading weight	
Per combi oven	132 lbs
Per shelf level	33 lbs

* Wire shelves required.

Electrical supply

120V 1PH 60Hz *	
Rated power consumption	0.6 kW
Rated current	7.5 A
Power supply wire gauge	14 AWG
Conductor insulation rating	194 °F / 90 °C

* Prepared for connection to an energy optimizing system.

The electrical power supply must be connected to a dedicated permanent supply line. Any ground fault circuit interrupters or residual current devices used must be rated for at least 20mA. Do not connect to residential GFCI outlets, as they will cause nuisance tripping on the device.

Gas specifications

Type of gas	Natural gas, propane
Gas connection	1/2" NPT
Flow pressure	
Natural gas	7" WC
Propane	11" WC
Heat output	For Natural gas, propane
Convection burner	68200 BTU/h

9769632_02 ENG_USA 07/23, © 2023 Welbilt. Please note that the product is being continuously improved and that, as a result, these specifications are subject to change without notice.



Water Emissions

Water connection

Water supply	
Water supply	2 x 3/4" GHT-M garden hose adapter; Alternative, 2 hoses 1/2" inner diameter with one side 3/4" GHT-F to 3/4" BST. The unit is designed for a fixed connection to the water supply using a connecting hose with a minimum inner diameter of 1/2"
Flow pressure	22 - 87 psi / 1.5 - 6 bar
Drain	
Drain version	Naturally ventilated pipe to open pan or drain/channel
Type	2" inner diameter
Slope for drainpipe	min. 3.5% (2°)

Water quality

Water connection A* for water injection	
General requirements	Drinking water, typically treated water (install a water treatment system if necessary)
TDS	70 - 125 ppm
Hardness	70 - 125 ppm (4 - 7 gpg)
Water connection B* for cleaning, recoil hand shower	
General requirements	Drinking water, typically untreated water
TDS	70 - 360 ppm
Hardness	70 - 360 ppm (4 - 21 gpg)
Water connections A, B*	
pH value	6.5 - 8.5
Cl ⁻ (chloride)	max. 60 ppm
Cl ₂ (free chlorine)	max. 0.2 ppm
SO ₄ ²⁻ (sulfate)	max. 150 ppm
Fe (iron)	max. 0.1 ppm
SiO ₂ (silica)	max. 13 ppm
NH ₂ Cl (monochloramine)	max. 0.2 ppm
Temperature	max. 104°F / max. 40°C

* Please refer to the connection points diagram, p. 2.

NOTICE: The owner/operator/purchaser must ensure that the water quality requirements are met. Otherwise the unit warranty is void.

Water consumption

Water connection A*	
Average consumption for cooking	1.4 gph
Max. water throughput	0.2 gpm
Water connections A, B	
Average consumption for cooking**	2.0 gph
Max. water throughput	4.0 gpm

* Values intended as guide for specifying the water treatment system.

** Incl. water required for cooling the wastewater.

NOTICE: See connection positions diagram, p. 2.

Emissions

Heat loss	
Latent	3100 BTU/h
Sensible	4800 BTU/h
Drain temperature	max. 140°F / 60°C
Decibel rating	max. 70 dBA

C4ET 6.20 GS-N



Accessories

ACCESSORIES

(For more detailed information, please refer to the Accessories brochure.)

Stacking kit

Combinations allowed	6.20 on 6.20 6.20 on 10.20
----------------------	-------------------------------

If combining two gas units

Select the "stacking kit for Convotherm 4 gas units"

If combining one electrical unit and one gas unit in a stacking kit

Select the "stacking kit for Convotherm 4 electrical units" if:

Bottom combi oven	EB/ES
-------------------	-------

Top combi oven	GB/GS
----------------	-------

Select the "stacking kit for Convotherm 4 gas units" if:

Bottom combi oven	GB/GS
-------------------	-------

Top combi oven	EB/ES
----------------	-------

Equipment stand

Standard support surface height	26.38"
---------------------------------	--------



Combi Steamer

Project _____
 Item _____
 Quantity _____
 FCSI Section _____
 Approval _____
 Date _____

Stacking Kits - Convotherm 4

Stacking Kits for:

6.10 on 6.10, 6.10 on 10.10,
 6.20 on 6.20, 6.20 on 10.20

- Stainless steel stacking kits for Convotherm 4 models.



Stacking Kits for Electric Models:

Part #	Description	Page
3455861	for 6.10 on 6.10/10.10 with 6" legs (150mm)	2
3456266	for 6.10 on 6.10 with 12" base (300mm)	3
3455864	for 6.20 on 6.20/10.20 with 6" legs (150mm)	4
3456267	for 6.20 on 6.20 with 12" base (300mm)	5

Stacking Kits for Gas Models:

Part #	Description	Page
3456171	for 6.10 on 6.10/10.10 with 6" legs (150mm)	6
3456276	for 6.10 on 6.10 with 12" base (300mm)	7
3456174	for 6.20 on 6.20/10.20 with 6" legs (150mm)	8
3456277	for 6.20 on 6.20 with 12" base (300mm)	9





Dimensions

Weights

Views

Stacking Kits - Convotherm 4

Stacking Kit for stacking electric Convotherm 4 models:

6.10 on 6.10 & 6.10 on 10.10

Part # 3455861

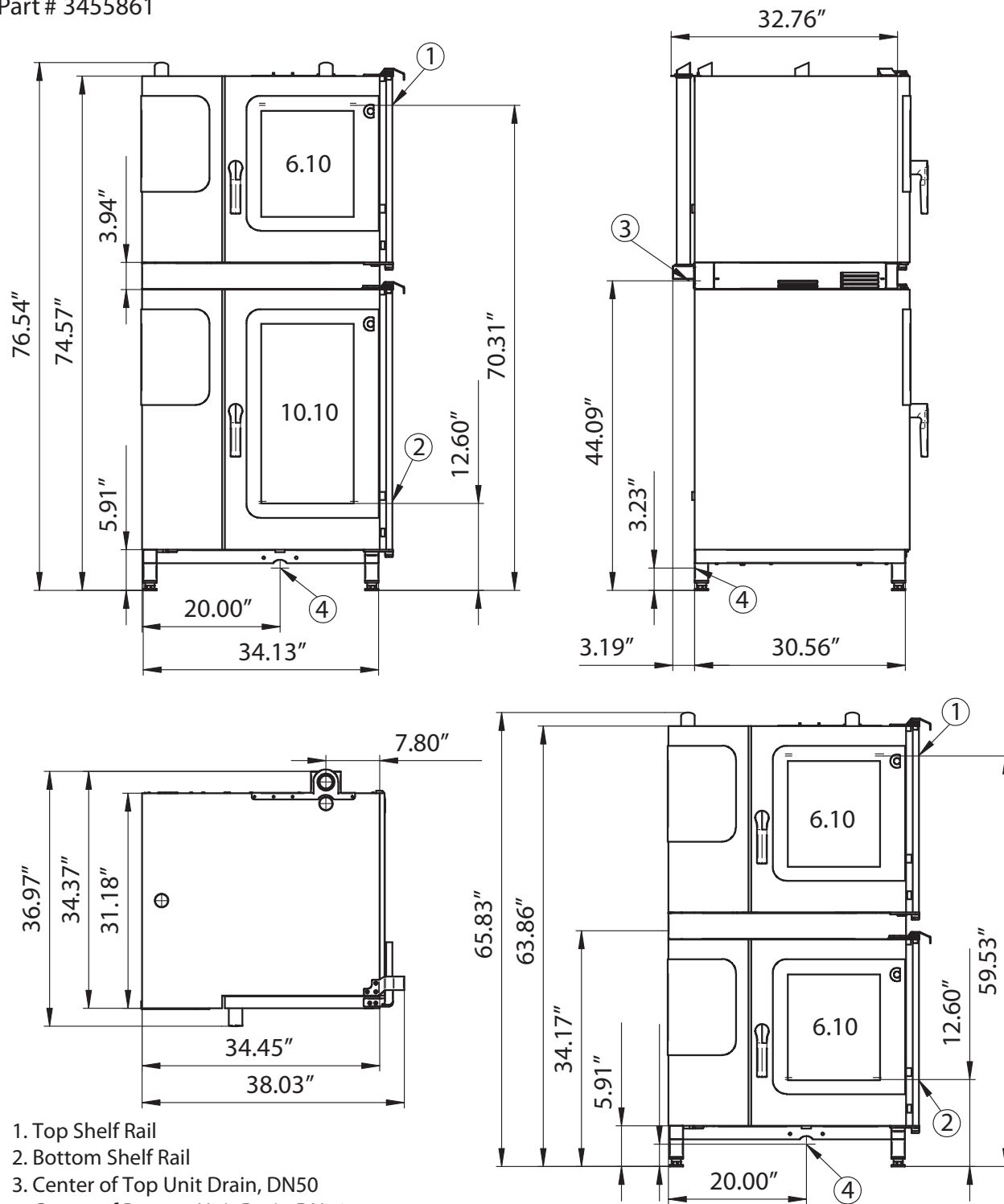

- 1. Top Shelf Rail
- 2. Bottom Shelf Rail
- 3. Center of Top Unit Drain, DN50
- 4. Center of Bottom Unit Drain DN50



Dimensions

Weights

Views

Stacking Kit for stacking two (2) 6.10 electric Convotherm 4 models on a 11" 13/16" high base:

Part # 3456266

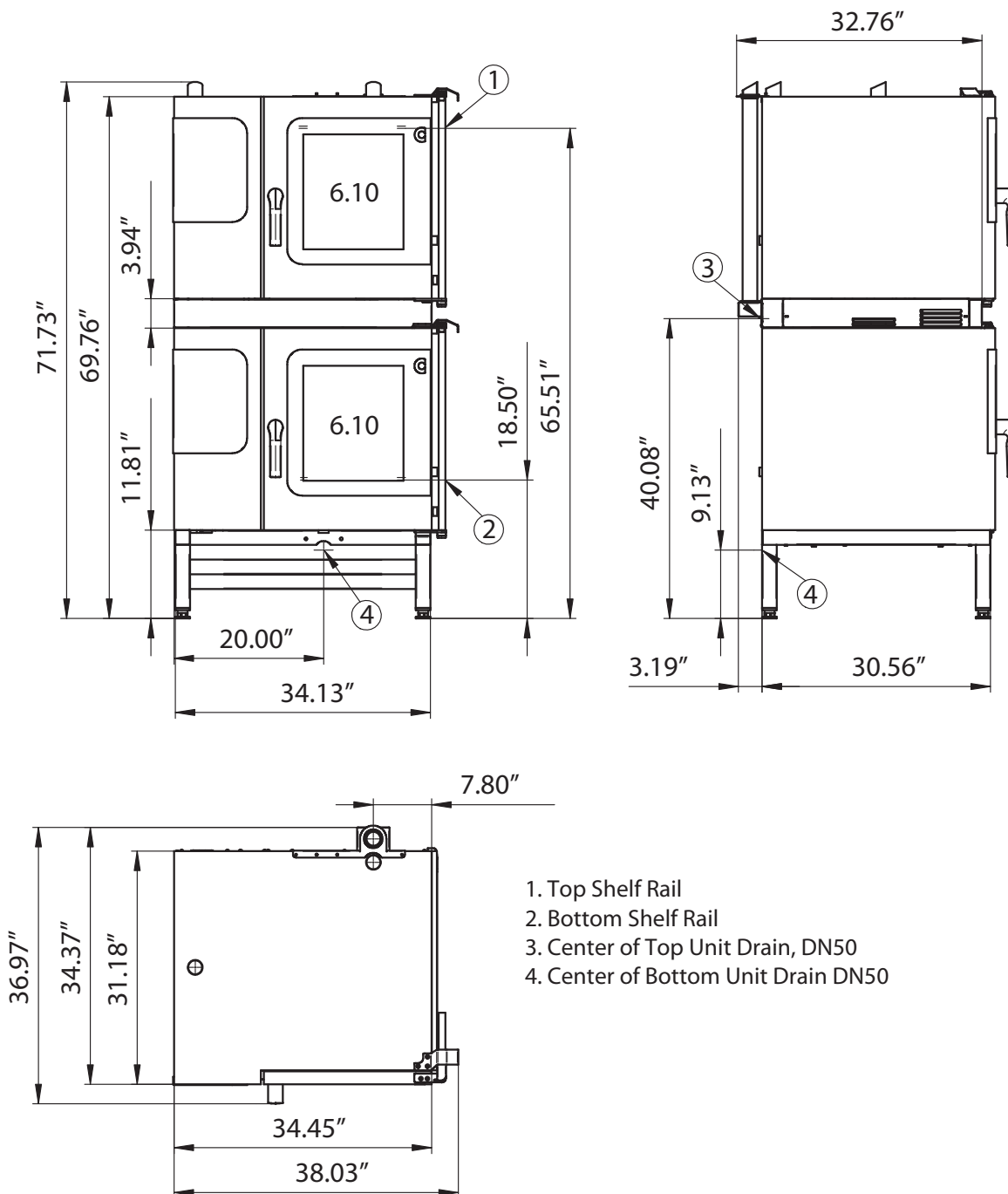

Stacking Kits - Convotherm 4



Dimensions

Weights

Views

Stacking Kits - Convotherm 4

Stacking Kit for stacking electric Convotherm 4 models:

6.20 on 6.20 & 6.20 on 10.20

Part # 3455864

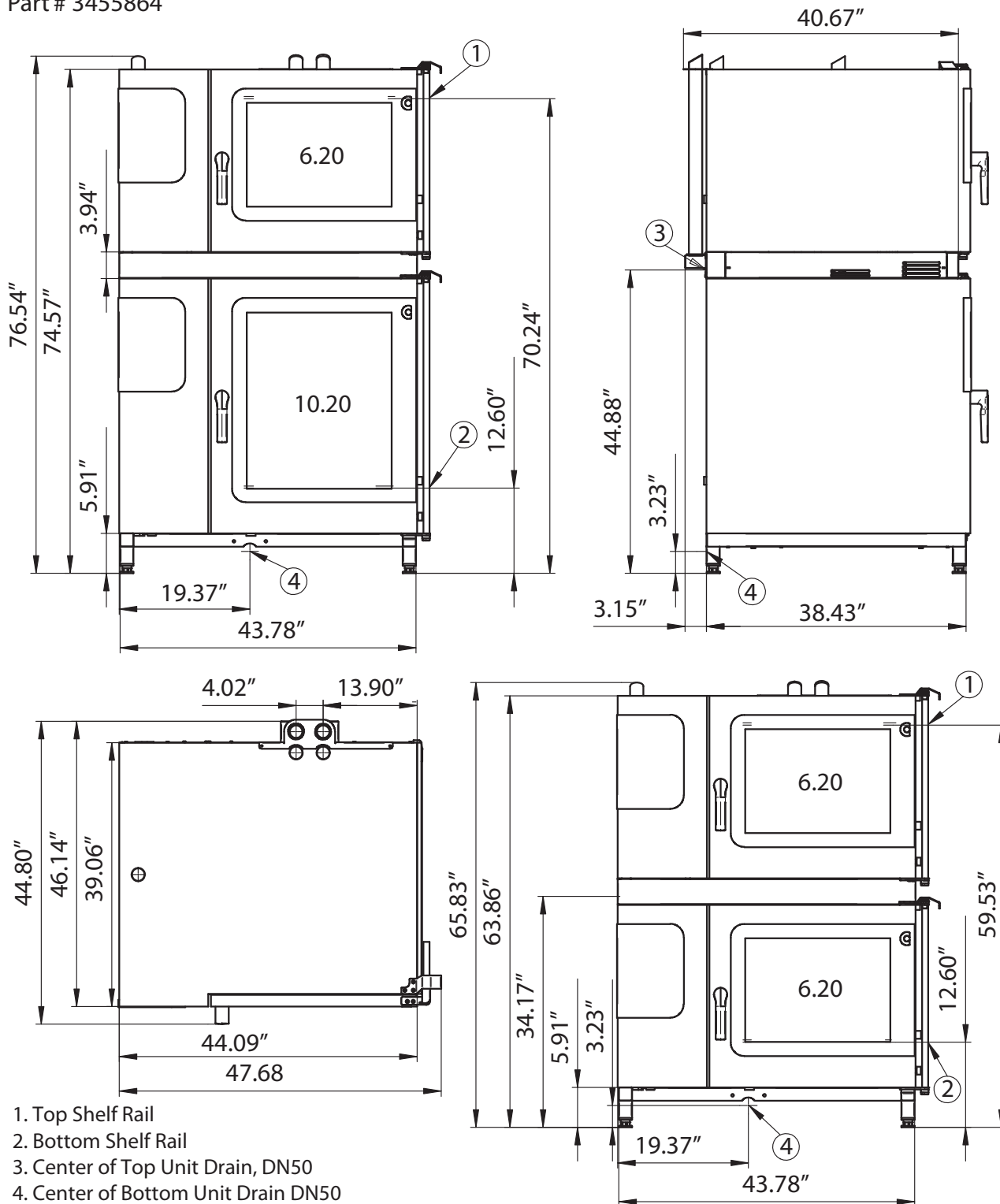

- 1. Top Shelf Rail
- 2. Bottom Shelf Rail
- 3. Center of Top Unit Drain, DN50
- 4. Center of Bottom Unit Drain DN50



Dimensions

Weights

Views

Stacking Kit for stacking two (2) 6.20 electric Convotherm 4 models on a 11" 13/16" high base:

Part # 3456267

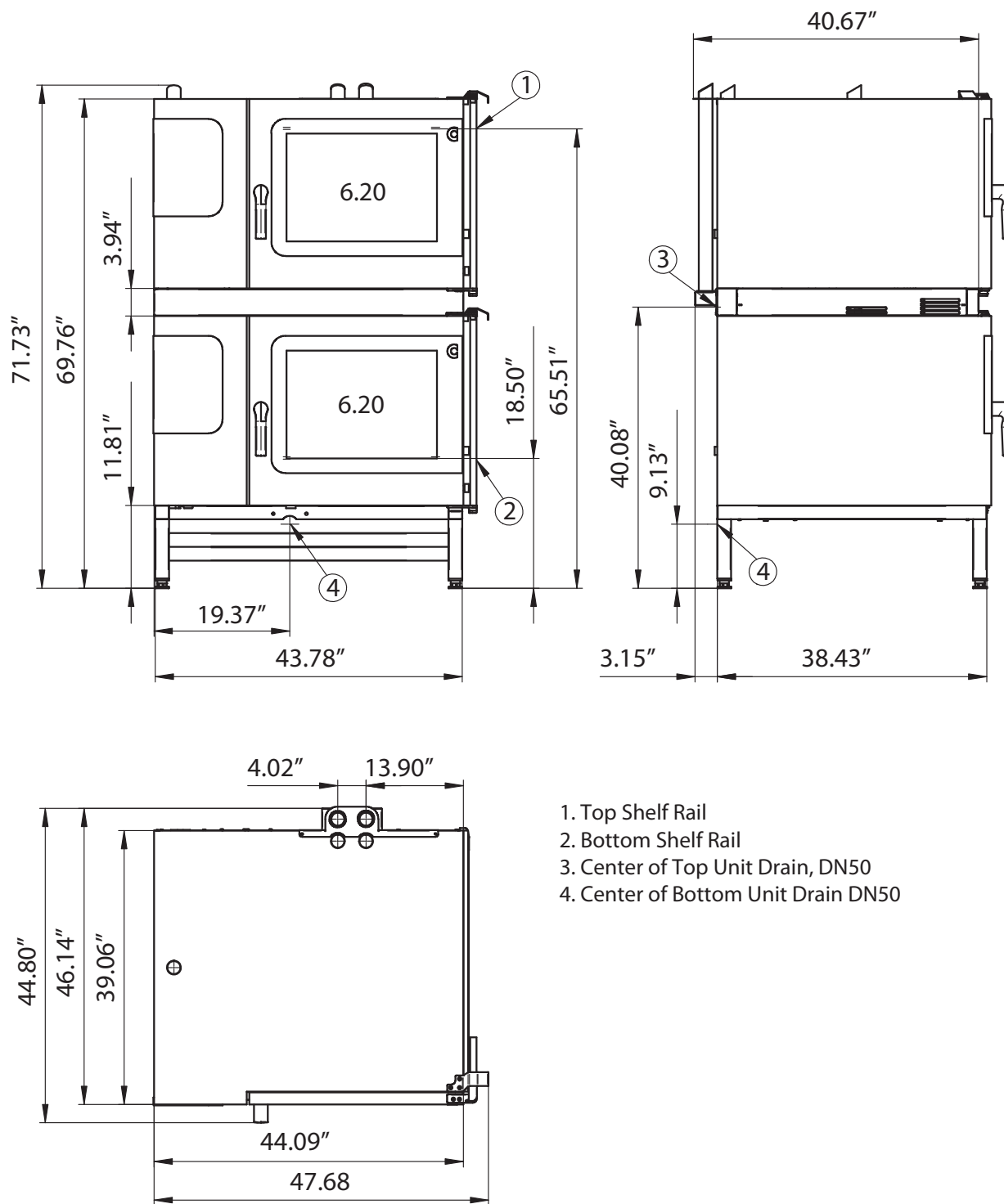

Stacking Kits - Convotherm 4



Dimensions

Weights

Views

Stacking Kits - Convotherm 4

Stacking Kit for stacking gas Convotherm 4 models:
6.10 on 6.10 & 6.10 on 10.10

Part # 3456171

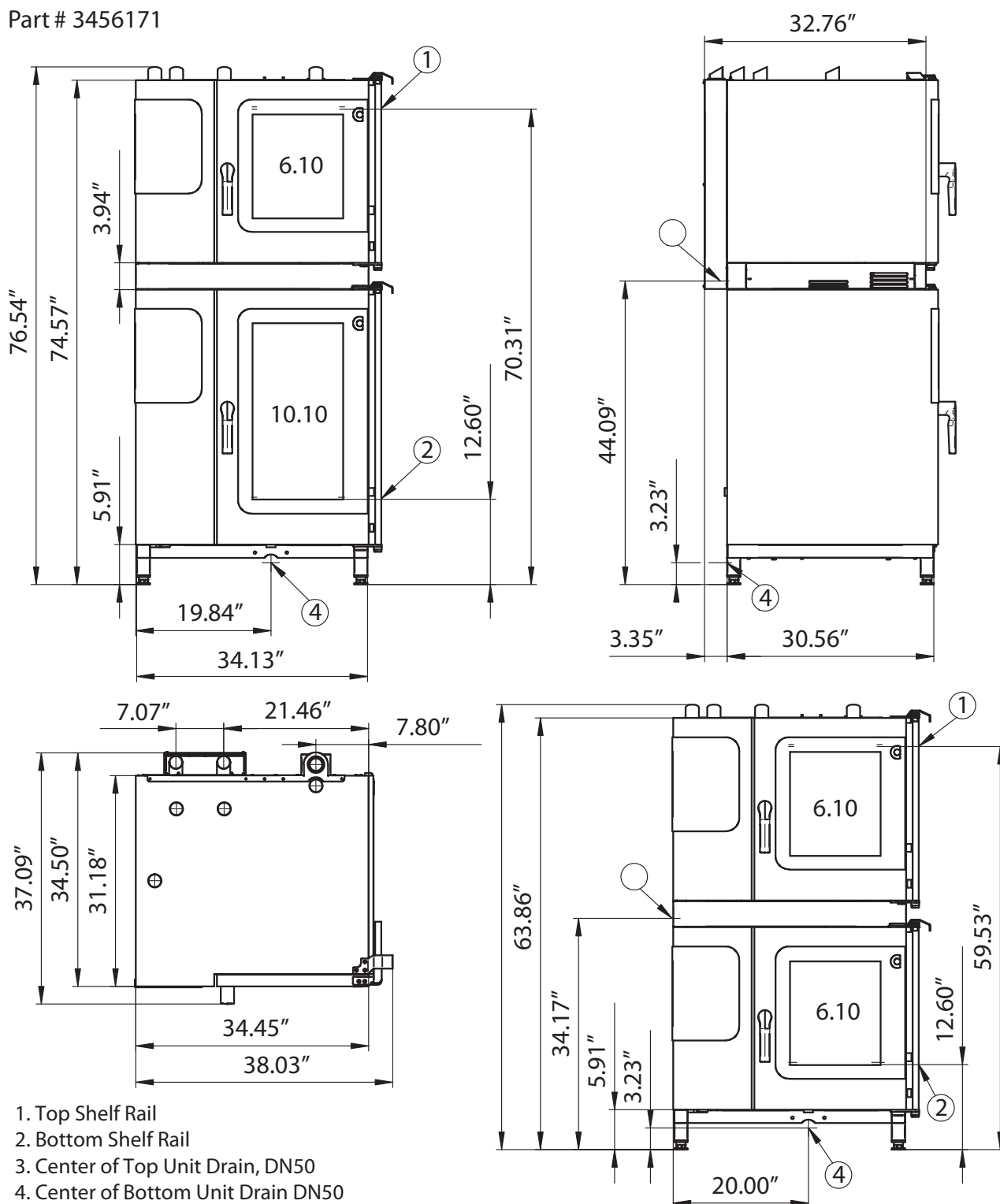

- 1. Top Shelf Rail
- 2. Bottom Shelf Rail
- 3. Center of Top Unit Drain, DN50
- 4. Center of Bottom Unit Drain DN50



Dimensions

Weights

Views

Stacking Kit for stacking two (2) 6.10 gas Convotherm 4 models on a 11" 13/16" high base:

Part # 3456276

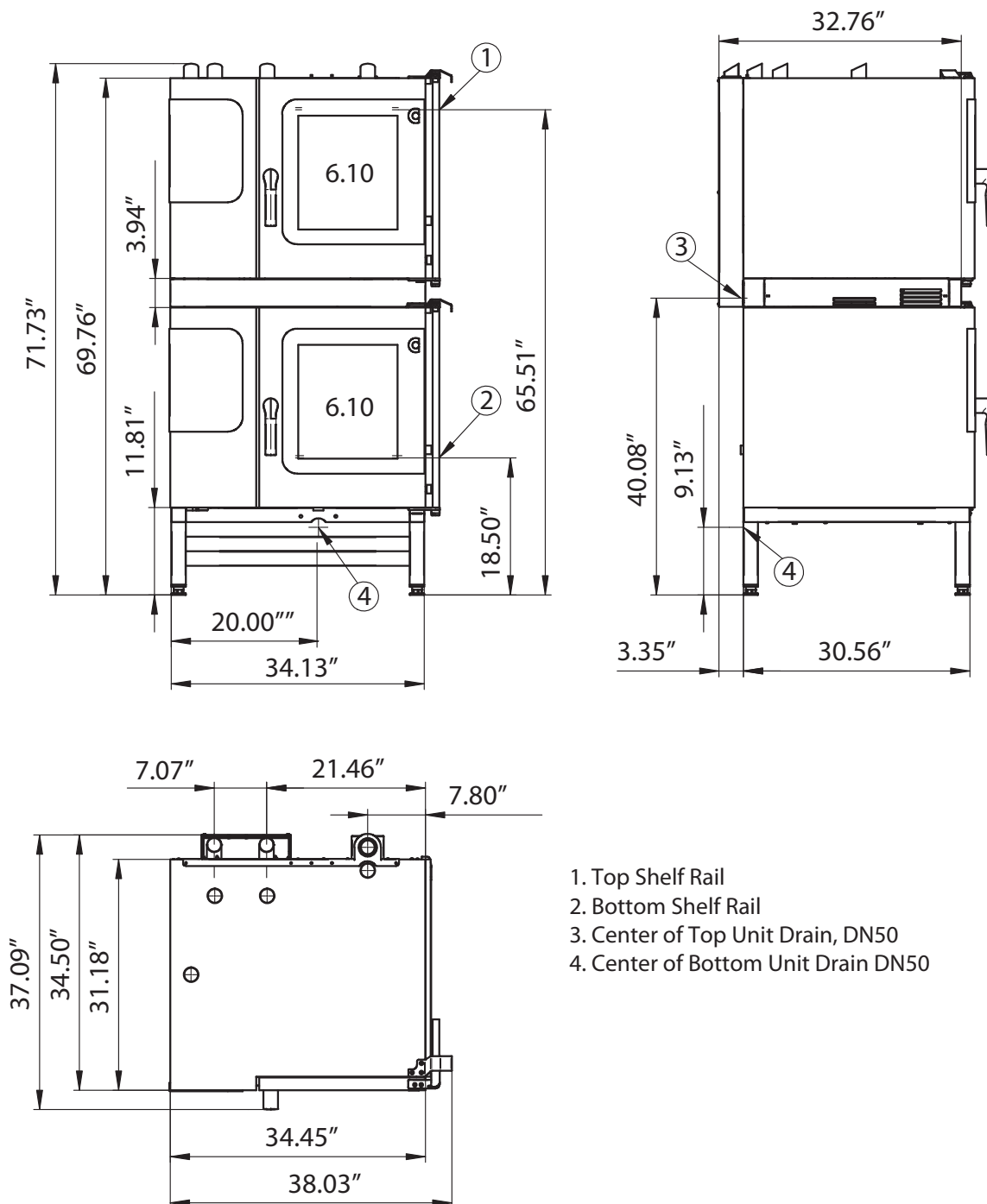

- 1. Top Shelf Rail
- 2. Bottom Shelf Rail
- 3. Center of Top Unit Drain, DN50
- 4. Center of Bottom Unit Drain DN50

Stacking Kits - Convotherm 4



Dimensions

Weights

Views

Stacking Kits - Convotherm 4

Stacking Kit for stacking gas Convotherm 4 models:
6.20 on 6.20 & 6.20 on 10.20

Part # 3456174

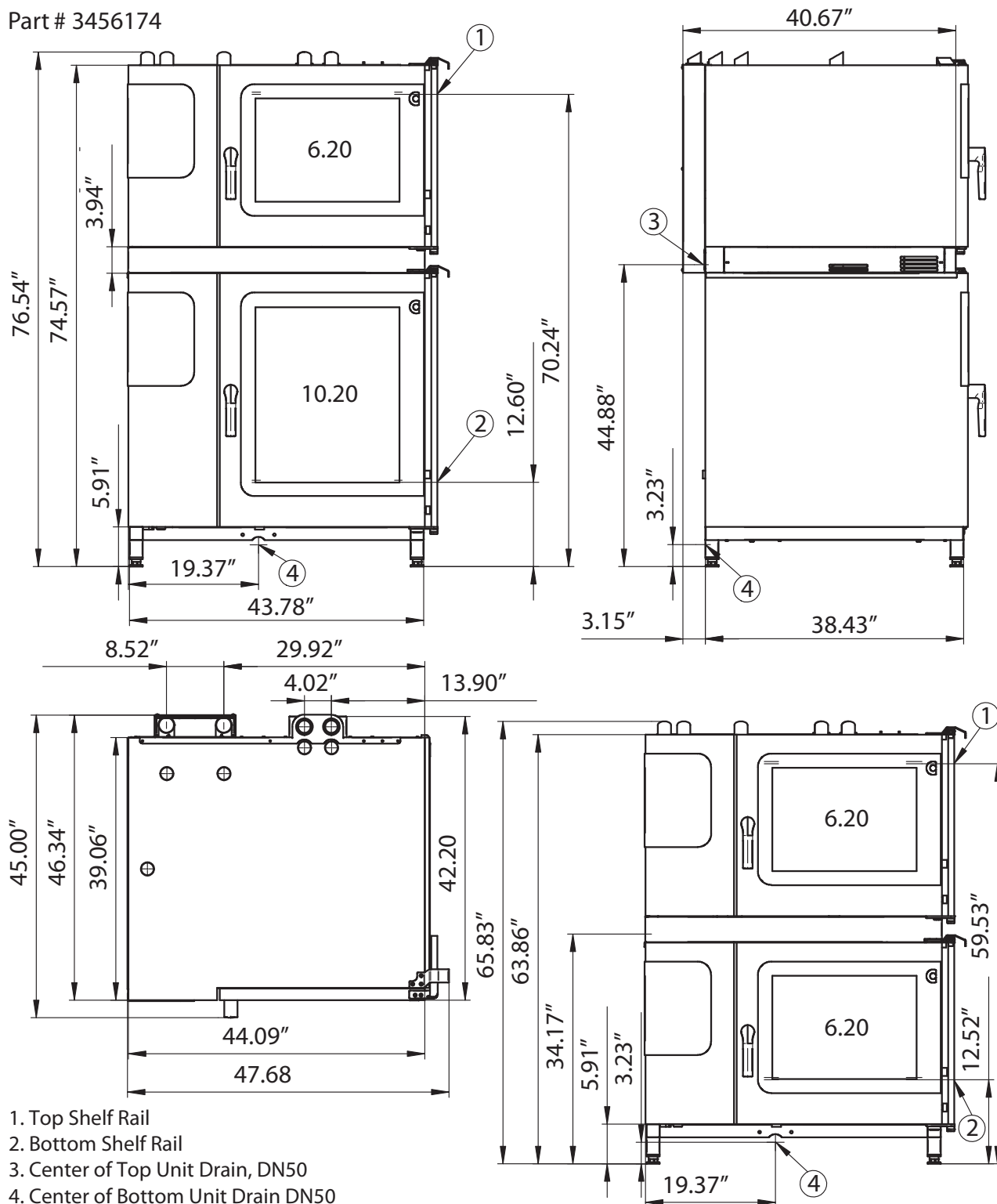



Dimensions

Weights

Views

Stacking Kit for stacking two (2) 6.20 gas Convotherm 4 models on a 11" 13/16" high base:

Part # 3456277

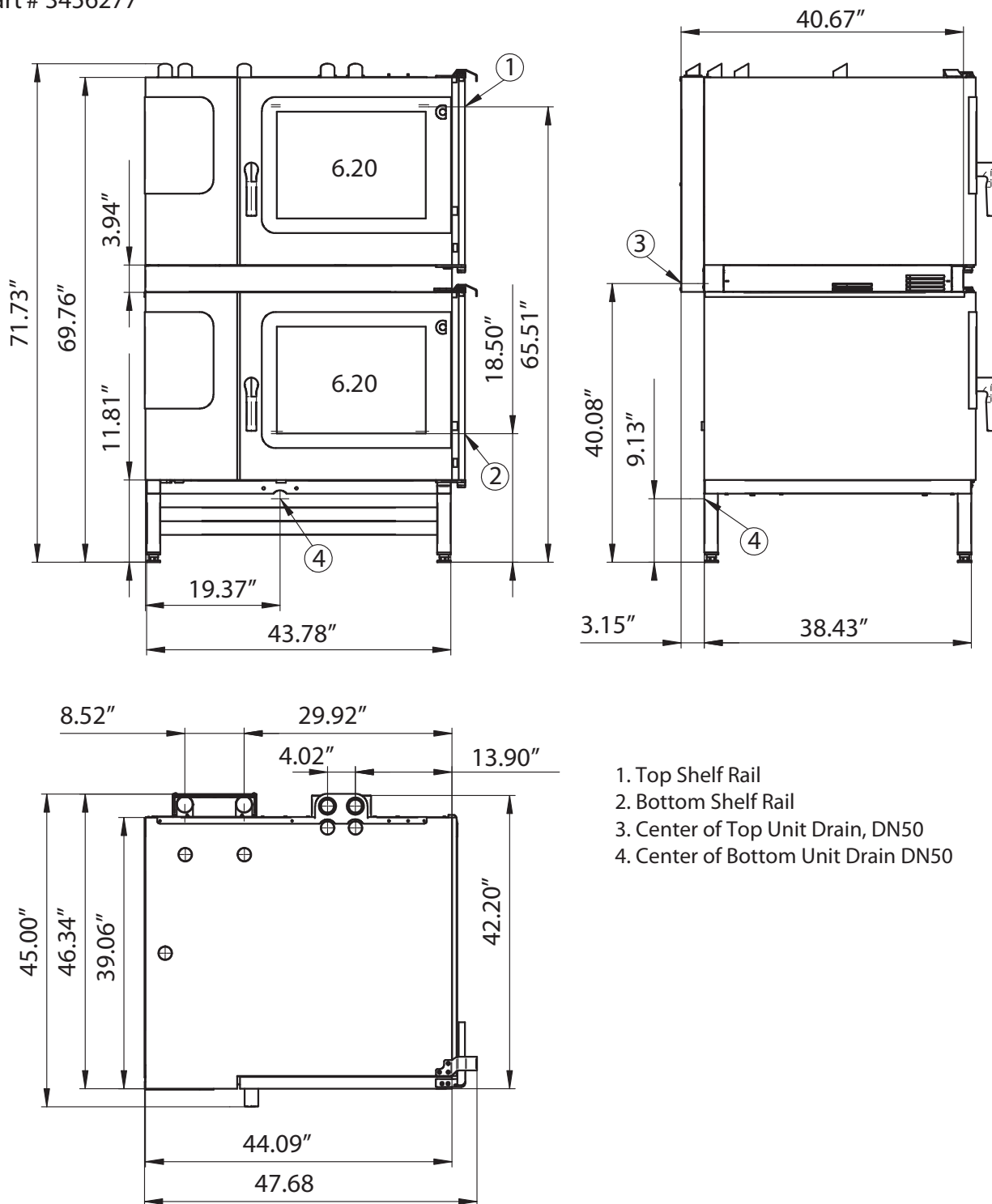

Stacking Kits - Convotherm 4



Department of Administration
 Purchasing Division
 2019 Washington Street East
 Post Office Box 50130
 Charleston, WV 25305-0130

State of West Virginia
 Centralized Request for Quote
 Equipment

Proc Folder: 1919880		Reason for Modification:	
Doc Description: Ovens for Mountaineer Challenge Academy Dining Facility		Addendum No. 1	
Proc Type: Central Purchase Order			
Date Issued	Solicitation Closes	Solicitation No	Version
2026-05-20	2026-05-27 13:30	CRFQ 0603 ADJ2600000021	2

BID RECEIVING LOCATION

BID CLERK
 DEPARTMENT OF ADMINISTRATION
 PURCHASING DIVISION
 2019 WASHINGTON ST E
 CHARLESTON WV 25305
 US

VENDOR

Vendor Customer Code: 203432
Vendor Name : Douglas Equipment
Address : 301
Street : North St
City : Bluefield
State : WV **Country :** US **Zip :** 24701
Principal Contact : Samantha Radford
Vendor Contact Phone: 304-327-2958 **Extension:**

FOR INFORMATION CONTACT THE BUYER

David H Pauline
 304-558-0067
 david.h.pauline@wv.gov

Vendor Signature X **FEIN#** 55-0585890 **DATE** 5/27/26

All offers subject to all terms and conditions contained in this solicitation

ADDITIONAL INFORMATION

Addendum No. 1

To provide responses to the vendor technical questions, see attached.

Bid opening date and time remains May 27, 2026, at 1:30 pm. EST.

No other changes.

INVOICE TO**SHIP TO**ADJUTANT GENERALS
OFFICE
1703 COONSKIN DRADJUTANT GENERALS
OFFICE
1001 ARMY RDCHARLESTON WV
USKINGWOOD WV
US

Line	Comm Ln Desc	Qty	Unit Issue	Unit Price	Total Price
1	Gas Combi Ovens	2.00000	EA	\$18,172.62	\$36,345.24

Comm Code**Manufacturer****Specification****Model #**

48101507

Convothrem

See attached quote for spec

C4 ET 6.20GS-N

Extended Description:

Please refer to the Exhibit "A" Pricing Page to input unit pricing.

SCHEDULE OF EVENTS

<u>Line</u>	<u>Event</u>	<u>Event Date</u>
1	Vendor Technical Questions Due By 11:00 am. EST.	2026-05-19

SOLICITATION NUMBER: CRFQ ADJ2600000021
Addendum Number: 1

The purpose of this addendum is to modify the solicitation identified as (“ADJ2600000021”) to reflect the change(s) identified and described below.

Applicable Addendum Category:

- Modify bid opening date and time.
- Modify specifications of product or service being sought.
- Attachment of vendor questions and responses.
- Attachment of pre-bid sign-in sheet.
- Correction of error.
- Other.

Description of Modification to Solicitation:

- 1) To provide responses to the Vendor Technical Questions, see attached
- 2) The bid opening date and time remains May 27, 2026, at 1:30 pm. EST.

No other changes.

Additional Documentation: Documentation related to this Addendum (if any) has been included herewith as Attachment A and is specifically incorporated herein by reference.

Terms and Conditions:

1. All provisions of the Solicitation and other addenda not modified herein shall remain in full force and effect.
2. Vendor should acknowledge receipt of all addenda issued for this Solicitation by completing an Addendum Acknowledgment, a copy of which is included herewith. Failure to acknowledge addenda may result in bid disqualification. The addendum acknowledgement should be submitted with the bid to expedite document processing.



DEPARTMENT OF THE ARMY
JOINT FORCES HEADQUARTERS WEST VIRGINIA
1707 COONSKIN DRIVE
CHARLESTON, WEST VIRGINIA 25311-1026

May 19, 2026

ADDENDUM NO. 1- CRFQ-ADJ2600000021

RE: Ovens for the Mountaineer Challenge Academy

TO: Prospective Bidders

FROM: West Virginia Adjutant General's Office

PART 1 – TO ISSUE RESPONSES TO TECHNICAL QUESTIONS RECEIVED

Q1: What size combi ovens are you all wanting? “There are a few options ranging from 6, 10, 20 pan options. I have attached a brochure for example.”

A1: The two (2) combi oven sizes should accommodate a 6-pan option.

Q2: What voltage and gas type is needed for the ovens?

A2: 120v voltage and natural gas type.

Q3: Please confirm the delivery/install location address and if there is a loading dock at the location?

A3: There is a loading dock located at Camp Dawson - Mountaineer Challenge Academy – Dining Facility Building # 443 - 1001 Army Road, Kingwood, WV 26537. Once the shipment arrives, the security at the front gate will call the facility and the driver will be escorted inside the complex to the building.

Q4: Will the installers need to remove any existing equipment? If so please provide make and model of items being removed from location?

A4: No, installers will not need to remove any existing equipment. The Vendor must deliver the combi ovens inside the building, uncrate the units in place within three (3) feet of existing equipment and utilities, provide all hoses and connectors to make all electrical and plumbing connections, and ensure the units are working correctly and are ready for immediate operation. Vendor is to demonstrate programming options to MCA Staff and provide minimal preventative maintenance, troubleshooting, repair, and diagnostic instructions.

Q5: There is not a specific manufacture or model number for this request. Are there specifications available for the unit to be purchased?

A5: Convotherm Maxx Pro Model No. C4 ET 6.20GS-N, or equal, and per the solicitation specifications in the General Requirements section listed under 3.1.1.

ADDENDUM ACKNOWLEDGEMENT FORM
SOLICITATION NO.: CRFQ ADJ260000021

Instructions: Please acknowledge receipt of all addenda issued with this solicitation by completing this addendum acknowledgment form. Check the box next to each addendum received and sign below. Failure to acknowledge addenda may result in bid disqualification.

Acknowledgment: I hereby acknowledge receipt of the following addenda and have made the necessary revisions to my proposal, plans and/or specification, etc.

Addendum Numbers Received:

(Check the box next to each addendum received)

- | | | | |
|-------------------------------------|----------------|--------------------------|-----------------|
| <input checked="" type="checkbox"/> | Addendum No. 1 | <input type="checkbox"/> | Addendum No. 6 |
| <input type="checkbox"/> | Addendum No. 2 | <input type="checkbox"/> | Addendum No. 7 |
| <input type="checkbox"/> | Addendum No. 3 | <input type="checkbox"/> | Addendum No. 8 |
| <input type="checkbox"/> | Addendum No. 4 | <input type="checkbox"/> | Addendum No. 9 |
| <input type="checkbox"/> | Addendum No. 5 | <input type="checkbox"/> | Addendum No. 10 |

I understand that failure to confirm the receipt of addenda may be cause for rejection of this bid. I further understand that that any verbal representation made or assumed to be made during any oral discussion held between Vendor's representatives and any state personnel is not binding. Only the information issued in writing and added to the specifications by an official addendum is binding.

Douglas Equipment

Company

Authorized Signature

5/27/2026

Date

NOTE: This addendum acknowledgment should be submitted with the bid to expedite document processing.

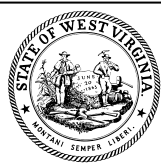

Department of Administration
 Purchasing Division
 2019 Washington Street East
 Post Office Box 50130
 Charleston, WV 25305-0130

**State of West Virginia
 Centralized Request for Quote
 Equipment**

Proc Folder: 1919880
Doc Description: Ovens for Mountaineer Challenge Academy Dining Facility
Proc Type: Central Purchase Order
Reason for Modification:

Date Issued	Solicitation Closes	Solicitation No	Version
2026-05-11	2026-05-27 13:30	CRFQ 0603 ADJ2600000021	1

BID RECEIVING LOCATION

BID CLERK
 DEPARTMENT OF ADMINISTRATION
 PURCHASING DIVISION
 2019 WASHINGTON ST E
 CHARLESTON WV 25305
 US

VENDOR

Vendor Customer Code: 203432
Vendor Name : Douglas Equipment
Address : 301
Street : North St
City : Bluefield
State : wv **Country :** US **Zip :** 24701
Principal Contact : 24701
Vendor Contact Phone: 304-327-2958 **Extension:**

FOR INFORMATION CONTACT THE BUYER

David H Pauline
 304-558-0067
 david.h.pauline@wv.gov

Vendor Signature X **FEIN#** 55-0585890 **DATE** 5/27/2026

All offers subject to all terms and conditions contained in this solicitation

ADDITIONAL INFORMATION

The West Virginia Purchasing Division is soliciting bids on behalf of the Adjutant General's Office, Mountaineer Challenge Academy North (MCAN), to establish a one-time purchase contract to provide (2) new combi ovens at Camp Dawson (MCAN Dining Facility) in Kingwood, WV, per the attached specifications, and documents.

INVOICE TO		SHIP TO	
ADJUTANT GENERALS OFFICE 1703 COONSKIN DR		ADJUTANT GENERALS OFFICE 1001 ARMY RD	
CHARLESTON	WV	KINGWOOD	WV
US		US	

Line	Comm Ln Desc	Qty	Unit Issue	Unit Price	Total Price
1	Gas Combi Ovens	2.00000	EA	\$18,172.62	\$36,345.24

Comm Code	Manufacturer	Specification	Model #
48101507	Convothem	See attached quote for spec	C4 ET 6.20GS-N

Extended Description:
Please refer to the Exhibit "A" Pricing Page to input unit pricing.

SCHEDULE OF EVENTS

<u>Line</u>	<u>Event</u>	<u>Event Date</u>
1	Vendor Technical Questions Due By 11:00 am. EST.	2026-05-19

INSTRUCTIONS TO VENDORS SUBMITTING BIDS

1. **REVIEW DOCUMENTS THOROUGHLY:** The attached documents contain a solicitation for bids. Please read these instructions and all documents attached in their entirety. These instructions provide critical information about requirements that if overlooked could lead to disqualification of a Vendor's bid. All bids must be submitted in accordance with the provisions contained in these instructions and the Solicitation. Failure to do so may result in disqualification of Vendor's bid.

2. **MANDATORY TERMS:** The Solicitation may contain **mandatory** provisions identified by the use of the words "**must**," "**will**," and "**shall**." Failure to comply with a mandatory term in the Solicitation will result in bid disqualification.

3. **PRE-BID MEETING:** The item identified below shall apply to this Solicitation.

A pre-bid meeting will not be held prior to bid opening

A **MANDATORY PRE-BID** meeting will be held at the following place and time:

All Vendors submitting a bid must attend the **mandatory** pre-bid meeting. Failure to attend the **mandatory** pre-bid meeting shall result in disqualification of the Vendor's bid. No one individual is permitted to represent more than one vendor at the pre-bid meeting. Any individual that does attempt to represent two or more vendors will be required to select one vendor to which the individual's attendance will be attributed. The vendors not selected will be deemed to have not attended the pre-bid meeting unless another individual attended on their behalf.

An attendance sheet provided at the pre-bid meeting shall serve as the official document verifying attendance. Any person attending the pre-bid meeting on behalf of a Vendor must list on the attendance sheet his or her name and the name of the Vendor he or she is representing. It is the Vendor's responsibility to locate the attendance sheet and provide the required information. Failure to complete the attendance sheet as required may result in disqualification of Vendor's bid.

Vendors who arrive after the starting time but prior to the end of the pre-bid will be permitted to sign in but are charged with knowing all matters discussed at the pre-bid.

Any discussions or answers to questions at the pre-bid meeting are preliminary in nature and are non-binding. Official and binding answers to questions will be published in a written addendum to the Solicitation prior to bid opening.

4. VENDOR QUESTION DEADLINE: Vendors may submit questions relating to this Solicitation to the Purchasing Division. Questions must be submitted in writing. All questions **must be submitted on or before the date listed below and to the address listed below to be considered.** A written response will be published in a Solicitation addendum if a response is possible and appropriate. Non-written discussions, conversations, or questions and answers regarding this Solicitation are preliminary in nature and are non-binding.

Submitted emails should have the solicitation number in the subject line. Question

Submission Deadline:

Submit Questions to:
2019 Washington Street, East Charleston, WV 25305
Fax: (304) 558-3970
Email:

5. VERBAL COMMUNICATION: Any verbal communication between the Vendor and any State personnel is not binding, including verbal communication at the mandatory pre-bid conference. Only information issued in writing and added to the Solicitation by an official written addendum by the Purchasing Division is binding.

6. BID SUBMISSION: All bids must be submitted on or before the date and time of the bid opening listed in section 7 below. Vendors can submit bids electronically through wvOASIS, in paper form delivered to the Purchasing Division at the address listed below either in person or by courier, or in facsimile form by faxing to the Purchasing Division at the number listed below. Notwithstanding the foregoing, the Purchasing Division may prohibit the submission of bids electronically through wvOASIS at its sole discretion. Such a prohibition will be contained and communicated in the wvOASIS system resulting in the Vendor's inability to submit bids through wvOASIS. The Purchasing Division will not accept bids or modification of bids via email.

Bids submitted in paper, facsimile, or via wvOASIS must contain a signature. Failure to submit a bid in any form without a signature will result in rejection of your bid.

A bid submitted in paper or facsimile form should contain the information listed below on the face of the submission envelope or fax cover sheet. Otherwise, the bid may be rejected by the Purchasing Division.

VENDOR NAME:

BUYER:

SOLICITATION NO.:

BID OPENING DATE:

BID OPENING TIME:

FAX NUMBER:

Any bid received by the Purchasing Division staff is considered to be in the possession of the Purchasing Division and will not be returned for any reason.

Bid Delivery Address and Fax Number:

Department of Administration, Purchasing Division 2019 Washington Street East

Charleston, WV 25305-0130

Fax: 304-558-3970

7. BID OPENING: Bids submitted in response to this Solicitation will be opened at the location identified below on the date and time listed below. Delivery of a bid after the bid opening date and time will result in bid disqualification. For purposes of this Solicitation, a bid is considered delivered when confirmation of delivery is provided by wvOASIS (in the case of electronic submission) or when the bid is time stamped by the official Purchasing Division time clock (in the case of hand delivery or via delivery by mail).

Bid Opening Date and Time:

Bid Opening Location:

Department of Administration, Purchasing Division

2019 Washington Street East

Charleston, WV 25305-0130

8. ADDENDUM ACKNOWLEDGEMENT: Changes or revisions to this Solicitation will be made by an official written addendum issued by the Purchasing Division. Vendor should acknowledge receipt of all addenda issued with this Solicitation by completing an Addendum Acknowledgement Form. Failure to acknowledge addenda may result in bid disqualification. The addendum acknowledgement should be submitted with the bid to expedite document processing.

9. **BID FORMATTING:** Vendor should type or electronically enter the information onto its bid to prevent errors in the evaluation. Failure to type or electronically enter the information may result in bid disqualification.

10. **ALTERNATE MODEL OR BRAND:** Unless the box below is checked, any model, brand, or specification listed in this Solicitation establishes the acceptable level of quality only and is not intended to reflect a preference for, or in any way favor, a particular brand or vendor. Vendors may bid alternates to a listed model or brand provided that the alternate is at least equal to the model or brand and complies with the required specifications. The equality of any alternate being bid shall be determined by the State at its sole discretion. Any Vendor bidding an alternate model or brand **shall** clearly identify the alternate items in its bid and should include manufacturer's specifications, industry literature, and/or any other relevant documentation demonstrating the equality of the alternate items. Failure to provide information for alternate items **may** be grounds for rejection of a Vendor's bid.

[] This Solicitation is based upon a standardized commodity established under W. Va. Code § 5A-3-61. Vendors are expected to bid the standardized commodity identified. Failure to bid the standardized commodity will result in your firm's bid being rejected.

11. **COMMUNICATION LIMITATIONS:** In accordance with West Virginia Code of State Rules §148-1-6.6.2, communication with the State of West Virginia or any of its employees regarding this Solicitation during the solicitation, bid, evaluation or award periods, except through the Purchasing Division, is strictly prohibited without prior Purchasing Division approval. Purchasing Division approval for such communication is implied for all agency delegated and exempt purchases.

12. **REGISTRATION:** Prior to Contract award, the apparent successful Vendor **must** be properly registered with the West Virginia Purchasing Division and must have paid the \$125 fee, if applicable.

13. **UNIT PRICE:** Unit prices **shall** prevail in cases of a discrepancy in the Vendor's bid.

14. **PREFERENCE:** Vendor Preference may be requested in purchases of motor vehicles or construction and maintenance equipment and machinery used in highway and other infrastructure projects. Any request for preference must be submitted in writing with the bid, must specifically identify the preference requested with reference to the applicable subsection of West Virginia Code § 5A-3-37, and must include with the bid any information necessary to evaluate and confirm the applicability of the requested preference. A request form to help facilitate the request can be found at: www.state.wv.us/admin/purchase/vrc/Venpref.pdf.

15A. RECIPROCAL PREFERENCE: The State of West Virginia applies a reciprocal preference to all solicitations for commodities and printing in accordance with W. Va. Code § 5A-3-37(b). In effect, non-resident vendors receiving a preference in their home states, will see that same preference granted to West Virginia resident vendors bidding against them in West Virginia. Any request for reciprocal preference must include with the bid any information necessary to evaluate and confirm the applicability of the preference. A request form to help facilitate the request can be found at: www.state.wv.us/admin/purchase/vrc/Venpref.pdf.

15. SMALL, WOMEN-OWNED, OR MINORITY-OWNED BUSINESSES:

For any solicitations publicly advertised for bid, in accordance with West Virginia Code §5A-3-37 and W. Va. CSR § 148-22-9, any non-resident vendor certified as a small, women-owned, or minority-owned business under W. Va. CSR § 148-22-9 shall be provided the same preference made available to any resident vendor. Any non-resident small, women-owned, or minority-owned business must identify itself as such in writing, must submit that writing to the Purchasing Division with its bid, and must be properly certified under W. Va. CSR § 148-22-9 prior to contract award to receive the preferences made available to resident vendors.

16. WAIVER OF MINOR IRREGULARITIES: The Director reserves the right to waive minor irregularities in bids or specifications in accordance with West Virginia Code of State Rules § 148-1-4.7.

17. ELECTRONIC FILE ACCESS RESTRICTIONS: Vendor must ensure that its submission in wvOASIS can be accessed and viewed by the Purchasing Division staff immediately upon bid opening. The Purchasing Division will consider any file that cannot be immediately accessed and viewed at the time of the bid opening (such as, encrypted files, password protected files, or incompatible files) to be blank or incomplete as context requires and are therefore unacceptable. A vendor will not be permitted to unencrypt files, remove password protections, or resubmit documents after bid opening to make a file viewable if those documents are required with the bid. A Vendor may be required to provide document passwords or remove access restrictions to allow the Purchasing Division to print or electronically save documents provided that those documents are viewable by the Purchasing Division prior to obtaining the password or removing the access restriction.

18. NON-RESPONSIBLE: The Purchasing Division Director reserves the right to reject the bid of any vendor as Non-Responsible in accordance with W. Va. Code of State Rules § 148-1-5.3, when the Director determines that the vendor submitting the bid does not have the capability to fully perform or lacks the integrity and reliability to assure good-faith performance.”

19. ACCEPTANCE/REJECTION: The State may accept or reject any bid in whole, or in part in accordance with W. Va. Code of State Rules § 148-1-4.6. and § 148-1-6.3.”

20. **WITH THE BID REQUIREMENTS:** In instances where these specifications require documentation or other information with the bid, and a vendor fails to provide it with the bid, the Director of the Purchasing Division reserves the right to request those items after bid opening and prior to contract award pursuant to the authority to waive minor irregularities in bids or specifications under W. Va. CSR § 148-1-4.7. This authority does not apply to instances where state law mandates receipt with the bid.

21. **EMAIL NOTIFICATION OF AWARD:** The Purchasing Division will attempt to provide bidders with e-mail notification of contract award when a solicitation that the bidder participated in has been awarded. For notification purposes, bidders must provide the Purchasing Division with a valid email address in the bid response. Bidders may also monitor wvOASIS or the Purchasing Division's website to determine when a contract has been awarded.

22. **EXCEPTIONS AND CLARIFICATIONS:** The Solicitation contains the specifications that **shall** form the basis of a contractual agreement. **Vendor shall clearly mark any exceptions, clarifications, or other proposed modifications in its bid.** Exceptions to, clarifications of, or modifications of a requirement or term and condition of the Solicitation may result in bid disqualification.

GENERAL TERMS AND CONDITIONS:

1. CONTRACTUAL AGREEMENT: Issuance of an Award Document signed by the Purchasing Division Director, or his designee, and approved as to form by the Attorney General's office constitutes acceptance by the State of this Contract made by and between the State of West Virginia and the Vendor. Vendor's signature on its bid, or on the Contract if the Contract is not the result of a bid solicitation, signifies Vendor's agreement to be bound by and accept the terms and conditions contained in this Contract.

2. DEFINITIONS: As used in this Solicitation/Contract, the following terms shall have the meanings attributed to them below. Additional definitions may be found in the specifications included with this Solicitation/Contract.

2.1. "Agency" or "Agencies" means the agency, board, commission, or other entity of the State of West Virginia that is identified on the first page of the Solicitation or any other public entity seeking to procure goods or services under this Contract.

2.2. "Bid" or "Proposal" means the vendors submitted response to this solicitation.

2.3. "Contract" means the binding agreement that is entered into between the State and the Vendor to provide the goods or services requested in the Solicitation.

2.4. "Director" means the Director of the West Virginia Department of Administration, Purchasing Division.

2.5. "Purchasing Division" means the West Virginia Department of Administration, Purchasing Division.

2.6. "Award Document" means the document signed by the Agency and the Purchasing Division, and approved as to form by the Attorney General, that identifies the Vendor as the contract holder.

2.7. "Solicitation" means the official notice of an opportunity to supply the State with goods or services that is published by the Purchasing Division.

2.8. "State" means the State of West Virginia and/or any of its agencies, commissions, boards, etc. as context requires.

2.9. "Vendor" or "Vendors" means any entity submitting a bid in response to the Solicitation, the entity that has been selected as the lowest responsible bidder, or the entity that has been awarded the Contract as context requires.

3. CONTRACT TERM; RENEWAL; EXTENSION: The term of this Contract shall be determined in accordance with the category that has been identified as applicable to this Contract below:

Term Contract

Initial Contract Term: The Initial Contract Term will be for a period of _____. The Initial Contract Term becomes effective on the effective start date listed on the first page of this Contract, identified as the State of West Virginia contract cover page containing the signatures of the Purchasing Division, Attorney General, and Encumbrance clerk (or another page identified as _____), and the Initial Contract Term ends on the effective end date also shown on the first page of this Contract.

Renewal Term: This Contract may be renewed upon the mutual written consent of the Agency, and the Vendor, with approval of the Purchasing Division and the Attorney General's office (Attorney General approval is as to form only). Any request for renewal should be delivered to the Agency and then submitted to the Purchasing Division thirty (30) days prior to the expiration date of the initial contract term or appropriate renewal term. A Contract renewal shall be in accordance with the terms and conditions of the original contract. Unless otherwise specified below, renewal of this Contract is limited to _____ successive one (1) year periods or multiple renewal periods of less than one year, provided that the multiple renewal periods do not exceed the total number of months available in all renewal years combined. Automatic renewal of this Contract is prohibited. Renewals must be approved by the Vendor, Agency, Purchasing Division and Attorney General's office (Attorney General approval is as to form only)

Alternate Renewal Term – This contract may be renewed for _____ successive _____ year periods or shorter periods provided that they do not exceed the total number of months contained in all available renewals. Automatic renewal of this Contract is prohibited. Renewals must be approved by the Vendor, Agency, Purchasing Division and Attorney General's office (Attorney General approval is as to form only)

Delivery Order Limitations: In the event that this contract permits delivery orders, a delivery order may only be issued during the time this Contract is in effect. Any delivery order issued within one year of the expiration of this Contract shall be effective for one year from the date the delivery order is issued. No delivery order may be extended beyond one year after this Contract has expired.

Fixed Period Contract: This Contract becomes effective upon Vendor's receipt of the notice to proceed and must be completed within _____ days.

Fixed Period Contract with Renewals: This Contract becomes effective upon Vendor's receipt of the notice to proceed and part of the Contract more fully described in the attached specifications must be completed within _____ days. Upon completion of the work covered by the preceding sentence, the vendor agrees that:

the contract will continue for _____ years;

the contract may be renewed for _____ successive _____ year periods or shorter periods provided that they do not exceed the total number of months contained in all available renewals. Automatic renewal of this Contract is prohibited. Renewals must be approved by the Vendor, Agency, Purchasing Division and Attorney General's Office (Attorney General approval is as to form only).

One-Time Purchase: The term of this Contract shall run from the issuance of the Award Document until all of the goods contracted for have been delivered, but in no event will this Contract extend for more than one fiscal year.

Construction/Project Oversight: This Contract becomes effective on the effective start date listed on the first page of this Contract, identified as the State of West Virginia contract cover page containing the signatures of the Purchasing Division, Attorney General, and Encumbrance clerk (or another page identified as _____), and continues until the project for which the vendor is providing oversight is complete.

Other: Contract Term specified in _____

4. AUTHORITY TO PROCEED: Vendor is authorized to begin performance of this contract on the date of encumbrance listed on the front page of the Award Document unless either the box for "Fixed Period Contract" or "Fixed Period Contract with Renewals" has been checked in Section 3 above. If either "Fixed Period Contract" or "Fixed Period Contract with Renewals" has been checked, Vendor must not begin work until it receives a separate notice to proceed from the State. The notice to proceed will then be incorporated into the Contract via change order to memorialize the official date that work commenced.

5. QUANTITIES: The quantities required under this Contract shall be determined in accordance with the category that has been identified as applicable to this Contract below.

Open End Contract: Quantities listed in this Solicitation/Award Document are approximations only, based on estimates supplied by the Agency. It is understood and agreed that the Contract shall cover the quantities actually ordered for delivery during the term of the Contract, whether more or less than the quantities shown.

Service: The scope of the service to be provided will be more clearly defined in the specifications included herewith.

Combined Service and Goods: The scope of the service and deliverable goods to be provided will be more clearly defined in the specifications included herewith.

One-Time Purchase: This Contract is for the purchase of a set quantity of goods that are identified in the specifications included herewith. Once those items have been delivered, no additional goods may be procured under this Contract without an appropriate change order approved by the Vendor, Agency, Purchasing Division, and Attorney General's office.

Construction: This Contract is for construction activity more fully defined in the specifications.

6. EMERGENCY PURCHASES: The Purchasing Division Director may authorize the Agency to purchase goods or services in the open market that Vendor would otherwise provide under this Contract if those goods or services are for immediate or expedited delivery in an emergency. Emergencies shall include, but are not limited to, delays in transportation or an unanticipated increase in the volume of work. An emergency purchase in the open market, approved by the Purchasing Division Director, shall not constitute a breach of this Contract and shall not entitle the Vendor to any form of compensation or damages. This provision does not excuse the State from fulfilling its obligations under a One-Time Purchase contract.

7. REQUIRED DOCUMENTS: All of the items checked in this section must be provided to the Purchasing Division by the Vendor as specified:

LICENSE(S) / CERTIFICATIONS / PERMITS: In addition to anything required under the Section of the General Terms and Conditions entitled Licensing, the apparent successful Vendor shall furnish proof of the following licenses, certifications, and/or permits upon request and in a form acceptable to the State. The request may be prior to or after contract award at the State's sole discretion.

The apparent successful Vendor shall also furnish proof of any additional licenses or certifications contained in the specifications regardless of whether or not that requirement is listed above.

8. INSURANCE: The apparent successful Vendor shall furnish proof of the insurance identified by a checkmark below prior to Contract award. The insurance coverages identified below must be maintained throughout the life of this contract. Thirty (30) days prior to the expiration of the insurance policies, Vendor shall provide the Agency with proof that the insurance mandated herein has been continued. Vendor must also provide Agency with immediate notice of any changes in its insurance policies, including but not limited to, policy cancelation, policy reduction, or change in insurers. The apparent successful Vendor shall also furnish proof of any additional insurance requirements contained in the specifications prior to Contract award regardless of whether that insurance requirement is listed in this section.

Vendor must maintain:

Commercial General Liability Insurance in at least an amount of: _____ per occurrence.

Automobile Liability Insurance in at least an amount of: _____ per occurrence.

Professional/Malpractice/Errors and Omission Insurance in at least an amount of: _____ per occurrence. Notwithstanding the forgoing, Vendor's are not required to list the State as an additional insured for this type of policy.

Commercial Crime and Third Party Fidelity Insurance in an amount of: _____ per occurrence.

Cyber Liability Insurance in an amount of: _____ per occurrence.

Builders Risk Insurance in an amount equal to 100% of the amount of the Contract.

Pollution Insurance in an amount of: _____ per occurrence.

Aircraft Liability in an amount of: _____ per occurrence.

9. WORKERS' COMPENSATION INSURANCE: Vendor shall comply with laws relating to workers compensation, shall maintain workers' compensation insurance when required, and shall furnish proof of workers' compensation insurance upon request.

10. VENUE: All legal actions for damages brought by Vendor against the State shall be brought in the West Virginia Claims Commission. Other causes of action must be brought in the West Virginia court authorized by statute to exercise jurisdiction over it.

11. LIQUIDATED DAMAGES: This clause shall in no way be considered exclusive and shall not limit the State or Agency's right to pursue any other available remedy. Vendor shall pay liquidated damages in the amount specified below or as described in the specifications:

_____ for _____.

Liquidated Damages Contained in the Specifications.

Liquidated Damages Are Not Included in this Contract.

12. ACCEPTANCE: Vendor's signature on its bid, or on the certification and signature page, constitutes an offer to the State that cannot be unilaterally withdrawn, signifies that the product or service proposed by vendor meets the mandatory requirements contained in the Solicitation for that product or service, unless otherwise indicated, and signifies acceptance of the terms and conditions contained in the Solicitation unless otherwise indicated.

13. PRICING: The pricing set forth herein is firm for the life of the Contract, unless specified elsewhere within this Solicitation/Contract by the State. A Vendor's inclusion of price adjustment provisions in its bid, without an express authorization from the State in the Solicitation to do so, may result in bid disqualification. Notwithstanding the foregoing, Vendor must extend any publicly advertised sale price to the State and invoice at the lower of the contract price or the publicly advertised sale price.

14. PAYMENT IN ARREARS: Payments for goods/services will be made in arrears only upon receipt of a proper invoice, detailing the goods/services provided or receipt of the goods/services, whichever is later. Notwithstanding the foregoing, payments for software maintenance, licenses, or subscriptions may be paid annually in advance.

15. PAYMENT METHODS: Vendor must accept payment by electronic funds transfer and P-Card. (The State of West Virginia's Purchasing Card program, administered under contract by a banking institution, processes payment for goods and services through state designated credit cards.)

16. TAXES: The Vendor shall pay any applicable sales, use, personal property or any other taxes arising out of this Contract and the transactions contemplated thereby. The State of West Virginia is exempt from federal and state taxes and will not pay or reimburse such taxes.

17. ADDITIONAL FEES: Vendor is not permitted to charge additional fees or assess additional charges that were not either expressly provided for in the solicitation published by the State of West Virginia, included in the Contract, or included in the unit price or lump sum bid amount that Vendor is required by the solicitation to provide. Including such fees or charges as notes to the solicitation may result in rejection of vendor's bid. Requesting such fees or charges be paid after the contract has been awarded may result in cancellation of the contract.

18. FUNDING: This Contract shall continue for the term stated herein, contingent upon funds being appropriated by the Legislature or otherwise being made available. In the event funds are not appropriated or otherwise made available, this Contract becomes void and of no effect beginning on July 1 of the fiscal year for which funding has not been appropriated or otherwise made available. If that occurs, the State may notify the Vendor that an alternative source of funding has been obtained and thereby avoid the automatic termination. Non-appropriation or non-funding shall not be considered an event of default.

19. CANCELLATION: The Purchasing Division Director reserves the right to cancel this Contract immediately upon written notice to the vendor if the materials or workmanship supplied do not conform to the specifications contained in the Contract. The Purchasing Division Director may also cancel any purchase or Contract upon 30 days written notice to the Vendor in accordance with West Virginia Code of State Rules § 148-1-5.2.

20. TIME: Time is of the essence regarding all matters of time and performance in this Contract.

21. APPLICABLE LAW: This Contract is governed by and interpreted under West Virginia law without giving effect to its choice of law principles. Any information provided in specification manuals, or any other source, verbal or written, which contradicts or violates the West Virginia Constitution, West Virginia Code, or West Virginia Code of State Rules is void and of no effect.

22. COMPLIANCE WITH LAWS: Vendor shall comply with all applicable federal, state, and local laws, regulations and ordinances. By submitting a bid, Vendor acknowledges that it has reviewed, understands, and will comply with all applicable laws, regulations, and ordinances.

SUBCONTRACTOR COMPLIANCE: Vendor shall notify all subcontractors providing commodities or services related to this Contract that as subcontractors, they too are required to comply with all applicable laws, regulations, and ordinances. Notification under this provision must occur prior to the performance of any work under the contract by the subcontractor.

23. ARBITRATION: Any references made to arbitration contained in this Contract, Vendor's bid, or in any American Institute of Architects documents pertaining to this Contract are hereby deleted, void, and of no effect.

24. MODIFICATIONS: This writing is the parties' final expression of intent. Notwithstanding anything contained in this Contract to the contrary no modification of this Contract shall be binding without mutual written consent of the Agency, and the Vendor, with approval of the Purchasing Division and the Attorney General's office (Attorney General approval is as to form only). Any change to existing contracts that adds work or changes contract cost, and were not included in the original contract, must be approved by the Purchasing Division and the Attorney General's Office (as to form) prior to the implementation of the change or commencement of work affected by the change.

25. WAIVER: The failure of either party to insist upon a strict performance of any of the terms or provision of this Contract, or to exercise any option, right, or remedy herein contained, shall not be construed as a waiver or a relinquishment for the future of such term, provision, option, right, or remedy, but the same shall continue in full force and effect. Any waiver must be expressly stated in writing and signed by the waiving party.

26. SUBSEQUENT FORMS: The terms and conditions contained in this Contract shall supersede any and all subsequent terms and conditions which may appear on any form documents submitted by Vendor to the Agency or Purchasing Division such as price lists, order forms, invoices, sales agreements, or maintenance agreements, and includes internet websites or other electronic documents. Acceptance or use of Vendor's forms does not constitute acceptance of the terms and conditions contained thereon.

27. ASSIGNMENT: Neither this Contract nor any monies due, or to become due hereunder, may be assigned by the Vendor without the express written consent of the Agency, the Purchasing Division, the Attorney General's office (as to form only), and any other government agency or office that may be required to approve such assignments.

28. WARRANTY: The Vendor expressly warrants that the goods and/or services covered by this Contract will: (a) conform to the specifications, drawings, samples, or other description furnished or specified by the Agency; (b) be merchantable and fit for the purpose intended; and (c) be free from defect in material and workmanship.

29. STATE EMPLOYEES: State employees are not permitted to utilize this Contract for personal use and the Vendor is prohibited from permitting or facilitating the same.

30. PRIVACY, SECURITY, AND CONFIDENTIALITY: The Vendor agrees that it will not disclose to anyone, directly or indirectly, any such personally identifiable information or other confidential information gained from the Agency, unless the individual who is the subject of the information consents to the disclosure in writing or the disclosure is made pursuant to the Agency's policies, procedures, and rules. Vendor further agrees to comply with the Confidentiality Policies and Information Security Accountability Requirements, set forth in www.state.wv.us/admin/purchase/privacy.

31. YOUR SUBMISSION IS A PUBLIC DOCUMENT: Vendor's entire response to the Solicitation and the resulting Contract are public documents. As public documents, they will be disclosed to the public following the bid/proposal opening or award of the contract, as required by the competitive bidding laws of West Virginia Code §§ 5A-3-1 et seq., 5-22-1 et seq., and 5G-1-1 et seq. and the Freedom of Information Act West Virginia Code §§ 29B-1-1 et seq.

DO NOT SUBMIT MATERIAL YOU CONSIDER TO BE CONFIDENTIAL, A TRADE SECRET, OR OTHERWISE NOT SUBJECT TO PUBLIC DISCLOSURE.

Submission of any bid, proposal, or other document to the Purchasing Division constitutes your explicit consent to the subsequent public disclosure of the bid, proposal, or document. The Purchasing Division will disclose any document labeled "confidential," "proprietary," "trade secret," "private," or labeled with any other claim against public disclosure of the documents, to include any "trade secrets" as defined by West Virginia Code § 47-22-1 et seq. All submissions are subject to public disclosure without notice.

32. LICENSING: In accordance with West Virginia Code of State Rules § 148-1-6.1.e, Vendor must be licensed and in good standing in accordance with any and all state and local laws and requirements by any state or local agency of West Virginia, including, but not limited to, the West Virginia Secretary of State's Office, the West Virginia Tax Department, West Virginia Insurance Commission, or any other state agency or political subdivision. Obligations related to political subdivisions may include, but are not limited to, business licensing, business and occupation taxes, inspection compliance, permitting, etc. Upon request, the Vendor must provide all necessary releases to obtain information to enable the Purchasing Division Director or the Agency to verify that the Vendor is licensed and in good standing with the above entities.

SUBCONTRACTOR COMPLIANCE: Vendor shall notify all subcontractors providing commodities or services related to this Contract that as subcontractors, they too are required to be licensed, in good standing, and up-to-date on all state and local obligations as described in this section. Obligations related to political subdivisions may include, but are not limited to, business licensing, business and occupation taxes, inspection compliance, permitting, etc. Notification under this provision must occur prior to the performance of any work under the contract by the subcontractor.

33. ANTITRUST: In submitting a bid to, signing a contract with, or accepting a Award Document from any agency of the State of West Virginia, the Vendor agrees to convey, sell, assign, or transfer to the State of West Virginia all rights, title, and interest in and to all causes of action it may now or hereafter acquire under the antitrust laws of the United States and the State of West Virginia for price fixing and/or unreasonable restraints of trade relating to the particular commodities or services purchased or acquired by the State of West Virginia. Such assignment shall be made and become effective at the time the purchasing agency tenders the initial payment to Vendor.

34. VENDOR NON-CONFLICT: Neither Vendor nor its representatives are permitted to have any interest, nor shall they acquire any interest, direct or indirect, which would compromise the performance of its services hereunder. Any such interests shall be promptly presented in detail to the Agency.

35. VENDOR RELATIONSHIP: The relationship of the Vendor to the State shall be that of an independent contractor and no principal-agent relationship or employer-employee relationship is contemplated or created by this Contract. The Vendor as an independent contractor is solely liable for the acts and omissions of its employees and agents. Vendor shall be responsible for selecting, supervising, and compensating any and all individuals employed pursuant to the terms of this Solicitation and resulting contract. Neither the Vendor, nor any employees or subcontractors of the Vendor, shall be deemed to be employees of the State for any purpose whatsoever. Vendor shall be exclusively responsible for payment of employees and contractors for all wages and salaries, taxes, withholding payments, penalties, fees, fringe benefits, professional liability insurance premiums, contributions to insurance and pension, or other deferred compensation plans, including but not limited to, Workers' Compensation and Social Security obligations, licensing fees, etc. and the filing of all necessary documents, forms, and returns pertinent to all of the foregoing.

Vendor shall hold harmless the State, and shall provide the State and Agency with a defense against any and all claims including, but not limited to, the foregoing payments, withholdings, contributions, taxes, Social Security taxes, and employer income tax returns.

36. INDEMNIFICATION: The Vendor agrees to indemnify, defend, and hold harmless the State and the Agency, their officers, and employees from and against: (1) Any claims or losses for services rendered by any subcontractor, person, or firm performing or supplying services, materials, or supplies in connection with the performance of the Contract; (2) Any claims or losses resulting to any person or entity injured or damaged by the Vendor, its officers, employees, or subcontractors by the publication, translation, reproduction, delivery, performance, use, or disposition of any data used under the Contract in a manner not authorized by the Contract, or by Federal or State statutes or regulations; and (3) Any failure of the Vendor, its officers, employees, or subcontractors to observe State and Federal laws including, but not limited to, labor and wage and hour laws.

37. NO DEBT CERTIFICATION: In accordance with West Virginia Code §§ 5A-3-10a and 5-22-1(i), the State is prohibited from awarding a contract to any bidder that owes a debt to the State or a political subdivision of the State. By submitting a bid, or entering into a contract with the State, Vendor is affirming that (1) for construction contracts, the Vendor is not in default on any monetary obligation owed to the state or a political subdivision of the state, and (2) for all other contracts, neither the Vendor nor any related party owe a debt as defined above, and neither the Vendor nor any related party are in employer default as defined in the statute cited above unless the debt or employer default is permitted under the statute.

38. CONFLICT OF INTEREST: Vendor, its officers or members or employees, shall not presently have or acquire an interest, direct or indirect, which would conflict with or compromise the performance of its obligations hereunder. Vendor shall periodically inquire of its officers, members and employees to ensure that a conflict of interest does not arise. Any conflict of interest discovered shall be promptly presented in detail to the Agency.

39. REPORTS: Vendor shall provide the Agency and/or the Purchasing Division with the following reports identified by a checked box below:

Such reports as the Agency and/or the Purchasing Division may request. Requested reports may include, but are not limited to, quantities purchased, agencies utilizing the contract, total contract expenditures by agency, etc.

Quarterly reports detailing the total quantity of purchases in units and dollars, along with a listing of purchases by agency. Quarterly reports should be delivered to the Purchasing Division via email at purchasing.division@wv.gov.

40. BACKGROUND CHECK: In accordance with W. Va. Code § 15-2D-3, the State reserves the right to prohibit a service provider's employees from accessing sensitive or critical information or to be present at the Capitol complex based upon results addressed from a criminal background check. Service providers should contact the West Virginia Division of Protective Services by phone at (304) 558-9911 for more information.

41. PREFERENCE FOR USE OF DOMESTIC STEEL PRODUCTS: Except when authorized by the Director of the Purchasing Division pursuant to W. Va. Code § 5A-3-56, no contractor may use or supply steel products for a State Contract Project other than those steel products made in the United States. A contractor who uses steel products in violation of this section may be subject to civil penalties pursuant to W. Va. Code § 5A-3-56. As used in this section:

- a. "State Contract Project" means any erection or construction of, or any addition to, alteration of or other improvement to any building or structure, including, but not limited to, roads or highways, or the installation of any heating or cooling or ventilating plants or other equipment, or the supply of and materials for such projects, pursuant to a contract with the State of West Virginia for which bids were solicited on or after June 6, 2001.
- b. "Steel Products" means products rolled, formed, shaped, drawn, extruded, forged, cast, fabricated or otherwise similarly processed, or processed by a combination of two or more or such operations, from steel made by the open hearth, basic oxygen, electric furnace, Bessemer or other steel making process.
- c. The Purchasing Division Director may, in writing, authorize the use of foreign steel products if:
 1. The cost for each contract item used does not exceed one tenth of one percent (.1%) of the total contract cost or two thousand five hundred dollars (\$2,500.00), whichever is greater. For the purposes of this section, the cost is the value of the steel product as delivered to the project; or
 2. The Director of the Purchasing Division determines that specified steel materials are not produced in the United States in sufficient quantity or otherwise are not reasonably available to meet contract requirements.

42. PREFERENCE FOR USE OF DOMESTIC ALUMINUM, GLASS, AND STEEL: In Accordance with W. Va. Code § 5-19-1 et seq., and W. Va. CSR § 148-10-1 et seq., for every contract or subcontract, subject to the limitations contained herein, for the construction, reconstruction, alteration, repair, improvement or maintenance of public works or for the purchase of any item of machinery or equipment to be used at sites of public works, only domestic aluminum, glass or steel products shall be supplied unless the spending officer determines, in writing, after the receipt of offers or bids, (1) that the cost of domestic aluminum, glass or steel products is unreasonable or inconsistent with the public interest of the State of West Virginia, (2) that domestic aluminum, glass or steel products are not produced in sufficient quantities to meet the contract requirements, or (3) the available domestic aluminum, glass, or steel do not meet the contract specifications. This provision only applies to public works contracts awarded in an amount more than fifty thousand dollars (\$50,000) or public works contracts that require more than ten thousand pounds of steel products.

The cost of domestic aluminum, glass, or steel products may be unreasonable if the cost is more than twenty percent (20%) of the bid or offered price for foreign made aluminum, glass, or steel products. If the domestic aluminum, glass or steel products to be supplied or produced in a “substantial labor surplus area”, as defined by the United States Department of Labor, the cost of domestic aluminum, glass, or steel products may be unreasonable if the cost is more than thirty percent (30%) of the bid or offered price for foreign made aluminum, glass, or steel products. This preference shall be applied to an item of machinery or equipment, as indicated above, when the item is a single unit of equipment or machinery manufactured primarily of aluminum, glass or steel, is part of a public works contract and has the sole purpose or of being a permanent part of a single public works project. This provision does not apply to equipment or machinery purchased by a spending unit for use by that spending unit and not as part of a single public works project.

All bids and offers including domestic aluminum, glass or steel products that exceed bid or offer prices including foreign aluminum, glass or steel products after application of the preferences provided in this provision may be reduced to a price equal to or lower than the lowest bid or offer price for foreign aluminum, glass or steel products plus the applicable preference. If the reduced bid or offer prices are made in writing and supersede the prior bid or offer prices, all bids or offers, including the reduced bid or offer prices, will be reevaluated in accordance with this rule.

43. INTERESTED PARTY SUPPLEMENTAL DISCLOSURE: W. Va. Code § 6D-1-2 requires that for contracts with an actual or estimated value of at least \$1 million, the Vendor must submit to the Agency a disclosure of interested parties prior to beginning work under this Contract. Additionally, the Vendor must submit a supplemental disclosure of interested parties reflecting any new or differing interested parties to the contract, which were not included in the original pre-work interested party disclosure, within 30 days following the completion or termination of the contract. A copy of that form is included with this solicitation or can be obtained from the WV Ethics Commission. This requirement does not apply to publicly traded companies listed on a national or international stock exchange. A more detailed definition of interested parties can be obtained from the form referenced above.

44. PROHIBITION AGAINST USED OR REFURBISHED: Unless expressly permitted in the solicitation published by the State, Vendor must provide new, unused commodities, and is prohibited from supplying used or refurbished commodities, in fulfilling its responsibilities under this Contract.

45. VOID CONTRACT CLAUSES: This Contract is subject to the provisions of West Virginia Code § 5A-3-62, which automatically voids certain contract clauses that violate State law.

46. ISRAEL BOYCOTT: Bidder understands and agrees that, pursuant to W. Va. Code § 5A-3-63, it is prohibited from engaging in a boycott of Israel during the term of this contract.

DESIGNATED CONTACT: Vendor appoints the individual identified in this Section as the Contract Administrator and the initial point of contact for matters relating to this Contract.

(Printed Name and Title) Samantha Radford

(Address) 301 North St Bluefiled WV 24701

(Phone Number) / (Fax Number) 304-327-2958

(email address) sradford@dougleasequipment.us

CERTIFICATION AND SIGNATURE: By signing below, or submitting documentation through *wvOASIS*, I certify that: I have reviewed this Solicitation/Contract in its entirety; that I understand the requirements, terms and conditions, and other information contained herein; that this bid, offer or proposal constitutes an offer to the State that cannot be unilaterally withdrawn; that the product or service proposed meets the mandatory requirements contained in the Solicitation/Contract for that product or service, unless otherwise stated herein; that the Vendor accepts the terms and conditions contained in the Solicitation, unless otherwise stated herein; that I am submitting this bid, offer or proposal for review and consideration; that this bid or offer was made without prior understanding, agreement, or connection with any entity submitting a bid or offer for the same material, supplies, equipment or services; that this bid or offer is in all respects fair and without collusion or fraud; that this Contract is accepted or entered into without any prior understanding, agreement, or connection to any other entity that could be considered a violation of law; that I am authorized by the Vendor to execute and submit this bid, offer, or proposal, or any documents related thereto on Vendor's behalf; that I am authorized to bind the vendor in a contractual relationship; and that to the best of my knowledge, the vendor has properly registered with any State agency that may require registration.

By signing below, I further certify that I understand this Contract is subject to the provisions of West Virginia Code § 5A-3-62, which automatically voids certain contract clauses that violate State law; and that pursuant to W. Va. Code 5A-3-63, the entity entering into this contract is prohibited from engaging in a boycott against Israel.

Douglas Equipment

(Company)

(Signature of Authorized Representative)

(Printed Name and Title of Authorized Representative) (Date)
Samantha Radford Project Manager 5/27/2026

(Phone Number) (Fax Number)
304-327-2958 sradford@dougleasequipment.us

(Email Address)

REQUEST FOR QUOTATION – CRFQ ADJ26*21
Gas Combi Ovens for MCA Dining Facility

SPECIFICATIONS

1. **PURPOSE AND SCOPE:** The West Virginia Purchasing Division is soliciting bids on behalf of the West Virginia Adjutant General’s Office to establish a contract for the one-time purchase of two (2) gas combi ovens for the Mountaineer Challenge Academy North (“MCAN”) Dining Facility (“DFAC”) at 1001 Army Road in Kingwood, West Virginia.

2. **DEFINITIONS:** The terms listed below shall have the meanings assigned to them below. Additional definitions can be found in section 2 of the General Terms and Conditions.
 - 2.1 **“Contract Item”** means stackable gas combi ovens as more fully described by these specifications.

 - 2.2 **“Pricing Page”** means the pages, contained in wvOASIS or attached as Exhibit A, upon which Vendor should list its proposed price for the Contract Items.

 - 2.3 **“Solicitation”** means the official notice of an opportunity to supply the State with goods or services that is published by the Purchasing Division.

3. **GENERAL REQUIREMENTS:**
 - 3.1 **Mandatory Contract Item Requirements:** Contract Item must meet or exceed the mandatory requirements listed below.
 - 3.1.1 **Contract Item #1 – Gas Combi Ovens - Quantity of Two (2)**
 - 3.1.1.1 Must be stainless-steel gas combi ovens with wire shelving.
 - 3.1.1.2 Ovens shall have a minimum of four (4) cooking modes, including hot air, steam, combi-steam, and retherm.
 - 3.1.1.3 Ovens must have the capability to be stackable and include all compatible hardware.
 - 3.1.1.4 Must include an anti-microbial door handle.
 - 3.1.1.5 Must include a Wi-Fi-enabled control panel.
 - 3.1.1.6 Must have a multi-point core temperature probe.
 - 3.1.1.7 Ovens shall have a five (5)-speed auto reversing fan.
 - 3.1.1.8 Must include all hoses and connectors.
 - 3.1.1.9 Must have a pull-out spray hose with an incoming water connection.
 - 3.1.1.10 Ovens must have a fully automatic, hands-free cleaning system.
 - 3.1.1.11 Must include compatible water filter treatment cartridges.

REQUEST FOR QUOTATION – CRFQ ADJ26*21
Gas Combi Ovens for MCA Dining Facility

- 3.1.1.12 Must include a maintenance start-up kit with compatible cleaning solutions.
- 3.1.1.13 Must have a minimum capacity for 18" x 26" full size sheet pans, or 12" x 20" x 1" hotel pans.
- 3.1.1.14 Manufacturer's standard warranty shall include two (2)-year parts and labor warranty.
- 3.1.1.15 **Vendor must deliver the combi ovens inside the building, uncrate the units in place within three (3) feet of existing equipment and utilities, provide all hoses and connectors to make all electrical and plumbing connections, and ensure the units are working correctly and are ready for immediate operation. Vendor is to demonstrate programming options to MCA Staff and provide minimal preventative maintenance, troubleshooting, repair, and diagnostic instructions.**

4. CONTRACT AWARD:

4.1 Contract Award: The Contract is intended to provide Agencies with a purchase price for the Contract Items. The Contract shall be awarded to the Vendor that provides the Contract Items meeting the required specifications for the lowest overall total cost as shown on the Pricing Pages.

4.2 Pricing Page: Vendor should complete the Pricing Page by indicating the unit price for each Contract Item on the Exhibit A and extending the Total for each to provide a Grand Total that is all inclusive of delivery and fees. Vendor should complete the Pricing Page in full as failure to complete the Pricing Page in its entirety may result in Vendor's bid being disqualified.

Vendor should type or electronically enter the information into the Pricing Page to prevent errors in the evaluation.

5. PAYMENT:

5.1 Payment: Vendor shall accept payment in accordance with the payment procedures of the State of West Virginia. Please send invoices to:

**WV Adjutant General's Office
ATTN: State Finance Office
1703 Coonskin Drive
Charleston, WV 25311**

REQUEST FOR QUOTATION – CRFQ ADJ26*21
Gas Combi Ovens for MCA Dining Facility

6. DELIVERY AND RETURN:

- 6.1 Shipment and Delivery:** Vendor shall ship the Contract Items immediately after being awarded this Contract and receiving a purchase order or notice to proceed. Vendor shall deliver the Contract Items within twenty-five (25) working days after receiving a purchase order or notice to proceed. Contract Items must be delivered to Agency at:

**MOUNTAINEER CHALLENGE PROGRAM NORTH
ATTN: DENA NUSE
1001 Army Road
Kingwood, WV 26537**

- 6.2 Late Delivery:** The Agency placing the order under this Contract must be notified in writing if the shipment of the Contract Items will be delayed for any reason. Any delay in delivery that could cause harm to an Agency will be grounds for cancellation of the Contract, and/or obtaining the Contract Items from a third party.

Any Agency seeking to obtain the Contract Items from a third party under this provision must first obtain approval of the Purchasing Division.

- 6.3 Delivery Payment/Risk of Loss:** Vendor shall deliver the Contract Items F.O.B. destination to the Agency's location.
- 6.4 Return of Unacceptable Items:** If the Agency deems the Contract Items to be unacceptable, the Contract Items shall be returned to Vendor at Vendor's expense and with no restocking charge. Vendor shall either make arrangements for the return within five (5) days of being notified that items are unacceptable, or permit the Agency to arrange for the return and reimburse Agency for delivery expenses. If the original packaging cannot be utilized for the return, Vendor will supply the Agency with appropriate return packaging upon request. All returns of unacceptable items shall be F.O.B. the Agency's location. The returned product shall either be replaced, or the Agency shall receive a full credit or refund for the purchase price, at the Agency's discretion.
- 6.5 Return Due to Agency Error:** Items ordered in error by the Agency will be returned for credit within 30 days of receipt, F.O.B. Vendor's location. Vendor shall not charge a restocking fee if returned products are in a resalable condition. Items shall be deemed to be in a resalable condition if they are unused and in the original packaging. Any restocking fee for items not in a resalable condition shall be the lower of the Vendor's customary restocking fee or 5% of the total invoiced value of the returned items.

REQUEST FOR QUOTATION – CRFQ ADJ26*21
Gas Combi Ovens for MCA Dining Facility

7 VENDOR DEFAULT:

7.1 The following shall be considered a vendor default under this Contract.

7.1.1 Failure to provide Contract Items in accordance with the requirements contained herein.

7.1.2 Failure to comply with other specifications and requirements contained herein.

7.1.3 Failure to comply with any laws, rules, and ordinances applicable to the Contract Services provided under this Contract.

7.1.4 Failure to remedy deficient performance upon request.

7.2 The following remedies shall be available to Agency upon default.

7.2.1 Immediate cancellation of the Contract.

7.2.2 Immediate cancellation of one or more release orders issued under this Contract.

7.2.3 Any other remedies available in law or equity.

Exhibit A: Pricing Page - CRFQ ADJ26*21
Combi Ovens for Mountaineer Challenge Academy Dining Facility

Item	Description	Brand/Make/Model	Quantity	Unit Price	Extended Price
3.1.1	Gas Combi Ovens	Convotherm C4 ET 6.20GS-N	2	\$ 18,172.62	\$ \$36,345.24
Failure to use this Pricing Page may result in disqualification				Total Bid Amount:	\$ \$36,345.24

Vendor Information:
Name: Douglas Equipment
Address: 301 North St Bluefield WV 24701
Phone: 304-327-2958
Email: srdford@douglasequipment.us
Authorized Signature:



Department of Administration
 Purchasing Division
 2019 Washington Street East
 Post Office Box 50130
 Charleston, WV 25305-0130

State of West Virginia
 Centralized Request for Quote
 Equipment

Proc Folder: 1919880			Reason for Modification:
Doc Description: Ovens for Mountaineer Challenge Academy Dining Facility			
Proc Type: Central Purchase Order			
Date Issued	Solicitation Closes	Solicitation No	Version
2026-05-11	2026-05-27 13:30	CRFQ 0603 ADJ2600000021	1

BID RECEIVING LOCATION

BID CLERK
 DEPARTMENT OF ADMINISTRATION
 PURCHASING DIVISION
 2019 WASHINGTON ST E
 CHARLESTON WV 25305
 US

VENDOR

Vendor Customer Code: 203432
Vendor Name : Douglas Equipment
Address : 301
Street : North St
City : Bluefield
State : WV **Country :**US **Zip :** 24701
Principal Contact : Samantha Radford
Vendor Contact Phone: 304-327-2958 **Extension:**

FOR INFORMATION CONTACT THE BUYER

David H Pauline
 304-558-0067
 david.h.pauline@wv.gov

Vendor Signature X **FEIN#** 55-0585890 **DATE** 5/27/2026

All offers subject to all terms and conditions contained in this solicitation

ADDITIONAL INFORMATION

The West Virginia Purchasing Division is soliciting bids on behalf of the Adjutant General's Office, Mountaineer Challenge Academy North (MCAN), to establish a one-time purchase contract to provide (2) new combi ovens at Camp Dawson (MCAN Dining Facility) in Kingwood, WV, per the attached specifications, and documents.

INVOICE TO		SHIP TO	
ADJUTANT GENERALS OFFICE 1703 COONSKIN DR		ADJUTANT GENERALS OFFICE 1001 ARMY RD	
CHARLESTON	WV	KINGWOOD	WV
US		US	

Line	Comm Ln Desc	Qty	Unit Issue	Unit Price	Total Price
1	Gas Combi Ovens	2.00000	EA	\$18,172.62	\$36,345.24

Comm Code	Manufacturer	Specification	Model #
48101507	Convotherm	See attached quote for spec	C4 ET 6.20GS-N

Extended Description:
Please refer to the Exhibit "A" Pricing Page to input unit pricing.

SCHEDULE OF EVENTS

<u>Line</u>	<u>Event</u>	<u>Event Date</u>
1	Vendor Technical Questions Due By 11:00 am. EST.	2026-05-19

	Document Phase	Document Description	Page
ADJ2600000021	Final	Ovens for Mountaineer Challenge Academy Dining Facility	3

ADDITIONAL TERMS AND CONDITIONS

See attached document(s) for additional Terms and Conditions



Department of Administration
 Purchasing Division
 2019 Washington Street East
 Post Office Box 50130
 Charleston, WV 25305-0130

State of West Virginia
 Centralized Request for Quote
 Equipment

Proc Folder: 1919880	Reason for Modification: Addendum No. 1
Doc Description: Ovens for Mountaineer Challenge Academy Dining Facility	
Proc Type: Central Purchase Order	

Date Issued	Solicitation Closes	Solicitation No	Version
2026-05-20	2026-05-27 13:30	CRFQ 0603 ADJ2600000021	2

BID RECEIVING LOCATION

BID CLERK
 DEPARTMENT OF ADMINISTRATION
 PURCHASING DIVISION
 2019 WASHINGTON ST E
 CHARLESTON WV 25305
 US

VENDOR

Vendor Customer Code: 203432
Vendor Name : Douglas Equipment
Address : 301
Street : North St
City : Bluefield
State : WV **Country :** US **Zip :** 24701
Principal Contact : Samantha Radford
Vendor Contact Phone: 304-327-2958 **Extension:**

FOR INFORMATION CONTACT THE BUYER

David H Pauline
 304-558-0067
 david.h.pauline@wv.gov

Vendor Signature X **FEIN#** 55-0585890 **DATE** 5/27/2026

All offers subject to all terms and conditions contained in this solicitation

ADDITIONAL INFORMATION

Addendum No. 1

To provide responses to the vendor technical questions, see attached.

Bid opening date and time remains May 27, 2026, at 1:30 pm. EST.

No other changes.

INVOICE TO**SHIP TO**ADJUTANT GENERALS
OFFICE
1703 COONSKIN DRADJUTANT GENERALS
OFFICE
1001 ARMY RDCHARLESTON WV
USKINGWOOD WV
US

Line	Comm Ln Desc	Qty	Unit Issue	Unit Price	Total Price
1	Gas Combi Ovens	2.00000	EA	\$18,172.62	\$36,345.24

Comm Code	Manufacturer	Specification	Model #
48101507	Convothem	See attached quote for Spec	C4 ET 6.20GS-N

Extended Description:

Please refer to the Exhibit "A" Pricing Page to input unit pricing.

SCHEDULE OF EVENTS

<u>Line</u>	<u>Event</u>	<u>Event Date</u>
1	Vendor Technical Questions Due By 11:00 am. EST.	2026-05-19

	Document Phase	Document Description	Page
ADJ2600000021	Final	Ovens for Mountaineer Challenge Academy Dining Facility	3

ADDITIONAL TERMS AND CONDITIONS

See attached document(s) for additional Terms and Conditions