



The following documentation is an electronically-submitted vendor response to an advertised solicitation from the *West Virginia Purchasing Bulletin* within the Vendor Self-Service portal at wvOASIS.gov. As part of the State of West Virginia's procurement process, and to maintain the transparency of the bid-opening process, this documentation submitted online is publicly posted by the West Virginia Purchasing Division at WVPurchasing.gov with any other vendor responses to this solicitation submitted to the Purchasing Division in hard copy format.

Header 1

List View

- General Information
- Contact
- Default Values
- Discount
- Document Information
- Clarification Request

Procurement Folder: 1949548

Procurement Type: Central Purchase Order

Vendor ID: VS0000020707

Legal Name: SABIO ENVIRONMENTAL LLC

Alias/DBA:

Total Bid: \$100,255.00

Response Date: 05/04/2026

Response Time: 16:08

Responded By User ID: sabio2018

First Name: Tim

Last Name: Jackson

Email: tjackson@sabio.com

Phone: 5128690544

SO Doc Code: CRFQ

SO Dept: 0313

SO Doc ID: DEP2600000032

Published Date: 5/4/26

Close Date: 5/7/26

Close Time: 13:30

Status: Closed

Solicitation Description: Multi-Gas Dilution Calibrators w/Ozone Generators

Total of Header Attachments: 1

Total of All Attachments: 1



Department of Administration
 Purchasing Division
 2019 Washington Street East
 Post Office Box 50130
 Charleston, WV 25305-0130

**State of West Virginia
 Solicitation Response**

Proc Folder: 1949548
Solicitation Description: Multi-Gas Dilution Calibrators w/Ozone Generators
Proc Type: Central Purchase Order

Solicitation Closes	Solicitation Response	Version
2026-05-07 13:30	SR 0313 ESR05042600000007588	1

VENDOR
 VS0000020707
 SABIO ENVIRONMENTAL LLC

Solicitation Number: CRFQ 0313 DEP2600000032
Total Bid: 100255
Response Date: 2026-05-04
Response Time: 16:08:58
Comments:

FOR INFORMATION CONTACT THE BUYER

Joseph (Josh) E Hager III
 (304) 558-2306
 joseph.e.hageriii@wv.gov

Vendor Signature X **FEIN#** **DATE**

All offers subject to all terms and conditions contained in this solicitation

Line	Comm Ln Desc	Qty	Unit Issue	Unit Price	Ln Total Or Contract Amount
1	Multi-Gas Dilution Calibrators w/Ozone Generators	6.00000	EA	16700.000000	100200.00

Comm Code	Manufacturer	Specification	Model #
49241708			

Commodity Line Comments:

Extended Description:

Multi-Gas Dilution Calibrators w/Ozone Generators

Line	Comm Ln Desc	Qty	Unit Issue	Unit Price	Ln Total Or Contract Amount
2	Shipping charges	1.00000	EA	55.000000	55.00

Comm Code	Manufacturer	Specification	Model #
78121603			

Commodity Line Comments:

Extended Description:

Shipping charges



Sabio

Environmental *ambient pollution analyzers and calibration systems*

Model 4010S Multi-gas Dilution Calibrator

The Model 4010M is a simple, but powerful Intelligent Multi-gas Dilution Calibrator that can easily perform gas dilution, multi-source gas blending, ozone generation, and gas phase titration (GPT = NO + O3 => NO2) for environmental, laboratory, or point source monitoring.



The Multi-gas system is designed to be either sequence based (gases are established, gases are assigned to source input ports, desired dilution flow defined, and output concentrations are established), or the unit can be manually controlled by the operator from the status window. Flexibility, without complicated menu systems or restrictions allow the operator to fully control the calibrator for various applications.

Users can easily navigate the menu system for setup or to check various parameters while the unit is idle or actively running. Flexibility allows any operator to easily start or stop an operation sequence, manually adjust flows while an operation is active, change ozone concentration, open/close source valves, manually purge the gas system while in operation, or view all active parameters from one simple status window. The status window will display the dilution of all gases present when using a multi-blend cylinder or the value of NO₂ generated during GPT. Additionally, users can switch from one sequence to another without stopping the entire system for seamless transition during testing.

The Model 4010M calibrator uses embedded microprocessor technology to precisely deliver and control gas concentrations along multiple curve fits to linearize the desired output for the intended application. The pneumatic system uses Mass Flow Controllers (MFC's) to precisely meter gas streams and implement multiple curve correction algorithms to deliver precise and repeatable concentrations.

The optional precision ozone generator allows the user to generate reliable, repeatable, and stable ozone for calibrating ozone analyzers or for creating NO₂ using gas phase titration for NO_x analyzers. The stable and consistent ozone output eliminates the need for complicated and time-consuming ozone adjustments prior to GPT operation.

Users can measure the ozone concentration from the internal ozone generator with Sabio's optional internal ozone photometer or measure external ozone sources by manually activating the photometer or setting the photometer to continuous monitor mode. Alternatively, the internal ozone photometer can be used to control the ozone output while actively measuring the concentration using the ozone servo control mode.

The Sabio Multi-gas Dilution Calibrator design exceeds US EPA calibration method requirements. Dilution components are calibrated with standards and test equipment traceable to the National Institute of Standards and Technology.

Specifications

Specifications subject to change without notice

Dilution System	Input Dilution Gases	1 Standard (2 Optional)
	Input Source Gases	4 Standard, 1 Purge, Optional 2 Additional
	Output Manifold	6 Outputs Standard, Optional 2 Additional
	Dilution Mass Flow Controller	0-10 SLM, Optional Ranges 0-20 SLM
	Source Mass Flow Controller	0-100 SCCM, Optional Ranges 0-2000 SCCM
	2nd Source Mass Flow Controller	0-100 SCCM, Optional Ranges 0-2000 SCCM
	Input Pressure	15-45 PSI
	Flow Accuracy	$\leq \pm 0.2\%$ Full Scale
	Flow Repeatability	$\leq \pm 0.15\%$ Full Scale
	Linearity	$\leq \pm 0.5\%$ Full Scale
	Response Time at Output	< 1 Minute
Optional Internal Ozone Generator	Output (Standard)	0-1000ppb, Max-6 ppm Flexcal
	Accuracy	$\pm 1\%$ of Set Point or ± 1 ppb @ 5 SLM
	Nominal Flow	100 SCCM, ± 1 SCCM
	UV Lamp Temperature	50 °C, ± 0.1 °C
	Reaction Chamber	Teflon standard or Glass (optional)
Optional UV Absorption Photometer	Standard Ranges	0-0.5, 1.0, 2.0 ppm
	Linearity	$< \pm 1$ ppb or 0.5% of full scale
	Precision	< 1 ppb
	Zero Drift	< 1 ppb for 24 hours
	Flow Rate	1 Liter (nominal)
	Analog Output	3 Ranges: 5V, 1V, Optional 100mV
	Response Time	< 180 Seconds to 95% (system)
	Rise/Fall Time	< 20 Seconds (photometer)
Optional Internal Permeation Oven	Chamber Materials	Glass or Teflon
	Chamber Size	XXXXX
	Adjustable Temperature	5 °C Above Ambient Temperature to 65 °C
	Temperature Accuracy	$\leq \pm 0.1$ °C
Calibrator Interface	Operation	47 Button Membrane Keypad display 25-line x 80-character, Keyboard, Serial, USB, Ethernet
	Calibration Definitions	20 User defined calibration sequences
	Calibration Types	Gas Dilution, Ozone, GPT, Multi-gas, Multi-blend, Permeation
	Gas Definitions	2 Diluent Gases, 20 Sources Gases
	Auto Calibrations	20 timer driven cal routines that perform user-defined calibration sequences on a 7-day calendar of event
	Digital Inputs	8 Status I/O bits for calibrator functions, Optional 24 bits
	Digital Input Types	Contact Closure or TTL Logic
	Digital Outputs	8 Status Outputs bits for monitoring calibrator functions, Optional 24 bits
	Communications	RS232, Ethernet 10/100 Base-T, USB
Calibrator System	Operating Temperature	0 °C to 40 °C
	Dimensions	4010M 7.00" (17.8 cm) H x 16.2" (41.2 cm) W x 15" (38.1cm)D
	Base Unit Weight	20 lbs. (9.1 kg)
	Input Voltage	98-264 VAC, 150-300 VA, 50/60 HZ

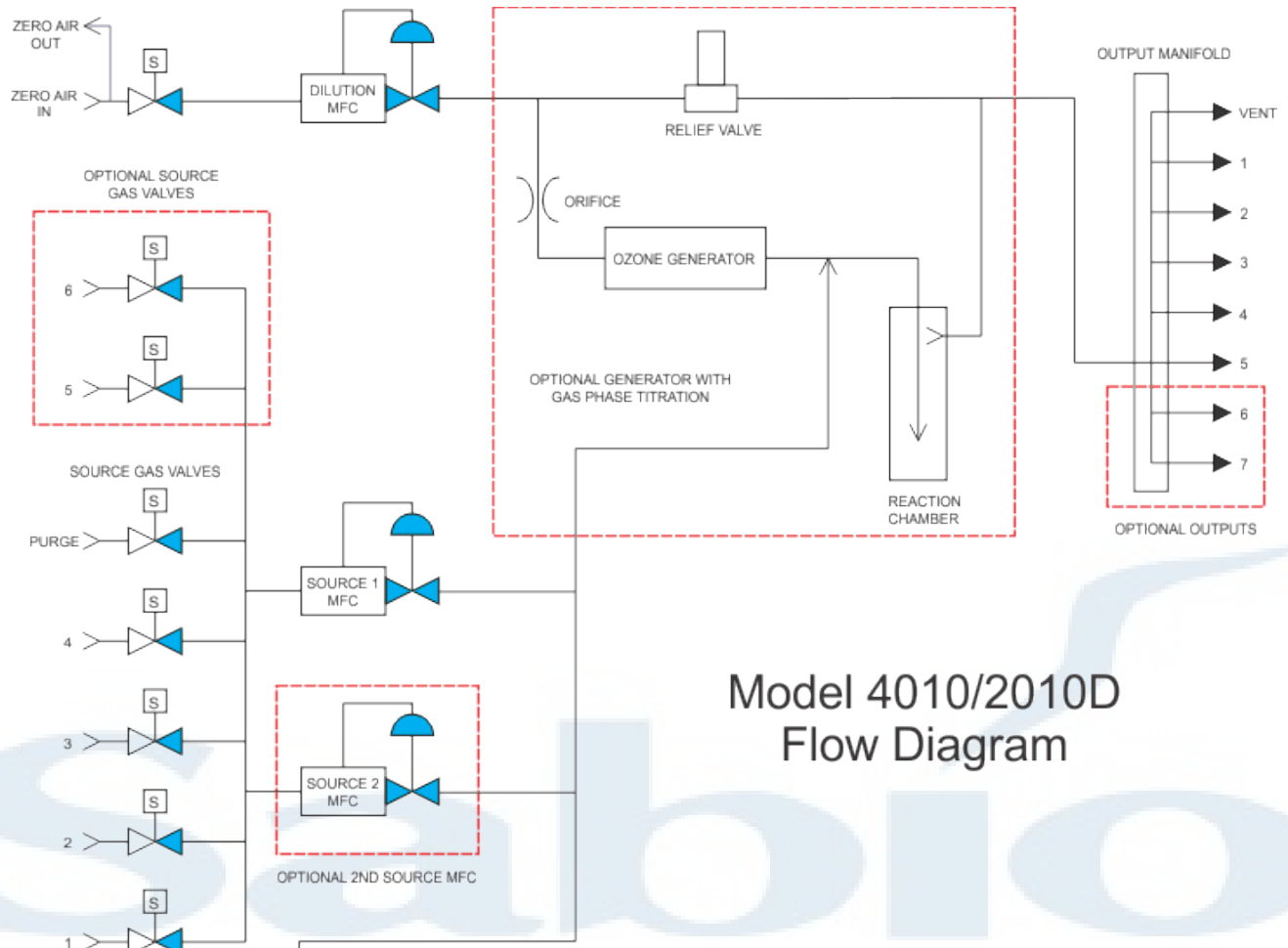

Model 4010/2010D Flow Diagram

Additional Options and Features Available

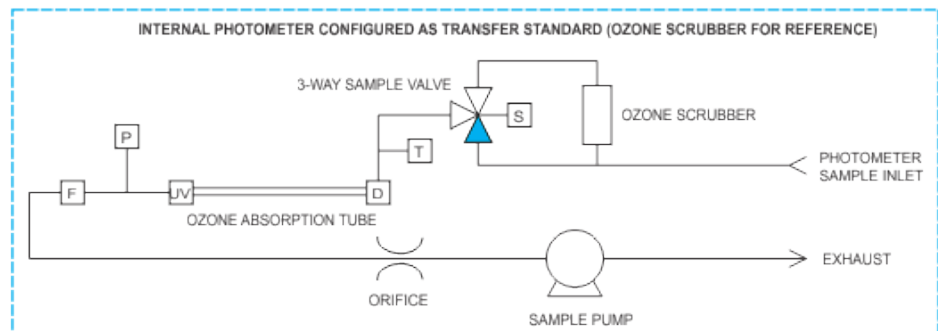
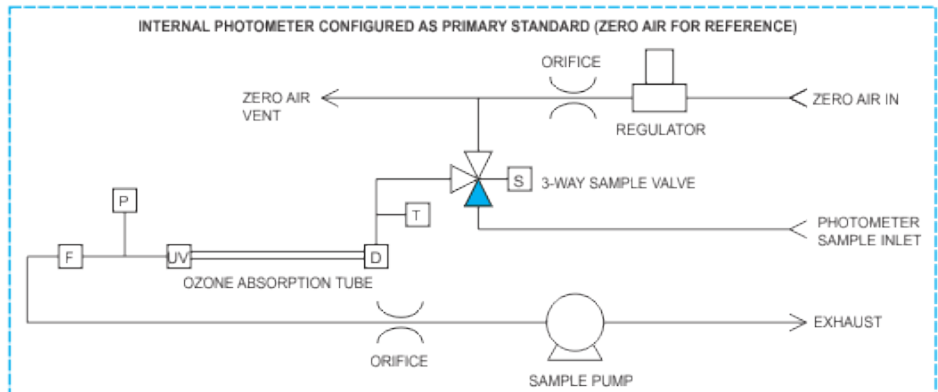

Sabio Environmental, LLC
21 Cypress Blvd Suite 1130
Round Rock, TX 78665

PH: 512.869.0544
sales@sabio.com
www.sabio.com