



The following documentation is an electronically-submitted vendor response to an advertised solicitation from the *West Virginia Purchasing Bulletin* within the Vendor Self-Service portal at *wvOASIS.gov*. As part of the State of West Virginia's procurement process, and to maintain the transparency of the bid-opening process, this documentation submitted online is publicly posted by the West Virginia Purchasing Division at *WVPurchasing.gov* with any other vendor responses to this solicitation submitted to the Purchasing Division in hard copy format.

Header 3

List View

- General Information**
- Contact
- Default Values
- Discount
- Document Information
- Clarification Request

Procurement Folder: 1297303

Procurement Type: Central Master Agreement

Vendor ID:

Legal Name: Monmouth Solutions, Inc

Alias/DBA: Monmouth Solutions, Inc

Total Bid: \$4,474,725.00

Response Date:

Response Time:

Responded By User ID:

First Name:

Last Name:

Email:

Phone:

SO Doc Code: CRFQ

SO Dept: 0803

SO Doc ID: DOT2400000039

Published Date: 11/17/23

Close Date: 11/28/23

Close Time: 13:30

Status: Closed

Solicitation Description:

Total of Header Attachments: 3

Total of All Attachments: 3



Department of Administration
Purchasing Division
2019 Washington Street East
Post Office Box 50130
Charleston, WV 25305-0130

**State of West Virginia
Solicitation Response**

Proc Folder: 1297303
Solicitation Description: ADDENDUM NO_2 Rubber Tired Wheel Loader 4 wh. drive
Proc Type: Central Master Agreement

Solicitation Closes	Solicitation Response	Version
2023-11-28 13:30	SR 0803 ESR11272300000002519	1

VENDOR
VS0000041955
Monmouth Solutions, Inc

Solicitation Number: CRFQ 0803 DOT2400000039
Total Bid: 4474725
Response Date: 2023-11-27
Response Time: 16:28:58
Comments:

FOR INFORMATION CONTACT THE BUYER
John W Estep
304-558-2566
john.w.estep@wv.gov

Vendor
Signature X **FEIN#** **DATE**

All offers subject to all terms and conditions contained in this solicitation

Line	Comm Ln Desc	Qty	Unit Issue	Unit Price	Ln Total Or Contract Amount
1	Rubber Tired Wheel Loader 4 wh. drive	25.00000	EA	178989.000000	4474725.00

Comm Code	Manufacturer	Specification	Model #
22101501			

Commodity Line Comments: Unit is on the ground and can be delivered within 2-4 weeks ARO.

Extended Description:

Rubber Tired Wheel Loader 4 wh. drive

**UEI: E474YENAVPB7 | CAGE: 9DMG0 |
SDVOSB CERT #: VSBC-52457208749**



MONMOUTH SOLUTIONS PROPOSAL

REVOLUTIONIZING GOVERNMENT
PROCUREMENT, ONE SOLUTION AT A TIME.



MONMOUTH
SOLUTIONS
INC.

ABOUT US

Monmouth Solutions, INC is a Service-Disabled Veteran owned Small Business that was formed in 2022 with a focus on logistic coordination, disaster relief, metal/steel manufacturing, equipment rentals, and much more. As a disabled veteran owned business, we know firsthand how important it is for vendors to offer fast, effective, and efficient products and services to the Federal Government. Monmouth Solutions consists of industry leaders with almost a century of combined experience. Our focus is providing effective products and services at the best price. Members of Monmouth have provided services to just about every sector of the federal government. These include but are not limited to the Armed Forces, DHS, VA, and GSA.

CORE COMPETENCIES

- Trailer Manufacturing
- Logistic Support
- Disaster Relief
- Rental Vehicle Solutions
- Waste/Shipping Container Manufacturing
- Mobile Office/Lab Solutions
- Mobile Housing Solutions
- Lodging Solutions
- Heavy/Small Equipment Rentals
- Specialty Vehicle Manufacturing

POINTS OF CONTACT

John Mercuri

CEO

jj@monmouthsolutions.com

978-427-4755

Michael Mercuri

Owner

michael@monmouthsolutions.com

617-593-1686

NAICS

- 336214** - Travel Trailer and Camper Manufacturing
- 811121** - Automotive Body, Paint, and Interior Repair and Maintenance
- 532111** - Passenger Car Rental
- 336212** - Truck Trailer Manufacturing
- 332439** - Other Metal Container Manufacturing
- 532412** - Construction, Mining, and Forestry Machinery and Equipment Rental and Leasing
- 532490** - Other Commercial and Industrial Machinery and Equipment Rental and Leasing
- 541611** - Administrative Management and General Management Consulting Services
- 721110** - Hotels (except Casino Hotels) and Motels
- 722320** - Caterers
- 811310** - Commercial and Industrial Machinery and Equipment (Except Automotive and Electronic) Repair and Maintenance
- 336211** - Motor Vehicle Body Manufacturing
- 333120** - Construction Machinery Manufacturing

PAST PERFORMANCE

- Enclosed Trailers (DOT, DOI, BLM, ARMY)
- Dumpster and other refuse container manufacturing (D.O.E)
- Logistical solutions (BLM, DOT)
- Boats and trailers (BLM)
- Rental of Heavy equipment (BLM, DOD)
- Rental of Mobile office space (DOT, DOI)
- COVID-19 relief (FEMA)
- Hurricane Ian Relief (FEMA)
- Passenger Vehicle Rental (AF)



FEMA



US Army Corps
of Engineers.



SERVICE-DISABLED
VETERAN-OWNED
CERTIFIED

MONMOUTH SOLUTIONS PROPOSAL

RUBBER TIRED WHEEL LOADER

SOLICITATION #: CRFQ-0803-DOT2400000039-3

Monmouth Solutions will provide and deliver a 2023 Liugong 835HV Wheel Loader to the address specified by the buyer.

About Us:

Monmouth Solutions, Inc. is a well-established Service-Disabled Veteran-Owned Small Business (SDVOSB) with a history of providing innovative solutions to state, local, and federal government agencies.

Experience and Expertise:

Our team boasts a rich history of successfully completing similar contracts. This includes providing individual orders of single units to small and local government agencies all the way providing extensive fleets of custom equipment to large government agencies such as Air Force and Army Bases worldwide.

Logistics Excellence:

With our co-owners also leading **Horizon Air Freight**, they bring extensive logistical expertise to the table, ensuring efficient and timely delivery of equipment, even in challenging situations. Overall, this synergy allows us to offer rapid turnaround deliveries, ensuring that the required units are efficiently transported to the project site, minimizing delays, and maximizing operational efficiency.

Proposal Overview (KEY POINTS):

Product Quality: We commit to providing equipment that adheres to the requested specifications, guaranteeing exceptional quality, durability, and long-term performance.

Diverse Range: Our comprehensive equipment offerings cover a variety of sizes and categories.

Delivery Efficiency: Thanks to our integrated logistics capabilities, we are confident in our ability to provide prompt and reliable delivery of the units to the project site.

Proven Performance: Our outstanding track record in delivering & operating similar equipment to and for government agencies reflects our dedication to exceeding expectations and delivering on time and within budget.

Collaborative Approach: We look forward to collaborating closely with your team to ensure seamless communication, efficient project management, and successful execution.

LIUGONG
NORTH AMERICA

835Hv

WHEEL LOADER

ENGINE
Cummins
B4.5

OPERATING WEIGHT
28,053 lb
(12,725 kg)

GROSS POWER
154 hp
(115 kW)

BUCKET SIZE
2.5 yd³
(1.9 m³)



SPECIFICATIONS

ENGINE

Emissions rating	EPA Tier 4 Final / EU Stage V
Make	Cummins
Model	B4.5
Gross power	154 hp (115 kW) @ 2,200 rpm
Net power	142 hp (106 kW) @ 2,200 rpm
Peak torque	525 lbf-ft (712 N·m) @ 1,200 rpm
Cylinders	4
Displacement	1.18 gal (4.5 L)
Aspiration	Turbocharged & Air-to-air intercooled

TRANSMISSION

Transmission type	Countershaft, power shift
Torque converter	Single stage, three elements
Max. travel speed, fwd	23.6 mph (38 km/h)
Max. travel speed, rev	15.9 mph (25.6 km/h)
Number of speeds, fwd	4
Number of speeds, rev	3

AXLES

Differential front type	Limited slip
Differential rear type	Limited slip
Axle oscillation	±12°

STEERING

Steering configuration	Articulated
Steering pressure	2,611 psi (18 Mpa)

BRAKES

Service brake type	Wet disc brake
Service brake actuation	Fully hydraulic
Parking brake type	Drum
Parking brake actuation	Electro-hydraulic release

HYDRAULIC SYSTEM

Main pump type	Piston
System pressure	3,771 psi (26 MPa)
Raise	4.8 s
Dump time	1.5 s
Float down time	3.1 s
Total cycle time	9.4 s

BUCKET PERFORMANCE

Bucket capacity	2.0-5.2 yd ³ (1.5-4.0 m ³)
-----------------	---

TIRES

Tire size	17.5R25 L3
-----------	------------

OPERATING WEIGHT

Operating weight	28,053 lb (12,725 kg)
------------------	-----------------------

SERVICE CAPACITY

Fuel tank	57.3 gal (217 L)
Engine oil	3 gal (11.6 L)
Cooling system	7.4 gal (28 L)
Hydraulic system	33 gal (125 L)
Transmission	10.5 gal (40 L)
Axles, each	9 gal (34 L)
DEF tank	5 gal (19 L)

SPECIFICATIONS

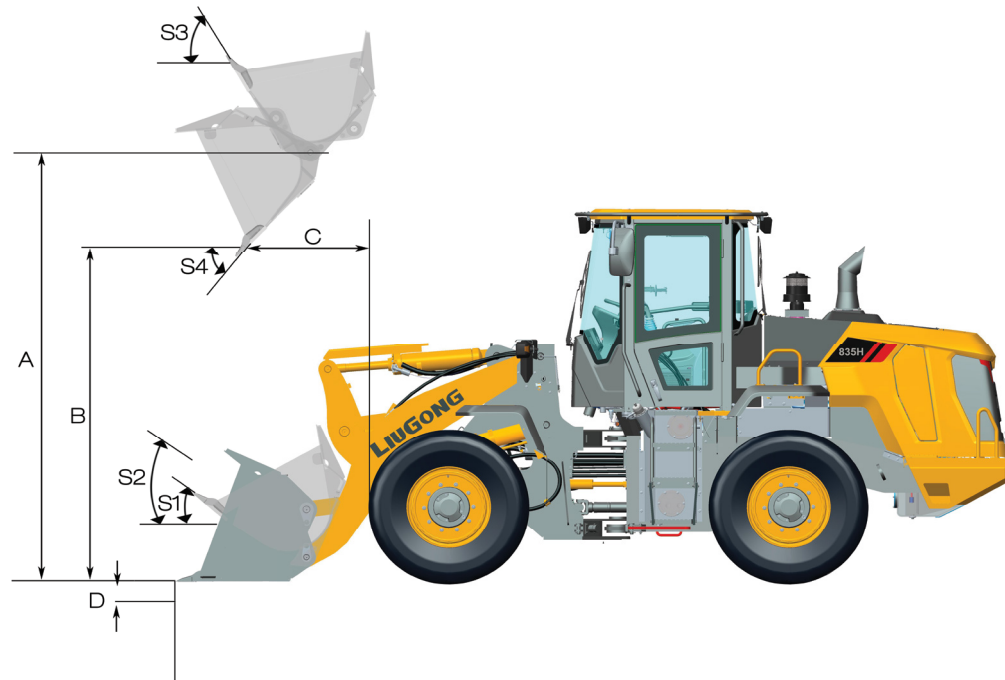

LOADER ARM PERFORMANCE WITH ATTACHMENT

Description

Tipping load - straight	19,522 lb (8,855 kg)
Tipping load - full turn	16,480 lb (7,475 kg)
Bucket breakout force	20,233 lbf (90 kN)
A Maximum hinge pin height	12 ft 3 in (3,738 mm)
B Dump clearance at full height discharge	8 ft 9 in (2,680 mm)
C Dump reach at full height discharge	3 ft 10 in (1,168 mm)
D Max. digging depth, bucket level	2.3 in (60 mm)
S ₁ Bucket rollback at ground level	42°
S ₂ Bucket rollback at carry	49°
S ₃ Bucket rollback at max. height	56°
S ₄ Max. dump angle at full height	45°

SPECIFICATIONS

EXCLUSIVELY FOR DEALER

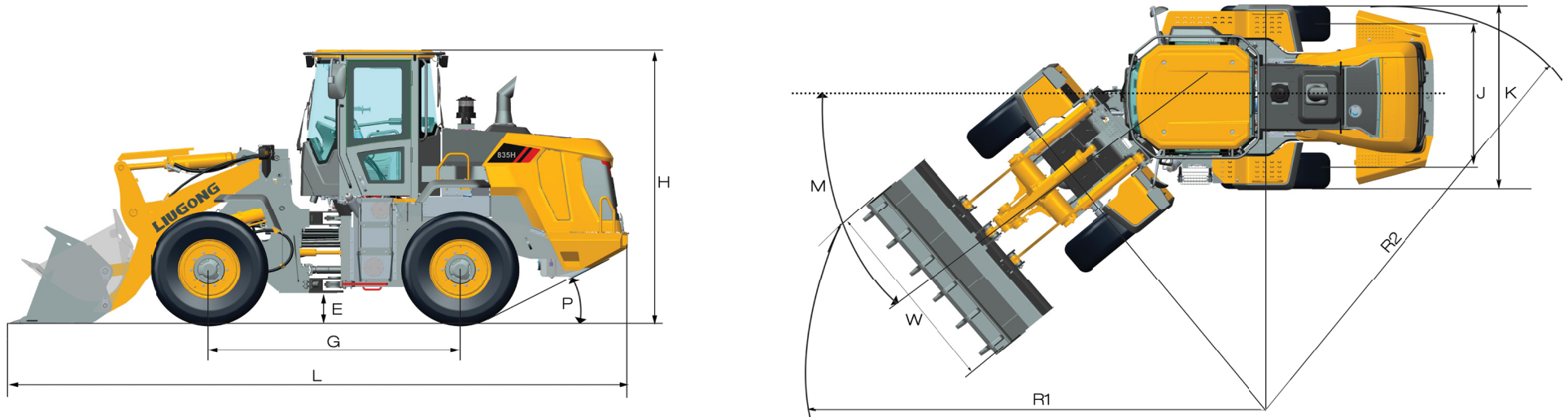

DIMENSIONS

Description

E	Ground clearance	1 ft 4 in (400 mm)
G	Wheelbase	9 ft 7 in (2,940 mm)
H	Cab height	11 ft 1 in (3,370 mm)
J	Wheel tread	6 ft 3 in (1,910 mm)
K	Width over tires	7 ft 9 in (2,355 mm)
L	Length with bucket down	24 ft 1 in (7,347 mm)
M	Turn angle, either side	40°
P	Rear angle of departure	31°
R ₁	Turning radius, bucket carry	19 ft 1 in (5,807 mm)
R ₂	Turning radius, outside of tire	17 ft 5 in (5,313 mm)
W	Width over bucket	8 ft 1 in (2,460 mm)

LGNA-SS-835HV-202207-ENG-US

Specifications and designs are subject to change without notice.
Machines shown may include optional equipment.

Liugong Construction Machinery N.A., LLC.
22220 Merchants Way - Suite 100
Katy, TX 77449
USA

T: 281-579-8882
www.liugongna.com

F: 281-579-8388

PRICING

2023 LIUGONG 835HV

\$178,989.00

**ALL DELIVERY AND OTHER FEES
INCLUDED IN OUR PRICING.**

POC:

John Mercuri - CEO

(978) 735 - 3855

jj@monmouthsolutions.com

93 Butman Rd, Lowell, MA 01852

Cage: 9DMG0

UEI: E474YENAVPB7

SDVOSB: VSBC-52457208749



MONMOUTH
SOLUTIONS
INC.

UEI: E474YENAVPB7 | CAGE: 9DMG0 |
SDVOSB CERT #: VSBC-52457208749





Department of Administration
 Purchasing Division
 2019 Washington Street East
 Post Office Box 50130
 Charleston, WV 25305-0130

State of West Virginia
 Centralized Request for Quote
 Equipment

Proc Folder: 1297303		Reason for Modification:	
Doc Description: ADDENDUM NO_2 Rubber Tired Wheel Loader 4 wh. drive		ADDENDUM NO_2 Vendor Questions and Responses	
Proc Type: Central Master Agreement			
Date Issued	Solicitation Closes	Solicitation No	Version
2023-11-17	2023-11-28 13:30	CRFQ 0803 DOT2400000039	3

BID RECEIVING LOCATION

BID CLERK
 DEPARTMENT OF ADMINISTRATION
 PURCHASING DIVISION
 2019 WASHINGTON ST E
 CHARLESTON WV 25305
 US

VENDOR

Vendor Customer Code: V50000041955

Vendor Name: Monmouth Solutions, Inc

Address: 93 Butman Rd

Street:

City: Lowell

State: MA **Country:** US **Zip:** 01852

Principal Contact: John Mercuri

Vendor Contact Phone: 978-735-3855 **Extension:**

FOR INFORMATION CONTACT THE BUYER

John W Estep
 304-558-2566
 john.w.estep@wv.gov

Vendor Signature X 

FEIN# 92-0527019 **DATE** 11/27

All offers subject to all terms and conditions contained in this solicitation

ADDITIONAL INFORMATION**ADDENDUM NO_2**

Addendum No_2 issued to publish and distribute the attached information to the Vendor Community.

REQUEST FOR QUOTATION:

The West Virginia Purchasing Division is soliciting bids on behalf of West Virginia Division of Highways to establish an open-end contract for a 4 Wheel Drive, Rubber Tired Wheel Loader Liugong 835Hv with Bucket or equal. Per the Bid Requirements, Specifications, Terms and Conditions attached to this solicitation.

INVOICE TO		SHIP TO	
DIVISION OF HIGHWAYS EQUIPMENT DIVISION RT 33 83 BRUSHY ROAD CROSSING, PO BOX 610 BUCKHANNON WV US		DIVISION OF HIGHWAYS EQUIPMENT DIVISION 83 BRUSHY FORK RD CROSSING BUCKHANNON WV US	

Line	Comm Ln Desc	Qty	Unit Issue	Unit Price	Total Price
1	Rubber Tired Wheel Loader 4 wh. drive	25.00000	EA		

Comm Code	Manufacturer	Specification	Model #
22101501			

Extended Description:

Rubber Tired Wheel Loader 4 wh. drive

SCHEDULE OF EVENTS

Line	Event	Event Date
1	Pre-Bid 10:00am Equip Division, Buckhannon WV	2023-11-09
2	Tech Questions due by 10:00am	2023-11-16

	Document Phase	Document Description	Page 3
DOT2400000039	Final	ADDENDUM NO_2 Rubber Tired Wheel Loader 4 wh. drive	

ADDITIONAL TERMS AND CONDITIONS

See attached document(s) for additional Terms and Conditions

ADDITIONAL INFORMATION

ADDENDUM NO_2

Addendum No_2 issued to publish and distribute the attached information to the Vendor Community.

REQUEST FOR QUOTATION:

The West Virginia Purchasing Division is soliciting bids on behalf of West Virginia Division of Highways to establish an open-end contract for a 4 Wheel Drive, Rubber Tired Wheel Loader Liugong 835Hv with Bucket or equal. Per the Bid Requirements, Specifications, Terms and Conditions attached to this solicitation.

INVOICE TO

DIVISION OF HIGHWAYS
EQUIPMENT DIVISION RT 33
83 BRUSHY ROAD
CROSSING, PO BOX 610
BUCKHANNON WV
US

SHIP TO

DIVISION OF HIGHWAYS
EQUIPMENT DIVISION
83 BRUSHY FORK RD
CROSSING
BUCKHANNON WV
US

Line	Comm Ln Desc	Qty	Unit Issue	Unit Price	Total Price
1	Rubber Tired Wheel Loader 4 wh. drive	25.00000	EA		

Comm Code	Manufacturer	Specification	Model #
22101501			

Extended Description:

Rubber Tired Wheel Loader 4 wh. drive

SCHEDULE OF EVENTS

Line	Event	Event Date
1	Pre-Bid 10:00am Equip Division, Buckhannon WV	2023-11-09
2	Tech Questions due by 10:00am	2023-11-16

SOLICITATION NUMBER: CRFQ DOT2400000039

Addendum Number: 2

The purpose of this addendum is to modify the solicitation identified as CRFQ DOT2400000039 ("Solicitation") to reflect the change(s) identified and described below.

Applicable Addendum Category:

- Modify bid opening date and time
- Modify specifications of product or service being sought
- Attachment of vendor questions and responses
- Attachment of pre-bid sign-in sheet
- Correction of error
- Other

Additional Documentation:

Vendor Questions and Responses

Bid Opening remains 11/28/2023 at 1:30pm

Terms and Conditions:

1. All provisions of the Solicitation and other addenda not modified herein shall remain in full force and effect.
2. Vendor should acknowledge receipt of all addenda issued for this Solicitation by completing an Addendum Acknowledgment, a copy of which is included herewith. Failure to acknowledge addenda may result in bid disqualification. The addendum acknowledgement should be submitted with the bid to expedite document processing.

Tech questions DOT24*39

3.1.8.1 - Unit shall have 120-amp alternator minimum with internal regulator.

Would the State accept a 90-amp alternator? This is the OEM standard and is capable of running all machine electronics and any add-ons the State would happen to add.

Answer: Will accept 90-amp alternator

3.2.6.1 - The bid shall include a breakdown of the complete manufacturer's warranty per section.

We ask that the State set a benchmark for warranty. Our standard manufacturer's warranty is 3-yr/4,000-hr standard & 5-yr/7,000-hr powertrain & hydraulics. This warranty is built into the retail price of the unit and is one of the most comprehensive in the industry. We feel as though we will be penalized monetarily for offering a better product, standard.

Answer: The purpose and scope section of the spec calls out a specific model and brand that will be used as a comparison for an or equal. The or equal covers all aspects of what shall be met at a minimum, including warranty coverage unless an exemption is given by the WVDOH.

3.1.1.5 Is a 24'5" maximum overall length acceptable.

Answer: Will accept up to 24' 8" overall length with bucket on the ground.

3.1.2.1 Is an EPA Final Tier 4 engine acceptable.

Answer: Will accept final tier 4.

3.1.7.3 Are (2) 700 CCA batteries acceptable.

Answer: Will accept two 700CCA batteries.

3.1.14.7 What does "Unit shall be electric over hydraulic control referring to".

Answer: Referring to the use of electrical solenoids on the hydraulic valve to control the hydraulic spools to change direction of liquid flow in the hydraulic valve for bucket operation.

3.1.15.2 Are 20.5/R25 tires acceptable.

Answer: Will accept either 17.5/R25 or 20.5/R25

3.1.1.4 Unit shall have a breakout force of 20,000 pounds minimum. - Would you allow a breakout force of 16,000 pounds?

Answer: No leave as written.

3.1.2.2 Engine shall be a minimum net power rating would 142 hp. - Would you allow minimum hp requirement of engine to be 120 hp?

Answer: No leave as written.

3.1.14.4 Hydraulic system relief pressure shall be 3755 PSI minimum. - Would you allow hydraulic system relief shall be 3600 PSI minimum?

Answer: Will accept 3600PSI.

3.1.1.8 Would you allow a 98" dumping clearance at maximum height and 45- degree dump angle?

Answer: Will accept.

Question 1 – 3.1.1.5 Overall length (bucket on ground) shall be 24-foot-2-inch maximum.

Our machine is 24' 5" with coupler and bucket. Will you accept?

Answer 1 – Will accept a maximum 24' 8" overall length with bucket down.

Question 2 – 3.1.6.1 Complete aluminized exhaust system shall be manufacturer's standard for unit specified.

Can you please clarify this? Will CAT's standard exhaust system suffice?

Answer 2 – Will accept manufacturers standard exhaust system.

Question 3 – 3.1.8.1 Unit shall have 120-amp alternator minimum with internal regulator.

Our machine comes standard with a 115-amp alternator. Will you accept?

Answer 3 – Will accept 90 amps and above alternator output.

Question 4 – 3.1.12.1 Axles should be ZF.

ZF is an aftermarket brand axle. Will you accept a CAT branded axle?

Answer 4 – Will accept manufacturer branded axles if the warranty coverage is an or equal to the base warranty for the model covered in the purpose and scope section.

Question 5 – 3.1.15.2 Tires shall be correct ply and rating grader/loader type front and rear tubeless radials 17.5/R25 size 1-star L-3

The standard size for our loader is 20.5/R25. Will you accept?

Answer 5 – Will accept 17.5/R25 or 20.5/R25.

Question 6 – 3.1.19.7 Bucket shall have lifting eyes on left and right side and center of bucket.

It is not common industry practice to have lift eyes on a wheel loader bucket. It would require welding on lift eyes, which then creates other complications, such as safety certifying the lift eyes. This is nearly impossible without knowing the specific applications that these would be used for. Will you consider removing this spec?

Answer 6 – Will remove

ADDENDUM ACKNOWLEDGEMENT FORM
SOLICITATION NO.: CRFO DOT240000039

Instructions: Please acknowledge receipt of all addenda issued with this solicitation by completing this addendum acknowledgment form. Check the box next to each addendum received and sign below. Failure to acknowledge addenda may result in bid disqualification.

Acknowledgment: I hereby acknowledge receipt of the following addenda and have made the necessary revisions to my proposal, plans and/or specification, etc.

Addendum Numbers Received:

(Check the box next to each addendum received)

- | | |
|--|--|
| <input checked="" type="checkbox"/> Addendum No. 1 | <input type="checkbox"/> Addendum No. 6 |
| <input checked="" type="checkbox"/> Addendum No. 2 | <input type="checkbox"/> Addendum No. 7 |
| <input type="checkbox"/> Addendum No. 3 | <input type="checkbox"/> Addendum No. 8 |
| <input type="checkbox"/> Addendum No. 4 | <input type="checkbox"/> Addendum No. 9 |
| <input type="checkbox"/> Addendum No. 5 | <input type="checkbox"/> Addendum No. 10 |

I understand that failure to confirm the receipt of addenda may be cause for rejection of this bid. I further understand that that any verbal representation made or assumed to be made during any oral discussion held between Vendor's representatives and any state personnel is not binding. Only the information issued in writing and added to the specifications by an official addendum is binding.

Manmouth Solutions, Inc

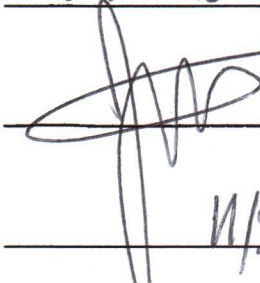
Company

Authorized Signature
11/27

Date

NOTE: This addendum acknowledgement should be submitted with the bid to expedite document processing.

EXHIBIT B

EQUIPMENT PREVENTATIVE MAINTENANCE QUESTIONNAIRE

THIS FORM MUST BE COMPLETED IN ITS ENTIRETY BY SUCCESSFUL BIDDER OR MANUFACTURER'S TECHNICAL REPRESENTATIVE PRIOR TO DELIVERY TO THE WVDOH.

DESCRIPTION: 2023 MAKE: Liugang
MODEL: 8354V YEAR: 2023 PURCHASE AMOUNT: \$178,989.00
ENGINE: MAKE: Cummins MODEL: B4.5 FUEL TYPE: ULSD GALLONS:
HORSEPOWER: 154Hp CYLINDER: 4.5 ENGINE SERIAL: will provide w/ award

BELTS: DESCRIPTION: PART NUMBERS:

DIMENSIONS OF UNIT: LENGTH: 24'3" WIDTH: HEIGHT: 11'4"

VENDOR CONTACT PERSON: John Mercuri PHONE: 978 735-3855

PARTS:

BATTERY MAKE: MODEL: CCA:
SPARK PLUGS OR FUEL INJECTORS MAKE: PART #
FUEL PUMP OR INJECTION PUMP MAKE: MODEL:
ALTERNATOR MAKE: PART #:
STARTER MAKE: PART #:
TURBO CHARGER MAKE: PART #:
TRANS. MAKE: MODEL: AUTO/MANUAL:
HYDRAULIC PUMP MAKE: MODEL:

Table with 5 columns: FILTERS, MAKE, PART NO., LUBRICANT, MANUFACTURER TYPE. Rows include OIL, AIR INNER, AIR OUTER, FUEL PRIMARY, FUEL SECONDARY, COOLANT, HYDRAULIC, OTHER.

spec sheet attached

REQUEST FOR QUOTATION
(Class 353) 4 Wheel Drive Rubber Tired Wheel Loader Liugong 835Hv with
Bucket or equal.

- 7.1.2 Failure to comply with other specifications and requirements contained herein.
- 7.1.3 Failure to comply with any laws, rules, and ordinances applicable to the Contract Services provided under this Contract.
- 7.1.4 Failure to remedy deficient performance upon request.
- 7.2 The following remedies shall be available to Agency upon default.
 - 7.2.1 Immediate cancellation of the Contract.
 - 7.2.2 Immediate cancellation of one or more release orders issued under this Contract.
 - 7.2.3 Any other remedies available in law or equity.

8. MISCELLANEOUS:

- 8.1 **No Substitutions:** Vendor shall supply only Contract Items submitted in response to the Solicitation unless a contract modification is approved in accordance with the provisions contained in this Contract.
- 8.2 **Reports:** Vendor shall provide quarterly reports and annual summaries to the Agency showing the Agency's items purchased, quantities of items purchased, and total dollar value of the items purchased. Vendor shall also provide reports, upon request, showing the items purchased during the term of this Contract, the quantity purchased for each of those items, and the total value of purchases for each of those items. Failure to supply such reports may be grounds for cancellation of this Contract.
- 8.3 **Contract Manager:** During its performance of this Contract, Vendor must designate and maintain a primary contract manager responsible for overseeing Vendor's responsibilities under this Contract. The Contract manager must be available during normal business hours to address any customer service or other issues related to this Contract. Vendor should list its Contract manager and his or her contact information below.

Contract Manager: John Mercuri
Telephone Number: 978-735-3855
Fax Number: _____
Email Address: jj@monmouthsolutions.com

DESIGNATED CONTACT: Vendor appoints the individual identified in this Section as the Contract Administrator and the initial point of contact for matters relating to this Contract.

(Printed Name and Title) John Mercuri / CEO

(Address) 93 Butman Rd Lowell, MA 01852

(Phone Number) / (Fax Number) 978-735-3955

(email address) jje@monmouthsolutions.com

CERTIFICATION AND SIGNATURE: By signing below, or submitting documentation through wvOASIS, I certify that: I have reviewed this Solicitation/Contract in its entirety; that I understand the requirements, terms and conditions, and other information contained herein; that this bid, offer or proposal constitutes an offer to the State that cannot be unilaterally withdrawn; that the product or service proposed meets the mandatory requirements contained in the Solicitation/Contract for that product or service, unless otherwise stated herein; that the Vendor accepts the terms and conditions contained in the Solicitation, unless otherwise stated herein; that I am submitting this bid, offer or proposal for review and consideration; that this bid or offer was made without prior understanding, agreement, or connection with any entity submitting a bid or offer for the same material, supplies, equipment or services; that this bid or offer is in all respects fair and without collusion or fraud; that this Contract is accepted or entered into without any prior understanding, agreement, or connection to any other entity that could be considered a violation of law; that I am authorized by the Vendor to execute and submit this bid, offer, or proposal, or any documents related thereto on Vendor's behalf; that I am authorized to bind the vendor in a contractual relationship; and that to the best of my knowledge, the vendor has properly registered with any State agency that may require registration.

By signing below, I further certify that I understand this Contract is subject to the provisions of West Virginia Code § 5A-3-62, which automatically voids certain contract clauses that violate State law; and that pursuant to W. Va. Code 5A-3-63, the entity entering into this contract is prohibited from engaging in a boycott against Israel.

Monmouth Solutions, Inc
(Company)

(Signature of Authorized Representative)

John Mercuri / CEO / 11/27
(Printed Name and Title of Authorized Representative) (Date)

978-735-7355
(Phone Number) (Fax Number)

jje@monmouthsolutions.com
(Email Address)



202-205-8800 | [sba.gov](https://www.sba.gov)
409 3rd St, SW. Washington DC 20416

March 14, 2023

MONMOUTH SOLUTIONS, INC
SAM UEI: E474YENAVPB7
93 BUTMAN RD
LOWELL, MA 01852

Dear MONMOUTH SOLUTIONS, INC:

I am writing to inform you that MONMOUTH SOLUTIONS, INC has been certified by the Veteran Small Business Certification Program (VetCert) at SBA. Your certification confirms your eligibility to compete for set-aside contracting opportunities, as well as other benefits, as a Service-Disabled Veteran-Owned Small Business (SDVOSB).

What you need to know:

- MONMOUTH SOLUTIONS, INC is certified as a Service-Disabled Veteran-Owned Small Business (SDVOSB) and publicly listed at veterans.certify.sba.gov.
- Your certification is valid for three (3) years from the date of this letter.
- You may visit [SBA's website to download SBA-approved digital icons](https://www.sba.gov) that indicate your certification status.
- SBA may conduct a program examination at your office or work site during your certification period to verify the accuracy of your certification.
- You may apply for recertification 120 days prior to your expiration date by logging in to your Veteran Small Business Certification profile.

What to do if your business changes:

You must inform SBA of any changes to the business that could affect its eligibility for the program, such as:

- a closure
- a change to the firm's ownership, business structure, or control
- filing of a bankruptcy
- a change in a Veteran-owner's active duty status

You can inform SBA of changes through the VetCert website at veterans.certify.sba.gov. Failure to report eligibility changes within 30 days of the change could result in:

- Civil and criminal penalties
- A referral to the Debarment and Suspension Committee
- Decertification and removal from the Veteran Small Business Certification Program

Please keep a copy of this letter to confirm MONMOUTH SOLUTIONS, INC's continued program eligibility. Thank you for your service to our country and for continuing to serve the United States through small business ownership.

Sincerely,

John B. Perkins

John B. Perkins
Director Veteran Small Business Certification Program



All SBA programs and services are extended to the public on a nondiscriminatory basis.