



The following documentation is an electronically-submitted vendor response to an advertised solicitation from the *West Virginia Purchasing Bulletin* within the Vendor Self-Service portal at wvOASIS.gov. As part of the State of West Virginia's procurement process, and to maintain the transparency of the bid-opening process, this documentation submitted online is publicly posted by the West Virginia Purchasing Division at WVPurchasing.gov with any other vendor responses to this solicitation submitted to the Purchasing Division in hard copy format.

Header 1

List View

General Information | Contact | Default Values | Discount | Document Information | Clarification Request

Procurement Folder: 1038010

Procurement Type: Central Master Agreement

Vendor ID: 000000233055

Legal Name: SIGNALISATION VER MAC INC

Alias/DBA:

Total Bid: \$82,500.00

Response Date: 06/07/2022

Response Time: 16:36

Responded By User ID: vermer

First Name: Kimberly

Last Name: Jack

Email: kim.jack@ver-mac.com

Phone: 418-654-1303

SO Doc Code: CRFQ

SO Dept: 0803

SO Doc ID: DOT2200000172

Published Date: 6/2/22

Close Date: 6/8/22

Close Time: 13:30

Status: Closed

Solicitation Description: ADDENDUM NO_2 Trailer Mounted Solar Powered Arrow

Total of Header Attachments: 1

Total of All Attachments: 1



Department of Administration
 Purchasing Division
 2019 Washington Street East
 Post Office Box 50130
 Charleston, WV 25305-0130

State of West Virginia
Solicitation Response

Proc Folder: 1038010
Solicitation Description: ADDENDUM NO_2 Trailer Mounted Solar Powered Arrow Board
Proc Type: Central Master Agreement

Solicitation Closes	Solicitation Response	Version
2022-06-08 13:30	SR 0803 ESR06072200000007711	1

VENDOR 000000233055 SIGNALISATION VER MAC INC
--

Solicitation Number: CRFQ 0803 DOT2200000172
Total Bid: 82500 **Response Date:** 2022-06-07 **Response Time:** 16:36:15
Comments:

FOR INFORMATION CONTACT THE BUYER John W Estep 304-558-2566 john.w.estep@wv.gov

Vendor Signature X	FEIN#	DATE
---------------------------	--------------	-------------

All offers subject to all terms and conditions contained in this solicitation

Line	Comm Ln Desc	Qty	Unit Issue	Unit Price	Ln Total Or Contract Amount
1	Trailer Mounted Solar Powered Message Board	15.00000	EA	5500.000000	82500.00

Comm Code	Manufacturer	Specification	Model #
46161520			

Commodity Line Comments:

Extended Description:

Trailer Mounted Solar Powered Message Board



Department of Administration
 Purchasing Division
 2019 Washington Street East
 Post Office Box 50130
 Charleston, WV 25305-0130

State of West Virginia
 Centralized Request for Quote
 Equipment

Proc Folder: 1038010			Reason for Modification: ADDENDUM NO_2 Attach Pre-Bid Sign-in Sheets
Doc Description: ADDENDUM NO_2 Trailer Mounted Solar Powered Arrow Board			
Proc Type: Central Master Agreement			
Date Issued	Solicitation Closes	Solicitation No	Version
2022-06-02	2022-06-08 13:30	CRFQ 0803 DOT2200000172	3

BID RECEIVING LOCATION

BID CLERK
 DEPARTMENT OF ADMINISTRATION
 PURCHASING DIVISION
 2019 WASHINGTON ST E
 CHARLESTON WV 25305
 US

VENDOR

Vendor Customer Code:

Vendor Name : Ver-Mac Inc.

Address : 3479

Street : Pollok Drive

City : Conroe

State : TX **Country :** USA **Zip :** 77303

Principal Contact : Kimberly Jack

Vendor Contact Phone: 418-654-1303 **Extension:**

FOR INFORMATION CONTACT THE BUYER
 John W Estep
 304-558-2566
 john.w.estep@wv.gov

Vendor Signature X  **FEIN#** 98-1359787 **DATE** June 7th 2022

All offers subject to all terms and conditions contained in this solicitation

ADDITIONAL INFORMATION

ADDENDUM NO_2

Addendum No_2 issued to publish and distribute the attached information to the Vendor Community

REQUEST FOR QUOTATION:

The West Virginia Purchasing Division is soliciting bids on behalf of the West Virginia Division of Highways, Department of Transportation to establish an open-end contract for Trailer Mounted Solar Powered Arrow Board. Per the Bid Requirements, Specifications, Terms and Conditions attached to this Solicitation.

INVOICE TO**SHIP TO**

DIVISION OF HIGHWAYS
EQUIPMENT DIVISION RT 33
83 BRUSHY ROAD
CROSSING, PO BOX 610
BUCKHANNON WV
US

DIVISION OF HIGHWAYS
EQUIPMENT DIVISION
83 BRUSHY FORK RD
CROSSING
BUCKHANNON WV
US

Line	Comm Ln Desc	Qty	Unit Issue	Unit Price	Total Price
1	Trailer Mounted Solar Powered Message Board	15.00000	EA	\$5,500.00	\$82,500.00

Comm Code	Manufacturer	Specification	Model #
46161520	Ver-Mac	ST-4815	ST-4815

Extended Description:

Trailer Mounted Solar Powered Message Board

SCHEDULE OF EVENTS

Line	Event	Event Date
1	PREBID- Equipment Div. 10:30am Buckhannon WV	2022-05-26
2	Tech Questions due by 10:00am	2022-06-02

SOLICITATION NUMBER: CRFQ DOT2200000172

Addendum Number: 2

The purpose of this addendum is to modify the solicitation identified as CRFQ DOT22000000172 (“Solicitation”) to reflect the change(s) identified and described below.

Applicable Addendum Category:

- Modify bid opening date and time
- Modify specifications of product or service being sought
- Attachment of vendor questions and responses
- Attachment of pre-bid sign-in sheet
- Correction of error
- Other

Additional Documentation:

Pre-Bid Sign-In Sheets

Bid Opening remains 06/08/2022 at 1:30pm

Terms and Conditions:

1. All provisions of the Solicitation and other addenda not modified herein shall remain in full force and effect.
2. Vendor should acknowledge receipt of all addenda issued for this Solicitation by completing an Addendum Acknowledgment, a copy of which is included herewith. Failure to acknowledge addenda may result in bid disqualification. The addendum acknowledgement should be submitted with the bid to expedite document processing.

Pre-Bid Sign-In Sheet

Solicitation Number: CRFQ 0803 DOT2200000172
 Date of Pre-Bid Meeting: May 26, 2022 10:30 A.M.
 Location of Prebid Meeting: Buckhannon WV Equipment Division

Please Note:

Vendors must sign-in on this sheet to verify attendance at the Pre-Bid meeting.
 Failure to legibly sign in may be grounds for declaring a vendor ineligible to bid.
 For further verification, please also provide a business card if possible.

<u>Firm Represented:*</u>	<u>Rep Name (Printed):</u>	<u>Firm Address:</u>	<u>Telephone #:</u>	<u>Fax #:</u>	<u>Email:</u>
National Capital Ind.	Joe Senddaker	3420 Kenilworth Ave. Bladensburg MD 20710	301 343 2234	301 779 7644	Joe@natcap.com
Ver-mac	Tommy Lockwood	3479 Pollok Dr. Conroe, TX 77303	336-250 0494	(418) 654 0517	tommy.lockwood@ver-mac.com
Mid Atlantic Maintenance	Cameron Morrison	3164 Southern Hwy Mineral Wells WV 26150	304 964 4016	304 489 7214	cmorrison@midatlanticusa.com
American Signal Company	Seth Johnson	2755 Bankers Industrial Dr. Atlanta, GA 30360	404-978-5646	770-448-8970	sjohnson@amsis.com
WUTRACKER COMPANY	GARY GRAY	P.O. BOX 473 CHARLESTON WV 25322	304-346-5301	304-346-5365	wutrackerc@msn.com

***One Vendor Per Representative - No one individual is permitted to represent more than one vendor at the pre-bid meeting. Any individual that does attempt to represent two or more vendors will be required to select one vendor to which the individual's attendance will be attributed. The vendors not selected will be deemed to have not attended the pre-bid meeting unless another individual attended on their behalf.**

Pre-Bid Sign-In Sheet

Solicitation Number: CRFQ 0803 DOT2200000172

Date of Pre-Bid Meeting: May 26, 2022 10:30 A.M.

Location of Prebid Meeting: Buckhannon WV Equipment Division

Please Note:

Vendors must sign-in on this sheet to verify attendance at the Pre-Bid meeting.
 Failure to legibly sign in may grounds for declaring a vendor ineligible to bid.
 For further verification, please also provide a business card if possible.

Firm Represented:*	Rep Name (Printed):	Firm Address:	Telephone #:	Fax #:	Email:
WV DOH	Pam Hall	Buckhannon	304-471-0139		pamela.j.hall@wv.gov
WVDOH	JD Haller		304-471-0141		JD.S.Haller@wv.gov
WVDOH	Justin Godwin	Buckhannon	304-471-0139		justin.L.godwin@wv.gov

***One Vendor Per Representative** - No one individual is permitted to represent more than one vendor at the pre-bid meeting. Any individual that does attempt to represent two or more vendors will be required to select one vendor to which the individual's attendance will be attributed. The vendors not selected will be deemed to have not attended the pre-bid meeting unless another individual attended on their behalf.

OFFICE (304) 346-5301
(800) 640-8245



WEST VIRGINIA TRACTOR COMPANY

CONSTRUCTION, MINING, MUNICIPAL & INDUSTRIAL EQUIPMENT

www.wvtractor.com

GARY W. GRADY
PRESIDENT
Cell (304) 549-6068

P. O. BOX 473
214 VIRGINIA ST. W.
CHAS., WV 25322/25302

wvtractor@msn.com

GSA GS-07F-0399L

Seth Johnson

Regional Sales Manager



AMERICAN SIGNAL COMPANY

Office: 770.448.6650 ext 112

Mobile: 404.978.5646

Fax: 770.448.8970

Email: sjohnson@amsig.com

2755 Bankers Industrial Dr. Atlanta GA 30360 | amsig.com



NATIONAL CAPITAL INDUSTRIES®

Joe Senddorfer

Sales Manager

Bids / Estimating

Construction Materials
Highway, Safety & ITS Products
General Tools & Supplies

O: 410.644.0300

C: 301.343.2234

jsenddorfer@natcap.com

TOMMY LOCKWOOD

SOUTHEAST REGIONAL SALES MANAGER

📍 291 BIRCHRIDGE DR., KERNERSVILLE, NC 27284

📞 336.250.0494

📞 1.888.488.7446

✉️ TOMMY.LOCKWOOD@VER-MAC.COM

🌐 WWW.VER-MAC.COM



ADDENDUM ACKNOWLEDGEMENT FORM
SOLICITATION NO.: CRFQ DOT2200000172

Instructions: Please acknowledge receipt of all addenda issued with this solicitation by completing this addendum acknowledgment form. Check the box next to each addendum received and sign below. Failure to acknowledge addenda may result in bid disqualification.

Acknowledgment: I hereby acknowledge receipt of the following addenda and have made the necessary revisions to my proposal, plans and/or specification, etc.

Addendum Numbers Received:

(Check the box next to each addendum received)

- | | |
|--|--|
| <input type="checkbox"/> Addendum No. 1 | <input type="checkbox"/> Addendum No. 6 |
| <input checked="" type="checkbox"/> Addendum No. 2 | <input type="checkbox"/> Addendum No. 7 |
| <input type="checkbox"/> Addendum No. 3 | <input type="checkbox"/> Addendum No. 8 |
| <input type="checkbox"/> Addendum No. 4 | <input type="checkbox"/> Addendum No. 9 |
| <input type="checkbox"/> Addendum No. 5 | <input type="checkbox"/> Addendum No. 10 |

I understand that failure to confirm the receipt of addenda may be cause for rejection of this bid. I further understand that that any verbal representation made or assumed to be made during any oral discussion held between Vendor's representatives and any state personnel is not binding. Only the information issued in writing and added to the specifications by an official addendum is binding.

Ver-Mac Inc.

Company

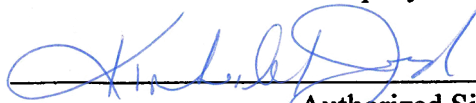

Authorized Signature

June 7th 2022

Date

NOTE: This addendum acknowledgment should be submitted with the bid to expedite document processing.



Department of Administration
 Purchasing Division
 2019 Washington Street East
 Post Office Box 50130
 Charleston, WV 25305-0130

State of West Virginia
 Centralized Request for Quote
 Equipment

Proc Folder: 1038010			Reason for Modification: ADDENDUM NO_1 Vendor Questions and Responses
Doc Description: ADDENDUM NO_1 Trailer Mounted Solar Powered Arrow Board			
Proc Type: Central Master Agreement			
Date Issued	Solicitation Closes	Solicitation No	Version
2022-05-17	2022-06-08 13:30	CRFQ 0803 DOT2200000172	2

BID RECEIVING LOCATION

BID CLERK
 DEPARTMENT OF ADMINISTRATION
 PURCHASING DIVISION
 2019 WASHINGTON ST E
 CHARLESTON WV 25305
 US

VENDOR

Vendor Customer Code:
Vendor Name : Ver-Mac Inc.
Address : 3479
Street : Pollok Drive
City : Conroe
State : TX **Country :** USA **Zip :** 77303
Principal Contact : Kimberly Jack
Vendor Contact Phone: 418-654-1303 **Extension:**

FOR INFORMATION CONTACT THE BUYER

John W Estep
 304-558-2566
 john.w.estep@wv.gov

Vendor Signature X  **FEIN#** 98-1359787 **DATE** June 7th 2022

All offers subject to all terms and conditions contained in this solicitation

ADDITIONAL INFORMATION

ADDENDUM NO_1

Addendum No_1 issued to publish and distribute the attached information to the Vendor Community

REQUEST FOR QUOTATION:

The West Virginia Purchasing Division is soliciting bids on behalf of the West Virginia Division of Highways, Department of Transportation to establish an open-end contract for Trailer Mounted Solar Powered Arrow Board. Per the Bid Requirements, Specifications, Terms and Conditions attached to this Solicitation.

INVOICE TO**SHIP TO**

DIVISION OF HIGHWAYS
EQUIPMENT DIVISION RT 33
83 BRUSHY ROAD
CROSSING, PO BOX 610
BUCKHANNON WV
US

DIVISION OF HIGHWAYS
EQUIPMENT DIVISION
83 BRUSHY FORK RD
CROSSING
BUCKHANNON WV
US

Line	Comm Ln Desc	Qty	Unit Issue	Unit Price	Total Price
1	Trailer Mounted Solar Powered Message Board	15.00000	EA	\$5,500.00	\$82,500.00

Comm Code	Manufacturer	Specification	Model #
46161520	Ver-Mac	ST-4815	ST-4815

Extended Description:

Trailer Mounted Solar Powered Message Board

SCHEDULE OF EVENTS

Line	Event	Event Date
1	PREBID- Equipment Div. 10:30am Buckhannon WV	2022-05-26
2	Tech Questions due by 10:00am	2022-06-02

SOLICITATION NUMBER: CRFQ DOT2200000172

Addendum Number: 1

The purpose of this addendum is to modify the solicitation identified as CRFQ DOT22000000172 (“Solicitation”) to reflect the change(s) identified and described below.

Applicable Addendum Category:

- Modify bid opening date and time
- Modify specifications of product or service being sought
- Attachment of vendor questions and responses
- Attachment of pre-bid sign-in sheet
- Correction of error
- Other

Additional Documentation:

Vendor Questions and Responses

Bid Opening remains 06/08/2022 at 1:30pm

Terms and Conditions:

1. All provisions of the Solicitation and other addenda not modified herein shall remain in full force and effect.
2. Vendor should acknowledge receipt of all addenda issued for this Solicitation by completing an Addendum Acknowledgment, a copy of which is included herewith. Failure to acknowledge addenda may result in bid disqualification. The addendum acknowledgement should be submitted with the bid to expedite document processing.

ADDENDUM FOR PRE-BID

CRFQ 0803 DOT2200000172

TRAILER MOUNTED SOLAR POWERED ARROW BOARD

The original language in contract will be listed first with question and answer to follow below.

1. 3.2.1.1 The vendor is responsible to furnish a full matrix trailer mounted solar powered message board light that is properly engineered and that confirms to all and any laws governing such equipment.

Answer: Yes, we will change this to read: The vendor is responsible to furnish a trailer mounted solar powered arrow board light that is properly engineered and that confirms to all and any laws governing such equipment.

2. 3.2.4 Training:

3.2.4.1 Manufacturers and/or dealers will be required to stage a thorough seminar on the subjects of Preventative Maintenance, Operator, and Mechanic Training. In order to keep operators and mechanics updated, the successful vendor shall conduct training sessions covering the operation, maintenance, trouble-shooting with each purchase order against this open end contract.

Manufacturers and/or dealers shall be required to furnish the Training Academy with one (1) Operator's Manual to be shipped direct to:

WVDOH
Training Academy
P.O. Box 610
Buckhannon, West Virginia 26201

Prior to delivery of the pilot unit. Training seminar to be held at the WVDOT, Equipment Division, Buckhannon, WV.

Question: Should Bidder Understand:

A. That there will be multiple PO's?

Answer: Yes there is a possibility of multiple PO's

B. That each PO will have its own delivery address? Multiple delivery sites will greatly complicate the delivery process and will add significant expense, if vendors must assume that there may be as many delivery addresses as units

Answer: All Deliveries will be to the WVDOH Equipment Division, 83 Brushy Fork Road Crossing, Buckhannon, WV.

C. That training will be required at all district shops that issue their own PO's? Multiple training sites will add significant expense, if vendors are forced assume that there may be as many delivery address as units.

Answer: All training is always done at the WVDOH Equipment Division, 83 Brushy Fork Road Crossing, Buckhannon, WV.

ADDENDUM ACKNOWLEDGEMENT FORM
SOLICITATION NO.: CRFQ DOT2200000172

Instructions: Please acknowledge receipt of all addenda issued with this solicitation by completing this addendum acknowledgment form. Check the box next to each addendum received and sign below. Failure to acknowledge addenda may result in bid disqualification.

Acknowledgment: I hereby acknowledge receipt of the following addenda and have made the necessary revisions to my proposal, plans and/or specification, etc.

Addendum Numbers Received:

(Check the box next to each addendum received)

- | | |
|--|--|
| <input checked="" type="checkbox"/> Addendum No. 1 | <input type="checkbox"/> Addendum No. 6 |
| <input type="checkbox"/> Addendum No. 2 | <input type="checkbox"/> Addendum No. 7 |
| <input type="checkbox"/> Addendum No. 3 | <input type="checkbox"/> Addendum No. 8 |
| <input type="checkbox"/> Addendum No. 4 | <input type="checkbox"/> Addendum No. 9 |
| <input type="checkbox"/> Addendum No. 5 | <input type="checkbox"/> Addendum No. 10 |

I understand that failure to confirm the receipt of addenda may be cause for rejection of this bid. I further understand that that any verbal representation made or assumed to be made during any oral discussion held between Vendor's representatives and any state personnel is not binding. Only the information issued in writing and added to the specifications by an official addendum is binding.

Ver-Mac Inc.

Company



Authorized Signature

June 7th 2022

Date

NOTE: This addendum acknowledgment should be submitted with the bid to expedite document processing.



Department of Administration
 Purchasing Division
 2019 Washington Street East
 Post Office Box 50130
 Charleston, WV 25305-0130

State of West Virginia
 Centralized Request for Quote
 Equipment

Proc Folder: 1038010			Reason for Modification:
Doc Description: Trailer Mounted Solar Powered Arrow Board			
Proc Type: Central Master Agreement			
Date Issued	Solicitation Closes	Solicitation No	Version
2022-05-16	2022-06-08 13:30	CRFQ 0803 DOT2200000172	1

BID RECEIVING LOCATION

BID CLERK
 DEPARTMENT OF ADMINISTRATION
 PURCHASING DIVISION
 2019 WASHINGTON ST E
 CHARLESTON WV 25305
 US

VENDOR

Vendor Customer Code:

Vendor Name : Ver-Mac Inc.

Address : 3479

Street : Pollok Drive

City : Conroe

State : TX **Country :** USA **Zip :** 77303

Principal Contact : Kimberly Jack

Vendor Contact Phone: 418-654-1303 **Extension:**

FOR INFORMATION CONTACT THE BUYER

John W Estep
 304-558-2566
 john.w.estep@wv.gov

Vendor Signature X

FEIN# 98-1359787

DATE June 7th 2022

All offers subject to all terms and conditions contained in this solicitation

ADDITIONAL INFORMATION**REQUEST FOR QUOTATION:**

The West Virginia Purchasing Division is soliciting bids on behalf of the West Virginia Division of Highways, Department of Transportation to establish an open-end contract for Trailer Mounted Solar Powered Arrow Board. Per the Bid Requirements, Specifications, Terms and Conditions attached to this Solicitation.

INVOICE TO		SHIP TO	
DIVISION OF HIGHWAYS EQUIPMENT DIVISION RT 33 83 BRUSHY ROAD CROSSING, PO BOX 610 BUCKHANNON WV US		DIVISION OF HIGHWAYS EQUIPMENT DIVISION 83 BRUSHY FORK RD CROSSING BUCKHANNON WV US	

Line	Comm Ln Desc	Qty	Unit Issue	Unit Price	Total Price
1	Trailer Mounted Solar Powered Message Board	15.00000	EA	\$5,500.00	\$82,500.00

Comm Code	Manufacturer	Specification	Model #
46161520	Ver-Mac	ST-4815	ST-4815

Extended Description:

Trailer Mounted Solar Powered Message Board

SCHEDULE OF EVENTS

Line	Event	Event Date
1	PREBID- Equipment Div. 10:30am Buckhannon WV	2022-05-26
2	Tech Questions due by 10:00am	2022-06-02

	Document Phase	Document Description	Page
DOT2200000172	Final	Trailer Mounted Solar Powered Arrow Board	3

ADDITIONAL TERMS AND CONDITIONS

See attached document(s) for additional Terms and Conditions

Exhibit A

Trailer Mounted Solar Powered Arrow Board

Item No.	Description:	Make/Model & Year	Estimated Unit Quantity	Unit Price	Item Total Cost
1	Trailer Mounted Solar Powered Arrow Board	Ver-mac / ST-4815 / 2022	15	\$5 500,00	\$82 500,00
Total Bid Cost					\$82 500,00

Vendor Information

Vendor Information: Ver-Mac Inc.

Contract Manager: Kimberly Jack

Address: 3479 Pollok Drive, Conroe TX 77303

Phone: 418-654-1303

Fax: 418-654-0517

Email: kim.jack@ver-mac.com

Signature:

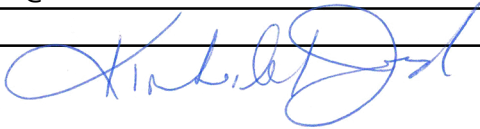

INSTRUCTIONS TO VENDORS SUBMITTING BIDS

1. REVIEW DOCUMENTS THOROUGHLY: The attached documents contain a solicitation for bids. Please read these instructions and all documents attached in their entirety. These instructions provide critical information about requirements that if overlooked could lead to disqualification of a Vendor's bid. All bids must be submitted in accordance with the provisions contained in these instructions and the Solicitation. Failure to do so may result in disqualification of Vendor's bid.

2. MANDATORY TERMS: The Solicitation may contain mandatory provisions identified by the use of the words "must," "will," and "shall." Failure to comply with a mandatory term in the Solicitation will result in bid disqualification.

3. PREBID MEETING: The item identified below shall apply to this Solicitation.

A pre-bid meeting will not be held prior to bid opening

A **MANDATORY PRE-BID** meeting will be held at the following place and time:

WV DOH Equipment Division
83 Brushy Fork Rd. Crossing
Buckhannon, WV 26201
May 26, 2022 @ 10:30am

All Vendors submitting a bid must attend the mandatory pre-bid meeting. Failure to attend the mandatory pre-bid meeting shall result in disqualification of the Vendor's bid. No one individual is permitted to represent more than one vendor at the pre-bid meeting. Any individual that does attempt to represent two or more vendors will be required to select one vendor to which the individual's attendance will be attributed. The vendors not selected will be deemed to have not attended the pre-bid meeting unless another individual attended on their behalf.

An attendance sheet provided at the pre-bid meeting shall serve as the official document verifying attendance. Any person attending the pre-bid meeting on behalf of a Vendor must list on the attendance sheet his or her name and the name of the Vendor he or she is representing.

Additionally, the person attending the pre-bid meeting should include the Vendor's E-Mail address, phone number, and Fax number on the attendance sheet. It is the Vendor's responsibility to locate the attendance sheet and provide the required information. Failure to complete the attendance sheet as required may result in disqualification of Vendor's bid.

All Vendors should arrive prior to the starting time for the pre-bid. Vendors who arrive after the starting time but prior to the end of the pre-bid will be permitted to sign in but are charged with knowing all matters discussed at the pre-bid.

Questions submitted at least five business days prior to a scheduled pre-bid will be discussed at the pre-bid meeting if possible. Any discussions or answers to questions at the pre-bid meeting are preliminary in nature and are non-binding. Official and binding answers to questions will be published in a written addendum to the Solicitation prior to bid opening.

4. VENDOR QUESTION DEADLINE: Vendors may submit questions relating to this Solicitation to the Purchasing Division. Questions must be submitted in writing. All questions must be submitted on or before the date listed below and to the address listed below to be considered. A written response will be published in a Solicitation addendum if a response is possible and appropriate. Non-written discussions, conversations, or questions and answers regarding this Solicitation are preliminary in nature and are nonbinding.

Submitted emails should have the solicitation number in the subject line.

Question Submission Deadline: June 2, 2022 by 10:00am

Submit Questions to: John Estep
2019 Washington Street, East
Charleston, WV 25305
Fax: (304) 558-3970
Email: john.w.estep@wv.gov

5. VERBAL COMMUNICATION: Any verbal communication between the Vendor and any State personnel is not binding, including verbal communication at the mandatory pre-bid conference. Only information issued in writing and added to the Solicitation by an official written addendum by the Purchasing Division is binding.

6. BID SUBMISSION: All bids must be submitted on or before the date and time of the bid opening listed in section 7 below. Vendors can submit bids electronically through wvOASIS, in paper form delivered to the Purchasing Division at the address listed below either in person or by courier, or in facsimile form by faxing to the Purchasing Division at the number listed below. Notwithstanding the foregoing, the Purchasing Division may prohibit the submission of bids electronically through wvOASIS at its sole discretion. Such a prohibition will be contained and communicated in the wvOASIS system resulting in the Vendor's inability to submit bids through wvOASIS. The Purchasing Division will not accept bids, modification of bids, or addendum acknowledgment forms via email. Bids submitted in paper or facsimile form must contain a signature. Bids submitted in wvOASIS are deemed to be electronically signed.

Any bid received by the Purchasing Division staff is considered to be in the possession of the Purchasing Division and will not be returned for any reason.

For Request for Proposal ("RFP") Responses Only: Submission of a response to a Request for Proposal is not permitted in wvOASIS. In the event that Vendor is responding to a request for proposal, the Vendor shall submit one original technical and one original cost proposal prior to the bid opening date and time identified in Section 7 below, plus _____ convenience copies of each to the Purchasing Division at the address shown below. Additionally, the Vendor should clearly identify and segregate the cost proposal from the technical proposal in a separately sealed envelope.

Bid Delivery Address and Fax Number:

Department of Administration, Purchasing Division
2019 Washington Street East
Charleston, WV 25305-0130
Fax: 304-558-3970

A bid submitted in paper or facsimile form should contain the information listed below on the face of the submission envelope or fax cover sheet. Otherwise, the bid may be rejected by the Purchasing Division.

VENDOR NAME:

BUYER: John Estep
SOLICITATION NO.: CRFQ 0803 DOT2200000172
BID OPENING DATE: June 8, 2022
BID OPENING TIME: 1:30pm
FAX NUMBER: 304-558-3970

7. BID OPENING: Bids submitted in response to this Solicitation will be opened at the location identified below on the date and time listed below. Delivery of a bid after the bid opening date and time will result in bid disqualification. For purposes of this Solicitation, a bid is considered delivered when confirmation of delivery is provided by wvOASIS (in the case of electronic submission) or when the bid is time stamped by the official Purchasing Division time clock (in the case of hand delivery).

Bid Opening Date and Time: June 8, 2022 @ 1:30pm

Bid Opening Location: Department of Administration, Purchasing Division
2019 Washington Street East
Charleston, WV 25305-0130

8. ADDENDUM ACKNOWLEDGEMENT: Changes or revisions to this Solicitation will be made by an official written addendum issued by the Purchasing Division. Vendor should acknowledge receipt of all addenda issued with this Solicitation by completing an Addendum Acknowledgment Form, a copy of which is included herewith. Failure to acknowledge addenda may result in bid disqualification. The addendum acknowledgement should be submitted with the bid to expedite document processing.

9. BID FORMATTING: Vendor should type or electronically enter the information onto its bid to prevent errors in the evaluation. Failure to type or electronically enter the information may result in bid disqualification.

10. ALTERNATE MODEL OR BRAND: Unless the box below is checked, any model, brand, or specification listed in this Solicitation establishes the acceptable level of quality only and is not intended to reflect a preference for, or in any way favor, a particular brand or vendor. Vendors may bid alternates to a listed model or brand provided that the alternate is at least equal to the model or brand and complies with the required specifications. The equality of any alternate being bid shall be determined by the State at its sole discretion. Any Vendor bidding an alternate model or brand should clearly identify the alternate items in its bid and should include manufacturer's

specifications, industry literature, and/or any other relevant documentation demonstrating the equality of the alternate items. Failure to provide information for alternate items may be grounds for rejection of a Vendor's bid.

This Solicitation is based upon a standardized commodity established under W. Va. Code § 5A-3-61. Vendors are expected to bid the standardized commodity identified. Failure to bid the standardized commodity will result in your firm's bid being rejected.

11. EXCEPTIONS AND CLARIFICATIONS: The Solicitation contains the specifications that shall form the basis of a contractual agreement. Vendor shall clearly mark any exceptions, clarifications, or other proposed modifications in its bid. Exceptions to, clarifications of, or modifications of a requirement or term and condition of the Solicitation may result in bid disqualification.

12. COMMUNICATION LIMITATIONS: In accordance with West Virginia Code of State Rules §148-1-6.6, communication with the State of West Virginia or any of its employees regarding this Solicitation during the solicitation, bid, evaluation or award periods, except through the Purchasing Division, is strictly prohibited without prior Purchasing Division approval. Purchasing Division approval for such communication is implied for all agency delegated and exempt purchases.

13. REGISTRATION: Prior to Contract award, the apparent successful Vendor must be properly registered with the West Virginia Purchasing Division and must have paid the \$125 fee, if applicable.

14. UNIT PRICE: Unit prices shall prevail in cases of a discrepancy in the Vendor's bid.

15. PREFERENCE: Vendor Preference may be requested in purchases of motor vehicles or construction and maintenance equipment and machinery used in highway and other infrastructure projects. Any request for preference must be submitted in writing with the bid, must specifically identify the preference requested with reference to the applicable subsection of West Virginia Code § 5A-3-37, and must include with the bid any information necessary to evaluate and confirm the applicability of the requested preference. A request form to help facilitate the request can be found at: www.state.wv.us/admin/purchase/vrc/Venpref.pdf.

15A. RECIPROCAL PREFERENCE: The State of West Virginia applies a reciprocal preference to all solicitations for commodities and printing in accordance with W. Va. Code § 5A-3-37(b). In effect, non-resident vendors receiving a preference in their home states, will see that same preference granted to West Virginia resident vendors bidding against them in West Virginia. Any request for reciprocal preference must include with the bid any information necessary to evaluate and confirm the applicability of the preference. A request form to help facilitate the request can be found at: www.state.wv.us/admin/purchase/vrc/Venpref.pdf.

16. SMALL, WOMEN-OWNED, OR MINORITY-OWNED BUSINESSES: For any solicitations publicly advertised for bid, in accordance with West Virginia Code §5A-3-37(a)(7) and W. Va. CSR § 148-22-9, any non-resident vendor certified as a small, women-owned, or minority-owned business under W. Va. CSR § 148-22-9 shall be provided the same preference made available to any resident vendor. Any non-resident small, women-owned, or

minority-owned business must identify itself as such in writing, must submit that writing to the Purchasing Division with its bid, and must be properly certified under W. Va. CSR § 148-22-9 prior to contract award to receive the preferences made available to resident vendors. Preference for a non-resident small, women-owned, or minority owned business shall be applied in accordance with W. Va. CSR § 148-22-9.

17. WAIVER OF MINOR IRREGULARITIES: The Director reserves the right to waive minor irregularities in bids or specifications in accordance with West Virginia Code of State Rules § 148-1-4.6.

18. ELECTRONIC FILE ACCESS RESTRICTIONS: Vendor must ensure that its submission in wvOASIS can be accessed and viewed by the Purchasing Division staff immediately upon bid opening. The Purchasing Division will consider any file that cannot be immediately accessed and viewed at the time of the bid opening (such as, encrypted files, password protected files, or incompatible files) to be blank or incomplete as context requires and are therefore unacceptable. A vendor will not be permitted to unencrypt files, remove password protections, or resubmit documents after bid opening to make a file viewable if those documents are required with the bid. A Vendor may be required to provide document passwords or remove access restrictions to allow the Purchasing Division to print or electronically save documents provided that those documents are viewable by the Purchasing Division prior to obtaining the password or removing the access restriction.

19. NON-RESPONSIBLE: The Purchasing Division Director reserves the right to reject the bid of any vendor as Non-Responsible in accordance with W. Va. Code of State Rules § 148-1-5.3, when the Director determines that the vendor submitting the bid does not have the capability to fully perform or lacks the integrity and reliability to assure good-faith performance.”

20. ACCEPTANCE/REJECTION: The State may accept or reject any bid in whole, or in part in accordance with W. Va. Code of State Rules § 148-1-4.5. and § 148-1-6.4.b.”

21. YOUR SUBMISSION IS A PUBLIC DOCUMENT: Vendor’s entire response to the Solicitation and the resulting Contract are public documents. As public documents, they will be disclosed to the public following the bid/proposal opening or award of the contract, as required by the competitive bidding laws of West Virginia Code §§ 5A-3-1 et seq., 5-22-1 et seq., and 5G-1-1 et seq. and the Freedom of Information Act West Virginia Code §§ 29B-1-1 et seq.

DO NOT SUBMIT MATERIAL YOU CONSIDER TO BE CONFIDENTIAL, A TRADE SECRET, OR OTHERWISE NOT SUBJECT TO PUBLIC DISCLOSURE.

Submission of any bid, proposal, or other document to the Purchasing Division constitutes your explicit consent to the subsequent public disclosure of the bid, proposal, or document. The Purchasing Division will disclose any document labeled “confidential,” “proprietary,” “trade secret,” “private,” or labeled with any other claim against public disclosure of the documents, to include any “trade secrets” as defined by West Virginia Code § 47-22-1 et seq. All submissions are subject to public disclosure without notice.

22. WITH THE BID REQUIREMENTS: In instances where these specifications require documentation or other information with the bid, and a vendor fails to provide it with the bid, the Director of the Purchasing Division reserves the right to request those items after bid opening and prior to contract award pursuant to the authority to waive minor irregularities in bids or specifications under W. Va. CSR § 148-1-4.6. This authority does not apply to instances where state law mandates receipt with the bid.

23. EMAIL NOTIFICATION OF AWARD: The Purchasing Division will attempt to provide bidders with e-mail notification of contract award when a solicitation that the bidder participated in has been awarded. For notification purposes, bidders must provide the Purchasing Division with a valid email address in the bid response. Bidders may also monitor *wvOASIS* or the Purchasing Division's website to determine when a contract has been awarded.

24. ISRAEL BOYCOTT CERTIFICATION: Vendor's act of submitting a bid in response to this solicitation shall be deemed a certification from bidder to the State that bidder is not currently engaged in, and will not for the duration of the contract, engage in a boycott of Israel. This certification is required by W. Va. Code § 5A-3-63.

REQUEST FOR QUOTATION
CLASS 839 TRAILER MOUNTED SOLAR POWERED ARROW BOARD

SPECIFICATIONS

1. **PURPOSE AND SCOPE:** The West Virginia Purchasing Division is soliciting bids On behalf of the West Virginia Division of Highways, Department of Transportation to establish an open-end contract for Trailer Mounted Solar Powered Arrow Board.

2. **DEFINITIONS:** The terms listed below shall have the meanings assigned to them below. Additional definitions can be found in section 2 of the General Terms and Conditions.
 - 2.1 **“Contract Item” or “Contract Items”** means the list of items identified in Section 3, Subsection 1 below.

 - 2.2 **“Pricing Pages”** means the schedule of prices, estimated order quantity, and totals contained in wvOASIS or attached hereto as Exhibit A, and used to evaluate the Solicitation responses.

 - 2.3 **“Solicitation”** means the official notice of an opportunity to supply the State with goods or services that is published by the Purchasing Division.

 - 2.4 **“WVDOH”** means West Virginia Division of Highways.

 - 2.5 **“OSHA”** means Occupational Safety and Health Act of 1970/ Exhibit C, Reference www.osha.gov.

 - 2.6 **“RF”** means Interference radio frequency.

 - 2.7 **“L.E.D.”** means lighting emitting diode.

3. **GENERAL REQUIREMENTS:**
 - 3.1 **Contract Items and Mandatory Requirements:** Vendor shall provide Agency with the Contract Items listed below on an open-end and continuing basis. Contract Items must meet or exceed the mandatory requirements as shown below.

REQUEST FOR QUOTATION
CLASS 839 TRAILER MOUNTED SOLAR POWERED ARROW BOARD

3.1.1 General – Trailer Mounted Solar Powered Arrow Board.

3.1.1.1 The unit specified herein and offered shall be manufactured after January 1, 2022 and must be a new unit, not previously used or sold.

3.1.2 Arrow Board

3.1.2.1 The arrow board shall be a weather-tight panel/minimum 48 inches high by 96 inches wide.

3.1.2.2 The height from the bottom of the panel to the roadway when deployed shall be seven (7) feet above the roadway.

3.1.3 Power Source

3.1.3.1 Arrow board shall have built in auxiliary battery charger which would enable the batteries to be hooked up to an AC power source at the storage yard or off of a generator in the field so that the batteries shall be fully charged.

3.1.3.2 Charge time and charger version shall be based on the manufacturer's battery configuration.

3.1.3.3 The battery bank shall be of sufficient size and capacity to power the unit a minimum of 30 days with no solar assist.

3.1.3.4 The solar generator shall incorporate a 12 Volt DC Photovoltaic Solar Panel mounted on a self-erecting, automatic positioning device located above the unit.

3.1.3.5 The batteries shall be protected to prevent damage due to overcharging or discharging too deeply at any temperature.

3.1.3.6 The unit shall go to four (4) corner caution when charging is required.

REQUEST FOR QUOTATION
CLASS 839 TRAILER MOUNTED SOLAR POWERED ARROW BOARD

3.1.4 Face Panel

- 3.1.4.1** Lamps shall be five (5) inch amber L.E.D. with minimum angularity of 30 degrees.
- 3.1.4.2** The unit shall increase lamp brightness when the ambient light level increases to five (5) foot candles, plus or minus one (1) foot candle and minimum legibility distance of one (1) mile.
- 3.1.4.3** The face of the panel shall be flat black with 15 hooded lamps.
- 3.1.4.4** The unit shall have the capability of the following modes of operation:
- (1) Right arrow – ten (10) lamps flashing in unison.
 - (2) Left arrow - ten (10) lamps flashing in unison.
 - (3) Double arrow – five (5) lamps in each arrowhead and three (3) lamps in shaft, all flashing in unison.
 - (4) Warning bar – seven (7) horizontal lamps flashing in unison.
 - (5) Four point caution – four (4) outermost corner lamps flashing in unison.
 - (6) Indicator lights on back of panel.
- 3.1.4.5** The flash rate shall be 30 flashes per minute and the flash cycle time shall be two (2) seconds with 50 percent on time.

3.1.5 Controller

- 3.1.5.1** The arrow board controller shall be housed in a weatherproof, lockable enclosure.

3.1.6 Communication

- 3.1.6.1** Unit shall be safe guarded from any unwanted outside RF interference which would include but not limited to VHF/FM receiver, 2-way receiver, cell phones, etc.

REQUEST FOR QUOTATION
CLASS 839 TRAILER MOUNTED SOLAR POWERED ARROW BOARD

3.1.7 Paint

3.1.7.1 Arrow board shall be painted flat black.

3.1.8 Trailer

3.1.8.1 2,000 lb. axle with leaf springs.

3.1.8.2 Tubeless, standard tread tires and wheels.

3.1.8.3 Heavy duty pintle eye hitch, 3" inner diameter.

3.1.8.4 Adjustable jack stand on trailer tongue.

3.1.8.5 The unit shall have five (5) telescoping jack stands, all four (4) corners and tongue to stabilize unit while in operation.

3.1.8.6 Lighting and safety chains for highway use.

3.1.8.7 Heavy duty lighting for towing of unit with quick disconnect male pin plug.

3.1.8.8 License plate brackets.

3.1.8.9 Wheel fenders.

3.1.8.10 The arrow board shall be raised and lowered using a hand operating winch (or hydraulic pump and ram).

3.1.8.11 Unit shall include LED tail lights, stop lights, turn signals, license mount with light, and all necessary reflectors.

3.1.9 Trailer Paint

3.1.9.1 The trailer shall be painted manufacturer standard color paint for this unit.

REQUEST FOR QUOTATION
CLASS 839 TRAILER MOUNTED SOLAR POWERED ARROW BOARD

3.1.10 Miscellaneous:

A. Unspecified Accessories & Features: All parts, equipment, accessories, material, design and performance characteristics not specified herein, but which are necessary to provide a complete unit, must be furnished with each unit and required to conform to strength, quality of material, and quality of workmanship to those which are advertised and provided to the market in general by the unit industry. All parts and accessories advertised and regularly supplied as standard shall be included, except those which would represent duplication of these specified and except those which, by specification, are not to be furnished. All standard safety features, required by Federal and State Law, shall be included.

B. Unit shall be delivered: to WVDOH with all manufacturers recommended safety related decals and safety features intact.

3.2.1 Vendor Responsibility:

3.2.1.1 The vendor is responsible to furnish a full matrix trailer mounted solar powered message board light that is properly engineered and that confirms to all and any laws governing such equipment.

3.2.2 Representative Unit for Test:

3.2.2.1 The successful vendor must (if specified) provide the DOH one (1) completed represented unit to be observed and evaluated on each order to in-sure compliance with specification. If requested, the time period for testing and evaluation shall be seven (7) working days following receipt of the unit. DOH will incur no obligation for deterioration of surfaces, finishes, seals, and mechanical or electrical parts on the unit resulting from operation and testing within the limits of these specifications; nor will DOH incur obligation for damage to the unit resulting from failure to meet specifications when due care and attention is given by DOH and testing is done within the limits of these specifications. Failure of the pilot unit to satisfactorily meet specifications as bid may be cause for cancellation of the purchase order and return of the delivered unit along with all associated equipment to the vendor at the vendor's expense.

REQUEST FOR QUOTATION
CLASS 839 TRAILER MOUNTED SOLAR POWERED ARROW BOARD

3.2.3 Operating and Service Manuals and Parts Lists:

3.2.3.1 An operator's manual must be included with each unit upon delivery. A "line sheet" (if applicable) and the "Equipment Preventative Maintenance Questionnaire", (Exhibit "B") must be with pilot unit upon delivery, Attn: JD Haller. There must be 12 service/shop/maintenance manuals and 14 parts manuals; USB storage drive is preferred in lieu of parts manuals. Manuals and USB storage drive shall be delivered upon completion of delivery of total units. Failure to do so will delay payment.

3.2.4 Training:

3.2.4.1 Manufacturers and/or dealers will be required to stage a thorough seminar on the subjects of Preventative Maintenance, Operator, and Mechanic Training. In order to keep operators and mechanics updated, the successful vendor shall conduct training sessions covering the operation, maintenance, troubleshooting with each purchase order against this open end contract.

Manufacturers and/or dealers shall be required to furnish the Training Academy with one (1) Operator's Manual to be shipped direct to:

WVDOH
Training Academy
P.O. Box 610
Buckhannon, West Virginia 26201

Prior to delivery of the pilot unit. Training seminar to be held at the WVDOT, Equipment Division, Buckhannon, WV.

3.2.5 Preventative Maintenance & Operator Procedures:

3.2.5.1 Manufacturers and/or dealers will be required to submit to the Equipment Division, in addition to the operating and service manuals, booklets and pamphlets explaining the Preventative Maintenance and Operator Procedures to be used by the operators of this equipment, and must include such things as daily prestart inspection procedure, service schedule, and routine maintenance required, safety precautions, etc.

REQUEST FOR QUOTATION
CLASS 839 TRAILER MOUNTED SOLAR POWERED ARROW BOARD

The successful vendor shall furnish all training aids; i.e. videos, projectors as required in conducting the training.

3.2.6 Warranty and Service Policy:

3.2.6.1 The unit must be accompanied upon delivery by the unit's manufacturers executed standard warranty and service policy.

4. CONTRACT AWARD:

4.1 Contract Award: The Contract is intended to provide Agencies with a purchase price on all Contract Items. The Contract shall be awarded to Vendor that provides the Contract Items meeting the required specifications for the lowest overall total cost as shown on the Pricing Pages.

4.2 Pricing Pages: Vendor should complete the Pricing Pages (Exhibit A) by completing the Year, Make, Model, and inserting quoted unit price. Vendor should take estimated Quantity and multiply by unit price to get grand total. Vendor should complete the pricing pages in their entirety as failure to do so may result in Vendor's bids being disqualified.

The Pricing Page contains a list of the Contract Items and estimated purchase volume. The estimated purchase volume for each item represents the approximate volume of anticipated purchases only. No future use of the Contract or any individual item is guaranteed or implied.

Vendor should electronically enter the information into the Pricing Pages through wvOASIS, if available, or as an electronic document. In most cases, the Vendor can request an electronic copy of the Pricing Pages for bid purposes by sending an email request to the following address:
John.W.Estep@wv.gov.

5. ORDERING AND PAYMENT:

5.1 Ordering: Vendor shall accept orders through wvOASIS, regular mail, facsimile, e-mail, or any other written forms of communication. Vendor may, but is not required

REQUEST FOR QUOTATION
CLASS 839 TRAILER MOUNTED SOLAR POWERED ARROW BOARD

to accept on-line orders through a secure internet ordering portal/website. If Vendor has the ability to accept on-line orders, it should include in its response a brief description of how Agencies may utilize the on-line ordering system. Vendor shall ensure that its on-line ordering system is properly secured prior to processing Agency orders on-line.

5.2 Payment: Vendor shall accept payment in accordance with the payment procedures of the State of West Virginia.

6. DELIVERY AND RETURN:

6.1 Delivery Time: Vendor shall deliver standard orders within 60 working days after orders are received. Vendor shall ship all orders in accordance with the above schedule and shall not hold orders until a minimum delivery quantity is met. A completed pilot model for inspection must be provided within 30 working day(s) after receipt of the purchase agreement by the successful vendor. Working day is defined as any week day, Monday thru Friday, excluding Federal and State Holidays. Vendor shall ship all orders in accordance with the above schedule and shall not hold orders until a minimum delivery quantity is met.

6.2 Late Delivery: The Agency placing the order under this Contract must be notified in writing if orders will be delayed for any reason. Any delay in delivery that could cause harm to an Agency will be grounds for cancellation of the delayed order, and/or obtaining the items ordered from a third party.

Any Agency seeking to obtain items from a third party under this provision must first obtain approval of the Purchasing Division.

6.3 Delivery Payment/Risk of Loss: Standard order delivery shall be F.O.B. Destination to the Agency's location. Vendor shall include the cost of standard order delivery charges in its bid pricing/discount and is not permitted to charge the Agency separately for such delivery. The Agency will pay delivery charges on all emergency orders provided that Vendor invoices those delivery costs as a separate charge with the original freight bill attached to the invoice.

6.4 Condition of Unit(s) Upon Delivery: All units must arrive at the prescribed delivery point having been completely pre-serviced with oil, lubricants, and coolant. All prescribed precautions pertaining to first operations and break-in of the unit are to be posted conspicuously on the unit for ready observance by the operator.

6.5 Delivery Point: Delivery point of the completed representative unit will be the WVDOH, Equipment Division, 83 Brushy Fork Road Crossing, Buckhannon, WV 26201.

REQUEST FOR QUOTATION
CLASS 839 TRAILER MOUNTED SOLAR POWERED ARROW BOARD

7. MISCELLANEOUS:

7.1 No Substitutions: Vendor shall supply only Contract Items submitted in Response to the Solicitation unless a contract modification is approved in accordance with the provisions contained in this Contract.

7.2 Contract Manager: During its performance of this Contract, Vendor must designate and maintain a primary contract manager responsible for overseeing Vendor's responsibilities under this Contract. The Contract manager must be available during normal business hours to address any customer service or other issues related to this Contract. Vendor should list its Contract manager and his or her contact information below.

Contract Manager: Kimberly Jack
Telephone Number: 418-654-1303
Fax Number: 418-654-0517
Email Address: kim.jack@ver-mac.com

8. VENDOR DEFAULT:

8.1 The following shall be considered a vendor default under this Contract.

8.1.1 Failure to provide Contract Items in accordance with the requirements contained herein.

8.1.2 Failure to comply with other specifications and requirements contained herein.

8.1.3 Failure to comply with any laws, rules, and ordinances applicable to the Contract Services provided under this Contract.

8.1.4 Failure to remedy deficient performance upon request.

8.2 The following remedy shall be available to Agency upon default.

8.2.1 Immediate cancellation of the contract.

REQUEST FOR QUOTATION
CLASS 839 TRAILER MOUNTED SOLAR POWERED ARROW BOARD

8.2.2 Immediate cancellation of one or more release orders issued under this Contract.

8.2.3 Any other remedies available in law or equity.

GENERAL TERMS AND CONDITIONS:

1. CONTRACTUAL AGREEMENT: Issuance of an Award Document signed by the Purchasing Division Director, or his designee, and approved as to form by the Attorney General's office constitutes acceptance by the State of this Contract made by and between the State of West Virginia and the Vendor. Vendor's signature on its bid, or on the Contract if the Contract is not the result of a bid solicitation, signifies Vendor's agreement to be bound by and accept the terms and conditions contained in this Contract.

2. DEFINITIONS: As used in this Solicitation/Contract, the following terms shall have the meanings attributed to them below. Additional definitions may be found in the specifications included with this Solicitation/Contract.

2.1. "Agency" or "Agencies" means the agency, board, commission, or other entity of the State of West Virginia that is identified on the first page of the Solicitation or any other public entity seeking to procure goods or services under this Contract.

2.2. "Bid" or "Proposal" means the vendors submitted response to this solicitation.

2.3. "Contract" means the binding agreement that is entered into between the State and the Vendor to provide the goods or services requested in the Solicitation.

2.4. "Director" means the Director of the West Virginia Department of Administration, Purchasing Division.

2.5. "Purchasing Division" means the West Virginia Department of Administration, Purchasing Division.

2.6. "Award Document" means the document signed by the Agency and the Purchasing Division, and approved as to form by the Attorney General, that identifies the Vendor as the contract holder.

2.7. "Solicitation" means the official notice of an opportunity to supply the State with goods or services that is published by the Purchasing Division.

2.8. "State" means the State of West Virginia and/or any of its agencies, commissions, boards, etc. as context requires.

2.9. "Vendor" or "Vendors" means any entity submitting a bid in response to the Solicitation, the entity that has been selected as the lowest responsible bidder, or the entity that has been awarded the Contract as context requires.

3. CONTRACT TERM; RENEWAL; EXTENSION: The term of this Contract shall be determined in accordance with the category that has been identified as applicable to this Contract below:

Term Contract

Initial Contract Term: The Initial Contract Term will be for a period of one (1) year. The Initial Contract Term becomes effective on the effective start date listed on the first page of this Contract and the Initial Contract Term ends on the effective end date also shown on the first page of this Contract.

Renewal Term: This Contract may be renewed upon the mutual written consent of the Agency, and the Vendor, with approval of the Purchasing Division and the Attorney General's office (Attorney General approval is as to form only). Any request for renewal should be delivered to the Agency and then submitted to the Purchasing Division thirty (30) days prior to the expiration date of the initial contract term or appropriate renewal term. A Contract renewal shall be in accordance with the terms and conditions of the original contract. Unless otherwise specified below, renewal of this Contract is limited to three (3) successive one (1) year periods or multiple renewal periods of less than one year, provided that the multiple renewal periods do not exceed the total number of months available in all renewal years combined. Automatic renewal of this Contract is prohibited. Renewals must be approved by the Vendor, Agency, Purchasing Division and Attorney General's office (Attorney General approval is as to form only)

Alternate Renewal Term – This contract may be renewed for _____ successive _____ year periods or shorter periods provided that they do not exceed the total number of months contained in all available renewals. Automatic renewal of this Contract is prohibited. Renewals must be approved by the Vendor, Agency, Purchasing Division and Attorney General's office (Attorney General approval is as to form only)

Delivery Order Limitations: In the event that this contract permits delivery orders, a delivery order may only be issued during the time this Contract is in effect. Any delivery order issued within one year of the expiration of this Contract shall be effective for one year from the date the delivery order is issued. No delivery order may be extended beyond one year after this Contract has expired.

Fixed Period Contract: This Contract becomes effective upon Vendor's receipt of the notice to proceed and must be completed within _____ days.

Fixed Period Contract with Renewals: This Contract becomes effective upon Vendor's receipt of the notice to proceed and part of the Contract more fully described in the attached specifications must be completed within _____ days. Upon completion of the work covered by the preceding sentence, the vendor agrees that:

the contract will continue for _____ years;

the contract may be renewed for _____ successive _____ year periods or shorter periods provided that they do not exceed the total number of months contained in all available renewals. Automatic renewal of this Contract is prohibited.

Renewals must be approved by the Vendor, Agency, Purchasing Division and Attorney

General's Office (Attorney General approval is as to form only).

One-Time Purchase: The term of this Contract shall run from the issuance of the Award Document until all of the goods contracted for have been delivered, but in no event will this Contract extend for more than one fiscal year.

Other: Contract Term specified in _____

4. AUTHORITY TO PROCEED: Vendor is authorized to begin performance of this contract on the date of encumbrance listed on the front page of the Award Document unless either the box for "Fixed Period Contract" or "Fixed Period Contract with Renewals" has been checked in Section 3 above. If either "Fixed Period Contract" or "Fixed Period Contract with Renewals" has been checked, Vendor must not begin work until it receives a separate notice to proceed from the State. The notice to proceed will then be incorporated into the Contract via change order to memorialize the official date that work commenced.

5. QUANTITIES: The quantities required under this Contract shall be determined in accordance with the category that has been identified as applicable to this Contract below.

Open End Contract: Quantities listed in this Solicitation/Award Document are approximations only, based on estimates supplied by the Agency. It is understood and agreed that the Contract shall cover the quantities actually ordered for delivery during the term of the Contract, whether more or less than the quantities shown.

Service: The scope of the service to be provided will be more clearly defined in the specifications included herewith.

Combined Service and Goods: The scope of the service and deliverable goods to be provided will be more clearly defined in the specifications included herewith.

One-Time Purchase: This Contract is for the purchase of a set quantity of goods that are identified in the specifications included herewith. Once those items have been delivered, no additional goods may be procured under this Contract without an appropriate change order approved by the Vendor, Agency, Purchasing Division, and Attorney General's office.

6. EMERGENCY PURCHASES: The Purchasing Division Director may authorize the Agency to purchase goods or services in the open market that Vendor would otherwise provide under this Contract if those goods or services are for immediate or expedited delivery in an emergency. Emergencies shall include, but are not limited to, delays in transportation or an unanticipated increase in the volume of work. An emergency purchase in the open market, approved by the Purchasing Division Director, shall not constitute a breach of this Contract and shall not entitle the Vendor to any form of compensation or damages. This provision does not excuse the State from fulfilling its obligations under a One-Time Purchase contract.

7. REQUIRED DOCUMENTS: All of the items checked in this section must be provided to the Purchasing Division by the Vendor as specified:

BID BOND (Construction Only): Pursuant to the requirements contained in W. Va. Code § 5-22-1(c), All Vendors submitting a bid on a construction project shall furnish a valid bid bond in the amount of five percent (5%) of the total amount of the bid protecting the State of West Virginia. The bid bond must be submitted with the bid.

PERFORMANCE BOND: The apparent successful Vendor shall provide a performance bond in the amount of 100% of the contract. The performance bond must be received by the Purchasing Division prior to Contract award.

LABOR/MATERIAL PAYMENT BOND: The apparent successful Vendor shall provide a labor/material payment bond in the amount of 100% of the Contract value. The labor/material payment bond must be delivered to the Purchasing Division prior to Contract award.

In lieu of the Bid Bond, Performance Bond, and Labor/Material Payment Bond, the Vendor may provide certified checks, cashier's checks, or irrevocable letters of credit. Any certified check, cashier's check, or irrevocable letter of credit provided in lieu of a bond must be of the same amount and delivered on the same schedule as the bond it replaces. A letter of credit submitted in lieu of a performance and labor/material payment bond will only be allowed for projects under \$100,000. Personal or business checks are not acceptable. Notwithstanding the foregoing, West Virginia Code § 5-22-1 (d) mandates that a vendor provide a performance and labor/material payment bond for construction projects. Accordingly, substitutions for the performance and labor/material payment bonds for construction projects is not permitted.

MAINTENANCE BOND: The apparent successful Vendor shall provide a two (2) year maintenance bond covering the roofing system. The maintenance bond must be issued and delivered to the Purchasing Division prior to Contract award.

LICENSE(S) / CERTIFICATIONS / PERMITS: In addition to anything required under the Section of the General Terms and Conditions entitled Licensing, the apparent successful Vendor shall furnish proof of the following licenses, certifications, and/or permits upon request and in a form acceptable to the State. The request may be prior to or after contract award at the State's sole discretion.

The apparent successful Vendor shall also furnish proof of any additional licenses or certifications contained in the specifications regardless of whether or not that requirement is listed above.

Revised 04/01/2022

8. INSURANCE: The apparent successful Vendor shall furnish proof of the insurance identified by a checkmark below and must include the State as an additional insured on each policy prior to Contract award. The insurance coverages identified below must be maintained throughout the life of this contract. Thirty (30) days prior to the expiration of the insurance policies, Vendor shall provide the Agency with proof that the insurance mandated herein has been continued. Vendor must also provide Agency with immediate notice of any changes in its insurance policies, including but not limited to, policy cancelation, policy reduction, or change in insurers. The apparent successful Vendor shall also furnish proof of any additional insurance requirements contained in the specifications prior to Contract award regardless of whether that insurance requirement is listed in this section.

Vendor must maintain:

- Commercial General Liability Insurance** in at least an amount of: \$1,000,000.00 per occurrence.
- Automobile Liability Insurance** in at least an amount of: \$1,000,000.00 per occurrence.
- Professional/Malpractice/Errors and Omission Insurance** in at least an amount of: _____ per occurrence. Notwithstanding the forgoing, Vendor's are not required to list the State as an additional insured for this type of policy.
- Commercial Crime and Third Party Fidelity Insurance** in an amount of: _____ per occurrence.
- Cyber Liability Insurance** in an amount of: _____ per occurrence.
- Builders Risk Insurance** in an amount equal to 100% of the amount of the Contract.
- Pollution Insurance** in an amount of: _____ per occurrence.
- Aircraft Liability** in an amount of: _____ per occurrence.
- State of West Virginia must be listed as additional insured on Insurance Certificate. Certificate holder should read as follows:
 - State of WV
1900 Kanawha Blvd. E., Bldg.5
Charleston, WV 25305
 -
 -

Notwithstanding anything contained in this section to the contrary, the Director of the Purchasing Division reserves the right to waive the requirement that the State be named as an additional insured on one or more of the Vendor's insurance policies if the Director finds that doing so is in the State's best interest.

9. WORKERS' COMPENSATION INSURANCE: Vendor shall comply with laws relating to workers compensation, shall maintain workers' compensation insurance when required, and shall furnish proof of workers' compensation insurance upon request.

10. [Reserved]

11. LIQUIDATED DAMAGES: This clause shall in no way be considered exclusive and shall not limit the State or Agency's right to pursue any other available remedy. Vendor shall pay liquidated damages in the amount specified below or as described in the specifications:

_____ for _____.

Liquidated Damages Contained in the Specifications.

Liquidated Damages Are Not Included in this Contract.

12. ACCEPTANCE: Vendor's signature on its bid, or on the certification and signature page, constitutes an offer to the State that cannot be unilaterally withdrawn, signifies that the product or service proposed by vendor meets the mandatory requirements contained in the Solicitation for that product or service, unless otherwise indicated, and signifies acceptance of the terms and conditions contained in the Solicitation unless otherwise indicated.

13. PRICING: The pricing set forth herein is firm for the life of the Contract, unless specified elsewhere within this Solicitation/Contract by the State. A Vendor's inclusion of price adjustment provisions in its bid, without an express authorization from the State in the Solicitation to do so, may result in bid disqualification. Notwithstanding the foregoing, Vendor must extend any publicly advertised sale price to the State and invoice at the lower of the contract price or the publicly advertised sale price.

14. PAYMENT IN ARREARS: Payments for goods/services will be made in arrears only upon receipt of a proper invoice, detailing the goods/services provided or receipt of the goods/services, whichever is later. Notwithstanding the foregoing, payments for software maintenance, licenses, or subscriptions may be paid annually in advance.

15. PAYMENT METHODS: Vendor must accept payment by electronic funds transfer and P-Card. (The State of West Virginia's Purchasing Card program, administered under contract by a banking institution, processes payment for goods and services through state designated credit cards.)

16. TAXES: The Vendor shall pay any applicable sales, use, personal property or any other taxes arising out of this Contract and the transactions contemplated thereby. The State of West Virginia is exempt from federal and state taxes and will not pay or reimburse such taxes.

17. ADDITIONAL FEES: Vendor is not permitted to charge additional fees or assess additional charges that were not either expressly provided for in the solicitation published by the State of West Virginia, included in the Contract, or included in the unit price or lump sum bid amount that Vendor is required by the solicitation to provide. Including such fees or charges as notes to the solicitation may result in rejection of vendor's bid. Requesting such fees or charges be paid after the contract has been awarded may result in cancellation of the contract.

18. FUNDING: This Contract shall continue for the term stated herein, contingent upon funds being appropriated by the Legislature or otherwise being made available. In the event funds are not appropriated or otherwise made available, this Contract becomes void and of no effect beginning on July 1 of the fiscal year for which funding has not been appropriated or otherwise made available. If that occurs, the State may notify the Vendor that an alternative source of funding has been obtained and thereby avoid the automatic termination. Non-appropriation or non-funding shall not be considered an event of default.

19. CANCELLATION: The Purchasing Division Director reserves the right to cancel this Contract immediately upon written notice to the vendor if the materials or workmanship supplied do not conform to the specifications contained in the Contract. The Purchasing Division Director may also cancel any purchase or Contract upon 30 days written notice to the Vendor in accordance with West Virginia Code of State Rules § 148-1-5.2.b.

20. TIME: Time is of the essence regarding all matters of time and performance in this Contract.

21. APPLICABLE LAW: This Contract is governed by and interpreted under West Virginia law without giving effect to its choice of law principles. Any information provided in specification manuals, or any other source, verbal or written, which contradicts or violates the West Virginia Constitution, West Virginia Code, or West Virginia Code of State Rules is void and of no effect.

22. COMPLIANCE WITH LAWS: Vendor shall comply with all applicable federal, state, and local laws, regulations and ordinances. By submitting a bid, Vendor acknowledges that it has reviewed, understands, and will comply with all applicable laws, regulations, and ordinances.

SUBCONTRACTOR COMPLIANCE: Vendor shall notify all subcontractors providing commodities or services related to this Contract that as subcontractors, they too are required to comply with all applicable laws, regulations, and ordinances. Notification under this provision must occur prior to the performance of any work under the contract by the subcontractor.

23. ARBITRATION: Any references made to arbitration contained in this Contract, Vendor's bid, or in any American Institute of Architects documents pertaining to this Contract are hereby deleted, void, and of no effect.

24. MODIFICATIONS: This writing is the parties' final expression of intent. Notwithstanding anything contained in this Contract to the contrary no modification of this Contract shall be binding without mutual written consent of the Agency, and the Vendor, with approval of the Purchasing Division and the Attorney General's office (Attorney General approval is as to form only). Any change to existing contracts that adds work or changes contract cost, and were not included in the original contract, must be approved by the Purchasing Division and the Attorney General's Office (as to form) prior to the implementation of the change or commencement of work affected by the change.

25. WAIVER: The failure of either party to insist upon a strict performance of any of the terms or provision of this Contract, or to exercise any option, right, or remedy herein contained, shall not be construed as a waiver or a relinquishment for the future of such term, provision, option, right, or remedy, but the same shall continue in full force and effect. Any waiver must be expressly stated in writing and signed by the waiving party.

26. SUBSEQUENT FORMS: The terms and conditions contained in this Contract shall supersede any and all subsequent terms and conditions which may appear on any form documents submitted by Vendor to the Agency or Purchasing Division such as price lists, order forms, invoices, sales agreements, or maintenance agreements, and includes internet websites or other electronic documents. Acceptance or use of Vendor's forms does not constitute acceptance of the terms and conditions contained thereon.

27. ASSIGNMENT: Neither this Contract nor any monies due, or to become due hereunder, may be assigned by the Vendor without the express written consent of the Agency, the Purchasing Division, the Attorney General's office (as to form only), and any other government agency or office that may be required to approve such assignments.

28. WARRANTY: The Vendor expressly warrants that the goods and/or services covered by this Contract will: (a) conform to the specifications, drawings, samples, or other description furnished or specified by the Agency; (b) be merchantable and fit for the purpose intended; and (c) be free from defect in material and workmanship.

29. STATE EMPLOYEES: State employees are not permitted to utilize this Contract for personal use and the Vendor is prohibited from permitting or facilitating the same.

30. PRIVACY, SECURITY, AND CONFIDENTIALITY: The Vendor agrees that it will not disclose to anyone, directly or indirectly, any such personally identifiable information or other confidential information gained from the Agency, unless the individual who is the subject of the information consents to the disclosure in writing or the disclosure is made pursuant to the Agency's policies, procedures, and rules. Vendor further agrees to comply with the Confidentiality Policies and Information Security Accountability Requirements, set forth in <http://www.state.wv.us/admin/purchase/privacy/default.html>.

31. YOUR SUBMISSION IS A PUBLIC DOCUMENT: Vendor's entire response to the Solicitation and the resulting Contract are public documents. As public documents, they will be disclosed to the public following the bid/proposal opening or award of the contract, as required by the competitive bidding laws of West Virginia Code §§ 5A-3-1 et seq., 5-22-1 et seq., and 5G-1-1 et seq. and the Freedom of Information Act West Virginia Code §§ 29B-1-1 et seq.

DO NOT SUBMIT MATERIAL YOU CONSIDER TO BE CONFIDENTIAL, A TRADE SECRET, OR OTHERWISE NOT SUBJECT TO PUBLIC DISCLOSURE.

Submission of any bid, proposal, or other document to the Purchasing Division constitutes your explicit consent to the subsequent public disclosure of the bid, proposal, or document. The Purchasing Division will disclose any document labeled "confidential," "proprietary," "trade secret," "private," or labeled with any other claim against public disclosure of the documents, to include any "trade secrets" as defined by West Virginia Code § 47-22-1 et seq. All submissions are subject to public disclosure without notice.

32. LICENSING: In accordance with West Virginia Code of State Rules § 148-1-6.1.e, Vendor must be licensed and in good standing in accordance with any and all state and local laws and requirements by any state or local agency of West Virginia, including, but not limited to, the West Virginia Secretary of State's Office, the West Virginia Tax Department, West Virginia Insurance Commission, or any other state agency or political subdivision. Obligations related to political subdivisions may include, but are not limited to, business licensing, business and occupation taxes, inspection compliance, permitting, etc. Upon request, the Vendor must provide all necessary releases to obtain information to enable the Purchasing Division Director or the Agency to verify that the Vendor is licensed and in good standing with the above entities.

SUBCONTRACTOR COMPLIANCE: Vendor shall notify all subcontractors providing commodities or services related to this Contract that as subcontractors, they too are required to be licensed, in good standing, and up-to-date on all state and local obligations as described in this section. Obligations related to political subdivisions may include, but are not limited to, business licensing, business and occupation taxes, inspection compliance, permitting, etc. Notification under this provision must occur prior to the performance of any work under the contract by the subcontractor.

33. ANTITRUST: In submitting a bid to, signing a contract with, or accepting a Award Document from any agency of the State of West Virginia, the Vendor agrees to convey, sell, assign, or transfer to the State of West Virginia all rights, title, and interest in and to all causes of action it may now or hereafter acquire under the antitrust laws of the United States and the State of West Virginia for price fixing and/or unreasonable restraints of trade relating to the particular commodities or services purchased or acquired by the State of West Virginia. Such assignment shall be made and become effective at the time the purchasing agency tenders the initial payment to Vendor.

34. VENDOR CERTIFICATIONS: By signing its bid or entering into this Contract, Vendor certifies (1) that its bid or offer was made without prior understanding, agreement, or connection with any corporation, firm, limited liability company, partnership, person or entity submitting a bid or offer for the same material, supplies, equipment or services; (2) that its bid or offer is in all respects fair and without collusion or fraud; (3) that this Contract is accepted or entered into without any prior understanding, agreement, or connection to any other entity that could be considered a violation of law; and (4) that it has reviewed this Solicitation in its entirety; understands the requirements, terms and conditions, and other information contained herein.

Vendor's signature on its bid or offer also affirms that neither it nor its representatives have any interest, nor shall acquire any interest, direct or indirect, which would compromise the performance of its services hereunder. Any such interests shall be promptly presented in detail to the Agency. The individual signing this bid or offer on behalf of Vendor certifies that he or she is authorized by the Vendor to execute this bid or offer or any documents related thereto on Vendor's behalf; that he or she is authorized to bind the Vendor in a contractual relationship; and that, to the best of his or her knowledge, the Vendor has properly registered with any State agency that may require registration.

35. VENDOR RELATIONSHIP: The relationship of the Vendor to the State shall be that of an independent contractor and no principal-agent relationship or employer-employee relationship is contemplated or created by this Contract. The Vendor as an independent contractor is solely liable for the acts and omissions of its employees and agents. Vendor shall be responsible for selecting, supervising, and compensating any and all individuals employed pursuant to the terms of this Solicitation and resulting contract. Neither the Vendor, nor any employees or subcontractors of the Vendor, shall be deemed to be employees of the State for any purpose whatsoever. Vendor shall be exclusively responsible for payment of employees and contractors for all wages and salaries, taxes, withholding payments, penalties, fees, fringe benefits, professional liability insurance premiums, contributions to insurance and pension, or other deferred compensation plans, including but not limited to, Workers' Compensation and Social Security obligations, licensing fees, etc. and the filing of all necessary documents, forms, and returns pertinent to all of the foregoing.

Vendor shall hold harmless the State, and shall provide the State and Agency with a defense against any and all claims including, but not limited to, the foregoing payments, withholdings, contributions, taxes, Social Security taxes, and employer income tax returns.

36. INDEMNIFICATION: The Vendor agrees to indemnify, defend, and hold harmless the State and the Agency, their officers, and employees from and against: (1) Any claims or losses for services rendered by any subcontractor, person, or firm performing or supplying services, materials, or supplies in connection with the performance of the Contract; (2) Any claims or losses resulting to any person or entity injured or damaged by the Vendor, its officers, employees, or subcontractors by the publication, translation, reproduction, delivery, performance, use, or disposition of any data used under the Contract in a manner not authorized by the Contract, or by Federal or State statutes or regulations; and (3) Any failure of the Vendor, its officers, employees, or subcontractors to observe State and Federal laws including, but not limited to, labor and wage and hour laws.

37. NO DEBT CERTIFICATION: In accordance with West Virginia Code §§ 5A-3-10a and 5-22-1(i), the State is prohibited from awarding a contract to any bidder that owes a debt to the State or a political subdivision of the State. By submitting a bid, or entering into a contract with the State, Vendor is affirming that (1) for construction contracts, the Vendor is not in default on any monetary obligation owed to the state or a political subdivision of the state, and (2) for all other contracts, neither the Vendor nor any related party owe a debt as defined above, and neither the Vendor nor any related party are in employer default as defined in the statute cited above unless the debt or employer default is permitted under the statute.

38. CONFLICT OF INTEREST: Vendor, its officers or members or employees, shall not presently have or acquire an interest, direct or indirect, which would conflict with or compromise the performance of its obligations hereunder. Vendor shall periodically inquire of its officers, members and employees to ensure that a conflict of interest does not arise. Any conflict of interest discovered shall be promptly presented in detail to the Agency.

39. REPORTS: Vendor shall provide the Agency and/or the Purchasing Division with the following reports identified by a checked box below:

Such reports as the Agency and/or the Purchasing Division may request. Requested reports may include, but are not limited to, quantities purchased, agencies utilizing the contract, total contract expenditures by agency, etc.

Quarterly reports detailing the total quantity of purchases in units and dollars, along with a listing of purchases by agency. Quarterly reports should be delivered to the Purchasing Division via email at purchasing.division@wv.gov.

40. BACKGROUND CHECK: In accordance with W. Va. Code § 15-2D-3, the State reserves the right to prohibit a service provider's employees from accessing sensitive or critical information or to be present at the Capitol complex based upon results addressed from a criminal background check. Service providers should contact the West Virginia Division of Protective Services by phone at (304) 558-9911 for more information.

41. PREFERENCE FOR USE OF DOMESTIC STEEL PRODUCTS: Except when authorized by the Director of the Purchasing Division pursuant to W. Va. Code § 5A-3-56, no contractor may use or supply steel products for a State Contract Project other than those steel products made in the United States. A contractor who uses steel products in violation of this section may be subject to civil penalties pursuant to W. Va. Code § 5A-3-56. As used in this section:

- a. "State Contract Project" means any erection or construction of, or any addition to, alteration of or other improvement to any building or structure, including, but not limited to, roads or highways, or the installation of any heating or cooling or ventilating plants or other equipment, or the supply of and materials for such projects, pursuant to a contract with the State of West Virginia for which bids were solicited on or after June 6, 2001.
- b. "Steel Products" means products rolled, formed, shaped, drawn, extruded, forged, cast, fabricated or otherwise similarly processed, or processed by a combination of two or more or such operations, from steel made by the open heath, basic oxygen, electric furnace, Bessemer or other steel making process.

- c. The Purchasing Division Director may, in writing, authorize the use of foreign steel products if:
 1. The cost for each contract item used does not exceed one tenth of one percent (.1%) of the total contract cost or two thousand five hundred dollars (\$2,500.00), whichever is greater. For the purposes of this section, the cost is the value of the steel product as delivered to the project; or
 2. The Director of the Purchasing Division determines that specified steel materials are not produced in the United States in sufficient quantity or otherwise are not reasonably available to meet contract requirements.

42. PREFERENCE FOR USE OF DOMESTIC ALUMINUM, GLASS, AND STEEL: In Accordance with W. Va. Code § 5-19-1 et seq., and W. Va. CSR § 148-10-1 et seq., for every contract or subcontract, subject to the limitations contained herein, for the construction, reconstruction, alteration, repair, improvement or maintenance of public works or for the purchase of any item of machinery or equipment to be used at sites of public works, only domestic aluminum, glass or steel products shall be supplied unless the spending officer determines, in writing, after the receipt of offers or bids, (1) that the cost of domestic aluminum, glass or steel products is unreasonable or inconsistent with the public interest of the State of West Virginia, (2) that domestic aluminum, glass or steel products are not produced in sufficient quantities to meet the contract requirements, or (3) the available domestic aluminum, glass, or steel do not meet the contract specifications. This provision only applies to public works contracts awarded in an amount more than fifty thousand dollars (\$50,000) or public works contracts that require more than ten thousand pounds of steel products.

The cost of domestic aluminum, glass, or steel products may be unreasonable if the cost is more than twenty percent (20%) of the bid or offered price for foreign made aluminum, glass, or steel products. If the domestic aluminum, glass or steel products to be supplied or produced in a “substantial labor surplus area”, as defined by the United States Department of Labor, the cost of domestic aluminum, glass, or steel products may be unreasonable if the cost is more than thirty percent (30%) of the bid or offered price for foreign made aluminum, glass, or steel products. This preference shall be applied to an item of machinery or equipment, as indicated above, when the item is a single unit of equipment or machinery manufactured primarily of aluminum, glass or steel, is part of a public works contract and has the sole purpose or of being a permanent part of a single public works project. This provision does not apply to equipment or machinery purchased by a spending unit for use by that spending unit and not as part of a single public works project.

All bids and offers including domestic aluminum, glass or steel products that exceed bid or offer prices including foreign aluminum, glass or steel products after application of the preferences provided in this provision may be reduced to a price equal to or lower than the lowest bid or offer price for foreign aluminum, glass or steel products plus the applicable preference. If the reduced bid or offer prices are made in writing and supersede the prior bid or offer prices, all bids or offers, including the reduced bid or offer prices, will be reevaluated in accordance with this rule.

43. INTERESTED PARTY SUPPLEMENTAL DISCLOSURE: W. Va. Code § 6D-1-2 requires that for contracts with an actual or estimated value of at least \$1 million, the Vendor must submit to the Agency a disclosure of interested parties prior to beginning work under this Contract. Additionally, the Vendor must submit a supplemental disclosure of interested parties reflecting any new or differing interested parties to the contract, which were not included in the original pre-work interested party disclosure, within 30 days following the completion or termination of the contract. A copy of that form is included with this solicitation or can be obtained from the WV Ethics Commission. This requirement does not apply to publicly traded companies listed on a national or international stock exchange. A more detailed definition of interested parties can be obtained from the form referenced above.

44. PROHIBITION AGAINST USED OR REFURBISHED: Unless expressly permitted in the solicitation published by the State, Vendor must provide new, unused commodities, and is prohibited from supplying used or refurbished commodities, in fulfilling its responsibilities under this Contract.

45. VOID CONTRACT CLAUSES – This Contract is subject to the provisions of West Virginia Code § 5A-3-62, which automatically voids certain contract clauses that violate State law.

46. ISRAEL BOYCOTT: Bidder understands and agrees that, pursuant to W. Va. Code § 5A-3-63, it is prohibited from engaging in a boycott of Israel during the term of this contract.

DESIGNATED CONTACT: Vendor appoints the individual identified in this Section as the Contract Administrator and the initial point of contact for matters relating to this Contract.

(Name, Title) Kimberly Jack , Inside Sales Coordinator
(Printed Name and Title) Kimberly Jack, Inside Sales Coordinator
(Address) 3479 Pollok Drive, Conroe TX 77303
(Phone Number) / (Fax Number) 418-654-1303 / 418-654-0517
(email address) kim.jack@ver-mac.com

CERTIFICATION AND SIGNATURE: By signing below, or submitting documentation through wvOASIS, I certify that: I have reviewed this Solicitation/Contract in its entirety; that I understand the requirements, terms and conditions, and other information contained herein; that this bid, offer or proposal constitutes an offer to the State that cannot be unilaterally withdrawn; that the product or service proposed meets the mandatory requirements contained in the Solicitation/Contract for that product or service, unless otherwise stated herein; that the Vendor accepts the terms and conditions contained in the Solicitation, unless otherwise stated herein; that I am submitting this bid, offer or proposal for review and consideration; that I am authorized by the vendor to execute and submit this bid, offer, or proposal, or any documents related thereto on vendor's behalf; that I am authorized to bind the vendor in a contractual relationship; and that to the best of my knowledge, the vendor has properly registered with any State agency that may require registration.

By signing below, I further certify that I understand this Contract is subject to the provisions of West Virginia Code § 5A-3-62, which automatically voids certain contract clauses that violate State law; and that pursuant to W. Va. Code 5A-3-63, the entity entering into this contract is prohibited from engaging in a boycott against Israel.

Ver-Mac Inc.

(Company) _____

 _____
Kimberly Jack, Inside Sales Coordinator

(Authorized Signature) (Representative Name, Title) _____

Kimberly Jack Inside Sales Coordinator

(Printed Name and Title of Authorized Representative) (Date) _____

418-654-1303 / 418-654-0517

(Phone Number) (Fax Number) _____
kim.jack@ver-mac.com

(Email Address) _____

EXHIBIT B

EQUIPMENT PREVENTATIVE MAINTENANCE QUESTIONNAIRE

THIS FORM MUST BE COMPLETED IN ITS ENTIRETY BY SUCCESSFUL BIDDER OR MANUFACTURER'S TECHNICAL REPRESENTATIVE PRIOR TO DELIVERY TO THE WVDOH.

DESCRIPTION: _____ MAKE: _____

MODEL: _____ YEAR: _____ PURCHASE AMOUNT: _____

ENGINE: MAKE: _____ MODEL: _____ FUEL TYPE: _____ GALLONS: _____

HORSEPOWER: _____ CYLINDER: _____ ENGINE SERIAL: _____

BELTS: DESCRIPTION: _____ PART NUMBERS: _____

DIMENSIONS OF UNIT: LENGTH: _____ WIDTH: _____ HEIGHT: _____

VENDOR CONTACT PERSON: _____ PHONE: _____

PARTS:

BATTERY MAKE: _____ MODEL: _____ CCA: _____

SPARK PLUGS OR FUEL INJECTORS MAKE: _____ PART # _____

FUEL PUMP OR INJECTION PUMP MAKE: _____ MODEL: _____

ALTERNATOR MAKE: _____ PART #: _____

STARTER MAKE: _____ PART #: _____

TURBO CHARGER MAKE: _____ PART #: _____

TRANS. MAKE: _____ MODEL: _____ AUTO/MANUAL: _____

HYDRAULIC PUMP MAKE: _____ MODEL: _____

FILTERS

MAKE

PART NO.

LUBRICANT

MANUFACTURER TYPE

OIL _____

AIR INNER _____

AIR OUTER _____

FUEL PRIMARY _____

FUEL SECONDARY _____

COOLANT _____

HYDRAULIC _____

OTHER _____

OTHER _____

OTHER _____

OTHER _____

ENGINE OIL WEIGHT _____

TRANSMISSION FLUID TYPE _____

POWER STEERING FLUID TYPE _____

HYDRAULIC OIL WEIGHT _____

DIFFERENTIALS OIL WEIGHT _____

BRAKE FLUID TYPE _____

COOLANT TYPE _____

OTHER _____

OTHER _____

OTHER _____

OTHER _____



VER-MAC

PRO

SERIES

ST-4815

TRAILER-MOUNTED ARROWBOARD

Ver-Mac's ST-4815 Pro Series is a trailer-mounted arrowboard with 15 LED lamps. It features our innovative Single-Mast Design, V-Switch controller, Stealth Technology, OptiBright technology and is wired to integrate the Smart Arrowboard option. The unit combines energy-efficient design and high-quality construction to provide the most reliable, cost-effective and safe to operate arrowboard on the market.

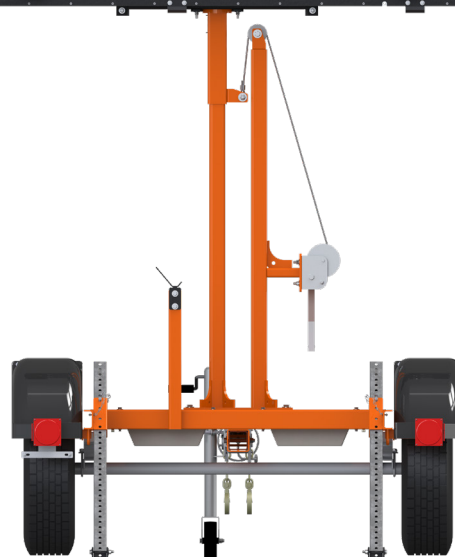
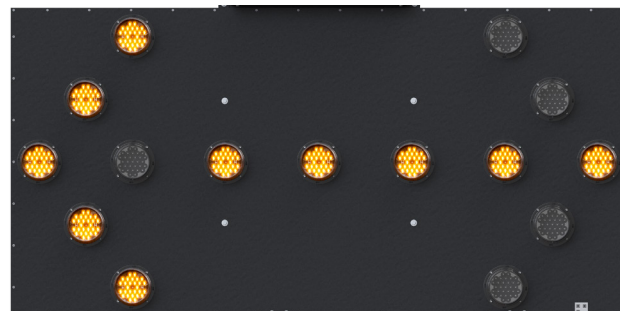

PRO SERIES FEATURES

STEALTH TECHNOLOGY

Maintenance-Free Battery
Anti-Theft Hidden Battery Compartment

OPTIBRIGHT TECHNOLOGY

Exclusive Energy-Efficient Lens Mold
Easier Replacement of Lamps
Autonomous No Hassle Performance.

IMPROVED SINGLE MAST DESIGN

Diamond Plate Maintenance Platform
Rugged Indexed Rod Mast Brake
Tongue Wheel Jack for easy and safe set up
Secure Support of Arrowboard for Transport
Safely Set and Turn Arrowboard to Traffic

V-SWITCH CONTROLLER

Easy-to-use rotary switch to quickly select arrow patterns/mode
Real-time arrow, solar & battery status
Lockable control box for more security
Photocell with automatic adjustment

SMART ARROWBOARD OPTION

Plug & Play Set up
Lane Closure Start Location
Mode Displayed on Arrow Sign
Road Name & Mile Marker Where Deployed
Direction of Traffic
Side of Road Where Deployed
Ability to retrofit existing arrowboards



V-Switch Controller

SINGLE-MAST DESIGN

ARROWBOARD PROTECTED IN TRAVEL POSITION

Safer to use and more efficient to store and transport

LOW CENTER OF GRAVITY REDUCES WIND DRAG

Saving fuel costs

QUICK AND EASY TO SET UP IN TIGHT WORK ZONES

Saving time

ANGLE THE ARROWBOARD INDEPENDENTLY TOWARDS TRAFFIC

Safely set and turn arrowboard to traffic

EASY MAINTENANCE PLATFORM

Diamond plates make it easy and safe to perform maintenance

HIGH-QUALITY CONSTRUCTION

POWDER COATING SUPERIOR FINISH

Impact, humidity, salt spray and rust resistant

4 ADJUSTABLE STABILIZER LEGS

For trailer stabilization and easy transportation

TONGUE WHEEL JACK

For easy and safe trailer set up

REMOVABLE TONGUE

Saves space for storage

MANUAL LIFT MECHANISM

For quick deployment

U-SHAPED CRADLE FOR ARROWBOARD

For better support during transportation

RUGGED INDEXED ROD MAST BRAKE

The arrow can be positioned on 209 degrees (17 deg. increments)

HEAVY-DUTY PLASTIC FENDERS

For durability and easy replacement

2-IN. (51 MM) COUPLER OR 3-IN. (76 MM) PINTLE EYE

For easy towing

ENERGY-EFFICIENT DESIGN

OPTIBRIGHT TECHNOLOGY

Exclusive lens mold designed for super efficient energy consumption



SOLAR PANEL

Provides maximum solar recharging during all four seasons.

SOLAR REGULATOR

Protects the batteries against overcharge, over-discharge and short circuits

- Designed to run 12 months in most regions without manual charging.

APPLICATIONS

- Highway construction
- Department of Transportation (DOT)
- City and county
- Utility
- Smart Work Zone

DISPLAY

- Arrowboard panel: 48 in. x 96 in. (1219 mm x 2438 mm)
- 15 LED lamps with OptiBright Technology
- 2 back LED lights
- 28 LEDs per lamp

DIMENSIONS AND WEIGHT

- Overall length: 134 in. (3415 mm)
- Overall width: 96 in. (2438 mm)
- Operating height : 135.5 in. (3442 mm)
- Travelling width: 70 in. (1788 mm)
- Travelling height: 93 in. (2362 mm)
- Weight (approx.): 420 kg (920 lb.)

OPTIONS

- Weatherproof battery charger
- Smart arrowboard
- Smart arrowboard retrofit

Other options are available to meet your needs.

WARRANTY

- 1 year on complete trailer
- 2 years on electronic components manufactured by Ver-Mac

