



The following documentation is an electronically-submitted vendor response to an advertised solicitation from the *West Virginia Purchasing Bulletin* within the Vendor Self-Service portal at *wvOASIS.gov*. As part of the State of West Virginia's procurement process, and to maintain the transparency of the bid-opening process, this documentation submitted online is publicly posted by the West Virginia Purchasing Division at *WVPurchasing.gov* with any other vendor responses to this solicitation submitted to the Purchasing Division in hard copy format.

Header @ 1

List View

- General Information**
- Contact
- Default Values
- Discount
- Document Information
- Clarification Request

Procurement Folder: 1009573

Procurement Type: Central Purchase Order

Vendor ID:

Legal Name: OCTANE FORKLIFTS INC

Alias/DBA:

Total Bid: \$36,597.00

Response Date:

Response Time:

Responded By User ID:

First Name:

Last Name:

Email:

Phone:

SO Doc Code: CRFQ

SO Dept: 0708

SO Doc ID: ABC2200000003

Published Date: 2/28/22

Close Date: 3/15/22

Close Time: 13:30

Status: Closed

Solicitation Description:

Total of Header Attachments: 1

Total of All Attachments: 1



Department of Administration
 Purchasing Division
 2019 Washington Street East
 Post Office Box 50130
 Charleston, WV 25305-0130

**State of West Virginia
 Solicitation Response**

Proc Folder: 1009573
Solicitation Description: RFQ- 3 HYSTER MODEL B60ZAC or EQUAL PALLET TRUCKS
Proc Type: Central Purchase Order

Solicitation Closes	Solicitation Response	Version
2022-03-15 13:30	SR 0708 ESR03022200000005257	1

VENDOR
 VS0000020242
 OCTANE FORKLIFTS INC

Solicitation Number: CRFQ 0708 ABC2200000003
Total Bid: 36597
Response Date: 2022-03-02
Response Time: 10:02:49
Comments:

FOR INFORMATION CONTACT THE BUYER

Joseph E Hager III
 (304) 558-2306
 joseph.e.hageriii@wv.gov

Vendor Signature X **FEIN#** **DATE**

All offers subject to all terms and conditions contained in this solicitation

Line	Comm Ln Desc	Qty	Unit Issue	Unit Price	Ln Total Or Contract Amount
1	RFQ- 3 HYSTER MODEL B60ZAC or EQUAL PALLET TRUCK	3.00000	EA	12199.000000	36597.00

Comm Code	Manufacturer	Specification	Model #
24101603			

Commodity Line Comments: 2021 OCTANE EP30A
MODEL 30A 6,000 lbs Capacity @ 24in Load Center
24V/280Ah Battery, Battery and Charger included,
48 Fork Length, 27 Across Forks,
Polyurethane Tires,

Extended Description:

RFQ- 3 HYSTER MODEL B60ZAC or EQUAL PALLET TRUCK
PER ATTACHED SPECIFICATIONS

1 March 2022

**State of West Virginia
ALCOHOL BEVERAGE
CONTROL COMMISSION
4TH FLOOR
900 PENNSYLVANIA AVE
CHARLESTON, WEST VIRGINIA
25302**

**Solicitation:
CFRQ 0708 ABC2200000003**

For the purposes of the aforementioned reference, OCTANE Forklifts, Inc. is proud to propose the following equipment to satisfy all outlined specifications, criteria, and standards as listed within the reference.



PROPOSED UNIT SALIENT CHARACTERISTICS



2021 OCTANE EP30A – *This equipment is manufactured in the United States of America*

MODEL 30A – 6,000 lbs Capacity @ 24in Load Center

24V/280Ah Battery, Battery and Charger included,

48" Fork Length, 27" Across Forks,

Polyurethane Tires,

12month/2,000hour Manufacturer's Warranty, Operator

- ***Shipping Included FOB 45 Days ARO***

****Final Assembly USA*(TAA, BAA, NAFTA/USMCA) Compliant***

J.R. Antczak President

JR@OctaneForklifts.com

OCTANE Forklifts, Inc.

4905 Lima Street

Denver, CO 80239, U.S.A.

DUNS (011723445) – CAGE (88NS0) – FEIN (26-1129432) SBE

OCTANE

Forklifts.

WALKIE RIDER PALLET JACK EP30A

- 6600 lbs. Capacity
- Forks 27x48
- German AC Drive Motor
- Curtis Instrument Controller
- Stability Casters
- Electromagnetic Braking
- Battery and Charger Included
- 3 Year Limited Warranty



www.OctaneForklifts.com

WALKIE RIDER

EP30A

Superior quality, maneuverable, compact, and durable for all your material handling applications.

WEIGHT CAPACITY: 6600 lbs.

LIFT HEIGHT: 9.17"

FORK LENGTH: 27x48"

TURNING RADIUS: 81.34"

BATTERY / CHARGER: 24V/280Ah,
Direct connect 110A 110VAC
plug-in automatic 24V/50A charger
(both included)

SPEED TRAVEL: 4.97 mph empty ; 4.66 mph loaded

LIFTING SPEED: 1.1 ips empty; .8 ips loaded

LOWERING SPEED: 1.5 ips empty; 1.5 ips loaded

DRIVE WHEELS: 9.84" x 2.95" polyurethane

LOAD WHEELS: 4.88 x 2.36" polyurethane

HYDRAULICS LIFTING MOTOR: 24V 2200 Watt lifting motor with hardened chrome moly steel for durability.

DRIVE MOTOR: 24V 3000 Watt drive motor for efficiency and high torque.

CONTROLLER: 24V provides performance through entire range of speed; Constant travel speed regardless of load; Battery discharge indicator combination gauge.

BRAKES: Electro-magnetic braking for secure stopping power; Electronic neutral braking for accurate control.

OPERATOR CONTROLS: Throttle, lifting, lowering, turtle mode and horn functions are in the ergonomic handle; turtle button; belly button reverse safety feature allows the unit to stop and reverse to avoid collision or injury.

CHASSIS AND MAST: Robotic Welding; Heavy duty steel for durability.



WALKIE RIDER

Model		EP30A
Power unit		Electric
Operation		Walkie
Rated traction weight	Q (LBS)	6600
Load center	c (Inch)	23.6
Axle center to fork face	x (Inch)	40.79
Wheelbase	y (Inch)	67.72
Service weight with battery	LBS	1720
Wheels type		PU
Driving wheel size	$\Phi \times w$ (Inch)	$\Phi 9.84 \times 2.95$
Bearing wheel size	$\Phi \times w$ (Inch)	$\Phi 3.23 \times 6.5$
additional wheels (dimensions)	$\Phi \times w$ (Inch)	$\Phi 4.88 \times 2.36$
Wheels, number front/rear (x = driven)		1x+2/2
Track width	b_{10} (Inch)	25.2
Track width	b_{11} (Inch)	17.91
Lift	h_3 (Inch)	9.17
The height of handle in the operation	h_{14} (Inch)	36.6/52.76
lowered height	h_{13} (Inch)	3.26
Overall length	l_1 (Inch)	88.58
Length to fork face	l_2 (Inch)	40.55
Overall width	b_1 / b_2 (Inch)	35.83
Fork dimensions	$s/e/l$ (Inch)	2.36/9.06/48.03
outside Width of forks	b_5 (Inch)	26.97
Min.Ground clearance	m_2 (Inch)	0.905
Aisle width with pallet 1000 x 1200 across forks	A_{st} (Inch)	96.46
Aisle width with pallet 800 x 1200 along forks	A_{st} (Inch)	100.39
Min.Turning radius	W_a (Inch)	81.34
Travel speed, laden/unladen	(km/h)	7.5/8
Lifting speed, with/without load	(m/s)	42/65
Lowering speed, with/without load	(m/s)	36/30
Maximum climbing ability, with/without load	(%)	5/15
Service brake		Electromagnetic
Drive motor, 60-minute rating	(kW)	3
Lift motor rating at S3 15%	(kW)	2.2
Battery according to DIN 43531/35/36 A,B,C,no		no
Battery voltage/rated capacity	(V/Ah)	24/280
Battery weight ($\pm 5\%$)	(LBS)	550
Type of drive control		AC
Noise level at operator's ear	(dB(A))	≤ 70
Steering type		EPS

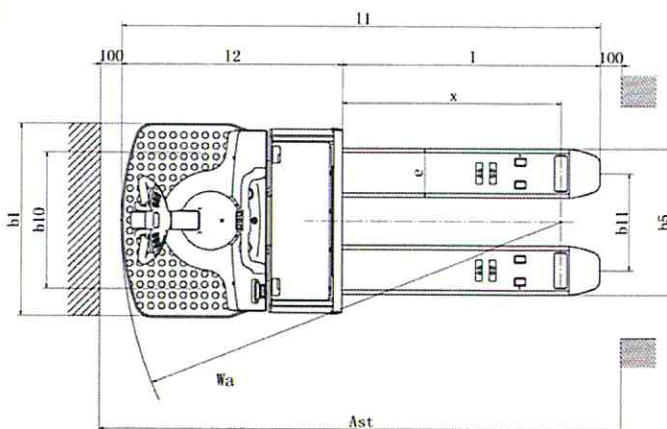
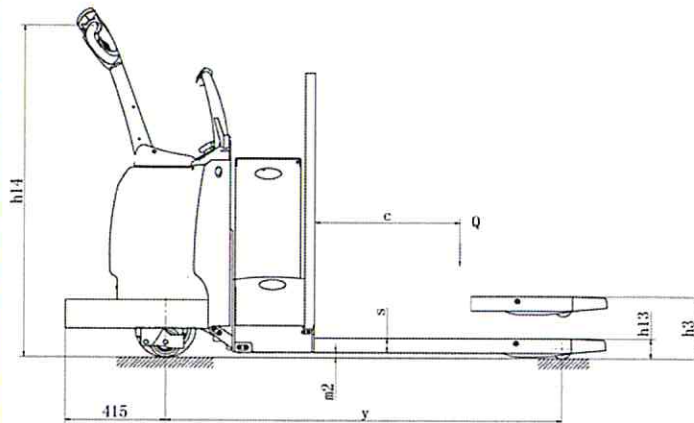

Octane

Forklifts

OCTANE Forklifts
4905 Lima Street
Denver, Colorado

Certificate of Compliance

Trade Agreement Act Buy American Act North American Free Trade Agreement FAR(s) 25 & 52 DFARS 252

January 1, 2022

To: Valued Customer

Re: Buy American Compliance

OCTANE Forklifts, Inc. products are manufactured in the USA and meet the guidelines established under the Trade Agreement Act, Buy American Act, North American Free Trade Agreement, and FAR(s) 25 & 52 and all subsections contained therein.

Where you see the American Flag on our products, in our catalog, and on our website, you can rest assured that the product shown meets the Trade Agreement Act, Buy American Act, North American Free Trade Agreement, and FAR(s) 25 & 52 and all subsections contained therein. The criteria within refers that "domestic manufactured end product" requires manufacture in the United States, but does not include a requirement with regard to the origin of the components used to make the end product. As such, OCTANE Forklifts, Inc. makes every reasonable effort to utilize American suppliers, American components, and American technology and expertise whenever possible in the production of its product line.

Since its inception, OCTANE Forklifts, Inc. recognizes the value of community and being a good neighbor. It is for this reason we promote and support the American Dream through employment, education, diversity, environmental health and safety, and community involvement. When you choose OCTANE Forklifts, Inc. you are buying American and you are investing in America. At OCTANE Forklifts, Inc. we are proud to be an American company who manufactures quality American products by being a Veterans-preference employer utilizing a workforce consisting of both civilians and disabled veterans.

Thank you for your support and thank you for choosing OCTANE Forklifts, Inc.!

52.225-6 Trade Agreements Certificate.

As prescribed in 25.1101(c)(2), insert the following provision:

Trade Agreements Certificate (MAY 2014)

- (a) The offeror certifies that each end product, except those listed in paragraph (b) of this provision, is a U.S.-made or designated country end product, as defined in the clause of this solicitation entitled "Trade Agreements."
- (b) The offeror shall list as other end products those supplies that are not U.S.-made or designated country end products.

Other End Products

Line Item No.:	Country of Origin:

(List as necessary),

- (c) The Government will evaluate offers in accordance with the policies and procedures of Part 25 of the Federal Acquisition Regulation. For line items covered by the WTO GPA, the Government will evaluate offers of U.S.-made or designated country end products without regard to the restrictions of the Buy American statute. The Government will consider for award only offers of U.S.-made or designated country end products unless the Contracting Officer determines that there are no offers for such products or that the offers for those products are insufficient to fulfill the requirements of this solicitation.

**OCTANE Forklifts, Inc. supplies products that are manufactured
and assembled in the United States of America.
We are in compliance with the Trade Agreements Act FAR 52.225-5**

Client Confidentiality Compliance Letter

January 1, 2022

To: Valued Customer

Re: Client Confidentiality Compliance Letter

Thank you for your interest in the OCTANE Forklifts, Inc. line. For the sake of respecting the privacy of our clients, we do not release customer information.

Due to the nature of OCTANE Forklifts, Inc.'s business and with whom we do business (DOD, DHS, Federal, State and Municipal powers) we do not and legally can not release any information with regard to our customer's identities. This includes information (up to and including) contract amounts, locations, representatives contact information and the subsequent fulfillment of said contracts. Client confidentiality is our utmost concern and legally can not be compromised.

As an approved Federal, State, County, Local, and Municipal entity vendor, OCTANE Forklifts Inc. frequently engage in contracts that contain confidentiality verbiage. This Verbiage binds us to non-disclosure of (but not limited to) agency name, destination location, purpose of purchase, nature of equipment deployment, intended use, buyer's name and contact information, value of contract and details about quantities or specifications of items being purchased.

We have done business with supplying our product and product lines to countless government agencies: Federal, State, and Municipal agencies including but not limited to, DHS - Department of Homeland Security, DOD-Department of Defense, DLA - Defense Logistics Agency, Department of the Army Department of the Navy, Department of the Air Force, Department of Justice, Bureau of Prisons, as well as Department of VeteranAffairs.

We are also in compliance with the TAA (Trade Agreement Act), BAA (Buy American Act), NAFTA (North American Free Trade Agreement) as well as FAR 25 & 52 and the confidentiality that is included in said regulations and agreements.

Thank you for your understanding, your support, and thank you for choosing OCTANE Forklifts, Inc.!

To respect our Client Confidentiality we can only differ you to a public website that has Federal information for past performance. www.FPDS.gov

OCTANE FORKLIFTS, INC. MANUFACTURER WARRANTY POLICY

This written document sets forth completely the entirety of all provisions, applications, conditions, implementations, results, and consequences of every aspect of the Express Warranty, Limitations of Warranty, Disclaimers of Warranty, Invalidity of Warranty, Exclusions of Warranty, and Extensions of Warranty ("Warranties") that OCTANE Forklifts (as "Seller") offers to those who/which purchase, from OCTANE Forklifts ("Buyer(s)"), any and all forklift machines; any and all equipment and devices that separately or in the aggregate perform or accommodate forklift operations or functions; and any and all parts and components of, for, or associated with forklift machines sold by OCTANE Forklifts ("Forklift(s)").

This written document wholly merges and fully integrates any and all other communications, expressions, implications, or representations of any kind (verbal, written, conduct-established, etc.) that could in any way relate to OCTANE Forklifts' Warranties. Any and all representations of any kind that are in any way inconsistent with Octane Forklift's written Warranties, as set forth in this written document, are null, void, and unenforceable; and such inconsistent representations shall not constitute, qualify, or in any way affect the written Warranties that OCTANE Forklifts provides to Buyers who purchase Forklifts.

Master Disclosure of the Exclusive Expressions, Limitations, and Disclaimers of the written Warranties:

OCTANE Forklifts' written Warranties, as set forth in this written document, are Warranties that OCTANE Forklifts provides in lieu of and in complete and final replacement and substitution of - all other express or implied warranties, including any and all aspects of any implied warranties of merchantability, fitness for a particular purpose, title or infringement, or any other obligation on the part of OCTANE Forklifts. This Master Disclosure of the written Warranties shall control comprehensively any and all aspects of the written Warranties and, accordingly, shall limit, qualify, and otherwise affect the subject, substance, content, context, interpretation/construction, application, implementation, results, and consequences of any and all aspects of the written Warranties.

Descriptions, other than those in this written document, do **NOT** create or constitute a warranty by description or otherwise have any legal effect.

Examples or demonstrator-models of Forklifts, that were or are exhibited to Buyers, are for general informational purposes only and do NOT create or constitute a warranty by sample/model, or otherwise have any legal effect. The Buyer's sole and exclusive remedy and OCTANE's sole and exclusive liability, with respect to ANY breach of the written Warranties, as set forth in this written document, shall be, at OCTANE's sole and exclusive option, the repair, refurbishment, or replacement of the defective or nonconforming Forklift (or part or component), as set forth below in writing.

1. Exclusive and Express Warranty Coverage and Coverage Limitations:

1.1 Limited Emissions Components for Powerplants - 3 years or 2500 hours. Related components include any engine parts related to the following systems: Air-Induction system. Fuel System. Ignition System. Exhaust Gas Recirculation Systems. Catalyst. Crankcase Ventilation Valves. Sensors. Electronic Control Units. Malfunction Indicator Light. Fuel Tank. Fuel Cap. Fuel Line. Fuel Line Fittings and Clamps. Pressure Relief Valves. Control Valves. Control Solenoids and Electronic Controls. Vacuum Control Diaphragms. Control Cables. Control Linkages. Purge Valves. Vapor Hoses. Liquid/Vapor Separator. Carbon Canister. Canister Mounting Brackets. Carburetor Purge Port Connector. * Emission related components also include any other part whose only purpose is to reduce emissions or whose failure will increase emissions without significantly degrading engine/equipment performance.

1.2 High-Cost Emissions Components for Motor: A component covered by the emissions-related warranty (as set forth above in writing) with a replacement cost, at a time of certification, that exceeds \$400. Components that are not directly involved with fuel control or the emission control system - as well as the accessories manufactured or supplied/attached by (and sold to OCTANE Forklifts for installation)

- will be free from defects in material and workmanship for a period of 1 year or 2000 hours, whichever occurs first. Replacement parts may be new, re-manufactured, reconditioned, or repaired depending on the specific component and particular circumstances involved.

All components used to meet standards are **warranted for the unexpired portion of the warranty period**. The warranty period begins on the date the forklift is delivered to the Buyer. However, if the forklift is first placed in service as a demonstrator, prior to sale, the warranty period begins on the date that the forklift was first placed into service, presale, as a demonstrator. The warranty covers **ONLY** malfunctions resulting from defects in material or workmanship.

1.3 Diesel Base Engine Warranty - 2 years or 2000 hours. Applicable to: Base Engine. *Not applicable to the A Series Engine.

1.4 Diesel Extended Major Component Warranty - 3 years or 4,000 hours. Applicable to: *Registered Parts Only Cylinder Block, Camshaft, Crankshaft, Connecting Rod. Coverage begins on the expiration of the Base Engine Warranty and ends at the time or hour limitation listed above, whichever comes first, after the warranty start date.

OCTANE FORKLIFTS, INC. MANUFACTURER WARRANTY POLICY

1.5 OCTANE Chassis /Non Emissions Related Warranty - This includes parts that are not related to emissions control.

1.6 OCTANE Limited Warranty - Applicable to the following: Forks, Wheel Hub, Wheel Rim, Mast, Overhead Guard, Muffler, Counter Weight, Steering Wheel, Gear Box, Driving Axle, Mast Bearing, Wheel Brake, Steering Axle, Redirector, Gear Pump, Flow Regulator, Chain, Sprocket, Lifting Cylinder, Tilting Cylinder, Control Valve, High pressure Hose, and Radiator.

1.7 Items that are guaranteed for six months or 1000 hours: Starting Battery, Starter Motor, Alternator, Electric Distributor, Clutch Cover and Release Bearing, Regulator, Dashboard, Sensors.

2. Warranty Disclaimers, Exclusions, and Invalidity:

2.1 The Warranties set forth in this written document do **NOT** cover: Malfunctions resulting from alterations that are not approved by OCTANE Forklifts; excessive use, misuse, or abuse; intentionally tortious or negligent operation, implementation, or application; or accident. Examples of Conditions that cause the Warranties to be invalid: Damage due to incorrect storage, negligent care, insufficient maintenance, or improper usage. Equipment modifications or replacement of items by individuals who are not authorized by OCTANE Forklifts. Damage from wrongful operation or overloading. Damage due to man-made hazard.

Please Note: No liability for incidental or consequential damages: OCTANE Forklifts is **NOT** liable for incidental or consequential damages resulting from breach of the written Warranties, as set forth in this written document, such as (by way of example and not limitation) loss of time or inconvenience; or the cost of labor for removal from or reinstallation of the Forklift component(s) or part(s).

Please Note Important Condition: At OCTANE Forklifts sole and exclusive discretion, OCTANE Forklifts has the right to require the Buyer to return to OCTANE Forklifts, for inspection and evaluation, any allegedly defective or malfunctioning components or parts, as an express condition on which warranty coverage will be strictly contingent.

2.2 Items that are NOT covered by warranty: Additional Labor Expenses; Additional Working Time; Fast-wear Parts, e.g.: wheels, rollers, bearings, etc.; Consumable items like oils, seals, etc.; Freight cost for replacement parts in Buyers' locations; Lights, fuses, wiring, etc.; Machine transportation costs completed to Buyers' locations; Loss of time, loss of revenue, loss of production, loss of machine use, loss of bid or contract, **and ANY and ALL other incidental or consequential damages.**

2.3 OCTANE Forklifts does NOT provide or include a replacement machine as part of any aspect of the coverage provided by the written Warranties.

3 Components and Parts Warranty-Return Procedure: Do not return any parts unless requested. Return parts must be cleaned and fully assembled. Parts must be shipped on a prepaid basis. OCTANE Forklifts will **NOT** accept a claim-application for warranty coverage, **if** OCTANE Forklifts requests the return of the subject components or parts, but OCTANE Forklifts does **NOT** receive the components/parts within **30 days** of the date on which OCTANE Forklifts emailed the return-request.

4 Claim-Application Requirements: All claim-applications for warranty coverage must be completed by the Buyer and received by OCTANE Forklifts, via email at: warranty@octaneforklifts.com

Email Text Requirements: In the emailed claim-application, the claimant must reference and identify, clearly and completely, the component(s) or part(s) for which the claimant is requesting coverage under the written Warranties.

Email Photo Requirements: The claimant must attach to the emailed claim-application one or more photos that disclose, clearly and legibly, the nameplate of the allegedly defective forklift. The attached photos must depict, clearly and obviously, the alleged defect or malfunction for which the claimant is requesting coverage under the written Warranties - and must do so in the context of the forklift's visibly-revealed condition and operational-environment. The photos must demonstrate, clearly and precisely, the orientation, position, and location of the component(s) or part(s) for which the claimant is requesting warranty coverage. The photos must reveal, clearly and legibly, the Serial Number, along with the Hour Meter with Hour Reading, for the component(s) or part(s) for which the claimant is requesting coverage under the written Warranties. A claimant also must attach to the emailed claim-application an accurate and exact copy of All Service, Maintenance, and Repair Records for the forklift (the machine, as a whole) and for all components and parts that were in any way serviced, maintained, and/or repaired, separate and apart from the forklift machine.

5 Warranty Claim Submission: A fully completed, photo-supported claim-application must be received, as an email that is ISP/server-designated as "received" by OCTANE Forklifts, at the above-provided email address and account, within 30 days of the date on which an applicable repair was completed. OCTANE Forklifts will deem incomplete, non-timely, and ineligible for coverage under the written Warranties, any and all claim-applications that OCTANE Forklifts receives on a date that is more than 30 days after the date on which the subject repair was completed.

OCTANE FORKLIFTS, INC. MANUFACTURER WARRANTY POLICY

There are no exceptions. Claim-applications that OCTANE Forklifts returns, "for correction and resubmission", must be corrected and received by OCTANE Forklifts, as above-described, within **30 days** after OCTANE Forklift emails to the claimant a returned, correction/resubmission email-reply. OCTANE Forklift will **NOT** accept claim-applications that OCTANE forklifts does **NOT** receive within 30 days after OCTANE Forklifts emails a returned, correction/resubmission email-reply. OCTANE Forklifts will provide to a claimant **ONLY two opportunities** to submit to OCTANE Forklifts a claim-application: (1) an original claim-application and (2) a correction/resubmission claim-application, which OCTANE Forklifts must receive strictly in compliance with the above-described procedure, requirements, and timeframe. **After** OCTANE Forklifts provides the above-described, **second** opportunity - the correction/resubmission opportunity, OCTANE Forklifts will **NOT** accept any claim application that is not resubmitted in **strict compliance** with the above-described procedure, requirements, and timeframe.

6 Warranty for Approved Attachments: Any warranty for attachments of which OCTANE Forklifts approves, **exclusively** consists of **ONLY** those warranties, **if any**, that the manufacturers (of the approved attachments) specifically and expressly provides. Claimants must submit to those manufacturers any claims for warranty coverage on the approved attachments.

7 Buyers' Inspection/Reporting Obligations: Buyers are obligated to engage in all commercially reasonable **due diligence** in discerning and evaluating the condition, integrity, and fitness of the forklifts; Buyers are required to do so, immediately, by performing a comprehensive and thorough **Reception-Inspection**, upon the arrival of a forklift at a Buyer's delivery reception location. Buyers must present to, **and resolve with**, the delivering trucking/cartage company, **exclusively**, all alleged damage to the forklift. Buyers must disclose clearly in an **Inspection-Report** any components or parts that the Inspection reveals to be missing or incomplete. OCTANE Forklifts must receive the completed Inspection-Reports within **three days** of the date on which the Buyer receives delivery of the forklift. OCTANE Forklifts will **NOT** accept for review and consideration any Inspection-Reports that are received by OCTANE Forklifts later than three days **after** the Buyer's Delivery Reception date.

Please Note Important Warranty Coverage Requirement: OCTANE Forklifts' timely and proper receipt of the Inspection Report, in strict compliance with the specific and expressly disclosed (above) requirements, procedure, and timeframe, is an express condition on which OCTANE Forklifts' obligation to provide any coverage, under the written Warranties, is strictly contingent.

The references, descriptions, definitions, and characterizations set forth in this written document - with respect to any and all machines, components, parts, coverage, requirements, conditions, availability, limitations, and other subjects and qualifiers - constitute information that is reasonably correct, realistically accurate, and practically applicable, but only to the extent, under the limitations, and within the qualifications and context of **what is specifically and expressly disclosed in this written document**.

The Buyers are obligated to act responsibly, in good faith, and in a commercially reasonable and diligent manner in purchasing, inspecting, possessing, maintaining, repairing, and implementing the forklifts, in all respects, within and outside of the coverage provided by the written Warranties. Accordingly, the Buyers are obligated to act prudently, carefully, competently, and actively to prevent the submission of groundless and improper warranty claims that, too often, result in needless disputes and unnecessary litigation. In that respect, the Buyers have an affirmative duty to comply with the provisions and requirements of the written Warranties, all contract provisions between OCTANE Forklifts and the Buyers, AND all acknowledged industry standards, established best-practices, and all duties at law.





CERTIFICATE OF LIABILITY INSURANCE

DATE (MM/DD/YYYY)

12/08/2021

THIS CERTIFICATE IS ISSUED AS A MATTER OF INFORMATION ONLY AND CONFERS NO RIGHTS UPON THE CERTIFICATE HOLDER. THIS CERTIFICATE DOES NOT AFFIRMATIVELY OR NEGATIVELY AMEND, EXTEND OR ALTER THE COVERAGE AFFORDED BY THE POLICIES BELOW. THIS CERTIFICATE OF INSURANCE DOES NOT CONSTITUTE A CONTRACT BETWEEN THE ISSUING INSURER(S), AUTHORIZED REPRESENTATIVE OR PRODUCER, AND THE CERTIFICATE HOLDER.

IMPORTANT: If the certificate holder is an ADDITIONAL INSURED, the policy(ies) must have ADDITIONAL INSURED provisions or be endorsed. If SUBROGATION IS WAIVED, subject to the terms and conditions of the policy, certain policies may require an endorsement. A statement on this certificate does not confer rights to the certificate holder in lieu of such endorsement(s).

PRODUCER Kris Pacey Insurance Agency, Inc. 11867 Bradburn Blvd Westminster, CO 80031	CONTACT NAME: Kris U Pacey	
	PHONE (A/C, No, Ext): 3034608844	FAX (A/C, No): 3034608845
E-MAIL ADDRESS: kpacey@farmersagent.com		
INSURED OCTANE Forklifts 4905 Lima St Denver, CO 80239-2615	INSURER(S) AFFORDING COVERAGE	
	INSURER A: Kinsale Insurance Company	
	INSURER B: Travelers Insurance	
	INSURER C: Kinsale Insurance Company	
	INSURER D: Atlantic Specialty Insurance Company	
	INSURER E: Pinnacle	
INSURER F:		

COVERAGES **CERTIFICATE NUMBER:** **REVISION NUMBER:**

THIS IS TO CERTIFY THAT THE POLICIES OF INSURANCE LISTED BELOW HAVE BEEN ISSUED TO THE INSURED NAMED ABOVE FOR THE POLICY PERIOD INDICATED. NOTWITHSTANDING ANY REQUIREMENT, TERM OR CONDITION OF ANY CONTRACT OR OTHER DOCUMENT WITH RESPECT TO WHICH THIS CERTIFICATE MAY BE ISSUED OR MAY PERTAIN, THE INSURANCE AFFORDED BY THE POLICIES DESCRIBED HEREIN IS SUBJECT TO ALL THE TERMS, EXCLUSIONS AND CONDITIONS OF SUCH POLICIES. LIMITS SHOWN MAY HAVE BEEN REDUCED BY PAID CLAIMS. ←

INSR LTR	TYPE OF INSURANCE	ADDL INSD	SUBR WVD	POLICY NUMBER	POLICY EFF (MM/DD/YYYY)	POLICY EXP (MM/DD/YYYY)	LIMITS
A	<input checked="" type="checkbox"/> COMMERCIAL GENERAL LIABILITY <input checked="" type="checkbox"/> CLAIMS-MADE <input type="checkbox"/> OCCUR GEN'L AGGREGATE LIMIT APPLIES PER: <input type="checkbox"/> POLICY <input type="checkbox"/> PROJECT <input type="checkbox"/> LOC OTHER:			0100135160-0	12/08/2021	12/08/2022	EACH OCCURRENCE \$ 1,000,000 DAMAGE TO RENTED PREMISES (Ea occurrence) \$ 100,000 MED EXP (Any one person) \$ 5,000 PERSONAL & ADV INJURY \$ 1,000,000 GENERAL AGGREGATE \$ 2,000,000 PRODUCTS - COMP/OP AGG \$ 2,000,000 \$
B	AUTOMOBILE LIABILITY <input type="checkbox"/> ANY AUTO <input type="checkbox"/> OWNED AUTOS ONLY <input type="checkbox"/> HIRED AUTOS ONLY <input checked="" type="checkbox"/> SCHEDULED AUTOS <input type="checkbox"/> NON-OWNED AUTOS ONLY			BA-6N971954-20-42-G	10/28/2021	10/28/2022	COMBINED SINGLE LIMIT (Ea accident) \$ 300,000 BODILY INJURY (Per person) \$ BODILY INJURY (Per accident) \$ PROPERTY DAMAGE (Per accident) \$ \$
C	<input checked="" type="checkbox"/> UMBRELLA LIAB <input type="checkbox"/> OCCUR <input checked="" type="checkbox"/> EXCESS LIAB <input type="checkbox"/> CLAIMS-MADE DED RETENTION \$			0100135242-0	12/08/2021	12/08/2022	EACH OCCURRENCE \$ 4,000,000 AGGREGATE \$ 4,000,000 \$
E	WORKERS COMPENSATION AND EMPLOYERS' LIABILITY ANY PROPRIETOR/PARTNER/EXECUTIVE OFFICER/MEMBER EXCLUDED? (Mandatory in NH) If yes, describe under DESCRIPTION OF OPERATIONS below	Y/N	N/A	AT 90-54637-12	03/08/2021	03/08/2022	PER STATUTE OTH-ER E.L. EACH ACCIDENT \$ 1,000,000 E.L. DISEASE - EA EMPLOYEE \$ 1,000,000 E.L. DISEASE - POLICY LIMIT \$ 1,000,000
D	Inland Marine			790-01-72-75-0006	05/23/2021	05/23/2022	Any one occur 2,300,000 newly acquired 50,000 Debris 25,000

DESCRIPTION OF OPERATIONS / LOCATIONS / VEHICLES (ACORD 101, Additional Remarks Schedule, may be attached if more space is required)
Forklift sales, repair and rental

CERTIFICATE HOLDER	CANCELLATION SHOULD ANY OF THE ABOVE DESCRIBED POLICIES BE CANCELLED BEFORE THE EXPIRATION DATE THEREOF, NOTICE WILL BE DELIVERED IN ACCORDANCE WITH THE POLICY PROVISIONS.
	AUTHORIZED REPRESENTATIVE Darien Schaefer

© 1988-2015 ACORD CORPORATION. All rights reserved.



Department of Administration
 Purchasing Division
 2019 Washington Street East
 Post Office Box 50130
 Charleston, WV 25305-0130

State of West Virginia
 Centralized Request for Quote
 Equipment

Proc Folder: 1009573			Reason for Modification:
Doc Description: RFQ- 3 HYSTER MODEL B60ZAC or EQUAL PALLET TRUCKS			
Proc Type: Central Purchase Order			
Date Issued	Solicitation Closes	Solicitation No	Version
2022-02-28	2022-03-15 13:30	CRFQ 0708 ABC2200000003	1

BID RECEIVING LOCATION

BID CLERK
 DEPARTMENT OF ADMINISTRATION
 PURCHASING DIVISION
 2019 WASHINGTON ST E
 CHARLESTON WV 25305
 US

VENDOR

Vendor Customer Code:

Vendor Name :

Address :

Street :

City :

State : **Country :** **Zip :**

Principal Contact :

Vendor Contact Phone: **Extension:**

FOR INFORMATION CONTACT THE BUYER
 Joseph E Hager III
 (304) 558-2306
 joseph.e.hageriii@wv.gov

Vendor Signature X **FEIN#** **DATE**

All offers subject to all terms and conditions contained in this solicitation

ADDITIONAL INFORMATION

The West Virginia Purchasing Division is soliciting bids on behalf of WV Alcohol Beverage Control Administration to establish a contract for the one time purchase of THREE (3) HYSTER MODEL B60ZAC (OR EQUAL) BATTERY POWERED PALLET TRUCK WALKIE/RIDER per the attached specifications and terms and conditions.

INVOICE TO		SHIP TO	
ALCOHOL BEVERAGE CONTROL COMMISSION 4TH FLOOR 900 PENNSYLVANIA AVE CHARLESTON US	WV	ABCA WAREHOUSE HUB INDUSTRIAL PARK 97 INDEPENDENT AVE NITRO US	WV

Line	Comm Ln Desc	Qty	Unit Issue	Unit Price	Total Price
1	RFQ- 3 HYSTER MODEL B60ZAC or EQUAL PALLET TRUCK	3.00000	EA		

Comm Code	Manufacturer	Specification	Model #
24101603			

Extended Description:

RFQ- 3 HYSTER MODEL B60ZAC or EQUAL PALLET TRUCK
PER ATTACHED SPECIFICATIONS

SCHEDULE OF EVENTS

<u>Line</u>	<u>Event</u>	<u>Event Date</u>
-------------	--------------	-------------------

INSTRUCTIONS TO VENDORS SUBMITTING BIDS

1. REVIEW DOCUMENTS THOROUGHLY: The attached documents contain a solicitation for bids. Please read these instructions and all documents attached in their entirety. These instructions provide critical information about requirements that if overlooked could lead to disqualification of a Vendor's bid. All bids must be submitted in accordance with the provisions contained in these instructions and the Solicitation. Failure to do so may result in disqualification of Vendor's bid.

2. MANDATORY TERMS: The Solicitation may contain mandatory provisions identified by the use of the words "must," "will," and "shall." Failure to comply with a mandatory term in the Solicitation will result in bid disqualification.

3. PREBID MEETING: The item identified below shall apply to this Solicitation.

A pre-bid meeting will not be held prior to bid opening

A **MANDATORY PRE-BID** meeting will be held at the following place and time:

All Vendors submitting a bid must attend the mandatory pre-bid meeting. Failure to attend the mandatory pre-bid meeting shall result in disqualification of the Vendor's bid. No one individual is permitted to represent more than one vendor at the pre-bid meeting. Any individual that does attempt to represent two or more vendors will be required to select one vendor to which the individual's attendance will be attributed. The vendors not selected will be deemed to have not attended the pre-bid meeting unless another individual attended on their behalf.

An attendance sheet provided at the pre-bid meeting shall serve as the official document verifying attendance. Any person attending the pre-bid meeting on behalf of a Vendor must list on the attendance sheet his or her name and the name of the Vendor he or she is representing.

Additionally, the person attending the pre-bid meeting should include the Vendor's E-Mail address, phone number, and Fax number on the attendance sheet. It is the Vendor's responsibility to locate the attendance sheet and provide the required information. Failure to complete the attendance sheet as required may result in disqualification of Vendor's bid.

All Vendors should arrive prior to the starting time for the pre-bid. Vendors who arrive after the starting time but prior to the end of the pre-bid will be permitted to sign in but are charged with knowing all matters discussed at the pre-bid.

Questions submitted at least five business days prior to a scheduled pre-bid will be discussed at the pre-bid meeting if possible. Any discussions or answers to questions at the pre-bid meeting
Revised 02/08/2022

are preliminary in nature and are non-binding. Official and binding answers to questions will be published in a written addendum to the Solicitation prior to bid opening.

4. VENDOR QUESTION DEADLINE: Vendors may submit questions relating to this Solicitation to the Purchasing Division. Questions must be submitted in writing. All questions must be submitted on or before the date listed below and to the address listed below to be considered. A written response will be published in a Solicitation addendum if a response is possible and appropriate. Non-written discussions, conversations, or questions and answers regarding this Solicitation are preliminary in nature and are nonbinding.

Submitted e-mails should have solicitation number in the subject line.

Question Submission Deadline: 03/07/2022 @ 4:00 PM ET

Submit Questions to: Josh Hager
2019 Washington Street, East
Charleston, WV 25305
Fax: (304) 558-3970
Email: Joseph.E.HagerIII@wv.gov

5. VERBAL COMMUNICATION: Any verbal communication between the Vendor and any State personnel is not binding, including verbal communication at the mandatory pre-bid conference. Only information issued in writing and added to the Solicitation by an official written addendum by the Purchasing Division is binding.

6. BID SUBMISSION: All bids must be submitted electronically through wvOASIS or signed and delivered by the Vendor to the Purchasing Division at the address listed below on or before the date and time of the bid opening. Any bid received by the Purchasing Division staff is considered to be in the possession of the Purchasing Division and will not be returned for any reason. The Purchasing Division will not accept bids, modification of bids, or addendum acknowledgment forms via e-mail. Acceptable delivery methods include electronic submission via wvOASIS, hand delivery, delivery by courier, or facsimile.

The bid delivery address is:
Department of Administration, Purchasing Division
2019 Washington Street East
Charleston, WV 25305-0130

A bid that is not submitted electronically through wvOASIS should contain the information listed below on the face of the envelope or the bid may be rejected by the Purchasing Division.:

SEALED BID: 3 Hyster Model B60ZAC ir Equal Pallet Trucks
BUYER: Josh Hager
SOLICITATION NO.: CRFQ 0708 ABC2200000003
BID OPENING DATE: See next page
BID OPENING TIME: See next page
FAX NUMBER: 304-558-3970

Revised 02/08/2022

The Purchasing Division may prohibit the submission of bids electronically through wvOASIS at its sole discretion. Such a prohibition will be contained and communicated in the wvOASIS system resulting in the Vendor's inability to submit bids through wvOASIS. Submission of a response to a Request for Proposal is not permitted in wvOASIS.

For Request For Proposal ("RFP") Responses Only: In the event that Vendor is responding to a request for proposal, the Vendor shall submit one original technical and one original cost proposal prior to the bid opening date and time identified in Section 7 below, plus NA convenience copies of each to the Purchasing Division at the address shown above. Additionally, the Vendor should clearly identify and segregate the cost proposal from the technical proposal in a separately sealed envelope.

7. BID OPENING: Bids submitted in response to this Solicitation will be opened at the location identified below on the date and time listed below. Delivery of a bid after the bid opening date and time will result in bid disqualification. For purposes of this Solicitation, a bid is considered delivered when confirmation of delivery is provided by wvOASIS (in the case of electronic submission) or when the bid is time stamped by the official Purchasing Division time clock (in the case of hand delivery).

Bid Opening Date and Time: 3/15/2022 @ 1:30 PM ET

Bid Opening Location: Department of Administration, Purchasing Division
2019 Washington Street East
Charleston, WV 25305-0130

8. ADDENDUM ACKNOWLEDGEMENT: Changes or revisions to this Solicitation will be made by an official written addendum issued by the Purchasing Division. Vendor should acknowledge receipt of all addenda issued with this Solicitation by completing an Addendum Acknowledgment Form, a copy of which is included herewith. Failure to acknowledge addenda may result in bid disqualification. The addendum acknowledgement should be submitted with the bid to expedite document processing.

9. BID FORMATTING: Vendor should type or electronically enter the information onto its bid to prevent errors in the evaluation. Failure to type or electronically enter the information may result in bid disqualification.

10. ALTERNATE MODEL OR BRAND: Unless the box below is checked, any model, brand, or specification listed in this Solicitation establishes the acceptable level of quality only and is not intended to reflect a preference for, or in any way favor, a particular brand or vendor. Vendors may bid alternates to a listed model or brand provided that the alternate is at least equal to the model or brand and complies with the required specifications. The equality of any alternate being bid shall be determined by the State at its sole discretion. Any Vendor bidding an alternate model or brand should clearly identify the alternate items in its bid and should include manufacturer's specifications, industry literature, and/or any other relevant documentation demonstrating the equality of the alternate items. Failure to provide information for alternate items may be grounds for rejection of a Vendor's bid.

This Solicitation is based upon a standardized commodity established under W. Va. Code § 5A-3-61. Vendors are expected to bid the standardized commodity identified. Failure to bid the standardized commodity will result in your firm's bid being rejected.

11. EXCEPTIONS AND CLARIFICATIONS: The Solicitation contains the specifications that shall form the basis of a contractual agreement. Vendor shall clearly mark any exceptions, clarifications, or other proposed modifications in its bid. Exceptions to, clarifications of, or modifications of a requirement or term and condition of the Solicitation may result in bid disqualification.

12. COMMUNICATION LIMITATIONS: In accordance with West Virginia Code of State Rules §148-1-6.6, communication with the State of West Virginia or any of its employees regarding this Solicitation during the solicitation, bid, evaluation or award periods, except through the Purchasing Division, is strictly prohibited without prior Purchasing Division approval. Purchasing Division approval for such communication is implied for all agency delegated and exempt purchases.

13. REGISTRATION: Prior to Contract award, the apparent successful Vendor must be properly registered with the West Virginia Purchasing Division and must have paid the \$125 fee, if applicable.

14. UNIT PRICE: Unit prices shall prevail in cases of a discrepancy in the Vendor's bid.

15. PREFERENCE: Vendor Preference may be requested in purchases of motor vehicles or construction and maintenance equipment and machinery used in highway and other infrastructure projects. Any request for preference must be submitted in writing with the bid, must specifically identify the preference requested with reference to the applicable subsection of West Virginia Code § 5A-3-37, and must include with the bid any information necessary to evaluate and confirm the applicability of the requested preference. A request form to help facilitate the request can be found at:

<http://www.state.wv.us/admin/purchase/vrc/Venpref.pdf>.

15A. RECIPROCAL PREFERENCE: The State of West Virginia applies a reciprocal preference to all solicitations for commodities and printing in accordance with W. Va. Code § 5A-3-37(b). In effect, non-resident vendors receiving a preference in their home states, will see that same preference granted to West Virginia resident vendors bidding against them in West Virginia. Any request for reciprocal preference must include with the bid any information necessary to evaluate and confirm the applicability of the preference. A request form to help facilitate the request can be found at: <http://www.state.wv.us/admin/purchase/vrc/Venpref.pdf>.

16. SMALL, WOMEN-OWNED, OR MINORITY-OWNED BUSINESSES: For any solicitations publicly advertised for bid, in accordance with West Virginia Code §5A-3-37(a)(7) and W. Va. CSR § 148-22-9, any non-resident vendor certified as a small, women-owned, or minority-owned business under W. Va. CSR § 148-22-9 shall be provided the same preference made available to any resident vendor. Any non-resident small, women-owned, or minority-owned business must identify itself as such in writing, must submit that writing to the Purchasing Division with its bid, and must be properly certified under W. Va. CSR § 148-22-9 prior to contract award to receive the preferences made available to resident vendors. Preference

for a non-resident small, women-owned, or minority owned business shall be applied in accordance with W. Va. CSR § 148-22-9.

17. WAIVER OF MINOR IRREGULARITIES: The Director reserves the right to waive minor irregularities in bids or specifications in accordance with West Virginia Code of State Rules § 148-1-4.6.

18. ELECTRONIC FILE ACCESS RESTRICTIONS: Vendor must ensure that its submission in wvOASIS can be accessed and viewed by the Purchasing Division staff immediately upon bid opening. The Purchasing Division will consider any file that cannot be immediately accessed and viewed at the time of the bid opening (such as, encrypted files, password protected files, or incompatible files) to be blank or incomplete as context requires and are therefore unacceptable. A vendor will not be permitted to unencrypt files, remove password protections, or resubmit documents after bid opening to make a file viewable if those documents are required with the bid. A Vendor may be required to provide document passwords or remove access restrictions to allow the Purchasing Division to print or electronically save documents provided that those documents are viewable by the Purchasing Division prior to obtaining the password or removing the access restriction.

19. NON-RESPONSIBLE: The Purchasing Division Director reserves the right to reject the bid of any vendor as Non-Responsible in accordance with W. Va. Code of State Rules § 148-1-5.3, when the Director determines that the vendor submitting the bid does not have the capability to fully perform or lacks the integrity and reliability to assure good-faith performance.”

20. ACCEPTANCE/REJECTION: The State may accept or reject any bid in whole, or in part in accordance with W. Va. Code of State Rules § 148-1-4.5. and § 148-1-6.4.b.”

21. YOUR SUBMISSION IS A PUBLIC DOCUMENT: Vendor’s entire response to the Solicitation and the resulting Contract are public documents. As public documents, they will be disclosed to the public following the bid/proposal opening or award of the contract, as required by the competitive bidding laws of West Virginia Code §§ 5A-3-1 et seq., 5-22-1 et seq., and 5G-1-1 et seq. and the Freedom of Information Act West Virginia Code §§ 29B-1-1 et seq.

DO NOT SUBMIT MATERIAL YOU CONSIDER TO BE CONFIDENTIAL, A TRADE SECRET, OR OTHERWISE NOT SUBJECT TO PUBLIC DISCLOSURE.

Submission of any bid, proposal, or other document to the Purchasing Division constitutes your explicit consent to the subsequent public disclosure of the bid, proposal, or document. The Purchasing Division will disclose any document labeled “confidential,” “proprietary,” “trade secret,” “private,” or labeled with any other claim against public disclosure of the documents, to include any “trade secrets” as defined by West Virginia Code § 47-22-1 et seq. All submissions are subject to public disclosure without notice.

22. INTERESTED PARTY DISCLOSURE: West Virginia Code § 6D-1-2 requires that the vendor submit to the Purchasing Division a disclosure of interested parties to the contract for all contracts with an actual or estimated value of at least \$1 million. That disclosure must occur on the form prescribed and approved by the WV Ethics Commission prior to contract award.

A copy of that form is included with this solicitation or can be obtained from the WV Ethics Commission. This requirement does not apply to publicly traded companies listed on a national or international stock exchange. A more detailed definition of interested parties can be obtained from the form referenced above.

23. WITH THE BID REQUIREMENTS: In instances where these specifications require documentation or other information with the bid, and a vendor fails to provide it with the bid, the Director of the Purchasing Division reserves the right to request those items after bid opening and prior to contract award pursuant to the authority to waive minor irregularities in bids or specifications under W. Va. CSR § 148-1-4.6. This authority does not apply to instances where state law mandates receipt with the bid.

24. EMAIL NOTIFICATION OF AWARD: The Purchasing Division will attempt to provide bidders with e-mail notification of contract award when a solicitation that the bidder participated in has been awarded. For notification purposes, bidders must provide the Purchasing Division with a valid email address in the bid response. Bidders may also monitor wvOASIS or the Purchasing Division's website to determine when a contract has been awarded.

GENERAL TERMS AND CONDITIONS:

1. CONTRACTUAL AGREEMENT: Issuance of an Award Document signed by the Purchasing Division Director, or his designee, and approved as to form by the Attorney General's office constitutes acceptance by the State of this Contract made by and between the State of West Virginia and the Vendor. Vendor's signature on its bid, or on the Contract if the Contract is not the result of a bid solicitation, signifies Vendor's agreement to be bound by and accept the terms and conditions contained in this Contract.

2. DEFINITIONS: As used in this Solicitation/Contract, the following terms shall have the meanings attributed to them below. Additional definitions may be found in the specifications included with this Solicitation/Contract.

2.1. "Agency" or "Agencies" means the agency, board, commission, or other entity of the State of West Virginia that is identified on the first page of the Solicitation or any other public entity seeking to procure goods or services under this Contract.

2.2. "Bid" or "Proposal" means the vendors submitted response to this solicitation.

2.3. "Contract" means the binding agreement that is entered into between the State and the Vendor to provide the goods or services requested in the Solicitation.

2.4. "Director" means the Director of the West Virginia Department of Administration, Purchasing Division.

2.5. "Purchasing Division" means the West Virginia Department of Administration, Purchasing Division.

2.6. "Award Document" means the document signed by the Agency and the Purchasing Division, and approved as to form by the Attorney General, that identifies the Vendor as the contract holder.

2.7. "Solicitation" means the official notice of an opportunity to supply the State with goods or services that is published by the Purchasing Division.

2.8. "State" means the State of West Virginia and/or any of its agencies, commissions, boards, etc. as context requires.

2.9. "Vendor" or "Vendors" means any entity submitting a bid in response to the Solicitation, the entity that has been selected as the lowest responsible bidder, or the entity that has been awarded the Contract as context requires.

3. CONTRACT TERM; RENEWAL; EXTENSION: The term of this Contract shall be determined in accordance with the category that has been identified as applicable to this Contract below:

Term Contract

Initial Contract Term: The Initial Contract Term will be for a period of _____. The Initial Contract Term becomes effective on the effective start date listed on the first page of this Contract and the Initial Contract Term ends on the effective end date also shown on the first page of this Contract.

Renewal Term: This Contract may be renewed upon the mutual written consent of the Agency, and the Vendor, with approval of the Purchasing Division and the Attorney General's office (Attorney General approval is as to form only). Any request for renewal should be delivered to the Agency and then submitted to the Purchasing Division thirty (30) days prior to the expiration date of the initial contract term or appropriate renewal term. A Contract renewal shall be in accordance with the terms and conditions of the original contract. Unless otherwise specified below, renewal of this Contract is limited to _____ successive one (1) year periods or multiple renewal periods of less than one year, provided that the multiple renewal periods do not exceed the total number of months available in all renewal years combined. Automatic renewal of this Contract is prohibited. Renewals must be approved by the Vendor, Agency, Purchasing Division and Attorney General's office (Attorney General approval is as to form only)

Alternate Renewal Term – This contract may be renewed for _____ successive _____ year periods or shorter periods provided that they do not exceed the total number of months contained in all available renewals. Automatic renewal of this Contract is prohibited. Renewals must be approved by the Vendor, Agency, Purchasing Division and Attorney General's office (Attorney General approval is as to form only)

Delivery Order Limitations: In the event that this contract permits delivery orders, a delivery order may only be issued during the time this Contract is in effect. Any delivery order issued within one year of the expiration of this Contract shall be effective for one year from the date the delivery order is issued. No delivery order may be extended beyond one year after this Contract has expired.

Fixed Period Contract: This Contract becomes effective upon Vendor's receipt of the notice to proceed and must be completed within _____ days.

Fixed Period Contract with Renewals: This Contract becomes effective upon Vendor's receipt of the notice to proceed and part of the Contract more fully described in the attached specifications must be completed within _____ days. Upon completion of the work covered by the preceding sentence, the vendor agrees that maintenance, monitoring, or warranty services will be provided for _____ year(s) thereafter.

One-Time Purchase: The term of this Contract shall run from the issuance of the Award Document until all of the goods contracted for have been delivered, but in no event will this Contract extend for more than one fiscal year.

Other: Contract Term specified in _____

4. AUTHORITY TO PROCEED: Vendor is authorized to begin performance of this contract on the date of encumbrance listed on the front page of the Award Document unless either the box for “Fixed Period Contract” or “Fixed Period Contract with Renewals” has been checked in Section 3 above. If either “Fixed Period Contract” or “Fixed Period Contract with Renewals” has been checked, Vendor must not begin work until it receives a separate notice to proceed from the State. The notice to proceed will then be incorporated into the Contract via change order to memorialize the official date that work commenced.

5. QUANTITIES: The quantities required under this Contract shall be determined in accordance with the category that has been identified as applicable to this Contract below.

Open End Contract: Quantities listed in this Solicitation/Award Document are approximations only, based on estimates supplied by the Agency. It is understood and agreed that the Contract shall cover the quantities actually ordered for delivery during the term of the Contract, whether more or less than the quantities shown.

Service: The scope of the service to be provided will be more clearly defined in the specifications included herewith.

Combined Service and Goods: The scope of the service and deliverable goods to be provided will be more clearly defined in the specifications included herewith.

One Time Purchase: This Contract is for the purchase of a set quantity of goods that are identified in the specifications included herewith. Once those items have been delivered, no additional goods may be procured under this Contract without an appropriate change order approved by the Vendor, Agency, Purchasing Division, and Attorney General’s office.

6. EMERGENCY PURCHASES: The Purchasing Division Director may authorize the Agency to purchase goods or services in the open market that Vendor would otherwise provide under this Contract if those goods or services are for immediate or expedited delivery in an emergency. Emergencies shall include, but are not limited to, delays in transportation or an unanticipated increase in the volume of work. An emergency purchase in the open market, approved by the Purchasing Division Director, shall not constitute of breach of this Contract and shall not entitle the Vendor to any form of compensation or damages. This provision does not excuse the State from fulfilling its obligations under a One Time Purchase contract.

7. REQUIRED DOCUMENTS: All of the items checked in this section must be provided to the Purchasing Division by the Vendor as specified:

BID BOND (Construction Only): Pursuant to the requirements contained in W. Va. Code § 5-22-1(c), All Vendors submitting a bid on a construction project shall furnish a valid bid bond in the amount of five percent (5%) of the total amount of the bid protecting the State of West Virginia. The bid bond must be submitted with the bid.

PERFORMANCE BOND: The apparent successful Vendor shall provide a performance bond in the amount of 100% of the contract. The performance bond must be received by the Purchasing Division prior to Contract award.

LABOR/MATERIAL PAYMENT BOND: The apparent successful Vendor shall provide a labor/material payment bond in the amount of 100% of the Contract value. The labor/material payment bond must be delivered to the Purchasing Division prior to Contract award.

In lieu of the Bid Bond, Performance Bond, and Labor/Material Payment Bond, the Vendor may provide certified checks, cashier's checks, or irrevocable letters of credit. Any certified check, cashier's check, or irrevocable letter of credit provided in lieu of a bond must be of the same amount and delivered on the same schedule as the bond it replaces. A letter of credit submitted in lieu of a performance and labor/material payment bond will only be allowed for projects under \$100,000. Personal or business checks are not acceptable. Notwithstanding the foregoing, West Virginia Code § 5-22-1 (d) mandates that a vendor provide a performance and labor/material payment bond for construction projects. Accordingly, substitutions for the performance and labor/material payment bonds for construction projects is not permitted.

MAINTENANCE BOND: The apparent successful Vendor shall provide a two (2) year maintenance bond covering the roofing system. The maintenance bond must be issued and delivered to the Purchasing Division prior to Contract award.

LICENSE(S) / CERTIFICATIONS / PERMITS: In addition to anything required under the Section of the General Terms and Conditions entitled Licensing, the apparent successful Vendor shall furnish proof of the following licenses, certifications, and/or permits upon request and in a form acceptable to the State. The request may be prior to or after contract award at the State's sole discretion.

The apparent successful Vendor shall also furnish proof of any additional licenses or certifications contained in the specifications regardless of whether or not that requirement is listed above.

8. INSURANCE: The apparent successful Vendor shall furnish proof of the insurance identified by a checkmark below and must include the State as an additional insured on each policy prior to Contract award. The insurance coverages identified below must be maintained throughout the life of this contract. Thirty (30) days prior to the expiration of the insurance policies, Vendor shall provide the Agency with proof that the insurance mandated herein has been continued. Vendor must also provide Agency with immediate notice of any changes in its insurance policies, including but not limited to, policy cancelation, policy reduction, or change in insurers. The apparent successful Vendor shall also furnish proof of any additional insurance requirements contained in the specifications prior to Contract award regardless of whether that insurance requirement is listed in this section.

Vendor must maintain:

Commercial General Liability Insurance in at least an amount of: \$1,000,000.00 per occurrence.

Automobile Liability Insurance in at least an amount of: _____ per occurrence.

Professional/Malpractice/Errors and Omission Insurance in at least an amount of: _____ per occurrence. Notwithstanding the forgoing, Vendor's are not required to list the State as an additional insured for this type of policy.

Commercial Crime and Third Party Fidelity Insurance in an amount of: _____ per occurrence.

Cyber Liability Insurance in an amount of: _____ per occurrence.

Builders Risk Insurance in an amount equal to 100% of the amount of the Contract.

Pollution Insurance in an amount of: _____ per occurrence.

Aircraft Liability in an amount of: _____ per occurrence.

Notwithstanding anything contained in this section to the contrary, the Director of the Purchasing Division reserves the right to waive the requirement that the State be named as an additional insured on one or more of the Vendor's insurance policies if the Director finds that doing so is in the State's best interest.

9. WORKERS' COMPENSATION INSURANCE: Vendor shall comply with laws relating to workers compensation, shall maintain workers' compensation insurance when required, and shall furnish proof of workers' compensation insurance upon request.

10. [Reserved]

11. LIQUIDATED DAMAGES: This clause shall in no way be considered exclusive and shall not limit the State or Agency's right to pursue any other available remedy. Vendor shall pay liquidated damages in the amount specified below or as described in the specifications:

_____ for _____.

Liquidated Damages Contained in the Specifications.

Liquidated Damages Are Not Included in this Contract.

12. ACCEPTANCE: Vendor's signature on its bid, or on the certification and signature page, constitutes an offer to the State that cannot be unilaterally withdrawn, signifies that the product or service proposed by vendor meets the mandatory requirements contained in the Solicitation for that product or service, unless otherwise indicated, and signifies acceptance of the terms and conditions contained in the Solicitation unless otherwise indicated.

13. PRICING: The pricing set forth herein is firm for the life of the Contract, unless specified elsewhere within this Solicitation/Contract by the State. A Vendor's inclusion of price adjustment provisions in its bid, without an express authorization from the State in the Solicitation to do so, may result in bid disqualification. Notwithstanding the foregoing, Vendor must extend any publicly advertised sale price to the State and invoice at the lower of the contract price or the publicly advertised sale price.

14. PAYMENT IN ARREARS: Payments for goods/services will be made in arrears only upon receipt of a proper invoice, detailing the goods/services provided or receipt of the goods/services, whichever is later. Notwithstanding the foregoing, payments for software maintenance, licenses, or subscriptions may be paid annually in advance.

15. PAYMENT METHODS: Vendor must accept payment by electronic funds transfer and P-Card. (The State of West Virginia's Purchasing Card program, administered under contract by a banking institution, processes payment for goods and services through state designated credit cards.)

16. TAXES: The Vendor shall pay any applicable sales, use, personal property or any other taxes arising out of this Contract and the transactions contemplated thereby. The State of West Virginia is exempt from federal and state taxes and will not pay or reimburse such taxes.

17. ADDITIONAL FEES: Vendor is not permitted to charge additional fees or assess additional charges that were not either expressly provided for in the solicitation published by the State of West Virginia, included in the Contract, or included in the unit price or lump sum bid amount that Vendor is required by the solicitation to provide. Including such fees or charges as notes to the solicitation may result in rejection of vendor's bid. Requesting such fees or charges be paid after the contract has been awarded may result in cancellation of the contract.

18. FUNDING: This Contract shall continue for the term stated herein, contingent upon funds being appropriated by the Legislature or otherwise being made available. In the event funds are not appropriated or otherwise made available, this Contract becomes void and of no effect beginning on July 1 of the fiscal year for which funding has not been appropriated or otherwise made available. If that occurs, the State may notify the Vendor that an alternative source of funding has been obtained and thereby avoid the automatic termination. Non-appropriation or non-funding shall not be considered an event of default.

19. CANCELLATION: The Purchasing Division Director reserves the right to cancel this Contract immediately upon written notice to the vendor if the materials or workmanship supplied do not conform to the specifications contained in the Contract. The Purchasing Division Director may also cancel any purchase or Contract upon 30 days written notice to the Vendor in accordance with West Virginia Code of State Rules § 148-1-5.2.b.

20. TIME: Time is of the essence regarding all matters of time and performance in this Contract.

21. APPLICABLE LAW: This Contract is governed by and interpreted under West Virginia law without giving effect to its choice of law principles. Any information provided in specification manuals, or any other source, verbal or written, which contradicts or violates the West Virginia Constitution, West Virginia Code, or West Virginia Code of State Rules is void and of no effect.

22. COMPLIANCE WITH LAWS: Vendor shall comply with all applicable federal, state, and local laws, regulations and ordinances. By submitting a bid, Vendor acknowledges that it has reviewed, understands, and will comply with all applicable laws, regulations, and ordinances.

SUBCONTRACTOR COMPLIANCE: Vendor shall notify all subcontractors providing commodities or services related to this Contract that as subcontractors, they too are required to comply with all applicable laws, regulations, and ordinances. Notification under this provision must occur prior to the performance of any work under the contract by the subcontractor.

23. ARBITRATION: Any references made to arbitration contained in this Contract, Vendor's bid, or in any American Institute of Architects documents pertaining to this Contract are hereby deleted, void, and of no effect.

24. MODIFICATIONS: This writing is the parties' final expression of intent. Notwithstanding anything contained in this Contract to the contrary no modification of this Contract shall be binding without mutual written consent of the Agency, and the Vendor, with approval of the Purchasing Division and the Attorney General's office (Attorney General approval is as to form only). Any change to existing contracts that adds work or changes contract cost, and were not included in the original contract, must be approved by the Purchasing Division and the Attorney General's Office (as to form) prior to the implementation of the change or commencement of work affected by the change.

25. WAIVER: The failure of either party to insist upon a strict performance of any of the terms or provision of this Contract, or to exercise any option, right, or remedy herein contained, shall not be construed as a waiver or a relinquishment for the future of such term, provision, option, right, or remedy, but the same shall continue in full force and effect. Any waiver must be expressly stated in writing and signed by the waiving party.

26. SUBSEQUENT FORMS: The terms and conditions contained in this Contract shall supersede any and all subsequent terms and conditions which may appear on any form documents submitted by Vendor to the Agency or Purchasing Division such as price lists, order forms, invoices, sales agreements, or maintenance agreements, and includes internet websites or other electronic documents. Acceptance or use of Vendor's forms does not constitute acceptance of the terms and conditions contained thereon.

27. ASSIGNMENT: Neither this Contract nor any monies due, or to become due hereunder, may be assigned by the Vendor without the express written consent of the Agency, the Purchasing Division, the Attorney General's office (as to form only), and any other government agency or office that may be required to approve such assignments.

28. WARRANTY: The Vendor expressly warrants that the goods and/or services covered by this Contract will: (a) conform to the specifications, drawings, samples, or other description furnished or specified by the Agency; (b) be merchantable and fit for the purpose intended; and (c) be free from defect in material and workmanship.

29. STATE EMPLOYEES: State employees are not permitted to utilize this Contract for personal use and the Vendor is prohibited from permitting or facilitating the same.

30. PRIVACY, SECURITY, AND CONFIDENTIALITY: The Vendor agrees that it will not disclose to anyone, directly or indirectly, any such personally identifiable information or other confidential information gained from the Agency, unless the individual who is the subject of the information consents to the disclosure in writing or the disclosure is made pursuant to the Agency's policies, procedures, and rules. Vendor further agrees to comply with the Confidentiality Policies and Information Security Accountability Requirements, set forth in <http://www.state.wv.us/admin/purchase/privacy/default.html>.

31. YOUR SUBMISSION IS A PUBLIC DOCUMENT: Vendor's entire response to the Solicitation and the resulting Contract are public documents. As public documents, they will be disclosed to the public following the bid/proposal opening or award of the contract, as required by the competitive bidding laws of West Virginia Code §§ 5A-3-1 et seq., 5-22-1 et seq., and 5G-1-1 et seq. and the Freedom of Information Act West Virginia Code §§ 29B-1-1 et seq.

DO NOT SUBMIT MATERIAL YOU CONSIDER TO BE CONFIDENTIAL, A TRADE SECRET, OR OTHERWISE NOT SUBJECT TO PUBLIC DISCLOSURE.

Submission of any bid, proposal, or other document to the Purchasing Division constitutes your explicit consent to the subsequent public disclosure of the bid, proposal, or document. The Purchasing Division will disclose any document labeled "confidential," "proprietary," "trade secret," "private," or labeled with any other claim against public disclosure of the documents, to include any "trade secrets" as defined by West Virginia Code § 47-22-1 et seq. All submissions are subject to public disclosure without notice.

32. LICENSING: In accordance with West Virginia Code of State Rules § 148-1-6.1.e, Vendor must be licensed and in good standing in accordance with any and all state and local laws and requirements by any state or local agency of West Virginia, including, but not limited to, the West Virginia Secretary of State's Office, the West Virginia Tax Department, West Virginia Insurance Commission, or any other state agency or political subdivision. Obligations related to political subdivisions may include, but are not limited to, business licensing, business and occupation taxes, inspection compliance, permitting, etc. Upon request, the Vendor must provide all necessary releases to obtain information to enable the Purchasing Division Director or the Agency to verify that the Vendor is licensed and in good standing with the above entities.

SUBCONTRACTOR COMPLIANCE: Vendor shall notify all subcontractors providing commodities or services related to this Contract that as subcontractors, they too are required to be licensed, in good standing, and up-to-date on all state and local obligations as described in this section. Obligations related to political subdivisions may include, but are not limited to, business licensing, business and occupation taxes, inspection compliance, permitting, etc. Notification under this provision must occur prior to the performance of any work under the contract by the subcontractor.

33. ANTITRUST: In submitting a bid to, signing a contract with, or accepting a Award Document from any agency of the State of West Virginia, the Vendor agrees to convey, sell, assign, or transfer to the State of West Virginia all rights, title, and interest in and to all causes of action it may now or hereafter acquire under the antitrust laws of the United States and the State of West Virginia for price fixing and/or unreasonable restraints of trade relating to the particular commodities or services purchased or acquired by the State of West Virginia. Such assignment shall be made and become effective at the time the purchasing agency tenders the initial payment to Vendor.

34. VENDOR CERTIFICATIONS: By signing its bid or entering into this Contract, Vendor certifies (1) that its bid or offer was made without prior understanding, agreement, or connection with any corporation, firm, limited liability company, partnership, person or entity submitting a bid or offer for the same material, supplies, equipment or services; (2) that its bid or offer is in all respects fair and without collusion or fraud; (3) that this Contract is accepted or entered into without any prior understanding, agreement, or connection to any other entity that could be considered a violation of law; and (4) that it has reviewed this Solicitation in its entirety; understands the requirements, terms and conditions, and other information contained herein.

Vendor's signature on its bid or offer also affirms that neither it nor its representatives have any interest, nor shall acquire any interest, direct or indirect, which would compromise the performance of its services hereunder. Any such interests shall be promptly presented in detail to the Agency. The individual signing this bid or offer on behalf of Vendor certifies that he or she is authorized by the Vendor to execute this bid or offer or any documents related thereto on Vendor's behalf; that he or she is authorized to bind the Vendor in a contractual relationship; and that, to the best of his or her knowledge, the Vendor has properly registered with any State agency that may require registration.

35. VENDOR RELATIONSHIP: The relationship of the Vendor to the State shall be that of an independent contractor and no principal-agent relationship or employer-employee relationship is contemplated or created by this Contract. The Vendor as an independent contractor is solely liable for the acts and omissions of its employees and agents. Vendor shall be responsible for selecting, supervising, and compensating any and all individuals employed pursuant to the terms of this Solicitation and resulting contract. Neither the Vendor, nor any employees or subcontractors of the Vendor, shall be deemed to be employees of the State for any purpose whatsoever. Vendor shall be exclusively responsible for payment of employees and contractors for all wages and salaries, taxes, withholding payments, penalties, fees, fringe benefits, professional liability insurance premiums, contributions to insurance and pension, or other deferred compensation plans, including but not limited to, Workers' Compensation and Social Security obligations, licensing fees, etc. and the filing of all necessary documents, forms, and returns pertinent to all of the foregoing.

Vendor shall hold harmless the State, and shall provide the State and Agency with a defense against any and all claims including, but not limited to, the foregoing payments, withholdings, contributions, taxes, Social Security taxes, and employer income tax returns.

36. INDEMNIFICATION: The Vendor agrees to indemnify, defend, and hold harmless the State and the Agency, their officers, and employees from and against: (1) Any claims or losses for services rendered by any subcontractor, person, or firm performing or supplying services, materials, or supplies in connection with the performance of the Contract; (2) Any claims or losses resulting to any person or entity injured or damaged by the Vendor, its officers, employees, or subcontractors by the publication, translation, reproduction, delivery, performance, use, or disposition of any data used under the Contract in a manner not authorized by the Contract, or by Federal or State statutes or regulations; and (3) Any failure of the Vendor, its officers, employees, or subcontractors to observe State and Federal laws including, but not limited to, labor and wage and hour laws.

37. PURCHASING AFFIDAVIT: In accordance with West Virginia Code §§ 5A-3-10a and 5-22-1(i), the State is prohibited from awarding a contract to any bidder that owes a debt to the State or a political subdivision of the State, Vendors are required to sign, notarize, and submit the Purchasing Affidavit to the Purchasing Division affirming under oath that it is not in default on any monetary obligation owed to the state or a political subdivision of the state.

38. CONFLICT OF INTEREST: Vendor, its officers or members or employees, shall not presently have or acquire an interest, direct or indirect, which would conflict with or compromise the performance of its obligations hereunder. Vendor shall periodically inquire of its officers, members and employees to ensure that a conflict of interest does not arise. Any conflict of interest discovered shall be promptly presented in detail to the Agency.

39. REPORTS: Vendor shall provide the Agency and/or the Purchasing Division with the following reports identified by a checked box below:

Such reports as the Agency and/or the Purchasing Division may request. Requested reports may include, but are not limited to, quantities purchased, agencies utilizing the contract, total contract expenditures by agency, etc.

Quarterly reports detailing the total quantity of purchases in units and dollars, along with a listing of purchases by agency. Quarterly reports should be delivered to the Purchasing Division via email at purchasing.division@wv.gov.

40. BACKGROUND CHECK: In accordance with W. Va. Code § 15-2D-3, the State reserves the right to prohibit a service provider's employees from accessing sensitive or critical information or to be present at the Capitol complex based upon results addressed from a criminal background check. Service providers should contact the West Virginia Division of Protective Services by phone at (304) 558-9911 for more information.

41. PREFERENCE FOR USE OF DOMESTIC STEEL PRODUCTS: Except when authorized by the Director of the Purchasing Division pursuant to W. Va. Code § 5A-3-56, no contractor may use or supply steel products for a State Contract Project other than those steel products made in the United States. A contractor who uses steel products in violation of this section may be subject to civil penalties pursuant to W. Va. Code § 5A-3-56. As used in this section:

- a. "State Contract Project" means any erection or construction of, or any addition to, alteration of or other improvement to any building or structure, including, but not limited to, roads or highways, or the installation of any heating or cooling or ventilating plants or other equipment, or the supply of and materials for such projects, pursuant to a contract with the State of West Virginia for which bids were solicited on or after June 6, 2001.
- b. "Steel Products" means products rolled, formed, shaped, drawn, extruded, forged, cast, fabricated or otherwise similarly processed, or processed by a combination of two or more or such operations, from steel made by the open heath, basic oxygen, electric furnace, Bessemer or other steel making process.
- c. The Purchasing Division Director may, in writing, authorize the use of foreign steel products if:

1. The cost for each contract item used does not exceed one tenth of one percent (.1%) of the total contract cost or two thousand five hundred dollars (\$2,500.00), whichever is greater. For the purposes of this section, the cost is the value of the steel product as delivered to the project; or
2. The Director of the Purchasing Division determines that specified steel materials are not produced in the United States in sufficient quantity or otherwise are not reasonably available to meet contract requirements.

42. PREFERENCE FOR USE OF DOMESTIC ALUMINUM, GLASS, AND STEEL: In Accordance with W. Va. Code § 5-19-1 et seq., and W. Va. CSR § 148-10-1 et seq., for every contract or subcontract, subject to the limitations contained herein, for the construction, reconstruction, alteration, repair, improvement or maintenance of public works or for the purchase of any item of machinery or equipment to be used at sites of public works, only domestic aluminum, glass or steel products shall be supplied unless the spending officer determines, in writing, after the receipt of offers or bids, (1) that the cost of domestic aluminum, glass or steel products is unreasonable or inconsistent with the public interest of the State of West Virginia, (2) that domestic aluminum, glass or steel products are not produced in sufficient quantities to meet the contract requirements, or (3) the available domestic aluminum, glass, or steel do not meet the contract specifications. This provision only applies to public works contracts awarded in an amount more than fifty thousand dollars (\$50,000) or public works contracts that require more than ten thousand pounds of steel products.

The cost of domestic aluminum, glass, or steel products may be unreasonable if the cost is more than twenty percent (20%) of the bid or offered price for foreign made aluminum, glass, or steel products. If the domestic aluminum, glass or steel products to be supplied or produced in a "substantial labor surplus area", as defined by the United States Department of Labor, the cost of domestic aluminum, glass, or steel products may be unreasonable if the cost is more than thirty percent (30%) of the bid or offered price for foreign made aluminum, glass, or steel products. This preference shall be applied to an item of machinery or equipment, as indicated above, when the item is a single unit of equipment or machinery manufactured primarily of aluminum, glass or steel, is part of a public works contract and has the sole purpose or of being a permanent part of a single public works project. This provision does not apply to equipment or machinery purchased by a spending unit for use by that spending unit and not as part of a single public works project.

All bids and offers including domestic aluminum, glass or steel products that exceed bid or offer prices including foreign aluminum, glass or steel products after application of the preferences provided in this provision may be reduced to a price equal to or lower than the lowest bid or offer price for foreign aluminum, glass or steel products plus the applicable preference. If the reduced bid or offer prices are made in writing and supersede the prior bid or offer prices, all bids or offers, including the reduced bid or offer prices, will be reevaluated in accordance with this rule.

43. INTERESTED PARTY SUPPLEMENTAL DISCLOSURE: W. Va. Code § 6D-1-2 requires that for contracts with an actual or estimated value of at least \$1 million, the vendor must submit to the Agency a supplemental disclosure of interested parties reflecting any new or differing interested parties to the contract, which were not included in the original pre-award interested party disclosure, within 30 days following the completion or termination of the contract. A copy of that form is included with this solicitation or can be obtained from the WV Ethics Commission. This requirement does not apply to publicly traded companies listed on a national or international stock exchange. A more detailed definition of interested parties can be obtained from the form referenced above.

44. PROHIBITION AGAINST USED OR REFURBISHED: Unless expressly permitted in the solicitation published by the State, Vendor must provide new, unused commodities, and is prohibited from supplying used or refurbished commodities, in fulfilling its responsibilities under this Contract.

45. VOID CONTRACT CLAUSES – This Contract is subject to the provisions of West Virginia Code § 5A-3-62, which automatically voids certain contract clauses that violate State law.

DESIGNATED CONTACT: Vendor appoints the individual identified in this Section as the Contract Administrator and the initial point of contact for matters relating to this Contract.

J.R. Antczak , President

(Name, Title)

J.R. Antczak President

(Printed Name and Title)

4905 Lima Street, Denver, Colorado 80239

(Address)

844-628-2637 / 303-997-6826

(Phone Number) / (Fax Number)

JR@OCTANEForklifts.com

(email address)

CERTIFICATION AND SIGNATURE: By signing below, or submitting documentation through wvOASIS, I certify that: I have reviewed this Solicitation in its entirety; that I understand the requirements, terms and conditions, and other information contained herein; that this bid, offer or proposal constitutes an offer to the State that cannot be unilaterally withdrawn; that the product or service proposed meets the mandatory requirements contained in the Solicitation for that product or service, unless otherwise stated herein; that the Vendor accepts the terms and conditions contained in the Solicitation, unless otherwise stated herein; that I am submitting this bid, offer or proposal for review and consideration; that I am authorized by the vendor to execute and submit this bid, offer, or proposal, or any documents related thereto on vendor's behalf; that I am authorized to bind the vendor in a contractual relationship; and that to the best of my knowledge, the vendor has properly registered with any State agency that may require registration.

By signing below, I further certify that I understand this Contract is subject to the provisions of West Virginia Code § 5A-3-62, which automatically voids certain contract clauses that violate State law.

OCTANE Forklifts Inc.

(Company)



(Authorized Signature) (Representative Name, Title)

J.R. Antczak President

(Printed Name and Title of Authorized Representative)

01MAR2022

(Date)

844-628-2637 / 303-997-6826

(Phone Number) (Fax Number)

ADDENDUM ACKNOWLEDGEMENT FORM
SOLICITATION NO.:

Instructions: Please acknowledge receipt of all addenda issued with this solicitation by completing this addendum acknowledgment form. Check the box next to each addendum received and sign below. Failure to acknowledge addenda may result in bid disqualification.

Acknowledgment: I hereby acknowledge receipt of the following addenda and have made the necessary revisions to my proposal, plans and/or specification, etc.

Addendum Numbers Received:

(Check the box next to each addendum received)

- | | |
|---|--|
| <input type="checkbox"/> Addendum No. 1 | <input type="checkbox"/> Addendum No. 6 |
| <input type="checkbox"/> Addendum No. 2 | <input type="checkbox"/> Addendum No. 7 |
| <input type="checkbox"/> Addendum No. 3 | <input type="checkbox"/> Addendum No. 8 |
| <input type="checkbox"/> Addendum No. 4 | <input type="checkbox"/> Addendum No. 9 |
| <input type="checkbox"/> Addendum No. 5 | <input type="checkbox"/> Addendum No. 10 |

I understand that failure to confirm the receipt of addenda may be cause for rejection of this bid. I further understand that any verbal representation made or assumed to be made during any oral discussion held between Vendor's representatives and any state personnel is not binding. Only the information issued in writing and added to the specifications by an official addendum is binding.

OCTANE Forklifts Inc.

Company

Authorized Signature

01MAR2022

Date

NOTE: This addendum acknowledgment should be submitted with the bid to expedite document processing.

REQUEST FOR QUOTATION
THREE (3) HYSTER MODEL B60ZAC (OR EQUAL) BATTERY POWERED PALLET
TRUCK WALKIE/RIDER

SPECIFICATIONS

1. **PURPOSE AND SCOPE:** The West Virginia Purchasing Division is soliciting bids on behalf of WV Alcohol Beverage Control Administration to establish a contract for the one time purchase of THREE (3) HYSTER MODEL B60ZAC (OR EQUAL) BATTERY POWERED PALLET TRUCK WALKIE/RIDER.

2. **DEFINITIONS:** The terms listed below shall have the meanings assigned to them below. Additional definitions can be found in section 2 of the General Terms and Conditions.

2.1 **“Contract Item”** means THREE (3) HYSTER MODEL B60ZAC 2022 (OR EQUAL) BATTERY POWERED HAND TRUCK WALKIE/RIDER as more fully described by these specifications.

2.2 **“Pricing Page”** means the pages, contained in wvOASIS or attached as Exhibit A, upon which Vendor should list its proposed price for the Contract Items.

2.3 **“Solicitation”** means the official notice of an opportunity to supply the State with goods or services that is published by the Purchasing Division.

3. **GENERAL REQUIREMENTS:**

3.1 **Mandatory Contract Item Requirements:** Contract Item must meet or exceed the mandatory requirements listed below.

3.1.1 THREE (3) HYSTER MODEL B60ZAC (OR EQUAL) BATTERY POWERED PALLET TRUCK WALKIE/RIDER.

LOAD CAPACITY	6000 LBS
FORK LENGTH	48 INCHES
LOWERED FORK HEIGHT	3.25 INCHES
FORK SPRED	27 INCHES
ELEVATED FORK HEIGHT	9.3 INCHES
INDIVIDUAL FORK WIDTH	9.0 INCHES
LIFT	6.0 INCHES
DRIVE WHEELS	10"X5" CROWNED POLY
LOAD WHEELS	3.25"X6.5" POLY
CASTER WHEELS	4"X2.5" POLY
ANTI-FATIGUE FLOOR MAT	
BATTERY CONNECTOR	SB 175 RED

REQUEST FOR QUOTATION
THREE (3) HYSTER MODEL B60ZAC (OR EQUAL) BATTERY POWERED PALLET
TRUCK WALKIE/RIDER

BATTERY – 24 VOLT 510 AMP HOURS- NOT TAR SEALED
CHARGER & ACCESSORIES
SERVICE MANUAL
PARTS MANUAL
CONTROL HANDLE WITH DAMPENED RETURN
BATTERY DISCHARGE INDICATOR WITH HOUR METER
12 MONTH/2000 HOUR WARRANTY
LOAD BACK REST NOT REQUIRED

3.1.1.1 THREE (3) HYSTER MODEL B60ZAC (OR EQUAL) BATTERY
POWERED PALLET TRUCK WALKIE/RIDER MUST BE
MODEL YEAR 2022 AND MUST BE NEW AND UNUSED.

3.1.1.2 MUST BE DELIVERED TO WVABCA DISTRIBUTION
CENTER LOCATED AT 97 INDEPENDENT AVENUE, HUB
INDUSTRIAL PARK, NITRO, WV 25143

3.1.1.3 MUST PROVIDE TRAINING AND CERTIFICATION TO
WVABCA STAFF

4. CONTRACT AWARD:

4.1 Contract Award: The Contract is intended to provide Agencies with a purchase price for the Contract Items. The Contract shall be awarded to the Vendor that provides the Contract Items meeting the required specifications for the lowest overall total cost as shown on the Pricing Pages.

5. PAYMENT:

5.1 Payment: Vendor shall accept payment in accordance with the payment procedures of the State of West Virginia.

REQUEST FOR QUOTATION
THREE (3) HYSTER MODEL B60ZAC (OR EQUAL) BATTERY POWERED PALLET
TRUCK WALKIE/RIDER

6. DELIVERY AND RETURN:

6.1 Shipment and Delivery: Vendor shall ship the Contract Items immediately after being awarded this Contract and receiving a purchase order or notice to proceed. Vendor shall deliver the Contract Items within Ninety (90) working days after receiving a purchase order or notice to proceed. Contract Items must be delivered to Agency at **WVABCA DISTRIBUTION CENTER, 97 Independent Avenue, Hub Industrial Park, Nitro, WV 25143.**

6.2 Late Delivery: The Agency placing the order under this Contract must be notified in writing if the shipment of the Contract Items will be delayed for any reason. Any delay in delivery that could cause harm to an Agency will be grounds for cancellation of the Contract, and/or obtaining the Contract Items from a third party.

Any Agency seeking to obtain the Contract Items from a third party under this provision must first obtain approval of the Purchasing Division.

6.3 Delivery Payment/Risk of Loss: Vendor shall deliver the Contract Items F.O.B. destination to the Agency's location.

6.4 Return of Unacceptable Items: If the Agency deems the Contract Items to be unacceptable, the Contract Items shall be returned to Vendor at Vendor's expense and with no restocking charge. Vendor shall either make arrangements for the return within five (5) days of being notified that items are unacceptable, or permit the Agency to arrange for the return and reimburse Agency for delivery expenses. If the original packaging cannot be utilized for the return, Vendor will supply the Agency with appropriate return packaging upon request. All returns of unacceptable items shall be F.O.B. the Agency's location. The returned product shall either be replaced, or the Agency shall receive a full credit or refund for the purchase price, at the Agency's discretion.

6.5 Return Due to Agency Error: Items ordered in error by the Agency will be returned for credit within 30 days of receipt, F.O.B. Vendor's location. Vendor shall not charge a restocking fee if returned products are in a resalable condition. Items shall be deemed to be in a resalable condition if they are unused and in the original packaging. Any restocking fee for items not in a resalable condition shall be the lower of the Vendor's customary restocking fee or 5% of the total invoiced value of the returned items.

REQUEST FOR QUOTATION
THREE (3) HYSTER MODEL B60ZAC (OR EQUAL) BATTERY POWERED PALLET
TRUCK WALKIE/RIDER

7 VENDOR DEFAULT:

7.1 The following shall be considered a vendor default under this Contract.

7.1.1 Failure to provide Contract Items in accordance with the requirements contained herein.

7.1.2 Failure to comply with other specifications and requirements contained herein.

7.1.3 Failure to comply with any laws, rules, and ordinances applicable to the Contract Services provided under this Contract.

7.1.4 Failure to remedy deficient performance upon request.

7.2 The following remedies shall be available to Agency upon default.

7.2.1 Immediate cancellation of the Contract.

7.2.2 Immediate cancellation of one or more release orders issued under this Contract.

7.2.3 Any other remedies available in law or equity.

STATE OF WEST VIRGINIA
Purchasing Division

PURCHASING AFFIDAVIT

CONSTRUCTION CONTRACTS: Under W. Va. Code § 5-22-1(i), the contracting public entity shall not award a construction contract to any bidder that is known to be in default on any monetary obligation owed to the state or a political subdivision of the state, including, but not limited to, obligations related to payroll taxes, property taxes, sales and use taxes, fire service fees, or other fines or fees.

ALL CONTRACTS: Under W. Va. Code §5A-3-10a, no contract or renewal of any contract may be awarded by the state or any of its political subdivisions to any vendor or prospective vendor when the vendor or prospective vendor or a related party to the vendor or prospective vendor is a debtor and: (1) the debt owed is an amount greater than one thousand dollars in the aggregate; or (2) the debtor is in employer default.

EXCEPTION: The prohibition listed above does not apply where a vendor has contested any tax administered pursuant to chapter eleven of the W. Va. Code, workers' compensation premium, permit fee or environmental fee or assessment and the matter has not become final or where the vendor has entered into a payment plan or agreement and the vendor is not in default of any of the provisions of such plan or agreement.

DEFINITIONS:

"Debt" means any assessment, premium, penalty, fine, tax or other amount of money owed to the state or any of its political subdivisions because of a judgment, fine, permit violation, license assessment, defaulted workers' compensation premium, penalty or other assessment presently delinquent or due and required to be paid to the state or any of its political subdivisions, including any interest or additional penalties accrued thereon.

"Employer default" means having an outstanding balance or liability to the old fund or to the uninsured employers' fund or being in policy default, as defined in W. Va. Code § 23-2c-2, failure to maintain mandatory workers' compensation coverage, or failure to fully meet its obligations as a workers' compensation self-insured employer. An employer is not in employer default if it has entered into a repayment agreement with the Insurance Commissioner and remains in compliance with the obligations under the repayment agreement.

"Related party" means a party, whether an individual, corporation, partnership, association, limited liability company or any other form or business association or other entity whatsoever, related to any vendor by blood, marriage, ownership or contract through which the party has a relationship of ownership or other interest with the vendor so that the party will actually or by effect receive or control a portion of the benefit, profit or other consideration from performance of a vendor contract with the party receiving an amount that meets or exceeds five percent of the total contract amount.

AFFIRMATION: By signing this form, the vendor's authorized signer affirms and acknowledges under penalty of law for false swearing (W. Va. Code §61-5-3) that: (1) for construction contracts, the vendor is not in default on any monetary obligation owed to the state or a political subdivision of the state, and (2) for all other contracts, that neither vendor nor any related party owe a debt as defined above and that neither vendor nor any related party are in employer default as defined above, unless the debt or employer default is permitted under the exception above.

WITNESS THE FOLLOWING SIGNATURE:

Vendor's Name: OCTANE Forklifts Inc.

Authorized Signature:  Date: 01MAR2022

State of Colorado

County of Denver, to-wit:

Taken, subscribed, and sworn to before me this 1 day of March, 2022.

My Commission expires 10.25.2022 ~~2022~~.

AFFIX SEAL HERE

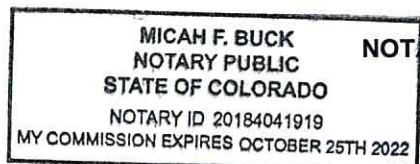

NOTARY PUBLIC

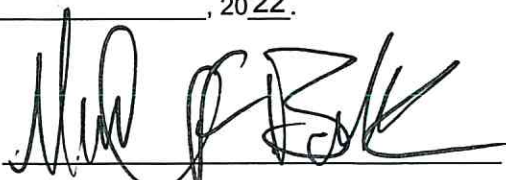

Purchasing Affidavit (Revised 01/19/2018)