



Department of Administration  
Purchasing Division  
2019 Washington Street East  
Post Office Box 50130  
Charleston, WV 25305-0130

State of West Virginia  
Centralized Request for Quote  
Public Safety

<b>Proc Folder:</b> 843503	<b>Reason for Modification:</b>
<b>Doc Description:</b> ADDENDUM NO_1 WHELEN LIGHTING PRODUCTS OR EQUAL	ADDENDUM NO_1 To attach Pre-bid sign in Sheets
<b>Proc Type:</b> Central Master Agreement	

Date Issued	Solicitation Closes	Solicitation No	Version
2021-04-22	2021-05-04 13:30	CRFQ 0803 DOT2100000123	2

**BID RECEIVING LOCATION**

BID CLERK  
DEPARTMENT OF ADMINISTRATION  
PURCHASING DIVISION  
2019 WASHINGTON ST E  
CHARLESTON WV 25305  
US

RECEIVED  
05/03/21 09:37:58  
WV PURCHASING DIVISION

**VENDOR**

**Vendor Customer Code:**  
**Vendor Name :** General Sales Administration, Inc. t/a Major Police Supply  
**Address :** 47 N. Dell Avenue, Kenil, NJ 07847  
**Street :** 47 N. Dell Avenue  
**City :** Kenil  
**State :** New Jersey **Country :** USA **Zip :** 07847  
**Principal Contact :** Gregg Glenn  
**Vendor Contact Phone:** 410-627-1187 **Extension:**

**FOR INFORMATION CONTACT THE BUYER**

John W Estep  
304-558-2566  
john.w.estep@wv.gov

Vendor  
Signature X

FEIN# 22-3004242

DATE

4/28/21

All offers subject to all terms and conditions contained in this solicitation

**ADDITIONAL INFORMATION****ADDENDUM NO\_1**

Addendum No\_1 Issued to publish and distribute the attached information to the Vendor Community

**REQUEST FOR QUOTATION :**

The West Virginia Purchasing Division is soliciting bids on behalf of the West Virginia Division of Highways, Department of Transportation Equipment Division to establish an open-end contract for Whelen lighting products or equal. Per the Bid Requirements, Specifications, Terms and Conditions attached to this Solicitation.

**INVOICE TO****SHIP TO**

DIVISION OF HIGHWAYS  
EQUIPMENT DIVISION RT 33  
83 BRUSHY ROAD  
CROSSING, PO BOX 610  
BUCKHANNON WV  
US

DIVISION OF HIGHWAYS  
EQUIPMENT DIVISION  
83 BRUSHY FORK RD  
CROSSING  
BUCKHANNON WV  
US

Line	Comm Ln Desc	Qty	Unit Issue	Unit Price	Total Price
1	Strobe or warning lights	0.00000	EA		

**Comm Code****Manufacturer****Specification****Model #**

39111706

**Extended Description:**

Strobe or warning lights

**SCHEDULE OF EVENTS**

<u>Line</u>	<u>Event</u>	<u>Event Date</u>
1	Prebid Meeting - Equip Div Conf Room @ 10:00am	2021-04-21
2	Tech Questions due by 10:00am	2021-04-28

	Document Phase	Document Description	Page
DOT2100000123	Final	ADDENDUM NO_1 WHELEN LIGHTING PRODUCTS OR EQUAL	3

**ADDITIONAL TERMS AND CONDITIONS**

See attached document(s) for additional Terms and Conditions

# SOLICITATION NUMBER: CRFQ DOT2100000123

## Addendum Number: 1

The purpose of this addendum is to modify the solicitation identified as CRFQ DOT2100000123 (“Solicitation”) to reflect the change(s) identified and described below.

### Applicable Addendum Category:

- Modify bid opening date and time
- Modify specifications of product or service being sought
- Attachment of vendor questions and responses
- Attachment of pre-bid sign-in sheet
- Correction of error
- Other

### Additional Documentation:

1. To attach Pre-bid sign in sheets

Bid Opening remains 05/04/21 at 1:30pm

### Terms and Conditions:

1. All provisions of the Solicitation and other addenda not modified herein shall remain in full force and effect.
2. Vendor should acknowledge receipt of all addenda issued for this Solicitation by completing an Addendum Acknowledgment, a copy of which is included herewith. Failure to acknowledge addenda may result in bid disqualification. The addendum acknowledgement should be submitted with the bid to expedite document processing.

# Pre-Bid Sign-In Sheet

Solicitation Number: DOT 21 \* 123  
 Date of Pre-Bid Meeting: \_\_\_\_\_  
 Location of Prebid Meeting: Buckhannon, WV

**Please Note:**

Vendors must sign-in on this sheet to verify attendance at the Pre-Bid meeting.  
 Failure to legibly sign in may be grounds for declaring a vendor ineligible to bid.  
 For further verification, please also provide a business card if possible.

Firm Represented:*	Rep Name (Printed):	Firm Address:	Telephone #:	Fax #:	Email:
HOLSTEIN AND ASSOCIATES	ANON MANINI	9031 HERITAGE DR. PLAIN CITY, OH 43064	614 282 8419 614 873 2121	614 875 3095	ANTON@ HOLSTEINANDASSOCIATES.COM
Whelan Engineering Co Inc	Andrew Predzimirski	51 Wintthrop Rd CHESTER, CT 06412	860 395 8716 860 526 9504	860 526 4078	apredzimirski@ whelan.com
Holstein AND ASSOCIATES	SCOTT Holstein	9031 Heritage DR Plain City OH 43064	614-395-990 614-873-2121	614 873-3095	Scott@ Holsteinandassociates.com
Major Police Supply	Kevin Good	47 N. Pell Ave Kenil, NJ 07847	973-584-7714 202-875-4042	977-584-5022	Kgood@majorpolicesupply.com
W.V. SIGNAL + LIGHT	LENDEL PARKINS	247 KENTUCK ROAD KENNA, W.V. 25248	304-372-9648 304-786-1512	304-372-9684	LENDEL WVSL @ AOL.COM
WDOH	JO Haller		304-471-0141		

*\*One Vendor Per Representative - No one individual is permitted to represent more than one vendor at the pre-bid meeting. Any individual that does attempt to represent two or more vendors will be required to select one vendor to which the individual's attendance will be attributed. The vendors not selected will be deemed to have not attended the pre-bid meeting unless another individual attended on their behalf.*

# Pre-Bid Sign-In Sheet

Solicitation Number: DOT 21\*123

Date of Pre-Bid Meeting: \_\_\_\_\_

Location of Prebid Meeting: Buckhannon WV

**Please Note:**

Vendors must sign-in on this sheet to verify attendance at the Pre-Bid meeting.  
 Failure to legibly sign in may be grounds for declaring a vendor ineligible to bid.  
 For further verification, please also provide a business card if possible.

Firm Represented:*	Rep Name (Printed):	Firm Address:	Telephone #:	Fax #:	Email:
WV DOT/DOH	MARK A. WAID	1900 Kanawha Blvd Building 5 Charleston, WV 25305	304.414.7105		MARK.A.WAID@WV.GOV

**\*One Vendor Per Representative - No one individual is permitted to represent more than one vendor at the pre-bid meeting. Any individual that does attempt to represent two or more vendors will be required to select one vendor to which the individual's attendance will be attributed. The vendors not selected will be deemed to have not attended the pre-bid meeting unless another individual attended on their behalf.**



# MAJOR POLICE SUPPLY

A Division of GENERAL SALES ADMINISTRATION

EMERGENCY VEHICLE EQUIPMENT SPECIALISTS  
SALES • INSTALLATIONS • REPAIRS

**KEVIN GOOD**  
Government Sales

kgood@majorpolicesupply.com  
Tel: (973) 584-7714  
Fax: (973) 584-5022  
Cell: (202) 675-4042  
47 N. Dell Avenue • Kenvil, NJ 07847

**Andrew Predzimirski**  
DOT Sales Manager  
apredzimirski@whelen.com  
(860) 395-8716

Whelen Engineering  
whelen.com  
U.S.A.

**Lendel Parkins**  
Vice-President  
lendel@wvsl.com

**West Virginia Signal & Light, Inc.**

P.O. Box 134  
247 Kentuck Road  
Kenra, WV 25248

Ph: 304-372-9648  
Fx: 304-372-9684  
Cell 304-532-0583

**WHELEN**  
TRUSTED TO PERFORM

Anton Manini

Phone 614-873-2121  
Fax 614-873-3095  
Cell 614-282-8449

anton@holsteinandassociates.com  
www.holsteinandassociates.com



Holstein & Associates  
Manufacturers' Representatives  
9031 Heritage Drive  
Plain City, Ohio 43064

**Holstein & Associates**

Manufacturers' Representatives

9031 Heritage Drive • Plain City, Ohio 43064

**Scott Holstein**  
Principal

Phone 614-873-2121  
Fax 614-873-3095  
scott@holsteinandassociates.com

**WHELEN**  
TRUSTED TO PERFORM

**HAVIS**

**Pro-gard**



**Anton Manini**

Phone 614-873-2121  
Fax 614-873-3095  
Cell 614-282-8449

anton@holsteinandassociates.com  
www.holsteinandassociates.com



**Holstein & Associates**  
Manufacturers' Representatives  
9031 Heritage Drive  
Plain City, Ohio 43064

**Holstein & Associates**  
Manufacturers' Representatives

9031 Heritage Drive • Plain City, Ohio 43064

**Scott Holstein**  
Principal

Phone 614-873-2121  
Fax 614-873-3095  
scott@holsteinandassociates.com



**MAJOR POLICE SUPPLY**

A Division of GENERAL SALES ADMINISTRATION  
EMERGENCY VEHICLE EQUIPMENT SPECIALISTS  
SALES-INSTALLATIONS-REPAIRS

**KEVIN GOOD**  
Government Sales

kgood@majorpolicesupply.com  
Tel: (973) 584-7714  
Fax: (973) 584-5022  
Cell: (202) 875-4042  
47 N. Dell Avenue • Kenil, NJ 07847

**Lendel Parkins**  
Vice-President

lendelparkins@comcast.net  
lendel@WVSL.PAOL.COM

West Virginia Signal & Light, Inc.

P.O. Box 134  
247 Kentuck Road  
Kenna, WV 25248

Ph. 304-372-9648  
Fx. 304-372-9684  
Cell 304-532-0583

**Andrew Predzimirski**  
DOT Sales Manager  
apredzimirski@whelen.com  
(860) 395-8716

Whelen Engineering  
whelen.com  
U.S.A.

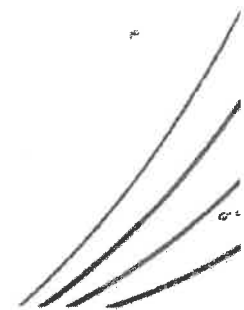



VANCE FITZSIMMONS

304-786-1512

SALES MAN

**ADDENDUM ACKNOWLEDGEMENT FORM**  
**SOLICITATION NO.: CRFO DOT2100000123**

**Instructions:** Please acknowledge receipt of all addenda issued with this solicitation by completing this addendum acknowledgment form. Check the box next to each addendum received and sign below. Failure to acknowledge addenda may result in bid disqualification.

**Acknowledgment:** I hereby acknowledge receipt of the following addenda and have made the necessary revisions to my proposal, plans and/or specification, etc.

**Addendum Numbers Received:**

(Check the box next to each addendum received)

- |  |  |
|--|--|
| <input checked="" type="checkbox"/> Addendum No. 1 | <input type="checkbox"/> Addendum No. 6  |
| <input type="checkbox"/> Addendum No. 2            | <input type="checkbox"/> Addendum No. 7  |
| <input type="checkbox"/> Addendum No. 3            | <input type="checkbox"/> Addendum No. 8  |
| <input type="checkbox"/> Addendum No. 4            | <input type="checkbox"/> Addendum No. 9  |
| <input type="checkbox"/> Addendum No. 5            | <input type="checkbox"/> Addendum No. 10 |

I understand that failure to confirm the receipt of addenda may be cause for rejection of this bid. I further understand that that any verbal representation made or assumed to be made during any oral discussion held between Vendor's representatives and any state personnel is not binding. Only the information issued in writing and added to the specifications by an official addendum is binding.

General Sales Administration, Inc. t/a Major Police Supply

\_\_\_\_\_  
Company

\_\_\_\_\_  
Authorized Signature

4/28/21  
\_\_\_\_\_  
Date

NOTE: This addendum acknowledgment should be submitted with the bid to expedite document processing.



Department of Administration  
 Purchasing Division  
 2019 Washington Street East  
 Post Office Box 50130  
 Charleston, WV 25305-0130

**State of West Virginia  
 Centralized Request for Quote  
 Public Safety**

<b>Proc Folder:</b> 843503		<b>Reason for Modification:</b>	
<b>Doc Description:</b> WHELEN LIGHTING PRODUCTS OR EQUAL			
<b>Proc Type:</b> Central Master Agreement			
<b>Date Issued</b>	<b>Solicitation Closes</b>	<b>Solicitation No</b>	<b>Version</b>
2021-04-01	2021-05-04 13:30	CRFQ 0803 DOT2100000123	1

**BID RECEIVING LOCATION**

BID CLERK  
 DEPARTMENT OF ADMINISTRATION  
 PURCHASING DIVISION  
 2019 WASHINGTON ST E  
 CHARLESTON WV 25305  
 US

**VENDOR**

**Vendor Customer Code:**  
**Vendor Name :** General Sales Administration, Inc. t/a Major Police Supply  
**Address :** 47 N. Dell Avenue  
**Street :**  
**City :** Kenvil  
**State :** New Jersey **Country :** USA **Zip :** 07847  
**Principal Contact :** Gregg Glenn  
**Vendor Contact Phone:** 410-627-1187 **Extension:**

**FOR INFORMATION CONTACT THE BUYER**

John W Estep  
 304-558-2566  
 john.w.estep@wv.gov

Vendor  
 Signature X

FEIN# 22-3004242

DATE

4/27/21

All offers subject to all terms and conditions contained in this solicitation

**ADDITIONAL INFORMATION****REQUEST FOR QUOTATION :**

The West Virginia Purchasing Division is soliciting bids on behalf of the West Virginia Division of Highways, Department of Transportation Equipment Division to establish an open-end contract for Whelen lighting products or equal. Per the Bid Requirements, Specifications, Terms and Conditions attached to this Solicitation.

INVOICE TO	SHIP TO
DIVISION OF HIGHWAYS EQUIPMENT DIVISION RT 33 83 BRUSHY ROAD CROSSING, PO BOX 610 BUCKHANNON WV 26201 US	DIVISION OF HIGHWAYS EQUIPMENT DIVISION 83 BRUSHY FORK RD CROSSING BUCKHANNON WV 26201 US

Line	Comm Ln Desc	Qty	Unit Issue	Unit Price	Total Price
1	Strobe or warning lights	0.00000	EA		

Comm Code	Manufacturer	Specification	Model #
39111706			

**Extended Description:**

Strobe or warning lights

**SCHEDULE OF EVENTS**

<u>Line</u>	<u>Event</u>	<u>Event Date</u>
1	Prebid Meeting - Equip Div Conf Room @ 10:00am	2021-04-21
2	Tech Questions due by 10:00am	2021-04-28

	Document Phase	Document Description	Page
DOT2100000123	Final	WHELEN LIGHTING PRODUCTS OR EQUAL	3

**ADDITIONAL TERMS AND CONDITIONS**

See attached document(s) for additional Terms and Conditions

## INSTRUCTIONS TO VENDORS SUBMITTING BIDS

**1. REVIEW DOCUMENTS THOROUGHLY:** The attached documents contain a solicitation for bids. Please read these instructions and all documents attached in their entirety. These instructions provide critical information about requirements that if overlooked could lead to disqualification of a Vendor's bid. All bids must be submitted in accordance with the provisions contained in these instructions and the Solicitation. Failure to do so may result in disqualification of Vendor's bid.

**2. MANDATORY TERMS:** The Solicitation may contain mandatory provisions identified by the use of the words "must," "will," and "shall." Failure to comply with a mandatory term in the Solicitation will result in bid disqualification.

**3. PREBID MEETING:** The item identified below shall apply to this Solicitation.

A pre-bid meeting will not be held prior to bid opening

A **MANDATORY PRE-BID** meeting will be held at the following place and time:

WVDOH Equipment Division  
Equipment Division Conference Room  
83 Brushy Fork Rd. Crossing  
Buckhannon, WV 26201  
April 21, 2021 at 10:00am

All Vendors submitting a bid must attend the mandatory pre-bid meeting. Failure to attend the mandatory pre-bid meeting shall result in disqualification of the Vendor's bid. No one individual is permitted to represent more than one vendor at the pre-bid meeting. Any individual that does attempt to represent two or more vendors will be required to select one vendor to which the individual's attendance will be attributed. The vendors not selected will be deemed to have not attended the pre-bid meeting unless another individual attended on their behalf.

An attendance sheet provided at the pre-bid meeting shall serve as the official document verifying attendance. Any person attending the pre-bid meeting on behalf of a Vendor must list on the attendance sheet his or her name and the name of the Vendor he or she is representing.

Additionally, the person attending the pre-bid meeting should include the Vendor's E-Mail address, phone number, and Fax number on the attendance sheet. It is the Vendor's responsibility to locate the attendance sheet and provide the required information. Failure to complete the attendance sheet as required may result in disqualification of Vendor's bid.

All Vendors should arrive prior to the starting time for the pre-bid. Vendors who arrive after the starting time but prior to the end of the pre-bid will be permitted to sign in, but are charged with knowing all matters discussed at the pre-bid.

Questions submitted at least five business days prior to a scheduled pre-bid will be discussed at the pre-bid meeting if possible. Any discussions or answers to questions at the pre-bid meeting  
Revised 11/14/2019

are preliminary in nature and are non-binding. Official and binding answers to questions will be published in a written addendum to the Solicitation prior to bid opening.

**4. VENDOR QUESTION DEADLINE:** Vendors may submit questions relating to this Solicitation to the Purchasing Division. Questions must be submitted in writing. All questions must be submitted on or before the date listed below and to the address listed below in order to be considered. A written response will be published in a Solicitation addendum if a response is possible and appropriate. Non-written discussions, conversations, or questions and answers regarding this Solicitation are preliminary in nature and are nonbinding.

Submitted e-mails should have solicitation number in the subject line.

Question Submission Deadline: April 28, 2021 by 10:00am

Submit Questions to: John Estep  
2019 Washington Street, East  
Charleston, WV 25305  
Fax: (304) 558-4115 (Vendors should not use this fax number for bid submission)  
Email: john.w.estep@wv.gov

**5. VERBAL COMMUNICATION:** Any verbal communication between the Vendor and any State personnel is not binding, including verbal communication at the mandatory pre-bid conference. Only information issued in writing and added to the Solicitation by an official written addendum by the Purchasing Division is binding.

**6. BID SUBMISSION:** All bids must be submitted electronically through wvOASIS or signed and delivered by the Vendor to the Purchasing Division at the address listed below on or before the date and time of the bid opening. Any bid received by the Purchasing Division staff is considered to be in the possession of the Purchasing Division and will not be returned for any reason. The Purchasing Division will not accept bids, modification of bids, or addendum acknowledgment forms via e-mail. Acceptable delivery methods include electronic submission via wvOASIS, hand delivery, delivery by courier, or facsimile.

The bid delivery address is:  
Department of Administration, Purchasing Division  
2019 Washington Street East  
Charleston, WV 25305-0130

A bid that is not submitted electronically through wvOASIS should contain the information listed below on the face of the envelope or the bid may be rejected by the Purchasing Division.:

SEALED BID:	Whelen Lighting Products or Equal
BUYER:	John Estep
SOLICITATION NO.:	CRFQ 0803 DOT2100000123
BID OPENING DATE:	May 4, 2021
BID OPENING TIME:	1:30pm
FAX NUMBER:	304-558-3970

Revised 11/14/2019

The Purchasing Division may prohibit the submission of bids electronically through wvOASIS at its sole discretion. Such a prohibition will be contained and communicated in the wvOASIS system resulting in the Vendor's inability to submit bids through wvOASIS. Submission of a response to an Expression or Interest or Request for Proposal is not permitted in wvOASIS.

**For Request For Proposal ("RFP") Responses Only:** In the event that Vendor is responding to a request for proposal, the Vendor shall submit one original technical and one original cost proposal plus \_\_\_\_\_ convenience copies of each to the Purchasing Division at the address shown above. Additionally, the Vendor should identify the bid type as either a technical or cost proposal on the face of each bid envelope submitted in response to a request for proposal as follows:

BID TYPE: (This only applies to CRFP)

Technical

Cost

**7. BID OPENING:** Bids submitted in response to this Solicitation will be opened at the location identified below on the date and time listed below. Delivery of a bid after the bid opening date and time will result in bid disqualification. For purposes of this Solicitation, a bid is considered delivered when confirmation of delivery is provided by wvOASIS (in the case of electronic submission) or when the bid is time stamped by the official Purchasing Division time clock (in the case of hand delivery).

Bid Opening Date and Time: May 4, 2021 @ 1:30 pm

Bid Opening Location: Department of Administration, Purchasing Division  
2019 Washington Street East  
Charleston, WV 25305-0130

**8. ADDENDUM ACKNOWLEDGEMENT:** Changes or revisions to this Solicitation will be made by an official written addendum issued by the Purchasing Division. Vendor should acknowledge receipt of all addenda issued with this Solicitation by completing an Addendum Acknowledgment Form, a copy of which is included herewith. Failure to acknowledge addenda may result in bid disqualification. The addendum acknowledgement should be submitted with the bid to expedite document processing.

**9. BID FORMATTING:** Vendor should type or electronically enter the information onto its bid to prevent errors in the evaluation. Failure to type or electronically enter the information may result in bid disqualification.

**10. ALTERNATE MODEL OR BRAND:** Unless the box below is checked, any model, brand, or specification listed in this Solicitation establishes the acceptable level of quality only and is not intended to reflect a preference for, or in any way favor, a particular brand or vendor. Vendors may bid alternates to a listed model or brand provided that the alternate is at least equal to the model or brand and complies with the required specifications. The equality of any alternate being bid shall be determined by the State at its sole discretion. Any Vendor bidding an alternate model or brand should clearly identify the alternate items in its bid and should include manufacturer's specifications, industry literature, and/or any other relevant documentation demonstrating the



equality of the alternate items. Failure to provide information for alternate items may be grounds for rejection of a Vendor's bid.

This Solicitation is based upon a standardized commodity established under W. Va. Code § 5A-3-61. Vendors are expected to bid the standardized commodity identified. Failure to bid the standardized commodity will result in your firm's bid being rejected.

**11. EXCEPTIONS AND CLARIFICATIONS:** The Solicitation contains the specifications that shall form the basis of a contractual agreement. Vendor shall clearly mark any exceptions, clarifications, or other proposed modifications in its bid. Exceptions to, clarifications of, or modifications of a requirement or term and condition of the Solicitation may result in bid disqualification.

**12. COMMUNICATION LIMITATIONS:** In accordance with West Virginia Code of State Rules §148-1-6.6, communication with the State of West Virginia or any of its employees regarding this Solicitation during the solicitation, bid, evaluation or award periods, except through the Purchasing Division, is strictly prohibited without prior Purchasing Division approval. Purchasing Division approval for such communication is implied for all agency delegated and exempt purchases.

**13. REGISTRATION:** Prior to Contract award, the apparent successful Vendor must be properly registered with the West Virginia Purchasing Division and must have paid the \$125 fee, if applicable.

**14. UNIT PRICE:** Unit prices shall prevail in cases of a discrepancy in the Vendor's bid.

**15. PREFERENCE:** Vendor Preference may be requested in purchases of motor vehicles or construction and maintenance equipment and machinery used in highway and other infrastructure projects. Any request for preference must be submitted in writing with the bid, must specifically identify the preference requested with reference to the applicable subsection of West Virginia Code § 5A-3-37, and should include with the bid any information necessary to evaluate and confirm the applicability of the requested preference. A request form to help facilitate the request can be found at:

<http://www.state.wv.us/admin/purchase/vrc/Venpref.pdf>.

**15A. RECIPROCAL PREFERENCE:** The State of West Virginia applies a reciprocal preference to all solicitations for commodities and printing in accordance with W. Va. Code § 5A-3-37(b). In effect, non-resident vendors receiving a preference in their home states, will see that same preference granted to West Virginia resident vendors bidding against them in West Virginia. A request form to help facilitate the request can be found at:

<http://www.state.wv.us/admin/purchase/vrc/Venpref.pdf>.

**16. SMALL, WOMEN-OWNED, OR MINORITY-OWNED BUSINESSES:** For any solicitations publicly advertised for bid, in accordance with West Virginia Code §5A-3-37(a)(7) and W. Va. CSR § 148-22-9, any non-resident vendor certified as a small, women-owned, or minority-owned business under W. Va. CSR § 148-22-9 shall be provided the same preference made available to any resident vendor. Any non-resident small, women-owned, or minority-owned business must identify itself as such in writing, must submit that writing to the

Purchasing Division with its bid, and must be properly certified under W. Va. CSR § 148-22-9 prior to contract award to receive the preferences made available to resident vendors. Preference for a non-resident small, women-owned, or minority owned business shall be applied in accordance with W. Va. CSR § 148-22-9.

**17. WAIVER OF MINOR IRREGULARITIES:** The Director reserves the right to waive minor irregularities in bids or specifications in accordance with West Virginia Code of State Rules § 148-1-4.6.

**18. ELECTRONIC FILE ACCESS RESTRICTIONS:** Vendor must ensure that its submission in wvOASIS can be accessed and viewed by the Purchasing Division staff immediately upon bid opening. The Purchasing Division will consider any file that cannot be immediately accessed and viewed at the time of the bid opening (such as, encrypted files, password protected files, or incompatible files) to be blank or incomplete as context requires, and are therefore unacceptable. A vendor will not be permitted to unencrypt files, remove password protections, or resubmit documents after bid opening to make a file viewable if those documents are required with the bid. A Vendor may be required to provide document passwords or remove access restrictions to allow the Purchasing Division to print or electronically save documents provided that those documents are viewable by the Purchasing Division prior to obtaining the password or removing the access restriction.

**19. NON-RESPONSIBLE:** The Purchasing Division Director reserves the right to reject the bid of any vendor as Non-Responsible in accordance with W. Va. Code of State Rules § 148-1-5.3, when the Director determines that the vendor submitting the bid does not have the capability to fully perform, or lacks the integrity and reliability to assure good-faith performance.”

**20. ACCEPTANCE/REJECTION:** The State may accept or reject any bid in whole, or in part in accordance with W. Va. Code of State Rules § 148-1-4.5. and § 148-1-6.4.b.”

**21. YOUR SUBMISSION IS A PUBLIC DOCUMENT:** Vendor’s entire response to the Solicitation and the resulting Contract are public documents. As public documents, they will be disclosed to the public following the bid/proposal opening or award of the contract, as required by the competitive bidding laws of West Virginia Code §§ 5A-3-1 et seq., 5-22-1 et seq., and 5G-1-1 et seq. and the Freedom of Information Act West Virginia Code §§ 29B-1-1 et seq.

**DO NOT SUBMIT MATERIAL YOU CONSIDER TO BE CONFIDENTIAL, A TRADE SECRET, OR OTHERWISE NOT SUBJECT TO PUBLIC DISCLOSURE.**

Submission of any bid, proposal, or other document to the Purchasing Division constitutes your explicit consent to the subsequent public disclosure of the bid, proposal, or document. The Purchasing Division will disclose any document labeled “confidential,” “proprietary,” “trade secret,” “private,” or labeled with any other claim against public disclosure of the documents, to include any “trade secrets” as defined by West Virginia Code § 47-22-1 et seq. All submissions are subject to public disclosure without notice.

**22. INTERESTED PARTY DISCLOSURE:** West Virginia Code § 6D-1-2 requires that the vendor submit to the Purchasing Division a disclosure of interested parties to the contract for all contracts with an actual or estimated value of at least \$1 Million. That disclosure must occur on the form prescribed and approved by the WV Ethics Commission prior to contract award. A copy of that form is included with this solicitation or can be obtained from the WV Ethics Commission. This requirement does not apply to publicly traded companies listed on a national or international stock exchange. A more detailed definition of interested parties can be obtained from the form referenced above.

**23. WITH THE BID REQUIREMENTS:** In instances where these specifications require documentation or other information with the bid, and a vendor fails to provide it with the bid, the Director of the Purchasing Division reserves the right to request those items after bid opening and prior to contract award pursuant to the authority to waive minor irregularities in bids or specifications under W. Va. CSR § 148-1-4.6. This authority does not apply to instances where state law mandates receipt with the bid.

REQUEST FOR QUOTATION  
Whelen lighting products or equal

---

SPECIFICATIONS

1. **PURPOSE AND SCOPE:** The West Virginia Purchasing Division is soliciting bids on behalf of the West Virginia Division of Highways, Department of Transportation Equipment Division to establish an open-end contract for Whelen lighting products or equal.
  
2. **DEFINITIONS:** The terms listed below shall have the meanings assigned to them below. Additional definitions can be found in section 2 of the General Terms and Conditions.
  - 2.1 **“Contract Item” or “Contract Items”** means the list of items identified in Section 3, Subsection 1 below.
  - 2.2 **“Pricing Pages”** means the schedule of prices, estimated order quantity, and totals contained in wvOASIS or attached hereto as Exhibit A and used to evaluate the Solicitation responses.
  - 2.3 **“Solicitation”** means the official notice of an opportunity to supply the State with goods or services that is published by the Purchasing Division.
  - 2.4 **“WVDOH”** means West Virginia Division of Highways.
  - 2.5 **“PSI”** means an abbreviation Pounds per square inch.
  - 2.6 **“Total Bid Price”** means the sum of the bid total column.
  - 2.7 **“GVWR”** means gross vehicle weight rating.
  - 2.8 **“±”** means plus or minus.
  - 2.9 **“MM”** means Millimeter
  - 2.10 **“SAE”** means Society of automotive engineers.
  - 2.11 **“LED”** means light-emitting diode.
  - 2.12 **“SAE J845”** Refers to omnidirectional or 360-degree optical warning lights. <https://www.safetylightsandsignals.com/p-1167-what-is-the-difference-between-sae-class-1-sae-class-2-and-sae-class-3-warning-lights.aspx>
  - 2.13 **“ITL3”** means Two takedown lights.

REQUEST FOR QUOTATION  
Whelen lighting products or equal

---

2.14 "IWDLA" means 1 long amber single-color light head.

2.15 "IWDSA" means 1 short amber single-color light head.

2.16 "IA3" means two alley lights.

2.17 "IXPHOTO" means photocell.

**3. GENERAL REQUIREMENTS:**

**3.1 Contract Items and Mandatory Requirements:** Vendor shall provide Agency with the Contract Items listed below on an open-end and continuing basis. Contract items must meet or exceed the mandatory requirements as shown below.

**3.1.1 General**

3.1.1.1 The unit specified herein and offered shall be manufactured on or after January 1, 2021 and will be clearly identified and marked with date of manufacture.

3.1.1.2 Vendor shall provide a product pricing sheet with bid.

3.1.1.3 Light bars shall use Hard-coated lenses. Hard coating shall be a separate process of clear coating applied to a poly lens.

3.1.1.4 Light bars that use clips to hold the dome cover in place shall not be accepted.

3.1.1.5 Prototypes and demonstrator models will not be accepted.

3.1.1.6 The 24-month warranty shall also include 48-hour factory turnaround repair service.

3.1.1.7 Operating voltage shall be 10 to 16-volt DC.

3.1.1.8 Module shall be solid state with built in reverse polarity protection.

**REQUEST FOR QUOTATION**  
**Whelen lighting products or equal**

---

- 3.1.1.9 Shall be SAE Class 1 and California title XIII certified.
- 3.1.1.10 Color(S) displayed by bar light shall be picked when order is placed.
- 3.1.1.11 LED's shall be permanently mounted within a single removable parabolic reflector.
- 3.1.1.12 Halogen or incandescent bulbs shall not be accepted.

**3.1.2 Liberty II Lightbar OR Equal**

- 3.1.2.1 Lightbar thickness shall be 2.8 inches tall by 11 3/8 inches wide. ± one half inch not including mounting feet.
- 3.1.2.2 Lightbar lengths bid shall be 44 inches, 48 inches and 54 inches. ± one inch.
- 3.1.2.3 Top of light shall have an aluminum cover secured by a minimum of 4 screws.
- 3.1.2.4 Bars 44 inches shall have a minimum 114 LED count and contain one ITL3 or equal take-down module, six IWDLA or equal long amber flasher module, one IA3 or equal alley light module, one IXPHOTO or equal photo cell module and four IWDSA or equal short amber flasher module
- 3.1.2.5 Bars 48 inches shall have a minimum 120 LED count and contain one ITL3 or equal take down light module, ten IWDLA or equal long amber flasher module, one IA3 or equal alley light module and one IXPHOTO or equal photocell module.
- 3.1.2.6 Bars 54 inches shall have a minimum 132 LED count and contain one ITL3 or equal take down light module, ten IWDLA or equal long amber flasher module, four IWDSA or equal short amber flasher, one IA3 or equal alley light module and one IXPHOTO or equal photocell module.
- 3.1.2.7 Lens shall be clear.
- 3.1.2.8 Seals shall be injection molded.
- 3.1.2.9 Shall have 360-degree light projection.

**REQUEST FOR QUOTATION**  
**Whelen lighting products or equal**

---

- 3.1.2.10 Shall be a minimum 12 diode linear-LED corners
- 3.1.2.11 Shall have point to point wiring between the I/O board and each light head.
- 3.1.2.12 Shall have a 2 conductor 8-gauge power and ground minimum of 17 feet in length passenger side exit cable.
- 3.1.2.13 Shall have 17 conductor 22-gauge control cable passenger side exit minimum 17 feet in length.
- 3.1.2.14 Shall have a photocell to automatically switch lightbar to low power mode for night operation for night safety.
- 3.1.2.15 Standard mounting kit included shall include a combination permanent mount and gutter mount. Gutter straps must be compatible with late model vehicles including Dodge, Ford, and GM pickup trucks.
- 3.1.2.16 Shall have a minimum 24-month parts and labor warranty. LED's shall have a warranty period of 5 years.

**3.1.3 ION T WHITE 5.2 INCH OR EQUAL**

- 3.1.3.1 Illuminated color shall be white.
- 3.1.3.2 Lenses shall be hard-coated.
- 3.1.3.3 Surface mounting shall use a maximum of two screws.
- 3.1.3.4 Light bezel shall be black.
- 3.1.3.5 Light shall have a 4-wire pigtail 6 inches in length.
- 3.1.3.6 Shall be a maximum of 5.2 inches in length  $\pm$  one half inch
- 3.1.3.7 Shall be a maximum width of 1.5 inches  $\pm$  one eighth inch
- 3.1.3.8 Shall be 1/2 thick from base of mounting flange to face of light.  $\pm$  one eighth inch
- 3.1.3.9 Shall have a minimum 5-year warranty.

**REQUEST FOR QUOTATION**  
**Whelen lighting products or equal**

---

**3.1.4 MINI T WHITE 3.9 INCH OR EQUAL.**

- 3.1.4.1 Lenses shall be hard-coated.
- 3.1.4.2 Surface mounting shall use a maximum of two screws.
- 3.1.4.3 Light bezel shall be black.
- 3.1.4.4 Light shall have a 4-wire pigtail 6 inches in length.
- 3.1.4.5 Shall be a maximum of 3.9 inches in length  $\pm$  one half inch
- 3.1.4.6 Shall be a maximum width of 1.5 inches  $\pm$  one eighth inch
- 3.1.4.7 Shall be one half inch thick from base of mounting flange to face of light.  $\pm$  one eighth inch
- 3.1.4.8 Illuminated color shall be white.
- 3.1.4.9 Shall be a minimum 5-year warranty.

**3.1.5 ION T AMBER 5.2 INCH OR EQUAL**

- 3.1.5.1 Illuminated color shall be Amber.
- 3.1.5.2 Lenses shall be hard-coated.
- 3.1.5.3 Surface mounting shall use a maximum of two screws.
- 3.1.5.4 Light bezel shall be black.
- 3.1.5.5 Light shall have a 4-wire pigtail 6 inches in length.
- 3.1.5.6 Shall be a maximum of 5.2 inches in length  $\pm$  one half inch
- 3.1.5.7 Shall be a maximum width of 1.5 inches  $\pm$  one eighth inch
- 3.1.5.8 Shall be one half thick from base of mounting flange to face of light.  $\pm$  one eighth inch
- 3.1.5.9 Shall have a minimum 5-year warranty.



REQUEST FOR QUOTATION  
Whelen lighting products or equal

---

**3.1.6 MINI T AMBER 3.9 INCH OR EQUAL.**

- 3.1.6.1 Lenses shall be hard-coated.
- 3.1.6.2 Surface mounting shall use a maximum of two screws.
- 3.1.6.3 Light bezel shall be black.
- 3.1.6.4 Light shall have a 4-wire pigtail 6 inches in length.
- 3.1.6.5 Shall be a maximum of 3.9 inches in length  $\pm$  one half inch
- 3.1.6.6 Shall be a maximum width of 1.5 inches  $\pm$  one eighth inch
- 3.1.6.7 Shall be one half inch thick from base of mounting flange to face of light.  $\pm$  one half inch
- 3.1.6.8 Illuminated color shall be Amber.
- 3.1.6.9 Shall be a minimum 5-year warranty.

**3.1.7 Warranty:**

- 3.1.7.1 The 24-month warranty shall also include 48-hour factory turnaround repair service.
- 3.1.7.3 Shall have a minimum 24-month parts and labor warranty. LED's shall have a warranty period of 5 years.

**4. CONTRACT AWARD, PRICING PAGES, DISCOUNT/MARKUP PERCENTAGE:**

- 4.1 **Contract Award:** The Contract is intended to provide Agency with a purchase price on all Contract Items. The Contract shall be awarded to the Vendor that provides the Contract Items meeting the required specifications for the lowest overall Total Bid Cost as shown on the Pricing Pages.
- 4.2 **Discount Percentage:** Vendor may quote a single Discount Percentage that will reduce the lowest price shown in the Catalog for every Contract Item. The resulting Adjusted Unit Price shall be the price Agency pay for purchases of that Contract Item under this Contract.

REQUEST FOR QUOTATION  
Whelen lighting products or equal

---

Vendor shall not incorporate Discount Percentages into its Catalog unless the Vendor clearly shows the Catalog Price and then separately lists the applicable Discount Percentage and the Adjusted Unit Price for each Contract Item.

The Discount Percentage and subsequent Adjusted Unit Price derived from that discount must consider all fees, charges, or other miscellaneous costs that the Vendor may require, including delivery charges as indicated below, because those fees, charges, or other miscellaneous costs will not be paid separately. The Agency shall only pay the appropriate Adjusted Unit Price for items purchased under this Contract.

- 4.3 Markup Percentage:** Vendor may quote a single Markup Percentage that will increase the lowest price shown in the Catalog for every Contract Item. The resulting Adjusted Unit Price shall be the price Agency pay for purchases of that Contract Item under this Contract.

Vendor shall not incorporate Markup Percentages into its Catalog unless the Vendor clearly shows the Catalog Price and then separately lists the applicable Markup Percentage and the Adjusted Unit Price for each Contract Item.

The Markup Percentage and subsequent Adjusted Unit Price derived from that markup must consider all fees, charges, or other miscellaneous costs that the Vendor may require, including delivery charges as indicated below, because those fees, charges, or other miscellaneous costs will not be paid separately. The Agency shall only pay the appropriate Adjusted Unit Price for items purchased under this Contract.

Vendor shall only quote a Discount Percentage or a Markup Percentage per Solicitation. If a solicitation response contains both a Discount Percentage and a Markup Percentage for the same bid response, the bid response will be disqualified.

- 4.4 Pricing Pages:** Vendor shall complete the Pricing Pages (Exhibit A) by inserting either a Discount Percentage or a Markup Percentage. Vendor should insert the Catalog Unit Price from Vendor's current catalog for each of the items listed. **Vendor's bidding an "or Equal" product line must reference their part number for each of the "OEM" part numbers as they coincide on the Pricing Pages.** Vendor should complete the Pricing Pages in their entirety as failure to do so may result in Vendor's bids being disqualified.

REQUEST FOR QUOTATION  
Whelen lighting products or equal

---

The Pricing Pages contain a list of the Contract Items and estimated purchase volume. All Contract Items contained on the Pricing Pages shall be bid as "NEW". Rebuilt or reconditioned pricing will not be accepted for bidding purposes. The estimated purchase volume for each item represents the approximate volume of anticipated purchases only. No future use of the Contract or any individual item is guaranteed or implied.

Vendors are **strongly encouraged** to complete the Pricing Pages through WVOasis or electronically in Microsoft Excel. Doing so will reduce the number of, and the possibility for calculation errors. The Pricing Pages were created as a Microsoft Excel document and Vendor can request an electronic copy for bid purposes by sending an email request to the following address: [John.W.Estep@wv.gov](mailto:John.W.Estep@wv.gov)

The Purchasing Division reserves the right to take Vendor's Pricing Pages and insert the appropriate numbers into the Microsoft Excel spreadsheet if Vendor chooses to complete the Pricing Pages in any other way.

**PLEASE READ THIS SECTION IN IT'S ENTIRETY IF VENDOR IS SUBMITTING AN ELECTRONIC BID:**

*Vendor MUST complete the ATTACHED Pricing Page, Exhibit A. If bidding electronically, Vendor is to put \$0.00 on the commodity line in WVOasis, complete the Excel pricing page, and upload into WVOasis as an attachment. Only pricing submitted via Exhibit A pricing page will be evaluated for award.*

**5. ORDERING AND PAYMENT:**

**5.1 Ordering:** Vendor shall accept orders through wvOASIS, regular mail, facsimile, e-mail, or any other written forms of communication. Vendor may but is not required to accept on-line orders through a secure internet ordering portal/website. If Vendor has the ability to accept on-line orders, it should include in its response a brief description of how Agencies may utilize the on-line ordering system. Vendor shall ensure that its on-line ordering system is properly secured prior to processing Agency orders on-line.

**5.2 Payment:** Vendor shall accept payment in accordance with the payment procedures of the State of West Virginia.

**6. DELIVERY AND RETURN:**

**6.1 Delivery Time:** A completed pilot model for inspection must be provided within 20 working day(s) after receipt of the pilot model order, by the successful vendor.

**REQUEST FOR QUOTATION**  
**Whelen lighting products or equal**

---

Vendor shall deliver standard orders within 30 working days after orders are received. Working day is defined as any weekday, Monday thru Friday, excluding Federal and State Holidays. Vendor shall ship all orders until a minimum delivery quantity is met. Contract items must be delivered to the ordering Agency WVDOH, Equipment Division located at 83 Brushy Fork Road Crossing, Buckhannon, West Virginia 26201

- 6.2 Late Delivery:** The Agency placing the order under this Contract must be notified in writing if orders will be delayed for any reason. Any delay in delivery that could cause harm to an Agency will be grounds for cancellation of the delayed order, and/or obtaining the items ordered from a third party.

Any Agency seeking to obtain items from a third party under this provision must first obtain approval of the Purchasing Division.

- 6.3 Delivery Payment/Risk of Loss:** Standard order delivery shall be F.O.B. Destination to the Agency's location. Vendor shall include the cost of standard order delivery charges in its bid pricing/discount and is not permitted to charge the Agency separately for such delivery. The Agency will pay delivery charges on all emergency orders provided that Vendor invoices those delivery costs as a separate charge with the original freight bill attached to the invoice.

- 6.4 Condition of Unit(s) Upon Delivery:** All units must arrive at the prescribed delivery point having been completely pre-serviced with oil, lubricants, and coolant. All prescribed precautions pertaining to first operations and break-in of the unit are to be posted conspicuously on the unit for ready observance by the operator.

- 6.5 Delivery Point:** Delivery point of the completed representative unit will be the WVDOH, Equipment Division, 83 Brushy Fork Road Crossing, Buckhannon, WV 26201.

**7. VENDOR DEFAULT:**

- 7.1** The following shall be considered a vendor default under this Contract.

**7.1.1** Failure to provide Contract Items in accordance with the requirements contained herein.

**7.1.2** Failure to comply with other specifications and requirements contained herein.

**7.1.3** Failure to comply with any laws, rules, and ordinances applicable to the Contract Services provided under this Contract.

**REQUEST FOR QUOTATION**  
**Whelen lighting products or equal**

---

7.1.4 Failure to remedy deficient performance upon request.

7.2 The following remedy shall be available to Agency upon default.

7.2.1 Immediate cancellation of the contract.

7.2.2 Immediate cancellation of one or more release orders issued under this Contract.

7.2.3 Any other remedies available in law or equity.

**8. MISCELLANEOUS:**

**8.1 No Substitutions:** Vendor shall supply only Contract Items submitted in response to the Solicitation unless a contract modification is approved in accordance with the provisions contained in this Contract.

**8.2 Reports:** Vendor shall provide quarterly reports and annual summaries to the Agency showing the Agency's items purchased, quantities of items purchased, and total dollar value of the items purchased. Vendor shall also provide reports, upon request, showing the items purchased during the term of this Contract, the quantity purchased for each of those items, and the total value of purchases for each of those items. Failure to supply such reports may be grounds for cancellation of this Contract.

**8.3 Contract Manager:** During its performance of this Contract, Vendor must designate and maintain a primary contract manager responsible for overseeing Vendor's responsibilities under this Contract. The Contract manager must be available during normal business hours to address any customer service or other issues related to this Contract. Vendor should list its Contract manager and his or her contact information below.

**Contract Manager:** Gregg Glenn  
**Telephone Number:** 410-627-1187  
**Fax Number:** 973-584-5022  
**Email Address:** gglenn@majorpolicesupply.com

**VENDOR: General Sales Administration, Inc. t/a Major Police Supply Whelen Lighting products or EQUAL - Pricing Page**

Discount Percentage\*\*                      -55.80% (Please enter as a negative. Example discount of 5% should be -5.0%)  
 Markup Percentage\*\*                      0.00%

Item No.	OEM Part number	"Or Equal" Parts	Estimated Unit Quantity	Unit (for calculation purposes)	Catalog Unit Price	Units Provided for Catalog Price	**Discount/Markup** Percentage	Adjusted Unit Price	Item Total Cost
1	Part No. IX4AAAA Description: 44" Whelen Liberty II or equal	Part No. FN-4420 Description: FENIEX FUSION GPL 44" WITH HOOK MOUNT	100	EACH	\$ 1,698.30	1.00	-55.80%	\$ 750.65	\$75,065.00
2	Part No. IX8AAAA Description: 48" Whelen Liberty II or equal	Part No. FN-4918 Description: FENIEX FUSION GPL 49" WITH HOOK MOUNT	100	EACH	\$ 1,868.30	1.00	-55.80%	\$ 825.79	\$82,579.00
3	Part No. IX2AAAA Description: 54" Whelen Liberty II or equal	Part No. FN-6019 Description: FENIEX FUSION GPL 60" WITH HOOK MOUNT	100	EACH	\$ 2,038.30	1.00	-55.80%	\$ 900.93	\$90,093.00
4	Part No. TLIC Description: ION T 5.2" or equal white in color	Part No. FSM-W Description: FUSION SURFACE MOUNT WHITE	50	EACH	\$ 83.30	1.00	-55.80%	\$ 36.82	\$1,841.00
5	Part No. TLIA Description: ION T 5.2" or equal amber in color	Part No. FSM-A Description: FUSION SURFACE MOUNT AMBER	50	EACH	\$ 83.30	1.00	-55.80%	\$ 36.82	\$1,841.00
6	Part No. TLMIC Description: Mini T 3.9" or equal white in color	Part No. D50015-W Description: TIR 3 SURFACE MOUNT WHITE	50	EACH	\$ 49.30	1.00	-55.80%	\$ 21.79	\$1,089.50
7	Part No. TLMIA Description: Mini T 3.9" or equal amber in color	Part No. D50015-A Description: TIR 3 SURFACE MOUNT AMBER	50	EACH	\$ 49.30	1.00	-55.80%	\$ 21.79	\$1,089.50
<b>Total Bid Cost</b>									<b>\$253,598.00</b>

CONTRACT MANAGER: Gregg Glenn

TELEPHONE NUMBER: 410-627-1187

FAX NUMBER: 973-584-5022

E-MAIL ADDRESS: rglenn@majorpolicesupply.com

## West Virginia Ethics Commission



### Disclosure of Interested Parties to Contracts

Pursuant to *W. Va. Code* § 6D-1-2, a state agency may not enter into a contract, or a series of related contracts, that has/have an actual or estimated value of \$1 million or more until the business entity submits to the contracting state agency a Disclosure of Interested Parties to the applicable contract. In addition, the business entity awarded a contract is obligated to submit a supplemental Disclosure of Interested Parties reflecting any new or differing interested parties to the contract within 30 days following the completion or termination of the applicable contract.

For purposes of complying with these requirements, the following definitions apply:

*"Business entity"* means any entity recognized by law through which business is conducted, including a sole proprietorship, partnership or corporation, but does not include publicly traded companies listed on a national or international stock exchange.

*"Interested party"* or *"Interested parties"* means:

- (1) A business entity performing work or service pursuant to, or in furtherance of, the applicable contract, including specifically sub-contractors;
- (2) the person(s) who have an ownership interest equal to or greater than 25% in the business entity performing work or service pursuant to, or in furtherance of, the applicable contract. (This subdivision does not apply to a publicly traded company); and
- (3) the person or business entity, if any, that served as a compensated broker or intermediary to actively facilitate the applicable contract or negotiated the terms of the applicable contract with the state agency. (This subdivision does not apply to persons or business entities performing legal services related to the negotiation or drafting of the applicable contract.)

*"State agency"* means a board, commission, office, department or other agency in the executive, judicial or legislative branch of state government, including publicly funded institutions of higher education: Provided, that for purposes of *W. Va. Code* § 6D-1-2, the West Virginia Investment Management Board shall not be deemed a state agency nor subject to the requirements of that provision.

The contracting business entity must complete this form and submit it to the contracting state agency prior to contract award and to complete another form within 30 days of contract completion or termination.

*This form was created by the State of West Virginia Ethics Commission, 210 Brooks Street, Suite 300, Charleston, WV 25301-1804. Telephone: (304)558-0664; fax: (304)558-2169; e-mail: [ethics@wv.gov](mailto:ethics@wv.gov); website: [www.ethics.wv.gov](http://www.ethics.wv.gov).*

West Virginia Ethics Commission  
**Disclosure of Interested Parties to Contracts**

(Required by *W. Va. Code* § 6D-1-2)

Name of Contracting Business Entity: General Sales Administration, Inc Address: 47 N. Dell Avenue  
t/a Major Police Supply Kenvil, NJ 07847

Name of Authorized Agent: J. Bradley Badal Address: 108 Mountainside Rd., Mendham, NJ 07945

Contract Number: CRFQ 0803 DOT2100000123 Contract Description: WHELEN LIGHTING PRODUCTS OR EQUAL

Governmental agency awarding contract: WEST VIRGINIA PURCHASING DIVISION

Check here if this is a Supplemental Disclosure

List the Names of Interested Parties to the contract which are known or reasonably anticipated by the contracting business entity for each category below (*attach additional pages if necessary*):

**1. Subcontractors or other entities performing work or service under the Contract**

Check here if none, otherwise list entity/individual names below.

**2. Any person or entity who owns 25% or more of contracting entity (not applicable to publicly traded entities)**

Check here if none, otherwise list entity/individual names below.

**3. Any person or entity that facilitated, or negotiated the terms of, the applicable contract (excluding legal services related to the negotiation or drafting of the applicable contract)**

Check here if none, otherwise list entity/individual names below.

Signature: 

Date Signed: 4/26/21

**Notary Verification**

State of NEW JERSEY, County of MORRIS:

I, J. Bradley Badal, the authorized agent of the contracting business entity listed above, being duly sworn, acknowledge that the Disclosure herein is being made under oath and under the penalty of perjury.

Taken, sworn to and subscribed before me this 26 day of April, 2021



  
Notary Public's Signature

**To be completed by State Agency:**

Date Received by State Agency: \_\_\_\_\_

Date submitted to Ethics Commission: \_\_\_\_\_

Governmental agency submitting Disclosure: \_\_\_\_\_



STATE OF WEST VIRGINIA  
Purchasing Division

# PURCHASING AFFIDAVIT

**CONSTRUCTION CONTRACTS:** Under W. Va. Code § 5-22-1(i), the contracting public entity shall not award a construction contract to any bidder that is known to be in default on any monetary obligation owed to the state or a political subdivision of the state, including, but not limited to, obligations related to payroll taxes, property taxes, sales and use taxes, fire service fees, or other fines or fees.

**ALL CONTRACTS:** Under W. Va. Code §5A-3-10a, no contract or renewal of any contract may be awarded by the state or any of its political subdivisions to any vendor or prospective vendor when the vendor or prospective vendor or a related party to the vendor or prospective vendor is a debtor and: (1) the debt owed is an amount greater than one thousand dollars in the aggregate; or (2) the debtor is in employer default.

**EXCEPTION:** The prohibition listed above does not apply where a vendor has contested any tax administered pursuant to chapter eleven of the W. Va. Code, workers' compensation premium, permit fee or environmental fee or assessment and the matter has not become final or where the vendor has entered into a payment plan or agreement and the vendor is not in default of any of the provisions of such plan or agreement.

**DEFINITIONS:**

**"Debt"** means any assessment, premium, penalty, fine, tax or other amount of money owed to the state or any of its political subdivisions because of a judgment, fine, permit violation, license assessment, defaulted workers' compensation premium, penalty or other assessment presently delinquent or due and required to be paid to the state or any of its political subdivisions, including any interest or additional penalties accrued thereon.

**"Employer default"** means having an outstanding balance or liability to the old fund or to the uninsured employers' fund or being in policy default, as defined in W. Va. Code § 23-2c-2, failure to maintain mandatory workers' compensation coverage, or failure to fully meet its obligations as a workers' compensation self-insured employer. An employer is not in employer default if it has entered into a repayment agreement with the Insurance Commissioner and remains in compliance with the obligations under the repayment agreement.

**"Related party"** means a party, whether an individual, corporation, partnership, association, limited liability company or any other form or business association or other entity whatsoever, related to any vendor by blood, marriage, ownership or contract through which the party has a relationship of ownership or other interest with the vendor so that the party will actually or by effect receive or control a portion of the benefit, profit or other consideration from performance of a vendor contract with the party receiving an amount that meets or exceeds five percent of the total contract amount.

**AFFIRMATION:** By signing this form, the vendor's authorized signer affirms and acknowledges under penalty of law for false swearing (W. Va. Code §61-5-3) that: (1) for construction contracts, the vendor is not in default on any monetary obligation owed to the state or a political subdivision of the state, and (2) for all other contracts, that neither vendor nor any related party owe a debt as defined above and that neither vendor nor any related party are in employer default as defined above, unless the debt or employer default is permitted under the exception above.

**WITNESS THE FOLLOWING SIGNATURE:**

Vendor's Name: General Sales Administration, Inc. / a Major Police Supply

Authorized Signature: \_\_\_\_\_ Date: 4/26/21

State of New Jersey

County of Morris, to-wit: \_\_\_\_\_

Taken, subscribed, and sworn to before me this 21 day of April, 2021

My Commission expires 2-2-25, 20  

AFFIX SEAL HERE

NOTARY PUBLIC \_\_\_\_\_



STATE OF WEST VIRGINIA  
State Tax Department, Revenue Division  
P. O. Box 2666  
Charleston, WV 25330-2666



Jim Justice, Governor

Dale W. Steager, State Tax Commissioner

GENERAL SALES ADMINISTRATION, INC.  
47 N DELL AVE  
KENVIL NJ 07847-2640

Letter Id: L0451228864  
Issued: 03/28/2017  
Account #: 2339-4976

0000102010000



**RE: Business Registration Certificate**

The West Virginia State Tax Department would like to thank you for registering your business. Enclosed is your Business Registration Certificate. This certificate shall be permanent until cessation of business or until suspended, revoked or cancelled. Changes in name, ownership or location are considered a cessation of business; a new Business Registration Certificate and applicable fees are required. Please review the certificate for accuracy.

This certificate must be prominently displayed at the location for which issued. Engaging in business without conspicuously posting a West Virginia Business Registration Certificate in the place of business is a crime and may subject you to fines per W.Va. Code § 11-9.

When contacting the State Tax Department, refer to the appropriate account number listed on the back of this page. The taxes listed may not be all the taxes for which you are responsible. Account numbers for taxes are printed on the tax returns mailed by the State Tax Department. Failure to timely file tax returns may result in penalties for late filing.

Should the nature of your business activity or business ownership change, your liability for these and other taxes will change accordingly.

To learn more about these taxes and the services offered by the West Virginia State Tax Department, visit our web site at [www.tax.wv.gov](http://www.tax.wv.gov).

Enclosure

atL006 v.4

Save a stamp and your time. You can now view, file and pay taxes at <https://mytaxes.wvtax.gov>  
More taxes will be available for online access in the future.

<u>TAX</u>	<u>FILING FREQUENCY</u>	<u>ACCOUNT NUMBER</u>
Business Registration Tax		2339-4976
Corp. Income & Franchise Tax	Corp Inc & Franchise Annual	2338-7865

WEST VIRGINIA  
STATE TAX DEPARTMENT

**BUSINESS REGISTRATION  
CERTIFICATE**

ISSUED TO:  
**GENERAL SALES ADMINISTRATION, INC.  
47 N DELL AVE  
KENVIL, NJ 07847-2640**

**BUSINESS REGISTRATION ACCOUNT NUMBER: 2339-4976**

This certificate is issued on: **03/28/2017**

*This certificate is issued by  
the West Virginia State Tax Commissioner  
in accordance with Chapter 11, Article 12, of the West Virginia Code*

*The person or organization identified on this certificate is registered  
to conduct business in the State of West Virginia at the location above.*

**This certificate is not transferrable and must be displayed at the location for which issued**  
This certificate shall be permanent until cessation of the business for which the certificate of registration  
was granted or until it is suspended, revoked or cancelled by the Tax Commissioner.

Change in name or change of location shall be considered a cessation of the business and a new  
certificate shall be required.

TRAVELING/STREET VENDORS: Must carry a copy of this certificate in every vehicle operated by them.  
CONTRACTORS, DRILLING OPERATORS, TIMBER/LOGGING OPERATIONS: Must have a copy of  
this certificate displayed at every job site within West Virginia.

# State of West Virginia



## Certificate

*I, Mac Warner, Secretary of State of the  
State of West Virginia, hereby certify that*

**GENERAL SALES ADMINISTRATION, INC.**

**Control Number: 9AHDG**

a corporation formed under the laws of New Jersey has filed its "Application for Certificate of Authority" to transact business in West Virginia as required by the provisions of the West Virginia Code. I hereby declare the organization to be registered as a foreign corporation from its effective date of February 17, 2017.

Therefore, I issue this

### **CERTIFICATE OF AUTHORITY**

to the corporation authorizing it to transact business in West Virginia



*Given under my hand and the  
Great Seal of the State of  
West Virginia on this day of  
February 17, 2017*

*Mac Warner*

*Secretary of State*

West Virginia Secretary of State  
1900 Kanawha Blvd. East  
Bldg. 1, Suite 157-K  
Charleston, WV 25305

FILED

FEB 17 2017



Penney Barker, Manager  
Business & Licensing Division  
Tel: (304)558-8000  
Fax: (304)558-8381  
Website: [www.wvsos.com](http://www.wvsos.com)  
E-mail: [business@wvsos.com](mailto:business@wvsos.com)

Office Hours: Monday - Friday  
8:30 a.m. - 5:00 p.m. EST

**FILE ONE ORIGINAL**

(Two if you want a filed stamped copy returned to you.)

THE OFFICE OF  
SECRETARY OF STATE

**APPLICATION FOR  
CERTIFICATE OF AUTHORITY**

FILING FEE: \$100 (profit)

\$50 (non-profit)

\* Fee Waived for Veteran-owned corporation

Control # 9AHDG

\*\*\* The undersigned, having authority to transact business on behalf of a foreign (out-of-state) registered entity, agrees to \*\*\*  
comply with the requirements of WV Code §31D-15 to apply for Certificate of Authority.

**1. Home State Information:**

- a. The name of the corporation as it is registered in its home state is: GENERAL SALES ADMINISTRATION, INC.
- b. State of NJ Date of Incorporation: NJ Duration (no. yrs. or perpetual): PERPETUAL
- c. NAIC# (if an insurance company): \_\_\_\_\_

**CHECK HERE** to indicate you have obtained and submitted with this application a **CERTIFICATE OF EXISTENCE (GOOD STANDING)**, dated during the current tax year, from your home state of original incorporation as required to process your application. The certificate may be obtained by contacting the Secretary of State's Office in the home state of original incorporation.

**2. Principal Office Information:**

- a. Principal office address of the corporation is:
 

No. & Street: <u>47 N. DELL AVENUE</u>		
City: <u>KENVIL</u>	State: <u>NJ</u>	Zip Code: <u>07847</u>
Street/PO Box: _____		
City: _____	State: _____	Zip Code: _____
- b. Mailing address, if different from above address: \_\_\_\_\_

**3. West Virginia Office Information:**

- a. Corporate name to be used in WV:
 

<input checked="" type="checkbox"/> Home state name as listed on line 1a. above, if available. (If name is not available, check DBA Name box below and follow special instructions under Section 3a. attached to this application.)
<input type="checkbox"/> DBA Name: _____

(See special instructions in Section 3a. regarding the Letter of Resolution approving use of a "forced DBA Name" attached to this application. [Click here](#) to see a sample Letter of Resolution.)

- b. Designated (physical) office address in West Virginia, if any:
 

No. & Street: <u>555 Poca River Road, North</u>		
City: <u>Poca</u>	State: <u>WV</u>	Zip Code: <u>25159</u>
County: <u>Putnam</u>		
Street/PO Box: _____		
City: _____	State: _____	Zip Code: _____
- c. Located in the County of: \_\_\_\_\_
- d. Mailing address in West Virginia, if different from above: \_\_\_\_\_

APPLICATION FOR CERTIFICATE OF AUTHORITY

4. Agent for Service of Process:  
Properly designated person to whom  
notice of legal process may be sent, if  
any.

Name: Registered Agent Solutions, Inc.  
No. & Street: 555 Poca River Road, North  
City: Poca State: WV Zip Code: 25159

5. E-mail address where business correspondence may be received: none

6. Website address of the business, if any (ex: yourdomainname.com):

7. Do you own or operate more than one  Yes \* Answer a. and b. below.  No  Decline to answer  
business in West Virginia?

If "Yes"... a. How many businesses? \_\_\_\_\_ b. Located in how many West Virginia counties? \_\_\_\_\_

8. a. Proposed purpose(s) for transaction of business in West Virginia is(are):

Contractor in the Security Guards and Patrol Services industry & any lawful purpose in furtherance thereof.

b. Will the incorporation elect to be organized for purposes as a "Benefit Corporation" per West Virginia Code §31F? ONLY  
applicable to "FOR PROFIT" corporations; "NON-PROFIT" corporations CANNOT elect this status.

Yes [If "Yes," the corporation must be formed FOR PROFIT and the purpose(s) indicated in Section 10a. above must  
include a "general public benefit" as set forth in §31F-3-301(a) of the West Virginia Code. Per §31F-1-102(e),  
"general public benefit" means "a material positive impact on society and the environment taken as a whole, as  
measured by a third-party standard, from the business and operations of a benefit corporation."].

No [Proceed to Section 9.]

9. Is the business a Scrap Metal Dealer?

Yes [If "Yes," you must complete the Scrap Metal Dealer Registration Form (Form SMD-1) and proceed to Section 10.]

No [Proceed to Section 10.]

10. Corporate Status Information:

a. Corporation is organized as (check one):  For Profit  Non-Profit

b. Officers and Directors: (add additional pages if necessary; please list all officers)

Officer Title	Officer Name	No. & Street Address	City	State	Zip Code
PRESIDENT	J. Bradley Badal	47 N. DELL AVENUE	KENVIL	NJ	07847

APPLICATION FOR CERTIFICATE OF AUTHORITY

11. Is the organization a "veteran-owned" organization?

Effective JULY 1, 2015, to meet the requirements for a "veteran-owned" organization, the entity filing the registration must meet the following criteria per West Virginia Code §59-1-2a:

- 1. A "veteran" must be honorably discharged or under honorable conditions, and
- 2. A "veteran-owned business" means a business that meets one of the following criteria:
  - o Is at least fifty-one percent (51%) unconditionally owned by one or more veterans; or
  - o In the case of a publicly owned business, at least fifty-one percent (51%) of the stock is unconditionally owned by one or more veterans.

Yes (If "Yes," attach Form DD214)  CHECK BOX indicating you have attached Veteran Affairs Form DD214

No

You may obtain a copy of your Veterans Affairs Form DD214 by contacting:

National Personnel Records Center  
 Military Personnel Records  
 1 Archives Drive  
 St. Louis, MO 63138  
 Toll free: 1-86-NARA-NARA or 1-866-272-6272  
 Phone: 314-801-0800  
[www.archives.gov/veterans/military-service-records](http://www.archives.gov/veterans/military-service-records)

Per WV Code §9-1-2(f) effective July 1, 2015, the registration fee is waived for entities that meet the requirements as a "veteran-owned" organization. See attached instructions to determine if the organization qualifies for this waiver. In addition, a "veteran-owned" entity will have four (4) consecutive years of Annual Report fees waived AFTER the organization's initial formation [see WV Code §9-1-2a(m)].

12. The number of acres of land it holds or expects to hold in West Virginia is: 0

13. Contact and Signature Information\* (See below Important Legal Notice Regarding Signature):

a. Contact person to reach in case there is a problem with filing: Steven Weiss Phone: +1 (800) 906-9220

b. Print or type name of signer: J. Bradley Badal Title/Capacity of signer: PRESIDENT

c. Signature:  Date: 01/10/2017

Important Legal Notice Regarding Signature: Per West Virginia Code §31D-1-129. Penalty for signing false document. Any person who signs a document he or she knows is false in any material respect and knows that the document is to be delivered to the secretary of state for filing is guilty of a misdemeanor and, upon conviction thereof, shall be fined not more than one thousand dollars or confined in the county or regional jail not more than one year, or both.

Important Note: This form is a public document. Please do NOT provide any personal identifiable information on this form such as social security number, bank account numbers, credit card numbers, tax identification or driver's license numbers.





STATE OF NEW JERSEY  
DEPARTMENT OF THE TREASURY  
DIVISION OF REVENUE AND ENTERPRISE SERVICES  
SHORT FORM STANDING

GENERAL SALES ADMINISTRATION, INC.  
0100430629

*I, the Treasurer of the State of New Jersey, do hereby certify that the above-named New Jersey Domestic For-Profit Corporation was registered by this office on October 12, 1989.*

*As of the date of this certificate, said business continues as an active business in good standing in the State of New Jersey. Annual Reports are outstanding for the following year(s): 2016*

*I further certify that the registered agent and office are:*

J. BRADLEY BADAL  
47 NORTH DELL AVE  
KENVIL, NJ 07847



*IN TESTIMONY WHEREOF, I have hereunto set my hand and affixed my Official Seal at Trenton, this 10th day of January, 2017*

Ford M. Scudder  
Acting State Treasurer

Certificate Number : 6076875523

Verify this certificate online at

[https://www1.state.nj.us/TYTR\\_StandingCert/JSP/Verify\\_Cert.jsp](https://www1.state.nj.us/TYTR_StandingCert/JSP/Verify_Cert.jsp)



# CERTIFICATE OF LIABILITY INSURANCE

4/1/2022

DATE (MM/DD/YYYY)

3/31/2021

THIS CERTIFICATE IS ISSUED AS A MATTER OF INFORMATION ONLY AND CONFERS NO RIGHTS UPON THE CERTIFICATE HOLDER. THIS CERTIFICATE DOES NOT AFFIRMATIVELY OR NEGATIVELY AMEND, EXTEND OR ALTER THE COVERAGE AFFORDED BY THE POLICIES BELOW. THIS CERTIFICATE OF INSURANCE DOES NOT CONSTITUTE A CONTRACT BETWEEN THE ISSUING INSURER(S), AUTHORIZED REPRESENTATIVE OR PRODUCER, AND THE CERTIFICATE HOLDER.

IMPORTANT: If the certificate holder is an ADDITIONAL INSURED, the policy(ies) must have ADDITIONAL INSURED provisions or be endorsed. If SUBROGATION IS WAIVED, subject to the terms and conditions of the policy, certain policies may require an endorsement. A statement on this certificate does not confer rights to the certificate holder in lieu of such endorsement(s).

PRODUCER LOCKTON COMPANIES 3657 BRIARPARK DRIVE, SUITE 700 HOUSTON TX 77042 866-260-3538	CONTACT NAME:	
	PHONE (A/C, No, Ext):	FAX (A/C, No):
	E-MAIL ADDRESS:	
INSURER(S) AFFORDING COVERAGE		NAIC #
INSURER A: Liberty Surplus Insurance Corporation		10725
INSURER B: See Attached		
INSURER C:		
INSURER D:		
INSURER E:		
INSURER F:		

INSURED 1378892 Safe Fleet Holdings, LLC and its subsidiaries (See Attached Named Insured Schedule) 6800 E. 163rd Street Belton MO 64012

COVERAGES CERTIFICATE NUMBER: 16520472 REVISION NUMBER: XXXXXXXX

THIS IS TO CERTIFY THAT THE POLICIES OF INSURANCE LISTED BELOW HAVE BEEN ISSUED TO THE INSURED NAMED ABOVE FOR THE POLICY PERIOD INDICATED. NOTWITHSTANDING ANY REQUIREMENT, TERM OR CONDITION OF ANY CONTRACT OR OTHER DOCUMENT WITH RESPECT TO WHICH THIS CERTIFICATE MAY BE ISSUED OR MAY PERTAIN, THE INSURANCE AFFORDED BY THE POLICIES DESCRIBED HEREIN IS SUBJECT TO ALL THE TERMS, EXCLUSIONS AND CONDITIONS OF SUCH POLICIES. LIMITS SHOWN MAY HAVE BEEN REDUCED BY PAID CLAIMS.

INSR LTR	TYPE OF INSURANCE	ADDL INSD	SUBR WVD	POLICY NUMBER	POLICY EFF (MM/DD/YYYY)	POLICY EXP (MM/DD/YYYY)	LIMITS
A	<input checked="" type="checkbox"/> COMMERCIAL GENERAL LIABILITY <input type="checkbox"/> CLAIMS-MADE <input checked="" type="checkbox"/> OCCUR	Y	N	1000460878-01	4/1/2021	4/1/2022	EACH OCCURRENCE \$ 2,000,000 DAMAGE TO RENTED PREMISES (Ea occurrence) \$ 500,000 MED EXP (Any one person) \$ XXXXXXXX PERSONAL & ADV INJURY \$ 1,000,000 GENERAL AGGREGATE \$ 4,000,000 PRODUCTS - COMP/OP AGG \$ 4,000,000
	GEN'L AGGREGATE LIMIT APPLIES PER: <input checked="" type="checkbox"/> POLICY <input type="checkbox"/> PRO-JECT <input type="checkbox"/> LOC OTHER:						
	AUTOMOBILE LIABILITY <input type="checkbox"/> ANY AUTO OWNED AUTOS ONLY <input type="checkbox"/> SCHEDULED AUTOS <input type="checkbox"/> HIRED AUTOS ONLY <input type="checkbox"/> NON-OWNED AUTOS ONLY			NOT APPLICABLE			COMBINED SINGLE LIMIT (Ea accident) \$ XXXXXXXX BODILY INJURY (Per person) \$ XXXXXXXX BODILY INJURY (Per accident) \$ XXXXXXXX PROPERTY DAMAGE (Per accident) \$ XXXXXXXX
	UMBRELLA LIAB <input type="checkbox"/> OCCUR EXCESS LIAB <input type="checkbox"/> CLAIMS-MADE DED \$ RETENTION \$			NOT APPLICABLE			EACH OCCURRENCE \$ XXXXXXXX AGGREGATE \$ XXXXXXXX
	WORKERS COMPENSATION AND EMPLOYERS' LIABILITY ANY PROPRIETOR/PARTNER/EXECUTIVE OFFICER/MEMBER EXCLUDED? (Mandatory in NH) <input type="checkbox"/> Y/N If yes, describe under DESCRIPTION OF OPERATIONS below		N/A	NOT APPLICABLE			PER STATUTE <input type="checkbox"/> OTH-ER <input type="checkbox"/> E.L. EACH ACCIDENT \$ XXXXXXXX E.L. DISEASE - EA EMPLOYEE \$ XXXXXXXX E.L. DISEASE - POLICY LIMIT \$ XXXXXXXX
B	Excess Liability	N	N	See Attached	4/1/2021	4/1/2022	See Attached

DESCRIPTION OF OPERATIONS / LOCATIONS / VEHICLES (ACORD 101, Additional Remarks Schedule, may be attached if more space is required)  
Additional Insured in favor of Major Police Supply on the General Liability policy where and to the extent required by written contract.

**CERTIFICATE HOLDER****CANCELLATION** See Attachments

<b>16520472</b> Major Police Supply 47 North Dell Avenue Kenil NJ 07847	SHOULD ANY OF THE ABOVE DESCRIBED POLICIES BE CANCELLED BEFORE THE EXPIRATION DATE THEREOF, NOTICE WILL BE DELIVERED IN ACCORDANCE WITH THE POLICY PROVISIONS.
	AUTHORIZED REPRESENTATIVE  

**Excess Liability \$5M X \$5M**

**Insurer:** Endurance American Specialty Insurance Company NAIC #: 41718

**Policy No.:** ELD30001022302

**Policy Term:** 4/1/2021 - 4/1/2022

**Limits:** \$5M Each Occurrence/\$5M General Aggregate

**Excess Liability \$10M X \$10M**

**Insurer:** Everest Indemnity Insurance Company NAIC# 10851

**Policy No.:** XC5EX00720211

**Policy Term:** 4/1/2021 - 4/1/2022

**Limits:** \$10M Each Occurrence/ \$10M General Aggregate

**Excess Liability \$10M X \$20M**

**Insurer:** Liberty Insurance Underwriters, Inc. NAIC #: 19917  
1000334918-03

**Policy No.:**

**Policy Term:** 4/1/2021 - 4/1/2022

**Limits:** \$10M Each Occurrence/\$10M General Aggregate

**Excess Liability \$15M X \$30M**

**Insurer:** Crum & Forster Specialty Ins. Co. NAIC #: 44520

**Policy No.:** SEO-112469

**Policy Term:** 4/1/2021 - 4/1/2022

**Limits:** \$15M Each Occurrence/\$15M General Aggregate

**Named Insured Schedule**

Safe Fleet Holdings LLC  
Safe Fleet Acquisition Corp.  
ROM Holdings, Inc.  
ROM Acquisition Corporation (DBA: ROM Corporation)  
IEM, Inc. (DBA: Prime Design)  
Fire Research Corp.  
Randall Manufacturing LLC  
SMC/CPC Holdings, Inc.  
Specialty Manufacturing, Inc.  
Rear View Safety LLC  
Coban Technologies, Inc.  
SEON Holdings Corp.  
SEON Design (USA) Corp.  
Elkhart Brass Manufacturing Company, LLC  
American Van Equipment, LLC  
Roll-Rite, LLC  
Roll-Rite LLC (DBA: Pulltarps Manufacturing)  
SF Mobile-Vision, Inc.  
American Midwest Manufacturing, Inc.

STATE OF NEW JERSEY  
BUSINESS REGISTRATION CERTIFICATE

DEPARTMENT OF TREASURY  
DIVISION OF REVENUE  
PO BOX 242  
TRENTON, NJ 08646-0252

TAXPAYER NAME:

GENERAL SALES ADMINISTRATION, INC.

TRADE NAME:

MAJOR POLICE SUPPLY

TAXPAYER IDENTIFICATION#:

223-004-242/000

SEQUENCE NUMBER:

0099842

ADDRESS:

47 N-DELL AVENUE  
KENNIL NJ-07847

ISSUANCE DATE:

09/29/04

EFFECTIVE DATE:

10/12/89

FORM-BRC(08-01)

Acting Director

This Certificate is NOT assignable or transferable. It must be conspicuously displayed at above address.

STATE OF NEW JERSEY  
DEPARTMENT OF THE TREASURY  
SHORT FORM STANDING

STATE OF NEW JERSEY  
DEPARTMENT OF THE TREASURY  
SHORT FORM STANDING

GENERAL SALES ADMINISTRATION, INC.

0100430629

I, the Treasurer of the State of New Jersey, do hereby certify that the above-named New Jersey Domestic Profit Corporation was registered by this office on October 12, 1989.

As of the date of this certificate, said business continues as an active business in good standing in the State of New Jersey, and its Annual Reports are current.

I further certify that the registered agent and registered office are:

J. Bradley Badal  
47 North Dell Ave  
Kenvil, NJ 07847



Certification# 123278799

IN TESTIMONY WHEREOF, I have  
hereunto set my hand and affixed my  
Official Seal at Trenton, this  
6th day of March, 2012

A handwritten signature in black ink, appearing to read "Andrew P. Sldamon-Eristoff".

Andrew P Sldamon-Eristoff  
State Treasurer

Verify this certificate at  
[https://www1.state.nj.us/TYTR\\_StandingCert/JSP/Verify\\_Cert.jsp](https://www1.state.nj.us/TYTR_StandingCert/JSP/Verify_Cert.jsp)

Certificate Number  
672663

Registration Date: 08/21/2011  
Expiration Date: 08/20/2013



# State of New Jersey

## Department of Labor and Workforce Development Division of Wage and Hour Compliance

### Public Works Contractor Registration Act

Pursuant to N.J.S.A. 34:11-56.48, et seq. of the Public Works Contractor Registration Act, this certificate of registration is issued for purposes of bidding on any contract for public work or for engaging in the performance of any public work to:

General Sales Administration a Major Police Supp

2011

Responsible Representative(s):

John B. Badal, President  
Bruce Bendell, Vice-President

Responsible Representative(s):

Handwritten signature of Harold J. Wirths in cursive.

Harold J. Wirths, Commissioner  
Department of Labor and Workforce Development

NON TRANSFERABLE

This certificate may not be transferred or assigned and may be revoked for cause by the Commissioner of Labor and Workforce Development.

Certification 16090

# CERTIFICATE OF EMPLOYEE INFORMATION REPORT RENEWAL

This is to certify that the contractor listed below has submitted an Employee Information Report pursuant to N.J.A.C. 17:27-1.1 et. seq. and the State Treasurer has approved said report. This approval will remain in effect for the period of

15 FEB 2015 TO 15 FEB 2022

GENERAL SALES ADMINISTRATION, INC. T/A MAJOR  
47 NORTH DELL AVENUE  
KENVIL NJ 07847

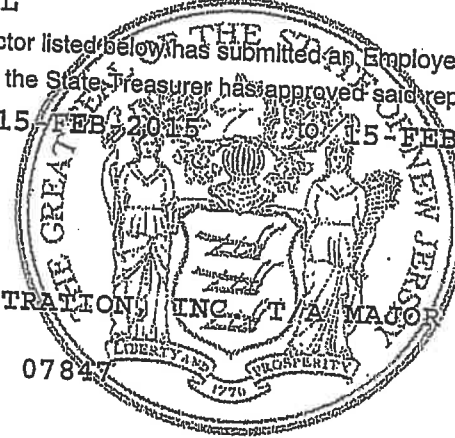

A handwritten signature in black ink, appearing to read "Andrew P. Sidamon-Eristoff".

Andrew P. Sidamon-Eristoff  
State Treasurer



# FUSION 44" LIGHTBAR



PART NUMBER: **FN-4420**



## KEY FEATURES

- 360° unobstructed lighting
- 180° or 40° light spread optic available
- Single Color: 16 flash patterns
- Dual Color: 48 flash patterns
- Available Colors:  
*R, B, A, W, G, RW, BW, AW, AR, AB, RB*
- Rugged, weather-resistant enclosure
- Capabilities:
  - 3 programmable modes
  - Rear Directional
  - Dimming
  - Front and rear cutoff
  - Cruise mode
  - Takedown
  - Alley and work light
  - Flood mode for dual color
  - Optional stop/tail/turn



## QUICK FACTS

- Made in the USA
- Available in Single or Dual Color
- 3M Triple-bubble Seal
- 15' Cable Harness
- Easy Field Serviceability
- Clear-coated polycarbonate lens:  
*Anti-cracking & Anti-yellowing*
- 4 Mounting Options:



## SPECIFICATIONS

Dimensions 1.8" x 12.1" x 44.5"

Warranty 5 years

Voltage 10-18 Volts DC

Current Draw 15 Amps

## WIRING DIAGRAM

Wire:	Function:
Red	12V+ Positive
Black	12V- Ground



Fusion 44" Lightbar Instruction Manual  
1.800.615.8350 / fenex.com

# FUSION GPL

GENERATION PERFECTION LIGHTBAR

## FUSION 44" LIGHTBAR FN-4420

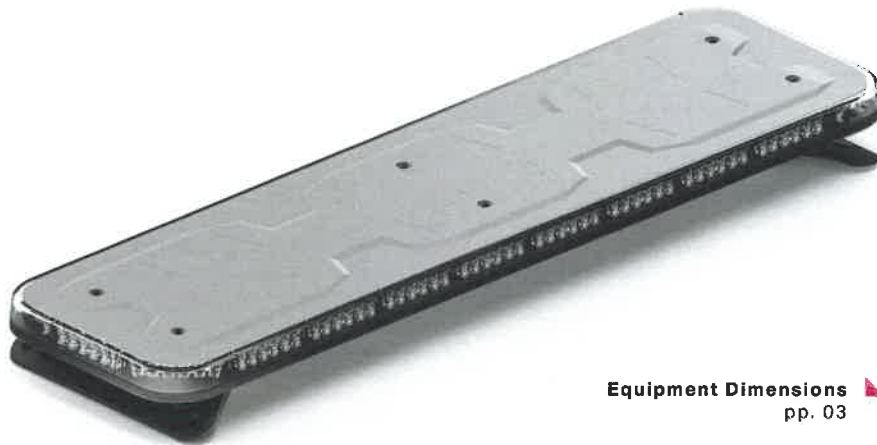

**Equipment Dimensions** ▲  
pp. 03

**Specifications** ▲  
pp.03

**Flash Patterns** ▲  
pp.04

**Wiring Diagram/Information/Functions** ▲  
pp.05 - 07



**Fenex Product Copyrights** This price list and the mentioned Fenex products include or describe copyrighted Fenex material. Laws in the United States and other countries preserve for Fenex Industries and its licensors certain exclusive rights for copyrighted material, including the exclusive right to copy, reproduce in any form, distribute and make derivative works of the copyrighted material. Accordingly, any copyrighted material of Fenex and its licensors contained herein or in the Fenex products described in this Price List may not be copied, reproduced, distributed, merged or modified, transmitted, transcribed, stored in retrieval system or translated into any language or computer language, in any form or by any means, without prior written permission of Fenex Industries, Inc. Fenex and the stylized Fenex logo are registered in the U.S. Patent & Trademark Office.



## SAFETY REGULATIONS & WARRANTY

### Safety Regulations

The following provides all the information necessary to safely operate the previously listed products of Feniex Industries, Inc. Please read this manual thoroughly before installing or operating your new product in order to prevent any damage or injury. Failure to follow the listed instructions in this manual may result in damage to your products or personal injury.

- Proper installation of this product requires good knowledge of automotive systems, electronics and procedures.
- Please guarantee all vital components of the vehicle are not in danger of being damaged by drilling holes necessary for installation. Check all sides of the mounting surface before drilling any holes into the vehicle.
- Do not install this product in any way that interferes with the deployment of the air bag. Doing so may damage the effectiveness of the air bag and can lead to serious personal and vehicle injury. The installer will assume full responsibility of proper installation of the new unit.
- Please clean the mounting surface before installation of the unit when using tape, brackets, magnet, Velcro or suction cups.
- The product's ground wire must be connected directly to the Negative (-) battery post for effective use of the unit. Please follow all wiring guidelines provided to guarantee long lifespan and productivity. Failing to follow these instructions may result in damage to the product.

### Warranty

Feniex Industries' speakers, sirens, rocker panels, AM600 Beacons, Torch Lights, AI lightbars, AI Cubes, AM900 Work Lights and controllers are warranted for 2 years from the manufacturing date. In addition, all other products are warranted for 5 years from the manufacturing date.

If a warranty problem occurs, please contact customer support at 1.800.615.8350 or visit the web site at [www.Feniex.com](http://www.Feniex.com). If the product needs to be returned for repair or replacement, call our customer support line to receive a return merchandise authorization number.

Operational times are from 10 a.m. to 5 p.m. central time, Monday through Friday. Please do not send in product without contacting support first for a RMA number.

### Service After Expiration

Feniex Industries will still provide service for all products after expiration of the warranty. For any issues, call the customer support line. In some instances it may be necessary for the product to be shipped, freight prepaid and insured for loss or damage to Feniex headquarters.

**Warning!** Utilizing non-factory screws and mounting brackets may result in loss of warranty coverage.

### Copyright

This instruction manual and the Feniex products described in this instruction manual may include or describe copyrighted Feniex material. Laws in the United States and other countries preserve for Feniex Industries and its licensors certain exclusive rights for copyrighted material, including the exclusive right to copy, reproduce in any form, distribute and make derivative works of the copyrighted material. Accordingly, any copyrighted material of Feniex and its licensors contained herein or in the Feniex products described in this instruction manual may not be copied, reproduced, distributed, merged or modified in any manner without the express written permission of Feniex Industries, Inc.

### Feniex Product Copyrights

The products described in this document are the property of Feniex Industries, Inc. It is furnished by express license agreement only and may be used only in accordance with the terms of such an agreement. Products and documentation are copyrighted materials. Making unauthorized copies is prohibited by law. No part of the product or documentation may be reproduced, transmitted, transcribed, stored in retrieval system or translated into any language or computer language, in any form or by any means, without prior permission from Feniex Industries, Inc.



## EQUIPMENT DIMENSIONS

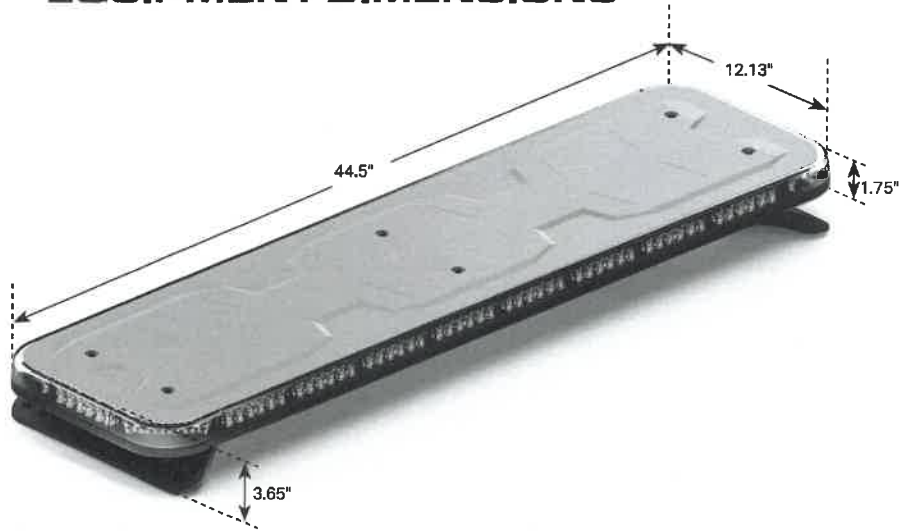

## SPECIFICATIONS

Warranty	5 years
Voltage	10-18 Volts DC
Current Draw	15 Amps
Input Power	12 VDC
External Fuse	125% of Circuit Load
SAE Certificate	Class 1, J595, CT13, J11113-11
Colors	Amber, Red, Blue, White & Green

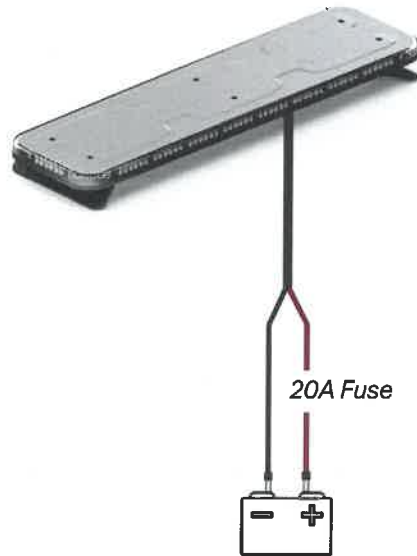



## FLASH PATTERNS

### CRUISE PATTERNS

Activate Cruise Mode by extending the green wire to a 12v (+) latching switch.

1. Apply 12v (+) to the green wire.
2. Apply 12v (+) (momentary) to the red/white wire to advance the pattern of the cruise mode.

- 1 All-On
- 2 Single Slow
- 3 Single Fast
- 4 Single Slow - Alternating
- 5 Single Fast - Alternating
- 6 Single Slow Corners - Alter.
- 7 Single Fast Corners - Alter.
- 8 Attack Pattern

### FLOOD PATTERNS

Activate Flood Mode by extending the green/black wire to a 12v (+) latching switch.

To activate flood mode, use the red/white pattern change wire to select the desired flood mode.

- 1 Front Modules
- 2 Front & Side Modules (no alley)
- 3 Front, Side (no alley), & Rear/Arrow Modules
- 4 Side & Rear/Arrow Modules
- 5 Rear/Arrow Modules

### FLASH PATTERNS

- 1 Cluster Pattern
- 2 Attack Pattern
- 3 Night Ride Pattern
- 4 Half-Half [Slow]
- 5 Half-Half [Fast]
- 6 One-One [Slow]
- 7 One-One [Fast]
- 8 Two-Two [Slow]
- 9 Two-Two [Fast]
- 10 All-On [Fast]
- 11 All-On [Slow]
- 12 In-Out [Slow]
- 13 In-Out [Fast]
- 14 Combo: All Slow
- 15 Combo: All Fast
- 16 Combo: Fast & Slow  
*\*Single & Dual Color Modes*



## WIRING DIAGRAMS

	Green/White	Mode 0 Rear	12V+	Activates rear-facing modules, corners & sides
	Blue/White	Mode 0 Front	12V+	Activates front-facing modules & corners
	Black	Mode 1	12V-	Warning Mode 1. <i>Overrides Mode 0</i>
	Red	Mode 2	12V+	Warning Mode 2. <i>Overrides Mode 0 &amp; 1</i>
	Orange	Mode 3	12V+	Warning Mode 3. <i>Overrides Mode 0, 1 &amp; 2</i>
	Green	Cruise Mode	12V+	Corner Modules. <i>10% Brightness</i>
	Blue	Takedown	12V+	Overrides Modules 1, 2 & 3 Flash Patterns
	Red/Black	Left Alley	12V+	Steady Burn. <i>Overrides Flashing</i>
	White	Right Alley	12V+	Steady Burn. <i>Overrides Flashing</i>
	Orange/Black	Flashing TD/Alley	12V+	Flashes Takedown & Alley Lights
	Green/Black	Flood Mode	12V+	Activates Flood Mode.
	Blue/Black	Dim	12V+	Dims Lightbar. Takedown, Alley & Flood Unaffected
	White/Black	Arrow Left	12V+	Left Arrow. <i>Overrides Flashing</i>
	Black/White	Arrow Right	12V+	Right Arrow. <i>Overrides Flashing</i>
	W/B + B/W	Center Out	12V+	Center-Out Arrow. <i>Overrides Flashing</i>
	Red/White	Pattern Changer	12V+	Momentary, cycles through

### DIM MODE

Activate the flash mode by applying the flashmode wire to a 12V(+). Activate Dim Mode by extending the blue/black wire to a 12v (+). Tap the pattern changer, red/white wire to cycle through the dim modes.

### **ATTENTION:**

Dim Mode is only available on hard-wire models. This mode will dim all modes except for Takedown functions & Flood Mode.



## ▲ WIRING INFORMATION & FUNCTIONS

### POWER CABLE WIRING

1. Install a customer supplied fuse rated for 125% of the circuit load to the end of the red wire. Do not use a circuit breaker or fusible link.
2. Connect the opposite end of the fuse to the 12v+ terminal of the battery. Do not use more than 1 foot of wire between the fuse and the battery terminal to ensure appropriate protection.
3. Connect the black wire to the vehicle chassis ground.
4. Connect the function wires to switches, depending on the functions needed for applications (See page 6 for wiring diagrams).

■ Black	Ground	12V-	Connect to vehicle's negative battery post
■ Red	Positive	12V+	Connect to vehicle's positive battery post

### **ATTENTION:**

All user supplied wires connecting to 12v (+) or 12v (-) must be sized to supply 100% of the maximum current and properly fused at the power source with a fuse rated at 125% of the total circuit load.

Avoid routing wires in the deployment area of the vehicle air bag or any other potentially hazardous locations.

### STOP|TAIL|TURN & WORK LIGHTS

Work Light and Stop/Tail/Turn functionality must be specified at time of order. Modules in work light and/or STT positions will only function as such.

No warning patterns will be displayed in work light or STT positions.

■ Orange	Tail Lights	12V+	Steady Burn of both tail lights. <i>10% Brightness</i>
■ Red	Work Lights	12V+	Steady Burn
■ Green	Left Brake/Turn	12V+	Overrides Tail Light
■ Blue/Black	Right Brake/Turn	12V+	Overrides Tail Light



## ▲ WIRING INFORMATION & FUNCTIONS

### TAKEDOWN

Activate the factory configured takedown function by extending the white wire to a 12v (+) latching switch.

### ALLEY LIGHTS

Activate the factory configured alley lights by extending the red/black & white wires to 12v (+) latching switches.

### TAKEDOWN & ALLEY FLASHING

Activate the factory configured takedown flashing function by extending the green wire to a 12v (+) latching switch. For dual color models, warning mode 2 will be activated instead of the flashing takedown function.

#### **ATTENTION:**

Takedown & alley functionality must be specified at time of order. Modules in takedown and/or alley positions will only function as such, or flashing takedown/alley. No warning patterns will be displayed in takedown or alley positions.

### WARNING MODES

Warning modes 0 and 1 can be configured to use either the front or rear without activating the full lightbar. Modes 2 and 3 can only be programmed to have the full bar on or off.

■ **Programming Mode 0:** Activate the mode by extending the blue/white (front wire) or the green/white (rear wire) to a 12v (+) source. The front and rear can be used together only if the same flash pattern is selected.

■ **Programming Mode 1:** Activate the mode by extending the blue/white (front wire) or the green/white (rear wire) to a 12v (+) source. Overrides Mode 0. Mode 0 needs to be activated for Mode 1 to function.

■ **Programming Mode 2 & 3:** Activate the mode by extending the mode wire to a 12v (+) source. Mode 2 overrides Modes 0 and 1. Mode 3 overrides Modes 0, 1 and 2.

### ARROW FUNCTIONS

Activate the arrow functions by extending the white/black wire, black/white wire, or a combination of both to 12v (+) latching switches.

#### **ATTENTION:**

Arrow functions will override all warning modes on all rear-facing modules (not including corners).





## 4200 DATA LINK CONTROLLER

When using the data link, connect the RJ45 connection to the 4200 Relay. Use the 4200 Software to program the desired function of the Fusion 44" Lightbar.

**⚠ ATTENTION:**

When the RJ45 Data Link wire is connected to the 4200 Relay, this will override any other wire input to the Fusion 44" Lightbar. You can either use Data Link or the Lightbar wire harness, but not both.



*4200 Controller & Data Link Relay*

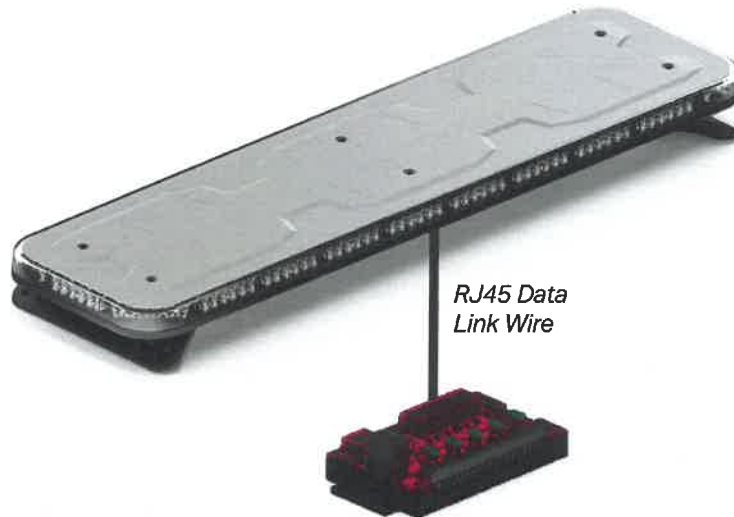

*RJ45 Data Link Wire*



## ▲ HOOK KIT INSTRUCTIONS

### INSTALLING A HOOK BRACKET

1. Remove the hex bolt from its packaging and slide the bolt through the hook bracket hole.
2. Using a socket wrench and the hex bolt, loosely secure the hook bracket to the threaded hole in the foot bracket. Repeat on the other side of the lightbar so both sides have the hook bracket secured.
3. Place the lightbar with the attached hook brackets on the vehicle. Ensure the hook bracket is up right and seated correctly.
4. Secure and tighten the bracket using a socket wrench on each side of the vehicle until the bar is snugly mounted. Use the included lock nut as a jam nut for extra security. Ensure the vehicle's door will close without any interference.

**⚠ ATTENTION:**

*Do not overtighten the hex bolts. Do not exceed 165 in. lb. The use of blue thread locker is suggested.*

5. Drill and secure the bracket to the vehicle with self-tapping screws, using the two pilot holes on the bottom of the hook bracket as a guide.
6. Once the bar is secure, drill a one inch hole to route the wire harness through the vehicle and then seal the hole with silicone. Ensure that wires are protected from rough edges using a rubber wire grommet.

**⚠ ATTENTION:**

*Utilizing non-factory hardware and mounting brackets may result in loss of warranty.*



# FUSION® GPL 49"



PART NUMBER: FN-4918

## KEY FEATURES:

- The brightest, highest performing light bar manufactured in the USA. High-powered and densely packed with CREE LEDs, the Fusion GPL is engineered to simplify the overly-complicated lightbar market with multiple points of perfection (see diagram below).
- Capabilities: 3 programmable modes, rear directional, dimming, front and rear cutoff, cruise mode, takedown, alley and work light, flood mode for dual color, optional Stop/Tail/Turn
- **NEW:** Dim mode capable (see Instruction Manual)

## QUICK FACTS:

- Available Colors: R, B, A, W, G, RW, BW, AW, AR, AB, RB
- Certifications: SAE J1113, SAE J845, SAE J595, SAE J578, SAE J575, CT 13, NFPA, R65
- 4 mounting options: Multiple hook kits, headache rack, permanent mount, adjustable foot mount
- 180° or 40° light spread optics available in single and dual color
- Reverse polarity protected

## SPECIFICATIONS:

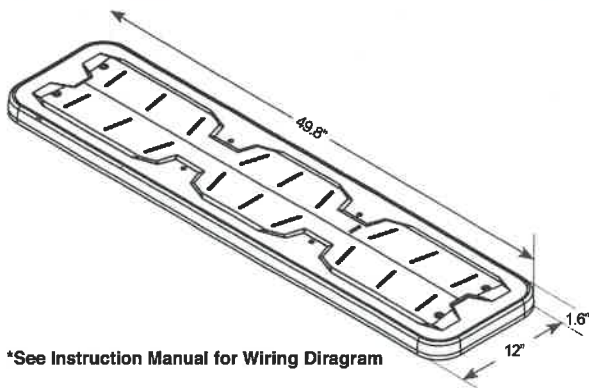

\*See Instruction Manual for Wiring Diagram

Dimensions (including feet)	49.8" L x 12" W x 1.6" H
Warranty	5 years
Cable Harness Length	15 feet
Voltage	12VDC
Current Draw	15A (fuse @125%)
Single Color	156 high power 4 Watt Cree LED's
Dual Color	312 high power 4 Watt Cree LED's

## POINTS OF PERFECTION:

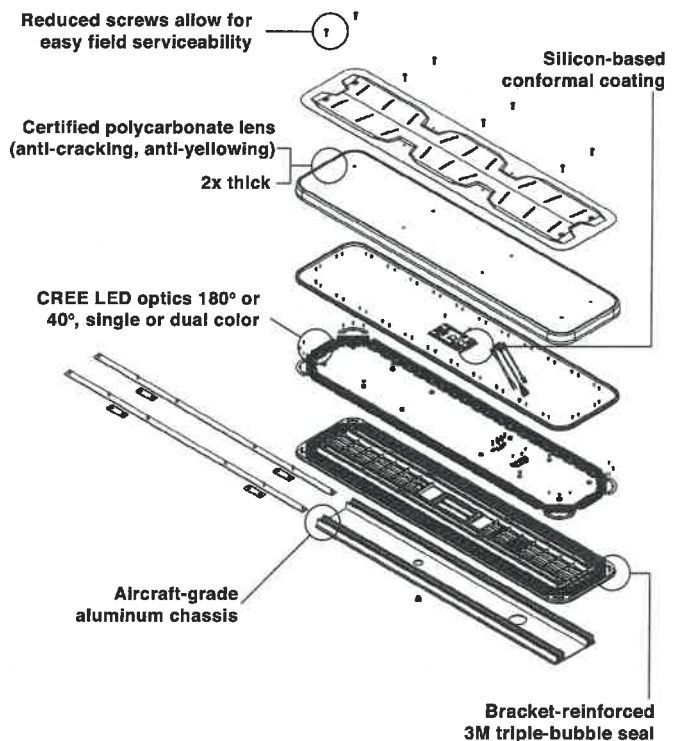

# FUSION GPL

GENERATION PERFECTED LIGHTBAR



FN-4918

**INSTRUCTION MANUAL**



Fenix Product Copyrights This price List and the mentioned Fenix products include or describe copyrighted Fenix material. Laws in the United States and other countries preserve for Fenix Industries and its licensors certain exclusive rights for copyrighted material, including the exclusive right to copy, reproduce in any form, distribute and make derivative works of the copyrighted material. Accordingly, any copyrighted material of Fenix and its licensors contained herein or in the Fenix products described in this Price List may not be copied, reproduced, distributed, merged or modified, transmitted, transcribed, stored in retrieval system or translated into any language or computer language, in any form or by any means, without prior written permission of Fenix Industries, Inc. Fenix and the stylized Fenix logo are registered in the U.S. Patent & Trademark Office.



# TABLE OF CONTENTS



<b>Safety Regulations &amp; Warranty</b> .....	3
Service after Expiration .....	3
Copyright .....	3
Fenix Product Copyright .....	3
<b>Specifications, Flash Patterns, &amp; Wiring</b> .....	4
Specifications .....	4
Flash Patterns .....	4
Cruise Flash Patterns .....	4
Flood Mode Options .....	4
Box Contents .....	4
Mount Kits .....	4
Equipment Dimensions .....	4
<b>Wiring Diagrams</b> .....	5
Power Connection .....	5
Standard Configuration .....	5
Stop/Tail/Turn & Work Lights .....	5
<b>Wiring Information &amp; Functions</b> .....	6
Power Cable Wiring .....	6
Warning Mode Activation .....	6
Flash Pattern Selection .....	6
Flood Mode Activation .....	6
Flood Mode Selection .....	6
Takedown Activation .....	6
Alley Light Activation .....	6
Cruise Mode Activation .....	6
Cruise Pattern Selection .....	6
Dim Mode Activation .....	6
Arrow Function Activation .....	6
Work Light Activation .....	6
<b>Mounting Straps &amp; Brackets</b> .....	7
Vehicle Specific Hook Mounts .....	7
Universal Mounts .....	7
<b>Hook Kit Installation</b> .....	8

# SAFETY REGULATIONS & WARRANTY

## SAFETY REGULATIONS

The following provides all the information necessary to safely operate the previously listed products of Feniex Industries, Inc. Please read this manual thoroughly before installing or operating your new product in order to prevent any damage or injury. Failure to follow the listed instructions in this manual may result in damage to your products or personal injury.

- Proper installation of this product requires good knowledge of automotive systems, electronics & procedures.
- Please guarantee all vital components of the vehicle are not in danger of being damaged by drilling holes necessary for installation. Check all sides of the mounting surface before drilling any holes into the vehicle.
- Do not install this product in any way that interferes with the deployment of the air bag. Doing so may damage the effectiveness of the air bag & can lead to serious personal and vehicle injury. The installer will assume full responsibility of proper installation of the new unit.
- Please clean the mounting surface before installation of the unit when using tape, brackets, magnet, Velcro or suction cups.
- The product's ground wire must be connected directly to the negative (-) battery post for effective use of the unit. Please follow all wiring guidelines provided to guarantee long lifespan & productivity. Failing to follow these instructions may result in damage to the product.

## WARRANTY

Feniex Industries, Inc. warrants to the original purchaser that the product shall be free from defects in material & workmanship for 5 years from the date of purchase for all LED products. Feniex Industries warranties speakers, sirens, flashers, & controllers for 2 years.

If warranty service is needed, please contact customer support:

**Phone:** 1.800.615.8350

**Web Site:** [www.Feniex.com/support](http://www.Feniex.com/support)

**Email:** [techsupport@feniex.com](mailto:techsupport@feniex.com)

If the product needs to be returned for repair or replacement, contact our customer service team (using any method listed above) to receive a Return Merchandise Authorization (RMA) number. Operational times are from 9 a.m. to 6 p.m. central time, Monday through Friday.

 Please do not send in product without contacting support first for a Return Merchandise Authorization (RMA) number.

## CONDITIONS

Feniex Industries, Inc. will not be held responsible for any costs associated with equipment removal and/or re-installation resulting from a warranty claim. It is the sole responsibility of the party initiating a warranty claim to pay shipping charges associated with returning a product to Feniex Industries for repair or replacement.

## SERVICE AFTER EXPIRATION

Feniex Industries will still provide service for all products after expiration of the warranty. For any issues, call the customer support line. In some instances it may be necessary for the product to be shipped, freight prepaid and insured for loss or damage to Feniex headquarters.

 Utilizing non-factory screws and mounting brackets may result in the loss of warranty coverage.

## COPYRIGHT

This instruction manual and the Feniex products described in this instruction manual may include or describe copyrighted Feniex material. Laws in the United States and other countries preserve for Feniex Industries and its licensors certain exclusive rights for copyrighted material, including the exclusive right to copy, reproduce in any form, distribute and make derivative works of the copyrighted material. Accordingly, any copyrighted material of Feniex and its licensors contained herein or in the Feniex products described in this instruction manual may not be copied, reproduced, distributed, merged or modified in any manner without the express written permission of Feniex Industries, Inc.

## FENIEX PRODUCT COPYRIGHTS

The products described in this document are the property of Feniex Industries, Inc. It is furnished by express license agreement only and may be used only in accordance with the terms of such an agreement. Products and documentation are copyrighted materials. Making unauthorized copies is prohibited by law. No part of the product or documentation may be reproduced, transmitted, transcribed, stored in retrieval system or translated into any language or computer language, in any form or by any means, without prior permission from Feniex Industries, Inc.

# SPECIFICATIONS, PATTERNS, & WIRING

## SYSTEM SPECIFICATIONS

Input Power	12 VDC
Current Draw	15 Amps
External Fuse	125% of Circuit Load
Cable	15 Feet
Colors	Amber, Red, Blue, White, Green
SAE Certification	Class 1, J595, CT13, J1113-11
Flash Patterns	48 Total
LED Technology	Cree, 4 Watt
Dimensions	49.8" L x 1.6" H x 11.8" W
Warranty	5 Years

## FLASH PATTERNS

1) Cluster Pattern	Single & Dual Color Modes
2) Attack Pattern	Single & Dual Color Modes
3) Night Ride Pattern	Single & Dual Color Modes
4) Half-Half [Slow]	Single & Dual Color Modes
5) Half-Half [Fast]	Single & Dual Color Modes
6) One-One [Slow]	Single & Dual Color Modes
7) One-One [Fast]	Single & Dual Color Modes
8) Two-Two [Slow]	Single & Dual Color Modes
9) Two -Two [Fast]	Single & Dual Color Modes
10) All-On [Slow]	Single & Dual Color Modes
11) All-On [Fast]	Single & Dual Color Modes
12) In-Out [Slow]	Single & Dual Color Modes
13) In-Out [Fast]	Single & Dual Color Modes
14) Combo: All Slow	Single & Dual Color Modes
15) Combo: All Fast	Single & Dual Color Modes
16) Combo: Fast & Slow	Single & Dual Color Modes

## CRUISE FLASH PATTERNS

- 1) All On
- 2) Single Flash [Slow], Simultaneous
- 3) Single Flash [Flash], Simultaneous
- 4) Single Flash [Slow], Alternating
- 5) Single Flash [Flash], Alternating
- 6) Single Flash [Slow], Corners, Alternating
- 7) Single Flash [Fast], Coners, Alternating
- 8) Attack Pattern

## FLOOD MODE OPTIONS

- 1) Front Modules
- 2) Front & Side Modules (excluding alley)
- 3) Front, Side (excluding alley), & Rear/Arrow Modules
- 4) Side & Rear/Arrow Modules
- 5) Rear/Arrow Modules

## BOX CONTENTS



BOX CONTENTS	QUANTITY
1. Fusion 49" GPL	1
2. Standard Foot Mount	2*

\*Permanent or Headache Rack Mounts may be substituted at time of purchase

MOUNT KITS*	PART NUMBER
Standard Foot Mount	FN-9716-M-F*
Permanent Mount	FN-9916-M-P*
Headache Rack Mount	FN-9816-M-H*
Adjustable Foot Mount	FN-9927-AF*

\*Sold Separately, in pairs

**!** See page 8 for a full list of available vehicle specific light bar strap kits.

## DIMENSIONS

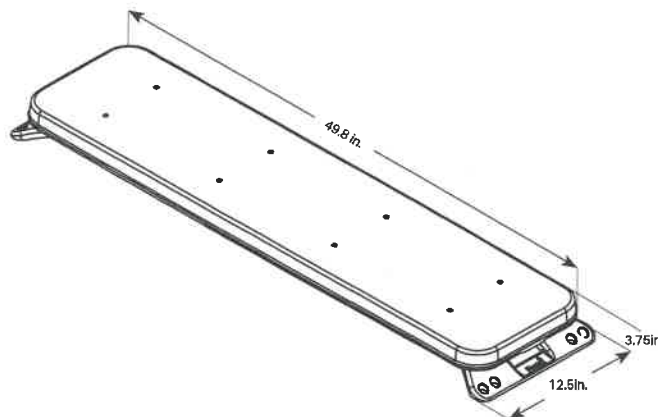

# WIRING DIAGRAMS



## WIRING DIAGRAM: POWER CONNECTIONS

Wire Color	Function	Polarity	Description
Black	Ground	12v (-)	Connect to vehicle's negative battery post
Red	Positive	12v (+)	Connect to vehicle's positive battery post

 All user supplied wires connecting to 12v (+) or 12v (-) must be sized to supply 100% of the maximum current and properly fused at the power source with a fuse rated at 125% of the total circuit load. Avoid routing wires in the deployment area of the vehicle air bag or any other potentially hazardous locations.

## WIRING DIAGRAM: STANDARD CONFIGURATION

Wire Color	Function	Polarity	Description
Green/White	Mode 0 Rear	12v (+)	Activates rear-facing modules, corners, & sides
Blue/White	Mode 0 Front	12v (+)	Activates front-facing modules & corners
Black	Mode 1	12v (+)	Warning Mode 1 [Overrides Mode 0]
Red	Mode 2	12v (+)	Warning Mode 2 [Overrides Mode 0 & 1]
Orange	Mode 3	12v (+)	Warning Mode 3 [Overrides Modes 0, 1 & 2]
Green	Cruise Mode	12v (+)	Corner Modules [10% Brightness]
Blue	Takedown	12v (+)	Overrides Modes 1, 2, & 3 Flash Patterns
Red/Black	Left Alley	12v (+)	Steady Burn [Overrides Flashing]
White	Right Alley	12v (+)	Steady Burn [Overrides Flashing]
Orange/Black	Flashing TD/Alley	12v (+)	Flashes Takedown & Alley Lights
Green/Black	Flood Mode	12v (+)	Activates Flood Mode [if dual color, if configured]
Blue/Black	Dim	12v (+)	Dims Lightbar [Takedown, Alley, & Flood Unaffected]
White/Black	Arrow Left	12v (+)	Left Arrow [Overrides Flashing]
Black/White	Arrow Right	12v (+)	Right Arrow [Overrides Flashing]
Wht/Blk + Blk/Wht	Center Out	12v (+)	Center-Out Arrow [Overrides Flashing]
Red/White	Pattern Changer	12v (+)	Momentary, cycles through flash patterns

## WIRING DIAGRAM: STOP/TAIL/TURN & WORK LIGHTS

Wire Color	Function	Polarity	Description
Black	Tail Lights	12v (+)	Steady Burn of both tail lights [10% Brightness]
Red	Work Lights	12v (+)	Steady Burn
Green/White	Left Brake/Turn	12v (+)	[Overrides Tail Light]
Blue/White	Right Brake/Turn	12v (+)	[Overrides Tail Light]



## WIRING INFORMATION & FUNCTIONS

### POWER CABLE WIRING

1) Install a customer supplied fuse rated for 125% of the circuit load to the end of the red wire. Do not use a circuit breaker or fusible link.

2) Connect the opposite end of the fuse to the 12v+ terminal of the battery. Do not use more than 1 foot of wire between the fuse and the battery terminal to ensure appropriate protection.

3) Connect the black wire to the vehicle chassis ground.

4) Connect the function wires to switches, depending on the functions needed for applications (See page 6 for wiring diagrams).

### WARNING MODES

Warning modes 0 and 1 can be configured to use either the front or rear without activating the full lightbar. Modes 2 and 3 can only be programmed to have the full bar on or off.

**Programming Mode 0:** Activate the mode by extending the blue/white (front wire) or the green/white (rear wire) to a 12v (+) source. The front and rear can be used together only if the same flash pattern is selected.

**Programming Mode 1:** Activate the mode by extending the blue/white (front wire) or the green/white (rear wire) to a 12v (+) source. Overrides Mode 0. Mode 0 needs to be activated for Mode 1 to function.

**Programming Mode 2 & 3:** Activate the mode by extending the mode wire to a 12v (+) source. Mode 2 overrides Modes 0 and 1. Mode 3 overrides Modes 0, 1 and 2.

### FLASH PATTERNS

Advance the pattern by extending the red/white wire to a 12v (+) momentary switch or tap the red/white wire to a 12v (+) terminal for 1 second.

## WIRING INFORMATION & FUNCTIONS



Work Light and Stop/Tail/Turn functionality must be specified at time of order. Modules in work light and/or STT positions will only function as such. No warning patterns will be displayed in work light or STT positions.

### FLOOD MODE

Activate flood mode by extending the green/black wire to a 12v (+) latching switch.

### FLOOD MODE SELECTION

Activate flood mode and use the red/white pattern change wire to select the desired flood mode.

### TAKEDOWN

Activate the factory configured takedown function by extending the white wire to a 12v (+) latching switch.

### ALLEY LIGHTS

Activate the factory configured alley lights by extending the red/black & white wires to 12v (+) latching switches.



Takedown & alley functionality must be specified at time of order. Modules in takedown and/or alley positions will only function as such, or flashing takedown/alley. No warning patterns will be displayed in takedown or alley positions.

### TAKEDOWN & ALLEY FLASHING

Activate the factory configured takedown flashing function by extending the green wire to a 12v (+) latching switch. For dual color models, warning mode 2 will be activated instead of the flashing takedown function.

### CRUISE MODE

Activate Cruise Mode by extending the green wire to a 12v (+) latching switch.

### CRUISE PATTERN SELECTION

1) Apply 12v (+) to the cruise mode wire (green).

2) Apply 12v (+) (momentary) to the red/white wire to advance the pattern of the cruise mode.

### DIM MODE

Activate Dim Mode by extending the blue/black wire to a 12v (+) latching switch.



Dim Mode is only available on hard-wire models. This mode will dim all modes except for Takedown functions & Flood Mode.

### ARROW FUNCTIONS

Activate the arrow functions by extending the white/black wire, black/white wire, or a combination of both to 12v (+) latching switches.



Arrow functions will override all warning modes on all rear-facing modules (not including corners).

# MOUNTING STRAPS & BRACKETS



MAKE	MODEL	FROM	THROUGH	PART #
Chevrolet	Avalanche	2007	2013	FN-5016
Chevrolet	Caprice	2011	2017	FN-5316
Chevrolet	Colorado / Canyon	2015	2018	FN-5116
Chevrolet	2500 Heavy Duty	2014	2018	FN-5016
Chevrolet	Impala	2014	2018	FN-5316
Chevrolet	Malibu	2012	2016	FN-5316
Chevrolet/GMC	Silverado / Sierra	2014	2018	FN-5316
Chevrolet/GMC	Tahoe / Yukon / Suburban	2007	2014	FN-5016
Chevrolet/GMC	Tahoe / Yukon / Suburban	2015	2018	FN-5316
Chevrolet/GMC	Trailblazer / Envoy	2002	2009	FN-5016
Dodge	Charger	2011	2018	FN-5316
Dodge	Dakota	2005	2011	FN-5116
Dodge	Durango	2011	2018	FN-5116
Dodge	Ram 1500, 2500 & 3500	2012	2018	FN-5316
Ford	Crown Victoria	1998	2012	FN-5216
Ford	Escape	2013	2018	FN-5316
Ford	Excursion	2000	2006	FN-5316
Ford	Expedition	2007	2017	FN-5316
Ford	Expedition	2018	2018	Future
Ford	Explorer / Police Interceptor	2013	2018	FN-5316
Ford	F-150	2015	2018	FN-5316
Ford	F250, F350, F450	1999	2016	FN-5316
Ford	Fusion / Police Hybrid	2013	2019	FN-5316
Ford	Ranger	1998	2011	FN-5016
Ford	Taurus / Police Interceptor	2013	2018	FN-5316
Universal	Universal	N/A	N/A	FN-5316

## UNIVERSAL BRACKETS

	PART #
Headache Rack Mount	FN-9816-M-H*
Permanent Mount	FN-9916-M-P*
Adjustable Foot Mount	FN-9927-AF*
Standard Foot Mount	FN-9716-M-F*

\*Sold in pairs



# HOOK KIT INSTRUCTIONS

## INSTALLING A HOOK BRACKET

- 1) Remove the hex bolt from its packaging and slide the bolt through the hook bracket hole. See figure A.
- 2) Using a socket wrench and the hex bolt, loosely secure the hook bracket to the threaded hole in foot bracket. Repeat on the other side of the lightbar so both sides have the hook bracket secured. See figure B.
- 3) Place the lightbar with the attached hook brackets on the vehicle. Ensure the hook bracket is up right and seated correctly. See figure C.
- 4) Secure and tighten the bracket using a socket wrench on each side of the vehicle until the bar is snugly mounted. Use the included lock nut as a jam nut for extra security. Ensure the vehicle's door will close without any interference.

**⚠** Do not overtighten the hex bolts. Do not exceed 165 in. lb. The use of blue thread locker is suggested.

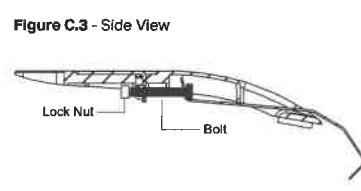
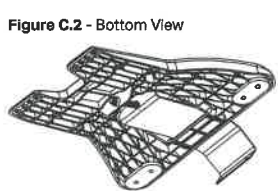
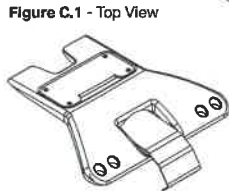
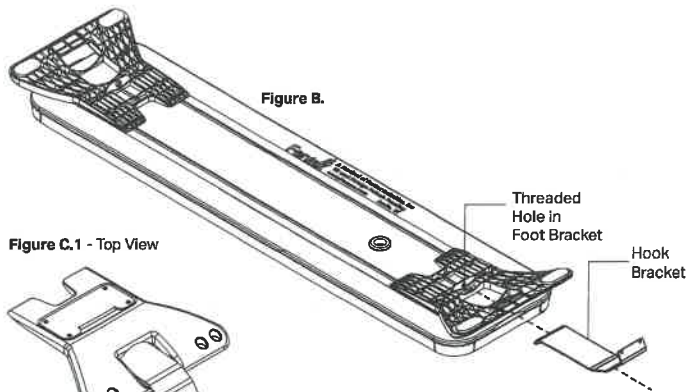
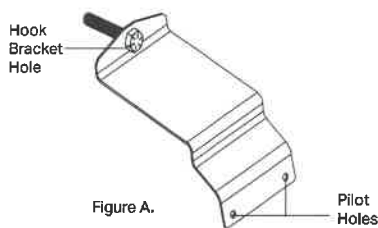

**⚠** Use the "Hook Kit Compatibility Chart" for more information on page 8 of this manual.

- 5) Drill and secure the bracket to the vehicle with self-tapping screws, using the two pilot holes on the bottom of the hook bracket as a guide.
- 6) Once the bar is secure, drill a one inch hole to route the wire harness through the vehicle and then seal the hole with silicone. Ensure that wires are protected from rough edges using a rubber wire grommet.

**⚠** Utilizing non-factory hardware and mounting brackets may result in loss of warranty coverage.

# FUSION LIGHTBAR 60"



IP66

**PART NUMBER: FN-6016**

## KEY FEATURES:

- 360° unobstructed lighting
- 180° or 40° light spread optic available
- Single color: 16 flash patterns
- Dual color: 48 flash patterns
- Available Colors: R, B, A, W, G, RW, BW, AW, AR, AB, RB
- Rugged weather-resistant enclosure
- Capabilities: 3 programmable modes, rear directional, dimming, front and rear cutoff, cruise mode, takedown, alley and work light, flood mode for dual color, optional Stop/Tail/Turn

## QUICK FACTS:

- Made in the USA
- Certifications: SAE J595, CT13, SAE J1113-11
- Available in single color or dual color
- Modern slim line design
- 4 mounting options:
  - Hook kits (multiple vehicle options)
  - Headache Rack
  - Permanent Mount
  - Adjustable foot mount

## SPECIFICATIONS:

Dimensions	1.25" x 60" L x 12.5" W
Warranty	5 years
Cable Harness Length	15 feet

Voltage	12VDC
Current Draw	17A (fuse @125%)
Single Color	180 high power 4 Watt Cree LED's
Dual Color	360 high power 4 Watt Cree LED's

## WIRING DIAGRAM:

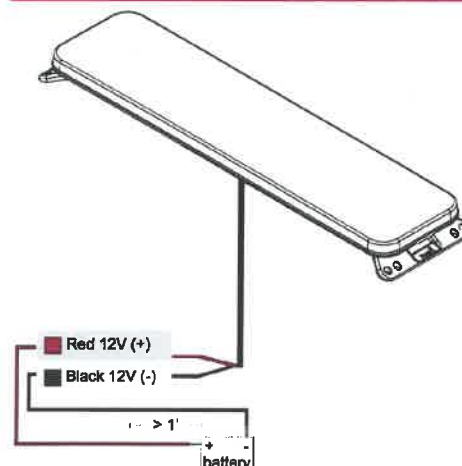

# FUSION<sup>®</sup>

## FUSION 60" LIGHTBAR

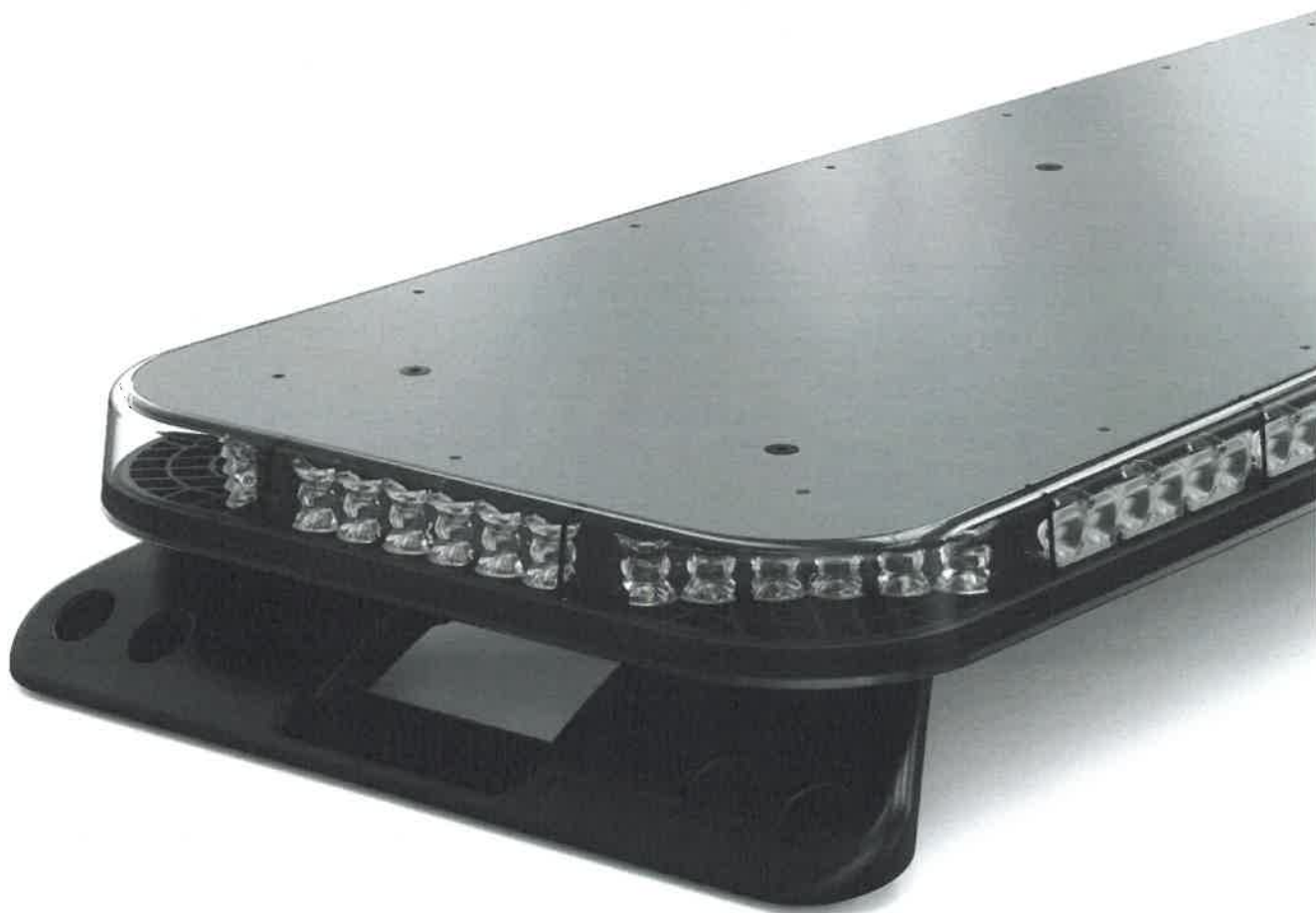

## FN-6016

### INSTRUCTION MANUAL



Fenix Product Copyrights This price List and the mentioned Fenix products include or describe copyrighted Fenix material. Laws in the United States and other countries preserve for Fenix Industries and its licensors certain exclusive rights for copyrighted material, including the exclusive right to copy, reproduce in any form, distribute and make derivative works of the copyrighted material. Accordingly, any copyrighted material of Fenix and its licensors contained herein or in the Fenix products described in this Price List may not be copied, reproduced, distributed, merged or modified, transmitted, transcribed, stored in retrieval system or translated into any language or computer language, in any form or by any means, without prior written permission of Fenix Industries, Inc. Fenix and the stylized Fenix logo are registered in the U.S. Patent & Trademark Office.



# TABLE OF CONTENTS



<b>Safety Regulations &amp; Warranty</b> .....	3
Service after Expiration .....	3
Copyright .....	3
Fenix Product Copyright .....	3
<b>Specifications, Flash Patterns, &amp; Wiring</b> .....	4
Specifications .....	4
Flash Patterns .....	4
Cruise Flash Patterns .....	4
Flood Mode Options .....	4
Box Contents .....	4
Mount Kits .....	4
Equipment Dimensions .....	4
<b>Wiring Diagrams</b> .....	5
Power Connection .....	5
Standard Configuration .....	5
Stop/Tail/Turn & Work Lights .....	5
<b>Wiring Information &amp; Functions</b> .....	6
Power Cable Wiring .....	6
Warning Mode Activation .....	6
Flash Pattern Selection .....	6
Flood Mode Activation .....	6
Flood Mode Selection .....	6
Takedown Activation .....	6
Alley Light Activation .....	6
Cruise Mode Activation .....	6
Cruise Pattern Selection .....	6
Dim Mode Activation .....	6
Arrow Function Activation .....	6
Work Light Activation .....	7
Stop / Tail / Turn Lights .....	7
4200 Datalink Controller .....	7
<b>Mounting Straps &amp; Brackets</b> .....	8
Vehicle Specific Hook Mounts .....	8
Universal Mounts .....	8

# SAFETY REGULATIONS & WARRANTY



## SAFETY REGULATIONS

The following provides all the information necessary to safely operate the previously listed products of Feniex Industries, Inc. Please read this manual thoroughly before installing or operating your new product in order to prevent any damage or injury. Failure to follow the listed instructions in this manual may result in damage to your products or personal injury.

- Proper installation of this product requires good knowledge of automotive systems, electronics & procedures.
- Please guarantee all vital components of the vehicle are not in danger of being damaged by drilling holes necessary for installation. Check all sides of the mounting surface before drilling any holes into the vehicle.
- Do not install this product in any way that interferes with the deployment of the air bag. Doing so may damage the effectiveness of the air bag & can lead to serious personal and vehicle injury. The installer will assume full responsibility of proper installation of the new unit.
- Please clean the mounting surface before installation of the unit when using tape, brackets, magnet, Velcro or suction cups.
- The product's ground wire must be connected directly to the negative (-) battery post for effective use of the unit. Please follow all wiring guidelines provided to guarantee long lifespan & productivity. Failing to follow these instructions may result in damage to the product.

## WARRANTY

Feniex Industries, Inc. warrants to the original purchaser that the product shall be free from defects in material & workmanship for 5 years from the date of purchase for all LED products. Feniex Industries warranties speakers, sirens, flashers, & controllers for 2 years.

If warranty service is needed, please contact customer support:

**Phone:** 1.800.615.8350

**Web Site:** [www.Feniex.com/support](http://www.Feniex.com/support)

**Email:** [techsupport@feniex.com](mailto:techsupport@feniex.com)

If the product needs to be returned for repair or replacement, contact our customer service team (using any method listed above) to receive a Return Merchandise Authorization (RMA) number. Operational times are from 9 a.m. to 6 p.m. central time, Monday through Friday.



Please do not send in product without contacting support first for a Return Merchandise Authorization (RMA) number.

## CONDITIONS

Feniex Industries, Inc. will not be held responsible for any costs associated with equipment removal and/or re-installation resulting from a warranty claim. It is the sole responsibility of the party initiating a warranty claim to pay shipping charges associated with returning a product to Feniex Industries for repair or replacement.

## SERVICE AFTER EXPIRATION

Feniex Industries will still provide service for all products after expiration of the warranty. For any issues, call the customer support line. In some instances it may be necessary for the product to be shipped, freight prepaid and insured for loss or damage to Feniex headquarters.



Utilizing non-factory screws and mounting brackets may result in the loss of warranty coverage.

## COPYRIGHT

This instruction manual and the Feniex products described in this instruction manual may include or describe copyrighted Feniex material. Laws in the United States and other countries preserve for Feniex Industries and its licensors certain exclusive rights for copyrighted material, including the exclusive right to copy, reproduce in any form, distribute and make derivative works of the copyrighted material. Accordingly, any copyrighted material of Feniex and its licensors contained herein or in the Feniex products described in this instruction manual may not be copied, reproduced, distributed, merged or modified in any manner without the express written permission of Feniex Industries, Inc.

## FENIEX PRODUCT COPYRIGHTS

The products described in this document are the property of Feniex Industries, Inc. It is furnished by express license agreement only and may be used only in accordance with the terms of such an agreement. Products and documentation are copyrighted materials. Making unauthorized copies is prohibited by law. No part of the product or documentation may be reproduced, transmitted, transcribed, stored in retrieval system or translated into any language or computer language, in any form or by any means, without prior permission from Feniex Industries, Inc.

# SPECIFICATIONS, PATTERNS, & WIRING



## SYSTEM SPECIFICATIONS

Input Power	10-18 VDC
Current Draw	15 Amps
External Fuse	125% of Circuit Load
Cable	15 Feet
Colors	Amber, Red, Blue, White, Green
SAE Certification	Class 1, J595, CT13, J1113-11
Flash Patterns	18 Single Color, 52 Dual Color
LED Technology	Cree, 4 Watt
Dimensions	59.5" L x 1.6" H x 11.8" W (no bracket)
Warranty	5 Years

## FLOOD MODE OPTIONS

- 1) Front Modules
- 2) Front & Side Modules (excluding alley)
- 3) Front, Side (excluding alley), & Rear/Arrow Modules
- 4) Side & Rear/Arrow Modules
- 5) Rear/Arrow Modules

## BOX CONTENTS

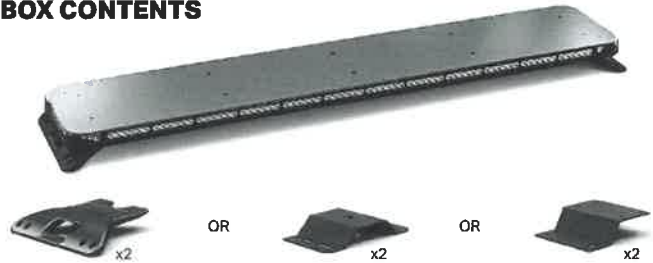

BOX CONTENTS	QUANTITY
1. Fusion 60"	1
2. Standard Foot Mount	2*

\*Permanent or Headache Rack Mounts may be substituted at time of purchase

## FLASH PATTERNS

- |                           |                           |
|---------------------------|---------------------------|
| 1) Cluster Pattern        | Single & Dual Color Modes |
| 2) Attack Pattern         | Single & Dual Color Modes |
| 3) Night Ride Pattern     | Single & Dual Color Modes |
| 4) Half-Half [Slow]       | Single & Dual Color Modes |
| 5) Half-Half [Fast]       | Single & Dual Color Modes |
| 6) One-One [Slow]         | Single & Dual Color Modes |
| 7) One-One [Fast]         | Single & Dual Color Modes |
| 8) Two-Two [Slow]         | Single & Dual Color Modes |
| 9) Two -Two [Fast]        | Single & Dual Color Modes |
| 10) All-On [Slow]         | Single & Dual Color Modes |
| 11) All-On [Fast]         | Single & Dual Color Modes |
| 12) In-Out [Slow]         | Single & Dual Color Modes |
| 13) In-Out [Fast]         | Single & Dual Color Modes |
| 14) Combo: All Slow       | Single & Dual Color Modes |
| 15) Combo: All Fast       | Single & Dual Color Modes |
| 16) Combo: Fast & Slow    | Single & Dual Color Modes |
| 17) Quad Flash: Half-Half | Single & Dual Color Modes |
| 18) Quad Flash: In-Out    | Single & Dual Color Modes |

MOUNT KITS*	PART NUMBER
Standard Foot Mount	FN-9716-M-F*
Permanent Mount	FN-9916-M-P*
Headache Rack Mount	FN-9816-M-H*
Adjustable Foot Mount	FN-9927-AF*

\*Sold Separately, in pairs

## CRUISE FLASH PATTERNS

- 1) All On
- 2) Single Flash [Slow], Simultaneous
- 3) Single Flash [Flash], Simultaneous
- 4) Single Flash [Slow], Alternating
- 5) Single Flash [Flash], Alternating
- 6) Single Flash [Slow], Corners, Alternating
- 7) Single Flash [Fast], Corners, Alternating
- 8) Attack Pattern

**⚠** See page 8 for a full list of available vehicle specific light bar strap kits.

## DIMENSIONS

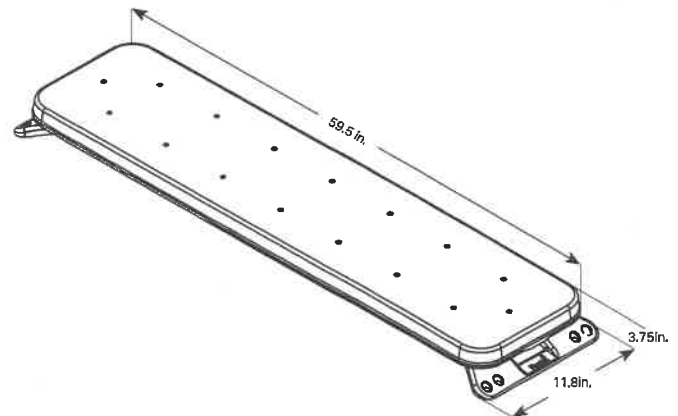



# WIRING DIAGRAMS

## WIRING DIAGRAM: POWER CONNECTIONS

Wire Color	Function	Polarity	Description
■ Black	Ground	12v (-)	Connect to vehicle's negative battery post
■ Red	Positive	12v (+)	Connect to vehicle's positive battery post

All user-supplied wires connecting to 12v (+) or 12v (-) must be sized to supply 100% of the maximum current and properly fused at the power source with a fuse rated at 125% of the total circuit load. Avoid routing wires in the deployment area of the vehicle air bag or any other potentially hazardous locations.

## WIRING DIAGRAM: STANDARD CONFIGURATION

Wire Color	Function	Polarity	Description
■ Green/White	Mode 0 Rear	12v (+)	Activates rear-facing modules, corners, & sides
■ Blue/White	Mode 0 Front	12v (+)	Activates front-facing modules & corners
■ Black	Mode 1	12v (+)	Warning Mode 1 [Overrides Mode 0]
■ Red	Mode 2	12v (+)	Warning Mode 2 [Overrides Mode 0 & 1]
■ Orange	Mode 3	12v (+)	Warning Mode 3 [Overrides Modes 0, 1 & 2]
■ Green	Cruise Mode	12v (+)	Corner Modules [10% Brightness]
■ Blue	Takedown	12v (+)	Overrides Modes 1, 2, & 3 Flash Patterns
■ Red/Black	Left Alley	12v (+)	Steady Burn [Overrides Flashing]
□ White	Right Alley	12v (+)	Steady Burn [Overrides Flashing]
■ Orange/Black	Flashing TD/Alley	12v (+)	Flashes Takedown & Alley Lights
■ Green/Black	Flood Mode	12v (+)	Activates Flood Mode [if dual color, if configured]
■ Blue/Black	Dim	12v (+)	Dims Lightbar [Takedown, Alley, & Flood Unaffected]
■ White/Black	Arrow Left	12v (+)	Left Arrow [Overrides Flashing]
■ Black/White	Arrow Right	12v (+)	Right Arrow [Overrides Flashing]
■ Wht/Blk + ■ Blk/Wht	Center Out	12v (+)	Center-Out Arrow [Overrides Flashing]
■ Red/White	Pattern Changer	12v (+)	Momentary, cycles through flash patterns

When Mode 1 Front or Mode 1 Rear is active, the side positions will not activate. If both Mode 0 Front and Rear are active or Modes 2 or 3 are active, the side positions will activate (if not configured as alley positions).

## WIRING DIAGRAM: STOP/TAIL/TURN & WORK LIGHTS

Wire Color	Function	Polarity	Description
■ Orange	Tail Lights	12v (+)	Steady Burn of both tail lights [10% Brightness]
■ Red	Work Lights	12v (+)	Steady Burn
■ Green	Left Brake/Turn	12v (+)	[Overrides Tail Light]
■ Blue/Black	Right Brake/Turn	12v (+)	[Overrides Tail Light]

\*All other activation wires retain original function

# WIRING INFORMATION & FUNCTIONS

## POWER CABLE WIRING











- 1) Install a customer-supplied fuse rated for 125% of the circuit load to the end of the red wire. Do not use a circuit breaker or fusible link.
- 2) Connect the opposite end of the fuse to the 12v+ terminal of the battery. Do not use more than 1 foot of wire between the fuse and the battery terminal to ensure appropriate protection.
- 3) Connect the black wire to the vehicle chassis ground.
- 4) Connect the function wires to switches, depending on the functions needed for applications (See page 6 for wiring diagrams).

## WARNING MODES

Activate the warning modes by extending the blue/white (front) and green/white (rear) wires to 12v (+) latching switches to activate mode 0 (front and/or rear as desired). When power is supplied to mode 1 (black), the pattern will be changed for the active display. When power is supplied to mode 2 (red) or mode 3 (orange) wires, the selected pattern for each mode will display on the whole bar (front and rear).

 If Mode 0 front and/or Mode 0 rear isn't active, Mode 1 will not function. Mode 1 only overrides an active Mode 0 function.

Example:

-  = Mode 0, Rear
-  +  = Mode 1 Pattern, Rear Only
-  +  = Mode 0, Front & Rear
-  +  = Mode 1 Pattern, Front Only
-  +  +  = Mode 1 Pattern, Front & Rear

Effectively, 4 patterns can be displayed in any variation of single and/or dual colors (if configured as a dual color lightbar). Patterns for front and rear (Modes 0 & 1) will always match, patterns cannot be split (front to rear) in any mode.

## FLASH PATTERNS

Advance the pattern by extending the red/white wire to a 12v (+) momentary switch or tap the red/white wire to a 12v (+) terminal for 1 second.

 Mode 0 activates front & rear independently, Mode 1 overrides the current pattern of the active Mode 0 display, Mode 2 & 3 activate both front and rear, with Mode 3 overriding all modes.

 A different pattern can be set for each of the four modes. The pattern will only be changed for the active pattern.

## FLOOD MODE

Activate flood mode by extending the green/black wire to a 12v (+) latching switch.

## FLOOD MODE SELECTION

Activate flood mode and use the red/white pattern change wire to select the desired flood mode.

## TAKEDOWN

Activate the factory configured takedown function by extending the blue wire to a 12v (+) latching switch.

## ALLEY LIGHTS

Activate the factory configured alley lights by extending the red/black & white wires to 12v (+) latching switches.

 Takedown & alley functionality must be specified at time of order. Modules in takedown and/or alley positions will only function as such, or flashing takedown/alley. No warning patterns will be displayed in takedown or alley positions.

## TAKEDOWN & ALLEY FLASHING

Activate the factory configured takedown flashing function by extending the green wire to a 12v (+) latching switch. For dual color models, warning mode 2 will be activated instead of the flashing takedown function.

## CRUISE MODE

Activate Cruise Mode by extending the green wire to a 12v (+) latching switch or mode wire. Rotate through the different dim modes by tapping the pattern change wire.

## CRUISE PATTERN SELECTION

- 1) Apply 12v (+) to the cruise mode wire (green).
- 2) Apply 12v (+) (momentary) to the red/white wire to advance the pattern of the cruise mode.

## DIM MODE

Activate the flash mode by applying the flashmode wire to a 12V(+). Activate Dim Mode by extending the blue/black wire to a 12v (+). Tap the pattern changer, red/white wire to cycle through the dim modes.

 Dim Mode is only available on hard-wire models. This mode will dim all modes except for Takedown functions & Flood Mode.

## ARROW FUNCTIONS

Activate the arrow functions by extending the white/black wire, black/white wire, or a combination of both to 12v (+) latching switches.

 Arrow functions will override all warning modes on all rear-facing modules (not including corners).

## WIRING INFORMATION & FUNCTIONS



Work Light and Stop/Tail/Turn functionality must be specified at time of order. Modules in work light and/or STT positions will only function as such. No warning patterns will be displayed in work light or STT positions.

### WORK LIGHTS

If equipped, activate the factory configured work lights by extending the red wire (Mode 2) to a 12v (+) latching switch.



If work light functionality is specified at time of order, it will replace Mode 2 functionality.

### STOP/TAIL/TURN

If equipped, activate the factory configured Stop/Tail/Turn by extending the following wires:

- 1) Orange wire to the taillight circuit
- 2) Green wire to the left brake/turn circuit
- 3) Blue/Black wire to the right brake/turn circuit



If Stop/Tail/Turn functionality is specified at time of order, it will replace Mode 3, Cruise, & Dim functions.

---

### 4200 DATALINK CONTROLLER



When using data link connect the RJ-45 connection to the 4200 Relay. Use the 4200 Software to program the desired function of the Fusion 60" lightbar.



When the RJ-45 Data Link wire is connected to the 4200 Relay this will override any other wire input to the Fusion 60" Lightbar. You can either use Data Link or the discrete wires, but not both.

# MOUNTING STRAPS & BRACKETS



FN-5316



FN-5216



FN-5116



FN-5016



FN-5416



FN-5019

MAKE	MODEL	FROM	THROUGH	PART #
Chevrolet	Avalanche	2007	2013	FN-5016
Chevrolet	Caprice	2011	2017	FN-5316
Chevrolet	Colorado / Canyon	2015	2018	FN-5116
Chevrolet	2500 Heavy Duty	2014	2018	FN-5016
Chevrolet	Impala	2014	2018	FN-5316
Chevrolet	Malibu	2012	2016	FN-5316
Chevrolet/GMC	Silverado / Sierra	2014	2018	FN-5316
Chevrolet/GMC	Tahoe / Yukon / Suburban	2007	2014	FN-5016
Chevrolet/GMC	Tahoe / Yukon / Suburban	2015	2018	FN-5316
Chevrolet/GMC	Trailblazer / Envoy	2002	2009	FN-5016
Dodge	Charger	2011	2018	FN-5316
Dodge	Dakota	2005	2011	FN-5116
Dodge	Durango	2011	2018	FN-5116
Dodge	Ram 1500, 2500 & 3500	2012	2018	FN-5316
Ford	Crown Victoria	1998	2012	FN-5216
Ford	Escape	2013	2018	FN-5316
Ford	Excursion	2000	2006	FN-5316
Ford	Expedition	2007	2017	FN-5316
Ford	Explorer / Police Interceptor	2013	2018	FN-5316
Ford	F-150	2015	2018	FN-5316
Ford	F250, F350, F450	1999	2016	FN-5316
Ford	Fusion / Police Hybrid	2013	2019	FN-5316
Ford	Ranger	1998	2011	FN-5016
Ford	Taurus / Police Interceptor	2013	2018	FN-5316
Dodge	Durango	2011	2019	FN-5416
Ford	Police Interceptor Utility	2020	N/A	FN-5019
Universal	Universal	N/A	N/A	FN-5316

## UNIVERSAL BRACKETS

	PART #
Headache Rack Mount	FN-9816-M-H*
Permanent Mount	FN-9916-M-P*
Adjustable Foot Mount	FN-9927-AF*
Standard Foot Mount	FN-9716-M-F*

\*Sold in pairs



FN-9927-AF



FN-9716-M-F



FN-9816-M-H



FN-9916-M-P

# HOOK KIT INSTRUCTIONS

## INSTALLING A HOOK BRACKET

- 1) Remove the hex bolt from its packaging and slide the bolt through the hook bracket hole. See figure A.
- 2) Using a socket wrench and the hex bolt, loosely secure the hook bracket to the threaded hole in foot bracket. Repeat on the other side of the lightbar so both sides have the hook bracket secured. See figure B.
- 3) Place the lightbar with the attached hook brackets on the vehicle. Ensure the hook bracket is up right and seated correctly. See figure C.
- 4) Secure and tighten the bracket using a socket wrench on each side of the vehicle until the bar is snugly mounted. Use the included lock nut as a jam nut for extra security. Ensure the vehicle's door will close without any interference.

**⚠** Do not overtighten the hex bolts. Do not exceed 165 in. lb. The use of blue thread locker is suggested.

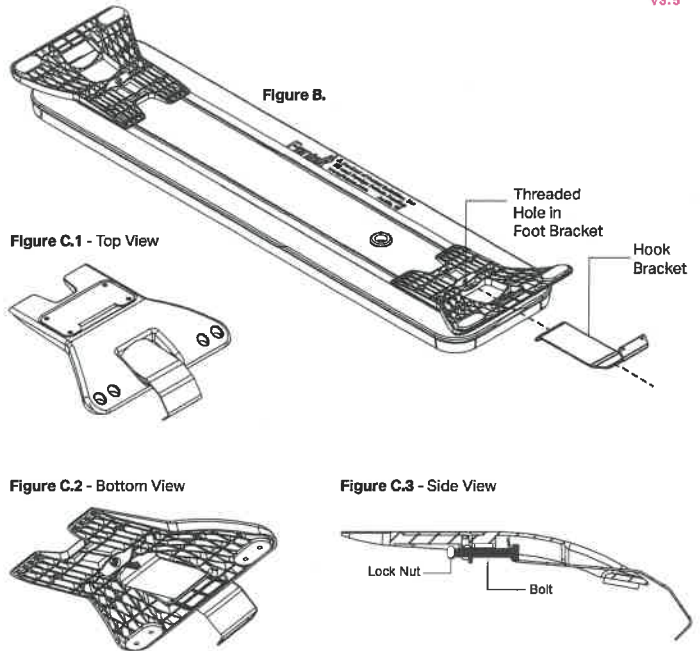
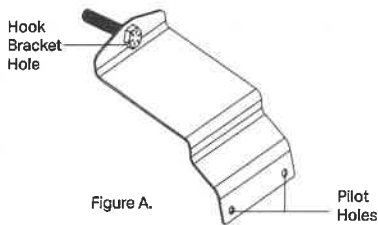

**⚠** Use the "Hook Kit Compatibility Chart" for more information on page 8 of this manual.

- 5) Drill and secure the bracket to the vehicle with self-tapping screws, using the two pilot holes on the bottom of the hook bracket as a guide.
- 6) Once the bar is secure, drill a one inch hole to route the wire harness through the vehicle and then seal the hole with silicone. Ensure that wires are protected from rough edges using a rubber wire grommet.

**⚠** Utilizing non-factory hardware and mounting brackets may result in loss of warranty coverage.

# FUSION SURFACE MOUNT



**PART NUMBER: FSM-40/180-\*\***

## KEY FEATURES:

- Available in 180° or 40° light spread optics
- Single color: 11 flash patterns
- Dual color: 40 flash patterns
- 2 programmable modes, flood pattern capable for dual color
- Ultra-rugged metal housing
- Available Colors: R, B, A, W, G, RW, BW, AW, AR, AB, RB
- Available brake, turn and steady on patterns
- Includes surface mount bezel and protective, rubber mounting pad

## QUICK FACTS:

- Made in the USA
- Certifications: SAE J595, CT13, SAE J1113-11
- Available in single color or dual color
- Syncs with: - Fusion 1X & 2X
  - Fusion Mirror & Spoiler Mounts
  - Fusion 200
  - Cannon, T3, & Wide-Lux
- 4 bracket options: Rotating, License-plate, Single L-Bracket, Double L-Bracket

## SPECIFICATIONS:

Dimensions	1.17" H x 5.22" L x 0.88" W
Warranty	5 years
Cable Harness Length	10 inches

Voltage	12VDC
Current Draw	0.75A (fuse @ 125%)
Single Color	6 high power 4 Watt Cree LED's
Dual Color	12 high power 4 Watt Cree LED's

## WIRING DIAGRAM:

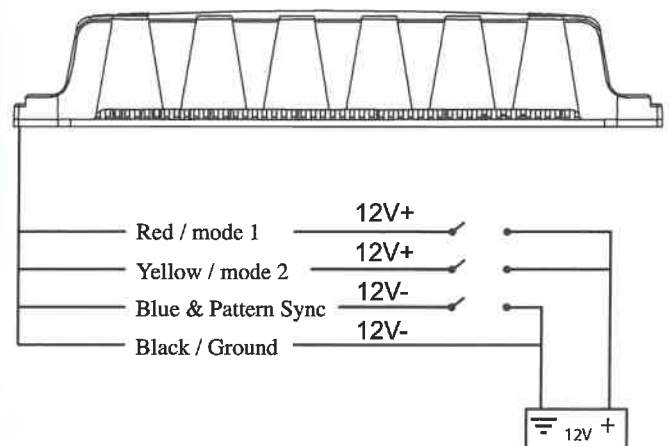

## Light spread:

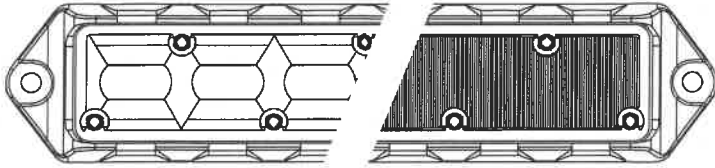

180° Light spread

40° Light spread

## Color Specifications:

- A     R     B     W     G  
 RW    BW    AW    RB    AR    AB

## Dual color patterns

Color 1- Single Slow
Color 1- Single Fast
Color 1- Single Combo
Color 1- Double Slow
Color 1- Double Fast
Color 1- Double Combo
Color 1- Triple Slow
Color 1- Triple Fast
Color 1- Triple Combo
Color 2- Single Slow
Color 2- Single Fast
Color 2- Single Combo
Color 2- Double Slow
Color 2- Double Fast
Color 2- Double Combo
Color 2- Triple Slow
Color 2- Triple Fast
Color 2- Triple Combo
Color 1&2 / No Off Time- Single Slow
Color 1&2 / No Off Time- Single Fast
Color 1&2 / No Off Time- Single Combo
Color 1&2 / No Off Time- Double Slow
Color 1&2 / No Off Time- Double Fast
Color 1&2 / No Off Time- Double Combo
Color 1&2 / No Off Time- Triple Slow
Color 1&2 / No Off Time- Triple Fast
Color 1&2 / No Off Time- Triple Combo
Color 1&2 / Off Time- Single Slow
Color 1&2 / Off Time- Single Fast
Color 1&2 / Off Time- Single Combo
Color 1&2 / Off Time- Double Slow

Color 1&2 /Off Time- Double Fast
Color 1&2 /Off Time- Double Combo
Color 1&2 /Off Time- Triple Slow
Color 1&2 /Off Time- Triple Fast
Color 1&2 /Off Time- Triple Combo
Color 1- Brake Pop
Color 2- Brake Pop
Color 1- Steady On
Color 2- Steady On

## Single color patterns

Single Slow
Single Fast
Single Combo
Double Slow
Double Fast
Double Combo
Triple Slow
Triple Fast
Triple Combo
Brake Pop
Steady On

## Wiring Diagram and Instructions:

1. To activate the unit, extend the red (+) or yellow (+) wire to a 12V post. Extend the black (-) wire to the ground post of the vehicle's battery. Please note that mode 2 overrides mode 1.

2. Momentarily connect the blue wire to the Ground (12V-) to cycle through the flash patterns.

3. Synchronization: To Sync two or more light heads together:

A. Apply 12V+ power to the red or yellow (+) wire and apply 12V- to black wire to power the unit on.

B. Cycle through all patterns by tapping the blue (flash pattern changer) wire to the activated black ground wire until the steady burn pattern is selected.

C. Connect one of the same colored mode wires (red or yellow) of the two light heads together; connect the black wires of the light heads together and then connect the blue wires of the light heads together.

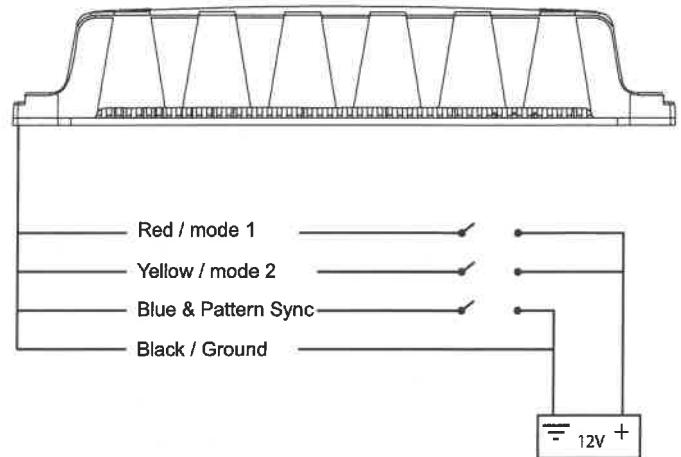

## Alternate Light Heads:

D. Follow steps A-B.

E. For the light heads to alternate, one light head must be set as master and the other as slave on the mode wire intended for use. To do so, hold the blue (flash pattern changer) wire to ground for 3 seconds.

If all LEDs turn on, this indicates master mode. If no LEDs turn on, this indicates slave mode.

F. Follow step C. Change patterns by tapping the blue wire to the activated black ground wire.

# FUSION SURFACE MOUNT



**PART NUMBER: FSM-40/180-\*\***

## KEY FEATURES:

- Available in 180° or 40° light spread optics
- Single color: 11 flash patterns
- Dual color: 40 flash patterns
- 2 programmable modes, flood pattern capable for dual color
- Ultra-rugged metal housing
- Available Colors: R, B, A, W, G, RW, BW, AW, AR, AB, RB
- Available brake, turn and steady on patterns
- Includes surface mount bezel and protective, rubber mounting pad

## QUICK FACTS:

- Made in the USA
- Certifications: SAE J595, CT13, SAE J1113-11
- Available in single color or dual color
- Syncs with: - Fusion 1X & 2X
  - Fusion Mirror & Spoiler Mounts
  - Fusion 200
  - Cannon, T3, & Wide-Lux
- 4 bracket options: Rotating, License-plate, Single L-Bracket, Double L-Bracket

## SPECIFICATIONS:

Dimensions	1.17" H x 5.22" L x 0.88" W
Warranty	5 years
Cable Harness Length	10 inches

Voltage	12VDC
Current Draw	0.75A (fuse @ 125%)
Single Color	6 high power 4 Watt Cree LED's
Dual Color	12 high power 4 Watt Cree LED's

## WIRING DIAGRAM:

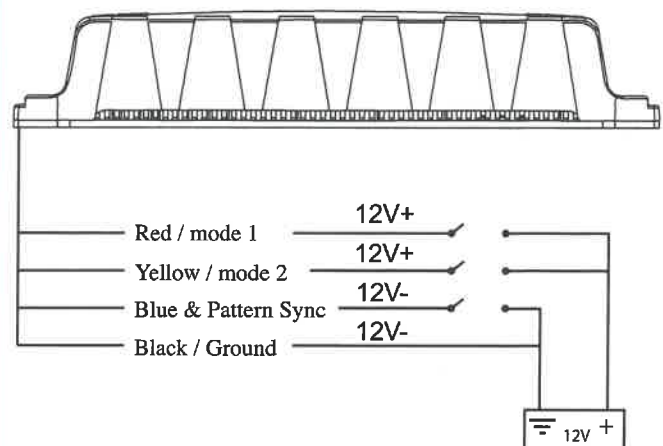



## Light spread:

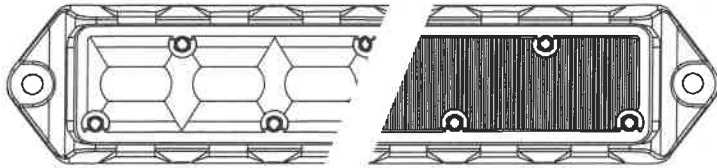

180° Light spread

40° Light spread

## Color Specifications:

- A     R     B     W     G  
 RW    BW    AW    RB    AR    AB

## Dual color patterns

Color 1- Single Slow
Color 1- Single Fast
Color 1- Single Combo
Color 1- Double Slow
Color 1- Double Fast
Color 1- Double Combo
Color 1- Triple Slow
Color 1- Triple Fast
Color 1- Triple Combo
Color 2- Single Slow
Color 2- Single Fast
Color 2- Single Combo
Color 2- Double Slow
Color 2- Double Fast
Color 2- Double Combo
Color 2- Triple Slow
Color 2- Triple Fast
Color 2- Triple Combo
Color 1&2 / No Off Time- Single Slow
Color 1&2 / No Off Time- Single Fast
Color 1&2 / No Off Time- Single Combo
Color 1&2 / No Off Time- Double Slow
Color 1&2 / No Off Time- Double Fast
Color 1&2 / No Off Time- Double Combo
Color 1&2 / No Off Time- Triple Slow
Color 1&2 / No Off Time- Triple Fast
Color 1&2 / No Off Time- Triple Combo
Color 1&2 /Off Time- Single Slow
Color 1&2 /Off Time- Single Fast
Color 1&2 /Off Time- Single Combo
Color 1&2 /Off Time- Double Slow

Color 1&2 /Off Time- Double Fast
Color 1&2 /Off Time- Double Combo
Color 1&2 /Off Time- Triple Slow
Color 1&2 /Off Time- Triple Fast
Color 1&2 /Off Time- Triple Combo
Color 1- Brake Pop
Color 2- Brake Pop
Color 1- Steady On
Color 2- Steady On

## Single color patterns

Single Slow
Single Fast
Single Combo
Double Slow
Double Fast
Double Combo
Triple Slow
Triple Fast
Triple Combo
Brake Pop
Steady On

## Wiring Diagram and Instructions:

1. To activate the unit, extend the red (+) or yellow (+) wire to a 12V post. Extend the black (-) wire to the ground post of the vehicle's battery. Please note that mode 2 overrides mode 1.

2. Momentarily connect the blue wire to the Ground (12V-) to cycle through the flash patterns.

3. Synchronization: To Sync two or more light heads together:

A. Apply 12V+ power to the red or yellow (+) wire and apply 12V- to black wire to power the unit on.

B. Cycle through all patterns by tapping the blue (flash pattern changer) wire to the activated black ground wire until the steady burn pattern is selected.

C. Connect one of the same colored mode wires (red or yellow) of the two light heads together; connect the black wires of the light heads together and then connect the blue wires of the light heads together.

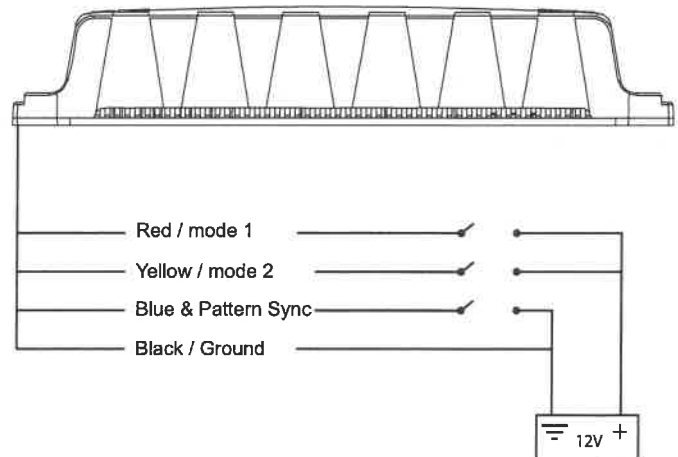

## Alternate Light Heads:

D. Follow steps A-B.

E. For the light heads to alternate, one light head must be set as master and the other as slave on the mode wire intended for use. To do so, hold the blue (flash pattern changer) wire to ground for 3 seconds.

If all LEDs turn on, this indicates master mode. If no LEDs turn on, this indicates slave mode.

F. Follow step C. Change patterns by tapping the blue wire to the activated black ground wire.

# T3 SURFACE MOUNT

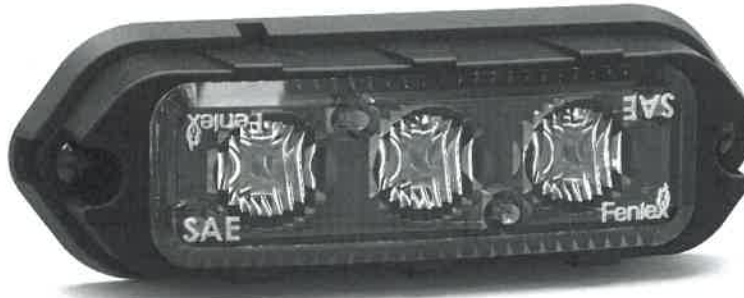

**PART NUMBER: D-50015**

## KEY FEATURES:

- 40° degree light spread
- Available brake, tail and steady on patterns
- Available colors: R, A, B, W, G
- Integrated mounting bezel with rubber mounting protective pad
- 4 bracket options: Rotating, License Plate, Single L-Bracket, Double L-Bracket
- Rugged weather-resistant enclosure

## QUICK FACTS:

- Made in the USA
- Certifications: SAE J595, SAE J1113-11, CT13
- Stands out as the brightest and most cost-effective option in the emergency warning industry
- Mount anywhere on vehicle
- 3x 4-Watt LEDs

## SPECIFICATIONS:

Dimensions	1" W x 3.4" L x 1.05" H
Warranty	5 years
Cable Harness Length	10 inches
Voltage	12VDC
Current Draw	0.75 mA (fuse @125%)

## WIRING DIAGRAM:

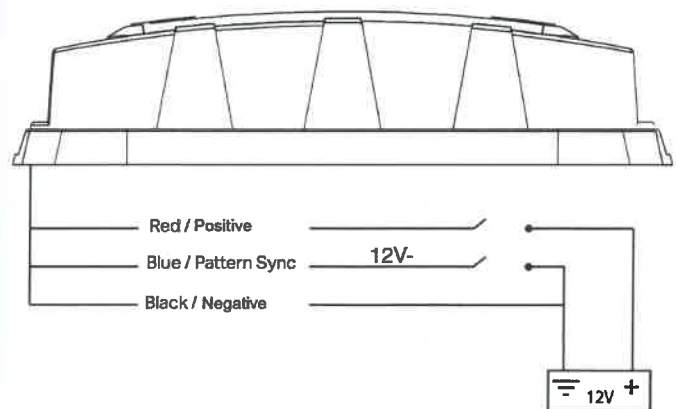



# T3®

## FIERCELY BRIGHT

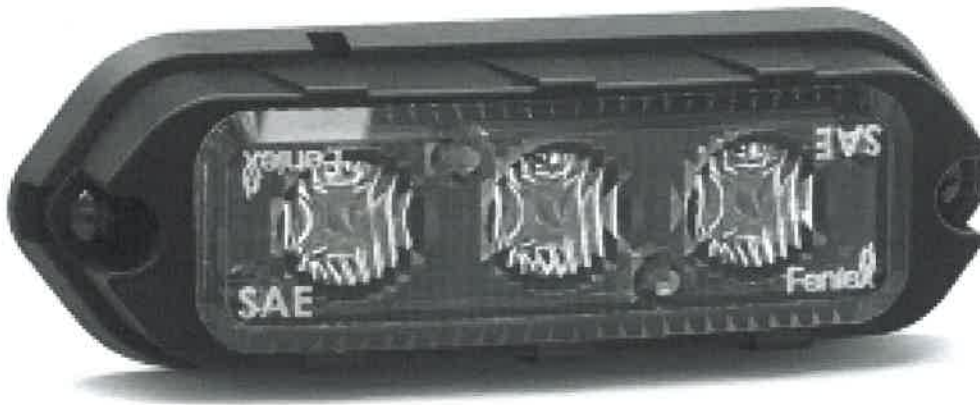

### D-50015

# INSTRUCTION MANUAL



Fenix Product Copyrights This price List and the mentioned Fenix products include or describe copyrighted Fenix material. Laws in the United States and other countries preserve for Fenix industries and its licensors certain exclusive rights for copyrighted material, including the exclusive right to copy, reproduce in any form, distribute and make derivative works of the copyrighted material. Accordingly, any copyrighted material of Fenix and its licensors contained herein or in the Fenix products described in this Price List may not be copied, reproduced, distributed, merged or modified, transmitted, transcribed, stored in retrieval system or translated into any language or computer language, in any form or by any means, without prior written permission of Fenix Industries, Inc. Fenix and the stylized Fenix logo are registered in the U.S. Patent & Trademark Office.



# TABLE OF CONTENTS



<b>Safety Regulations &amp; Warranty</b> .....	3
Service after Expiration .....	3
Copyright .....	3
Fenix Product Copyright .....	3
<b>Box Contents, Specifications, &amp; Dimensions</b> .....	4
Box Contents .....	4
Flash Patterns .....	4
Specifications .....	4
Dimensions .....	4
<b>Configuration &amp; Mounting</b> .....	5
Wiring Diagram .....	5
Power .....	5
Setting Master/Slave .....	5
Patterns & Synchronization .....	5
<b>Mounting Instructions</b> .....	6

## SAFETY REGULATIONS & WARRANTY

### SAFETY REGULATIONS

The following provides all the information necessary to safely operate the previously listed products of Feniex Industries, Inc. Please read this manual thoroughly before installing or operating your new product in order to prevent any damage or injury. Failure to follow the listed instructions in this manual may result in damage to your products or personal injury.

- Proper installation of this product requires good knowledge of automotive systems, electronics & procedures.
- Please guarantee all vital components of the vehicle are not in danger of being damaged by drilling holes necessary for installation. Check all sides of the mounting surface before drilling any holes into the vehicle.
- Do not install this product in any way that interferes with the deployment of the air bag. Doing so may damage the effectiveness of the air bag & can lead to serious personal and vehicle injury. The installer will assume full responsibility of proper installation of the new unit.
- Please clean the mounting surface before installation of the unit when using tape, brackets, magnet, Velcro or suction cups.
- The product's ground wire must be connected directly to the negative (-) battery post for effective use of the unit. Please follow all wiring guidelines provided to guarantee long lifespan & productivity. Failing to follow these instructions may result in damage to the product.

### WARRANTY

Feniex Industries, Inc. warrants to the original purchaser that the product shall be free from defects in material & workmanship for 5 years from the date of purchase for all LED products. Feniex Industries warranties speakers, sirens, flashers, & controllers for 2 years.

If warranty service is needed, please contact customer support:

**Phone:** 1.800.615.8350

**Web Site:** [www.Feniex.com/support](http://www.Feniex.com/support)

**Email:** [techsupport@feniex.com](mailto:techsupport@feniex.com)

If the product needs to be returned for repair or replacement, contact our customer service team (using any method listed above) to receive a Return Merchandise Authorization (RMA) number. Operational times are from 9 a.m. to 6 p.m. central time, Monday through Friday.



Please do not send in product without contacting support first for a Return Merchandise Authorization (RMA) number.

### CONDITIONS

Feniex Industries, Inc. will not be held responsible for any costs associated with equipment removal and/or re-installation resulting from a warranty claim. It is the sole responsibility of the party initiating a warranty claim to pay shipping charges associated with returning a product to Feniex Industries for repair or replacement.

### SERVICE AFTER EXPIRATION

Feniex Industries will still provide service for all products after expiration of the warranty. For any issues, call the customer support line. In some instances it may be necessary for the product to be shipped, freight prepaid and insured for loss or damage to Feniex headquarters.



Utilizing non-factory screws and mounting brackets may result in the loss of warranty coverage.

### COPYRIGHT

This instruction manual and the Feniex products described in this instruction manual may include or describe copyrighted Feniex material. Laws in the United States and other countries preserve for Feniex Industries and its licensors certain exclusive rights for copyrighted material, including the exclusive right to copy, reproduce in any form, distribute and make derivative works of the copyrighted material. Accordingly, any copyrighted material of Feniex and its licensors contained herein or in the Feniex products described in this instruction manual may not be copied, reproduced, distributed, merged or modified in any manner without the express written permission of Feniex Industries, Inc.

### FENIEX PRODUCT COPYRIGHTS

The products described in this document are the property of Feniex Industries, Inc. It is furnished by express license agreement only and may be used only in accordance with the terms of such an agreement. Products and documentation are copyrighted materials. Making unauthorized copies is prohibited by law. No part of the product or documentation may be reproduced, transmitted, transcribed, stored in retrieval system or translated into any language or computer language, in any form or by any means, without prior permission from Feniex Industries, Inc.

# BOX CONTENTS, SPECIFICATIONS, DIMENSIONS, & PATTERNS



## BOX CONTENTS

COMPONENTS	QUANTITY
T3	1
Rubber Pad	1
Screws	2

## SYSTEM SPECIFICATIONS

Input Power	12 VDC
Current Draw	0.75 Amps
External Fuse	125% of Circuit Load
Colors	Amber, Red, Blue, White, Green
SAE Certification	J595, CT13, SAE J1113-11
Flash Patterns	14
Dimensions	1.05" H x 3.4" L x 1" W
Warranty	5 Years

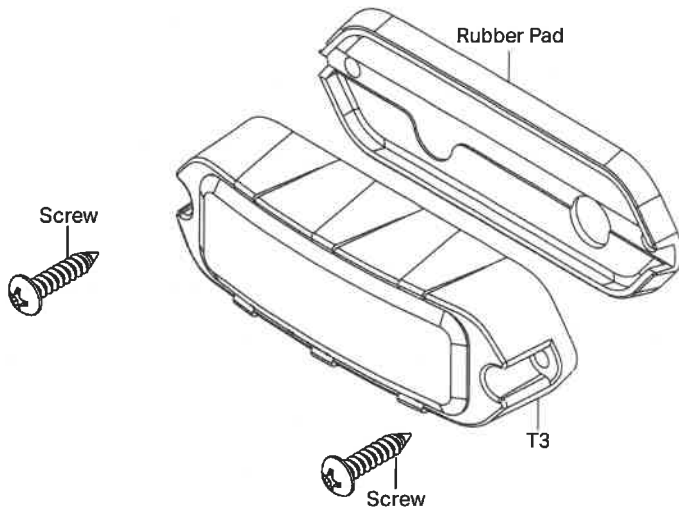

## FLASH PATTERNS

Single Flash [Slow]	Quad Flash [Fast]
Single Flash [Fast]	Quad Flash [Combo]
Single Flash [Combo]	Attack #1
Double Flash [Slow]	Attack #2
Double Flash [Fast]	Steady On [3 Seconds]
Double Flash [Combo]	Brake Pop [70% intensity]
Quad Flash [Slow]	Tail Mode [10% Intensity]

## DIMENSIONS

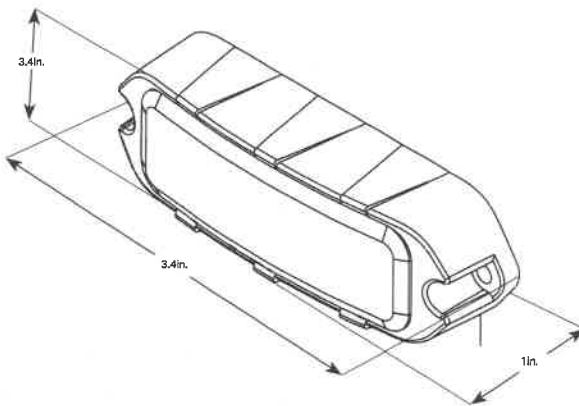

# WIRING DIAGRAM & CONFIGURATION INSTRUCTIONS

## WIRING DIAGRAM

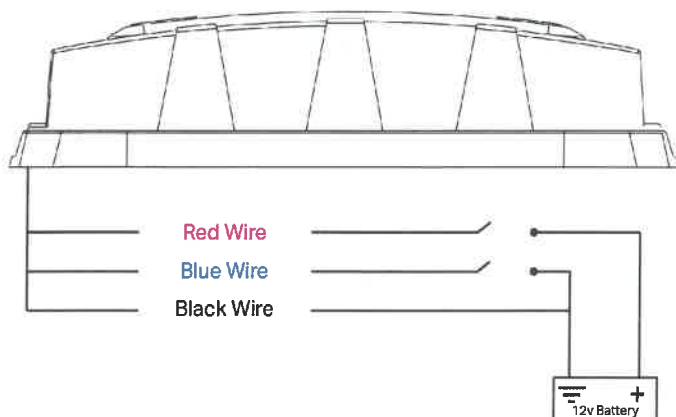

COLOR	FUNCTION	CONNECTION
Red	Battery / 12v (+)	Positive Battery Terminal
Blue	Pattern / 12v (-)	Momentary Switch
Black	Ground / 12v (-)	Chasis Ground

## PATTERNS & SYNCHRONIZATION

- 1) Momentarily tap the blue wire to a ground 12v (-) source to cycle through the flash patterns.
- 2) Synchronization: To synchronize two or more T3 units (or compatible products) together:
  - A) Choose the desired flash pattern for each unit.
  - B) Connect the blue wires of the light heads together.

## POWER

1) To power the unit, extend the red wire to a 12v (+) post. Extend the black wire to the ground post of the vehicle's battery.

**!** To achieve synchronization, the patterns must match on all products connected to the synchronizaton circuit.

## SETTING MASTER/SLAVE

- 1) Apply 12v (+) power and 12v (-) ground to the unit.
- 2) For the light heads to alternate, one light head must be set as master and the other set as slave. To do so, hold the blue (flash pattern changer) wire to ground for 3 seconds. If all LEDs turn on, this indicates master mode. If no LEDs activate, this indicates slave mode.

**!** Each time the master/slave mode is set, the pattern will reset to the default setting (Single Flash [Slow]). This simplifies the process of synchronizing two or more compatible products.

**!** The T3 can be synchronized with other compatible products with matching patterns (single color). Consult the instruction manual of each product as the process may differ by model.

## MOUNTING INSTRUCTIONS

- 1) Place the unit against the selected mounting surface.
- 2) Mark the areas where the mounting holes will be drilled. If the mounting surface is part of the vehicle, make sure no vital components could be damaged by the drilling process.
- 3) Drill two mounting holes in the marked surface as well as a 0.5" diameter hole for wire passage (if mounting on a vehicle). Use the rubber pad to position the 0.5" hole for the wires. Make sure to deburr holes thoroughly. Use a grommet if needed.
- 4) Pass the wires through the 0.5" diameter hole, and secure the light head to the mounting surface with the provided hardware.

