



Department of Administration
 Purchasing Division
 2019 Washington Street East
 Post Office Box 50130
 Charleston, WV 25305-0130

State of West Virginia
 Centralized Request for Quote
 Equipment

Proc Folder: 879525		Reason for Modification:	
Doc Description: Compact Excavator with Attachments			
Proc Type: Central Purchase Order			
Date Issued	Solicitation Closes	Solicitation No	Version
2021-05-10	2021-05-25 13:30	CRFQ 0313 DEP2100000033	1

BID RECEIVING LOCATION

BID CLERK
 DEPARTMENT OF ADMINISTRATION
 PURCHASING DIVISION
 2019 WASHINGTON ST E
 CHARLESTON WV 25305
 US

RECEIVED
 05/24/21 15:32:45
 WV PURCHASING DIVISION

VENDOR

Vendor Customer Code:

Vendor Name : West Virginia Tractor Company

Address : P.O. Box 473

Street : 214 Virginia Street West

City : Charleston

State : WV **Country :** WV **Zip :** 25322

Principal Contact Gary W. Grady

Vendor Contact Phone: 304-346-5301 **Extension:**

FOR INFORMATION CONTACT THE BUYER
 Joseph E Hager III
 (304) 558-2306
 joseph.e.hageriii@wv.gov

Vendor Signature X  **FEIN#** 550621655 **DATE** 5-21-2021

All offers subject to all terms and conditions contained in this solicitation

ADDITIONAL INFORMATION

The West Virginia Purchasing Division is soliciting bids on behalf of West Virginia Department of Environmental Protection (WVDEP), Office of Homeland Security and Emergency Response (HSER), to establish a contract for the one-time purchase of one (1) John Deere 35G or Equal Compact Excavator and the associated listed attachments per the attached specifications and terms and conditions.

INVOICE TO		SHIP TO	
ENVIRONMENTAL PROTECTION HOMELAND SECURITY & EMERGENCY RESPONSE 4994 ELK RIVER RD S ELKVIEW WV US		ENVIRONMENTAL PROTECTION HOMELAND SECURITY & EMERGENCY RESPONSE 4994 ELK RIVER RD S ELKVIEW WV US	

Line	Comm Ln Desc	Qty	Unit Issue	Unit Price	Total Price
1	Compact Excavator with Attachments	1.00000	EA		

Comm Code	Manufacturer	Specification	Model #
30190000	Hyundai	attached	R35Z-9A

Extended Description:

Compact Excavator with Attachments, as listed in attached specifications.

SCHEDULE OF EVENTS

<u>Line</u>	<u>Event</u>	<u>Event Date</u>
-------------	--------------	-------------------

	Document Phase	Document Description	Page
DEP2100000033	Final	Compact Excavator with Attachments	3

ADDITIONAL TERMS AND CONDITIONS

See attached document(s) for additional Terms and Conditions

ADDENDUM ACKNOWLEDGEMENT FORM
SOLICITATION NO.:

Instructions: Please acknowledge receipt of all addenda issued with this solicitation by completing this addendum acknowledgment form. Check the box next to each addendum received and sign below. Failure to acknowledge addenda may result in bid disqualification.

Acknowledgment: I hereby acknowledge receipt of the following addenda and have made the necessary revisions to my proposal, plans and/or specification, etc.

Addendum Numbers Received:

(Check the box next to each addendum received)

- | | |
|--|--|
| <input checked="" type="checkbox"/> Addendum No. 1 | <input type="checkbox"/> Addendum No. 6 |
| <input type="checkbox"/> Addendum No. 2 | <input type="checkbox"/> Addendum No. 7 |
| <input type="checkbox"/> Addendum No. 3 | <input type="checkbox"/> Addendum No. 8 |
| <input type="checkbox"/> Addendum No. 4 | <input type="checkbox"/> Addendum No. 9 |
| <input type="checkbox"/> Addendum No. 5 | <input type="checkbox"/> Addendum No. 10 |

I understand that failure to confirm the receipt of addenda may be cause for rejection of this bid. I further understand that any verbal representation made or assumed to be made during any oral discussion held between Vendor's representatives and any state personnel is not binding. Only the information issued in writing and added to the specifications by an official addendum is binding.

West Virginia Tractor Company

Company

Authorized Signature

5-21-2021

Date

NOTE: This addendum acknowledgment should be submitted with the bid to expedite document processing.

DESIGNATED CONTACT: Vendor appoints the individual identified in this Section as the Contract Administrator and the initial point of contact for matters relating to this Contract.

Gary W. Grady PRES
(Name, Title)
Gary W. Grady President
(Printed Name and Title)
P.O. Box 473 Charleston, WV 25322
(Address)
304-346-5301 304-346-5305
(Phone Number) / (Fax Number)
wvtractor@msn.com
(email address)

CERTIFICATION AND SIGNATURE: By signing below, or submitting documentation through wvOASIS, I certify that: I have reviewed this Solicitation in its entirety; that I understand the requirements, terms and conditions, and other information contained herein; that this bid, offer or proposal constitutes an offer to the State that cannot be unilaterally withdrawn; that the product or service proposed meets the mandatory requirements contained in the Solicitation for that product or service, unless otherwise stated herein; that the Vendor accepts the terms and conditions contained in the Solicitation, unless otherwise stated herein; that I am submitting this bid, offer or proposal for review and consideration; that I am authorized by the vendor to execute and submit this bid, offer, or proposal, or any documents related thereto on vendor's behalf; that I am authorized to bind the vendor in a contractual relationship; and that to the best of my knowledge, the vendor has properly registered with any State agency that may require registration.

By signing below, I further certify that I understand this Contract is subject to the provisions of West Virginia Code § 5A-3-62, which automatically voids certain contract clauses that violate State law.

West Virginia Tractor Company
(Company)

Gary W. Grady PRES
(Authorized Signature) (Representative Name, Title)

Gary W. Grady, President
(Printed Name and Title of Authorized Representative)

5-21-2021
(Date)

304-346-5301 304-346-5305
(Phone Number) (Fax Number)

STATE OF WEST VIRGINIA
Purchasing Division

PURCHASING AFFIDAVIT

CONSTRUCTION CONTRACTS: Under W. Va. Code § 5-22-1(i), the contracting public entity shall not award a construction contract to any bidder that is known to be in default on any monetary obligation owed to the state or a political subdivision of the state, including, but not limited to, obligations related to payroll taxes, property taxes, sales and use taxes, fire service fees, or other fines or fees.

ALL CONTRACTS: Under W. Va. Code §5A-3-10a, no contract or renewal of any contract may be awarded by the state or any of its political subdivisions to any vendor or prospective vendor when the vendor or prospective vendor or a related party to the vendor or prospective vendor is a debtor and: (1) the debt owed is an amount greater than one thousand dollars in the aggregate; or (2) the debtor is in employer default.

EXCEPTION: The prohibition listed above does not apply where a vendor has contested any tax administered pursuant to chapter eleven of the W. Va. Code, workers' compensation premium, permit fee or environmental fee or assessment and the matter has not become final or where the vendor has entered into a payment plan or agreement and the vendor is not in default of any of the provisions of such plan or agreement.

DEFINITIONS:

"Debt" means any assessment, premium, penalty, fine, tax or other amount of money owed to the state or any of its political subdivisions because of a judgment, fine, permit violation, license assessment, defaulted workers' compensation premium, penalty or other assessment presently delinquent or due and required to be paid to the state or any of its political subdivisions, including any interest or additional penalties accrued thereon.

"Employer default" means having an outstanding balance or liability to the old fund or to the uninsured employers' fund or being in policy default, as defined in W. Va. Code § 23-2c-2, failure to maintain mandatory workers' compensation coverage, or failure to fully meet its obligations as a workers' compensation self-insured employer. An employer is not in employer default if it has entered into a repayment agreement with the Insurance Commissioner and remains in compliance with the obligations under the repayment agreement.

"Related party" means a party, whether an individual, corporation, partnership, association, limited liability company or any other form or business association or other entity whatsoever, related to any vendor by blood, marriage, ownership or contract through which the party has a relationship of ownership or other interest with the vendor so that the party will actually or by effect receive or control a portion of the benefit, profit or other consideration from performance of a vendor contract with the party receiving an amount that meets or exceeds five percent of the total contract amount.

AFFIRMATION: By signing this form, the vendor's authorized signer affirms and acknowledges under penalty of law for false swearing (W. Va. Code §61-5-3) that: (1) for construction contracts, the vendor is not in default on any monetary obligation owed to the state or a political subdivision of the state, and (2) for all other contracts, that neither vendor nor any related party owe a debt as defined above and that neither vendor nor any related party are in employer default as defined above, unless the debt or employer default is permitted under the exception above.

WITNESS THE FOLLOWING SIGNATURE:

Vendor's Name: West Virginia Tractor Company

Authorized Signature: *George Inady* Date: 2-21-2021

State of West Virginia

County of Kanwha, to-wit:

Taken, subscribed, and sworn to before me this 21 day of May, 2021.

My Commission expires August 12, 2022.

AFFIX SEAL HERE

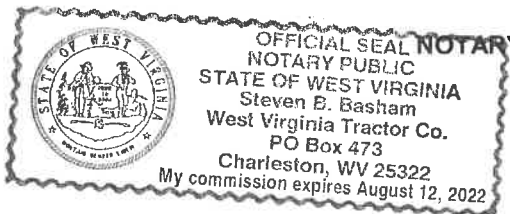

Steven B. Basham

West Virginia Ethics Commission
Disclosure of Interested Parties to Contracts

(Required by *W. Va. Code* § 6D-1-2)

West Virginia Tractor Company

Name of Contracting Business Entity: _____ Address: P.O. Box 473
Charleston, WV 25322

Name of Authorized Agent: Gary W. Grady Address: Charleston, WV

Contract Number: DEP21*33 Contract Description: Compact Excavator

Governmental agency awarding contract: West Virginia Department of Environmental Protection

Check here if this is a Supplemental Disclosure

List the Names of Interested Parties to the contract which are known or reasonably anticipated by the contracting business entity for each category below (*attach additional pages if necessary*):

1. Subcontractors or other entities performing work or service under the Contract

Check here if none, otherwise list entity/individual names below.

2. Any person or entity who owns 25% or more of contracting entity (not applicable to publicly traded entities)

Check here if none, otherwise list entity/individual names below.

Susan Martin
Gary And Christine Grady
Steven Basham

3. Any person or entity that facilitated, or negotiated the terms of, the applicable contract (excluding legal services related to the negotiation or drafting of the applicable contract)

Check here if none, otherwise list entity/individual names below.

Signature: *Gary W. Grady* Date Signed: 5-21-2021

Notary Verification

State of West Virginia, County of Kanawha:

I, Gary W. Grady, the authorized agent of the contracting business entity listed above, being duly sworn, acknowledge that the Disclosure herein is being made under oath and under the penalty of perjury.

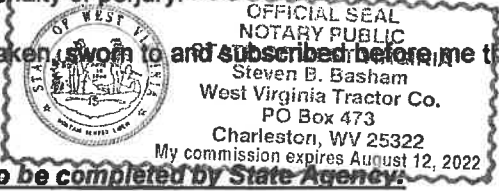
Taken, sworn to and subscribed before me this 21st day of May 2021.

Steven B. Basham
Notary Public's Signature

To be completed by State Agency:
Date Received by State Agency: _____
Date submitted to Ethics Commission: _____
Governmental agency submitting Disclosure: _____

Exhibit A Pricing Page

DEP Compact Excavator and Miscellaneous Equipment

Item	QTY	Unit of Measure	Description	Brand Bid or Equal	Model Bid or Equal	Unit Price	Extended Cost
3.1.1	1	Ea	HYUNDAI R35Z-9A Compact Excavator with Attachments	Hyundai	R35Z-9A	\$42,300	\$42,300 -
3.1.2	1	Ea	24" Digging Bucket	Hyundai	BK50 24"	\$ 450	\$ 450 -
TOTAL BID AMOUNT:							\$ 42,750 -

Company: West Virginia Tractor Company

Address: P.O. Box 473

City: Charleston

State: WV 25322

State of West Virginia

VENDOR PREFERENCE CERTIFICATE

Certification and application is hereby made for Preference in accordance with **West Virginia Code**, §5A-3-37. (Does not apply to construction contracts). **West Virginia Code**, §5A-3-37, provides an opportunity for qualifying vendors to request (at the time of bid) preference for their residency status. Such preference is an evaluation method only and will be applied only to the cost bid in accordance with the **West Virginia Code**. This certificate for application is to be used to request such preference. The Purchasing Division will make the determination of the Vendor Preference, if applicable.

1. Application is made for 2.5% vendor preference for the reason checked:

- Bidder is an individual resident vendor and has resided continuously in West Virginia, or bidder is a partnership, association or corporation resident vendor and has maintained its headquarters or principal place of business continuously in West Virginia, for four (4) years immediately preceding the date of this certification; **or**,
- Bidder is a resident vendor partnership, association, or corporation with at least eighty percent of ownership interest of bidder held by another entity that meets the applicable four year residency requirement; **or**,
- Bidder is a nonresident vendor which has an affiliate or subsidiary which employs a minimum of one hundred state residents and which has maintained its headquarters or principal place of business within West Virginia continuously for the four (4) years immediately preceding the date of this certification; **or**,

2. Application is made for 2.5% vendor preference for the reason checked:

- Bidder is a resident vendor who certifies that, during the life of the contract, on average at least 75% of the employees working on the project being bid are residents of West Virginia who have resided in the state continuously for the two years immediately preceding submission of this bid; **or**,

3. Application is made for 2.5% vendor preference for the reason checked:

- Bidder is a nonresident vendor that employs a minimum of one hundred state residents, or a nonresident vendor which has an affiliate or subsidiary which maintains its headquarters or principal place of business within West Virginia and employs a minimum of one hundred state residents, and for purposes of producing or distributing the commodities or completing the project which is the subject of the bidder's bid and continuously over the entire term of the project, on average at least seventy-five percent of the bidder's employees or the bidder's affiliate's or subsidiary's employees are residents of West Virginia who have resided in the state continuously for the two immediately preceding years and the vendor's bid; **or**,

4. Application is made for 5% vendor preference for the reason checked:

- Bidder meets either the requirement of both subdivisions (1) and (2) or subdivision (1) and (3) as stated above; **or**,

5. Application is made for 3.5% vendor preference who is a veteran for the reason checked:

- Bidder is an individual resident vendor who is a veteran of the United States armed forces, the reserves or the National Guard and has resided in West Virginia continuously for the four years immediately preceding the date on which the bid is submitted; **or**,

6. Application is made for 3.5% vendor preference who is a veteran for the reason checked:

- Bidder is a resident vendor who is a veteran of the United States armed forces, the reserves or the National Guard, if, for purposes of producing or distributing the commodities or completing the project which is the subject of the vendor's bid and continuously over the entire term of the project, on average at least seventy-five percent of the vendor's employees are residents of West Virginia who have resided in the state continuously for the two immediately preceding years.

7. Application is made for preference as a non-resident small, women- and minority-owned business, in accordance with West Virginia Code §5A-3-59 and West Virginia Code of State Rules.

- Bidder has been or expects to be approved prior to contract award by the Purchasing Division as a certified small, women- and minority-owned business.

8. Application is made for reciprocal preference.

- Bidder is a West Virginia resident and is requesting reciprocal preference to the extent that it applies.

Bidder understands if the Secretary of Revenue determines that a Bidder receiving preference has failed to continue to meet the requirements for such preference, the Secretary may order the Director of Purchasing to: (a) rescind the contract or purchase order; or (b) assess a penalty against such Bidder in an amount not to exceed 5% of the bid amount and that such penalty will be paid to the contracting agency or deducted from any unpaid balance on the contract or purchase order.

By submission of this certificate, Bidder agrees to disclose any reasonably requested information to the Purchasing Division and authorizes the Department of Revenue to disclose to the Director of Purchasing appropriate information verifying that Bidder has paid the required business taxes, provided that such information does not contain the amounts of taxes paid nor any other information deemed by the Tax Commissioner to be confidential.

Bidder hereby certifies that this certificate is true and accurate in all respects; and that if a contract is issued to Bidder and if anything contained within this certificate changes during the term of the contract, Bidder will notify the Purchasing Division in writing immediately.

Bidder: West Virginia Tractor Company

Signed: 

Date: 5-17-21

Title: President

*Check any combination of preference consideration(s) indicated above, which you are entitled to receive.

Dimensions & Working Range

R35Z-9A DIMENSIONS

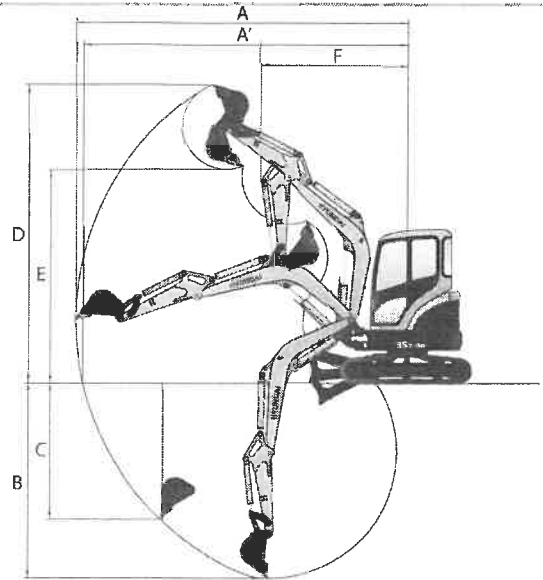
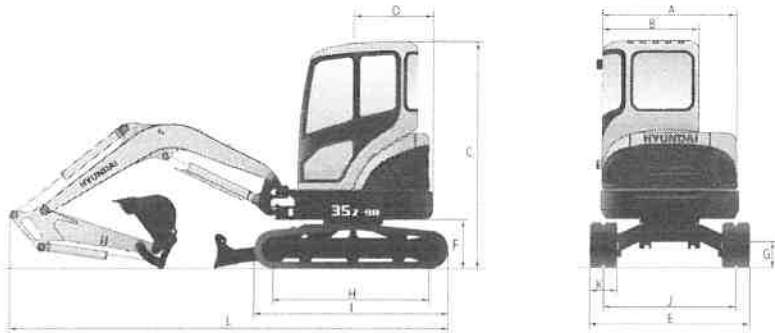

R35Z-9A DIMENSIONS

		mm (ft-in)			
A	Overall width of upper structure	1,500 (4' 11")	G Ground clearance	290 (0' 11")	
B	Overall width of cab	1,050 (3' 5")	H Tumbler distance	1,700 (5' 7")	
C	Overall height of cab	2,500 (8' 2")	I Track length	2,130 (7' 10")	
D	Tail swing radius	870 (2' 10")	J Track gauge	1,440 (4' 9")	
E	Overall width	1,740 (5' 9")	K Track shoe width	300 (1' 0")	
F	Clearance under counterweight	540 (1' 9")	L Overall length	1,300-mm Arm	4,790 (15' 9")
				1,600-mm Arm	4,815 (15' 10")

R35Z-9A WORKING RANGE

		mm (ft-in)	
Boom length		2,500 (8' 2")	
Arm length		1,300 (4' 3")	1,600 (5' 3")
A	Max. digging reach	5,315 (17' 5")	5,605 (18' 5")
A'	Max. digging reach on ground	5,200 (17' 1")	5,495 (18' 0")
B	Max. digging depth	3,135 (10' 3")	3,440 (11' 3")
C	Max. vertical wall digging depth	2,190 (7' 2")	2,565 (8' 5")
D	Max. digging height	4,810 (15' 9")	5,010 (16' 5")
E	Max. dumping height	3,425 (11' 3")	3,615 (11' 10")
F	Min. swing radius	2,350 (7' 9")	2,330 (7' 8")

STANDARD EQUIPMENT

- Cabin** TOPS ISO 12117 (ROPS ISO 12117-2) FOG ISO 10262 Level I (FOPS ISO 3449 Level I)
- All-weather steel cab with all-around visibility
 Safety glass windows
 Sliding fold-in front window
 Sliding side window
 Lockable door
 Accessory box
 Air conditioner and heater
 Centralized monitoring
Gauges
- Fuel level gauge
 - Engine coolant temperature gauge

- Warning indicators**
- Quick clamp
 - Engine oil pressure
 - Engine coolant temperature
 - Preheat
 - Low battery
 - Air cleaner clogging
 - Fuel empty
- Door and locks, universal key
 Mechanical suspension seat with seat belt
 Radio / USB Player
 Console box tilting system (LH)
 One front working lights
 Electric horn
 Battery (1 x 12 V x 70 AH)
 Battery master switch
 Automatic swing brake

- Removable reservoir tank
 Water separator, fuel line
 Mono boom (2.5 m / 8' 2")
 Arm (1.3 m / 4' 3")
 Rubber track shoes (300 mm / 12")
 Double acting piping (Clamshell, etc)
 Auto idle function
 Universal start key
 Emergency stop switch
 Auto travel shift down travel motor
 Cabin lamp
 Travel alarm
 Quick coupler with piping
 Heater and defroster
 Pattern-change lever
 Hyundai bucket (0.11 m³ / 0.14 yd³)

OPTIONAL EQUIPMENT

- Canopy** TOPS ISO 12117 (ROPS ISO 12117-2) FOG ISO 10262 Level I (FOPS ISO 3449 Level I)

- Accumulator
 Steel track shoes (300 mm / 12")
 Long Arm (1.6 m)
 Additional counterweight (150 kg / 330 lb)

- RCV with proportional control switch
 Rotating attachment piping
 Safety lock valve



www.hceamericas.com

6100 Atlantic Blvd., Norcross, GA 30071

TEL (678) 823 7777 FAX (678) 823 7778

Hyundai R35z-9A

Specifications

Net Power 23.7 hp
(17.7 kW) at 2,200 rpm
Bucket Breakout Force
(ISO) 3,130 kgf / 6,900 lbf

Operating Weight (cab / canopy)
3,840 kg (8,470 lb) / 3,550 kg (7,800 lb)
Arm Digging Force
(ISO) 1,990 kgf / 4,390 lbf

ENGINE

MODEL	YANMAR 3TNV88F	
Type	Water-cooled, 4-cycle diesel 3 cylinders in line, direct injection, low emission	
Rated flywheel horsepower	SAE J1995 (gross)	24.4 HP (18.2 kW) at 2,200 rpm
	J1349 (net)	23.7 HP (17.7 kW) at 2,200 rpm
Max. torque	9.1 kgf·m (79 lbf·ft) at 1,320 rpm	
Bore X stroke	88 mm (3.46") x 90 mm (3.54")	
Piston displacement	1,642 cc (100 in ³)	
Battery	1 x 12V x 70 Ah	
Starting motor	12 V - 2.3 kW	
Alternator	12 V - 55 Amp	

HYDRAULIC SYSTEM

MAIN PUMP	
Type	Variable displacement piston pumps + gear pump
Max. flow	2 x 37.4 ℓ/min (2 x 9.9 gpm) + 23.1 ℓ/min (6.1 gpm) at 2,200 rpm
Sub-pump for pilot circuit (Gear Pump)	23.1 / 9.9 ℓ/min (6.1 / 2.6 gpm)

CROSS-SENSING AND FUEL-SAVING PUMP SYSTEM

HYDRAULIC MOTORS	
Travel	Two-speed axial piston motor with counter balance valve and parking brake
Swing	Axial piston motor with automatic brake

RELIEF VALVE SETTING

Implement circuits	230 kgf/cm ² (3,560 psi)
Travel circuit	230 kgf/cm ² (3,270 psi)
Swing circuit	200 kgf/cm ² (2,845 psi)
Pilot circuit	40 kgf/cm ² (570 psi)
Service valve	Installed

HYDRAULIC CYLINDERS

No. of cylinders bore X stroke	Boom: 85 x 540 mm (3.3" x 21.3")
	Arm: 80 x 585 mm (3.1" x 23.0")
	Bucket: 70 X 510 mm (2.8" x 20.1")
	Boom swing: 80 X 400 mm (3.1" x 15.7")
	Dozer blade: 95 X 152 mm (3.7" x 6.0")

TRAVEL SYSTEM

Drive method	Full hydrostatic type
Drive motor	Axial piston motor, in-shoe design
Reduction system	2-stage planetary
Max. drawbar pull	3,100 kgf (6,835 lbf)
Max. travel speed (high) / (low)	4.2 km/hr (2.6 mph) / 2.5 km/hr (1.6 mph)
Gradeability	30° (58%)
Parking brake	Multi-wet disc

CONTROLS

Pilot-pressure-operated joysticks and pedals with detachable lever provide almost effortless and fatigueless operation.

Pilot control	Two joysticks with one safety lever (LH): Arm swing, Boom swing (RH): Boom and bucket with horn (ISO)
Traveling and steering	Two levers with pedals
Engine throttle	Electric, dial type

SWING SYSTEM

Swing motor	Axial piston motor
Swing reduction	2-stage planetary
Swing bearing lubrication	Grease-bathed
Swing brake	Multi wet disc
Swing speed	9.5 rpm

COOLANT AND LUBRICANT CAPACITY

(Refilling)	liter	gal
Fuel tank	40.0	10.5
Engine coolant	5.5	1.5
Engine oil	6.7	1.8
Hydraulic tank	37.0	9.8
Hydraulic system	60	15.9

WEIGHT (APPROXIMATE)

Operating weight, including 2,500 mm (8' 12") boom, 1,300 mm (4' 3") arm, SAE heaped 0.11 m³ (0.14 yd³) excavator bucket, 300 mm (11.8") rubber track, lubricant, coolant, full fuel tank, hydraulic tank, 560 kg (1,230 lb) counterweight and the standard equipment.

Operating weight (canopy)	3,550 kg (7,800 lb)
Ground pressure (canopy)	0.33 kg/cm ² (4.69 psi)

UNDERCARRIAGE







X-leg type center frame is integrally welded with reinforced box-section track frames. The undercarriage includes lubricate rollers, track adjusters with shock absorbing springs and sprockets, and track chain with triple grouser shoes.

Center frame	X - leg type
Track frame	Pentagonal box type
No. of track shoes on each side	44
No. of upper rollers on each side	1
No. of lower rollers on each side	4

R35Z-9A Lifting Capacity ISO Condition 2

 Rating over front  Rating over side or 360 degree

Boom: 2.50 m (8' 2") / Arm: 1.30 m (4' 3") / Bucket: 0.11 m³ (0.14 yd³) SAE heaped / Dozer down / Rubber track: 300 mm (12") / Cabin Type / Counterweight: 560 kg (1,230 lb)

Lift-point height m (ft)		Lift-point radius						At max. reach	
		1.0 m (3.3 ft)		2.0 m (6.6 ft)		3.0 m (9.8 ft)		4.0 m (13.1 ft)	
								Capacity	Reach
									m(ft)
4.0 m	kg							*670	3.12
13.1 ft	lb							*1,470	(10.2)
3.0 m	kg						*620	*630	4.04
9.8 ft	lb						590	580	(13.3)
2.0 m	kg			*790	*790	*1,370	1,300	*1,380	1,280
6.6 ft	lb			*1,730	*1,730	*1,430	1,280	*1,390	1,070
1.0 m	kg			*1,060	850	*740	560	*650	450
3.3 ft	lb			*2,340	1,870	*1,620	1,230	*1,430	1,000
0.0 m	kg			*1,260	*1,260	*1,190	810	*670	470
0.0 ft	lb			*2,770	*2,770	*2,620	1,800	*1,480	1,030
-1.0 m	kg	*1,930	*1,930	*1,890	1,550	*1,110	810	*690	550
-3.3 ft	lb	*4,250	*4,250	*4,160	3,430	*2,440	1,790	*1,520	1,210
-2.0 m	kg			*1,210	*1,210	*670	*670	*650	3.03
-6.6 ft	lb			*2,670	*2,670	*1,490	*1,490	*1,440	(9.9)

Notes:
1. Lifting capacities are based on ISO 10567.
2. Lifting capacities of the 9A Series does not exceed 75% of tipping load with the machine on firm, level ground or 87% of full hydraulic capacity.

3. The lift-point is a hook (standard equipment) located on the back of the bucket.
4. (*) indicates load limited by hydraulic capacity.