



The following documentation is an electronically-submitted vendor response to an advertised solicitation from the *West Virginia Purchasing Bulletin* within the Vendor Self-Service portal at *wvOASIS.gov*. As part of the State of West Virginia's procurement process, and to maintain the transparency of the bid-opening process, this documentation submitted online is publicly posted by the West Virginia Purchasing Division at *WVPurchasing.gov* with any other vendor responses to this solicitation submitted to the Purchasing Division in hard copy format.

Header 3

[List View](#)

General Information | Contact | Default Values | Discount | Document Information | Clarification Request

Procurement Folder: 826615

Procurement Type: Central Purchase Order

Vendor ID: VS0000037280 

Legal Name: All Around Access LLC

Alias/DBA:

Total Bid: \$126,995.00

Response Date: 02/03/2021 

Response Time: 10:32

Responded By User ID: allaroundaccess 

First Name: Rick

Last Name: Mellert

SO Doc Code: CRFQ

SO Dept: 0211

SO Doc ID: GSD2100000026

Published Date: 1/22/21

Close Date: 2/4/21

Close Time: 13:30

Status: Closed

Solicitation Description: JLG 860SJ (or equal) Telescopic Boom Lift

Total of Header Attachments: 3

Total of All Attachments: 3



Department of Administration
 Purchasing Division
 2019 Washington Street East
 Post Office Box 50130
 Charleston, WV 25305-0130

**State of West Virginia
 Solicitation Response**

Proc Folder: 826615
Solicitation Description: JLG 860SJ (or equal) Telescopic Boom Lift
Proc Type: Central Purchase Order

Solicitation Closes	Solicitation Response	Version
2021-02-04 13:30	SR 0211 ESR02032100000005200	1

VENDOR
 VS0000037280
 All Around Access LLC

Solicitation Number: CRFQ 0211 GSD2100000026
Total Bid: 126995
Response Date: 2021-02-03
Response Time: 10:32:05
Comments:

FOR INFORMATION CONTACT THE BUYER
 Melissa Pettrey
 (304) 558-0094
 melissa.k.pettrey@wv.gov

Vendor Signature X **FEIN#** **DATE**

All offers subject to all terms and conditions contained in this solicitation

Line	Comm Ln Desc	Qty	Unit Issue	Unit Price	Ln Total Or Contract Amount
1	JLG 860SJ (or equal) Telescopic Boom Lift	1.00000	EA	126995.000000	126995.00

Comm Code	Manufacturer	Specification	Model #
20102306			

Commodity Line Comments: New Skyjack SJ86T Boom Lift. 86' Platform Height, Diesel Engine. Please see attached general requirements to see how Skyjack 86T meets specification. Local warranty service will be provided. Current lead time is mid-late March. Lead time subject to change due to COVID-19. On-site training will be provided.

Extended Description:

JLG 860SJ (or equal) Telescopic Boom Lift



Department of Administration
 Purchasing Division
 2019 Washington Street East
 Post Office Box 50130
 Charleston, WV 25305-0130

State of West Virginia
 Centralized Request for Quote
 Equipment

Proc Folder: 826615			Reason for Modification:
Doc Description: JLG 860SJ (or equal) Telescopic Boom Lift			
Proc Type: Central Purchase Order			
Date Issued	Solicitation Closes	Solicitation No	Version
2021-01-22	2021-02-04 13:30	CRFQ 0211 GSD2100000026	1

BID RECEIVING LOCATION

BID CLERK
 DEPARTMENT OF ADMINISTRATION
 PURCHASING DIVISION
 2019 WASHINGTON ST E
 CHARLESTON WV 25305
 US

VENDOR

Vendor Customer Code:
 Vendor Name: ALL AROUND ACCESS LLC
 Address: 2095 47th AVE NE
 Street:
 City: NAPLES
 State: FL Country: USA Zip: 34120
 Principal Contact: RICK MELLERT
 Vendor Contact Phone: 239-206-7594 Extension:

FOR INFORMATION CONTACT THE BUYER
 Melissa Pettrey
 (304) 558-0094
 melissa.k.pettrey@wv.gov

Vendor Signature X *Rick Mellert* FEIN# 27-3987945 DATE 2/2/2021

All offers subject to all terms and conditions contained in this solicitation

All Around Access

ADDITIONAL INFORMATION

Request for Quotation

The West Virginia Purchasing Division is soliciting bids on behalf of West Virginia Department of Administration to establish a contract for the one time purchase of one (1) JLG 860SJ (or equal) Telescopic Boom Lift for the General Services Division located at 1900 Kanawha Boulevard East, Charleston, WV 25305. per the specifications and terms and conditions as attached hereto.

Machine must be delivered, assembled and set-up on site, vendor must provide training to the agency on operation and maintenance of the unit.

INVOICE TO	SHIP TO
DEPARTMENT OF ADMINISTRATION GENERAL SERVICES DIVISION 112 CALIFORNIA AVENUE, 5TH FLOOR CHARLESTON WV 25305 US	DEPARTMENT OF ADMINISTRATION GENERAL SERVICES DIVISION GROUNDS SECTION - LOT/ BLDG 98 321 MICHIGAN AVE CHARLESTON WV 25305 US

Line	Comm Ln Desc	Qty	Unit Issue	Unit Price	Total Price
1	JLG 860SJ (or equal) Telescopic Boom Lift	1.00000	EA	\$126,995	\$126,995

Comm Code	Manufacturer	Specification	Model #
20102306	SKYJACK	SJ86T	86T

Extended Description:
JLG 860SJ (or equal) Telescopic Boom Lift

SCHEDULE OF EVENTS

Line	Event	Event Date
------	-------	------------

DESIGNATED CONTACT: Vendor appoints the individual identified in this Section as the Contract Administrator and the initial point of contact for matters relating to this Contract.

RICK MELLERT MANAGER

(Name, Title)

(Printed Name and Title)

2095 47th AVE NE NAPLES FL 34120

(Address)

239-206-7594 F: 855-834-7319

(Phone Number) / (Fax Number)

rick@allaroundaccess.com

(email address)

CERTIFICATION AND SIGNATURE: By signing below, or submitting documentation through wvOASIS, I certify that I have reviewed this Solicitation in its entirety; that I understand the requirements, terms and conditions, and other information contained herein; that this bid, offer or proposal constitutes an offer to the State that cannot be unilaterally withdrawn; that the product or service proposed meets the mandatory requirements contained in the Solicitation for that product or service, unless otherwise stated herein; that the Vendor accepts the terms and conditions contained in the Solicitation, unless otherwise stated herein; that I am submitting this bid, offer or proposal for review and consideration; that I am authorized by the vendor to execute and submit this bid, offer, or proposal, or any documents related thereto on vendor's behalf; that I am authorized to bind the vendor in a contractual relationship; and that to the best of my knowledge, the vendor has properly registered with any State agency that may require registration.

ALL AROUND ACCESS LLC

(Company)

Rick Mellert MANAGER

(Authorized Signature) (Representative Name, Title)

RICK MELLERT MANAGER

(Printed Name and Title of Authorized Representative)

2/3/2021

(Date)

239-206-7594 F: 855-834-7319

(Phone Number) (Fax Number)

ADDENDUM ACKNOWLEDGEMENT FORM

SOLICITATION NO.: CRFQ GSD2100000026

Instructions: Please acknowledge receipt of all addenda issued with this solicitation by completing this addendum acknowledgment form. Check the box next to each addendum received and sign below. Failure to acknowledge addenda may result in bid disqualification.

Acknowledgment: I hereby acknowledge receipt of the following addenda and have made the necessary revisions to my proposal, plans and/or specification, etc.

Addendum Numbers Received:

(Check the box next to each addendum received)

- | | |
|---|--|
| <input type="checkbox"/> Addendum No. 1 | <input type="checkbox"/> Addendum No. 6 |
| <input type="checkbox"/> Addendum No. 2 | <input type="checkbox"/> Addendum No. 7 |
| <input type="checkbox"/> Addendum No. 3 | <input type="checkbox"/> Addendum No. 8 |
| <input type="checkbox"/> Addendum No. 4 | <input type="checkbox"/> Addendum No. 9 |
| <input type="checkbox"/> Addendum No. 5 | <input type="checkbox"/> Addendum No. 10 |

I understand that failure to confirm the receipt of addenda may be cause for rejection of this bid. I further understand that any verbal representation made or assumed to be made during any oral discussion held between Vendor's representatives and any state personnel is not binding. Only the information issued in writing and added to the specifications by an official addendum is binding.

ALL AROUND ACCESS LLC
Company

Rich Muller
Authorized Signature

2/3/2021
Date

NOTE: This addendum acknowledgment should be submitted with the bid to expedite document processing.

All Around Access

REQUEST FOR QUOTATION
JLG 860SJ or equal Telescopic Mounted Boom Lift

SPECIFICATIONS

1. **PURPOSE AND SCOPE:** The West Virginia Purchasing Division is soliciting bids on behalf of West Virginia Department of Administration to establish a contract for the one time purchase of one (1) JLG 860SJ (or equal) Telescopic Boom Lift for the General Services Division located at 1900 Kanawha Boulevard East, Charleston, WV 25305. Machine must be delivered, assembled and set-up on site, vendor must provide training to the agency on operation and maintenance of the unit.

2. **DEFINITIONS:** The terms listed below shall have the meanings assigned to them below. Additional definitions can be found in Section 2 of the General Terms and Conditions.

2.1 "Contract Item" means JLG 860SJ (or equal) Telescopic Boom Lift as more fully described by these specifications.

2.2 "Pricing Page" means the pages, contained in wVOASIS, or attached as Exhibit A, upon which Vendor should list its proposed price for the Contract Items.

2.3 "Solicitation" means the official notice of an opportunity to supply the State with goods or services that is published by the Purchasing Division.

3. **GENERAL REQUIREMENTS:**

3.1 **Mandatory Contract Item Requirements:** Contract Item must meet or exceed the mandatory requirements listed below.

3.1.1 Contract Item #1 — JLG 860SJ (or equal) Telescopic Boom Lift

3.1.1.1 Must have a maximum platform height of at least 86 feet.

3.1.1.2 Must have a maximum restricted platform capacity of at least 750 pounds.

3.1.1.3 Must have a maximum unrestricted platform capacity of at least 500 pounds.

3.1.1.4 Must have a horizontal outreach of at least 75 feet.

3.1.1.5 Must have a horizontal reach minimum of 30 feet.

3.1.1.6 Must be all wheel drive.

SKYJACK 86T
→ 86'
86' platform height

↳ ALL WHEEL DRIVE / FOUR WHEEL DRIVE

All Around Accept

REQUEST FOR QUOTATION
JLG 860SJ or equal Telescopic Mounted Boom Lift

- 3.1.1.7 Must have an engine at least equal in performance to a Deutz TD 2.9L, Tier 4, 67 HP *74 HP DEUTZ DIESEL TD 2.9 L ENGINE*
- 3.1.1.8 Must have a diesel engine - *DIESEL ENGINE*
- 3.1.1.9 Must have a 360-degree continuous swing. *360° Continuous swing*
- 3.1.1.10 Must have 15" filled lug tread tires *18" Bam filled Grip Lug TIRES*
- 3.1.1.11 Shall include covers for all controls if available. *plst control cover*
- 3.1.1.12 Shall include a cover for the bucket if available. - *Not available*
- 3.1.1.13 Must be delivered and assembled on site at the agency location, Vendor must include all shipping and delivery charges up-front in their total bid amount.
- 3.1.1.14 Must include a minimum 1-year product warranty or equal. - *2 year parts labor*

4. CONTRACT AWARD:

- 4.1 The Contract is intended to provide Agencies with a purchase price for the Contract Items. The Contract shall be awarded to the Vendor that provides the Contract Items meeting the required specifications for the lowest overall total cost as shown on the Pricing Pages.

Pricing Page: Vendor should complete the Pricing Page by completing Commodity Line 1 on the wvOASIS page. Vendor should complete the Pricing Page in full as failure to complete the Pricing Page in its entirety may result in Vendor's bid being disqualified.

TOTAL BID AMOUNT is the amount Vendor is to enter into wvOASIS commodity line when submitting. Notwithstanding the foregoing, the Purchasing Division may correct errors at its discretion.

- 4.2 Vendor should type or electronically enter the information into the Pricing Page to prevent errors in the evaluation.

SJ82/86 T

TELESCOPIC BOOMS



STANDARD FEATURES

- EASYDRIVE™ Direction sensing drive and steer controls
- AXLDRIIVE™ Axle-based 4WD system
- Operator controlled locking rear differential and limited slip front differential
- Oscillating steer axle
- Drivable at full height
- 45% Gradeability
- Wet disc SAHR brakes (front and rear axle)
- Relay based control system with SKYCODED™ color coded and numbered wiring
- Deutz TD2.9L4 diesel engine
- Swing out engine tray
- Swing up cowlings for easy access
- Lockable power disconnect switch
- Proportional controls
- 500/750 lbs (227/341 kg) Dual capacity
- 36" x 96" Platform
- Bolt-in platform railing system
- Lanyard attachment points
- Tri-entry sliding mid rails
- Secondary Guarding Electrical (SGE)
- Overload sensing system
- 110V AC Outlet on platform with GFI
- Tilt alarm (5.0° x 5.0°) with drive and lift cut-out
- Single point emergency lowering
- Hourmeter
- Operator horn
- All motion alarm
- 360° Continuous turret rotation
- Tie down/lifting lugs
- 18 x 625 Grip lug foam-filled tires
- Telematics ready
- 2-Year Gold Leaf Warranty (5-year structural warranty)

OPTIONS

- Glazier kit
- Pipe rack
- Tool caddy
- Flashing light
- 36" x 72" Platform
- Side spring hinged entry gate
- Auxiliary top rail (36" x 96" platform only)
- 3.5 kW Generator (Includes hydraulic oil cooler)
- Welder ready package (Includes 12 kW generator, hydraulic oil cooler, 3-phase power connection in platform, and welder mount)
- Welder package (Includes 12 kW generator, hydraulic oil cooler, 3-phase power connection in platform, welder mount, and Lincoln V275-S welder)
- Cold weather start kit (Recommended for regions where average monthly low temperatures can reach 14°F / -10°C (Includes cold start engine oil, battery blanket, hydraulic tank heater, and engine load kit (Deutz TD2.9L4))
- Arctic weather package (Recommended for regions where average monthly low temperatures can reach -0.4°F / -18°C (Includes arctic engine oil, battery blanket, hydraulic tank heater, engine load kit (Deutz TD2.9L4), block heater, arctic hydraulic oil, arctic platform rotator and arctic gear oil in the axles and swing drive glow plugs, arctic hydraulic hoses (all), and oversized foot switch cover are also included (standard equipment).)
- Positive air shut-off valve (diesel only)
- Hydraulic oil cooler
- Bio oil
- Hostile environment package (Includes cylinder bellows, boom wipers, covers for the fly boom cutouts, and control box cover)
- Control box cover
- Lifting Lugs
- 18 x 625 Grip lug foam-filled non-marking tires
- Non-destructive testing
- ELEVATE telematics

† Standard lead times may be increased when optional equipment is added, consult factory.
‡ Capacities and machine weights may differ when options are added.

SJ82/86 T TELESCOPIC BOOMS

Dimensions	SJ82 T	SJ86 T
Work Height	88' (26.82 m)	92' (28.04 m)
Platform Height	82' (24.99 m)	86' (26.21 m)
Horizontal Reach	72' 6" (22.10 m)	76' 10" (23.42 m)
A Platform Size	36" x 96" (0.91 x 2.44 m)	36" x 96" (0.91 x 2.44 m)
B Stowed Width	8' 2" (2.49 m)	8' 2" (2.49 m)
C Tailswing	4' 8" (1.42 m)	4' 8" (1.42 m)
D Stowed Height	9' 10" (3.00 m)	9' 10" (3.00 m)
E Transportation Height	-	10' 3" (3.13 m)
F Stowed Length	37' 10" (11.53 m)	42' 6" (12.95 m)
G Transportation Length	-	34' 9" (10.59 m)
H Wheelbase	11' (3.35 m)	11' (3.35 m)
I Ground Clearance	16" (0.41 m)	16" (0.41 m)
Specifications	SJ82 T	SJ86 T
Rotation	360° Continuous	
Platform Rotation	170°	170°
Jib Length	-	5' 6" (1.68 m)
Jib Range +/-	-	+65° / -60°
Weight	37,600 lbs (17,055 kg)	38,691 lbs (17,550 kg)
Gradeability	45%	45%
Turning Radius (Inside)	11' 6" (3.51 m)	11' 6" (3.51 m)
Turning Radius (Outside)	21' (6.40 m)	21' (6.40 m)
Axle Oscillation	4" (10.16 cm)	4" (10.16 cm)
Drive Speed (High speed)	3 mph (4.8 km/h)	3 mph (4.8 km/h)
Capacity	500 / 750 lbs (227 / 340 kg)	500 / 750 lbs (227 / 340 kg)
Maximum wind rating	28 mph (12.5 m/s)	28 mph (12.5 m/s)
Personnel Rating at Max Wind Rating	2 / 3	2 / 3
Tire Type	Foam-Filled	Foam-Filled
Tire Size	18-625	18-625
Diesel Engine	Deutz TD2.9L - 74 HP (55 KW)	
Fuel Tank Capacity	45 gal. (170 L)	
Hydraulic Reservoir	60 gal. (227 L)	

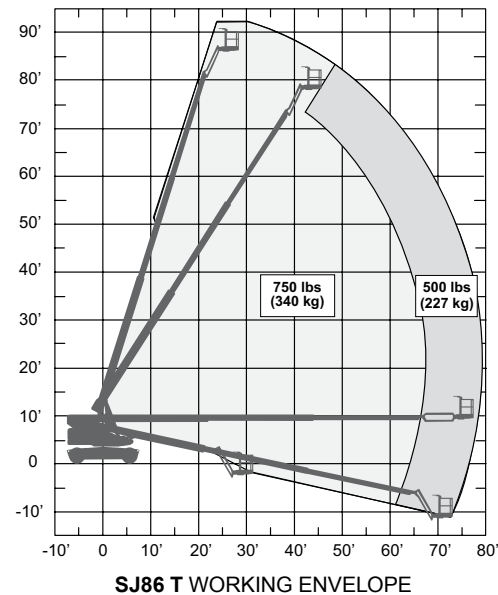
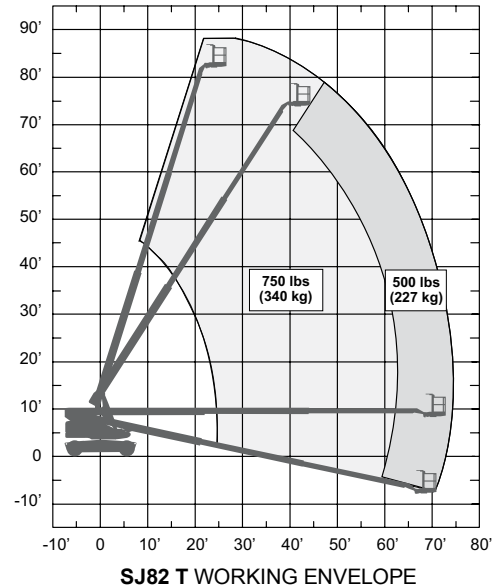
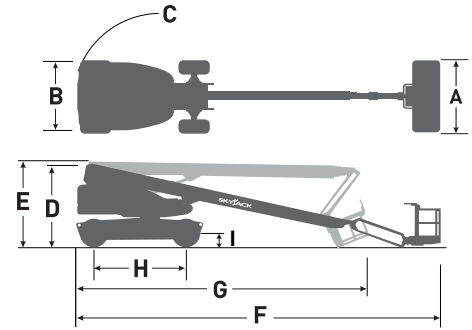

Skyjack Head Office
 55 Campbell Rd. Guelph, ON Canada N1H 1B9
 Sales Inquiries: 1-877-755-4387 (1-877-SJLIFTS)
 Main Switchboard: 1-800-265-2738
 Phone: 519-837-0888
 Fax: 519-837-8104
 Email: skyjack@skyjack.com

www.skyjack.com

SKYJACK
 simply reliable

WARRANTY – NEW SKYJACK LIFTS AND TELEHANDLERS

2 YEAR GOLD LEAF PROTECTION: SCISSOR LIFTS AND BOOM LIFTS

Subject to the terms and conditions hereof, SKYJACK INC. (“Skyjack”) warrants to the original buyer (“Buyer”) that each new aerial work platform (“AWP”) will be free of defective parts and workmanship under normal use and service for two years (24 months) from the date the product was invoiced to the Buyer or from the date the product was first put into service, whichever comes first. For the following 36 months, structural components found to be defective will be replaced or repaired at no charge. For further clarity, AWP Products include only Vertical Mast Lifts, Scissor Lifts and Boom Lifts.

2 YEAR GOLD LEAF PROTECTION: TELEHANDLERS

Subject to the terms and conditions hereof, SKYJACK INC., warrants to the Buyer that each new Telehandler manufactured by Skyjack Inc. will be free of defective parts and workmanship under normal use and service for (a) 3,000 hours of use; (b) two years (24 months) from the date the Telehandler was invoiced to the Buyer or (c) two years (24 months) from the date the Telehandler was first put into service, whichever comes first. For the following three years (36 months), structural components found to be defective will be replaced or repaired at no charge.

Warranty Terms and Policies:

No claims under this warranty shall be valid unless written notice of the defect is provided to Skyjack or its authorized distributor within thirty (30) days after such defect is first discovered, and no longer than thirty (30) days after the end of the applicable warranty period. The failure to follow Skyjack’s warranty claim procedures as described herein (and as may be modified by Skyjack from time-to-time) will invalidate the applicable warranty.

Skyjack’s sole obligation to the Buyer is limited to the repair or replacement of any products or parts which Skyjack, in its sole discretion, determines to be defective in materials or workmanship, at Skyjack’s option. Replacement products or parts may be new or factory approved reconditioned parts, at Skyjack’s sole discretion. All repairs or replacement must be performed by technicians trained and qualified in accordance with ANSI standards, using only genuine Skyjack supplied parts, and must be made in accordance with the Warranty Claim Procedures provided herein. Any parts repaired or replaced under the warranty are warranted only for the balance of the warranty period on the part that was repaired or replaced.

Skyjack does not provide any warranty, and specifically disclaims any liability, relating to defective component parts or accessories that are not manufactured by Skyjack (for example, batteries, tires, engines, drive train components); however, Buyer may be entitled to the respective part’s Original Equipment Manufacturer (OEM) pass-through warranty, if any (subject to any OEM terms and conditions).

This warranty does not apply to ordinary wear and tear. This warranty also does not apply to negligence; use beyond the products’ rated capacity or other misuse or neglect; improper installation, storage or operation; lack of normal maintenance and/or inspections as outlined in Skyjack’s Operator’s Manual or Parts, Operation and Maintenance Manual, or any Skyjack technical bulletins (“Manuals”); service or repairs other than by

technicians trained and qualified in accordance with ANSI standards, or using parts other than genuine Skyjack supplied parts (unless authorized in writing by Skyjack); electrical failures due to loose wiring or corrosion; alterations to original designs and/or components; accidents, floods, fires or other natural disasters or acts of God; the introduction of foreign materials to the products; or duties, taxes, environmental fees, including without limitations, disposal or handling of tires, batteries, and petrochemical items.

Skyjack's liability with respect to the products sold to Buyer shall be limited to this warranty, which constitutes Skyjack's entire and exclusive warranty as to the products and is the sole and exclusive remedy for defects in material and workmanship. Skyjack does not assume (and has not authorized any other person to assume on its behalf) any other warranty or liability in connection with any products covered by this warranty. In no event shall Skyjack's liability exceed the cost to repair or replace a defective product or part.

SKYJACK SHALL NOT BE SUBJECT TO ANY OTHER OBLIGATIONS OR LIABILITIES INCLUDING WITHOUT LIMITATION, CLAIMS FOR PERSONAL INJURY, DEATH, DISMEMBERMENT AND/OR PROPERTY DAMAGE (WHETHER ARISING OUT OF BREACH OF CONTRACT, WARRANTY, TORT (INCLUDING NEGLIGENCE AND STRICT LIABILITY)) OR UNDER OTHER THEORIES OF LAW OR EQUITY, OR WHERE THE THEORY OF LIABILITY IS BASED ON THE POSITION THAT THE PRODUCTS SHOULD HAVE EXCEEDED ANY STANDARDS IMPOSED BY APPLICABLE LAW, WITH RESPECT TO PRODUCTS SOLD BY SKYJACK, OR ANY UNDERTAKINGS, ACTS OR OMISSIONS RELATING THERETO. Without limiting the generality of the foregoing, Skyjack specifically disclaims any liability for property damage, penalties, special or punitive damages, damages for lost profits or revenues, down-time, lost good will, cost of capital, cost of substitute products or services, increased overhead, or for any other types of economic loss, or for claims of Buyer's customers or any third party for any such damages, costs or losses. **SKYJACK SHALL NOT BE LIABLE FOR AND DISCLAIMS ALL CONSEQUENTIAL, INCIDENTAL, INDIRECT AND CONTINGENT DAMAGES WHATSOEVER.**

This warranty shall be void if, upon the occurrence of any incident involving any products made by Skyjack and resulting in any personal injury or property damage, customer shall fail to notify Skyjack within 48 hours of such occurrence or permit Skyjack and its representatives to have immediate access to such products and all records of or within the control of customer relating to the products and occurrence. This warranty shall also be void if parts other than genuine Skyjack supplied parts (or parts authorized in writing by Skyjack) are used.

Buyer's rights hereunder are personal to the Buyer, and may not be transferred or assigned except with the prior written consent of Skyjack or by its authorized distributor as provided in a written distribution agreement between Skyjack and that distributor.

Skyjack requires that all OEM's manufacture and supply components and parts to Skyjack in conformity with all ANSI, CSA and/or other relevant industry standards. Skyjack will not be liable under this warranty or otherwise where the defect is the result of an OEM's failure to meet this requirement.

EXCEPT FOR THE LIMITED WARRANTY PROVIDED HEREIN, SKYJACK EXPRESSLY DISCLAIMS ANY AND ALL OTHER WARRANTIES (EXPRESS OR IMPLIED) AS TO THE PRODUCTS FURNISHED HEREUNDER, INCLUDING BUT NOT LIMITED TO ANY IMPLIED WARRANTIES AS TO MERCHANTABILITY OR FITNESS FOR ANY PARTICULAR PURPOSE.

Warranty Claim Procedures:

*SKYJACK INC., will repair or replace, at its option, the defective part or workmanship.

The selling distributor or authorized dealer shall be responsible for complete handling of customer claims under this warranty.

Here's what to do:

1. When providing notice of a claim under this warranty, contact Skyjack's Service Department to verify warranty coverage.
NOTE: The complete machine serial number is required to verify coverage.
2. When Skyjack's Service Department verifies warranty coverage, they will also issue a RA (Return Authorization) number for the return of the defective component(s). All items over \$100.00 in value must be returned to Skyjack Inc.
3. Fill out the warranty claim form.
4. The distributor/dealer should then file the warranty claim with Skyjack Inc. describing the nature of claimed defect, suspected cause, work performed, travel hours and labor hours.
5. Warranty labor will be paid at established hourly rates. The travel allowance will be paid at the same hourly rate; however, it is limited to a maximum of three hours. Labor rates and travel allowances are subject to change without notice.
6. If a part has serviceable components, PLEASE replace the bad component. For instance, if you have a bad switch on a controller, please replace the switch. Hydraulic cylinders should be repacked, unless they are damaged beyond repair.
7. Engine failures or Battery failures should be directed to your local distributor and would be covered, if at all, by that manufacturer's warranty. Be sure to record the Engine serial number.
8. Warranty claims received with insufficient information will be returned for correction and completion.
9. Materials returned for warranty inspection must comply with the following procedures:
 - A. Carefully packaged to prevent additional damage during shipping.
 - B. Drained of all contents and all open ports capped or plugged.
 - C. Shipped in a container tagged or marked with the RA number.
 - D. Shipped PREPAID. Any item(s) returned for warranty by any other means maybe refused and returned unless prior written approval from Skyjack is obtained.

Freight Damage:

Items shipped to the dealer will be sent freight prepaid and added to the invoice. If machines are received damaged it must be noted on the Bill of Lading prior to signing. The freight company must be contacted and a claim filed with the carrier. For more information contact Skyjack logistics at 1-519-837-0888. Failure to comply with the above procedures may delay approval and processing of warranty claims and could result in the denial of a warranty claim. Skyjack Customer(s) accounts must be kept current to approve and issue warranty credits. Skyjack reserves the right to withhold the issuance of credits to a Customer(s) if their account is not in good standing. This is subject to change without prior notice.