



The following documentation is an electronically-submitted vendor response to an advertised solicitation from the *West Virginia Purchasing Bulletin* within the Vendor Self-Service portal at [wvOASIS.gov](http://wvOASIS.gov). As part of the State of West Virginia's procurement process, and to maintain the transparency of the bid-opening process, this documentation submitted online is publicly posted by the West Virginia Purchasing Division at [WVPurchasing.gov](http://WVPurchasing.gov) with any other vendor responses to this solicitation submitted to the Purchasing Division in hard copy format.

Header 1

List View

General Information | Contact | Default Values | Discount | Document Information

Procurement Folder: 698164

SO Doc Code: CRFQ

Procurement Type: Central Purchase Order

SO Dept: 0803

Vendor ID: 000000201886

SO Doc ID: DOT2000000152

Legal Name: EASTERN VAULT COMPANY INC

Published Date: 3/19/20

Alias/DBA:

Close Date: 4/30/20

Total Bid: \$119,980.70

Close Time: 13:30

Response Date: 04/30/2020

Status: Closed

Response Time: 9:27

Solicitation Description: CONCRETE BOX BEAMS-HOPE STATION (07200898)

Total of Header Attachments: 1

Total of All Attachments: 1



Purchasing Division  
 2019 Washington Street East  
 Post Office Box 50130  
 Charleston, WV 25305-0130

**State of West Virginia  
 Solicitation Response**

**Proc Folder :** 698164  
**Solicitation Description :** CONCRETE BOX BEAMS-HOPE STATION (07200898)  
**Proc Type :** Central Purchase Order

Date issued	Solicitation Closes	Solicitation Response	Version
	2020-04-30 13:30:00	SR 0803 ESR0430200000006322	1

<b>VENDOR</b>
000000201886 EASTERN VAULT COMPANY INC

**Solicitation Number:** CRFQ 0803 DOT2000000152

**Total Bid :** \$119,980.70      **Response Date:** 2020-04-30      **Response Time:** 09:27:07

**Comments:**

**FOR INFORMATION CONTACT THE BUYER**  
 Crystal G Hustead  
 (304) 558-2402  
 crystal.g.hustead@wv.gov

<b>Signature on File</b>	<b>FEIN #</b>	<b>DATE</b>
--------------------------	---------------	-------------

All offers subject to all terms and conditions contained in this solicitation

Line	Comm Ln Desc	Qty	Unit Issue	Unit Price	Ln Total Or Contract Amount
1	1361 square feet - 27 Inch Interior Box Beam	1361.00000	SF	\$49.500000	\$67,369.50

Comm Code	Manufacturer	Specification	Model #
30101700			

**Extended Description :** Box beam shall be 6 pieces - each piece shall be 3 feet 0 inches x 75 feet 7 inches.

Line	Comm Ln Desc	Qty	Unit Issue	Unit Price	Ln Total Or Contract Amount
2	454 square feet - 27 Inch Exterior Box Beam	454.00000	SF	\$62.800000	\$28,511.20

Comm Code	Manufacturer	Specification	Model #
30101700			

**Extended Description :** Box beam shall be two pieces - each piece shall be 3 feet 0 inches x 75 feet 7 inches.

Line	Comm Ln Desc	Qty	Unit Issue	Unit Price	Ln Total Or Contract Amount
3	Elastomeric laminated bearing pads (b-1)	14.00000	EA	\$200.000000	\$2,800.00

Comm Code	Manufacturer	Specification	Model #
30101700			

**Extended Description :** Pads must be 1-13/16 inches X 4 3/4 inches X 28 inches

Line	Comm Ln Desc	Qty	Unit Issue	Unit Price	Ln Total Or Contract Amount
4	Swedged anchor bolt or #8 deformed rebar	16.00000	EA	\$10.000000	\$160.00

Comm Code	Manufacturer	Specification	Model #
30101700			

**Extended Description :** Bolt or rebar must be 1 inch X 2 foot 0 inches

Line	Comm Ln Desc	Qty	Unit Issue	Unit Price	Ln Total Or Contract Amount
5	Sponge rubber preformed joint filler	2.00000	EA	\$20.000000	\$40.00

Comm Code	Manufacturer	Specification	Model #
30101700			

**Extended Description :** Joint filler must be 1 inch thick. Joint filler must be 24 feet 5-1/4 inches X 2 feet 4 inches.

Line	Comm Ln Desc	Qty	Unit Issue	Unit Price	Ln Total Or Contract Amount
6	Sponge rubber preformed joint filler	4.00000	EA	\$30.000000	\$120.00

Comm Code	Manufacturer	Specification	Model #
30101700			

**Extended Description :** Joint filler must be 2 inches thick. Joint filler must be 4 -3/4 inches X 6-7/8 Inches.

Line	Comm Ln Desc	Qty	Unit Issue	Unit Price	Ln Total Or Contract Amount
7	Sponge rubber preformed joint filler	12.00000	EA	\$30.000000	\$360.00

Comm Code	Manufacturer	Specification	Model #
30101700			

**Extended Description :** Joint filler must be 2 inches thick. Joint filler must be 4-3/4 inches X 8-3/4 inches.

Line	Comm Ln Desc	Qty	Unit Issue	Unit Price	Ln Total Or Contract Amount
8	Sponge rubber preformed joint filler	16.00000	EA	\$30.000000	\$480.00

Comm Code	Manufacturer	Specification	Model #
30101700			

**Extended Description :** Joint filler must be 2 inches thick. Joint filler must be 6-5/8 inches X 3 feet 0-7/8 inches.

Line	Comm Ln Desc	Qty	Unit Issue	Unit Price	Ln Total Or Contract Amount
9	Sponge rubber washer	49.00000	EA	\$10.000000	\$490.00

Comm Code	Manufacturer	Specification	Model #
30101700			

**Extended Description :** Washers must have a 3 1/2 inch holes. Washer must be 8 inches X 8 inches X 1 inch thick.

Line	Comm Ln Desc	Qty	Unit Issue	Unit Price	Ln Total Or Contract Amount
10	Bridge Rail	137.50000	LF	\$100.000000	\$13,750.00

Comm Code	Manufacturer	Specification	Model #
30121703			

**Extended Description :** Bridge rail must conform to standards set forth in section 607 of the WVDOH Standard Specifications of Roads and Bridges. Bridge rail must include inserts, hardware, posts and guardrail (see plans for detail). Bridge rail must be attached to beams by fabricator.

Line	Comm Ln Desc	Qty	Unit Issue	Unit Price	Ln Total Or Contract Amount
11	Post tension bearing plates	14.00000	EA	\$50.000000	\$700.00

Comm Code	Manufacturer	Specification	Model #
30101700			

**Extended Description :** 14 plates shall be 9 inches X 9 inches X 1 inch thick;

Line	Comm Ln Desc	Qty	Unit Issue	Unit Price	Ln Total Or Contract Amount
12	Post Tension Bar	192.00000	LF	\$18.750000	\$3,600.00

Comm Code	Manufacturer	Specification	Model #
30101700			

**Extended Description :** The post tension bar must be 1 inch diameter and include nuts. There shall be 7 pieces each measuring 27 feet 5-1/4 inches long;

Line	Comm Ln Desc	Qty	Unit Issue	Unit Price	Ln Total Or Contract Amount
13	Asymmetrical Thrie Beam Transition Section	4.00000	EA	\$225.000000	\$900.00

Comm Code	Manufacturer	Specification	Model #
30101700			

**Extended Description :** Each beam shall be 6 feet 3 inches and the total quantity shall be 4. Transition sections must be supplied but NOT attached.

Line	Comm Ln Desc	Qty	Unit Issue	Unit Price	Ln Total Or Contract Amount
14	Elastomeric laminated bearing pads (b-2)	4.00000	EA	\$175.000000	\$700.00

Comm Code	Manufacturer	Specification	Model #
30101700			

**Extended Description :** Pads must be 1-13/16 inches X 4 3/4 inches X 15 1/2 inches



Purchasing Division  
 2019 Washington Street East  
 Post Office Box 50130  
 Charleston, WV 25305-0130

State of West Virginia  
 Request for Quotation  
 19 - Highways

Proc Folder: 698164

Doc Description: CONCRETE BOX BEAMS-HOPE STATION (07200898)

Proc Type: Central Purchase Order

Date Issued	Solicitation Closes	Solicitation No	Version
2020-03-19	2020-04-30 13:30:00	CRFQ 0803 DOT2000000152	1

**BID RECEIVING LOCATION**

BID CLERK  
 DEPARTMENT OF ADMINISTRATION  
 PURCHASING DIVISION  
 2019 WASHINGTON ST E  
 CHARLESTON WV 25305  
 US

**VENDOR**

Vendor Name, Address and Telephone Number:

EASTERN VAULT CO., INC.  
 PO Box 1134  
 PRINCETON WV 24740 304-425-8955

**FOR INFORMATION CONTACT THE BUYER**

Crystal G Hustead  
 (304) 558-2402  
 crystal.g.hustead@wv.gov

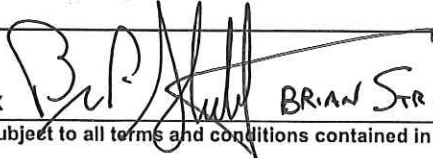
Signature X  BRIAN STRUBE FEIN # 55-0520255 DATE 4-27-2020

All offers subject to all terms and conditions contained in this solicitation



**ADDITIONAL INFORMATION:**

THE STATE OF WEST VIRGINIA PURCHASING DIVISION FOR THE AGENCY, WEST VIRGINIA DIVISION OF HIGHWAYS, IS SOLICITING BIDS TO ESTABLISH A CONTRACT FOR THE ONE-TIME PURCHASE OF CONCRETE BOX BEAMS, BRIDGE RAIL, AND COMPONENTS PER THE ATTACHED DOCUMENTS.

\*\*\*QUESTIONS REGARDING THE SOLICITATION MUST BE SUBMITTED IN WRITING TO CRYSTAL.G.HUSTEAD@WV.GOV PRIOR TO THE QUESTION PERIOD DEADLINE CONTAINED IN THE INSTRUCTIONS TO VENDORS SUBMITTING BIDS\*\*\*

INVOICE TO		SHIP TO	
DIVISION OF HIGHWAYS DISTRICT SEVEN DRAWER 1228		STATE OF WEST VIRGINIA JOBSITE - SEE SPECIFICATIONS	
WESTON	WV26452	No City	WV 99999
US		US	

Line	Comm Ln Desc	Qty	Unit Issue	Unit Price	Total Price
1	1361 square feet - 27 Inch Interior Box Beam	1361.00000	SF		

Comm Code	Manufacturer	Specification	Model #
30101700			

**Extended Description :**

Box beam shall be 6 pieces - each piece shall be 3 feet 0 inches x 75 feet 7 inches.

INVOICE TO		SHIP TO	
DIVISION OF HIGHWAYS DISTRICT SEVEN DRAWER 1228		STATE OF WEST VIRGINIA JOBSITE - SEE SPECIFICATIONS	
WESTON	WV26452	No City	WV 99999
US		US	

Line	Comm Ln Desc	Qty	Unit Issue	Unit Price	Total Price
2	454 square feet - 27 Inch Exterior Box Beam	454.00000	SF		

Comm Code	Manufacturer	Specification	Model #
30101700			

**Extended Description :**

Box beam shall be two pieces - each piece shall be 3 feet 0 inches x 75 feet 7 inches.

INVOICE TO		SHIP TO	
DIVISION OF HIGHWAYS DISTRICT SEVEN DRAWER 1228		STATE OF WEST VIRGINIA JOBSITE - SEE SPECIFICATIONS	
WESTON	WV26452	No City	WV 99999
US		US	

Line	Comm Ln Desc	Qty	Unit Issue	Unit Price	Total Price
3	Elastomeric laminated bearing pads (b-1)	14.00000	EA		

Comm Code	Manufacturer	Specification	Model #
30101700			

Extended Description :  
Pads must be 1-13/16 inches X 4 3/4 inches X 28 inches

INVOICE TO		SHIP TO	
DIVISION OF HIGHWAYS DISTRICT SEVEN DRAWER 1228		STATE OF WEST VIRGINIA JOBSITE - SEE SPECIFICATIONS	
WESTON	WV26452	No City	WV 99999
US		US	

Line	Comm Ln Desc	Qty	Unit Issue	Unit Price	Total Price
4	Swedged anchor bolt or #8 deformed rebar	16.00000	EA		

Comm Code	Manufacturer	Specification	Model #
30101700			

Extended Description :  
Bolt or rebar must be 1 inch X 2 foot 0 inches

INVOICE TO		SHIP TO	
DIVISION OF HIGHWAYS DISTRICT SEVEN DRAWER 1228		STATE OF WEST VIRGINIA JOBSITE - SEE SPECIFICATIONS	
WESTON	WV26452	No City	WV 99999
US		US	

Line	Comm Ln Desc	Qty	Unit Issue	Unit Price	Total Price
5	Sponge rubber preformed joint filler	2.00000	EA		

Comm Code	Manufacturer	Specification	Model #
30101700			

**Extended Description :**

Joint filler must be 1 inch thick. Joint filler must be 24 feet 5-1/4 inches X 2 feet 4 inches.

INVOICE TO		SHIP TO	
DIVISION OF HIGHWAYS DISTRICT SEVEN DRAWER 1228 WESTON WV26452 US		STATE OF WEST VIRGINIA JOBSITE - SEE SPECIFICATIONS No City WV 99999 US	

Line	Comm Ln Desc	Qty	Unit Issue	Unit Price	Total Price
6	Sponge rubber preformed joint filler	4.00000	EA		

Comm Code	Manufacturer	Specification	Model #
30101700			

**Extended Description :**

Joint filler must be 2 inches thick. Joint filler must be 4 -3/4 inches X 6-7/8 Inches.

INVOICE TO		SHIP TO	
DIVISION OF HIGHWAYS DISTRICT SEVEN DRAWER 1228 WESTON WV26452 US		STATE OF WEST VIRGINIA JOBSITE - SEE SPECIFICATIONS No City WV 99999 US	

Line	Comm Ln Desc	Qty	Unit Issue	Unit Price	Total Price
7	Sponge rubber preformed joint filler	12.00000	EA		

Comm Code	Manufacturer	Specification	Model #
30101700			

**Extended Description :**

Joint filler must be 2 inches thick. Joint filler must be 4-3/4 inches X 8-3/4 inches.

INVOICE TO		SHIP TO	
DIVISION OF HIGHWAYS DISTRICT SEVEN DRAWER 1228		STATE OF WEST VIRGINIA JOBSITE - SEE SPECIFICATIONS	
WESTON	WV26452	No City	WV 99999
US		US	

Line	Comm Ln Desc	Qty	Unit Issue	Unit Price	Total Price
8	Sponge rubber preformed joint filler	16.00000	EA		

Comm Code	Manufacturer	Specification	Model #
30101700			

Extended Description :  
Joint filler must be 2 inches thick. Joint filler must be 6-5/8 inches X 3 feet 0-7/8 inches.

INVOICE TO		SHIP TO	
DIVISION OF HIGHWAYS DISTRICT SEVEN DRAWER 1228		STATE OF WEST VIRGINIA JOBSITE - SEE SPECIFICATIONS	
WESTON	WV26452	No City	WV 99999
US		US	

Line	Comm Ln Desc	Qty	Unit Issue	Unit Price	Total Price
9	Sponge rubber washer	49.00000	EA		

Comm Code	Manufacturer	Specification	Model #
30101700			

Extended Description :  
Washers must have a 3 1/2 inch holes. Washer must be 8 inches X 8 inches X 1 inch thick.

INVOICE TO		SHIP TO	
DIVISION OF HIGHWAYS DISTRICT SEVEN DRAWER 1228		STATE OF WEST VIRGINIA JOBSITE - SEE SPECIFICATIONS	
WESTON	WV26452	No City	WV 99999
US		US	

Line	Comm Ln Desc	Qty	Unit Issue	Unit Price	Total Price
10	Bridge Rail	137.50000	LF		

Comm Code	Manufacturer	Specification	Model #
30121703			

**Extended Description :**

Bridge rail must conform to standards set forth in section 607 of the WVDOH Standard Specifications of Roads and Bridges. Bridge rail must include inserts, hardware, posts and guardrail (see plans for detail). Bridge rail must be attached to beams by fabricator.

INVOICE TO		SHIP TO	
DIVISION OF HIGHWAYS DISTRICT SEVEN DRAWER 1228		STATE OF WEST VIRGINIA JOBSITE - SEE SPECIFICATIONS	
WESTON	WV26452	No City	WV 99999
US		US	

Line	Comm Ln Desc	Qty	Unit Issue	Unit Price	Total Price
11	Post tension bearing plates	14.00000	EA		

Comm Code	Manufacturer	Specification	Model #
30101700			

**Extended Description :**

14 plates shall be 9 inches X 9 inches X 1 inch thick;

INVOICE TO		SHIP TO	
DIVISION OF HIGHWAYS DISTRICT SEVEN DRAWER 1228		STATE OF WEST VIRGINIA JOBSITE - SEE SPECIFICATIONS	
WESTON	WV26452	No City	WV 99999
US		US	

Line	Comm Ln Desc	Qty	Unit Issue	Unit Price	Total Price
12	Post Tension Bar	192.00000	LF		

Comm Code	Manufacturer	Specification	Model #
30101700			

**Extended Description :**

The post tension bar must be 1 inch diameter and include nuts. There shall be 7 pieces each measuring 27 feet 5-1/4 inches long;

INVOICE TO		SHIP TO	
DIVISION OF HIGHWAYS DISTRICT SEVEN DRAWER 1228		STATE OF WEST VIRGINIA JOBSITE - SEE SPECIFICATIONS	
WESTON	WV26452	No City	WV 99999
US		US	

Line	Comm Ln Desc	Qty	Unit Issue	Unit Price	Total Price
13	Asymmetrical Thrie Beam Transition Section	4.00000	EA		

Comm Code	Manufacturer	Specification	Model #
30101700			

Extended Description :  
Each beam shall be 6 feet 3 inches and the total quantity shall be 4. Transition sections must be supplied but NOT attached.

INVOICE TO		SHIP TO	
DIVISION OF HIGHWAYS DISTRICT SEVEN DRAWER 1228		STATE OF WEST VIRGINIA JOBSITE - SEE SPECIFICATIONS	
WESTON	WV26452	No City	WV 99999
US		US	

Line	Comm Ln Desc	Qty	Unit Issue	Unit Price	Total Price
14	Elastomeric laminated bearing pads (b-2)	4.00000	EA		

Comm Code	Manufacturer	Specification	Model #
30101700			

Extended Description :  
Pads must be 1-13/16 inches X 4 3/4 inches X 15 1/2 inches

**SCHEDULE OF EVENTS**

Line	Event	Event Date
1	VENDOR QUESTION DEADLINE	2020-04-17

## INSTRUCTIONS TO VENDORS SUBMITTING BIDS

**1. REVIEW DOCUMENTS THOROUGHLY:** The attached documents contain a solicitation for bids. Please read these instructions and all documents attached in their entirety. These instructions provide critical information about requirements that if overlooked could lead to disqualification of a Vendor's bid. All bids must be submitted in accordance with the provisions contained in these instructions and the Solicitation. Failure to do so may result in disqualification of Vendor's bid.

**2. MANDATORY TERMS:** The Solicitation may contain mandatory provisions identified by the use of the words "must," "will," and "shall." Failure to comply with a mandatory term in the Solicitation will result in bid disqualification.

**3. PREBID MEETING:** The item identified below shall apply to this Solicitation.

A pre-bid meeting will not be held prior to bid opening

A **MANDATORY PRE-BID** meeting will be held at the following place and time:

All Vendors submitting a bid must attend the mandatory pre-bid meeting. Failure to attend the mandatory pre-bid meeting shall result in disqualification of the Vendor's bid. No one individual is permitted to represent more than one vendor at the pre-bid meeting. Any individual that does attempt to represent two or more vendors will be required to select one vendor to which the individual's attendance will be attributed. The vendors not selected will be deemed to have not attended the pre-bid meeting unless another individual attended on their behalf.

An attendance sheet provided at the pre-bid meeting shall serve as the official document verifying attendance. Any person attending the pre-bid meeting on behalf of a Vendor must list on the attendance sheet his or her name and the name of the Vendor he or she is representing.

Additionally, the person attending the pre-bid meeting should include the Vendor's E-Mail address, phone number, and Fax number on the attendance sheet. It is the Vendor's responsibility to locate the attendance sheet and provide the required information. Failure to complete the attendance sheet as required may result in disqualification of Vendor's bid.

All Vendors should arrive prior to the starting time for the pre-bid. Vendors who arrive after the starting time but prior to the end of the pre-bid will be permitted to sign in but are charged with knowing all matters discussed at the pre-bid.

Questions submitted at least five business days prior to a scheduled pre-bid will be discussed at the pre-bid meeting if possible. Any discussions or answers to questions at the pre-bid meeting  
Revised 01/09/2020

are preliminary in nature and are non-binding. Official and binding answers to questions will be published in a written addendum to the Solicitation prior to bid opening.

**4. VENDOR QUESTION DEADLINE:** Vendors may submit questions relating to this Solicitation to the Purchasing Division. Questions must be submitted in writing. All questions must be submitted on or before the date listed below and to the address listed below in order to be considered. A written response will be published in a Solicitation addendum if a response is possible and appropriate. Non-written discussions, conversations, or questions and answers regarding this Solicitation are preliminary in nature and are nonbinding.

Submitted e-mails should have solicitation number in the subject line.

Question Submission Deadline: April 17, 2020 at 10:00 AM

Submit Questions to: Crystal Husted  
2019 Washington Street, East  
Charleston, WV 25305  
Fax: (304) 558-4115 (Vendors should not use this fax number for bid submission)  
Email: Crystal.G.Husted@wv.gov

**5. VERBAL COMMUNICATION:** Any verbal communication between the Vendor and any State personnel is not binding, including verbal communication at the mandatory pre-bid conference. Only information issued in writing and added to the Solicitation by an official written addendum by the Purchasing Division is binding.

**6. BID SUBMISSION:** All bids must be submitted electronically through wvOASIS or signed and delivered by the Vendor to the Purchasing Division at the address listed below on or before the date and time of the bid opening. Any bid received by the Purchasing Division staff is considered to be in the possession of the Purchasing Division and will not be returned for any reason. The Purchasing Division will not accept bids, modification of bids, or addendum acknowledgment forms via e-mail. Acceptable delivery methods include electronic submission via wvOASIS, hand delivery, delivery by courier, or facsimile.

The bid delivery address is:  
Department of Administration, Purchasing Division  
2019 Washington Street East  
Charleston, WV 25305-0130

A bid that is not submitted electronically through wvOASIS should contain the information listed below on the face of the envelope or the bid may be rejected by the Purchasing Division.:

SEALED BID:  
BUYER: Crystal Husted  
SOLICITATION NO.: CRFQ DOT2000000152  
BID OPENING DATE: April 30, 2020  
BID OPENING TIME: 1:30 PM  
FAX NUMBER: 304-558-3970

Revised 01/09/2020



The Purchasing Division may prohibit the submission of bids electronically through wvOASIS at its sole discretion. Such a prohibition will be contained and communicated in the wvOASIS system resulting in the Vendor's inability to submit bids through wvOASIS. Submission of a response to an Expression or Interest or Request for Proposal is not permitted in wvOASIS.

**For Request For Proposal ("RFP") Responses Only:** In the event that Vendor is responding to a request for proposal, the Vendor shall submit one original technical and one original cost proposal plus       n/a       convenience copies of each to the Purchasing Division at the address shown above. Additionally, the Vendor should identify the bid type as either a technical or cost proposal on the face of each bid envelope submitted in response to a request for proposal as follows:

**BID TYPE:** (This only applies to CRFP)

- Technical
- Cost

**7. BID OPENING:** Bids submitted in response to this Solicitation will be opened at the location identified below on the date and time listed below. Delivery of a bid after the bid opening date and time will result in bid disqualification. For purposes of this Solicitation, a bid is considered delivered when confirmation of delivery is provided by wvOASIS (in the case of electronic submission) or when the bid is time stamped by the official Purchasing Division time clock (in the case of hand delivery).

**Bid Opening Date and Time:** April 30, 2020 at 1:30 PM

**Bid Opening Location:** Department of Administration, Purchasing Division  
2019 Washington Street East  
Charleston, WV 25305-0130

**8. ADDENDUM ACKNOWLEDGEMENT:** Changes or revisions to this Solicitation will be made by an official written addendum issued by the Purchasing Division. Vendor should acknowledge receipt of all addenda issued with this Solicitation by completing an Addendum Acknowledgment Form, a copy of which is included herewith. Failure to acknowledge addenda may result in bid disqualification. The addendum acknowledgement should be submitted with the bid to expedite document processing.

**9. BID FORMATTING:** Vendor should type or electronically enter the information onto its bid to prevent errors in the evaluation. Failure to type or electronically enter the information may result in bid disqualification.

**10. ALTERNATE MODEL OR BRAND:** Unless the box below is checked, any model, brand, or specification listed in this Solicitation establishes the acceptable level of quality only and is not intended to reflect a preference for, or in any way favor, a particular brand or vendor. Vendors may bid alternates to a listed model or brand provided that the alternate is at least equal to the model or brand and complies with the required specifications. The equality of any alternate being bid shall be determined by the State at its sole discretion. Any Vendor bidding an alternate model or brand should clearly identify the alternate items in its bid and should include manufacturer's specifications, industry literature, and/or any other relevant documentation demonstrating the

equality of the alternate items. Failure to provide information for alternate items may be grounds for rejection of a Vendor's bid.

This Solicitation is based upon a standardized commodity established under W. Va. Code § 5A-3-61. Vendors are expected to bid the standardized commodity identified. Failure to bid the standardized commodity will result in your firm's bid being rejected.

**11. EXCEPTIONS AND CLARIFICATIONS:** The Solicitation contains the specifications that shall form the basis of a contractual agreement. Vendor shall clearly mark any exceptions, clarifications, or other proposed modifications in its bid. Exceptions to, clarifications of, or modifications of a requirement or term and condition of the Solicitation may result in bid disqualification.

**12. COMMUNICATION LIMITATIONS:** In accordance with West Virginia Code of State Rules §148-1-6.6, communication with the State of West Virginia or any of its employees regarding this Solicitation during the solicitation, bid, evaluation or award periods, except through the Purchasing Division, is strictly prohibited without prior Purchasing Division approval. Purchasing Division approval for such communication is implied for all agency delegated and exempt purchases.

**13. REGISTRATION:** Prior to Contract award, the apparent successful Vendor must be properly registered with the West Virginia Purchasing Division and must have paid the \$125 fee, if applicable.

**14. UNIT PRICE:** Unit prices shall prevail in cases of a discrepancy in the Vendor's bid.

**15. PREFERENCE:** Vendor Preference may be requested in purchases of motor vehicles or construction and maintenance equipment and machinery used in highway and other infrastructure projects. Any request for preference must be submitted in writing with the bid, must specifically identify the preference requested with reference to the applicable subsection of West Virginia Code § 5A-3-37, and must include with the bid any information necessary to evaluate and confirm the applicability of the requested preference. A request form to help facilitate the request can be found at:

<http://www.state.wv.us/admin/purchase/vrc/Venpref.pdf>.

**15A. RECIPROCAL PREFERENCE:** The State of West Virginia applies a reciprocal preference to all solicitations for commodities and printing in accordance with W. Va. Code § 5A-3-37(b). In effect, non-resident vendors receiving a preference in their home states, will see that same preference granted to West Virginia resident vendors bidding against them in West Virginia. Any request for reciprocal preference must include with the bid any information necessary to evaluate and confirm the applicability of the preference. A request form to help facilitate the request can be found at: <http://www.state.wv.us/admin/purchase/vrc/Venpref.pdf>.

**16. SMALL, WOMEN-OWNED, OR MINORITY-OWNED BUSINESSES:** For any solicitations publicly advertised for bid, in accordance with West Virginia Code §5A-3-37(a)(7) and W. Va. CSR § 148-22-9, any non-resident vendor certified as a small, women-owned, or minority-owned business under W. Va. CSR § 148-22-9 shall be provided the same preference made available to any resident vendor. Any non-resident small, women-owned, or

minority-owned business must identify itself as such in writing, must submit that writing to the Purchasing Division with its bid, and must be properly certified under W. Va. CSR § 148-22-9 prior to contract award to receive the preferences made available to resident vendors. Preference for a non-resident small, women-owned, or minority owned business shall be applied in accordance with W. Va. CSR § 148-22-9.

**17. WAIVER OF MINOR IRREGULARITIES:** The Director reserves the right to waive minor irregularities in bids or specifications in accordance with West Virginia Code of State Rules § 148-1-4.6.

**18. ELECTRONIC FILE ACCESS RESTRICTIONS:** Vendor must ensure that its submission in wvOASIS can be accessed and viewed by the Purchasing Division staff immediately upon bid opening. The Purchasing Division will consider any file that cannot be immediately accessed and viewed at the time of the bid opening (such as, encrypted files, password protected files, or incompatible files) to be blank or incomplete as context requires, and are therefore unacceptable. A vendor will not be permitted to unencrypt files, remove password protections, or resubmit documents after bid opening to make a file viewable if those documents are required with the bid. A Vendor may be required to provide document passwords or remove access restrictions to allow the Purchasing Division to print or electronically save documents provided that those documents are viewable by the Purchasing Division prior to obtaining the password or removing the access restriction.

**19. NON-RESPONSIBLE:** The Purchasing Division Director reserves the right to reject the bid of any vendor as Non-Responsible in accordance with W. Va. Code of State Rules § 148-1-5.3, when the Director determines that the vendor submitting the bid does not have the capability to fully perform, or lacks the integrity and reliability to assure good-faith performance.”

**20. ACCEPTANCE/REJECTION:** The State may accept or reject any bid in whole, or in part in accordance with W. Va. Code of State Rules § 148-1-4.5. and § 148-1-6.4.b.”

**21. YOUR SUBMISSION IS A PUBLIC DOCUMENT:** Vendor’s entire response to the Solicitation and the resulting Contract are public documents. As public documents, they will be disclosed to the public following the bid/proposal opening or award of the contract, as required by the competitive bidding laws of West Virginia Code §§ 5A-3-1 et seq., 5-22-1 et seq., and 5G-1-1 et seq. and the Freedom of Information Act West Virginia Code §§ 29B-1-1 et seq.

**DO NOT SUBMIT MATERIAL YOU CONSIDER TO BE CONFIDENTIAL, A TRADE SECRET, OR OTHERWISE NOT SUBJECT TO PUBLIC DISCLOSURE.**

Submission of any bid, proposal, or other document to the Purchasing Division constitutes your explicit consent to the subsequent public disclosure of the bid, proposal, or document. The Purchasing Division will disclose any document labeled “confidential,” “proprietary,” “trade secret,” “private,” or labeled with any other claim against public disclosure of the documents, to include any “trade secrets” as defined by West Virginia Code § 47-22-1 et seq. All submissions are subject to public disclosure without notice.

**22. INTERESTED PARTY DISCLOSURE:** West Virginia Code § 6D-1-2 requires that the vendor submit to the Purchasing Division a disclosure of interested parties to the contract for all contracts with an actual or estimated value of at least \$1 Million. That disclosure must occur on the form prescribed and approved by the WV Ethics Commission prior to contract award. A copy of that form is included with this solicitation or can be obtained from the WV Ethics Commission. This requirement does not apply to publicly traded companies listed on a national or international stock exchange. A more detailed definition of interested parties can be obtained from the form referenced above.

**23. WITH THE BID REQUIREMENTS:** In instances where these specifications require documentation or other information with the bid, and a vendor fails to provide it with the bid, the Director of the Purchasing Division reserves the right to request those items after bid opening and prior to contract award pursuant to the authority to waive minor irregularities in bids or specifications under W. Va. CSR § 148-1-4.6. This authority does not apply to instances where state law mandates receipt with the bid.

## GENERAL TERMS AND CONDITIONS:

**1. CONTRACTUAL AGREEMENT:** Issuance of a Award Document signed by the Purchasing Division Director, or his designee, and approved as to form by the Attorney General's office constitutes acceptance of this Contract made by and between the State of West Virginia and the Vendor. Vendor's signature on its bid signifies Vendor's agreement to be bound by and accept the terms and conditions contained in this Contract.

**2. DEFINITIONS:** As used in this Solicitation/Contract, the following terms shall have the meanings attributed to them below. Additional definitions may be found in the specifications included with this Solicitation/Contract.

**2.1. "Agency" or "Agencies"** means the agency, board, commission, or other entity of the State of West Virginia that is identified on the first page of the Solicitation or any other public entity seeking to procure goods or services under this Contract.

**2.2. "Bid" or "Proposal"** means the vendors submitted response to this solicitation.

**2.3. "Contract"** means the binding agreement that is entered into between the State and the Vendor to provide the goods or services requested in the Solicitation.

**2.4. "Director"** means the Director of the West Virginia Department of Administration, Purchasing Division.

**2.5. "Purchasing Division"** means the West Virginia Department of Administration, Purchasing Division.

**2.6. "Award Document"** means the document signed by the Agency and the Purchasing Division, and approved as to form by the Attorney General, that identifies the Vendor as the contract holder.

**2.7. "Solicitation"** means the official notice of an opportunity to supply the State with goods or services that is published by the Purchasing Division.

**2.8. "State"** means the State of West Virginia and/or any of its agencies, commissions, boards, etc. as context requires.

**2.9. "Vendor" or "Vendors"** means any entity submitting a bid in response to the Solicitation, the entity that has been selected as the lowest responsible bidder, or the entity that has been awarded the Contract as context requires.

**3. CONTRACT TERM; RENEWAL; EXTENSION:** The term of this Contract shall be determined in accordance with the category that has been identified as applicable to this Contract below:

**Term Contract**

**Initial Contract Term:** **Initial Contract Term:** This Contract becomes effective on \_\_\_\_\_ and extends for a period of \_\_\_\_\_ year(s).

**Renewal Term:** This Contract may be renewed upon the mutual written consent of the Agency, and the Vendor, with approval of the Purchasing Division and the Attorney General's office (Attorney General approval is as to form only). Any request for renewal should be delivered to the Agency and then submitted to the Purchasing Division thirty (30) days prior to the expiration date of the initial contract term or appropriate renewal term. A Contract renewal shall be in accordance with the terms and conditions of the original contract. Unless otherwise specified below, renewal of this Contract is limited to \_\_\_\_\_ successive one (1) year periods or multiple renewal periods of less than one year, provided that the multiple renewal periods do not exceed the total number of months available in all renewal years combined. Automatic renewal of this Contract is prohibited. Renewals must be approved by the Vendor, Agency, Purchasing Division and Attorney General's office (Attorney General approval is as to form only)

**Alternate Renewal Term** – This contract may be renewed for \_\_\_\_\_ successive \_\_\_\_\_ year periods or shorter periods provided that they do not exceed the total number of months contained in all available renewals. Automatic renewal of this Contract is prohibited. Renewals must be approved by the Vendor, Agency, Purchasing Division and Attorney General's office (Attorney General approval is as to form only)

**Delivery Order Limitations:** In the event that this contract permits delivery orders, a delivery order may only be issued during the time this Contract is in effect. Any delivery order issued within one year of the expiration of this Contract shall be effective for one year from the date the delivery order is issued. No delivery order may be extended beyond one year after this Contract has expired.

**Fixed Period Contract:** This Contract becomes effective upon Vendor's receipt of the notice to proceed and must be completed within \_\_\_\_\_ days.

**Fixed Period Contract with Renewals:** This Contract becomes effective upon Vendor's receipt of the notice to proceed and part of the Contract more fully described in the attached specifications must be completed within \_\_\_\_\_ days. Upon completion of the work covered by the preceding sentence, the vendor agrees that maintenance, monitoring, or warranty services will be provided for \_\_\_\_\_ year(s) thereafter.

**One Time Purchase:** The term of this Contract shall run from the issuance of the Award Document until all of the goods contracted for have been delivered, but in no event will this Contract extend for more than one fiscal year.

**Other:** See attached.

**4. NOTICE TO PROCEED:** Vendor shall begin performance of this Contract immediately upon receiving notice to proceed unless otherwise instructed by the Agency. Unless otherwise specified, the fully executed Award Document will be considered notice to proceed.

**5. QUANTITIES:** The quantities required under this Contract shall be determined in accordance with the category that has been identified as applicable to this Contract below.

**Open End Contract:** Quantities listed in this Solicitation are approximations only, based on estimates supplied by the Agency. It is understood and agreed that the Contract shall cover the quantities actually ordered for delivery during the term of the Contract, whether more or less than the quantities shown.

**Service:** The scope of the service to be provided will be more clearly defined in the specifications included herewith.

**Combined Service and Goods:** The scope of the service and deliverable goods to be provided will be more clearly defined in the specifications included herewith.

**One Time Purchase:** This Contract is for the purchase of a set quantity of goods that are identified in the specifications included herewith. Once those items have been delivered, no additional goods may be procured under this Contract without an appropriate change order approved by the Vendor, Agency, Purchasing Division, and Attorney General's office.

**6. EMERGENCY PURCHASES:** The Purchasing Division Director may authorize the Agency to purchase goods or services in the open market that Vendor would otherwise provide under this Contract if those goods or services are for immediate or expedited delivery in an emergency. Emergencies shall include, but are not limited to, delays in transportation or an unanticipated increase in the volume of work. An emergency purchase in the open market, approved by the Purchasing Division Director, shall not constitute of breach of this Contract and shall not entitle the Vendor to any form of compensation or damages. This provision does not excuse the State from fulfilling its obligations under a One Time Purchase contract.

**7. REQUIRED DOCUMENTS:** All of the items checked below must be provided to the Purchasing Division by the Vendor as specified below.

**BID BOND (Construction Only):** Pursuant to the requirements contained in W. Va. Code § 5-22-1(c), All Vendors submitting a bid on a construction project shall furnish a valid bid bond in the amount of five percent (5%) of the total amount of the bid protecting the State of West Virginia. The bid bond must be submitted with the bid.

**PERFORMANCE BOND:** The apparent successful Vendor shall provide a performance bond in the amount of 100% of the contract. The performance bond must be received by the Purchasing Division prior to Contract award.

**LABOR/MATERIAL PAYMENT BOND:** The apparent successful Vendor shall provide a labor/material payment bond in the amount of 100% of the Contract value. The labor/material payment bond must be delivered to the Purchasing Division prior to Contract award.

In lieu of the Bid Bond, Performance Bond, and Labor/Material Payment Bond, the Vendor may provide certified checks, cashier's checks, or irrevocable letters of credit. Any certified check, cashier's check, or irrevocable letter of credit provided in lieu of a bond must be of the same amount and delivered on the same schedule as the bond it replaces. A letter of credit submitted in lieu of a performance and labor/material payment bond will only be allowed for projects under \$100,000. Personal or business checks are not acceptable. Notwithstanding the foregoing, West Virginia Code § 5-22-1 (d) mandates that a vendor provide a performance and labor/material payment bond for construction projects. Accordingly, substitutions for the performance and labor/material payment bonds for construction projects is not permitted.

**MAINTENANCE BOND:** The apparent successful Vendor shall provide a two (2) year maintenance bond covering the roofing system. The maintenance bond must be issued and delivered to the Purchasing Division prior to Contract award.

**LICENSE(S) / CERTIFICATIONS / PERMITS:** In addition to anything required under the Section of the General Terms and Conditions entitled Licensing, the apparent successful Vendor shall furnish proof of the following licenses, certifications, and/or permits upon request and in a form acceptable to the State. The request may be prior to or after contract award at the State's sole discretion.

The apparent successful Vendor shall also furnish proof of any additional licenses or certifications contained in the specifications regardless of whether or not that requirement is listed above.



**8. INSURANCE:** The apparent successful Vendor shall furnish proof of the insurance identified by a checkmark below and must include the State as an additional insured on each policy prior to Contract award. The insurance coverages identified below must be maintained throughout the life of this contract. Thirty (30) days prior to the expiration of the insurance policies, Vendor shall provide the Agency with proof that the insurance mandated herein has been continued. Vendor must also provide Agency with immediate notice of any changes in its insurance policies, including but not limited to, policy cancelation, policy reduction, or change in insurers. The apparent successful Vendor shall also furnish proof of any additional insurance requirements contained in the specifications prior to Contract award regardless of whether or not that insurance requirement is listed in this section.

Vendor must maintain:

**Commercial General Liability Insurance** in at least an amount of: \$80,000-\*\*\*See Below per occurrence.

**Automobile Liability Insurance** in at least an amount of: \_\_\_\_\_ per occurrence.

**Professional/Malpractice/Errors and Omission Insurance** in at least an amount of: \_\_\_\_\_ per occurrence. Notwithstanding the forgoing, Vendor's are not required to list the State as an additional insured for this type of policy.

**Commercial Crime and Third Party Fidelity Insurance** in an amount of: \_\_\_\_\_ per occurrence.

**Cyber Liability Insurance** in an amount of: \_\_\_\_\_ per occurrence.

**Builders Risk Insurance** in an amount equal to 100% of the amount of the Contract.

**Pollution Insurance** in an amount of: \_\_\_\_\_ per occurrence.

**Aircraft Liability** in an amount of: \_\_\_\_\_ per occurrence.

**\*\*\*STATE OF WV MUST BE LISTED AS ADDITIONAL INSURED ON INSURANCE CERTIFICATE**

**\*\*\*CERTIFICATE HOLDER SHOULD READ AS FOLLOWS:**  
STATE OF WV  
1900 KANAWHA BLVD E, BLDG 5, CHARLESTON, WV 25305

Notwithstanding anything contained in this section to the contrary, the Director of the Purchasing Division reserves the right to waive the requirement that the State be named as an additional insured on one or more of the Vendor's insurance policies if the Director finds that doing so is in the State's best interest.

**9. WORKERS' COMPENSATION INSURANCE:** The apparent successful Vendor shall comply with laws relating to workers compensation, shall maintain workers' compensation insurance when required, and shall furnish proof of workers' compensation insurance upon request.

**10. [Reserved]**

**11. LIQUIDATED DAMAGES:** This clause shall in no way be considered exclusive and shall not limit the State or Agency's right to pursue any other available remedy. Vendor shall pay liquidated damages in the amount specified below or as described in the specifications:

\_\_\_\_\_ for \_\_\_\_\_

Liquidated Damages Contained in the Specifications

**12. ACCEPTANCE:** Vendor's signature on its bid, or on the certification and signature page, constitutes an offer to the State that cannot be unilaterally withdrawn, signifies that the product or service proposed by vendor meets the mandatory requirements contained in the Solicitation for that product or service, unless otherwise indicated, and signifies acceptance of the terms and conditions contained in the Solicitation unless otherwise indicated.

**13. PRICING:** The pricing set forth herein is firm for the life of the Contract, unless specified elsewhere within this Solicitation/Contract by the State. A Vendor's inclusion of price adjustment provisions in its bid, without an express authorization from the State in the Solicitation to do so, may result in bid disqualification. Notwithstanding the foregoing, Vendor must extend any publicly advertised sale price to the State and invoice at the lower of the contract price or the publicly advertised sale price.

**14. PAYMENT IN ARREARS:** Payment in advance is prohibited under this Contract. Payment may only be made after the delivery and acceptance of goods or services. The Vendor shall submit invoices, in arrears.

**15. PAYMENT METHODS:** Vendor must accept payment by electronic funds transfer and P-Card. (The State of West Virginia's Purchasing Card program, administered under contract by a banking institution, processes payment for goods and services through state designated credit cards.)

**16. TAXES:** The Vendor shall pay any applicable sales, use, personal property or any other taxes arising out of this Contract and the transactions contemplated thereby. The State of West Virginia is exempt from federal and state taxes and will not pay or reimburse such taxes.

**17. ADDITIONAL FEES:** Vendor is not permitted to charge additional fees or assess additional charges that were not either expressly provided for in the solicitation published by the State of West Virginia or included in the unit price or lump sum bid amount that Vendor is required by the solicitation to provide. Including such fees or charges as notes to the solicitation may result in rejection of vendor's bid. Requesting such fees or charges be paid after the contract has been awarded may result in cancellation of the contract.

**18. FUNDING:** This Contract shall continue for the term stated herein, contingent upon funds being appropriated by the Legislature or otherwise being made available. In the event funds are not appropriated or otherwise made available, this Contract becomes void and of no effect beginning on July 1 of the fiscal year for which funding has not been appropriated or otherwise made available.

**19. CANCELLATION:** The Purchasing Division Director reserves the right to cancel this Contract immediately upon written notice to the vendor if the materials or workmanship supplied do not conform to the specifications contained in the Contract. The Purchasing Division Director may also cancel any purchase or Contract upon 30 days written notice to the Vendor in accordance with West Virginia Code of State Rules § 148-1-5.2.b.

**20. TIME:** Time is of the essence with regard to all matters of time and performance in this Contract.

**21. APPLICABLE LAW:** This Contract is governed by and interpreted under West Virginia law without giving effect to its choice of law principles. Any information provided in specification manuals, or any other source, verbal or written, which contradicts or violates the West Virginia Constitution, West Virginia Code or West Virginia Code of State Rules is void and of no effect.

**22. COMPLIANCE WITH LAWS:** Vendor shall comply with all applicable federal, state, and local laws, regulations and ordinances. By submitting a bid, Vendor acknowledges that it has reviewed, understands, and will comply with all applicable laws, regulations, and ordinances.

**SUBCONTRACTOR COMPLIANCE:** Vendor shall notify all subcontractors providing commodities or services related to this Contract that as subcontractors, they too are required to comply with all applicable laws, regulations, and ordinances. Notification under this provision must occur prior to the performance of any work under the contract by the subcontractor.

**23. ARBITRATION:** Any references made to arbitration contained in this Contract, Vendor's bid, or in any American Institute of Architects documents pertaining to this Contract are hereby deleted, void, and of no effect.

**24. MODIFICATIONS:** This writing is the parties' final expression of intent. Notwithstanding anything contained in this Contract to the contrary no modification of this Contract shall be binding without mutual written consent of the Agency, and the Vendor, with approval of the Purchasing Division and the Attorney General's office (Attorney General approval is as to form only). Any change to existing contracts that adds work or changes contract cost, and were not included in the original contract, must be approved by the Purchasing Division and the Attorney General's Office (as to form) prior to the implementation of the change or commencement of work affected by the change.

**25. WAIVER:** The failure of either party to insist upon a strict performance of any of the terms or provision of this Contract, or to exercise any option, right, or remedy herein contained, shall not be construed as a waiver or a relinquishment for the future of such term, provision, option, right, or remedy, but the same shall continue in full force and effect. Any waiver must be expressly stated in writing and signed by the waiving party.

**26. SUBSEQUENT FORMS:** The terms and conditions contained in this Contract shall supersede any and all subsequent terms and conditions which may appear on any form documents submitted by Vendor to the Agency or Purchasing Division such as price lists, order forms, invoices, sales agreements, or maintenance agreements, and includes internet websites or other electronic documents. Acceptance or use of Vendor's forms does not constitute acceptance of the terms and conditions contained thereon.

**27. ASSIGNMENT:** Neither this Contract nor any monies due, or to become due hereunder, may be assigned by the Vendor without the express written consent of the Agency, the Purchasing Division, the Attorney General's office (as to form only), and any other government agency or office that may be required to approve such assignments.

**28. WARRANTY:** The Vendor expressly warrants that the goods and/or services covered by this Contract will: (a) conform to the specifications, drawings, samples, or other description furnished or specified by the Agency; (b) be merchantable and fit for the purpose intended; and (c) be free from defect in material and workmanship.

**29. STATE EMPLOYEES:** State employees are not permitted to utilize this Contract for personal use and the Vendor is prohibited from permitting or facilitating the same.

**30. PRIVACY, SECURITY, AND CONFIDENTIALITY:** The Vendor agrees that it will not disclose to anyone, directly or indirectly, any such personally identifiable information or other confidential information gained from the Agency, unless the individual who is the subject of the information consents to the disclosure in writing or the disclosure is made pursuant to the Agency's policies, procedures, and rules. Vendor further agrees to comply with the Confidentiality Policies and Information Security Accountability Requirements, set forth in <http://www.state.wv.us/admin/purchase/privacy/default.html>.

**31. YOUR SUBMISSION IS A PUBLIC DOCUMENT:** Vendor's entire response to the Solicitation and the resulting Contract are public documents. As public documents, they will be disclosed to the public following the bid/proposal opening or award of the contract, as required by the competitive bidding laws of West Virginia Code §§ 5A-3-1 et seq., 5-22-1 et seq., and 5G-1-1 et seq. and the Freedom of Information Act West Virginia Code §§ 29B-1-1 et seq.

**DO NOT SUBMIT MATERIAL YOU CONSIDER TO BE CONFIDENTIAL, A TRADE SECRET, OR OTHERWISE NOT SUBJECT TO PUBLIC DISCLOSURE.**

Submission of any bid, proposal, or other document to the Purchasing Division constitutes your explicit consent to the subsequent public disclosure of the bid, proposal, or document. The Purchasing Division will disclose any document labeled "confidential," "proprietary," "trade secret," "private," or labeled with any other claim against public disclosure of the documents, to include any "trade secrets" as defined by West Virginia Code § 47-22-1 et seq. All submissions are subject to public disclosure without notice.

**32. LICENSING:** In accordance with West Virginia Code of State Rules § 148-1-6.1.e, Vendor must be licensed and in good standing in accordance with any and all state and local laws and requirements by any state or local agency of West Virginia, including, but not limited to, the West Virginia Secretary of State's Office, the West Virginia Tax Department, West Virginia Insurance Commission, or any other state agency or political subdivision. Obligations related to political subdivisions may include, but are not limited to, business licensing, business and occupation taxes, inspection compliance, permitting, etc. Upon request, the Vendor must provide all necessary releases to obtain information to enable the Purchasing Division Director or the Agency to verify that the Vendor is licensed and in good standing with the above entities.

**SUBCONTRACTOR COMPLIANCE:** Vendor shall notify all subcontractors providing commodities or services related to this Contract that as subcontractors, they too are required to be licensed, in good standing, and up-to-date on all state and local obligations as described in this section. Obligations related to political subdivisions may include, but are not limited to, business licensing, business and occupation taxes, inspection compliance, permitting, etc. Notification under this provision must occur prior to the performance of any work under the contract by the subcontractor.

**33. ANTITRUST:** In submitting a bid to, signing a contract with, or accepting a Award Document from any agency of the State of West Virginia, the Vendor agrees to convey, sell, assign, or transfer to the State of West Virginia all rights, title, and interest in and to all causes of action it may now or hereafter acquire under the antitrust laws of the United States and the State of West Virginia for price fixing and/or unreasonable restraints of trade relating to the particular commodities or services purchased or acquired by the State of West Virginia. Such assignment shall be made and become effective at the time the purchasing agency tenders the initial payment to Vendor.

**34. VENDOR CERTIFICATIONS:** By signing its bid or entering into this Contract, Vendor certifies (1) that its bid or offer was made without prior understanding, agreement, or connection with any corporation, firm, limited liability company, partnership, person or entity submitting a bid or offer for the same material, supplies, equipment or services; (2) that its bid or offer is in all respects fair and without collusion or fraud; (3) that this Contract is accepted or entered into without any prior understanding, agreement, or connection to any other entity that could be considered a violation of law; and (4) that it has reviewed this Solicitation in its entirety; understands the requirements, terms and conditions, and other information contained herein.

Vendor's signature on its bid or offer also affirms that neither it nor its representatives have any interest, nor shall acquire any interest, direct or indirect, which would compromise the performance of its services hereunder. Any such interests shall be promptly presented in detail to the Agency. The individual signing this bid or offer on behalf of Vendor certifies that he or she is authorized by the Vendor to execute this bid or offer or any documents related thereto on Vendor's behalf; that he or she is authorized to bind the Vendor in a contractual relationship; and that, to the best of his or her knowledge, the Vendor has properly registered with any State agency that may require registration.

**35. VENDOR RELATIONSHIP:** The relationship of the Vendor to the State shall be that of an independent contractor and no principal-agent relationship or employer-employee relationship is contemplated or created by this Contract. The Vendor as an independent contractor is solely liable for the acts and omissions of its employees and agents. Vendor shall be responsible for selecting, supervising, and compensating any and all individuals employed pursuant to the terms of this Solicitation and resulting contract. Neither the Vendor, nor any employees or subcontractors of the Vendor, shall be deemed to be employees of the State for any purpose whatsoever. Vendor shall be exclusively responsible for payment of employees and contractors for all wages and salaries, taxes, withholding payments, penalties, fees, fringe benefits, professional liability insurance premiums, contributions to insurance and pension, or other deferred compensation plans, including but not limited to, Workers' Compensation and Social Security obligations, licensing fees, etc. and the filing of all necessary documents, forms, and returns pertinent to all of the foregoing.

Vendor shall hold harmless the State, and shall provide the State and Agency with a defense against any and all claims including, but not limited to, the foregoing payments, withholdings, contributions, taxes, Social Security taxes, and employer income tax returns.

**36. INDEMNIFICATION:** The Vendor agrees to indemnify, defend, and hold harmless the State and the Agency, their officers, and employees from and against: (1) Any claims or losses for services rendered by any subcontractor, person, or firm performing or supplying services, materials, or supplies in connection with the performance of the Contract; (2) Any claims or losses resulting to any person or entity injured or damaged by the Vendor, its officers, employees, or subcontractors by the publication, translation, reproduction, delivery, performance, use, or disposition of any data used under the Contract in a manner not authorized by the Contract, or by Federal or State statutes or regulations; and (3) Any failure of the Vendor, its officers, employees, or subcontractors to observe State and Federal laws including, but not limited to, labor and wage and hour laws.

**37. PURCHASING AFFIDAVIT:** In accordance with West Virginia Code §§ 5A-3-10a and 5-22-1(i), the State is prohibited from awarding a contract to any bidder that owes a debt to the State or a political subdivision of the State, Vendors are required to sign, notarize, and submit the Purchasing Affidavit to the Purchasing Division affirming under oath that it is not in default on any monetary obligation owed to the state or a political subdivision of the state.

**38. ADDITIONAL AGENCY AND LOCAL GOVERNMENT USE:** This Contract may be utilized by other agencies, spending units, and political subdivisions of the State of West Virginia; county, municipal, and other local government bodies; and school districts (“Other Government Entities”), provided that both the Other Government Entity and the Vendor agree. Any extension of this Contract to the aforementioned Other Government Entities must be on the same prices, terms, and conditions as those offered and agreed to in this Contract, provided that such extension is in compliance with the applicable laws, rules, and ordinances of the Other Government Entity. A refusal to extend this Contract to the Other Government Entities shall not impact or influence the award of this Contract in any manner.

**39. CONFLICT OF INTEREST:** Vendor, its officers or members or employees, shall not presently have or acquire an interest, direct or indirect, which would conflict with or compromise the performance of its obligations hereunder. Vendor shall periodically inquire of its officers, members and employees to ensure that a conflict of interest does not arise. Any conflict of interest discovered shall be promptly presented in detail to the Agency.

**40. REPORTS:** Vendor shall provide the Agency and/or the Purchasing Division with the following reports identified by a checked box below:

Such reports as the Agency and/or the Purchasing Division may request. Requested reports may include, but are not limited to, quantities purchased, agencies utilizing the contract, total contract expenditures by agency, etc.

Quarterly reports detailing the total quantity of purchases in units and dollars, along with a listing of purchases by agency. Quarterly reports should be delivered to the Purchasing Division via email at [purchasing.requisitions@wv.gov](mailto:purchasing.requisitions@wv.gov).

**41. BACKGROUND CHECK:** In accordance with W. Va. Code § 15-2D-3, the Director of the Division of Protective Services shall require any service provider whose employees are regularly employed on the grounds or in the buildings of the Capitol complex or who have access to sensitive or critical information to submit to a fingerprint-based state and federal background inquiry through the state repository. The service provider is responsible for any costs associated with the fingerprint-based state and federal background inquiry.

After the contract for such services has been approved, but before any such employees are permitted to be on the grounds or in the buildings of the Capitol complex or have access to sensitive or critical information, the service provider shall submit a list of all persons who will be physically present and working at the Capitol complex to the Director of the Division of Protective Services for purposes of verifying compliance with this provision. The State reserves the right to prohibit a service provider’s employees from accessing sensitive or critical information or to be present at the Capitol complex based upon results addressed from a criminal background check.

Revised 01/09/2020

Service providers should contact the West Virginia Division of Protective Services by phone at (304) 558-9911 for more information.

**42. PREFERENCE FOR USE OF DOMESTIC STEEL PRODUCTS:** Except when authorized by the Director of the Purchasing Division pursuant to W. Va. Code § 5A-3-56, no contractor may use or supply steel products for a State Contract Project other than those steel products made in the United States. A contractor who uses steel products in violation of this section may be subject to civil penalties pursuant to W. Va. Code § 5A-3-56. As used in this section:

- a. "State Contract Project" means any erection or construction of, or any addition to, alteration of or other improvement to any building or structure, including, but not limited to, roads or highways, or the installation of any heating or cooling or ventilating plants or other equipment, or the supply of and materials for such projects, pursuant to a contract with the State of West Virginia for which bids were solicited on or after June 6, 2001.
- b. "Steel Products" means products rolled, formed, shaped, drawn, extruded, forged, cast, fabricated or otherwise similarly processed, or processed by a combination of two or more or such operations, from steel made by the open heath, basic oxygen, electric furnace, Bessemer or other steel making process. The Purchasing Division Director may, in writing, authorize the use of foreign steel products if:
- c. The cost for each contract item used does not exceed one tenth of one percent (.1%) of the total contract cost or two thousand five hundred dollars (\$2,500.00), whichever is greater. For the purposes of this section, the cost is the value of the steel product as delivered to the project; or
- d. The Director of the Purchasing Division determines that specified steel materials are not produced in the United States in sufficient quantity or otherwise are not reasonably available to meet contract requirements.

**43. PREFERENCE FOR USE OF DOMESTIC ALUMINUM, GLASS, AND STEEL:** In Accordance with W. Va. Code § 5-19-1 et seq., and W. Va. CSR § 148-10-1 et seq., for every contract or subcontract, subject to the limitations contained herein, for the construction, reconstruction, alteration, repair, improvement or maintenance of public works or for the purchase of any item of machinery or equipment to be used at sites of public works, only domestic aluminum, glass or steel products shall be supplied unless the spending officer determines, in writing, after the receipt of offers or bids, (1) that the cost of domestic aluminum, glass or steel products is unreasonable or inconsistent with the public interest of the State of West Virginia, (2) that domestic aluminum, glass or steel products are not produced in sufficient quantities to meet the contract requirements, or (3) the available domestic aluminum, glass, or steel do not meet the contract specifications. This provision only applies to public works contracts awarded in an amount more than fifty thousand dollars (\$50,000) or public works contracts that require more than ten thousand pounds of steel products.

The cost of domestic aluminum, glass, or steel products may be unreasonable if the cost is more than twenty percent (20%) of the bid or offered price for foreign made aluminum, glass, or steel products. If the domestic aluminum, glass or steel products to be supplied or produced in a



“substantial labor surplus area”, as defined by the United States Department of Labor, the cost of domestic aluminum, glass, or steel products may be unreasonable if the cost is more than thirty percent (30%) of the bid or offered price for foreign made aluminum, glass, or steel products. This preference shall be applied to an item of machinery or equipment, as indicated above, when the item is a single unit of equipment or machinery manufactured primarily of aluminum, glass or steel, is part of a public works contract and has the sole purpose or of being a permanent part of a single public works project. This provision does not apply to equipment or machinery purchased by a spending unit for use by that spending unit and not as part of a single public works project.

All bids and offers including domestic aluminum, glass or steel products that exceed bid or offer prices including foreign aluminum, glass or steel products after application of the preferences provided in this provision may be reduced to a price equal to or lower than the lowest bid or offer price for foreign aluminum, glass or steel products plus the applicable preference. If the reduced bid or offer prices are made in writing and supersede the prior bid or offer prices, all bids or offers, including the reduced bid or offer prices, will be reevaluated in accordance with this rule.

**44. INTERESTED PARTY SUPPLEMENTAL DISCLOSURE:** W. Va. Code § 6D-1-2 requires that for contracts with an actual or estimated value of at least \$1 million, the vendor must submit to the Agency a supplemental disclosure of interested parties reflecting any new or differing interested parties to the contract, which were not included in the original pre-award interested party disclosure, within 30 days following the completion or termination of the contract. A copy of that form is included with this solicitation or can be obtained from the WV Ethics Commission. This requirement does not apply to publicly traded companies listed on a national or international stock exchange. A more detailed definition of interested parties can be obtained from the form referenced above.

**45. PROHIBITION AGAINST USED OR REFURBISHED:** Unless expressly permitted in the solicitation published by the State, Vendor must provide new, unused commodities, and is prohibited from supplying used or refurbished commodities, in fulfilling its responsibilities under this Contract.

**DESIGNATED CONTACT:** Vendor appoints the individual identified in this Section as the Contract Administrator and the initial point of contact for matters relating to this Contract.

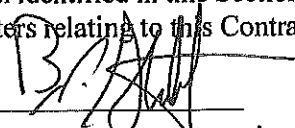
BRIAN P. STRUBLE VP ; GM   
(Name, Title)  
BRIAN P. STRUBLE, VP ; GM EASTERN VAULT CO., INC.  
(Printed Name and Title)  
PO BOX 1134 PRINCETON WV 24740  
(Address)  
304-425-8955 / 304-425-1171  
(Phone Number) / (Fax Number)  
BSTRUBLE @ EASTERNVAULT. NET  
(email address)

**CERTIFICATION AND SIGNATURE:** By signing below, or submitting documentation through wvOASIS, I certify that I have reviewed this Solicitation in its entirety; that I understand the requirements, terms and conditions, and other information contained herein; that this bid, offer or proposal constitutes an offer to the State that cannot be unilaterally withdrawn; that the product or service proposed meets the mandatory requirements contained in the Solicitation for that product or service, unless otherwise stated herein; that the Vendor accepts the terms and conditions contained in the Solicitation, unless otherwise stated herein; that I am submitting this bid, offer or proposal for review and consideration; that I am authorized by the vendor to execute and submit this bid, offer, or proposal, or any documents related thereto on vendor's behalf; that I am authorized to bind the vendor in a contractual relationship; and that to the best of my knowledge, the vendor has properly registered with any State agency that may require registration.

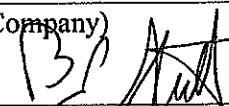
EASTERN VAULT CO., INC.  
(Company)  
 BRIAN P. STRUBLE VP ; GM  
(Authorized Signature) (Representative Name, Title)  
BRIAN P. STRUBLE VP ; GM  
(Printed Name and Title of Authorized Representative)  
4-27-2020  
(Date)  
304-425-8955 / 304-425-1171  
(Phone Number) (Fax Number)

ADDENDUM ACKNOWLEDGEMENT FORM  
SOLICITATION NO.: CRFQ DOT2000000152

Instructions: Please acknowledge receipt of all addenda issued with this solicitation by completing this addendum acknowledgment form. Check the box next to each addendum received and sign below. Failure to acknowledge addenda may result in bid disqualification.

Acknowledgment: I hereby acknowledge receipt of the following addenda and have made the necessary revisions to my proposal, plans and/or specification, etc.

Addendum Numbers Received:  
(Check the box next to each addendum received)

- |   |  |
|---|--|
| <input type="checkbox"/> Addendum No. 1 | <input type="checkbox"/> Addendum No. 6  |
| <input type="checkbox"/> Addendum No. 2 | <input type="checkbox"/> Addendum No. 7  |
| <input type="checkbox"/> Addendum No. 3 | <input type="checkbox"/> Addendum No. 8  |
| <input type="checkbox"/> Addendum No. 4 | <input type="checkbox"/> Addendum No. 9  |
| <input type="checkbox"/> Addendum No. 5 | <input type="checkbox"/> Addendum No. 10 |

I understand that failure to confirm the receipt of addenda may be cause for rejection of this bid. I further understand that any verbal representation made or assumed to be made during any oral discussion held between Vendor's representatives and any state personnel is not binding. Only the information issued in writing and added to the specifications by an official addendum is binding.

EASTERN VAULT CO., INC.

Company

Authorized Signature

Date

NOTE: This addendum acknowledgment should be submitted with the bid to expedite document processing.

**REQUEST FOR QUOTATION**  
**CRFQ DOT2000000152**  
**Concrete Box Beams, Bridge Rail, and Components (07200898)**

---

**SPECIFICATIONS**

**1. PURPOSE AND SCOPE:** The West Virginia Purchasing Division is soliciting bids on behalf of the West Virginia Division of Highways to establish a contract for the one-time purchase of Concrete Box Beams, Bridge Rail, and Components for Hope Station Superstructure Replacement.

**1. DEFINITIONS:** The terms listed below shall have the meanings assigned to them below. Additional definitions can be found in section 2 of the General Terms and Conditions.

**2.1 “Contract Item”** means Concrete Box Beams, Bridge Rail, and Components as more fully described by these specifications.

**2.2 “Pricing Page”** means the pages, contained in wvOASIS or attached as Exhibit A, upon which Vendor should list its proposed price for the Contract Items.

**2.3 “Solicitation”** means the official notice of an opportunity to supply the State with goods or services that is published by the Purchasing Division.

**3. GENERAL REQUIREMENTS:**

**3.1 Mandatory Contract Item Requirements:** Contract Item must meet or exceed the mandatory requirements listed below.

**3.1.1 27-inch Interior Box Beam (1,361 Square Feet)**

**3.1.1.1** Box beam must be 6 pieces – 3 feet 0 inches X 75 feet 7 inches.

**3.1.1.2** Box beam must have a minimum strength of 5500 psi at detention and 8000 psi at 28 days. Pre-stressing strands must be seven-wire uncoated low relaxation oversize strand (AS = 0.167 square inches), with a minimum tensile strength of 270,000 psi.

**3.1.1.3** Box beam lab reports must accompany the shipping ticket.

**3.1.2 27-Inch Exterior Box Beam (454 Square Feet)**

**3.1.2.1** Box beam must be 2 pieces – 3 feet 0 inches X 75 feet 7 inches.

**REQUEST FOR QUOTATION**  
**CRFQ DOT2000000152**  
**Concrete Box Beams, Bridge Rail, and Components (07200898)**

---

- 3.1.2.2 Box beam must have a minimum strength of 5500 psi at detention and 8000 psi at 28 days. Pre-stressing strands must be seven-wire uncoated low relaxation oversize strand (AS = 0.167 square inches), with a minimum tensile strength of 270,000 psi.
- 3.1.2.3 Box beam lab reports must accompany the shipping ticket.
- 3.1.3 Elastomeric Laminated Bearing Pads (B-1) (14 Each)**
- 3.1.3.1 Pads must be 1-13/16 inches X 4-3/4 inches X 28 inches.
- 3.1.4 Elastomeric Laminated Bearing Pads (B-2) (4 Each)**
- 3.1.4.1 Pads must be 1-13/16 inches X 4-3/4 inches X 15-1/2 inches.
- 3.1.5 Swedged Anchor Bolt or #8 Deformed Rebar (16 Each)**
- 3.1.5.1 Bolt or rebar must be 1-inch X 2 feet 0 inches.
- 3.1.6 Sponge Rubber Preformed Joint Filler (2 Each)**
- 3.1.6.1 Joint filler must be 1 inches thick.
- 3.1.6.2 Joint filler must be 24 feet 5 ¼ inches X 2 feet 4 inches.
- 3.1.7 Sponge Rubber Preformed Joint Filler (4 Each)**
- 3.1.7.1 Joint filler must be 2 inches thick.
- 3.1.7.2 Joint filler must be 4-3/4 inches X 6-7/8 inches.
- 3.1.8 Sponge Rubber Preformed Joint Filler (12 Each)**
- 3.1.8.1 Joint filler must be 2 inches thick.
- 3.1.8.2 Joint filler must be 4-3/4 inches X 8-3/4 inches.
- 3.1.9 Sponge Rubber Preformed Joint Filler (16 Each)**

**REQUEST FOR QUOTATION**  
**CRFQ DOT2000000152**  
**Concrete Box Beams, Bridge Rail, and Components (07200898)**

---

3.1.9.1 Joint filler must be 2 inches thick.

3.1.9.2 Joint filler must be 6-5/8 inches X 3 feet 0-7/8 inches.

**3.1.10 Sponge Rubber Washer (49 Each)**

3.1.10.1 Washer must have 3-1/2-inch holes.

3.1.10.2 Washer must be 8 inches X 8 inches X 1 inch thick.

**3.1.11 Bridge Rail (137.5 Linear Feet)**

3.1.11.1 Bridge rail must conform to the standards set for in section 607 of the West Virginia Division of Highways Standard Specifications of Roads and Bridges (adopted 2017).

3.1.11.2 Bridge rail must include inserts, hardware, posts, and guardrail (see plans for detail).

3.1.11.3 Bridge rail (24 bridge guardrail posts with hardware, and 137.5 linear feet of guardrail) must be attached to beams by fabricator.

*Note: Shipping constraints may limit the length of attached guardrail.*

**3.1.12 Post-Tension Bearing Plates (14 Each)**

3.1.12.1 Bearing plate must be 9 inches X 9 inches X 1 inch thick.

**3.1.13 Post-Tension Bar (192 Linear Feet)**

3.1.13.1 Post tension bar must be 1-inch diameter

3.1.13.2 Post tension bar must be 7 pieces – 27 feet 5-1/4 inches long.

3.1.13.3 Post tension bar must come with nuts.

**3.1.14 Asymmetrical Thrie-Beam Transition Section (4 Each)**

**REQUEST FOR QUOTATION**  
**CRFQ DOT2000000152**  
**Concrete Box Beams, Bridge Rail, and Components (07200898)**

---

3.1.14.1 Transition sections must be 6 feet 3 inches.

3.1.14.2 Transition sections must be supplied but NOT attached.

3.1.15 *Materials supplied under this contract shall meet the applicable requirements of the West Virginia Dept. of Transportation, Division of Highways Standard Specification Roads and Bridges, Adopted 2017, and the current Supplemental Specifications. Specifications are available on the following website:*

[www.transportation.wv.gov/highways/engineering/pages/publications.aspx](http://www.transportation.wv.gov/highways/engineering/pages/publications.aspx)

**4. CONTRACT AWARD:**

**4.1 Contract Award:** The Contract is intended to provide Agencies with a purchase price for the Contract Items. The Contract shall be awarded to the Vendor that provides the Contract Items meeting the required specifications for the lowest overall total cost as shown on the Pricing Pages.

**4.2 Pricing Page:** Vendor should complete the Pricing Page by inputting the Unit Price for each Item Number and multiply the Quantities to calculate the Total Cost for each. The Total Cost for each Item number will be added together to calculate the Total Bid Amount. Vendor should complete the Pricing Page in full as failure to complete the Pricing Page in its entirety may result in Vendor's bid being disqualified.

Vendor should type or electronically enter the information into the Pricing Page to prevent errors in the evaluation.

Notwithstanding the foregoing, the Purchasing Division may correct errors it deems appropriate. Vendor should type or electronically enter the information into the Pricing Page to prevent errors in the evaluation.

**5. PAYMENT:**

**5.1 Payment:** Vendor shall accept payment in accordance with the payment procedures of the State of West Virginia.

**REQUEST FOR QUOTATION**  
**CRFQ DOT2000000152**  
**Concrete Box Beams, Bridge Rail, and Components (07200898)**

---

**6. DELIVERY AND RETURN:**

**6.1 Shipment and Delivery:** Vendor shall ship the Contract Items immediately after being awarded this Contract and receiving a purchase order or notice to proceed. Vendor shall deliver the Contract Items within **30** working days after receiving a purchase order or notice to proceed. Contract Items must be delivered to the Agency at the bridge site in Lewis County as shown on sheet 1 of the plans.

**6.2 Late Delivery:** The Agency placing the order under this Contract must be notified in writing if the shipment of the Contract Items will be delayed for any reason. Any delay in delivery that could cause harm to an Agency will be grounds for cancellation of the Contract, and/or obtaining the Contract Items from a third party.

Any agency seeking to obtain the Contract Items from a third party under this provision must first obtain approval of the Purchasing Division.

**6.3 Delivery Payment / Risk of Loss:** Vendor shall deliver the Contract Items F.O.B. destination to the Agency's location.

**6.4 Return of Unacceptable Items:** If the Agency deems the Contract Items to be unacceptable, the Contract Items shall be returned to Vendor at Vendor's expense and with no restocking charge. Vendor shall either make arrangements for the return within five (5) days of being notified that items are unacceptable or permit the Agency to arrange for the return and reimburse Agency for delivery expenses. If the original packaging cannot be utilized for the return, Vendor will supply the Agency with appropriate return packaging upon request. All returns of unacceptable items shall be F.O.B. the Agency's location. The returned product shall either be replaced, or the Agency shall receive full credit or refund for the purchase price, at the Agency's discretion.

**6.5 Return Due to Agency Error:** Items ordered in error by the Agency will be returned for credit within 30 days of receipt, F.O.B. Vendor's location. Vendor shall not charge a restocking fee if returned products are in a resalable condition. Items shall be deemed to be in a resalable condition if they are unused and in the original packaging. Any restocking fee for items not in a resalable condition shall be the lower of the Vendor's customary restocking fee or 5% of the total invoiced value of the returned items.



**REQUEST FOR QUOTATION**  
**CRFQ DOT2000000152**  
**Concrete Box Beams, Bridge Rail, and Components (07200898)**

---

**7 VENDOR DEFAULT:**

**7.1** The following shall be considered a vendor default under this Contract.

- 7.1.1** Failure to provide Contract Items in accordance with the requirements contained herein.
- 7.1.2** Failure to comply with other specifications and requirements contained herein.
- 7.1.3** Failure to comply with any laws, rules, and ordinances applicable to the Contract Services provided under this Contract.
- 7.1.4** Failure to remedy deficient performance upon request.

**7.2** The following remedies shall be available to Agency upon default.

- 7.2.1** Immediate cancellation of the Contract.
- 7.2.2** Immediate cancellation of one or more release orders issued under this Contract.
- 7.2.3** Any other remedies available in law or equity.





Public Roads Dist.	State Dist. No.	State Project No.	Federal Project No.	Fiscal Year	County	Sheet No.	Total Sheets
W.V.	7	S321-33/22-0.01	N/A	2020	LEWIS	3	16

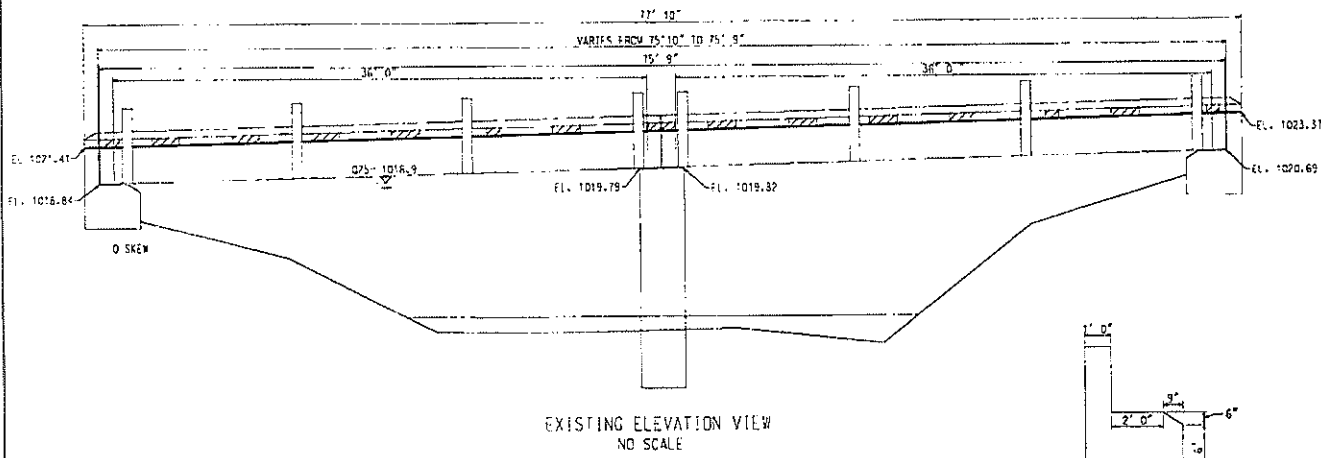

ESTIMATE OF QUANTITIES			
PROJECT NO. S321-33/22-0.01			
FOR INFORMATION ONLY			
DESCRIPTION	UNITS	NO. AND SIZE	TOTAL
27 IN. CONC. BOX BEAMS (EXT.)	SF	2 @ 15' 1" LONG	454
27 IN. CONC. BOX BEAMS (INT.)	SF	6 @ 15' 1" LONG	1361
1" POST TENSIONING BAR X 27'5 1/2" W/ MUTS	LF	7 EA.	192
9" X 9" X 1" PLATES	EA	-	14
BEARING PADS 14 1/2" X 4 1/2" X 28" (B1)	EA	-	14
BEARING PADS 14 1/2" X 4 1/2" X 15 1/2" (B2)	EA	-	4
2" SPONGE RUBBER PREFORMED JOINT FILLER	EA	6 1/2" X 3' 0 1/2"	16
2" SPONGE RUBBER PREFORMED JOINT FILLER	EA	4 1/2" X 8 1/2"	12
2" SPONGE RUBBER PREFORMED JOINT FILLER	EA	4 1/2" X 5 1/2"	4
1" SPONGE RUBBER PREFORMED JOINT FILLER	EA	24' 5 1/2" X 2' 4"	2
1" SPONGE RUBBER WASHER	EA	8" X 8" W/ 3/16" DIA. HOLE	49
WEDGED ANCHOR BOLTS	EA	1" DIA. X 2' 0"	16
NON-SHRINK GROUT FOR JOINTS AND ANCHORS	BAG	-	251
GUARDRAIL INSERT AND HARDWARE	EA	-	24
BRIDGE GUARDRAIL (THREE BEAM)	LF	-	137.5
ASYMMETRICAL THREE BEAM TRANSITION	EA	-	4
CLASS 1 APPROX. GUARDRAIL	LF	-	137.5
N.A.A. WEARING	TON	-	41
AGGREGATE BASE STONE	TON	-	380
ANTI-ROCK WATERPROOFING MEMBRANE	ROLL	-	20
ELASTICAL PRIMER	EA	-	3
SILT FENCE	LF	-	200

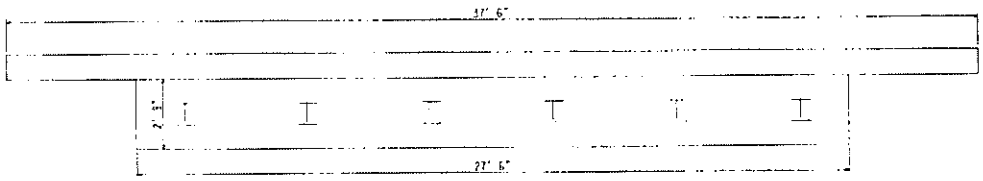
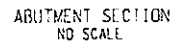
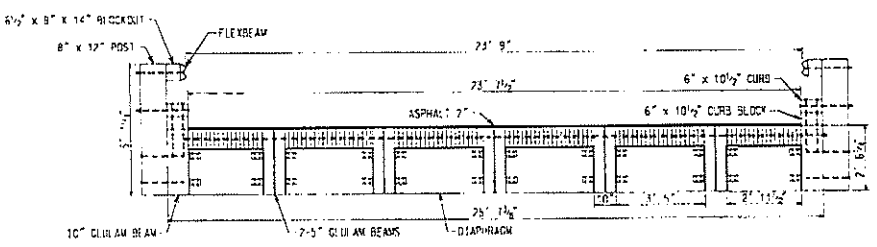

SCOPE OF WORK

1. INSTALL TRAFFIC CONTROL. REMOVE NECESSARY GUARDRAIL. INSTALL END TREATMENTS WHEREVER NECESSARY.
2. INSTALL SEDIMENT AND EROSION CONTROL PROTECTION.
3. CLEAR AND GRUB IF NECESSARY.
4. EXCAVATE UNSUITABLE MATERIAL FOR TEMPORARY BRIDGE.
5. CONSTRUCT TEMPORARY DETOUR AND SWITCH TRAFFIC OVER TO TEMPORARY BRIDGE.
6. DEMO. EXISTING BRIDGE'S SUPERSTRUCTURE.
7. CONSTRUCT NEW SUPERSTRUCTURE WITH 8-136" X 27" CONCRETE BOX BEAMS.
8. GROUT AND POST TENSION NEW BEAMS.
9. PLACE ANTI-ROCK MEMBRANE. THEN PAVE NEW STRUCTURE. TIE INTO EXISTING PAVEMENT.
10. DECONSTRUCT TEMPORARY DETOUR. REPLACE ANY AND ALL GUARDRAIL BACK TO EXISTING.

DESIGNED BY:	CHD	12-19				
DRAWN BY:	CHD	12-19				
CHECKED BY:	RHM					
REVIEWED BY:	CHD	RESCD	JMSK	REVISION	DATE	BY

THE WEST VIRGINIA DEPARTMENT OF TRANSPORTATION  
DIVISION OF HIGHWAYS  
EXISTING ELEVATION &  
DECK SECTION

Project Name	State	State	Federal	Fiscal	County	Sheet	Total
Div.	Dist.	Project	Project	Year		No.	Sheets
W.V.	7	SS21	N/A	2020	LEWIS	4	16
		0.01					



**EROSION AND SEDIMENT CONTROL PLAN NOTE**

EROSION AND SEDIMENT CONTROL MEASURES SHALL BE PROVIDED IN ACCORDANCE WITH THE WORK SPECIFICATIONS AND EROSION CONTROL PLAN WITH APPROVED EROSION CONTROL MEASURES. IT SHALL BE THE RESPONSIBILITY OF THE CONTRACTOR TO VERIFY THAT ALL EROSION AND SEDIMENT CONTROL MEASURES ARE IN PLACE AND MAINTAINED THROUGHOUT THE CONSTRUCTION PERIOD. TO ONLY BE WHAT IS NECESSARY TO ESTABLISH THESE OPERATIONS.

**RT-33/22 (R.S.) CURVE DATA**

PI- STATION 02+41.4	CC- 8000.00
NORTHING 10711.7314	8000.0000
EASTING 18711.8444	19848.4885
ELEVATION 1009.36	
PC- STATION 08+47.33	PI- 14+17.33
NORTHING 10071.0208	10141.4178
EASTING 18711.8444	18711.8444
ELEVATION 1009.36	1071.52
DEFLECTION 27° 19' 41.62" B	
RADIUS 512.10	
LENGTH 152.10	
TANGENT 152.10	
LOW CHORD 314.26	
ELEVATION CHORD 1145.27	
DEC. OF CURVE 42° 29' 08.27"	

**RT-33 (R.S.) CURVE DATA**

PI- STATION 12+01.56	CC- 8000.00
NORTHING 10711.7314	8000.0000
EASTING 18711.8444	19848.4885
ELEVATION 1009.36	
PC- STATION 18+13.56	PI- 23+43.56
NORTHING 10071.0208	10211.7177
EASTING 18711.8444	18711.8444
ELEVATION 1009.36	1981.2567
DEFLECTION 27° 19' 41.62" B	
RADIUS 512.10	
LENGTH 152.10	
TANGENT 152.10	
LOW CHORD 314.26	
ELEVATION CHORD 1145.27	
DEC. OF CURVE 42° 29' 08.27"	

NOTE: PROJECT PLAN VIEW WAS OBTAINED FROM AERIAL PHOTOGRAPHS. NO SURVEY WAS PERFORMED. ALL DIMENSIONS ARE APPROXIMATE.

DESIGNED BY:	CMH	12-10					
DRAWN BY:	CMH	12-10					
CHECKED BY:	RMH						
REVIEWED BY:	CMH						

THE WEST VIRGINIA DEPARTMENT OF TRANSPORTATION  
DIVISION OF HIGHWAYS  
PROJECT PLAN VIEW

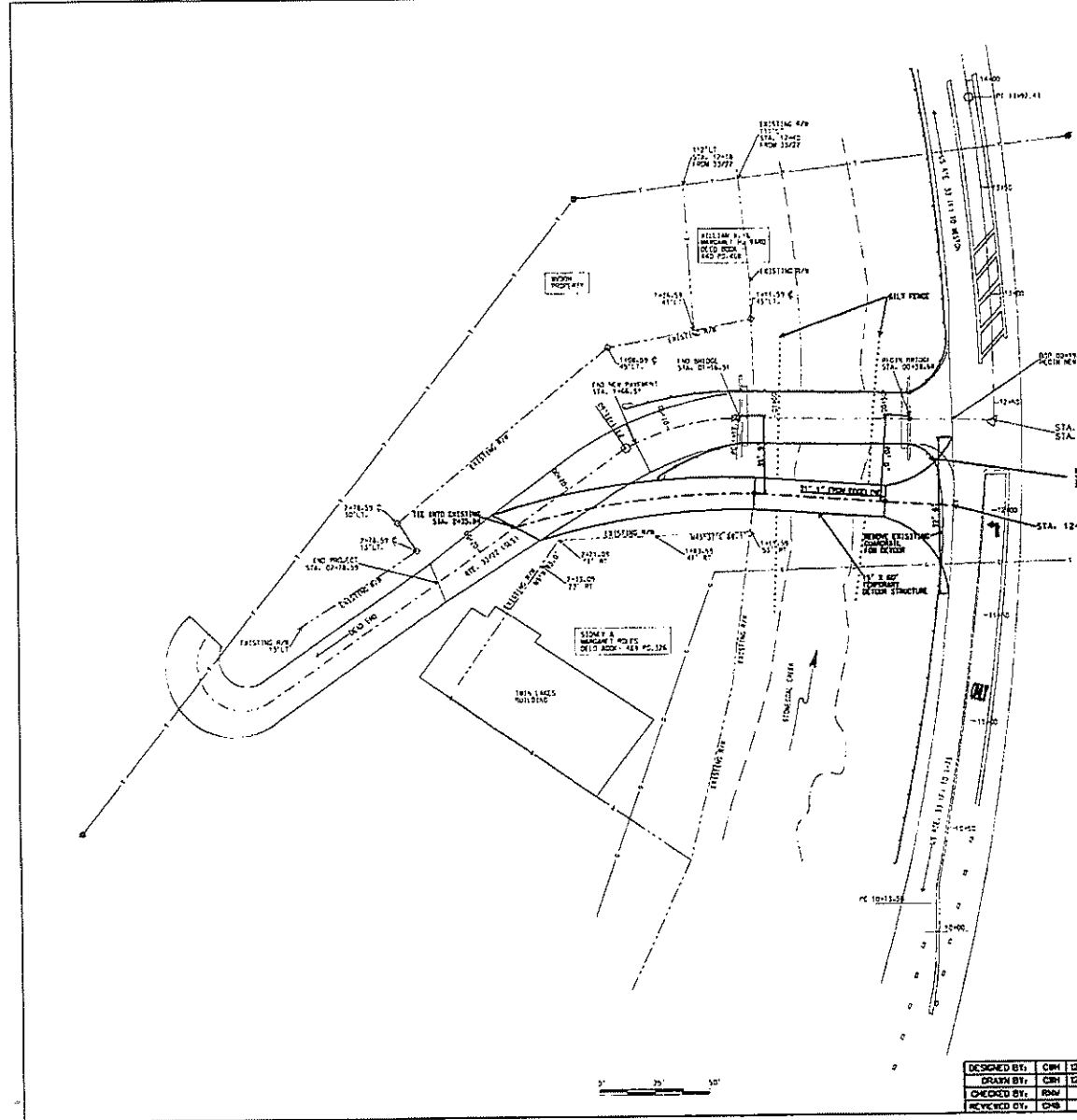

Public Road Dist.	State No.	State Project No.	Federal Project No.	Fiscal Year	County	Sheet No.	Total Sheets
W. V.	7	S321 33/22 0.01	N/A	2020	LEWIS	5	16

**MAINTENANCE OF TRAFFIC NOTES**

- A. MAINTENANCE OF TRAFFIC SHALL BE IN ACCORDANCE WITH SECTION 636 OF THE WEST VIRGINIA DEPARTMENT OF TRANSPORTATION, DIVISION OF HIGHWAYS, STANDARD SPECIFICATIONS, ROADS AND BRIDGES, ADOPTED 2017. THE CONTRACT DOCUMENTS AND THE CONTRACT PLANS ARE THE CONTROLLING PROVISIONS APPLICABLE TO THIS PROJECT, AND THE MANUAL - TRAFFIC CONTROL FOR STREET AND HIGHWAY CONSTRUCTION AND MAINTENANCE OPERATIONS, MAY 2006 WHICH IS MADE A PART OF THIS CONTRACT AND THE TRAFFIC PLAN FOR INDIVIDUAL SEGMENTS AS DESCRIBED BELOW:
- B. REFLECTIVE SHEETING ON TEMPORARY TRAFFIC CONTROL DEVICES SHALL BE OF NEW CONDITION AT BEGINNING OF THE PROJECT LIFE. NIGHT VISIBILITY AND LEGIBILITY SHALL BE MAINTAINED.
- C. ACCESS TO ALL HOUSES AND BUSINESSES SHALL BE MAINTAINED AT ALL TIMES.
- D. LOCATIONS OF ALL TRAFFIC CONTROL DEVICES SHOWN ON THE MAINTENANCE OF TRAFFIC PLAN ARE APPROXIMATE. FINAL LOCATION OF THE TRAFFIC CONTROL DEVICES ARE TO BE ESTABLISHED BY THE ENGINEER IN THE FIELD.
- E. FLAGGER SHALL BE USED AS DIRECTED BY ENGINEER. COSTS SHALL BE INCLUDED IN BID ITEM 636014-001.
- F. EXISTING SIGNS AND DELINEATORS: ANY SUCH EXISTING FACILITIES RELOCATED, REMOVED, OR DAMAGED BY THE CONTRACTOR SHALL BE REPLACED TO ITS ORIGINAL CONDITION BY THE CONTRACTOR AT HIS EXPENSE. COST SHALL BE INCIDENTAL TO ITEM 636011-001.
- G. DURING EACH STAGE OF CONSTRUCTION, THE CONTRACTOR SHALL COVER ALL SIGNS WHICH ARE NOT APPROPRIATE TO THE CONTRACTOR'S TRAFFIC RESTRICTIONS:
  1. WHEN COVERING EXISTING SIGNS THE CONTRACTOR HAS THE OPTION OF USING:
    - a. HEAVY DUTY BLACK OVERLAY (PLASTIC OR DUPLEX TYPE)
    - b. THIN WOOD OVERLAY (E.G. PLUMWOOD)
    - c. TAKING SIGNS DOWN AND REINSTALLING WHEN APPROPRIATE
 ANY DAMAGES SHALL REQUIRE REPLACEMENT TO ORIGINAL CONDITION AT CONTRACTOR'S EXPENSE. COSTS SHALL BE INCIDENTAL TO BID ITEM 636011-001.
- H. CONTRACTOR WILL ONLY BE PAID FOR SETUP OF TRAFFIC CONTROL DEVICES ONE TIME.
- I. THE CONTRACTOR SHALL MAINTAIN WORKING STORM DRAINAGE SYSTEMS THROUGH THE WORK AREAS AT ALL TIMES DURING CONSTRUCTION.
- J. TRAFFIC CONTROL DEVICES SHOWN ON THE MAINTENANCE OF TRAFFIC PLANS ARE NOT DRAWN TO SCALE.
- K. FLAGGER: WHEN WORK IS PERFORMED AT NIGHT WITH A FLAGGER, THE FLAGGER STATIONS SHALL BE ADEQUATELY ILLUMINATED. THIS COST SHALL BE PAID FOR AS PART OF ITEM 636014-001.

- PHASE 1:** ERECT TRAFFIC CONTROL DEVICES IN ACCORDANCE WITH THE TEMPORARY TRAFFIC CONTROL PLAN WHILE MAINTAINING TWO-WAY TRAFFIC ON EXISTING ROADS. TRAFFIC CONTROL DEVICES SHALL BE ADDED IF DEEMED NECESSARY TO KEEP PUBLIC SAFE.
- PHASE 2:** CONSTRUCT THE TEMPORARY DETOUR ROUTE FROM STA. 2+35.84 TO US 331F1, AND SHIFT TRAFFIC TO DETOUR ROUTE.
- PHASE 3:** CONSTRUCT NEW SUPERSTRUCTURE ON C.R. 33/22.
- PHASE 4:** SHIFT TRAFFIC TO BACK TO THE EXISTING BRIDGE AND ROADWAY. REMOVE DETOUR ROUTE AND TRAFFIC CONTROL AFTER GUARDRAIL SYSTEMS ARE FULLY REINSTALLED.

- SIGN OF PORTABLE OR PERMANENT SUPPORT
- ⊗ TYPE "B" WARNING LIGHTS
- DRUM
- ▬ TYPE III BARRICADES
- W/ TYPE "B" LIGHTS
- WORK AREA

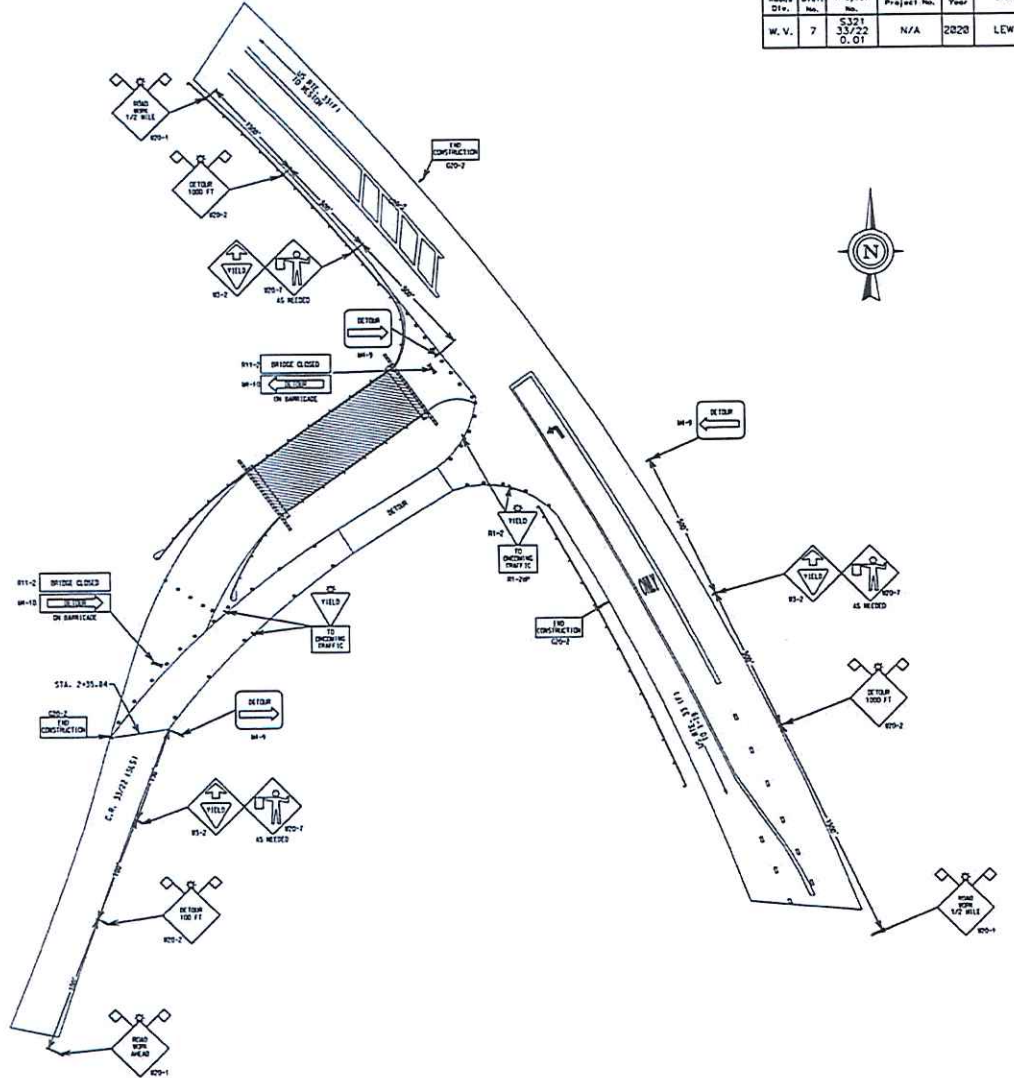

DESIGNED BY:	DATE:	REVISION:	DATE:	BY:
CMH	12-19			
CMH	12-19			
HPW				
CMH				

THE WEST VIRGINIA DEPARTMENT OF TRANSPORTATION  
DIVISION OF HIGHWAYS  
TRAFFIC CONTROL PLAN

Route No.	Sheet No.	State Project No.	Federal Project No.	Fiscal Year	County	Sheet No.	Total Sheets
W.V. 7	7	6321 33/22 G.01	N/A	2020	LEWIS	6	16

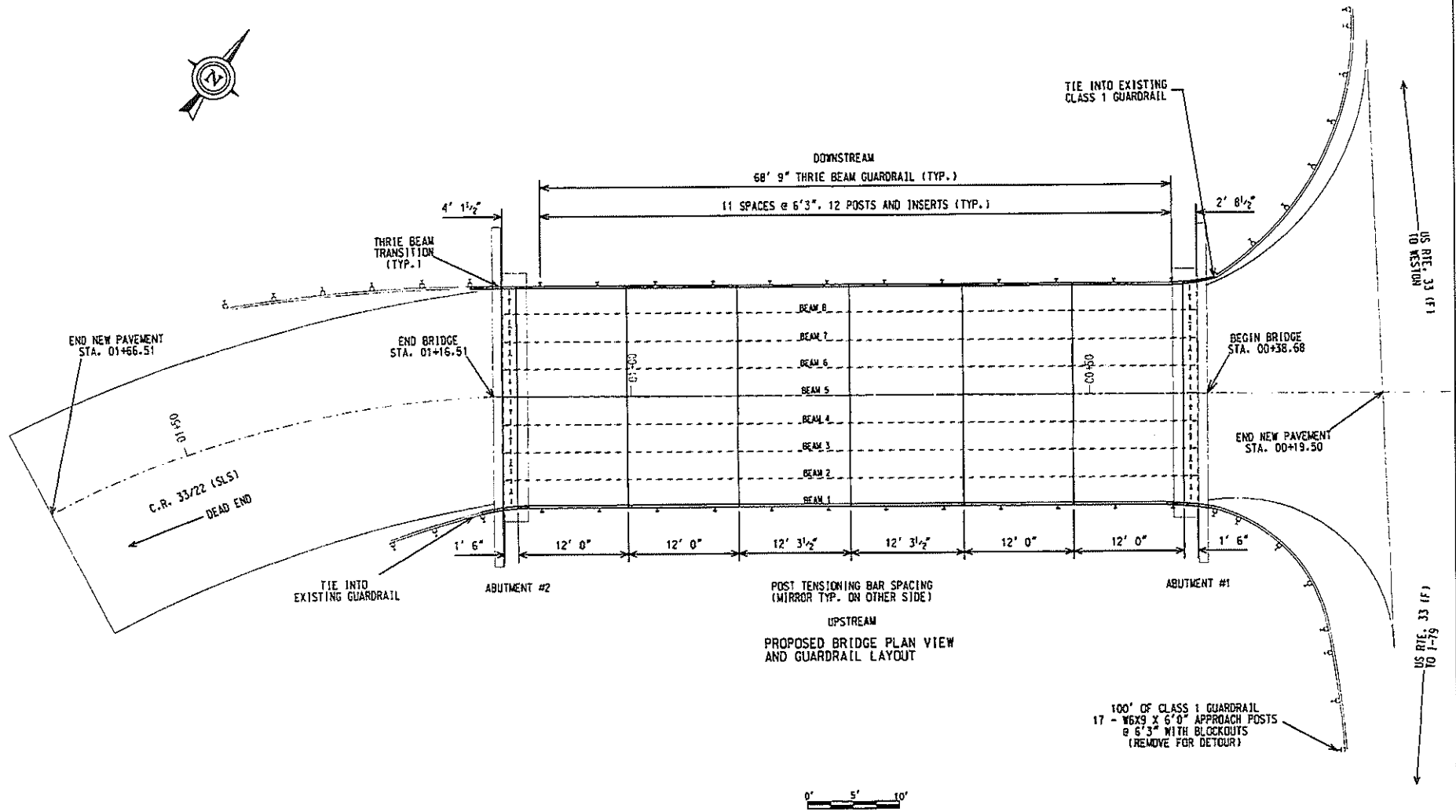

#NOTE: REMOVE AND REPLACE GUARDRAIL AS NEEDED.  
ALL GUARDRAIL TERMINATIONS SHOULD HAVE END TREATMENTS.  
TIE BACK INTO EXISTING GUARDRAIL.

DESIGNED BY:	LEWY	02-19				
DRAWN BY:	CHY	02-19				
CHECKED BY:	BSW					
REVIEWED BY:	CHD					
APPROVED BY:						
DATE:						

THE WEST VIRGINIA DEPARTMENT OF TRANSPORTATION  
DIVISION OF HIGHWAYS  
PROPOSED BRIDGE PLAN VIEW  
& GUARDRAIL LAYOUT

Public	State	State	Federal	Fiscal	County	Sheet	Total
Drawn	Dist.	Project	Project	Year		No.	Sheets
V.V.	7	5221	N/A	2020	LEWIS	7	15
		(C.O.)					

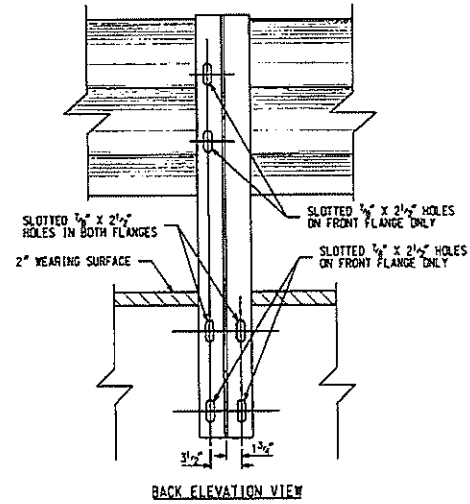
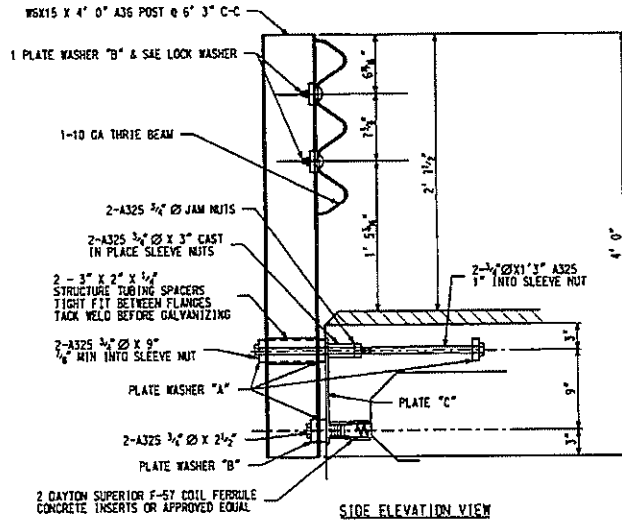

SIDE MOUNTED POST DETAILS  
OREGON THRIE-BEAM SIDE MOUNT (TL-2)  
NO SCALE

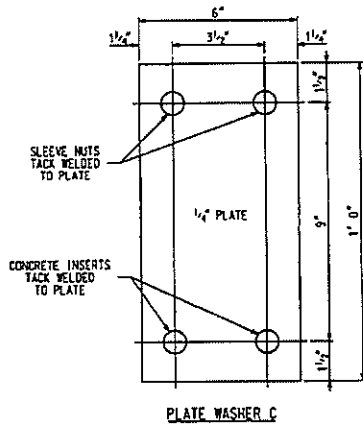

PLATE WASHER C

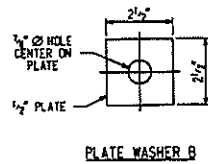

PLATE WASHER B

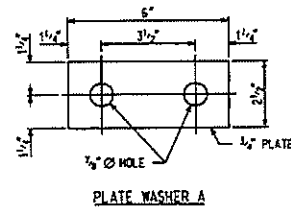
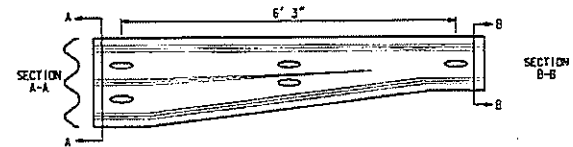

PLATE WASHER A



ASYMMETRICAL THRIE BEAM TRANSITION  
NO SCALE

NOTE: ALL GUARDRAIL FASTENERS SHALL BE GALVANIZED ACCORDING TO THE COATING SPECS. IN AASHTO M232 AND THE STEEL SECTIONS AND PLATES SHALL BE GALVANIZED ACCORDING TO AASHTO M1110

DESIGNED BY:	CMH	12-19					
DRAWN BY:	CMH	12-19					
CHECKED BY:	BMH						
REVIEWED BY:	DMB	12/20/20					

THE WEST VIRGINIA DEPARTMENT OF TRANSPORTATION  
DIVISION OF HIGHWAYS  
SIDE MOUNT AND STRUCTURE MOUNT  
GUARDRAIL DETAILS



Public Works Dist.	State Dist. No.	State Project No.	Federal Project No.	Fiscal Year	County	Sheet No.	Total Sheets
W.V. 7		5321 33/22 0.01	N/A	2020	LEWIS	8	16

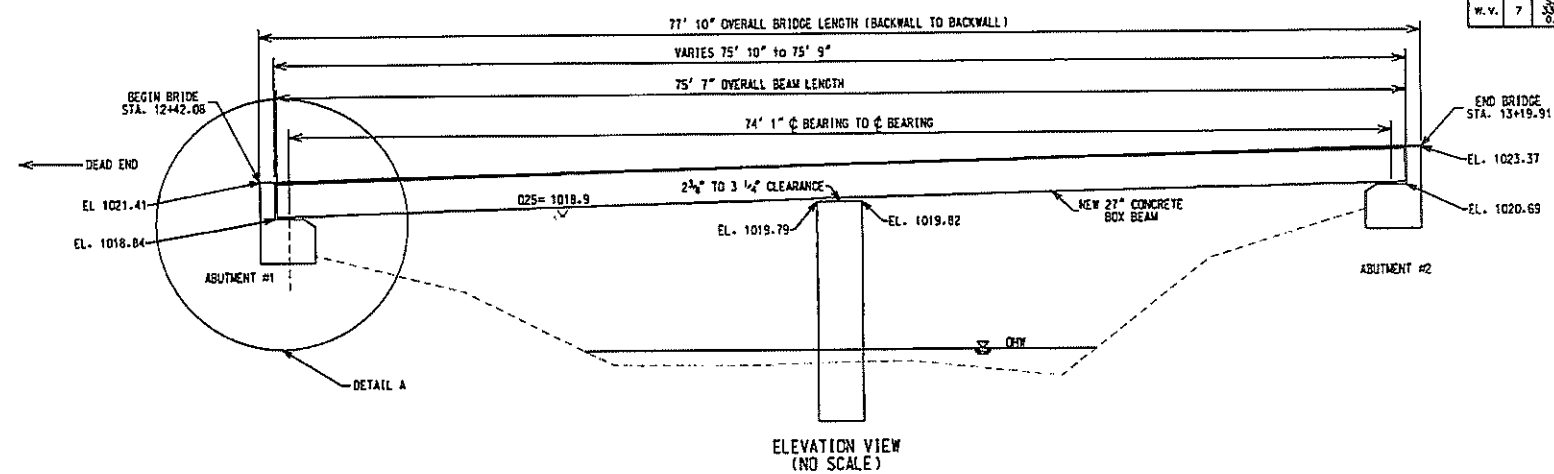

ELEVATION VIEW  
(NO SCALE)

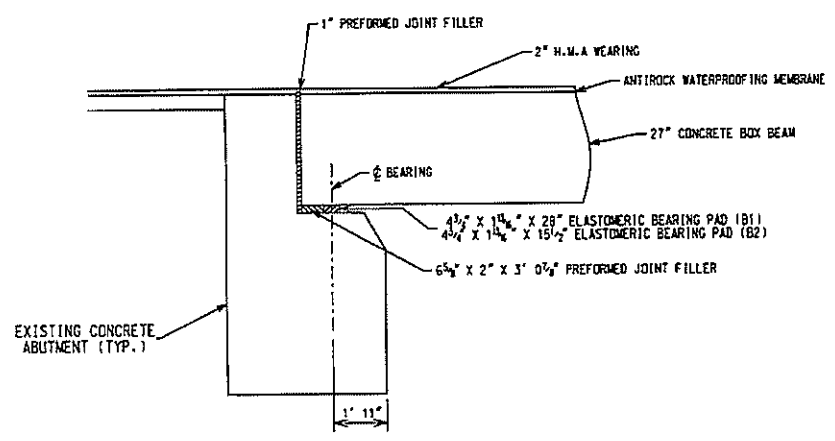

DETAIL A  
(NO SCALE - TYP. BOTH ABUTMENTS)

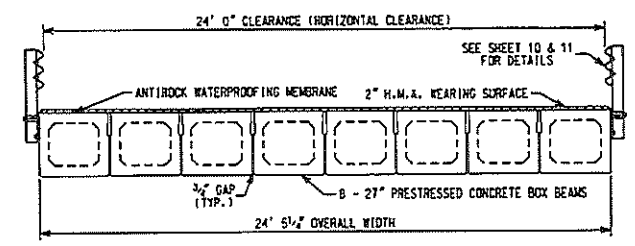

NEW PROPOSED DECK SECTION

DESIGNED BY:	CHKD:	DATE:	REVISION	DATE	BY
CJM	CJM	12-19			
CJM		12-19			
RMP					
DME					

THE WEST VIRGINIA DEPARTMENT OF TRANSPORTATION  
 DIVISION OF HIGHWAYS  
 ELEVATION VIEW, STRUCTURE  
 & PROP. DECK SECTION

FED. ROAD DIST. NO.	STATE DIST. NO.	PROJECT NUMBER	COUNTY	SHEET NO.	TOTAL SHEETS
W.VA.	7	5321-33/22-0-01	LEWIS	9	16

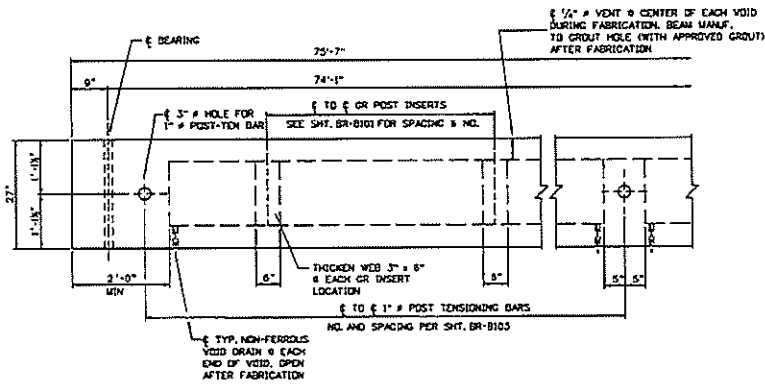

GENERAL ELEVATION VIEW

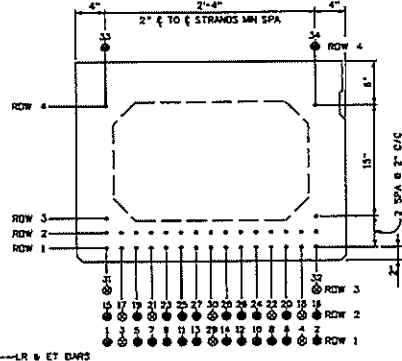

BEAM PRESTRESSING  
TYPICAL BEAM END & MIDSPAN

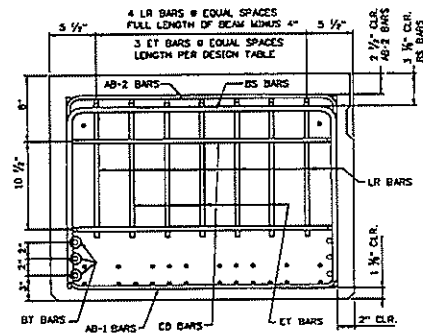

SECTION A-A

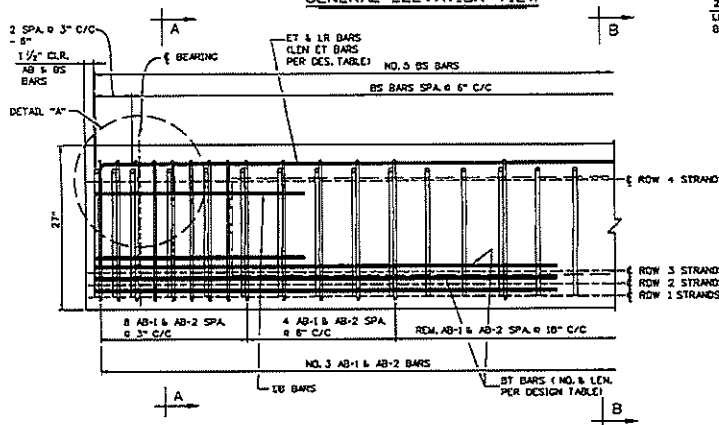

REINFORCING STEEL ELEVATION

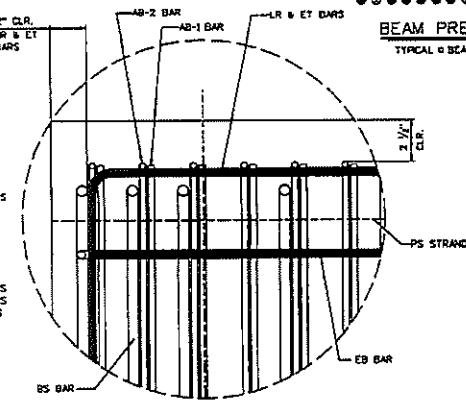

DETAIL "A"

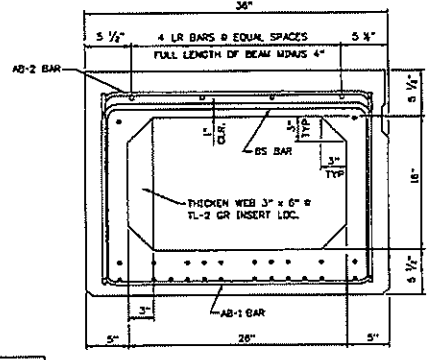

SECTION B-B

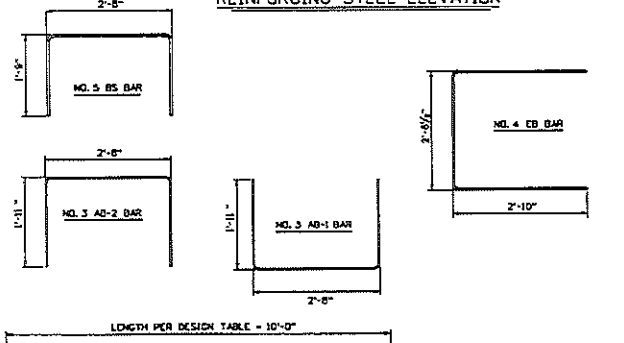

REINFORCING BAR DETAIL

**NOTES:**

- REFER TO SHEET BR-B102A FOR SHEAR KEY DETAILS.
- DESIGNER SHALL USE THE FOLLOWING KEY TO INDICATE STRAND AND DEBONDING PATTERN ON "BEAM PRESTRESSING VIEW", THIS SHEET.
  - — ACTIVE STRAND
  - ▽ — DEBOND STRAND LENGTH FROM END OF BEAM
  - △ — DEBOND STRAND LENGTH FROM END OF BEAM
  - — DEBOND STRAND LENGTH FROM END OF BEAM
- THIS SHEET SHALL BE USED IN CONJUNCTION WITH STANDARD SHEETS BR-B270, BR-B100, BR-B101, BR-B102A & B, BR-B103, BR-B104, BR-B105A & B AND BR-B106 AS APPLICABLE.

WHEN A POST-TENSION ACCESS POINT IS USED AS DETAILED ON SHEET BR-103 STRANDS IN ROWS 3 AND 4 SHALL BE ELIMINATED. THE BEAM SHALL BE REDESIGNED AS NECESSARY.

APPROVED: *[Signature]* DATE: 12-22-01  
DIRECTOR, ENGINEERING DIVISION

WEST VIRGINIA DEPARTMENT OF TRANSPORTATION  
DIVISION OF HIGHWAYS  
ENGINEERING DIVISION

27" PRESTRESSED CONCRETE  
BOX BEAMS  
DESIGN AND ASSEMBLY DETAILS

STANDARD SHEET BR-B27A

PREPARED: 12-03-10

WEST VIRGINIA DEPARTMENT OF TRANSPORTATION  
DIVISION OF HIGHWAYS  
ENGINEERING DIVISION

CONSTRUCTION PLANS OF  
HOPE STATION SUPERSTRUCTURE  
REPLAC. ON C.R. 33/22 (SLS)  
OVER STONECOAL CREEK  
LEWIS COUNTY

27" PRESTRESSED BOX BEAM  
DESIGN AND ASSEMBLY DETAILS

DESIGNED BY: CWH  
DRAWN BY: CWH  
CHECKED BY: RSW  
REVIEWED BY: CHD  
DATE: 12-10  
SCALE:  
SHEET 9 OF 16  
PROJECT NO. 5321-33/22-0-01

DESIGN DATA FOR 27" DEPTH ADJACENT BOX BEAM

FEDERAL PROJECT NO. / STATE DIST. NO. / COUNTY	PROJECT NUMBER	COUNTY	SHEET NO.	TOTAL SHEETS
W. VA. / 7	S321-33/22-0-01	LEWIS	10	16

MIN. CONCRETE STRENGTH @ RELEASE = 5500 PSI  
 MIN. CONCRETE STRENGTH @ 28 DAYS = 8000 PSI  
 INITIAL PULL/STRAND = 33,820 LBS  
 CROSS-SECTION AREA/STRAND = 0.167 SQ. IN.

SPAN LENGTH @ TO @ BEARING	40'-0"	42'-0"	44'-0"	46'-0"	48'-0"	50'-0"	52'-0"	54'-0"	56'-0"	58'-0"	60'-0"	74'-1"
OVERALL LENGTH OF BEAM	41'-6"	43'-6"	45'-6"	47'-6"	49'-6"	51'-6"	53'-6"	55'-6"	57'-6"	59'-6"	61'-6"	75'-7"
NO. OF 270 KSI, 1/2" # LOW-RELAXATION STRANDS, AREA/STRAND = 0.167 SQ. IN.	10	10	12	12	12	14	14	14	16	16	18	24
STRAND POSITION NUMBER	ROW 1	1,2,11,12	2,11,12	1,2,7,8,13,14	1,2,7,8,13,14	1,2,7,8,13,14	1,2,7,8,13,14	1,2,7,8,13,14	1,2,5,6,9,10,13,14	1,2,5,6,9,10,13,14	1,2,5,6,9,10,13,14	1,2,5,6,7,8,9,10,11,12,13,14
	ROW 2	15,16,25,26	16,16,25,26	15,16,27,28	15,16,27,28	15,16,27,28	15,16,27,28	15,16,27,28	15,16,21,22,27,28	15,16,21,22,27,28	15,16,21,22,27,28	15,16,19,20,23,24,25,26,27,28
	ROW 3											
	ROW 4	33,34	33,34	33,34	33,34	33,34	33,34	33,34	33,34	33,34	33,34	33,34
PRESTRESSING FORCE IMMEDIATELY AFTER STRAND RELEASE, P <sub>01</sub> , (KIPS/BEAM)	329	329	393	393	393	393	456	457	519	519	581	771
EFFECTIVE PRESTRESSING FORCE AFTER ALL LOSSES, P <sub>0e</sub> , (KIPS/BEAM)	301	302	356	356	357	368	411	413	463	463	514	700.5
REQUIRED FACTORED MOMENT @ STRENGTH I, M <sub>u</sub> (FT-KIPS/BEAM)	563	600	660	717	772	829	892	946	1007	1069	1132	1346.6
FACTORED FLEXURAL RESISTANCE, M <sub>r</sub> (FT-KIPS/BEAM)	708	708	888	888	866	888	1011	1011	1164	1164	1299	1802.1
TOTAL NO. DEBONDED STRANDS												
DEBONDED STRAND POSITION NUMBER & SHIELDING LENGTH FROM EACH END	ROW 1											
	ROW 2											
NUMBER & LENGTH #4 EY TOP TENSION BARS @ EACH END	3 - #4 x 5'-0"	3 - #4 x 5'-6"	3 - #4 x 6'-0"	3 - #4 x 6'-0"	3 - #4 x 6'-0"	3 - #4 x 6'-6"	3 - #4 x 6'-6"	3 - #4 x 7'-0"	3 - #4 x 7'-0"	3 - #4 x 7'-0"	3 - #4 x 7'-6"	3 - #4 x 9'-8"
NUMBER & LENGTH #5 BY BOTTOM TENSION BARS @ EACH END	8 - #5 x 7'-0"	8 - #5 x 7'-6"	8 - #5 x 7'-0"	8 - #5 x 7'-0"	8 - #5 x 7'-0"	6 - #5 x 7'-0"	6 - #5 x 7'-0"	6 - #5 x 7'-0"	4 - #5 x 7'-0"	4 - #5 x 7'-0"	4 - #5 x 8'-0"	4 - #5 x 10'-0"
DESIGN CAMBER # # POSITIVE (UP) (INCHES)	@ RELEASE	0.15	0.13	0.23	0.23	0.22	0.21	0.33	0.32	0.48	0.47	0.82
	@ ERECTION	0.15	0.15	0.34	0.34	0.28	0.24	0.42	0.37	0.64	0.68	1.56
	@ FINAL	0.13	0.07	0.14	0.22	0.14	0.04	0.20	0.13	0.4	0.30	1.55
NUMBER & SPACING OF TL-2 GUARDRAIL INSERTS	NO OF INSERTS REQ'D.											12
	END OF BEAM TO @ OF FIRST INSERT EA. END											2'-8 1/2" - A1 4'-1 1/2" - A2
SEE NOTE 6	@ OF 1st INSERT TO @ OF 2nd INSERT EA. END											6'-3"
WEIGHT OF TYPICAL BEAM INCLUDING DIAPHRAGM (TDMS)	13.6	14.4	18.0	18.7	18.3	18.9	17.8	18.1	18.7	19.3	19.9	23.75

**NOTES:**  
 1. BEAM WEIGHTS LISTED IN THE DESIGN TABLE ARE BASED ON ZERO SKEW, 2 FT. LONG ENDBLOCK AND DIAPHRAGM SPACED @ 15 FT. C/C. WEIGHTS FOR SKEWED BEAMS, LONGER ENDBLOCKS AND ADDITIONAL DIAPHRAGMS SHOULD BE ADJUSTED ACCORDINGLY.  
 FOR ADDITIONAL DIAPHRAGMS, ADD 361 LBS/DIAPHRAGM.  
 FOR SKEW ADD 27 LBS/DEGREE OF SKEW/END.  
 FOR LONGER ENDBLOCK, ADD 433 LBS/LF/END.  
 2. DESIGNERS SHOULD NOTE THAT DATA IN STANDARD TABLE IS BASED ON EVEN SPAN LENGTHS, A TWO-LANE STRUCTURE @ BEAMS WIDE AND ZERO SKEW. SUPERIMPOSED DEAD LOADS INCLUDE TYPE F PARAPET (321 PLF) AND A FWS OF 50 PSF. FOR NON-STANDARD BRIDGES DATA SHOULD BE VERIFIED AND IF REQUIRED NEW DESIGN DATA ENTERED INTO BLANK COLUMNS. IN NO CASE SHALL THE STANDARD DESIGN TABLE BE ALTERED.  
 3. PREDICTED DESIGN CAMBER VALUES LISTED IN THE TABLE ARE BASED ON EMPIRICAL FORMULAS AND AS SUCH ARE APPROXIMATE. FOR MEMBERS WITH SPAN-TO-DEPTH RATIOS AT OR EXCEEDING 25, THE TOLERANCE VALUES LISTED IN APPENDIX B OF PCI MANUAL FOR QUALITY CONTROL, MNL-116, MAY NOT APPLY. MEASUREMENT OF CAMBER FOR COMPARISON TO PREDICTED DESIGN VALUES SHOULD BE COMPLETED WITHIN 72 HOURS OF RELEASE. ADDITIONALLY, CAMBER SHOULD BE EVALUATED UNDER CONDITIONS THAT MINIMIZE THE EFFECT OF TEMPERATURE VARIATION.

4. DESIGNER, FABRICATOR, AND ERECTOR SHALL BE AWARE THAT SKEWED END BEAMS MAY TWIST OR WARP, CAUSING UNEVEN BEAM SEATING AT THE BEARINGS. THE CONTRACTOR IS REQUIRED TO CORRECT AT THE TIME OF ERECTION, BEFORE THE BEAMS ARE SECURED IN PLACE. METHOD OF CORRECTION SHALL PROVIDE AN EVEN, TOTAL BEARING AND A LEVEL TOP BEAM SURFACE. TOLERANCE, AFTER CORRECTION, SHALL BE 1/4" INCH. THE FABRICATOR SHALL NOTIFY THE CONTRACTOR AND DESIGNER IF CORRECTIONS ARE REQUIRED PRIOR TO SHIPMENT.  
 5. MAXIMUM BEAM SKEW SHALL BE 30 DEGREES.  
 6. DESIGNER INPUT VALUES OF NUMBER OF INSERTS, DISTANCE FROM END OF BEAM TO @ FIRST INSERT, AND @ FIRST INSERT TO @ SECOND INSERT. ABOVE VALUES SHALL BE BASED ON THE REQUIRED 6'-3" GUARDRAIL POST SPACING ACROSS THE BRIDGE.  
 7. THIS SHEET SHALL BE USED IN CONJUNCTION WITH STANDARD SHEETS BR-B27A, BR-B100, BR-B101, BR-B102A & B, BR-B103, BR-B104, BR-B105A & B AND BR-B106 AS APPLICABLE.

DESIGNED BY: *James R. Smith*  
 CHECKED BY: *James R. Smith*  
 DATE: 12-03-19  
 WEST VIRGINIA DEPARTMENT OF TRANSPORTATION  
 DIVISION OF HIGHWAYS  
 ENGINEERING DIVISION  
 DESIGN TABLE FOR 27"  
 PRESTRESSED BOX BEAM  
 STANDARD SHEET BR-B27B

WEST VIRGINIA DEPARTMENT OF TRANSPORTATION  
 DIVISION OF HIGHWAYS  
 ENGINEERING DIVISION

CONSTRUCTION PLANS OF  
 HOPE STATION SUPERSTRUCTURE  
 REPLACEMENT ON C.R. 33/22 (SLS)  
 OVER STONECOAL CREEK  
 LEWIS COUNTY

DESIGN TABLE FOR 27"  
 PRESTRESSED BOX BEAM

DESIGNED BY: *James R. Smith*  
 CHECKED BY: *James R. Smith*  
 DATE: 12-03-19  
 SHEET NO. 10 OF 16

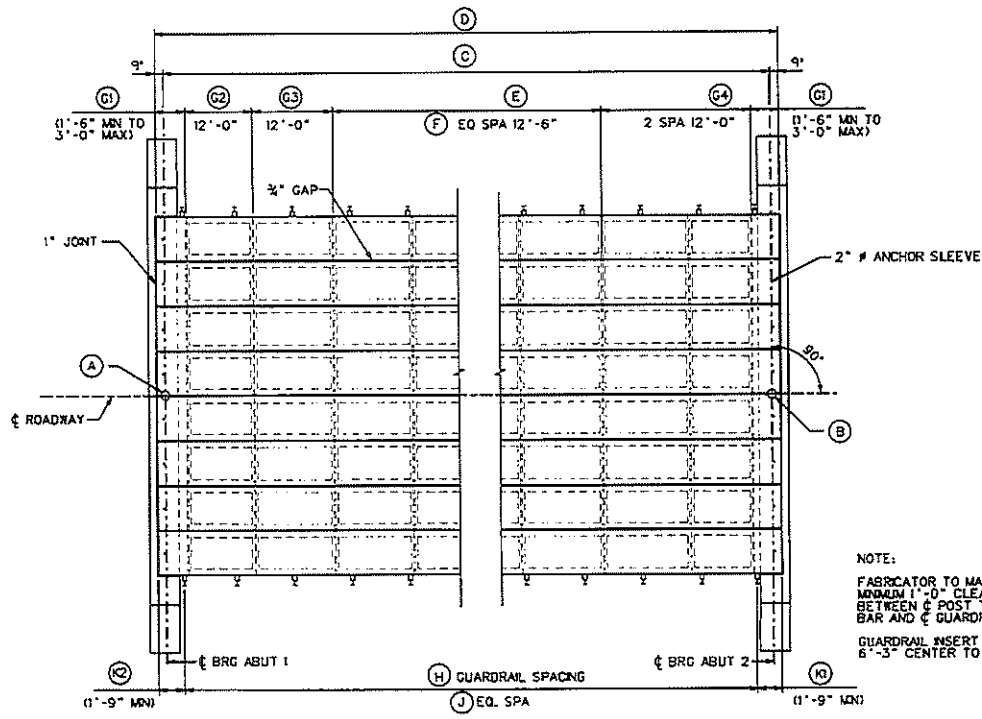

CONCRETE ADJACENT BOX BEAM CONTROL POINTS		
CODE	DESCRIPTION	DIMENSION
A	WP STA	00+40.51
B	WP STA	01+14.68
C	BEARING TO BEARING LENGTH	74'-1"
D	OVERALL BEAM LENGTH	73'-7"
E	LENGTH POST TENSION SLEEVE SPACING (12'-6")	12'-6"
F	NUMBER OF EQUAL SPACING P. T. SLEEVE (12'-6")	2
G1	LENGTH FROM END OF BEAM TO FIRST SLEEVE	1'-6"
G2	LENGTH BETWEEN FIRST SLEEVE AND SECOND	12'-0"
G3	LENGTH BETWEEN SECOND AND THRD SLEEVE	12'-0"
G4	LENGTH FROM LAST SLEEVE TO END OF BEAM	1'-6"
H	OVERALL LENGTH OF GUARDRAIL AT 6'-3" SPACING	68'-9"
J	NUMBER OF EQUAL SPACING GUARDRAIL INSERTS	12
K1	DISTANCE FROM END OF BEAM TO FIRST INSERT	2'-8 3/4"
K2	DISTANCE FROM LAST INSERT TO END OF BEAM	4'-1 1/2"
L	OVERALL WIDTH (INCLUDES 1/2" GAP)	24'-5 1/2"
M	THICKNESS OF WEARING AT CENTERLINE	2"
N	THICKNESS OF WEARING AT EDGE OF DECK	2"
O	NUMBER OF BEAMS	8
P	BEAM SIZE (WIDTH x DEPTH)	36" x 27"

NOTE:  
FABRICATOR TO MAINTAIN  
MINIMUM 1'-0" CLEARANCE  
BETWEEN P T POST TENSION  
BAR AND GUARDRAIL INSERT  
GUARDRAIL INSERT SPACING  
6'-3" CENTER TO CENTER

	GROUT STRENGTH TABLE	
	3 DAY (90%)	7 DAY (95%)
PRE-TEST STRENGTH		
JOB CONTROL STRENGTH		
GROUT TYPE & MANUFACTURER		

POST-TENSIONING BAR LENGTH		
BAR	FORMULA	LENGTH
Z	$2L + 3d$	
V	$2L + 3d$	27'-0"
WOOD		2'-0"

BAR	CODE	CALC.	ELONGATION (INCHES)											
			MEASURED											
			NO. 1	NO. 2	NO. 3	NO. 4	NO. 5	NO. 6	NO. 7	NO. 8	NO. 9	NO. 10	NO. 11	
Z	(Z)	1"												
V	(V)	1/4"												
CALCULATED (Z) = 997.3 / 24.8			DOD NO. BEAMS											
CALCULATED (V) = 997.3 / 99.2			CALCULATED (V) = 997.3 / 31 / 99.2											

FINAL POST-TENSIONING FORCE  
TYPE Z BARS = 80 KIPS  
TYPE V BARS = 40 KIPS

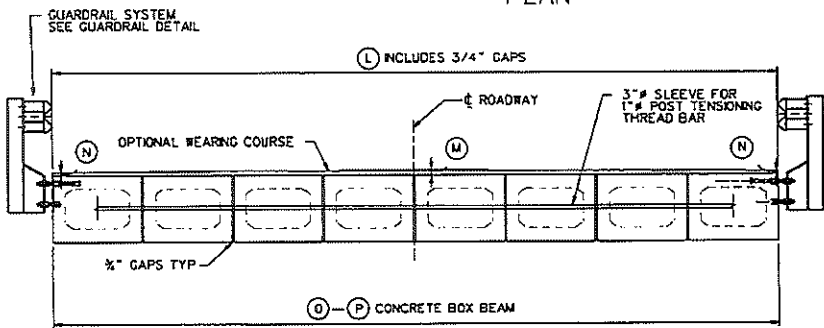

CHECK GUARDRAIL INSERT AND POST TENSION SLEEVE OVERLAP																
LOCATION FROM END OF BEAM	1	2	3	4	5	6	7	8	9	10	11	12	13	14	15	17
GUARDRAIL INSERT LOCATION	2'-8 3/4"	8'-11 1/2"	13'-2 1/4"	21'-5 1/2"	27'-8 1/2"	33'-11 1/2"	40'-2 1/2"	46'-5 1/2"	52'-8 1/2"	58'-11 1/2"	65'-2 1/2"	71'-5 1/2"				
POST TENSIONING SLEEVE LOCATION	1'-6"	13'-6"	25'-6"	37'-6"	50'-1"	62'-1"	74'-1"									

NO SLEEVE ORDNATE SHOULD BE WITHIN 1'-0" OF GUARDRAIL INSERT  
IT SHOULD BE VERIFIED BY THE DESIGNER THAT THERE IS NO CONFLICT BETWEEN  
THE GUARDRAIL INSERT, POST TENSIONING SLEEVE AND ANY SUBSTRUCTURE UNIT

WEST VIRGINIA DEPARTMENT OF TRANSPORTATION DIVISION OF HIGHWAYS				DESIGNED CRH	DATE 12-19	CHECKED RMK	DATE 12-19	CONSTRUCTION PLANS OF HOPE STATION SUPERSTRUCTURE REPLACEM. ON C.R. 33/22 (SLS) OVER STONECOAL CREEK OF LEWIS COUNTY				STANDARD BRIDGE PLANS CONCRETE ADJACENT BOX BEAM NO SKEW (3000FR1) SHEET NUMBER 11 OF 16			
NO.	REVISION	DATE	BY	DRAWN CWH	DATE 12-19	REVIEWED CMB	DATE 12-19								

**GOVERNING SPECIFICATIONS**

THE WEST VIRGINIA DEPARTMENT OF TRANSPORTATION, DIVISION OF HIGHWAYS STANDARD SPECIFICATION FOR ROADS AND BRIDGES, ADOPTED 2017 AS AMENDED BY THE CURRENT SUPPLEMENTAL SPECIFICATIONS. THE CONTRACT PLANS AND CONTRACT SPECIAL PROVISIONS ARE THE GOVERNING PROVISIONS APPLICABLE TO THIS PROJECT.

ALL BEAMS ARE DESIGNED IN ACCORDANCE WITH THE AASHTO LRFD BRIDGE DESIGN SPECIFICATIONS, DATED 1998 AS AMENDED BY THE 2003 INTERIM SPECIFICATIONS.

**DESIGN NOTES**

ALL STANDARD ADJACENT PRESTRESSED CONCRETE BRIDGE BEAMS ARE DESIGNED TO MEET THE FOLLOWING CRITERIA:

**1. DESIGN LOADS:**

HL-93 LIVE LOAD IN ACCORDANCE WITH THE AASHTO LRFD BRIDGE DESIGN SPECIFICATIONS.

FUTURE WEARING SURFACE OF 50 PSF OF ROADWAY.

DIAPHRAGM DEAD LOAD, NUMBER REQUIRED BASED ON 15'-0" MAX. SPACING.

**2. TWO LANE BRIDGE WITH AN OVERALL WIDTH OF 24'-5" (INCL. " GAP BETWEEN ADJ. BEAMS), A CURB-TO-CURB WIDTH OF 22'-1", TRANSVERSE POST-TENSIONING, AND ZERO SKEW.**

**3. DESIGN STRENGTH AND LIMIT STRESSES:**

MINIMUM CONCRETE STRENGTH @ STRAND RELEASE 5500 PSI  
 MINIMUM CONCRETE STRENGTH @ 28 DAYS 8000 PSI

**TEMPORARY STRESS LIMITS IN CONCRETE BEFORE LOSSES:**

COMPRESSION STRESS LIMIT @ STRAND RELEASE 3600 PSI  
 TENSION STRESS LIMIT @ STRAND RELEASE -200 PSI

**COMPRESSIVE STRESS LIMITS IN CONCRETE @ SERVICE I AFTER LOSSES:**

@ FINAL 1 (PS-DL+LL) 4800 PSI  
 @ FINAL 2 (PS-DL) 3600 PSI  
 @ FINAL 3 [50%(PS-DL)+LL] 3200 PSI

**TENSILE STRESS LIMIT IN CONCRETE @ SERVICE II AFTER LOSSES:**

@ FINAL 1 (PS-DL+LL) -270 PSI  
 TENSION STRESS LIMIT PRIOR TO TRANSFER: 202.5 KSI  
 TENSION STRESS LIMIT AFTER ALL LOSSES: 194.4 KSI

**4. DEBONDING OR SHIELDING OF STRANDS TO REDUCE TEMPORARY TENSILE STRESSES IS PERMITTED, HOWEVER DEBONDING IS LIMITED TO 40% PER ROW AND 25% TOTAL. IN NO INSTANCES SHALL OUTER STRANDS BE DEBONDED. DEBONDED STRANDS SHALL BE SEPARATED BY AT LEAST ONE FULLY BONDED STRAND AND SHALL BE SYMMETRICAL ABOUT THE C OF THE BEAM. SHIELDING OF STRANDS SHALL BE ACCOMPLISHED BY TAPING OR TIGHTFITTING PLASTIC TUBES TAPED AT EACH END.**

**5. THE ELASTOMERIC BEARING PADS PROVIDED IN THE STANDARD DESIGNS ARE BASED ON ZERO GRADE AND ARE LIMITED TO A MAXIMUM OF 5% GRADE. IN INSTANCES OF GRADES EXCEEDING THIS LIMIT, PADS SHALL BE SPECIFICALLY DESIGNED. INDIVIDUAL PAD DESIGNS SHALL BE IN ACCORDANCE WITH SECTION 14, AASHTO LRFD. BEVELED SOLE PLATES ARE PERMITTED.**

**6. MAXIMUM BEAM SKEW SHALL BE 30 DEGREES.**

**7. WHEN ALTERNATE DESIGNS OR SITE SPECIFIC DESIGNS ARE PROVIDED, CRITERIA SET FORTH IN THESE STANDARDS SHALL APPLY.**

**8. NEGATIVE DESIGN CAMBER AFTER ALL LOSSES IS NOT PERMITTED.**

**9. EACH BEAM PROVIDED IN THESE STANDARD DESIGNS HAS BEEN LOAD RATED IN ACCORDANCE WITH SECTION 3.15 OF THE WEST VIRGINIA DIVISION OF HIGHWAYS BRIDGE DESIGN MANUAL. ADDITIONALLY, LOAD RATING PROCEDURES ARE IN ACCORDANCE WITH THE AASHTO MANUAL FOR CONDITION EVALUATION AND LOAD AND RESISTANCE FACTOR RATING OF HIGHWAY BRIDGES, 2003.**

**MATERIAL AND FABRICATION NOTES (CONT'D)**

THE PRESTRESSED CONCRETE BEAMS SHALL CONFORM TO ALL APPLICABLE PROVISIONS OF SECTION 603 OF THE STANDARD SPECIFICATIONS.

**MILD REINFORCEMENT:**

ALL MILD REINFORCING STEEL SHALL BE GRADE 60, DEFORMED BILLET STEEL AND SHALL BE EPOXY COATED EXCEPT WHERE NOTED. ALL UNCOATED REINFORCING SHALL MEET THE REQUIREMENTS OF AASHTO M31. ALL EPOXY COATED REINFORCING SHALL MEET THE REQUIREMENTS OF AASHTO M284, EXCEPT WHERE AMENDED BY SECTION 709.1 OF THE STANDARD SPECIFICATIONS.

ALL TENSION LAP SPLICES SHALL BE A CLASS B, CONTACT TYPE. MINIMUM LAP SPLICE LENGTHS SHALL BE AS GIVEN IN THE "LAP SPLICE TABLE", THIS SHEET. ADDITIONALLY, IF LAP SPlicing OF ET, LR, AND BT BARS IS USED, TERMINATION OF THE SPLICE SHALL BE NO CLOSER TO THE END OF THE BEAM THAN 1/10 OF THE SPAN LENGTH.

MINIMUM BAR BENDING DIAMETER SHALL BE 6 BAR DIAMETERS, EXCEPT THAT NO. 4 AB BARS MAY HAVE A MINIMUM BEND DIAMETER OF 4 BAR DIAMETERS.

MINIMUM CONCRETE COVER SHALL BE AS SPECIFIED IN SECTION 603.5 OF THE STANDARD SPECIFICATIONS, EXCEPT WHERE NOTED ON THE PLANS.

**PRESTRESSING STRAND:**

ALL PRESTRESSING STEEL SHALL BE 1/2" DIAMETER, GRADE 270, 7 WIRE UNCOATED, LOW-RELAXATION STRAND MEETING THE REQUIREMENTS OF AASHTO M203, SUPPLEMENT S1.

ALL BEAMS DESIGNED IN THESE STANDARDS UTILIZE STRANDS WITH A NOMINAL AREA OF 0.167 SQ. IN.

STRANDS WITH A NOMINAL AREA OF 0.153 SQ. IN. IS PERMITTED FOR INDIVIDUAL OR ALTERNATE DESIGNS.

HOWEVER THE DESIGNER IS ENCOURAGED TO USE THE LARGER STRAND FOR UNIFORMITY REASONS. IN NO CASES WILL STRESS-RELIEVED STRAND BE PERMITTED.

ALL STRANDS SHALL BE ENCLOSED INSIDE THE STIRRUP CAGE FOR THE FULL LENGTH OF THE BEAM.

ALL EXPOSED PRESTRESSING STRAND AT EACH BEAM END SHALL BE SHOP COATED WITH A LIQUID COLD-APPLIED BITUMINOUS ELASTOMERIC WATERPROOFING MEMBRANE. MATERIAL SHALL MEET ASTM C836-84.

**CONCRETE:**

ALL CONCRETE USED IN MANUFACTURING PRESTRESSED CONCRETE BEAMS SHALL MEET THE REQUIREMENTS OF SECTION 603.6 OF THE STANDARD SPECIFICATIONS.

DESIGN STRENGTHS SHALL MEET OR EXCEED THE MINIMUM VALUES SET FORTH IN THESE PLANS.

**ELASTOMERIC BEARING PADS:**

ALL BEARING PADS SHALL MEET THE APPLICABLE REQUIREMENTS AS SET FORTH IN SECTION 18.2 OF THE AASHTO LRFD BRIDGE CONSTRUCTION SPECIFICATIONS, 1998 EDITION WITH CURRENT INTERMS. ALL BEARINGS SHALL BE STEEL REINFORCED LAMINATED BEARINGS.

THE ELASTOMER MATERIAL SHALL BE 60 DUROMETERS WITH A MINIMUM LOW TEMPERATURE GRADE OF 3 (ZONE C).

ALL STEEL REINFORCING SHALL MEET THE REQUIREMENTS OF AASHTO M270, GRADE 36.

**WELDING:**

TACK WELDING OF REINFORCEMENT IS NOT PERMITTED. REINFORCING CAGES AND LONGITUDINAL STEEL SHALL BE ADEQUATELY TIED WITH APPROVED MEANS TO PREVENT RACKING AND MISALIGNMENT.

ALL WELDING OF FABRICATED ITEMS, AS SHOWN IN THESE PLANS SHALL BE IN ACCORDANCE WITH ALL APPLICABLE PROVISIONS OF AASHTO/AWS D1.5, 2002.

LAP SPLICE TABLE				
BAR SIZE	NO. 3	NO. 4	NO. 5	NO. 6
SPLICE LENGTH	21"	28"	34"	41"

WEST VIRGINIA DEPARTMENT OF TRANSPORTATION DIVISION OF HIGHWAYS				DESIGNED CWH	DATE 12-19	CHECKED RMW	DATE -	CONSTRUCTION PLANS OF HOPE STATION SUPERSTRUCTURE REPLACEMENT ON C.R. 33/22 (SLS) OVER STONECOAL CREEK LEWIS COUNTY	STANDARD BRIDGE PLANS ADJACENT BOX BEAM STANDARD BEAM NOTES 1 OF 2 (3000GNI) SHEET NUMBER 12 OF 16
NO.	REVISION	DATE	BY	DRAWN CWH	DATE 12-19	REVIEWED CMB	DATE -		

**MATERIAL AND FABRICATION NOTES (CONT'D)**

**GUARDRAIL, GUARDRAIL POSTS, TUBING & INSERTS:**

ALL W-BEAM GUARDRAIL AND ATTACHMENT HARDWARE SHALL BE IN ACCORDANCE WITH SECTION 712.4 OF THE STANDARD SPECIFICATIONS. GUARDRAIL POSTS, STRUCTURAL TUBING, POST ATTACHMENT INSERTS, AND HARDWARE SHALL MEET THE LISTED MATERIAL AND COATING SPECIFICATIONS:

ITEM	DESCRIPTION	MATERIAL SPEC.	COATING SPEC.
POST	W6x25	AASHTO M270, GR 36	AASHTO M111
PLATE	½" x 7"	AASHTO M270, GR 36	AASHTO M111
TUBING	TS Bx4x3/16	ASTM A500, GR B	AASHTO M111
CHANNEL	C7x9.8	AASHTO M270, GR 36	AASHTO M111
FERRULE	TYPE 2A ANCHOR	1¼" # x 2½" MIN LEN.	ASTM A108 (M17 STEEL)
WIRE		¾" #	ASTM A510 (1018 STEEL)
STUDS	TYPE 1A ANCHOR	1¼" # x 8" LONG	ASTM A108 (1045 C.D. STEEL)
NUTS		1¼" #	AASHTO M291, CLASS C
COUPLERS	TYPE 1A ANCHOR	1¼" # x 5" LONG	ASTM A108 (12L14 STEEL)
BOLTS		1¼" # x 12" LONG	AASHTO M164 (TYPE 1, HH)
BOLTS	TYPE 1A ANCHOR	¾" # x ALL LEN.	AASHTO M164 (TYPE 1, HH)
NUTS		¾" #	AASHTO M291, CLASS C
WASHERS	ALL	AASHTO M293	AASHTO M232

**POST-TENSIONING BARS:**

POST-TENSIONING THREAD BARS SHALL BE ONE INCH DIAMETER, 150 KSI STEEL, AND SHALL CONFORM TO AASHTO M275, TYPE 1. STEEL THREAD BARS SHALL BE DESIGNED TO ALLOW THE USE OF HEAVY HEX NUTS AND COUPLERS THAT THREAD ONTO THE END OF THE DEFORMATIONS. HEAVY HEX NUTS AND COUPLERS SHALL BE OF A DESIGN AND MATERIAL RECOMMENDED BY THE BAR MANUFACTURER TO DEVELOP THE FULL TENSILE STRENGTH OF THE BAR. PROPERLY DOCUMENTED CERTIFIED MILL TEST REPORTS SHALL BE PROVIDED FOR EACH HEAT OF STEEL THREAD BARS.

ALL POST-TENSIONING THREAD BARS, NUTS, BEARING PLATES, COUPLERS, AND ANCILLARY HARDWARE SHALL BE HOT-DIPPED GALVANIZED IN ACCORDANCE WITH AASHTO M111. THE GALVANIZING PLANT SHALL ADMINISTER ADEQUATE QUALITY CONTROL MEASURES TO SAFEGUARD AGAINST HYDROGEN EMBRITTLEMENT. QUALITY CONTROL MEASURES SHALL COMPLY WITH ASTM A-143. CERTIFICATION FOR HOT-DIP GALVANIZING SHALL BE PROVIDED BY THE GALVANIZING PLANT.

ALL POST-TENSIONING BEARING PLATES SHALL CONFORM TO AASHTO M270, GRADE 36.

**SHEAR KEY GROUT:**

SHEAR KEY GROUT SHALL BE A GROUT THAT IS RECOMMENDED BY THE MANUFACTURER FOR A POURABLE GROUT APPLICATION AND THAT BASED ON THE MANUFACTURER'S TEST DATA WILL ATTAIN A MINIMUM OF 4500 PSI COMPRESSIVE STRENGTH IN 3 DAYS UNDER CONDITIONS REPRESENTATIVE OF THE CONDITIONS TO BE EXPERIENCED AT THE SITE. THE GROUT MUST BE LISTED ON THE APPROVED LIST OF GROUTS PUBLISHED BY THE WEST VIRGINIA DIVISION OF HIGHWAYS, MATERIALS CONTROL, SOIL AND TESTING DIVISION. THE CONTRACTOR SHALL PRE-TEST THE PROPOSED GROUT FOR COMPRESSIVE STRENGTH AT 3 AND 7 DAYS AND SUBMIT THE RESULTS TO THE BRIDGE PROJECT MANAGER FOR APPROVAL PRIOR TO INSTALLATION OF THE GROUT IN THE STRUCTURE. THE TESTS WILL BE BASED ON A POURABLE CONSISTENCY WITH THE SAME WATER/GROUT MIXTURE RATIO TO BE USED IN THE STRUCTURE.

THE CONTRACTOR SHALL BE REQUIRED TO SUBMIT FOR EACH PROJECT, THE GROUT PRE-TEST RESULTS OBTAINED IN THE NOTE ABOVE. THE CONTRACTOR SHALL BE REQUIRED TO PERFORM A NEW PRE-TEST AND SUBMISSION FOR APPROVAL UNDER ANY OF THE FOLLOWING CONDITIONS:  
 - A PERIOD OF 18 MONTHS HAS ELAPSED SINCE LAST PRE-APPROVAL TESTING.  
 - GROUT MANUFACTURER HAS REVISED OR CHANGED THE GROUT SPECIFICATIONS.  
 - THE CONTRACTOR ALTERS THE WATER/GROUT MIXTURE RATIO.  
 - THE CONTRACTOR CHANGES GROUT MANUFACTURER.  
 - THE CONTRACTOR IS REQUIRED TO COMPLETE THE GROUT STRENGTH TABLE ON BR-1103.

TEST PROCEDURE FOR DETERMINING THE COMPRESSIVE STRENGTH OF GROUT SHALL USE CUBE SPECIMENS IN ACCORDANCE WITH ASTM C109, AS MODIFIED BY ASTM C107. GROUT TESTING IN ACCORDANCE WITH AASHTO T23 (STANDARD CYLINDER TEST) IS NOT ACCEPTABLE.

**MATERIAL AND FABRICATION NOTES (CONT'D)**

**PROTECTIVE SURFACE TREATMENT:**

EACH PRESTRESSED CONCRETE BEAM SHALL BE TREATED BY THE MANUFACTURER AT THE FABRICATION PLANT WITH AN APPROVED CONCRETE SEALER (SILANE). AN APPROVED LIST OF CONCRETE SEALERS ARE ON FILE AT THE WEST VIRGINIA DIVISION OF HIGHWAYS, MATERIALS, CONTROL, SOIL AND TESTING DIVISION. COVERAGE SHALL INCLUDE TOP AND BOTTOM OF INTERIOR BEAMS, AND TOP, BOTTOM AND EXTERIOR SIDE OF EXTERIOR BEAM. APPLICATION RATE SHALL BE PER TREATMENT MANUFACTURER'S RECOMMENDATION. AFTER COMPLETION OF THE SILANE TREATMENT BY FABRICATOR AND A MAXIMUM OF FIVE WORKING DAYS PRIOR TO SHIPMENT OF THE BEAMS, THE FABRICATOR SHALL BE RESPONSIBLE FOR ABRASIVE BLAST CLEANING TO CLEAN WHITE CONCRETE THE INTERIOR SIDES OF BEAMS FOR THE FULL LENGTH. CLEAN WHITE CONCRETE SHALL MEAN REMOVAL OF ALL DIRT, GREASE, OIL, AND LOOSE CONCRETE LAITANCE AND PROVIDE A ROUGHENED CONCRETE SURFACE. BLASTING MEDIUM SHALL BE APPROVED BY THE DIVISION OF HIGHWAYS.

**SHOP DRAWINGS:**

THE FABRICATOR SHALL BE RESPONSIBLE FOR THE PREPARATION OF SHOP DRAWINGS IN ACCORDANCE WITH THE WEST VIRGINIA DIVISION OF HIGHWAYS DOCUMENTS, DD-102 AND THE STANDARD SPECIFICATIONS.

**PROCEDURE NOTES**

- INSTALL ONE INCH THICK SPACER AND GROUT STOP BY GLUING TO ONE SIDE, FOR THE ENTIRE LENGTH OF EACH BEAM PRIOR TO SETTING BEAMS. GLUE SHALL BE AN APPROVED CONSTRUCTION TYPE GLUE OR EPOXY ADHESIVE. GROUT STOP MAY BE INSTALLED AFTER BEAMS ARE SET. GLUE A ¾" x 2" x 2" PIECE OF PRESSURE TREATED PLYWOOD AT EACH THREAD-BAR LOCATION TO ENSURE THAT A ¾" GAP IS OBTAINED. PLYWOOD SPACERS TO BE OFFSET APPROXIMATELY 2 FEET FROM THE THREAD-BAR HOLE AND CENTERED ON THE HOLE DEPTH. PLYWOOD SPACERS ARE REQUIRED ON ONLY ONE BEAM EDGE FACE OF ABUTTING BEAMS. AFTER THE BEAMS ARE SET AND THE THREAD-BARS INSTALLED, PULL THE ENTIRE SUPERSTRUCTURE TOGETHER BY APPLYING A POST-TENSIONING FORCE OF APPROXIMATELY 3000 POUNDS. AT THIS STAGE THE GAP BETWEEN BEAMS SHALL BE A UNIFORM ¾" WITH ALL SWEEP REMOVED. RECORD THE ACTUAL FORCE APPLIED.
- FILL THE GAP BETWEEN BEAMS AND SHEAR KEY FULL DEPTH WITH THE PRE-APPROVED, PRE-TESTED GROUT MIXTURE. FROM EACH BATCH, PREPARE JOB CONTROL GROUT CUBES FOR THREE AND SEVEN DAY TESTS. THESE JOB CONTROL SAMPLES WILL BE USED TO DETERMINE WHEN THE GROUT HAS ATTAINED A MINIMUM COMPRESSIVE STRENGTH OF 4500 PSI. A MINIMUM OF THREE SPECIMENS PER TEST SHALL BE OBTAINED, AND THE AVERAGE OF THE TEST RESULTS USED. ACCEPTANCE SAMPLING AND TESTING OF THE GROUT IS THE RESPONSIBILITY OF THE CONTRACTOR; HOWEVER, A REPRESENTATIVE OF THE WVDOT SHALL WITNESS ALL OF THE ACCEPTANCE SAMPLING AND TESTING.
- IN NO INSTANCE SHALL THE CONTRACTOR PROCEED WITH POST-TENSIONING OR OTHER BEAM ERECTION PROCEDURES UNTIL THE REQUIRED MINIMUM GROUT STRENGTH IS ATTAINED AND VERIFIED BY THE ENGINEER. IN THE EVENT THAT THE MINIMUM GROUT STRENGTH IS NOT ATTAINED, THE ENGINEER SHALL BE NOTIFIED AND CORRECTIVE ACTION TAKEN AT THE DIRECTION OF THE ENGINEER. SEE SHEAR KEY GROUT NOTE.
- AFTER THE GROUT HAS REACHED AN INITIAL SET CONDITION AND PRIOR TO ANY FINAL POST-TENSIONING PROCEDURES, THE CONTRACTOR SHALL REMOVE THE GROUT STOP AND INSPECT THE GROUT FOR Voids OR OTHER IRREGULARITIES. ANY Voids DEEPER THAN 2" FROM THE BOTTOM SHALL BE REGROUTED IN A MANNER ACCEPTABLE TO THE ENGINEER.
- AFTER GROUT AS BEEN PLACED AND REACHED MINIMUM COMPRESSIVE STRENGTH OF 4500 PSI AND HAS CURED A MINIMUM OF 3 DAYS, APPLY 50% OF THE FINAL POST-TENSIONING FORCE TO ALL THREAD-BARS, WORKING BEAM ENDS TO MIDSPAN. AFTER ALL THREAD-BARS HAVE BEEN TENSIONED TO 50%, APPLY THE REMAINING PERCENTAGE OF FINAL POST-TENSIONING FORCE, WORKING IN THE SAME SEQUENCE AS THE FIRST STAGE OF FINAL TENSIONING.
- MEASURE AND RECORD IN THE ELONGATION TABLE, THE ACTUAL TOTAL ELONGATION OF EACH THREAD-BAR. COMPARE THE MEASURED ELONGATION TO THE CALCULATED ELONGATION. A SIGNIFICANT DIFFERENCE BETWEEN MEASURED AND CALCULATED ELONGATIONS COULD INDICATE IMPROPER JACKING TECHNIQUES, FAULTY MATERIALS, FAULTY JACKS, OR IMPROPERLY CALIBRATED JACKS. IF THE DIFFERENCE IS GREATER THAN 15%, THEN THE JACK SHALL BE RE-CALIBRATED AND THE JACKING TECHNIQUES EVALUATED. IF, AFTER THE ABOVE STEPS ARE TAKEN, THE PERCENTAGE DIFFERENCE IS GREATER THAN 10%, THEN THE ENGINEER SHALL BE NOTIFIED AND CORRECTIVE ACTION TAKEN AT THE DIRECTION OF THE ENGINEER. ALL COSTS INVOLVED IN CORRECTION SHALL BE AT THE CONTRACTORS EXPENSE.
- USING SAW, TRIM EXCESS THREAD-BAR LEAVING 4" TO 6" PAST THE NUT. DO NOT TRIM THREAD-BARS BY TORCH CUTTING. TOUCH-UP TRIMMED ENDS WITH GALVICON OR EQUAL.
- INSTALL ANCHOR DOWELS

				WEST VIRGINIA DEPARTMENT OF TRANSPORTATION DIVISION OF HIGHWAYS				CONSTRUCTION PLANS OF HOPE STATION SUPERSTRUCTURE REPLACED ON C.R. 33/22 (SLS) OVER STONECOAL CREEK LEWIS COUNTY				STANDARD BRIDGE PLANS ADJACENT BOX BEAM STANDARD BEAM NOTES 2 OF 2 (3000GN2) SHEET NUMBER 13 OF 16			
DESIGNED	DATE	CHECKED	DATE	DRAWN	DATE	REVIEWED	DATE								
CRH	12-19														
NO.	REVISION	DATE	BY	CRH	12-19	CMB	1-20								

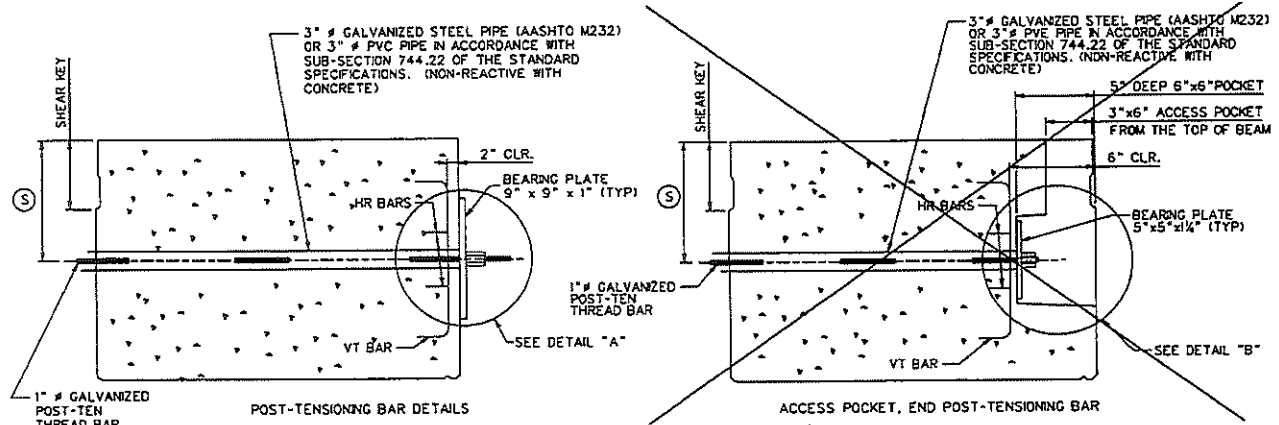

1/4" STRAND LIFTING LOOPS EMBEDDED FULL DEPTH OF BEAM MINUS COVER OF A MINIMUM OF 25 RICHES.  
 NUMBER OF STRANDS PER SIDE SHALL BE DETERMINED BY THE FABRICATOR.

2" OF 3" FOAM BLOCKOUT AFTER ERECTION. CUT STRANDS FLUSH WITH BOTTOM OF VOID AND FILL WITH GROUT MEETING THE REQUIREMENTS OF SUB-SECT. 715.5

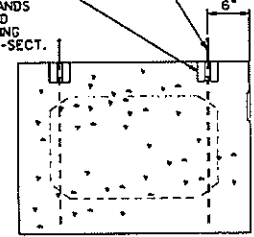

END VIEW

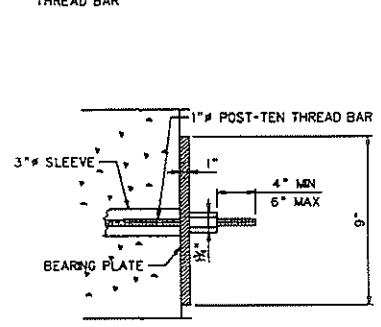

DETAIL "A"

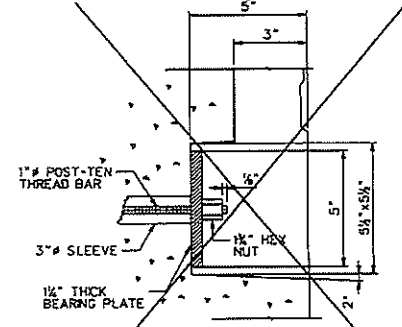

DETAIL "B"

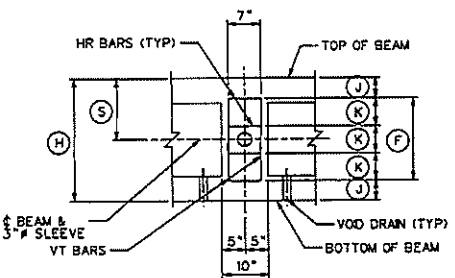

REINFORCING DETAILS @ DIAPHRAGM EXTERIOR BEAM & POCKETS ONLY

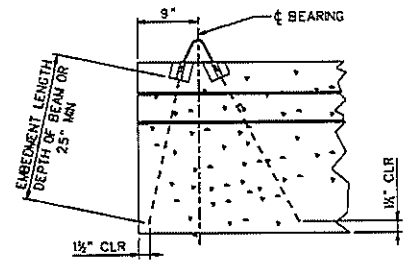

SIDE VIEW

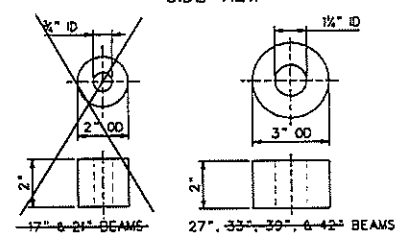

BLOCKOUT DETAILS

LIFTING DETAILS

NOT TO SCALE

NOTE:  
 SPACE POST-TENSIONING THREAD BARS TO AVOID CONFLICT WITH GUARDRAIL INSERTS.

FINAL POST-TENSIONING FORCE  
 TYPE 2 BARS = 80 KIPS  
 TYPE V BARS = 40 KIPS

SPECIAL BARRING NOTES  
 1. DO NOT STAND IN LINE WITH THE POST-TENSIONING BAR DURING TENSIONING PROCEDURES.  
 2. NUTS, COUPLERS AND EXTENSION RODS USED IN THE POST-TENSIONING WORK SHALL BE THE MATERIAL APPROVED BY THE MANUFACTURER OF THE HIGH STRENGTH POST-TENSIONING RODS. IN NO CASE SHALL THE CONTRACTOR USE NON-APPROVED MATERIAL OR MATERIAL FROM TWO DIFFERENT SOURCES.

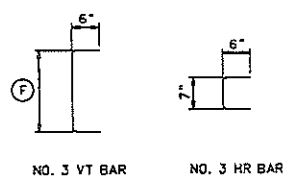

REINFORCING BAR DETAIL  
 ALL BARS GR 60 - EPOXY COATED

DIMENSIONS			
BEAM SIZE	REINFORCEMENT BAR SIZE	SPACING	DIST
24"	#4	12"	12"
24"	#5	12"	12"
24"	#6	12"	12"
24"	#7	12"	12"
24"	#8	12"	12"
24"	#9	12"	12"
24"	#10	12"	12"
24"	#11	12"	12"
24"	#12	12"	12"
24"	#13	12"	12"
24"	#14	12"	12"
24"	#15	12"	12"
24"	#16	12"	12"
24"	#17	12"	12"
24"	#18	12"	12"
24"	#19	12"	12"
24"	#20	12"	12"
24"	#21	12"	12"
24"	#22	12"	12"
24"	#23	12"	12"
24"	#24	12"	12"
24"	#25	12"	12"
24"	#26	12"	12"
24"	#27	12"	12"
24"	#28	12"	12"
24"	#29	12"	12"
24"	#30	12"	12"

NO.	REVISION	DATE	BY

WEST VIRGINIA DEPARTMENT OF TRANSPORTATION  
 DIVISION OF HIGHWAYS

DESIGNED	DATE	CHECKED	DATE
CWH	12-19	RAJK	1-20
DRAWN	DATE	REVIEWED	DATE
CWH	12-19	CMB	1-20

CONSTRUCTION PLANS OF  
 HOPE STATION SUPERSTRUCTURE  
 REPLACEM. ON C.R. 33/22 (SLS)  
 OVER STONECOAL CREEK  
 LEWIS COUNTY

STANDARD BRIDGE PLANS  
 CONCRETE ADJACENT BOX BEAM  
 MISCELLANEOUS BEAM DETAIL 1 OF 3  
 SHEET NUMBER 14 OF 16 (3000MB1)

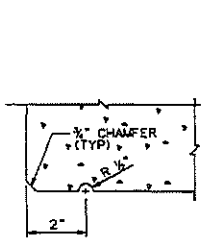

DRIP GROOVE DETAIL  
EXTERIOR BEAMS

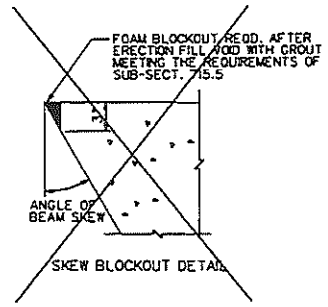

SKEW BLOCKOUT DETAIL

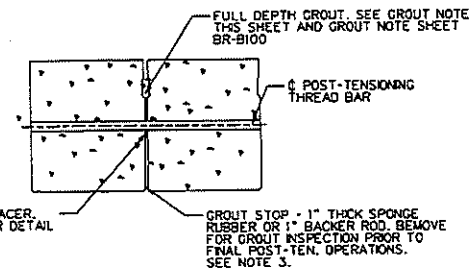

GROUT DETAILS

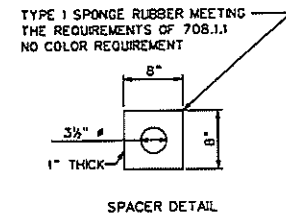

SPACER DETAIL

BEAM DEPTH	H
17"	1'-10"
21"	1'-10"
27"	1'-10"
33"	1'-10"
39"	1'-10"
45"	1'-10"

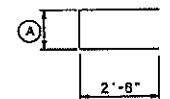

NO. 4 SS BAR

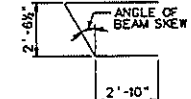

NO. 4 EB BAR

REINFORCING BAR DETAIL  
SKEWED BEAMS

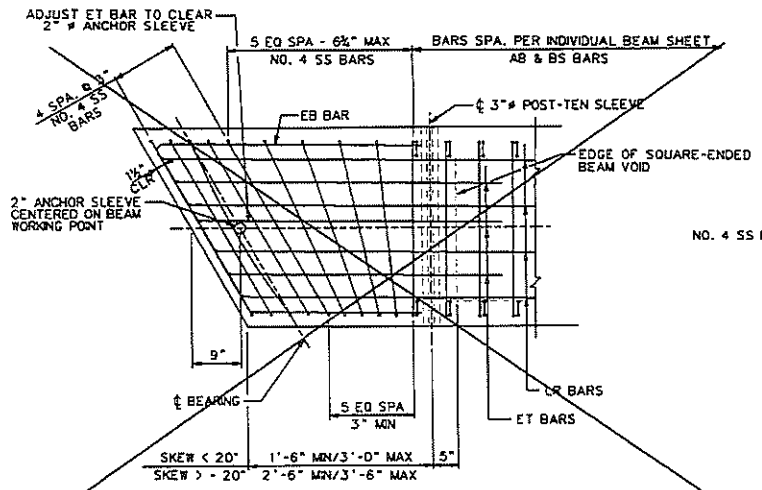

END BLOCK DETAIL - SKEWED BEAMS  
NO/POST-TEN. ACCESS POCKET

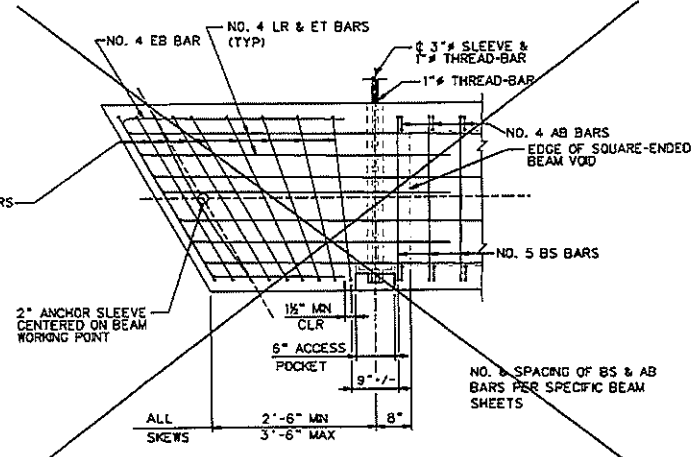

SHEAR REINFORCEMENT DETAIL  
BEAMS WITH ACCESS POCKETS

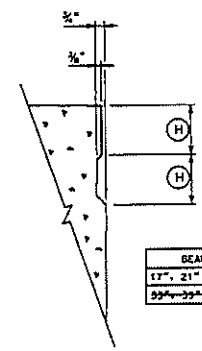

SHEAR KEY DETAIL

BEAM DEPTH	H
17", 21" & 27" BARS	4"
33", 39" & 45" BARS	6"

NOT TO SCALE

NO.	REVISION	DATE	BY

WEST VIRGINIA DEPARTMENT OF TRANSPORTATION  
DIVISION OF HIGHWAYS

DESIGNED	DATE	CHECKED	DATE
CWH	12-19	FMW	1-20
DRAWN	DATE	REVIEWED	DATE
CWH	12-19	CMB	1-20

CONSTRUCTION PLANS OF  
HOPE STATION SUPERSTRUCTURE  
REPLACED ON C.R. 33/22 (SLS)  
OVER STONECREEK CREEK  
LEWIS COUNTY

STANDARD BRIDGE PLANS  
CONCRETE ADJACENT BOX BEAM  
MISCELLANEOUS BEAM DETAIL 2 OF 3  
SHEET NUMBER 15 OF 16 (3000MB2)



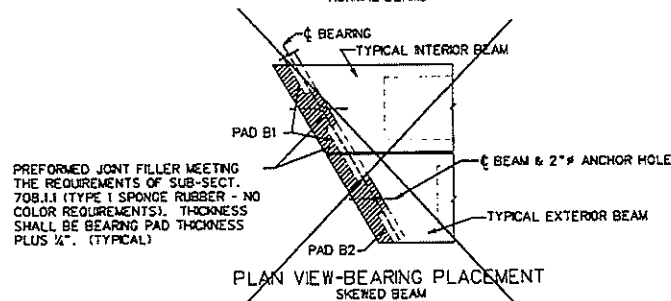
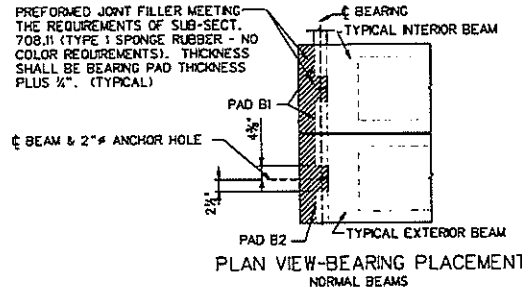
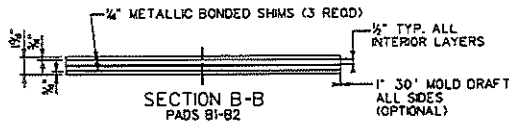
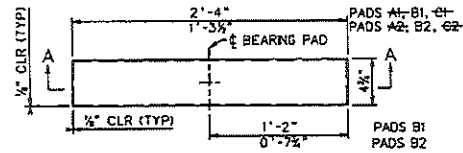

**NOTES:**

- ELASTOMERIC BEARING PADS ARE DESIGNED IN ACCORDANCE WITH DESIGN METHOD B CONTAINED IN SECTION 14 OF THE AASHTO LRFD BRIDGE DESIGN SPECIFICATIONS. FABRICATION SHALL BE IN ACCORDANCE WITH SECTION 15 OF THE AASHTO LRFD BRIDGE CONSTRUCTION SPECIFICATIONS.
- ALL BEARINGS ARE DESIGNED FOR A LOW TEMPERATURE ZONE C AND SHALL HAVE A DUROMETER HARDNESS OF 60. METALLIC REINFORCEMENT SHALL HAVE A MINIMUM YIELD STRENGTH OF 36 KSI.
- BEARING PADS ARE DESIGNED FOR ZERO BRIDGE GRADE. FOR BRIDGE GRADES GREATER THAN 5 X, PADS SHALL BE SPECIFICALLY DESIGNED FOR THE GRADE. AS AN ALTERNATE, CAST-IN-PLACE BEVELED SOLE PLATES MAY BE USED.
- DESIGNER, FABRICATOR AND ERECTOR SHALL BE AWARE THAT SKEWED END BEAMS MAY TWIST OR WARP, CAUSING UNEVEN BEAM SEATING AT THE BEARINGS. THE CONTRACTOR IS REQUIRED TO CORRECT AT THE TIME OF ERECTION, BEFORE THE BEAMS ARE SEALED IN PLACE. METHOD OF CORRECTION SHALL PROVIDE AN EVEN TOTAL BEAM AND A LEVEL TOP BEAM SURFACE. TOLERANCE AFTER CORRECTION SHALL BE 1/8 INCH. THE FABRICATOR SHALL NOTIFY THE CONTRACTOR AND DESIGNER IF CORRECTIONS ARE REQUIRED PRIOR TO SHIPMENT.
- FOR BEAMS WITH STEPPED ENDS USE PADS AB, B2, OR CB ON BOTH SIDES OF EACH BEAM.
- ELASTOMERIC BEARING PADS SHALL BE INCLUDED IN THE PRICE OF THE BEAMS.

BOX BEAM BEARING PAD CONTROL DIMENSIONS								
PAD	LENGTH	WIDTH	HEIGHT	NO. SHIMS	SHIM SIZE	SPAN RANGES	MAXIMUM REACTION	MAXIMUM MOVEMENT ONE DIRECTION
A	28"	18"	1 1/2"	3	1/4" x 4 1/2" x 2 1/2" - 3/4"	20' - 30'	55 KIPS	0.75"
B1	48"	28"	1 1/2"	3	1/4" x 4 1/2" x 2 1/2" - 3/4"	40' - 75'	75 KIPS	0.80"
C	28"	18"	1 1/2"	3	1/4" x 4 1/2" x 2 1/2" - 3/4"	20' - 30'	55 KIPS	0.75"
B2	48"	18"	1 1/2"	3	1/4" x 4 1/2" x 2 1/2" - 3/4"	40' - 75'	38 KIPS	0.80"
D	28"	18"	1 1/2"	3	1/4" x 4 1/2" x 2 1/2" - 3/4"	20' - 30'	55 KIPS	0.75"

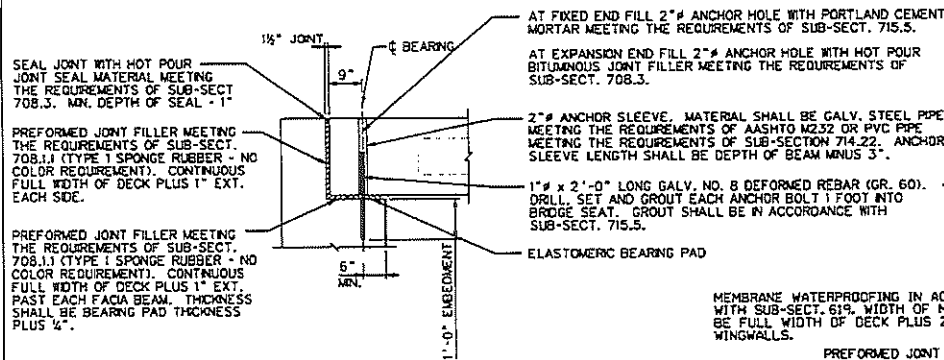

END BEARING DETAIL WITH BACKWALL

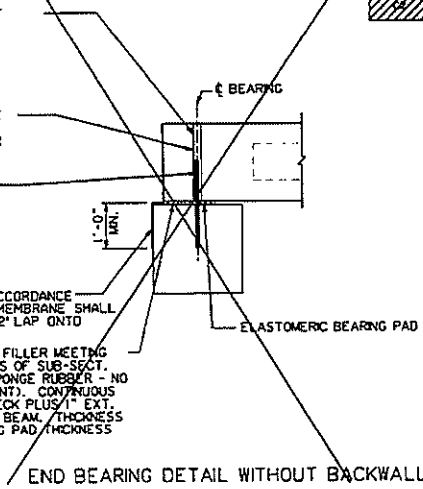

END BEARING DETAIL WITHOUT BACKWALL

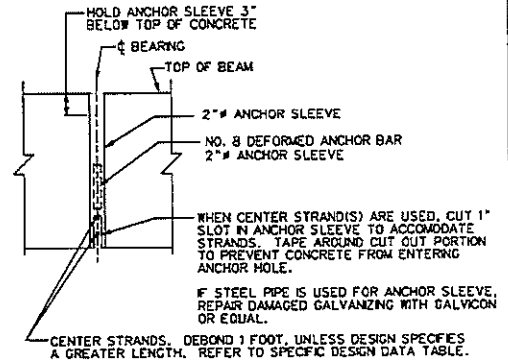

ANCHOR SLEEVE DETAIL

NOT TO SCALE

WEST VIRGINIA DEPARTMENT OF TRANSPORTATION DIVISION OF HIGHWAYS ENGINEERING DIVISION				DESIGNED CWH	DATE 12-19	CHECKED CWH	DATE 12-19	CONSTRUCTION PLANS OF HOPE STATION SUPERSTRUCTURE REPLACEMENT ON C.R. 33/22 (SLS) OVER STONECOAL CREEK LEWIS COUNTY	STANDARD BRIDGE PLANS CONCRETE ADJACENT BOX BEAM MISCELLANEOUS BEAM DETAIL 3 OF 3 SHEET NUMBER 16 OF 16 (3000MB3)
NO.	REVISION	DATE	BY	DATE	DATE	DATE	DATE		

## West Virginia Ethics Commission



### Disclosure of Interested Parties to Contracts

Pursuant to *W. Va. Code* § 6D-1-2, a state agency may not enter into a contract, or a series of related contracts, that has/have an actual or estimated value of \$1 million or more until the business entity submits to the contracting state agency a Disclosure of Interested Parties to the applicable contract. In addition, the business entity awarded a contract is obligated to submit a supplemental Disclosure of Interested Parties reflecting any new or differing interested parties to the contract within 30 days following the completion or termination of the applicable contract.

For purposes of complying with these requirements, the following definitions apply:

*"Business entity"* means any entity recognized by law through which business is conducted, including a sole proprietorship, partnership or corporation, but does not include publicly traded companies listed on a national or international stock exchange.

*"Interested party" or "Interested parties"* means:

- (1) A business entity performing work or service pursuant to, or in furtherance of, the applicable contract, including specifically sub-contractors;
- (2) the person(s) who have an ownership interest equal to or greater than 25% in the business entity performing work or service pursuant to, or in furtherance of, the applicable contract. (This subdivision does not apply to a publicly traded company); and
- (3) the person or business entity, if any, that served as a compensated broker or intermediary to actively facilitate the applicable contract or negotiated the terms of the applicable contract with the state agency. (This subdivision does not apply to persons or business entities performing legal services related to the negotiation or drafting of the applicable contract.)

*"State agency"* means a board, commission, office, department or other agency in the executive, judicial or legislative branch of state government, including publicly funded institutions of higher education: Provided, that for purposes of *W. Va. Code* § 6D-1-2, the West Virginia Investment Management Board shall not be deemed a state agency nor subject to the requirements of that provision.

The contracting business entity must complete this form and submit it to the contracting state agency prior to contract award and to complete another form within 30 days of contract completion or termination.

*This form was created by the State of West Virginia Ethics Commission, 210 Brooks Street, Suite 300, Charleston, WV 25301-1804. Telephone: (304)558-0664; fax: (304)558-2169; e-mail: [ethics@wv.gov](mailto:ethics@wv.gov); website: [www.ethics.wv.gov](http://www.ethics.wv.gov).*

West Virginia Ethics Commission  
Disclosure of Interested Parties to Contracts

(Required by W. Va. Code § 6D-1-2)

Name of Contracting Business Entity: EASTERN VAULT CO. Address: 494 Courthouse Rd  
PRINCETON WV 24740

Name of Authorized Agent: BRIAN P. STRUBLE Address: SAME

Contract Number: DOT 2000000152 Contract Description: PRESTRESSED BEAMS

Governmental agency awarding contract: WV DOW

Check here if this is a Supplemental Disclosure

List the Names of Interested Parties to the contract which are known or reasonably anticipated by the contracting business entity for each category below (attach additional pages if necessary):

- 1. Subcontractors or other entities performing work or service under the Contract  
 Check here if none, otherwise list entity/individual names below.
- 2. Any person or entity who owns 25% or more of contracting entity (not applicable to publicly traded entities)  
 Check here if none, otherwise list entity/individual names below.
- 3. Any person or entity that facilitated, or negotiated the terms of, the applicable contract (excluding legal services related to the negotiation or drafting of the applicable contract)  
 Check here if none, otherwise list entity/individual names below.

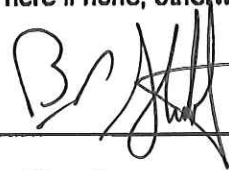
Signature:  BRIAN STRUBLE Date Signed: 4-28-20

**Notary Verification**

State of WEST VIRGINIA, County of MERCER:

I, BRIAN P. STRUBLE, the authorized agent of the contracting business entity listed above, being duly sworn, acknowledge that the Disclosure herein is being made under oath and under the penalty of perjury.

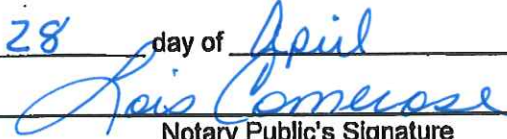
Taken, sworn to and subscribed before me this 28 day of April, 2020  
  
Notary Public's Signature

**To be completed by State Agency:**  
Date Received by State Agency: \_\_\_\_\_  
Date submitted to Ethics Commission: \_\_\_\_\_  
Governmental agency submitting Disclosure: \_\_\_\_\_



STATE OF WEST VIRGINIA  
Purchasing Division

# PURCHASING AFFIDAVIT

**CONSTRUCTION CONTRACTS:** Under W. Va. Code § 5-22-1(i), the contracting public entity shall not award a construction contract to any bidder that is known to be in default on any monetary obligation owed to the state or a political subdivision of the state, including, but not limited to, obligations related to payroll taxes, property taxes, sales and use taxes, fire service fees, or other fines or fees.

**ALL CONTRACTS:** Under W. Va. Code §5A-3-10a, no contract or renewal of any contract may be awarded by the state or any of its political subdivisions to any vendor or prospective vendor when the vendor or prospective vendor or a related party to the vendor or prospective vendor is a debtor and: (1) the debt owed is an amount greater than one thousand dollars in the aggregate; or (2) the debtor is in employer default.

**EXCEPTION:** The prohibition listed above does not apply where a vendor has contested any tax administered pursuant to chapter eleven of the W. Va. Code, workers' compensation premium, permit fee or environmental fee or assessment and the matter has not become final or where the vendor has entered into a payment plan or agreement and the vendor is not in default of any of the provisions of such plan or agreement.

**DEFINITIONS:**

"Debt" means any assessment, premium, penalty, fine, tax or other amount of money owed to the state or any of its political subdivisions because of a judgment, fine, permit violation, license assessment, defaulted workers' compensation premium, penalty or other assessment presently delinquent or due and required to be paid to the state or any of its political subdivisions, including any interest or additional penalties accrued thereon.

"Employer default" means having an outstanding balance or liability to the old fund or to the uninsured employers' fund or being in policy default, as defined in W. Va. Code § 23-2c-2, failure to maintain mandatory workers' compensation coverage, or failure to fully meet its obligations as a workers' compensation self-insured employer. An employer is not in employer default if it has entered into a repayment agreement with the Insurance Commissioner and remains in compliance with the obligations under the repayment agreement.

"Related party" means a party, whether an individual, corporation, partnership, association, limited liability company or any other form or business association or other entity whatsoever, related to any vendor by blood, marriage, ownership or contract through which the party has a relationship of ownership or other interest with the vendor so that the party will actually or by effect receive or control a portion of the benefit, profit or other consideration from performance of a vendor contract with the party receiving an amount that meets or exceeds five percent of the total contract amount.

**AFFIRMATION:** By signing this form, the vendor's authorized signer affirms and acknowledges under penalty of law for false swearing (W. Va. Code §61-5-3) that: (1) for construction contracts, the vendor is not in default on any monetary obligation owed to the state or a political subdivision of the state, and (2) for all other contracts, that neither vendor nor any related party owe a debt as defined above and that neither vendor nor any related party are in employer default as defined above, unless the debt or employer default is permitted under the exception above.

**WITNESS THE FOLLOWING SIGNATURE:**

Vendor's Name: EASTERN VAULT CO., INC.

Authorized Signature: *B.P. [Signature]* Date: \_\_\_\_\_

State of WEST VIRGINIA

County of MERCER, to-wit:

Taken, subscribed, and sworn to before me this 28<sup>th</sup> day of Apr. L, 2020.

My Commission expires March 26, 2023

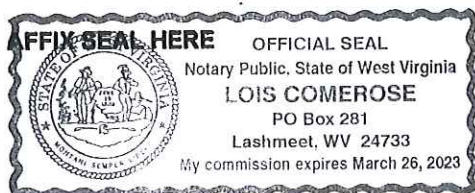

NOTARY PUBLIC *Lois Comerosé*

**CRFQ DOT20000000152**

Item Number	Quantity	Unit of Measure	Description	Unit Cost	Total Cost
1	1361	Square feet	27 inch interior box beam	\$ 49.50	\$ 67,369.50
2	454	Square feet	27 inch exterior box beam	\$ 62.80	\$ 28,511.20
3	14	Each	Elastomeric laminated bearing pads B-1	\$ 200.00	\$ 2,800.00
4	4	Each	Elastomeric laminated bearing pads B-2	\$ 175.00	\$ 700.00
5	16	Each	Swedged anchor bolt or #8 deformed rebar	\$ 10.00	\$ 160.00
6	2	Each	Sponge rubber preformed joint filler	\$ 20.00	\$ 40.00
7	4	Each	Sponge rubber preformed joint filler	\$ 30.00	\$ 120.00
8	12	Each	Sponge rubber preformed joint filler	\$ 30.00	\$ 360.00
9	16	Each	Sponge rubber preformed joint filler	\$ 30.00	\$ 480.00
10	49	Each	Sponge Rubber Washer	\$ 10.00	\$ 490.00
11	137.5	Each	Bridge Rail	\$ 100.00	\$ 13,750.00
12	14	Each	Post tension bearing plates	\$ 50.00	\$ 700.00
13	192	Linear feet	Post tension bar	\$ 18.75	\$ 3,600.00
14	4	Each	Assymetrical Thrie Beam Transition Section	\$ 225.00	\$ 900.00

**Total Bid Amount**



\$ 119,980.70