



The following documentation is an electronically-submitted vendor response to an advertised solicitation from the *West Virginia Purchasing Bulletin* within the Vendor Self-Service portal at *wvOASIS.gov*. As part of the State of West Virginia's procurement process, and to maintain the transparency of the bid-opening process, this documentation submitted online is publicly posted by the West Virginia Purchasing Division at *WVPurchasing.gov* with any other vendor responses to this solicitation submitted to the Purchasing Division in hard copy format.

Header 3

[List View](#)

General Information

Contact

Default Values

Discount

Document Information

Procurement Folder: 642516

Procurement Type: Central Master Agreement

Vendor ID: 

Legal Name: PEWAG TRACTION CHAIN INC

Alias/DBA:

Total Bid: \$0.00

Response Date: Response Time:

SO Doc Code: CRFQ

SO Dept: 0803



SO Doc ID: DOT2000000070

Published Date: 12/19/19

Close Date: 12/23/19

Close Time: 13:30

Status: Closed

Solicitation Description:  

Total of Header Attachments: 3

Total of All Attachments: 3



Purchasing Division
 2019 Washington Street East
 Post Office Box 50130
 Charleston, WV 25305-0130

**State of West Virginia
 Solicitation Response**

Proc Folder : 642516

Solicitation Description : ADDENDUM 2 TIRE AND CROSS CHAINS, COMP/ACCESS. (7020C004)

Proc Type : Central Master Agreement

Date issued	Solicitation Closes	Solicitation Response	Version
	2019-12-23 13:30:00	SR 0803 ESR12191900000003720	1

VENDOR
VS0000015040 PEWAG TRACTION CHAIN INC

Solicitation Number: CRFQ 0803 DOT2000000070

Total Bid : \$0.00 **Response Date:** 2019-12-20 **Response Time:** 15:50:05

Comments:

FOR INFORMATION CONTACT THE BUYER
 Crystal G Hustead
 (304) 558-2402
 crystal.g.hustead@wv.gov

Signature on File	FEIN #	DATE
--------------------------	---------------	-------------

All offers subject to all terms and conditions contained in this solicitation

Line	Comm Ln Desc	Qty	Unit Issue	Unit Price	Ln Total Or Contract Amount
1	TIRE AND CROSS CHAINS, COMPONENTS AND	0.00000	EA	\$0.000000	\$0.00

Comm Code	Manufacturer	Specification	Model #
31151600			

Extended Description : PRICING TO BE INCLUDED ON THE ATTACHED EXHIBIT A PRICING PAGE

VENDOR: pewag Traction Chain, Inc TIRE & CROSS CHAIN, COMPONENTS & ACCESSORIES - Pricing Page

Discount Percentage** -65.00% (Please enter as a negative. Example discount of 5% should be -5.0%)

Markup Percentage** 0.00%

Item No.	OEM Part number	"Or Equal" Parts	Estimated Unit Quantity	Unit (for calculation purposes)	Catalog Unit Price	Units Provided for Catalog Price	**Discount/Markup** Percentage	Adjusted Unit Price	Item Total Cost
1	Part No. 245/75r17 Description: Tire chain	Part No. USA 3210 SC Description: 5.6mm Square	200	1 EA	\$ 372.81	1.00	-65.00%	\$ 130.48	\$130.48
2	Part No. 14.00x24 2-link Description: Tire chain	Part No. USA 2615 S 10mm DS Description: 10 mm Square	100	1 EA	\$ 2,400.00	1.00	-65.00%	\$ 840.00	\$840.00
3	Part No. 245/70r17 Description: Tire chain	Part No. USA 3210 SC Description: 5.6mm Square	200	1 EA	\$ 372.81	1.00	-65.00%	\$ 130.48	\$130.48
4	Part No. 14.00x24 Net Description: Tire chain	Part No. 69155 Description: 10mm Square	100	1 EA	\$ 3,785.72	1.00	-65.00%	\$ 1,325.00	\$1,325.00
5	Part No. 15.5x25 loader Description: Tire chain	Part No. USA 2612 S 10mm Description: 10mm Square	200	1 EA	\$ 1,187.77	1.00	-65.00%	\$ 415.72	\$415.72
6	Part No. 11r22.5 Description: Tire chain	Part No. USA 2247 SC Description: 7mm Square	150	1 EA	\$ 393.28	1.00	-65.00%	\$ 137.65	\$137.65
7	Part No. 17.5x25 loader Description: Tire chain	Part No. USA 2624 S 10mm Description: 10mm Square	300	1 EA	\$ 1,610.00	1.00	-65.00%	\$ 563.50	\$563.50
8	Part No. 225/70r19.5 Description: Tire chain	Part No. USA 2221 SC Description: 5.6mm Square	250	1 EA	\$ 377.48	1.00	-65.00%	\$ 132.12	\$132.12

Item No.	OEM Part number	"Or Equal" Parts	Estimated Unit Quantity	Unit (for calculation purposes)	Catalog Unit Price	Units Provided for Catalog Price	**Discount/Markup** Percentage	Adjusted Unit Price	Item Total Cost
9	Part No. 245/70r19.5 ladder Description: Tire chain	Part No. USA 2228 SC Description: 5.6mm Square	250	1 EA	\$ 400.24	1.00	-65.00%	\$ 140.08	\$140.08
10	Part No. 235/75r16 Description: Tire chain	Part No. USA 2219 SC Description: 5.6mm Square	300	1 EA	\$ 362.53	1.00	-65.00%	\$ 126.89	\$126.89
11	Part No. 245/75r16 Description: Tire chain	Part No. USA 2221 SC Description: 5.6mm Square	300	1 EA	\$ 377.48	1.00	-65.00%	\$ 132.12	\$132.12
12	Part No. 14.00x24 Description: Tire chain	Part No. USA 2615 S 10mm Description: 10mm Square	100	1 EA	\$ 1,355.14	1.00	-65.00%	\$ 474.30	\$474.30
13	Part No. 14.00x24 ladder Description: Tire chain	Part No. USA 2615 S 10mm Description: 10mm Square	150	1 EA	\$ 1,355.14	1.00	-65.00%	\$ 474.30	\$474.30
14	Part No. 225/75r19.5 zigzag Description: Tire chain	Part No. USA ZZ 2228 SC Description: Zig Zag Square	150	1 EA	\$ 374.78	1.00	-65.00%	\$ 131.17	\$131.17
15	Part No. 245/75r19.5 zigzag Description: Tire chain	Part No. USA ZZ 2228 SC Description: Zig Zag Square	150	1 EA	\$ 374.78	1.00	-65.00%	\$ 131.17	\$131.17
Total Bid Amount									\$5,284.98

CONTRACT MANAGER: Tammy Knight

TELEPHONE NUMBER: 304-641-3132

FAX NUMBER: 866-472-8775

E-MAIL ADDRESS: tammyk@pewagchain.com



Effective July 1, 2019

Pewag Traction Chain Price list

Description	ITEM	UOM	LIST Price
Adjuster	103	PAIR	\$56.60
Cam Tool	204	EACH	\$9.24
Multi Tool	205	EACH	\$67.31
Cross Chain Hook	403	EACH	\$0.77
Cross Chain Hook	405	EACH	\$1.32
Cross Chain Hook	406	EACH	\$1.52
Cross Chain Hook	409	EACH	\$2.31
Cross Chain Hook	411	EACH	\$3.73
Repair Link	705	EACH	\$1.57
Repair Link	707	EACH	\$2.22
Repair Link	708	EACH	\$2.75
Repair Link	710	EACH	\$5.36
Repair Link	712	EACH	\$7.46
Side Chain	1008	FT.	\$8.30
Side Chain	1010	FT.	\$9.60
Side Chain	1012	FT.	\$21.62
pewag Cross Chain - Continuous	3003	FT.	\$4.78
pewag Cross Chain - Continuous	3004	FT.	\$5.53
pewag Cross Chain - Continuous	3005	FT.	\$7.70
pewag Cross Chain - Continuous	3007	FT.	\$9.58
pewag Cross Chain - Continuous	3008	FT.	\$11.45
pewag Cross Chain - Continuous	3010	FT.	\$19.90
pewag Cross Chain - Continuous	3012	FT.	\$29.37
Universal	3481	PAIR	\$10,848.24
Cross chain W/O Hooks	4409	EACH	\$84.58
Cross chain W/O Hooks	4451	EACH	\$39.82
Cross chain W/O Hooks	4452	EACH	\$44.69
Repair Ring	5073	EACH	\$2.87
Universal fastener	5297	EACH	\$62.73
Cross chain W/O Hooks	5837	EACH	\$24.69
Fastener	8220	EACH	\$8.52
Fastener	8230	EACH	\$13.48
Universal Links	9900	EACH	\$17.24
Universal Links	9902	EACH	\$25.09
Universal Links	9904	EACH	\$36.73
Universal Feld	10527	PAIR	\$546.23
End Hook	12013	EACH	\$8.63
Universal Feld	22532	PAIR	\$514.65
Universal Feld	22533	PAIR	\$493.19
Universal Feld	27397	PAIR	\$909.91

Universal Feld	27404	PAIR	\$1,255.69
Universal Feld	27405	PAIR	\$881.34
Erzberg Feld	29567	PAIR	\$2,041.01
Universal Feld	29575	PAIR	\$1,301.75
Universal Feld	29576	PAIR	\$1,395.20
Universal	30669	PAIR	\$21,159.59
Universal Feld	31845	PAIR	\$967.43
Cross chain W/O Hooks	33187	EACH	\$94.70
Pin Lock	35326	EACH	\$65.77
Cross chain W/O Hooks	36250	EACH	\$21.74
Cross chain W/O Hooks	37795	EACH	\$54.72
Cross chain W/O Hooks	37801	EACH	\$65.82
Universal	45657	PAIR	\$4,955.41
Cross chain W/O Hooks	51890	EACH	\$20.08
Cross chain W/O Hooks	58325	EACH	\$65.43
Cross chain W/O Hooks	58447	EACH	\$16.92
Cross chain W/O Hooks	58448	EACH	\$19.61
Erzberg Feld	58617	PAIR	\$852.62
Erzberg Feld	58618	PAIR	\$929.26
Erzberg Feld	58622	PAIR	\$890.68
Universal Feld	58623	PAIR	\$1,974.98
Universal Feld	58624	PAIR	\$480.96
Universal Feld	58700	PAIR	\$1,307.93
Universal	60197	PAIR	\$5,015.62
Universal Feld	62049	PAIR	\$958.39
Universal Feld	63783	PAIR	\$1,230.68
Universal	69112	PAIR	\$11,251.27
Universal	69119	PAIR	\$8,244.16
Universal	69120	PAIR	\$5,550.76
Universal	69121	PAIR	\$5,688.98
Universal	69122	PAIR	\$5,870.19
Universal	69123	PAIR	\$9,432.00
Universal	69124	PAIR	\$9,914.67
Universal	69125	PAIR	\$10,305.73
Erzberg	69128	PAIR	\$26,579.80
Erzberg	69129	PAIR	\$59,414.95
Erzberg	69141	PAIR	\$19,002.84
Erzberg	69142	PAIR	\$30,479.31
Erzberg	69143	PAIR	\$30,436.44
Erzberg	69144	PAIR	\$33,420.40
Erzberg	69145	PAIR	\$36,575.25
Erzberg	69149	PAIR	\$11,395.07
Universal	69150	PAIR	\$12,603.60
Universal	69155	PAIR	\$3,785.72
Universal	69156	PAIR	\$8,687.71
Universal	69157	PAIR	\$7,620.57
Universal	69158	PAIR	\$8,424.27
Universal	69159	PAIR	\$11,768.95
Universal	69160	PAIR	\$9,409.49
Universal	69161	PAIR	\$13,639.46
Universal	69162	PAIR	\$4,678.96
Universal	69163	PAIR	\$5,015.62
Universal	69164	PAIR	\$4,747.90
Universal	69175	PAIR	\$506.57

Item 4

Universal	71793	EACH	\$9.45
Universal	84849	PAIR	\$13,045.15
Erzberg	85713	PAIR	\$12,686.02
Universal Feld	85982	PAIR	\$1,790.07
Erzberg Feld	86189	PAIR	\$1,318.41
Erzberg Feld	86190	PAIR	\$1,898.62
Erzberg Feld	86194	PAIR	\$1,284.63
Erzberg	93087	PAIR	\$19,735.96
Erzberg	95122	PAIR	\$18,676.42
Erzberg repair links	01386	EACH	\$65.43
Erzberg repair links	01390	EACH	\$75.91
pewag Side Chain - Continuous	05625	EACH	\$60.19
pewag Side Chain - Continuous	1004A	FT.	\$5.11
pewag Side Chain - Continuous	1006USA	FT.	\$5.91
pewag Side Chain - Continuous	1007USA	FT.	\$6.65
pewag Side Chain - Continuous	1009A	FT.	\$7.68
pewag Side Chain - Continuous	1011A	FT.	\$17.30
pewag Side Chain - Continuous	1016USA	EACH	\$90.49
pewag Side Chain - Continuous	1017USA	EACH	\$77.17
pewag Side Chain - Continuous	1019USA	EACH	\$104.29
Universal Feld	29370F	PAIR	\$987.18
pewag cross chain - Continuous	3008TSL	FT.	\$13.37
pewag cross chain - Continuous	3010TSL	FT.	\$20.96
Universal Feld	3188F	PAIR	\$927.25
Fastener	319USA	EACH	\$7.51
Fastener	320USA	EACH	\$9.42
Fastener	407USA	EACH	\$1.84
Fastener	5835USA	EACH	\$9.96
Fastener	5927USA	EACH	\$8.56
pewag universal / Erzberg Repair S	7066TC	EACH	\$12.28
pewag universal / Erzberg Repair S	7067TC	EACH	\$18.84
pewag universal / Erzberg Repair S	7068TC	EACH	\$24.96
pewag universal / Erzberg Repair S	7084TC	EACH	\$46.62
pewag universal / Erzberg Repair S	7093TC	EACH	\$11.54
pewag universal / Erzberg Repair S	7094TC	EACH	\$17.18
Lever	8250-KST	EACH	\$24.84
Lever	8250-N	EACH	\$28.49
pewag ASV	A 01 SV	PAIR	\$2,402.41
pewag ASV	A 02 SV	PAIR	\$2,434.46
pewag ASV	A 08 SV	PAIR	\$2,946.84
pewag ASV	A 10 SV	PAIR	\$3,292.51
pewag ASV	A 155 8 SV	PAIR	\$3,837.50
pewag ASV	A 160 8 SV	PAIR	\$3,973.75
pewag ASV	A 291 SV	PAIR	\$3,231.69
pewag ASV	A 294 SV	PAIR	\$3,590.77
pewag ASV	A 297 SV	PAIR	\$4,400.37
pewag ASV	A 74 SV	PAIR	\$1,150.35
pewag ASV	A 75 SV	PAIR	\$1,174.57
pewag ASV	A 76 SV	PAIR	\$1,174.57
pewag ASV	A 77 SV	PAIR	\$1,174.57
pewag ASV	A 78 SV	PAIR	\$1,174.57
pewag ASV	A 79 SV	PAIR	\$1,319.88
pewag ASV	A 80 SV	PAIR	\$1,356.75
pewag ASV	A 81 SV	PAIR	\$1,365.40

pewag ASV	A 81A SV	PAIR	\$1,365.40
pewag ASV	A 82 SV	PAIR	\$1,451.81
pewag ASV	A 83 SV	PAIR	\$1,460.46
pewag ASV	A 84 SV	PAIR	\$1,469.10
pewag ASV	A 85 SV	PAIR	\$1,581.44
pewag ASV	A 86 SV	PAIR	\$1,692.14
pewag ASV	A 87 SV	PAIR	\$1,750.35
pewag ASV	A 88 SV	PAIR	\$1,667.86
pewag ASV	A 89 SV	PAIR	\$1,834.65
pewag ASV	A 90 SV	PAIR	\$1,853.18
pewag ASV	A 91 SV	PAIR	\$1,955.79
pewag ASV	A 93 8 SV	PAIR	\$1,985.13
pewag ASV	A 93 SV	PAIR	\$1,975.20
pewag ASV	A 94 5 SV	PAIR	\$1,114.79
pewag ASV	A 94 SV	PAIR	\$2,229.57
pewag ASV	A 95 SV	PAIR	\$2,315.99
pewag ASV	A 97 SV	PAIR	\$2,315.99
pewag cervino	CL 01 R	PAIR	\$844.40
pewag cervino	CL 02 R	PAIR	\$858.93
pewag cervino	CL 05 R	PAIR	\$949.34
pewag cervino	CL 08 R	PAIR	\$1,007.47
pewag cervino	CL 160 7 R	PAIR	\$1,101.11
pewag cervino	CL 201 R	PAIR	\$1,601.61
pewag cervino	CL 294 R	PAIR	\$1,393.34
pewag cervino	CL 297 R	PAIR	\$1,456.30
pewag cervino	CL 87 R	PAIR	\$600.60
pewag cervino	CL 89 R	PAIR	\$737.84
pewag cervino	CL 91 R	PAIR	\$768.52
pewag cervino	CL 93 7 R	PAIR	\$776.59
pewag cervino	CL 93 R	PAIR	\$768.52
pewag cervino	CL 94 R	PAIR	\$776.59
pewag cervino	CL 95 R	PAIR	\$808.88
pewag cervino	CL 97 R	PAIR	\$808.88
pewag servo	RS 60	PAIR	\$212.02
pewag servo	RS 62	PAIR	\$212.02
pewag servo	RS 64	PAIR	\$212.02
pewag servo	RS 67	PAIR	\$212.02
pewag servo	RS 68	PAIR	\$212.02
pewag servo	RS 69	PAIR	\$212.02
pewag servo	RS 73	PAIR	\$212.02
pewag servo	RS 74	PAIR	\$212.02
pewag servo	RS 75	PAIR	\$241.88
pewag servo	RS 76	PAIR	\$241.88
pewag servo	RS 77	PAIR	\$241.88
pewag servo	RS 79	PAIR	\$241.88
pewag servo	RS 80	PAIR	\$250.84
pewag servo suv	RSV 62	PAIR	\$269.61
pewag servo suv	RSV 64	PAIR	\$269.61
pewag servo suv	RSV 67	PAIR	\$269.61
pewag servo suv	RSV 68	PAIR	\$269.61
pewag servo suv	RSV 69	PAIR	\$269.61
pewag servo suv	RSV 73	PAIR	\$269.61
pewag servo suv	RSV 74	PAIR	\$269.61
pewag servo suv	RSV 75	PAIR	\$310.56

pewag servo suv	RSV 76	PAIR	\$310.56
pewag servo suv	RSV 77	PAIR	\$310.56
pewag servo suv	RSV 79	PAIR	\$310.56
pewag servo suv	RSV 80	PAIR	\$344.69
pewag servo suv	RSV 80A	PAIR	\$344.69
pewag servo suv	RSV 81	PAIR	\$344.69
pewag servo suv	RSV 81A	PAIR	\$344.69
pewag servo suv	RSV 82	PAIR	\$344.69
pewag snox pro	SXP 500	PAIR	\$230.75
pewag snox pro	SXP 505	PAIR	\$230.75
pewag snox pro	SXP 510	PAIR	\$230.75
pewag snox pro	SXP 520	PAIR	\$264.68
pewag snox pro	SXP 530	PAIR	\$264.68
pewag snox pro	SXP 540	PAIR	\$264.68
pewag snox pro	SXP 550	PAIR	\$303.70
pewag snox pro	SXP 560	PAIR	\$303.70
pewag snox pro	SXP 570	PAIR	\$303.70
pewag snox pro	SXV 570	PAIR	\$348.76
pewag snox pro	SXV 580	PAIR	\$348.76
pewag snox pro	SXV 590	PAIR	\$382.30
pewag snox pro	SXV 600	PAIR	\$382.30
pewag tite-n-lite	TNL 2245 SC	PAIR	\$838.88
pewag tite-n-lite	TNL 2249 SC	PAIR	\$910.11
pewag tite-n-lite	TNL 4245 SC	PAIR	\$1,593.91
pewag tite-n-lite	TNL 4249 SC	PAIR	\$1,729.27
pewag CL-PSC	USA 01 PSC	PAIR	\$611.09
pewag CL-PSC	USA 02 PSC	PAIR	\$620.39
pewag Tractor Chains	USA0822 S 8.2mm	PAIR	\$689.41
pewag Tractor Chains	USA 0829 S 8.2mm	PAIR	\$580.58
pewag Tractor Chains	USA 0831 S 8.2mm	PAIR	\$708.76
pewag Tractor Chains	USA 0832 S 8.2mm	PAIR	\$749.44
pewag Tractor Chains	USA 0834 S 8.2mm	PAIR	\$750.44
pewag Tractor Chains	USA 0836 S 8.2mm	PAIR	\$833.01
pewag Tractor Chains	USA 0838 S 8.2mm	PAIR	\$959.79
pewag Tractor Chains	USA 0846 S 8.2mm	PAIR	\$1,154.27
pewag Tractor Chains	USA 0850 S 10mm	PAIR	\$1,016.12
pewag Tractor Chains	USA 0850 S 8.2mm	PAIR	\$761.91
pewag Tractor Chains	USA 0852 S 10mm	PAIR	\$1,225.41
pewag Tractor Chains	USA 0852 S 8.2mm	PAIR	\$900.00
pewag Tractor Chains	USA 0856 S 10mm	PAIR	\$1,399.02
pewag Tractor Chains	USA 0856 S 8.2mm	PAIR	\$1,023.41
pewag Tractor Chains	USA 0858 S 10mm	PAIR	\$1,427.44
pewag Tractor Chains	USA 0858 S 8.2mm	PAIR	\$1,035.17
pewag Tractor Chains	USA 0859 S 10mm	PAIR	\$1,846.68
pewag Tractor Chains	USA 0859 S 8.2mm	PAIR	\$1,314.36
pewag Tractor Chains	USA 0862 S 10mm	PAIR	\$1,641.58
pewag Tractor Chains	USA 0862 S 8.2mm	PAIR	\$1,221.51
pewag Tractor Chains	USA 0866 S 10mm	PAIR	\$2,493.43
pewag Tractor Chains	USA 0866 S 8.2mm	PAIR	\$1,902.04
pewag Tractor Chains	USA 0869 S 10mm	PAIR	\$2,119.21
pewag Tractor Chains	USA 0869 S 8.2mm	PAIR	\$1,616.59
pewag Tractor Chains	USA 0871 S 10mm	PAIR	\$2,624.94
pewag Tractor Chains	USA 0871 S 8.2mm	PAIR	\$2,002.35
pewag Tractor Chains	USA 0874 S 10mm	PAIR	\$2,224.19

pewag Tractor Chains	USA 0874 S 8.2mm	PAIR	\$1,696.68	
pewag Tractor Chains	USA 0876 S 10mm	PAIR	\$2,370.64	
pewag Tractor Chains	USA 0876 S 8.2mm	PAIR	\$1,808.40	
pewag Tractor Chains	USA 0877 S 10mm	PAIR	\$2,507.95	
pewag Tractor Chains	USA 0877 S 8.2mm	PAIR	\$1,913.10	
pewag Tractor Chains	USA 0879 S 10mm	PAIR	\$2,654.51	
pewag Tractor Chains	USA 0879 S 8.2mm	PAIR	\$2,024.90	
pewag Tractor Chains	USA 0881 S 10mm	PAIR	\$1,430.53	
pewag Tractor Chains	USA 0881 S 12mm	PAIR	\$1,999.22	
pewag Tractor Chains	USA 0882 S 10mm	PAIR	\$1,682.96	
pewag Tractor Chains	USA 0882 S 12mm	PAIR	\$2,206.23	
pewag Tractor Chains	USA 0883 S 10mm	PAIR	\$1,956.00	
pewag Tractor Chains	USA 0883 S 12mm	PAIR	\$2,421.33	
pewag Tractor Chains	USA 0884 S 10mm	PAIR	\$1,920.09	
pewag Tractor Chains	USA 0884 S 12mm	PAIR	\$2,516.34	
pewag Tractor Chains	USA 0885 S 10mm	PAIR	\$2,280.89	
pewag Tractor Chains	USA 0885 S 12mm	PAIR	\$2,888.65	
pewag Tractor Chains	USA 0887 S 10mm	PAIR	\$2,176.45	
pewag Tractor Chains	USA 0887 S 12mm	PAIR	\$2,857.84	
pewag Tractor Chains	USA 0889 S 10mm	PAIR	\$2,601.53	
pewag Tractor Chains	USA 0889 S 12mm	PAIR	\$3,289.05	
pewag Tractor Chains	USA 0890 S 10mm	PAIR	\$3,131.75	
pewag Tractor Chains	USA 0890 S 12mm	PAIR	\$3,961.17	
pewag Tractor Chains	USA 0891 S 10mm	PAIR	\$2,416.74	
pewag Tractor Chains	USA 0891 S 12mm	PAIR	\$3,060.25	
pewag Tractor Chains	USA 0892 S 10mm	PAIR	\$2,752.80	
pewag Tractor Chains	USA 0892 S 12mm	PAIR	\$3,482.11	
pewag Tractor Chains	USA 0893 S 10mm	PAIR	\$2,745.65	
pewag Tractor Chains	USA 0893 S 12mm	PAIR	\$3,474.96	
pewag Tractor Chains	USA 0894 S 10mm	PAIR	\$2,886.22	
pewag Tractor Chains	USA 0894 S 12mm	PAIR	\$3,783.61	
pewag Tractor Chains	USA 0895 S 10mm	PAIR	\$3,739.51	
pewag Tractor Chains	USA 0895 S 12mm	PAIR	\$4,733.38	
pewag CL-PSC	USA 155 PSC	PAIR	\$757.64	
pewag CL-PSC	USA 160 7 PSC	PAIR	\$772.15	
pewag CL-PSC	USA 162 PSC	PAIR	\$727.70	
pewag LT Ladder - Singles	USA2209 S	PAIR	\$321.62	
pewag LT Ladder - Singles	USA 2209 SC	PAIR	\$321.62	
pewag LT Ladder - Singles	USA 2211 S	PAIR	\$363.11	
pewag LT Ladder - Singles	USA 2211 SC	PAIR	\$363.11	
pewag LT Ladder - Singles	USA 2214 S	PAIR	\$401.85	
pewag LT Ladder - Singles	USA 2214 SC	PAIR	\$401.85	
pewag LT Ladder - Singles	USA 2216 S	PAIR	\$347.61	
pewag LT Ladder - Singles	USA 2216 SC	PAIR	\$347.61	
pewag LT Ladder - Singles	USA 2219 S	PAIR	\$362.53	
pewag LT Ladder - Singles	USA 2219 SC	PAIR	\$362.53	Item 10
pewag LT Ladder - Singles	USA 2219 SC 7ST	PAIR	\$490.54	
pewag LT Ladder - Singles	USA 2221 S	PAIR	\$377.48	
pewag LT Ladder - Singles	USA 2221 SC	PAIR	\$377.48	Items 8, 11
pewag LT Ladder - Singles	USA 2221 SC 7ST	PAIR	\$516.35	
pewag LT Ladder - Singles	USA 2226 S	PAIR	\$431.94	
pewag LT Ladder - Singles	USA 2226 SC	PAIR	\$431.94	
pewag LT Ladder - Singles	USA 2228 S	PAIR	\$400.24	
pewag LT Ladder - Singles	USA 2228 SC	PAIR	\$400.24	Item 9

pewag LT Ladder - Singles	USA 2228 SC 7ST	PAIR	\$543.55
pewag LT Ladder - Singles	USA 2229 S	PAIR	\$357.05
pewag LT Ladder - Singles	USA 2229 SC	PAIR	\$357.05
pewag HT Ladder - Singles	USA2233 S	PAIR	\$334.68
pewag HT Ladder - Singles	USA 2233 SC	PAIR	\$334.68
pewag HT Ladder - Singles	USA 2237 S	PAIR	\$364.94
pewag HT Ladder - Singles	USA 2237 SC	PAIR	\$364.94
pewag HT Ladder - Singles	USA 2238 S	PAIR	\$388.77
pewag HT Ladder - Singles	USA 2238 SC	PAIR	\$388.77
pewag HT Ladder - Singles	USA 2239 S	PAIR	\$390.19
pewag HT Ladder - Singles	USA 2239 SC	PAIR	\$390.19
pewag HT Ladder - Singles	USA 2241 S	PAIR	\$400.65
pewag HT Ladder - Singles	USA 2241 SC	PAIR	\$400.65
pewag HT Ladder - Singles	USA 2245 S	PAIR	\$410.31
pewag HT Ladder - Singles	USA 2245 SC	PAIR	\$410.31
pewag HT Ladder - Singles	USA 2247 S	PAIR	\$393.28
pewag HT Ladder - Singles	USA 2247 S 7ST	PAIR	\$545.03
pewag HT Ladder - Singles	USA 2247 S 8ST	PAIR	\$712.37
pewag HT Ladder - Singles	USA 2247 SC	PAIR	\$393.28
pewag HT Ladder - Singles	USA 2247 SC 7ST	PAIR	\$583.20
pewag HT Ladder - Singles	USA 2247 SC 8ST	PAIR	\$772.59
pewag HT Ladder - Singles	USA 2249 S	PAIR	\$420.16
pewag HT Ladder - Singles	USA 2249 S 7ST	PAIR	\$621.53
pewag HT Ladder - Singles	USA 2249 S 8ST	PAIR	\$741.05
pewag HT Ladder - Singles	USA 2249 SC	PAIR	\$420.16
pewag HT Ladder - Singles	USA 2249 SC 7ST	PAIR	\$664.09
pewag HT Ladder - Singles	USA 2249 SC 8ST	PAIR	\$802.81
pewag HT Ladder - Singles	USA 2251 S	PAIR	\$420.16
pewag HT Ladder - Singles	USA 2251 SC	PAIR	\$420.16
pewag HT Ladder - Singles	USA 2253 S	PAIR	\$585.65
pewag HT Ladder - Singles	USA 2253 SC	PAIR	\$585.65
pewag HT Ladder - Singles	USA 2255 S	PAIR	\$559.11
pewag HT Ladder - Singles	USA 2255 S 7ST	PAIR	\$731.21
pewag HT Ladder - Singles	USA 2255 SC	PAIR	\$559.11
pewag HT Ladder - Singles	USA 2255 SC 7ST	PAIR	\$781.28
pewag HT Ladder - Singles	USA 2257 S	PAIR	\$605.70
pewag HT Ladder - Singles	USA 2257 SC	PAIR	\$605.70
pewag HT Ladder - Singles	USA 2271 S	PAIR	\$781.28
pewag HT Ladder - Singles	USA 2271 SC	PAIR	\$781.28
pewag HT Ladder - Singles	USA 2273 S	PAIR	\$816.59
pewag HT Ladder - Singles	USA 2273 SC	PAIR	\$816.59
pewag Mud Service - Singles	USA2433 S	PAIR	\$486.02
pewag Mud Service - Singles	USA 2435 S	PAIR	\$506.88
pewag Mud Service - Singles	USA 2437 S	PAIR	\$527.78
pewag Mud Service - Singles	USA 2439 S	PAIR	\$559.58
pewag Mud Service - Singles	USA 2441 S	PAIR	\$682.62
pewag Mud Service - Singles	USA 2445 S	PAIR	\$712.00
pewag Mud Service - Singles	USA 2448 S	PAIR	\$747.78
pewag Mud Service - Singles	USA 2448 SC	PAIR	\$747.78
pewag Mud Service - Singles	USA 2452 S	PAIR	\$779.95
pewag Mud Service - Singles	USA 2452 SC	PAIR	\$779.95
pewag Mud Service - Singles	USA 2486 S	PAIR	\$957.34
pewag Heavy Equip. Chains	USA2612 S 8.2MM	PAIR	\$1,022.15
pewag heavy Equip. Chains	USA 2612 S 10mm	PAIR	\$1,187.77

Item 6

Item 5

pewag Heavy Equip. Chains	USA 2612 S 10mm DS	PAIR	\$2,863.40	
pewag Heavy Equip. Chains	USA 2612 S 12mm	PAIR	\$2,100.84	
pewag Heavy Equip. Chains	USA 2612 S 12mm DS	PAIR	\$3,991.59	
pewag Heavy Equip. Chains	USA 2612 S 8.2mm	PAIR	\$1,022.15	
pewag Heavy Equip. Chains	USA 2612 S 8.2mm DS	PAIR	\$1,942.09	
pewag Heavy Equip. Chains	USA 2615 S 10mm	PAIR	\$1,355.14	Items 12,13
pewag Heavy Equip. Chains	USA 2615 S 10mm DS	PAIR	\$2,400.00	Item 2
pewag Heavy Equip. Chains	USA 2615 S 12mm	PAIR	\$2,349.73	
pewag Heavy Equip. Chains	USA 2615 S 12mm DS	PAIR	\$4,464.48	
pewag Heavy Equip. Chains	USA 2615 S 8.2mm	PAIR	\$1,149.05	
pewag Heavy Equip. Chains	USA 2615 S 8.2mm DS	PAIR	\$2,183.19	
pewag Heavy Equip. Chains	USA 2624 S 10mm	PAIR	\$1,610.00	Item 7
pewag Heavy Equip. Chains	USA 2624 S 10mm DS	PAIR	\$3,295.37	
pewag Heavy Equip. Chains	USA 2624 S 12mm	PAIR	\$2,407.09	
pewag Heavy Equip. Chains	USA 2624 S 12mm DS	PAIR	\$4,573.47	
pewag Heavy Equip. Chains	USA 2627 S 10mm	PAIR	\$1,981.50	
pewag Heavy Equip. Chains	USA 2627 S 10mm DS	PAIR	\$3,764.85	
pewag Heavy Equip. Chains	USA 2627 S 12mm	PAIR	\$3,123.51	
pewag Heavy Equip. Chains	USA 2627 S 12mm DS	PAIR	\$5,934.67	
pewag Heavy Equip. Chains	USA 2633 S 10mm	PAIR	\$2,108.67	
pewag Heavy Equip. Chains	USA 2633 S 10mm DS	PAIR	\$4,006.48	
pewag Heavy Equip. Chains	USA 2633 S 12mm	PAIR	\$3,203.19	
pewag Heavy Equip. Chains	USA 2633 S 12mm DS	PAIR	\$6,086.06	
pewag Heavy Equip. Chains	USA 2636 S 10mm	PAIR	\$2,230.02	
pewag Heavy Equip. Chains	USA 2636 S 10mm DS	PAIR	\$4,237.04	
pewag Heavy Equip. Chains	USA 2636 S 12mm	PAIR	\$3,371.78	
pewag Heavy Equip. Chains	USA 2636 S 12mm DS	PAIR	\$6,406.38	
pewag Heavy Equip. Chains	USA 2642 S 10mm	PAIR	\$2,800.40	
pewag Heavy Equip. Chains	USA 2642 S 10mm DS	PAIR	\$5,320.75	
pewag Heavy Equip. Chains	USA 2642 S 12mm	PAIR	\$3,837.33	
pewag Heavy Equip. Chains	USA 2642 S 12mm DS	PAIR	\$7,290.92	
pewag Heavy Equip. Chains	USA 2645 S 10mm	PAIR	\$3,003.17	
pewag Heavy Equip. Chains	USA 2645 S 10mm DS	PAIR	\$5,706.03	
pewag Heavy Equip. Chains	USA 2645 S 12mm	PAIR	\$3,969.70	
pewag Heavy Equip. Chains	USA 2645 S 12mm DS	PAIR	\$7,542.43	
pewag Heavy Equip. Chains	USA 2648 S 10mm	PAIR	\$3,052.94	
pewag Heavy Equip. Chains	USA 2648 S 10mm DS	PAIR	\$5,800.58	
pewag Heavy Equip. Chains	USA 2648 S 12mm	PAIR	\$3,764.49	
pewag Heavy Equip. Chains	USA 2648 S 12mm DS	PAIR	\$7,152.53	
pewag Heavy Equip. Chains	USA 2654 S 10mm	PAIR	\$3,594.15	
pewag Heavy Equip. Chains	USA 2654 S 10mm DS	PAIR	\$6,828.89	
pewag Heavy Equip. Chains	USA 2654 S 12mm	PAIR	\$4,014.04	
pewag Heavy Equip. Chains	USA 2654 S 12mm DS	PAIR	\$7,626.68	
pewag Heavy Equip. Chains	USA 2657 S 10mm	PAIR	\$3,153.13	
pewag Heavy Equip. Chains	USA 2657 S 10mm DS	PAIR	\$5,990.95	
pewag Heavy Equip. Chains	USA 2657 S 12mm	PAIR	\$4,979.55	
pewag Heavy Equip. Chains	USA 2657 S 12mm DS	PAIR	\$9,461.15	
pewag Heavy Equip. Chains	USA 2660 S 10mm	PAIR	\$3,616.10	
pewag Heavy Equip. Chains	USA 2660 S 10mm DS	PAIR	\$6,870.58	
pewag Heavy Equip. Chains	USA 2660 S 12mm	PAIR	\$4,699.77	
pewag Heavy Equip. Chains	USA 2660 S 12mm DS	PAIR	\$8,929.57	
pewag Heavy Equip. Chains	USA 2672 S 10mm	PAIR	\$3,679.85	
pewag Heavy Equip. Chains	USA 2672 S 10mm DS	PAIR	\$6,991.71	
pewag Heavy Equip. Chains	USA 2672 S 12mm	PAIR	\$5,520.53	

pewag Heavy Equip. Chains	USA 2672 S 12mm DS	PAIR	\$10,489.01
pewag Heavy Equip. Chains	USA 2675 S 10mm	PAIR	\$3,895.46
pewag Heavy Equip. Chains	USA 2675 S 10mm DS	PAIR	\$7,401.38
pewag Heavy Equip. Chains	USA 2675 S 12mm	PAIR	\$5,842.47
pewag Heavy Equip. Chains	USA 2675 S 12mm DS	PAIR	\$11,100.70
pewag Wide Base	USA 3210 S	PAIR	\$372.81
pewag Wide Base	USA 3210 SC	PAIR	\$372.81
pewag Wide Base	USA 3226 S	Pair	\$362.53
pewag Wide Base	USA 3226 SC	Pair	\$362.53
pewag Wide Base	USA 3227 S	PAIR	\$371.20
pewag Wide Base	USA 3227 SC	PAIR	\$371.20
pewag Wide Base	USA 3227 SC 7ST	PAIR	\$483.75
pewag Wide Base	USA 3229 S	PAIR	\$396.64
pewag Wide Base	USA 3229 SC	PAIR	\$396.64
pewag Wide Base	USA 3229 SC 7ST	PAIR	\$483.78
pewag Wide Base	USA 3231 S	PAIR	\$434.17
pewag Wide Base	USA 3231 SC	PAIR	\$434.17
pewag Wide Base	USA 3231 SC 7ST	PAIR	\$549.43
pewag Wide Base	USA 3235 S	PAIR	\$471.22
pewag Wide Base	USA 3235 SC	PAIR	\$471.22
pewag Wide Base	USA 3235 SC 7ST	PAIR	\$583.51
pewag Wide Base	USA 3237 S	PAIR	\$509.60
pewag Wide Base	USA 3237 SC	PAIR	\$509.60
pewag Wide Base	USA 3249 S	PAIR	\$522.30
pewag Wide Base	USA 3249 SC	PAIR	\$522.30
pewag Wide Base	USA 3251 S	PAIR	\$551.06
pewag Wide Base	USA 3251 SC	PAIR	\$551.06
pewag Wide Base	USA 3255 S	PAIR	\$602.54
pewag Wide Base	USA 3255 S 8ST	PAIR	\$892.52
pewag Wide Base	USA 3255 S 8ST DS	PAIR	\$1,286.15
pewag Wide Base	USA 3255 SC	PAIR	\$602.54
pewag Wide Base	USA 3255 SC 8ST	PAIR	\$939.49
pewag Wide Base	USA 3257 S	PAIR	\$643.69
pewag Wide Base	USA 3257 SC	PAIR	\$643.69
pewag Wide Base	USA 3259 S	PAIR	\$502.14
pewag Wide Base	USA 3259 SC	PAIR	\$502.14
pewag Wide Base	USA 3261 S	PAIR	\$724.13
pewag Wide Base	USA 3261 S 8ST	PAIR	\$874.18
pewag Wide Base	USA 3261 S 8ST DS	PAIR	\$1,296.20
pewag Wide Base	USA 3261 SC	PAIR	\$724.13
pewag Wide Base	USA 3265 S	PAIR	\$548.65
pewag Wide Base	USA 3265 SC	PAIR	\$548.65
pewag Wide Base	USA 3267 S	PAIR	\$562.67
pewag Wide Base	USA 3267 SC	PAIR	\$562.67
pewag Wide Base	USA 3269 S	PAIR	\$609.45
pewag Wide Base	USA 3269 SC	PAIR	\$609.45
pewag Wide Base	USA 3271 S	PAIR	\$710.93
pewag Wide Base	USA 3271 S 8ST	PAIR	\$880.67
pewag Wide Base	USA 3271 S 8ST DS	PAIR	\$1,451.94
pewag Wide Base	USA 3271 SC	PAIR	\$710.93
pewag Wide Base	USA 3271 SC 8ST	PAIR	\$978.53
pewag Wide Base	USA 3273 S	PAIR	\$655.09
pewag Wide Base	USA 3273 SC	PAIR	\$655.09
pewag Wide Base	USA 3275 S	PAIR	\$731.12

Items 1, 3

pewag Wide Base	USA 3275 SC	PAIR	\$731.12
pewag Wide Base	USA 3277 S	PAIR	\$894.51
pewag Wide Base	USA 3277 SC	PAIR	\$894.51
pewag LT Ladder - Duals	USA 4211 S	PAIR	\$718.95
pewag LT Ladder - Duals	USA 4211 SC	PAIR	\$718.95
pewag LT Ladder - Duals	USA 4214 S	PAIR	\$795.66
pewag LT Ladder - Duals	USA 4214 SC	PAIR	\$795.66
pewag LT Ladder - Duals	USA 4216 S	PAIR	\$688.26
pewag LT Ladder - Duals	USA 4216 SC	PAIR	\$688.26
pewag LT Ladder - Duals	USA 4219 S	PAIR	\$717.82
pewag LT Ladder - Duals	USA 4219 SC	PAIR	\$717.82
pewag LT Ladder - Duals	USA 4221 S	PAIR	\$747.41
pewag LT Ladder - Duals	USA 4221 SC	PAIR	\$747.41
pewag LT Ladder - Duals	USA 4221 SC 7ST	PAIR	\$914.55
pewag LT Ladder - Duals	USA 4226 S	PAIR	\$831.59
pewag LT Ladder - Duals	USA 4226 SC	PAIR	\$855.24
pewag LT Ladder - Duals	USA 4228 S	PAIR	\$792.47
pewag LT Ladder - Duals	USA 4228 SC	PAIR	\$792.47
pewag LT Ladder - Duals	USA 4228 SC 7ST	PAIR	\$962.68
pewag LT Ladder - Duals	USA 4229 S	PAIR	\$706.95
pewag LT Ladder - Duals	USA 4229 SC	PAIR	\$706.95
pewag HT Ladder - Duals	USA4233 S	PAIR	\$722.58
pewag HT Ladder - Duals	USA 4233 SC	PAIR	\$722.58
pewag HT Ladder - Duals	USA 4237 S	PAIR	\$736.29
pewag HT Ladder - Duals	USA 4237 SC	PAIR	\$736.29
pewag HT Ladder - Duals	USA 4238 S	PAIR	\$742.27
pewag HT Ladder - Duals	USA 4238 SC	PAIR	\$742.27
pewag HT Ladder - Duals	USA 4239 S	PAIR	\$748.23
pewag HT Ladder - Duals	USA 4239 SC	PAIR	\$748.23
pewag HT Ladder - Duals	USA 4241 S	PAIR	\$793.29
pewag HT Ladder - Duals	USA 4241 SC	PAIR	\$793.29
pewag HT Ladder - Duals	USA 4245 S	PAIR	\$812.41
pewag HT Ladder - Duals	USA 4245 SC	PAIR	\$812.41
pewag HT Ladder - Duals	USA 4247 S	PAIR	\$819.67
pewag HT Ladder - Duals	USA 4247 S 7ST	PAIR	\$1,037.47
pewag HT Ladder - Duals	USA 4247 S 8ST	PAIR	\$1,152.75
pewag HT Ladder - Duals	USA 4247 SC	PAIR	\$819.67
pewag HT Ladder - Duals	USA 4247 SC 7ST	PAIR	\$1,106.83
pewag HT Ladder - Duals	USA 4247 SC 8ST	PAIR	\$1,229.81
pewag HT Ladder - Duals	USA 4249 S	PAIR	\$881.59
pewag HT Ladder - Duals	USA 4249 S 7ST	PAIR	\$1,104.41
pewag HT Ladder - Duals	USA 4249 S 8ST	PAIR	\$1,227.12
pewag HT Ladder - Duals	USA 4249 SC	PAIR	\$881.59
pewag HT Ladder - Duals	USA 4249 SC 7ST	PAIR	\$1,179.20
pewag HT Ladder - Duals	USA 4249 SC 8ST	PAIR	\$1,310.22
pewag HT Ladder - Duals	USA 4251 S	PAIR	\$888.83
pewag HT Ladder - Duals	USA 4251 SC	PAIR	\$888.83
pewag HT Ladder - Duals	USA 4253 S	PAIR	\$1,212.29
pewag HT Ladder - Duals	USA 4253 SC	PAIR	\$1,212.29
pewag HT Ladder - Duals	USA 4255 S	PAIR	\$1,013.67
pewag HT Ladder - Duals	USA 4255 S 7ST	PAIR	\$1,162.54
pewag HT Ladder - Duals	USA 4255 SC	PAIR	\$1,013.67
pewag HT Ladder - Duals	USA 4255 SC 7ST	PAIR	\$1,215.67
pewag HT Ladder - Duals	USA 4257 S	PAIR	\$1,199.29

pewag HT Ladder - Duals	USA 4257 SC	PAIR	\$1,199.29
pewag HT Ladder - Duals	USA 4271 S	PAIR	\$1,546.93
pewag HT Ladder - Duals	USA 4271 SC	PAIR	\$1,546.93
pewag HT Ladder - Duals	USA 4273 S	PAIR	\$1,616.86
pewag HT Ladder - Duals	USA 4273 SC	PAIR	\$1,616.86
pewag mud service Duals	USA4412 S	PAIR	\$1,008.21
pewag mud service Duals	USA 4435 S	PAIR	\$1,216.33
pewag mud service Duals	USA 4437 S	PAIR	\$1,285.45
pewag mud service Duals	USA 4448 S	PAIR	\$1,340.73
pewag mud service Duals	USA 4448 SC	PAIR	\$1,340.73
pewag mud service Duals	USA 4461 S	PAIR	\$1,370.23
pewag mud service Duals	USA 4461 SC	PAIR	\$1,370.23
pewag mud service Duals	USA 4486 S	PAIR	\$1,686.81
pewag Cross Chains with Hooks	USA 6219	EACH	\$10.23
pewag Cross Chains with Hooks	USA 6221	EACH	\$11.48
pewag Cross Chains with Hooks	USA 6225	EACH	\$12.74
pewag Cross Chains with Hooks	USA 6229	EACH	\$14.00
pewag Cross Chains with Hooks	USA 6251	EACH	\$14.13
pewag Cross Chains with Hooks	USA 6251 7ST	EACH	\$22.24
pewag Cross Chains with Hooks	USA 6251 8ST	EACH	\$35.27
pewag Cross Chains with Hooks	USA 6253	EACH	\$15.84
pewag Cross Chains with Hooks	USA 6253 7ST	EACH	\$24.26
pewag Cross Chains with Hooks	USA 6253 8ST	EACH	\$38.48
pewag Cross Chains with Hooks	USA 6256 8.2mm	EACH	\$16.72
pewag Cross Chains with Hooks	USA 6259	EACH	\$17.55
pewag Cross Chains with Hooks	USA 6260	EACH	\$15.84
pewag Cross Chains with Hooks	USA 6263	EACH	\$17.55
pewag Cross Chains with Hooks	USA 6263 7ST	EACH	\$26.28
pewag Cross Chains with Hooks	USA 6263 8ST	EACH	\$41.69
pewag Cross Chains with Hooks	USA 6265	EACH	\$17.55
pewag Cross Chains with Hooks	USA 6266	EACH	\$19.25
pewag Cross Chains with Hooks	USA 6266 7ST	EACH	\$28.31
pewag Cross Chains with Hooks	USA 6266 8.2mm	EACH	\$24.33
pewag Cross Chains with Hooks	USA 6266 8ST	EACH	\$44.89
pewag Cross Chains with Hooks	USA 6267 7mm	EACH	\$28.81
pewag Cross Chains with Hooks	USA 6434 8.2mm	EACH	\$21.79
pewag Cross Chains with Hooks	USA 6445 8.2mm	EACH	\$24.33
pewag Cross Chains with Hooks	USA 6630 10mm	EACH	\$47.72
pewag Cross Chains with Hooks	USA 6630 12mm	EACH	\$67.23
pewag Cross Chains with Hooks	USA 6630 8.2mm	EACH	\$29.39
pewag Cross Chains with Hooks	USA 6640 10mm	EACH	\$52.64
pewag Cross Chains with Hooks	USA 6640 12mm	EACH	\$76.97
pewag Cross Chains with Hooks	USA 6650 10mm	EACH	\$62.49
pewag Cross Chains with Hooks	USA 6650 12mm	EACH	\$96.46
pewag Cross Chains with Hooks	USA 6660 10mm	EACH	\$72.33
pewag Cross Chains with Hooks	USA 6660 12mm	EACH	\$106.20
pewag Cross Chains with Hooks	USA 6670 10mm	EACH	\$82.18
pewag Cross Chains with Hooks	USA 6670 12mm	EACH	\$125.68
pewag Cross Chains with Hooks	USA 6680 10mm	EACH	\$92.02
pewag Cross Chains with Hooks	USA 6680 12mm	EACH	\$145.17
pewag Cross Chains with Hooks	USA 7213	EACH	\$19.25
pewag Cross Chains with Hooks	USA 7213 8ST	EACH	\$48.10
pewag Cross Chains with Hooks	USA 7214	EACH	\$20.96
pewag Cross Chains with Hooks	USA 7214 8ST	EACH	\$51.30

pewag Cross Chains with Hooks	USA 7215	EACH	\$22.67	
pewag Cross Chains with Hooks	USA 7215 8ST	EACH	\$54.51	
pewag Cross Chains with Hooks	USA 7216	EACH	\$26.08	
pewag Cross Chains with Hooks	USA 7420 10mm	EACH	\$42.80	
pewag Cross Chains with Hooks	USA 7420 8.2mm	EACH	\$26.86	
pewag Cross Chains with Hooks	USA 7426 10mm	EACH	\$52.64	
pewag Cross Chains with Hooks	USA 7426 8.2mm	EACH	\$31.93	
pewag CL-PSC	USA 91 PSC	PAIR	\$562.92	
pewag CL-PSC	USA 93 7 PSC	PAIR	\$565.76	
pewag CL-PSC	USA 94 PSC	PAIR	\$666.31	
pewag CL-PSC	USA 95 PSC	PAIR	\$675.43	
pewag Cross Chains with Hooks	USA 9562 10mm	EACH	\$62.49	
pewag Cross Chains with Hooks	USA 9562 12mm	EACH	\$86.71	
pewag Cross Chains with Hooks	USA 9567 10mm	EACH	\$72.33	
pewag Cross Chains with Hooks	USA 9567 12mm	EACH	\$106.20	
pewag CL-PSC	USA 97 PSC	PAIR	\$675.43	
pewag Forklift Chains	USA25015S 7mm	PAIR	\$323.71	
pewag Forklift Chains	USA28915S 5.6mm	PAIR	\$286.52	
pewag Forklift Chains	USA30015S 7mm DS	PAIR	\$614.07	
pewag Forklift Chains	USA65010S 4.5mm DS	PAIR	\$209.26	
pewag Forklift Chains	USA65010S 5.6mm DS	PAIR	\$279.02	
pewag Forklift Chains	USA65010S 7mm DS	PAIR	\$372.03	
pewag Forklift Chains	USA70012S 5.6mm DS	PAIR	\$331.96	
pewag Forklift Chains	USA70012S 7mm	PAIR	\$320.87	
pewag Forklift Chains	USA70012S 7mm DS	PAIR	\$609.66	
pewag Forklift Chains	USA70015S 5.6mm	PAIR	\$249.00	
pewag Skid Steer Chains - Ladder	USASSE 10165-2	PAIR	\$840.51	
pewag Skid Steer Chains - Ladder	USASSE 10165-4	PAIR	\$521.52	
pewag Skid Steer Chains - Ladder	USASSE 12165 PS	PAIR	\$872.93	
pewag Skid Steer Chains - Ladder	USASSE 12165 PSC	PAIR	\$872.93	
pewag Skid Steer Chains - Ladder	USASSE 12165-2	PAIR	\$899.93	
pewag Skid Steer Chains - Ladder	USASSE 12165-4	PAIR	\$578.02	
pewag Skid Steer Chains - Ladder	USASSE 14175-2	PAIR	\$1,132.96	
pewag Skid Steer Chains - Ladder	USASSE 14175-4	PAIR	\$674.66	
pewag Skid Steer Chains - Ladder	USASSE 3112165-2	PAIR	\$757.84	
pewag Skid Steer Chains - Ladder	USASSE 3112165-4	PAIR	\$520.21	
Pewag Zig Zag Chain	USA ZZ 2228 SC	PAIR	\$374.78	Items 14,15
Pewag Zig Zag Chain	USAZZ 2247 S 7	PAIR	\$493.02	
Pewag Zig Zag Chain	USAZZ 2247 S 7ST	PAIR	\$623.39	
Pewag Zig Zag Chain	USAZZ 2247 S 8ST	PAIR	\$772.47	
Pewag Zig Zag Chain	USAZZ 2247 SC 7	PAIR	\$526.37	
Pewag Zig Zag Chain	USAZZ 2247 SC 7ST	PAIR	\$645.19	
Pewag Zig Zag Chain	USAZZ 2247 SC 8ST	PAIR	\$788.27	
Pewag Zig Zag Chain	USAZZ 2249 S 7	PAIR	\$493.02	
Pewag Zig Zag Chain	USAZZ 2249 S 7ST	PAIR	\$649.35	
Pewag Zig Zag Chain	USAZZ 2249 S 8ST	PAIR	\$766.10	
Pewag Zig Zag Chain	USAZZ 2249 SC 7	PAIR	\$526.37	
Pewag Zig Zag Chain	USAZZ 2249 SC 7ST	PAIR	\$672.09	
Pewag Zig Zag Chain	USAZZ 2249 SC 8ST	PAIR	\$781.75	
Pewag Zig Zag Chain	USAZZ 2255 S 7	PAIR	\$546.89	
Pewag Zig Zag Chain	USAZZ 2255 S 7ST	PAIR	\$637.50	
Pewag Zig Zag Chain	USAZZ 2255 S 8ST	PAIR	\$808.33	
Pewag Zig Zag Chain	USAZZ 2255 SC 7	PAIR	\$560.92	
Pewag Zig Zag Chain	USAZZ 2255 SC 7ST	PAIR	\$654.23	

Pewag Zig Zag Chain	USAZZ 2255 SC 8ST	PAIR	\$829.06
Pewag Zig Zag Chain	USAZZ 3229 S 7	PAIR	\$383.13
Pewag Zig Zag Chain	USAZZ 3229 S 7ST	PAIR	\$506.42
Pewag Zig Zag Chain	USAZZ 3229 SC 7	PAIR	\$396.51
Pewag Zig Zag Chain	USAZZ 3229 SC 7ST	PAIR	\$526.32
Pewag Zig Zag Chain	USAZZ 3269 S 7	PAIR	\$542.80
Pewag Zig Zag Chain	USAZZ 3269 S 7ST	PAIR	\$766.19
Pewag Zig Zag Chain	USAZZ 3269 SC 7	PAIR	\$561.79
Pewag Zig Zag Chain	USAZZ 3269 SC 7ST	PAIR	\$784.95
pewag brenta-c 4x4	XMR69V	PAIR	\$305.01
pewag brenta-c 4x4	XMR 73 V	PAIR	\$305.01
pewag brenta-c 4x4	XMR 74 V	PAIR	\$305.01
pewag brenta-c 4x4	XMR 75 V	PAIR	\$328.47
pewag brenta-c 4x4	XMR 76 V	PAIR	\$328.47
pewag brenta-c 4x4	XMR 77 V	PAIR	\$328.47
pewag brenta-c 4x4	XMR 79 V	PAIR	\$328.47
pewag brenta-c 4x4	XMR 80 V	PAIR	\$360.74
pewag brenta-c 4x4	XMR 80A V	PAIR	\$360.74
pewag brenta-c 4x4	XMR 81 V	PAIR	\$360.74
pewag brenta-c 4x4	XMR 82 V	PAIR	\$360.74

DESIGNATED CONTACT: Vendor appoints the individual identified in this Section as the Contract Administrator and the initial point of contact for matters relating to this Contract.

Tammy Knight, Eastern Sales Manager

(Name, Title)

Tammy Knight, Eastern Sales Manager

(Printed Name and Title)

3 Coolview Lane Bridgeport, WV 26330

(Address)

Phone 304-641-3132 Fax 866-472-8775

(Phone Number) / (Fax Number)

tammyk@pewagchain.com

(email address)

CERTIFICATION AND SIGNATURE: By signing below, or submitting documentation through wvOASIS, I certify that I have reviewed this Solicitation in its entirety; that I understand the requirements, terms and conditions, and other information contained herein; that this bid, offer or proposal constitutes an offer to the State that cannot be unilaterally withdrawn; that the product or service proposed meets the mandatory requirements contained in the Solicitation for that product or service, unless otherwise stated herein; that the Vendor accepts the terms and conditions contained in the Solicitation, unless otherwise stated herein; that I am submitting this bid, offer or proposal for review and consideration; that I am authorized by the vendor to execute and submit this bid, offer, or proposal, or any documents related thereto on vendor's behalf; that I am authorized to bind the vendor in a contractual relationship; and that to the best of my knowledge, the vendor has properly registered with any State agency that may require registration.

pewag Traction Chain, Inc

(Company)

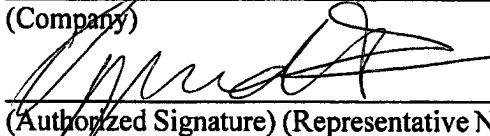
 **OPPENRIEDER FLORIAN, GM**

(Authorized Signature) (Representative Name, Title)

Florian Oppenrieder, General Manager

(Printed Name and Title of Authorized Representative)

December 18, 2019

(Date)

Phone 800-445-2895 Fax 916-408-0575

(Phone Number) (Fax Number)

EXHIBIT B: DIVISION OF HIGHWAYS LOCATIONS

Equipment Division
WV Division of Highways
P.O. Box 610
Buckhannon, WV. 26201
Attn: Tammy Clevenger (FOUR COPIES)

WVDOT/Division of Highways
District 6 Headquarters
1 DOT Drive
Moundsville, WV. 26041-2353
Attn: Mike McGreal

WVDOT/Division of Highways
District 1 Headquarters
1340 Smith St.
Charleston, WV. 25301
Attn: Bob Heckert

WVDOT/Division of Highways
District 7 Headquarters
Drawer 1228
Weston, WV. 26452
Attn: Melissa Jordan

WVDOT/Division of Highways
District 2 Headquarters
P.O. Box 880
Huntington, WV. 25712
Attn: Linda Hatfield-Corder

WVDOT/Division of Highways
District 8 Headquarters
P.O. Box 1516
Elkins, WV. 26241
Attn: Debbie Barnett

WVDOT/Division of Highways
District 3 Headquarters
626 Depot St.
Parkersburg, WV. 26101
Attn: Karen Greenburg

WVDOT/Division of Highways
District 9 Headquarters
103 1/2 Church Street
Lewisburg, WV. 24901
Attn:

WVDOT/Division of Highways
District 4 Headquarters
P.o. Box 2570
Clarksburg, WV. 26301
Attn: Bryan Henry

WVDOT/Division of Highways
District 10 Headquarters
270 Hardwood Lane
Princeton, WV. 24740
Attn: Angela Roske

WVDOT/Division of Highways
District 5 Headquarters
P.O. Box 99
Burlington, WV. 26710
Attn: Laranda Baldwin

West Virginia Ethics Commission



Disclosure of Interested Parties to Contracts

Pursuant to *W. Va. Code* § 6D-1-2, a state agency may not enter into a contract, or a series of related contracts, that has/have an actual or estimated value of \$1 million or more until the business entity submits to the contracting state agency a Disclosure of Interested Parties to the applicable contract. In addition, the business entity awarded a contract is obligated to submit a supplemental Disclosure of Interested Parties reflecting any new or differing interested parties to the contract within 30 days following the completion or termination of the applicable contract.

For purposes of complying with these requirements, the following definitions apply:

"Business entity" means any entity recognized by law through which business is conducted, including a sole proprietorship, partnership or corporation, but does not include publicly traded companies listed on a national or international stock exchange.

"Interested party" or *"Interested parties"* means:

- (1) A business entity performing work or service pursuant to, or in furtherance of, the applicable contract, including specifically sub-contractors;
- (2) the person(s) who have an ownership interest equal to or greater than 25% in the business entity performing work or service pursuant to, or in furtherance of, the applicable contract. (This subdivision does not apply to a publicly traded company); and
- (3) the person or business entity, if any, that served as a compensated broker or intermediary to actively facilitate the applicable contract or negotiated the terms of the applicable contract with the state agency. (This subdivision does not apply to persons or business entities performing legal services related to the negotiation or drafting of the applicable contract.)

"State agency" means a board, commission, office, department or other agency in the executive, judicial or legislative branch of state government, including publicly funded institutions of higher education: Provided, that for purposes of *W. Va. Code* § 6D-1-2, the West Virginia Investment Management Board shall not be deemed a state agency nor subject to the requirements of that provision.

The contracting business entity must complete this form and submit it to the contracting state agency prior to contract award and to complete another form within 30 days of contract completion or termination.

This form was created by the State of West Virginia Ethics Commission, 210 Brooks Street, Suite 300, Charleston, WV 25301-1804. Telephone: (304)558-0664; fax: (304)558-2169; e-mail: ethics@wv.gov; website: www.ethics.wv.gov.

West Virginia Ethics Commission
Disclosure of Interested Parties to Contracts

(Required by W. Va. Code § 6D-1-2)

Name of Contracting Business Entity: pewag Traction Chain, Inc Address: 190 Greenhorn Drive
Pueblo, CO 81004

Name of Authorized Agent: Florian Oppenrieder Address: 190 Greenhorn Drive Pueblo, CO 81004

Contract Number: DOT2000000070 Contract Description: Tire and Cross Chains, Components & Accessories

Governmental agency awarding contract: WV Dept of Transportation and WV Division of Highways

Check here if this is a Supplemental Disclosure

List the Names of Interested Parties to the contract which are known or reasonably anticipated by the contracting business entity for each category below (attach additional pages if necessary):

- 1. **Subcontractors or other entities performing work or service under the Contract**
 Check here if none, otherwise list entity/individual names below.

- 2. **Any person or entity who owns 25% or more of contracting entity (not applicable to publicly traded entities)**
 Check here if none, otherwise list entity/individual names below.

- 3. **Any person or entity that facilitated, or negotiated the terms of, the applicable contract (excluding legal services related to the negotiation or drafting of the applicable contract)**
 Check here if none, otherwise list entity/individual names below.

Signature: [Handwritten Signature] Date Signed: 12/18/2019

Notary Verification

State of COLORADO, County of PUEBLO:

I, FLORIAN OPPENRIEDER, the authorized agent of the contracting business entity listed above, being duly sworn, acknowledge that the Disclosure herein is being made under oath and under the penalty of perjury.

Taken, sworn to and subscribed before me this 18th day of December, 2019

[Handwritten Signature]
Notary Public's Signature



To be completed by State Agency:
Date Received by State Agency: _____
Date submitted to Ethics Commission: _____
Governmental agency submitting Disclosure: _____

STATE OF WEST VIRGINIA
Purchasing Division

PURCHASING AFFIDAVIT

CONSTRUCTION CONTRACTS: Under W. Va. Code § 5-22-1(i), the contracting public entity shall not award a construction contract to any bidder that is known to be in default on any monetary obligation owed to the state or a political subdivision of the state, including, but not limited to, obligations related to payroll taxes, property taxes, sales and use taxes, fire service fees, or other fines or fees.

ALL CONTRACTS: Under W. Va. Code §5A-3-10a, no contract or renewal of any contract may be awarded by the state or any of its political subdivisions to any vendor or prospective vendor when the vendor or prospective vendor or a related party to the vendor or prospective vendor is a debtor and: (1) the debt owed is an amount greater than one thousand dollars in the aggregate; or (2) the debtor is in employer default.

EXCEPTION: The prohibition listed above does not apply where a vendor has contested any tax administered pursuant to chapter eleven of the W. Va. Code, workers' compensation premium, permit fee or environmental fee or assessment and the matter has not become final or where the vendor has entered into a payment plan or agreement and the vendor is not in default of any of the provisions of such plan or agreement.

DEFINITIONS:

"Debt" means any assessment, premium, penalty, fine, tax or other amount of money owed to the state or any of its political subdivisions because of a judgment, fine, permit violation, license assessment, defaulted workers' compensation premium, penalty or other assessment presently delinquent or due and required to be paid to the state or any of its political subdivisions, including any interest or additional penalties accrued thereon.

"Employer default" means having an outstanding balance or liability to the old fund or to the uninsured employers' fund or being in policy default, as defined in W. Va. Code § 23-2c-2, failure to maintain mandatory workers' compensation coverage, or failure to fully meet its obligations as a workers' compensation self-insured employer. An employer is not in employer default if it has entered into a repayment agreement with the Insurance Commissioner and remains in compliance with the obligations under the repayment agreement.

"Related party" means a party, whether an individual, corporation, partnership, association, limited liability company or any other form or business association or other entity whatsoever, related to any vendor by blood, marriage, ownership or contract through which the party has a relationship of ownership or other interest with the vendor so that the party will actually or by effect receive or control a portion of the benefit, profit or other consideration from performance of a vendor contract with the party receiving an amount that meets or exceeds five percent of the total contract amount.

AFFIRMATION: By signing this form, the vendor's authorized signer affirms and acknowledges under penalty of law for false swearing (W. Va. Code §61-5-3) that: (1) for construction contracts, the vendor is not in default on any monetary obligation owed to the state or a political subdivision of the state, and (2) for all other contracts, that neither vendor nor any related party owe a debt as defined above and that neither vendor nor any related party are in employer default as defined above, unless the debt or employer default is permitted under the exception above.

WITNESS THE FOLLOWING SIGNATURE:

Vendor's Name: pewag TRACTION Chain, Inc

Authorized Signature: [Signature] Date: 12/18/2019

State of COLORADO

County of PUEBLO, to-wit:

Taken, subscribed, and sworn to before me this 18th day of December, 2019.

My Commission expires January 6, 2022

AFFIX SEAL HERE

NOTARY PUBLIC

[Signature]

Purchasing Affidavit (Revised 01/19/2018)

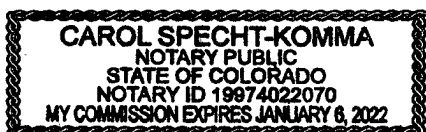

REQUEST FOR QUOTATION
CRFQ DOT2000000070
Tire and Cross Chains, Components & Accessories (7020C004)

SPECIFICATIONS

1. **PURPOSE AND SCOPE:** The West Virginia Purchasing Division is soliciting bids on behalf of West Virginia Department of Transportation, the West Virginia Division of Highways to establish an open-end contract for Tire and Cross chains, Components & Accessories.

2. **DEFINITIONS:** The terms listed below shall have the meanings assigned to them below. Additional definitions can be found in section 2 of the General Terms and Conditions.
 - 2.1 **“Adjusted Unit Price”** means the Unit Price either reduced by the Discount Percentage or increased by the Markup Percentage.

 - 2.2 **“Attachment” or “Attachments”** means any device that is not integrated to the original manufacturers design that modifies or expands the range of tasks that can be done by the equipment or motor vehicle; or alters the capacity, stability, or operation of that equipment of motor vehicle.

 - 2.3 **“Catalog”** means the current price list or sales catalog that includes Contract Items or Contract Items that the vendor can and will sell under this contract.

 - 2.4 **“Catalog Unit Price”** means the lowest price listed for a Contract Item in Vendors Current Catalog.

 - 2.5 **“Contract Item” or “Contract Items”** means the list of items identified in Section 3.1 below and on the Pricing Pages.

 - 2.6 **“Discount Percentage”** means the percentage discount that Vendor will apply to all Agency purchases of Contract Item or Contract Items.

 - 2.7 **“OEM or “Original Equipment Manufacturer”** means the Manufacturer or Manufacturers involved in the original assembly.

 - 2.8 **“Or Equal”** means Contract Item or Items must meet or exceed the Original Equipment Manufacturers (OEM) standards in form, fit and function.

 - 2.9 **“Markup Percentage”** means the percentage markup that Vendor will apply to all Agency purchases of Contract Item or Contract Items

 - 2.10 **“Part” or “Parts”** means any system, part or component of equipment or motor vehicles as originally manufactured; or any similar part or component manufactured or sold for replacement or improvement or a system, part or component, or as an accessory to equipment or motor vehicle.

**REQUEST FOR QUOTATION
CRFQ DOT2000000070
Tire and Cross Chains, Components & Accessories (7020C004)**

2.11 “Pricing pages” means the schedule of prices, estimated order quantity, and totals contained in wvOASIS or attached hereto as Exhibit A and use to evaluate the Solicitation responses.

2.12 “HRC” means an abbreviation for Rockwell Hardness measured on the C scale. A designation of hardness, usually of Steel or Corrosion Resistant Alloys.

2.13 “Solicitation” means the official notice of an opportunity to supply the State with goods or services that is published by the Purchasing Division.

2.14 “Total Bid Price” means the sum of the bid total column.

2.15 “N/mm2” means Newton/Square Millimeter or Micrometre (International spelling).

2.16 “mm” means millimeter.

3. GENERAL REQUIREMENTS:

3.1 Contract Items and Mandatory Requirements: Vendor shall provide Agency with the Contract Items listed below on an open-end and continuing basis. Contract Items must meet or exceed the mandatory requirements as shown below.

3.1.1.1 Vendor must be ISO 9001 and ISO 14001 certified and should provide proof of certification with bid and will be required prior to award.

3.1.1.2 Vendor should provide a product specification sheet with bid and will be required prior to award.

3.1.1.3 Contract Item must meet or exceed all of the latest requirements of the National Association of Chain Manufacturers www.nacm.info. Squared links or wave profile links are acceptable, along with studded chain.

3.1.1.4 Contract items must be compatible with radial and bias ply tires and work equally well with passenger cars, trucks and off-road equipment.

3.1.1.5 All chains shall be zinc plated surface finish for corrosion protection with minimum thickness of 5 Micrometers.

REQUEST FOR QUOTATION
CRFQ DOT2000000070
Tire and Cross Chains, Components & Accessories (7020C004)

- 3.1.1.6** All chains shall have a minimum surface hardness of 62 HRC.
- 3.1.1.7** All chains shall have a minimum core hardness of 49 HRC.
- 3.1.1.8** All chains shall have a minimum case hardness of 61 HRC.
- 3.1.1.9** All chains shall have a case hardening minimum depth of 6% (six percent) from link surface.
- 3.1.1.10** All chains shall be reversible and repairable, and shall have repair links available that are consistent in wire size, link size, shape and quality with the links of original chain with a deviation tolerance of +/- 0.3%
- 3.1.1.11** All chains shall be packaged no more than 1 (one) set per bag or box with dimension tag and mounting instructions.
- 3.1.1.12** All chains shall be delivered on shrink wrapped pallets. Pallets will not be returned to vendor and any pallet core charge will be the responsibility of the vendor.
- 3.1.1.13** Chain links must be nickel manganese alloy or equal.
- 3.1.1.14** Chain links must be equipped with cam lock feature.
- 3.1.1.15** Link cross chains must be high strength alloy steel.
- 3.1.1.16** All cross chains shall be packaged no more than 50 (fifty) per bag or box.
- 3.1.1.17** Chain tread links square section shall be minimum thickness of 7mm.
- 3.1.1.18** Side chain inside and outside shall be minimum thickness of 6mm.
- 3.1.1.19** Minimum breaking stress of the tread net parts shall be 300 N/mm².
- 3.1.1.20** Fitting shall be throw-over style.

REQUEST FOR QUOTATION
CRFQ DOT2000000070
Tire and Cross Chains, Components & Accessories (7020C004)

3.1.1.21 This contract shall be limited to the items included in the manufacturers catalog submitted prior to award of this contract.

4. CONTRACT AWARD, PRICING PAGES, DISCOUNT/MARKUP PERCENTAGE:

4.1 Contract Award: The Contract is intended to provide Agencies with a purchase price on all Contract Items. The Contract shall be awarded to the Vendor that provides the Contract Items meeting the required specifications for the lowest overall total cost as shown on the Pricing Pages.

4.2 Discount Percentage: Vendor may quote a single Discount Percentage that will reduce the lowest price shown in the Catalog for every Contract Item. The resulting Adjusted Unit Price shall be the price Agency pay for purchases of that Contract Item under this Contract.

Vendor shall not incorporate Discount Percentages into its Catalog unless the Vendor clearly shows the Catalog Price and then separately lists the applicable Discount Percentage and the Adjusted Unit Price for each Contract Item.

The Discount Percentage and subsequent Adjusted Unit Price derived from that discount must consider all fees, charges, or other miscellaneous costs that the Vendor may require, including delivery charges as indicated below, because those fees, charges, or other miscellaneous costs will not be paid separately. The Agency shall only pay the appropriate Adjusted Unit Price for items purchased under this Contract.

4.3 Markup Percentage: Vendor may quote a single Markup Percentage that will increase the lowest price shown in the Catalog for every Contract Item. The resulting Adjusted Unit Price shall be the price Agency pay for purchases of that Contract Item under this Contract.

Vendor shall not incorporate Markup Percentages into its Catalog unless the Vendor clearly shows the Catalog Price and then separately lists the applicable Markup Percentage and the Adjusted Unit Price for each Contract Item.

The Markup Percentage and subsequent Adjusted Unit Price derived from that markup must consider all fees, charges, or other miscellaneous costs that the

**REQUEST FOR QUOTATION
CRFQ DOT200000070
Tire and Cross Chains, Components & Accessories (7020C004)**

Vendor may require, including delivery charges as indicated below, because those fees, charges, or other miscellaneous costs will not be paid separately. The Agency shall only pay the appropriate Adjusted Unit Price for items purchased under this Contract.

Vendor shall only quote either a Discount Percentage or a Markup Percentage per Solicitation. If a solicitation response contains both a Discount Percentage and a Markup Percentage for the same bid response, the bid response will be disqualified.

- 4.4 Pricing Pages:** Vendor shall complete the Pricing Pages by inserting either a Discount Percentage or a Markup Percentage. Vendor should insert the Catalog Unit Price from Vendor's current catalog for each of the items listed. Vendor's bidding an "or Equal" product line must reference their part number for each of the "OEM" part numbers as they coincide on the Pricing Pages. Vendor should complete the Pricing Pages in their entirety as failure to do so may result in Vendor's bids being disqualified.

The Pricing Pages contain a list of the Contract Items and estimated purchase volume. All Contract Items contained on the Pricing Pages shall be bid as "NEW". Rebuilt or reconditioned pricing will not be accepted for bidding purposes. The estimated purchase volume for each item represents the approximate volume of anticipated purchases only. No future use of the Contract or any individual item is guaranteed or implied.

Vendors are **strongly encouraged** to complete the Pricing Pages through WVOasis or electronically in Microsoft Excel. Doing so will reduce the number of, and the possibility for calculation errors. The Pricing Pages were created as a Microsoft Excel document and Vendor can request an electronic copy for bid purposes by sending an email request to the following address: Crystal.G.Hustead@wv.gov

The Purchasing Division reserves the right to take Vendor's Pricing Pages and insert the appropriate numbers into the Microsoft Excel spreadsheet if Vendor chooses to complete the Pricing Pages in any other way.

PLEASE READ THIS SECTION IN IT'S ENTIRETY IF VENDOR IS SUBMITTING AN ELECTRONIC BID:

Vendor **MUST** complete the ATTACHED Pricing Page, Exhibit A. If bidding electronically, Vendor is to put \$0.00 on the commodity line in WVOasis, complete the Excel pricing page, and upload into WVOasis as an attachment. Only pricing submitted via Exhibit A pricing page will be evaluated for award.

REQUEST FOR QUOTATION
CRFQ DOT2000000070
Tire and Cross Chains, Components & Accessories (7020C004)

5. CATALOG

- 5.1 Submission:** Vendor should submit its Catalog with bid but must submit it prior to award of this contract for evaluation purposes. Vendor shall also mail the Catalog free of charge to any Agency desiring to use this contract. Copies of the Catalog may be requested in an electronic format and should be provided in that format if possible. Vendor's Catalog will be used by Agencies to order Contract Items under this Contract.

Vendor should identify all items listed on the Pricing Section by circling or highlighting those items in its Catalog and earmarking or tabbing the pages for those items, to assist in the evaluation and verification of the bids and pricing. If any discrepancies exist between the Pricing Pages and the Unit Price listed in the Catalog, the Unit Price shall prevail, and the Pricing Pages may be corrected by the Purchasing Division buyer for evaluation purposes.

- 5.2 Catalog Modification:** The Purchasing Division may permit Vendor to update its Catalog at each renewal date. Determination of whether to allow a Catalog update is at the sole discretion of the Purchasing Division. Any request by Vendor to update its Catalog must include a detailed listing of the following: (1) any Contract Items being removed, Discounted Unit Price for those items, Agencies quantity usage of those items, and total spent by the Agencies on those items; (2) any Contract Items being added to the Catalog and the Discounted Unit Price of those items; (3) all changes in the Discounted Unit Price to Contract Items, estimated usage relating to items that have changed in price, and the total impact of the price change on the State; and (4) justification for updating its Catalog. The Purchasing Division may waive the detailed listing requirements if it finds that doing so is in the best interest of the State. Unless an updated catalog is approved, the Contract Items available under this Contract and Unit Prices for those items shall remain unchanged during the term of this Contract

6. ORDERING AND PAYMENT:

- 6.1 Ordering:** Vendor shall accept orders through WV Oasis, regular mail, facsimile, e-mail, or any other written form of communication. Vendor may, but is not required to, accept on-line orders through a secure internet ordering portal/website. If Vendor has the ability to accept on-line orders, it should include in its response a brief description of how Agency may utilize the on-line ordering system. Any on-line ordering system must have the capability to restrict prices and available items to

REQUEST FOR QUOTATION
CRFQ DOT200000070
Tire and Cross Chains, Components & Accessories (7020C004)

conform to the Catalog originally submitted with this Solicitation. Vendor shall ensure that its on-line ordering system is properly secured prior to processing Agency orders on-line.

Vendor shall provide the Purchasing Division with access to its internet ordering portal/website, if one will be used under this contract, to allow the Purchasing Division to ensure that the requirements of this Contract are being met.

- 6.2 Payment:** Vendor shall accept payment in accordance with the payment procedures of the State of West Virginia. Methods of payment must include the West Virginia Purchasing Card. Payment in advance is not permitted under this Contract.

7. Delivery AND RETURN:

- 7.1 Delivery Time:** Vendor shall ship/deliver standard orders within five (5) working days after orders are received. Vendor shall deliver emergency orders within one (1) working day, upon the Agencies request. Delivery must be made during Agencies normal work hours. Vendor shall ship all orders in accordance with the above schedule and shall not hold orders until a minimum delivery quantity is met. Contract Items must be delivered to the ordering Agency attached hereto as Exhibit B.

- 7.2 Late Delivery:** The Agency placing the order under this Contract must be notified in writing if orders will be delayed for any reason. Any delay in delivery that could cause harm to an Agency will be grounds for cancellation of the delayed order, and/or obtaining the items ordered from a third party.

Any Agency seeking to obtain items from a third party under this provision must first obtain approval of the Purchasing Division.

- 7.3 Delivery Payment/Risk of Loss:** Standard order delivery shall be F.O.B. Destination to the Agency's location. Vendor shall include the cost of standard delivery charges in its bid pricing and is not permitted to charge the Agency separately for such delivery. The Agency will pay delivery charges on all emergency orders provided that the Agency requests emergency delivery and

Vendor invoices those delivery costs as a separate charge with the original freight bill attached to the invoice.

REQUEST FOR QUOTATION
CRFQ DOT2000000070
Tire and Cross Chains, Components & Accessories (7020C004)

- 7.4 Return of Unacceptable Items:** If the Agency deems the Contract Items to be unacceptable, the Contract Items shall be returned to Vendor at Vendor's expense and with no restocking charge. Vendor shall either make arrangements for the return within five (5) days of being notified that items are unacceptable or permit the Agency to arrange for the return and reimburse Agency for delivery expenses. If the original packaging cannot be utilized for the return, Vendor will supply the Agency with appropriate return packaging upon request. All returns of unacceptable items shall be F.O.B. the Agency's location. The returned product shall either be replaced, or the Agency shall receive a full credit or refund for the purchase price, at the Agency's discretion.
- 7.5 Return Due to Agency Error:** Items ordered in error by the Agency will be returned for credit within 30 days of receipt, F.O.B. Vendor's location. Vendor shall not charge a restocking fee if returned products are in a resalable condition. Items shall be deemed to be in a resalable condition if they are unused and in the original packaging. Any restocking fee for items not in a resalable condition shall be the lower of the Vendor's customary restocking fee or 5% of the total invoiced value of the returned items.

8. VENDOR DEFAULT:

- 8.1** The following shall be considered a vendor default under this Contract.
- 8.1.1** Failure to provide Contract Items in accordance with the requirements contained herein.
 - 8.1.2** Failure to comply with other specifications and requirements contained herein.
 - 8.1.3** Failure to comply with any laws, rules, and ordinances applicable to the Contract Services provided under this Contract.
 - 8.1.4** Failure to remedy deficient performance upon request
- 8.2** The following remedies shall be available to Agency upon default.
- 8.2.1** Immediate cancellation of the Contract.
 - 8.2.2** Immediate cancellation of one or more release orders issued under this Contract.
 - 8.2.3** Any other remedies available in law or equity.

**REQUEST FOR QUOTATION
CRFQ DOT2000000070
Tire and Cross Chains, Components & Accessories (7020C004)**

9. Miscellaneous:

- 9.2 No Substitutions:** Vendor shall supply only Contract Items submitted in response to the Solicitation unless a contract modification is approved in accordance with the provisions contained in this Contract.
- 9.3 Vendor Supply:** Vendor must carry sufficient inventory of the Contract Items being offered to fulfill its obligations under this Contract. By signing its bid, Vendor certifies that it can supply the Contract Items contained in its bid response.
- 9.4 Reports:** Vendor shall provide quarterly reports and annual summaries to the Agency showing the Agency's items purchased, quantities of items purchased, and total dollar value of the items purchased. Vendor shall also provide reports, upon request, showing the items purchased during the term of this Contract, the quantity purchased for each of those items, and the total value of purchases for each of those items. Failure to supply such reports may be grounds for cancellation of this Contract.
- 9.5 Contract Manager:** During its performance of this Contract, Vendor must designate and maintain a primary contract manager responsible for overseeing Vendor's responsibilities under this Contract. The Contract manager must be available during normal business hours to address any customer service or other issues related to this Contract. Vendor should list its Contract manager and his or her contact information below.

Contract Manager: Tammy Knight

Telephone Number: 304-641-3132

Fax Number: 866-472-8775

Email Address: tammyk@pewagchain.com

GENERAL TERMS AND CONDITIONS:

1. CONTRACTUAL AGREEMENT: Issuance of a Award Document signed by the Purchasing Division Director, or his designee, and approved as to form by the Attorney General's office constitutes acceptance of this Contract made by and between the State of West Virginia and the Vendor. Vendor's signature on its bid signifies Vendor's agreement to be bound by and accept the terms and conditions contained in this Contract.

2. DEFINITIONS: As used in this Solicitation/Contract, the following terms shall have the meanings attributed to them below. Additional definitions may be found in the specifications included with this Solicitation/Contract.

2.1. "Agency" or "Agencies" means the agency, board, commission, or other entity of the State of West Virginia that is identified on the first page of the Solicitation or any other public entity seeking to procure goods or services under this Contract.

2.2. "Bid" or "Proposal" means the vendors submitted response to this solicitation.

2.3. "Contract" means the binding agreement that is entered into between the State and the Vendor to provide the goods or services requested in the Solicitation.

2.4. "Director" means the Director of the West Virginia Department of Administration, Purchasing Division.

2.5. "Purchasing Division" means the West Virginia Department of Administration, Purchasing Division.

2.6. "Award Document" means the document signed by the Agency and the Purchasing Division, and approved as to form by the Attorney General, that identifies the Vendor as the contract holder.

2.7. "Solicitation" means the official notice of an opportunity to supply the State with goods or services that is published by the Purchasing Division.

2.8. "State" means the State of West Virginia and/or any of its agencies, commissions, boards, etc. as context requires.

2.9. "Vendor" or "Vendors" means any entity submitting a bid in response to the Solicitation, the entity that has been selected as the lowest responsible bidder, or the entity that has been awarded the Contract as context requires.

3. CONTRACT TERM; RENEWAL; EXTENSION: The term of this Contract shall be determined in accordance with the category that has been identified as applicable to this Contract below:

Term Contract

Initial Contract Term: **Initial Contract Term:** This Contract becomes effective on award and extends for a period of one (1) year(s).

Renewal Term: This Contract may be renewed upon the mutual written consent of the Agency, and the Vendor, with approval of the Purchasing Division and the Attorney General's office (Attorney General approval is as to form only). Any request for renewal should be delivered to the Agency and then submitted to the Purchasing Division thirty (30) days prior to the expiration date of the initial contract term or appropriate renewal term. A Contract renewal shall be in accordance with the terms and conditions of the original contract. Unless otherwise specified below, renewal of this Contract is limited to three (3) successive one (1) year periods or multiple renewal periods of less than one year, provided that the multiple renewal periods do not exceed the total number of months available in all renewal years combined. Automatic renewal of this Contract is prohibited. Renewals must be approved by the Vendor, Agency, Purchasing Division and Attorney General's office (Attorney General approval is as to form only)

Alternate Renewal Term – This contract may be renewed for _____ successive _____ year periods or shorter periods provided that they do not exceed the total number of months contained in all available renewals. Automatic renewal of this Contract is prohibited. Renewals must be approved by the Vendor, Agency, Purchasing Division and Attorney General's office (Attorney General approval is as to form only)

Delivery Order Limitations: In the event that this contract permits delivery orders, a delivery order may only be issued during the time this Contract is in effect. Any delivery order issued within one year of the expiration of this Contract shall be effective for one year from the date the delivery order is issued. No delivery order may be extended beyond one year after this Contract has expired.

Fixed Period Contract: This Contract becomes effective upon Vendor's receipt of the notice to proceed and must be completed within _____ days.

Fixed Period Contract with Renewals: This Contract becomes effective upon Vendor's receipt of the notice to proceed and part of the Contract more fully described in the attached specifications must be completed within _____ days. Upon completion of the work covered by the preceding sentence, the vendor agrees that maintenance, monitoring, or warranty services will be provided for _____ year(s) thereafter.

One Time Purchase: The term of this Contract shall run from the issuance of the Award Document until all of the goods contracted for have been delivered, but in no event will this Contract extend for more than one fiscal year.

Other: See attached.

4. NOTICE TO PROCEED: Vendor shall begin performance of this Contract immediately upon receiving notice to proceed unless otherwise instructed by the Agency. Unless otherwise specified, the fully executed Award Document will be considered notice to proceed.

5. QUANTITIES: The quantities required under this Contract shall be determined in accordance with the category that has been identified as applicable to this Contract below.

Open End Contract: Quantities listed in this Solicitation are approximations only, based on estimates supplied by the Agency. It is understood and agreed that the Contract shall cover the quantities actually ordered for delivery during the term of the Contract, whether more or less than the quantities shown.

Service: The scope of the service to be provided will be more clearly defined in the specifications included herewith.

Combined Service and Goods: The scope of the service and deliverable goods to be provided will be more clearly defined in the specifications included herewith.

One Time Purchase: This Contract is for the purchase of a set quantity of goods that are identified in the specifications included herewith. Once those items have been delivered, no additional goods may be procured under this Contract without an appropriate change order approved by the Vendor, Agency, Purchasing Division, and Attorney General's office.

6. EMERGENCY PURCHASES: The Purchasing Division Director may authorize the Agency to purchase goods or services in the open market that Vendor would otherwise provide under this Contract if those goods or services are for immediate or expedited delivery in an emergency. Emergencies shall include, but are not limited to, delays in transportation or an unanticipated increase in the volume of work. An emergency purchase in the open market, approved by the Purchasing Division Director, shall not constitute of breach of this Contract and shall not entitle the Vendor to any form of compensation or damages. This provision does not excuse the State from fulfilling its obligations under a One Time Purchase contract.

7. REQUIRED DOCUMENTS: All of the items checked below must be provided to the Purchasing Division by the Vendor as specified below.

BID BOND (Construction Only): Pursuant to the requirements contained in W. Va. Code § 5-22-1(c), All Vendors submitting a bid on a construction project shall furnish a valid bid bond in the amount of five percent (5%) of the total amount of the bid protecting the State of West Virginia. The bid bond must be submitted with the bid.

PERFORMANCE BOND: The apparent successful Vendor shall provide a performance bond in the amount of 100% of the contract. The performance bond must be received by the Purchasing Division prior to Contract award.

LABOR/MATERIAL PAYMENT BOND: The apparent successful Vendor shall provide a labor/material payment bond in the amount of 100% of the Contract value. The labor/material payment bond must be delivered to the Purchasing Division prior to Contract award.

In lieu of the Bid Bond, Performance Bond, and Labor/Material Payment Bond, the Vendor may provide certified checks, cashier's checks, or irrevocable letters of credit. Any certified check, cashier's check, or irrevocable letter of credit provided in lieu of a bond must be of the same amount and delivered on the same schedule as the bond it replaces. A letter of credit submitted in lieu of a performance and labor/material payment bond will only be allowed for projects under \$100,000. Personal or business checks are not acceptable. Notwithstanding the foregoing, West Virginia Code § 5-22-1 (d) mandates that a vendor provide a performance and labor/material payment bond for construction projects. Accordingly, substitutions for the performance and labor/material payment bonds for construction projects is not permitted.

MAINTENANCE BOND: The apparent successful Vendor shall provide a two (2) year maintenance bond covering the roofing system. The maintenance bond must be issued and delivered to the Purchasing Division prior to Contract award.

LICENSE(S) / CERTIFICATIONS / PERMITS: In addition to anything required under the Section of the General Terms and Conditions entitled Licensing, the apparent successful Vendor shall furnish proof of the following licenses, certifications, and/or permits prior to Contract award, in a form acceptable to the Purchasing Division.

The apparent successful Vendor shall also furnish proof of any additional licenses or certifications contained in the specifications prior to Contract award regardless of whether or not that requirement is listed above.

8. INSURANCE: The apparent successful Vendor shall furnish proof of the insurance identified by a checkmark below and must include the State as an additional insured on each policy prior to Contract award. The insurance coverages identified below must be maintained throughout the life of this contract. Thirty (30) days prior to the expiration of the insurance policies, Vendor shall provide the Agency with proof that the insurance mandated herein has been continued. Vendor must also provide Agency with immediate notice of any changes in its insurance policies, including but not limited to, policy cancelation, policy reduction, or change in insurers. The apparent successful Vendor shall also furnish proof of any additional insurance requirements contained in the specifications prior to Contract award regardless of whether or not that insurance requirement is listed in this section.

Vendor must maintain:

- Commercial General Liability Insurance** in at least an amount of: \$ 1,000,000***SEE BELOW per occurrence.
- Automobile Liability Insurance** in at least an amount of: \$ 1,000,000.00 per occurrence.
- Professional/Malpractice/Errors and Omission Insurance** in at least an amount of: _____ per occurrence. Notwithstanding the forgoing, Vendor's are not required to list the State as an additional insured for this type of policy.
- Commercial Crime and Third Party Fidelity Insurance** in an amount of: _____ per occurrence.
- Cyber Liability Insurance** in an amount of: _____ per occurrence.
- Builders Risk Insurance** in an amount equal to 100% of the amount of the Contract.
- Pollution Insurance** in an amount of: _____ per occurrence.
- Aircraft Liability** in an amount of: _____ per occurrence.
- **STATE OF WV MUST BE LISTED AS ADDITIONAL INSURED ON INSURANCE CERTIFICATE.****
- **CERTIFICATE HOLDER SHOULD READ AS FOLLOWS:**
STATE OF WV
1900 KANAWHA BLVD E - BUILDING 5, CHARLESTON, WV 25305
-
-

Notwithstanding anything contained in this section to the contrary, the Director of the Purchasing Division reserves the right to waive the requirement that the State be named as an additional insured on one or more of the Vendor's insurance policies if the Director finds that doing so is in the State's best interest.

9. WORKERS' COMPENSATION INSURANCE: The apparent successful Vendor shall comply with laws relating to workers compensation, shall maintain workers' compensation insurance when required, and shall furnish proof of workers' compensation insurance upon request.

10. [Reserved]

11. LIQUIDATED DAMAGES: This clause shall in no way be considered exclusive and shall not limit the State or Agency's right to pursue any other available remedy. Vendor shall pay liquidated damages in the amount specified below or as described in the specifications:

_____ for _____

Liquidated Damages Contained in the Specifications

12. ACCEPTANCE: Vendor's signature on its bid, or on the certification and signature page, constitutes an offer to the State that cannot be unilaterally withdrawn, signifies that the product or service proposed by vendor meets the mandatory requirements contained in the Solicitation for that product or service, unless otherwise indicated, and signifies acceptance of the terms and conditions contained in the Solicitation unless otherwise indicated.

13. PRICING: The pricing set forth herein is firm for the life of the Contract, unless specified elsewhere within this Solicitation/Contract by the State. A Vendor's inclusion of price adjustment provisions in its bid, without an express authorization from the State in the Solicitation to do so, may result in bid disqualification. Notwithstanding the foregoing, Vendor must extend any publicly advertised sale price to the State and invoice at the lower of the contract price or the publicly advertised sale price.

14. PAYMENT IN ARREARS: Payment in advance is prohibited under this Contract. Payment may only be made after the delivery and acceptance of goods or services. The Vendor shall submit invoices, in arrears.

15. PAYMENT METHODS: Vendor must accept payment by electronic funds transfer and P-Card. (The State of West Virginia's Purchasing Card program, administered under contract by a banking institution, processes payment for goods and services through state designated credit cards.)

16. TAXES: The Vendor shall pay any applicable sales, use, personal property or any other taxes arising out of this Contract and the transactions contemplated thereby. The State of West Virginia is exempt from federal and state taxes and will not pay or reimburse such taxes.

17. ADDITIONAL FEES: Vendor is not permitted to charge additional fees or assess additional charges that were not either expressly provided for in the solicitation published by the State of West Virginia or included in the unit price or lump sum bid amount that Vendor is required by the solicitation to provide. Including such fees or charges as notes to the solicitation may result in rejection of vendor's bid. Requesting such fees or charges be paid after the contract has been awarded may result in cancellation of the contract.

18. FUNDING: This Contract shall continue for the term stated herein, contingent upon funds being appropriated by the Legislature or otherwise being made available. In the event funds are not appropriated or otherwise made available, this Contract becomes void and of no effect beginning on July 1 of the fiscal year for which funding has not been appropriated or otherwise made available.

19. CANCELLATION: The Purchasing Division Director reserves the right to cancel this Contract immediately upon written notice to the vendor if the materials or workmanship supplied do not conform to the specifications contained in the Contract. The Purchasing Division Director may also cancel any purchase or Contract upon 30 days written notice to the Vendor in accordance with West Virginia Code of State Rules § 148-1-5.2.b.

20. TIME: Time is of the essence with regard to all matters of time and performance in this Contract.

21. APPLICABLE LAW: This Contract is governed by and interpreted under West Virginia law without giving effect to its choice of law principles. Any information provided in specification manuals, or any other source, verbal or written, which contradicts or violates the West Virginia Constitution, West Virginia Code or West Virginia Code of State Rules is void and of no effect.

22. COMPLIANCE WITH LAWS: Vendor shall comply with all applicable federal, state, and local laws, regulations and ordinances. By submitting a bid, Vendor acknowledges that it has reviewed, understands, and will comply with all applicable laws, regulations, and ordinances.

SUBCONTRACTOR COMPLIANCE: Vendor shall notify all subcontractors providing commodities or services related to this Contract that as subcontractors, they too are required to comply with all applicable laws, regulations, and ordinances. Notification under this provision must occur prior to the performance of any work under the contract by the subcontractor.

23. ARBITRATION: Any references made to arbitration contained in this Contract, Vendor's bid, or in any American Institute of Architects documents pertaining to this Contract are hereby deleted, void, and of no effect.

24. MODIFICATIONS: This writing is the parties' final expression of intent. Notwithstanding anything contained in this Contract to the contrary no modification of this Contract shall be binding without mutual written consent of the Agency, and the Vendor, with approval of the Purchasing Division and the Attorney General's office (Attorney General approval is as to form only). Any change to existing contracts that adds work or changes contract cost, and were not included in the original contract, must be approved by the Purchasing Division and the Attorney General's Office (as to form) prior to the implementation of the change or commencement of work affected by the change.

25. WAIVER: The failure of either party to insist upon a strict performance of any of the terms or provision of this Contract, or to exercise any option, right, or remedy herein contained, shall not be construed as a waiver or a relinquishment for the future of such term, provision, option, right, or remedy, but the same shall continue in full force and effect. Any waiver must be expressly stated in writing and signed by the waiving party.

26. SUBSEQUENT FORMS: The terms and conditions contained in this Contract shall supersede any and all subsequent terms and conditions which may appear on any form documents submitted by Vendor to the Agency or Purchasing Division such as price lists, order forms, invoices, sales agreements, or maintenance agreements, and includes internet websites or other electronic documents. Acceptance or use of Vendor's forms does not constitute acceptance of the terms and conditions contained thereon.

27. ASSIGNMENT: Neither this Contract nor any monies due, or to become due hereunder, may be assigned by the Vendor without the express written consent of the Agency, the Purchasing Division, the Attorney General's office (as to form only), and any other government agency or office that may be required to approve such assignments.

28. WARRANTY: The Vendor expressly warrants that the goods and/or services covered by this Contract will: (a) conform to the specifications, drawings, samples, or other description furnished or specified by the Agency; (b) be merchantable and fit for the purpose intended; and (c) be free from defect in material and workmanship.

29. STATE EMPLOYEES: State employees are not permitted to utilize this Contract for personal use and the Vendor is prohibited from permitting or facilitating the same.

30. PRIVACY, SECURITY, AND CONFIDENTIALITY: The Vendor agrees that it will not disclose to anyone, directly or indirectly, any such personally identifiable information or other confidential information gained from the Agency, unless the individual who is the subject of the information consents to the disclosure in writing or the disclosure is made pursuant to the Agency's policies, procedures, and rules. Vendor further agrees to comply with the Confidentiality Policies and Information Security Accountability Requirements, set forth in <http://www.state.wv.us/admin/purchase/privacy/default.html>.

31. YOUR SUBMISSION IS A PUBLIC DOCUMENT: Vendor's entire response to the Solicitation and the resulting Contract are public documents. As public documents, they will be disclosed to the public following the bid/proposal opening or award of the contract, as required by the competitive bidding laws of West Virginia Code §§ 5A-3-1 et seq., 5-22-1 et seq., and 5G-1-1 et seq. and the Freedom of Information Act West Virginia Code §§ 29B-1-1 et seq.

DO NOT SUBMIT MATERIAL YOU CONSIDER TO BE CONFIDENTIAL, A TRADE SECRET, OR OTHERWISE NOT SUBJECT TO PUBLIC DISCLOSURE.

Submission of any bid, proposal, or other document to the Purchasing Division constitutes your explicit consent to the subsequent public disclosure of the bid, proposal, or document. The Purchasing Division will disclose any document labeled "confidential," "proprietary," "trade secret," "private," or labeled with any other claim against public disclosure of the documents, to include any "trade secrets" as defined by West Virginia Code § 47-22-1 et seq. All submissions are subject to public disclosure without notice.

32. LICENSING: In accordance with West Virginia Code of State Rules § 148-1-6.1.e, Vendor must be licensed and in good standing in accordance with any and all state and local laws and requirements by any state or local agency of West Virginia, including, but not limited to, the West Virginia Secretary of State's Office, the West Virginia Tax Department, West Virginia Insurance Commission, or any other state agency or political subdivision. Obligations related to political subdivisions may include, but are not limited to, business licensing, business and occupation taxes, inspection compliance, permitting, etc. Upon request, the Vendor must provide all necessary releases to obtain information to enable the Purchasing Division Director or the Agency to verify that the Vendor is licensed and in good standing with the above entities.

SUBCONTRACTOR COMPLIANCE: Vendor shall notify all subcontractors providing commodities or services related to this Contract that as subcontractors, they too are required to be licensed, in good standing, and up-to-date on all state and local obligations as described in this section. Obligations related to political subdivisions may include, but are not limited to, business licensing, business and occupation taxes, inspection compliance, permitting, etc. Notification under this provision must occur prior to the performance of any work under the contract by the subcontractor.

33. ANTITRUST: In submitting a bid to, signing a contract with, or accepting a Award Document from any agency of the State of West Virginia, the Vendor agrees to convey, sell, assign, or transfer to the State of West Virginia all rights, title, and interest in and to all causes of action it may now or hereafter acquire under the antitrust laws of the United States and the State of West Virginia for price fixing and/or unreasonable restraints of trade relating to the particular commodities or services purchased or acquired by the State of West Virginia. Such assignment shall be made and become effective at the time the purchasing agency tenders the initial payment to Vendor.

34. VENDOR CERTIFICATIONS: By signing its bid or entering into this Contract, Vendor certifies (1) that its bid or offer was made without prior understanding, agreement, or connection with any corporation, firm, limited liability company, partnership, person or entity submitting a bid or offer for the same material, supplies, equipment or services; (2) that its bid or offer is in all respects fair and without collusion or fraud; (3) that this Contract is accepted or entered into without any prior understanding, agreement, or connection to any other entity that could be considered a violation of law; and (4) that it has reviewed this Solicitation in its entirety; understands the requirements, terms and conditions, and other information contained herein.

Vendor's signature on its bid or offer also affirms that neither it nor its representatives have any interest, nor shall acquire any interest, direct or indirect, which would compromise the performance of its services hereunder. Any such interests shall be promptly presented in detail to the Agency. The individual signing this bid or offer on behalf of Vendor certifies that he or she is authorized by the Vendor to execute this bid or offer or any documents related thereto on Vendor's behalf; that he or she is authorized to bind the Vendor in a contractual relationship; and that, to the best of his or her knowledge, the Vendor has properly registered with any State agency that may require registration.

35. VENDOR RELATIONSHIP: The relationship of the Vendor to the State shall be that of an independent contractor and no principal-agent relationship or employer-employee relationship is contemplated or created by this Contract. The Vendor as an independent contractor is solely liable for the acts and omissions of its employees and agents. Vendor shall be responsible for selecting, supervising, and compensating any and all individuals employed pursuant to the terms of this Solicitation and resulting contract. Neither the Vendor, nor any employees or subcontractors of the Vendor, shall be deemed to be employees of the State for any purpose whatsoever. Vendor shall be exclusively responsible for payment of employees and contractors for all wages and salaries, taxes, withholding payments, penalties, fees, fringe benefits, professional liability insurance premiums, contributions to insurance and pension, or other deferred compensation plans, including but not limited to, Workers' Compensation and Social Security obligations, licensing fees, etc. and the filing of all necessary documents, forms, and returns pertinent to all of the foregoing.

Vendor shall hold harmless the State, and shall provide the State and Agency with a defense against any and all claims including, but not limited to, the foregoing payments, withholdings, contributions, taxes, Social Security taxes, and employer income tax returns.

36. INDEMNIFICATION: The Vendor agrees to indemnify, defend, and hold harmless the State and the Agency, their officers, and employees from and against: (1) Any claims or losses for services rendered by any subcontractor, person, or firm performing or supplying services, materials, or supplies in connection with the performance of the Contract; (2) Any claims or losses resulting to any person or entity injured or damaged by the Vendor, its officers, employees, or subcontractors by the publication, translation, reproduction, delivery, performance, use, or disposition of any data used under the Contract in a manner not authorized by the Contract, or by Federal or State statutes or regulations; and (3) Any failure of the Vendor, its officers, employees, or subcontractors to observe State and Federal laws including, but not limited to, labor and wage and hour laws.

37. PURCHASING AFFIDAVIT: In accordance with West Virginia Code §§ 5A-3-10a and 5-22-1(i), the State is prohibited from awarding a contract to any bidder that owes a debt to the State or a political subdivision of the State, Vendors are required to sign, notarize, and submit the Purchasing Affidavit to the Purchasing Division affirming under oath that it is not in default on any monetary obligation owed to the state or a political subdivision of the state.

38. ADDITIONAL AGENCY AND LOCAL GOVERNMENT USE: This Contract may be utilized by other agencies, spending units, and political subdivisions of the State of West Virginia; county, municipal, and other local government bodies; and school districts (“Other Government Entities”), provided that both the Other Government Entity and the Vendor agree. Any extension of this Contract to the aforementioned Other Government Entities must be on the same prices, terms, and conditions as those offered and agreed to in this Contract, provided that such extension is in compliance with the applicable laws, rules, and ordinances of the Other Government Entity. A refusal to extend this Contract to the Other Government Entities shall not impact or influence the award of this Contract in any manner.

39. CONFLICT OF INTEREST: Vendor, its officers or members or employees, shall not presently have or acquire an interest, direct or indirect, which would conflict with or compromise the performance of its obligations hereunder. Vendor shall periodically inquire of its officers, members and employees to ensure that a conflict of interest does not arise. Any conflict of interest discovered shall be promptly presented in detail to the Agency.

40. REPORTS: Vendor shall provide the Agency and/or the Purchasing Division with the following reports identified by a checked box below:

Such reports as the Agency and/or the Purchasing Division may request. Requested reports may include, but are not limited to, quantities purchased, agencies utilizing the contract, total contract expenditures by agency, etc.

Quarterly reports detailing the total quantity of purchases in units and dollars, along with a listing of purchases by agency. Quarterly reports should be delivered to the Purchasing Division via email at purchasing.requisitions@wv.gov.

41. BACKGROUND CHECK: In accordance with W. Va. Code § 15-2D-3, the Director of the Division of Protective Services shall require any service provider whose employees are regularly employed on the grounds or in the buildings of the Capitol complex or who have access to sensitive or critical information to submit to a fingerprint-based state and federal background inquiry through the state repository. The service provider is responsible for any costs associated with the fingerprint-based state and federal background inquiry.

After the contract for such services has been approved, but before any such employees are permitted to be on the grounds or in the buildings of the Capitol complex or have access to sensitive or critical information, the service provider shall submit a list of all persons who will be physically present and working at the Capitol complex to the Director of the Division of Protective Services for purposes of verifying compliance with this provision. The State reserves the right to prohibit a service provider’s employees from accessing sensitive or critical information or to be present at the Capitol complex based upon results addressed from a criminal background check.

Revised 10/01/2019

Service providers should contact the West Virginia Division of Protective Services by phone at (304) 558-9911 for more information.

42. PREFERENCE FOR USE OF DOMESTIC STEEL PRODUCTS: Except when authorized by the Director of the Purchasing Division pursuant to W. Va. Code § 5A-3-56, no contractor may use or supply steel products for a State Contract Project other than those steel products made in the United States. A contractor who uses steel products in violation of this section may be subject to civil penalties pursuant to W. Va. Code § 5A-3-56. As used in this section:

- a. "State Contract Project" means any erection or construction of, or any addition to, alteration of or other improvement to any building or structure, including, but not limited to, roads or highways, or the installation of any heating or cooling or ventilating plants or other equipment, or the supply of and materials for such projects, pursuant to a contract with the State of West Virginia for which bids were solicited on or after June 6, 2001.
- b. "Steel Products" means products rolled, formed, shaped, drawn, extruded, forged, cast, fabricated or otherwise similarly processed, or processed by a combination of two or more or such operations, from steel made by the open heath, basic oxygen, electric furnace, Bessemer or other steel making process. The Purchasing Division Director may, in writing, authorize the use of foreign steel products if:
- c. The cost for each contract item used does not exceed one tenth of one percent (.1%) of the total contract cost or two thousand five hundred dollars (\$2,500.00), whichever is greater. For the purposes of this section, the cost is the value of the steel product as delivered to the project; or
- d. The Director of the Purchasing Division determines that specified steel materials are not produced in the United States in sufficient quantity or otherwise are not reasonably available to meet contract requirements.

43. PREFERENCE FOR USE OF DOMESTIC ALUMINUM, GLASS, AND STEEL: In Accordance with W. Va. Code § 5-19-1 et seq., and W. Va. CSR § 148-10-1 et seq., for every contract or subcontract, subject to the limitations contained herein, for the construction, reconstruction, alteration, repair, improvement or maintenance of public works or for the purchase of any item of machinery or equipment to be used at sites of public works, only domestic aluminum, glass or steel products shall be supplied unless the spending officer determines, in writing, after the receipt of offers or bids, (1) that the cost of domestic aluminum, glass or steel products is unreasonable or inconsistent with the public interest of the State of West Virginia, (2) that domestic aluminum, glass or steel products are not produced in sufficient quantities to meet the contract requirements, or (3) the available domestic aluminum, glass, or steel do not meet the contract specifications. This provision only applies to public works contracts awarded in an amount more than fifty thousand dollars (\$50,000) or public works contracts that require more than ten thousand pounds of steel products.

The cost of domestic aluminum, glass, or steel products may be unreasonable if the cost is more than twenty percent (20%) of the bid or offered price for foreign made aluminum, glass, or steel products. If the domestic aluminum, glass or steel products to be supplied or produced in a

“substantial labor surplus area”, as defined by the United States Department of Labor, the cost of domestic aluminum, glass, or steel products may be unreasonable if the cost is more than thirty percent (30%) of the bid or offered price for foreign made aluminum, glass, or steel products. This preference shall be applied to an item of machinery or equipment, as indicated above, when the item is a single unit of equipment or machinery manufactured primarily of aluminum, glass or steel, is part of a public works contract and has the sole purpose or of being a permanent part of a single public works project. This provision does not apply to equipment or machinery purchased by a spending unit for use by that spending unit and not as part of a single public works project.

All bids and offers including domestic aluminum, glass or steel products that exceed bid or offer prices including foreign aluminum, glass or steel products after application of the preferences provided in this provision may be reduced to a price equal to or lower than the lowest bid or offer price for foreign aluminum, glass or steel products plus the applicable preference. If the reduced bid or offer prices are made in writing and supersede the prior bid or offer prices, all bids or offers, including the reduced bid or offer prices, will be reevaluated in accordance with this rule.

44. INTERESTED PARTY SUPPLEMENTAL DISCLOSURE: W. Va. Code § 6D-1-2 requires that for contracts with an actual or estimated value of at least \$1 million, the vendor must submit to the Agency a supplemental disclosure of interested parties reflecting any new or differing interested parties to the contract, which were not included in the original pre-award interested party disclosure, within 30 days following the completion or termination of the contract. A copy of that form is included with this solicitation or can be obtained from the WV Ethics Commission. This requirement does not apply to publicly traded companies listed on a national or international stock exchange. A more detailed definition of interested parties can be obtained from the form referenced above.



Purchasing Division
 2019 Washington Street East
 Post Office Box 50130
 Charleston, WV 25305-0130

State of West Virginia
 Request for Quotation
 19 - Highways

Proc Folder: 642516

Doc Description: ADDENDUM 2 TIRE AND CROSS CHAINS. COMP/ACCESS. (7020C004)

Proc Type: Central Master Agreement

Date Issued	Solicitation Closes	Solicitation No	Version
2019-12-19	2019-12-23 13:30:00	CRFQ 0803 DOT2000000070	3

BID RECEIVING LOCATION

BID CLERK
 DEPARTMENT OF ADMINISTRATION
 PURCHASING DIVISION
 2019 WASHINGTON ST E
 CHARLESTON WV 25305
 US

VENDOR

Vendor Name, Address and Telephone Number:

Pewag TRACTION Chain INC.
190 Greenhorn Drive
Pueblo, CO 81004
719-623-5700

FOR INFORMATION CONTACT THE BUYER

Crystal G Husted
 (304) 558-2402
 crystal.g.husted@wv.gov

Signature X

FEIN # 461549724

DATE 12/19/2019

All offers subject to all terms and conditions contained in this solicitation

DOT2000000070	Document Phase Final	Document Description ADDENDUM 2 TIRE AND CROSS CHAINS, COMP/ACCESS. (7020C004)	Page 3 of 3
---------------	--------------------------------	---	-----------------------

ADDITIONAL TERMS AND CONDITIONS

See attached document(s) for additional Terms and Conditions

SOLICITATION NUMBER: CRFQ DOT2000000070
Addendum Number: 1

The purpose of this addendum is to modify the solicitation identified as ("Solicitation") to reflect the change(s) identified and described below.

Applicable Addendum Category:

- Modify bid opening date and time
- Modify specifications of product or service being sought
- Attachment of vendor questions and responses
- Attachment of pre-bid sign-in sheet
- Correction of error
- Other

Description of Modification to Solicitation:

1. To extend bid opening to December 23, 2019 at 1:30 PM
2. To provide clarification to vendor question

No other changes

Additional Documentation: Documentation related to this Addendum (if any) has been included herewith as Attachment A and is specifically incorporated herein by reference.

Terms and Conditions:

1. All provisions of the Solicitation and other addenda not modified herein shall remain in full force and effect.
2. Vendor should acknowledge receipt of all addenda issued for this Solicitation by completing an Addendum Acknowledgment, a copy of which is included herewith. Failure to acknowledge addenda may result in bid disqualification. The addendum acknowledgement should be submitted with the bid to expedite document processing.

ADDENDUM ACKNOWLEDGEMENT FORM
SOLICITATION NO.: DOT2000000070

Instructions: Please acknowledge receipt of all addenda issued with this solicitation by completing this addendum acknowledgment form. Check the box next to each addendum received and sign below. Failure to acknowledge addenda may result in bid disqualification.

Acknowledgment: I hereby acknowledge receipt of the following addenda and have made the necessary revisions to my proposal, plans and/or specification, etc.

Addendum Numbers Received:

(Check the box next to each addendum received)

- | | |
|--|--|
| <input checked="" type="checkbox"/> Addendum No. 1 | <input type="checkbox"/> Addendum No. 6 |
| <input checked="" type="checkbox"/> Addendum No. 2 | <input type="checkbox"/> Addendum No. 7 |
| <input type="checkbox"/> Addendum No. 3 | <input type="checkbox"/> Addendum No. 8 |
| <input type="checkbox"/> Addendum No. 4 | <input type="checkbox"/> Addendum No. 9 |
| <input type="checkbox"/> Addendum No. 5 | <input type="checkbox"/> Addendum No. 10 |

I understand that failure to confirm the receipt of addenda may be cause for rejection of this bid. I further understand that any verbal representation made or assumed to be made during any oral discussion held between Vendor's representatives and any state personnel is not binding. Only the information issued in writing and added to the specifications by an official addendum is binding.

Pewag TRACTION CHAIN, INC.
Company

Authorized Signature

12/19/19
Date

NOTE: This addendum acknowledgment should be submitted with the bid to expedite document processing.
Revised 6/9/2012

ADDENDUM 2

CRFQ DOT200000070

TIRE AND CROSS CHAINS, COMPONENTS & ACCESSORIES

- 1. Question: Question 7 is a misleading question and I believe the answer is incorrect. 7mm cross chain min wire diameter and 6mm side chain min wire diameter does it apply to wheel sizes under 22"??**
Answer- yes. All wheel sizes "above 20" are considered heavy truck applications and require 7mm cross and 6mm side. However light truck applications such at 19.5, 17.5 and 16 all require light truck applications of 5.6 or smaller. Standard light truck chain is 5.6mm under the guidelines and 7mm would be considered a special build and a higher price? Please clarify.

Answer: Chains below 20-inch wheel size shall be 5.6mm diameter.



Purchasing Division
 2019 Washington Street East
 Post Office Box 50130
 Charleston, WV 25305-0130

State of West Virginia
 Request for Quotation
 19 - Highways

Proc Folder: 642516

Doc Description: ADDEDUM 1 TIRE AND CROSS CHAINS, COMPIACCESS. (7020C004)

Proc Type: Central Master Agreement

Date Issued	Solicitation Closes	Solicitation No	Version
2019-12-12	2019-12-19 13:30:00	CRFQ 0803 DOT2000000070	2

BID RECEIVING LOCATION

BID CLERK

DEPARTMENT OF ADMINISTRATION

PURCHASING DIVISION

2019 WASHINGTON ST E

CHARLESTON

WV 25305

US

VENDOR

Vendor Name, Address and Telephone Number:

Pewag Traction CHAIN INC.

190 GREENHORN DRIVE

Pueblo.CO 81004

719-623-5700

FOR INFORMATION CONTACT THE BUYER

Crystal G Husted

(304) 558-2402

crystal.g.husted@wv.gov

Signature X

FEIN # *461549724*

DATE *12/18/2019*

All offers subject to all terms and conditions contained in this solicitation

DOT2000000070	Document Phase Final	Document Description ADDEDUM 1 TIRE AND CROSS CHAINS, COMP/ACCESS. (7020C004)	Page 3 of 3
---------------	--------------------------------	--	-----------------------

ADDITIONAL TERMS AND CONDITIONS

See attached document(s) for additional Terms and Conditions

SOLICITATION NUMBER: CRFQ DOT2000000070

Addendum Number: 1

The purpose of this addendum is to modify the solicitation identified as ("Solicitation") to reflect the change(s) identified and described below.

Applicable Addendum Category:

- Modify bid opening date and time
- Modify specifications of product or service being sought
- Attachment of vendor questions and responses
- Attachment of pre-bid sign-in sheet
- Correction of error
- Other

Description of Modification to Solicitation:

1. To provide answers to vendor questions
2. To publish the mandatory pre-bid meeting sign-in sheets

No other changes

Bid opening remains December 19, 2019 at 1:30 PM

Additional Documentation: Documentation related to this Addendum (if any) has been included herewith as Attachment A and is specifically incorporated herein by reference.

Terms and Conditions:

1. All provisions of the Solicitation and other addenda not modified herein shall remain in full force and effect.
2. Vendor should acknowledge receipt of all addenda issued for this Solicitation by completing an Addendum Acknowledgment, a copy of which is included herewith. Failure to acknowledge addenda may result in bid disqualification. The addendum acknowledgement should be submitted with the bid to expedite document processing.

ADDENDUM ACKNOWLEDGEMENT FORM
SOLICITATION NO.: CRFQ DOT200000070

Instructions: Please acknowledge receipt of all addenda issued with this solicitation by completing this addendum acknowledgment form. Check the box next to each addendum received and sign below. Failure to acknowledge addenda may result in bid disqualification.

Acknowledgment: I hereby acknowledge receipt of the following addenda and have made the necessary revisions to my proposal, plans and/or specification, etc.

Addendum Numbers Received:

(Check the box next to each addendum received)

- | | |
|--|--|
| <input checked="" type="checkbox"/> Addendum No. 1 | <input type="checkbox"/> Addendum No. 6 |
| <input type="checkbox"/> Addendum No. 2 | <input type="checkbox"/> Addendum No. 7 |
| <input type="checkbox"/> Addendum No. 3 | <input type="checkbox"/> Addendum No. 8 |
| <input type="checkbox"/> Addendum No. 4 | <input type="checkbox"/> Addendum No. 9 |
| <input type="checkbox"/> Addendum No. 5 | <input type="checkbox"/> Addendum No. 10 |

I understand that failure to confirm the receipt of addenda may be cause for rejection of this bid. I further understand that any verbal representation made or assumed to be made during any oral discussion held between Vendor's representatives and any state personnel is not binding. Only the information issued in writing and added to the specifications by an official addendum is binding.

pewag Traction Chain, Inc

Company

Authorized Signature

December 12, 2019

Date

NOTE: This addendum acknowledgment should be submitted with the bid to expedite document processing.

ATTACHMENT A

Revised 6/8/2012



ADDENDUM 1

CRFQ DOT200000070

TIRE AND CROSS CHAINS, COMPONENTS & ACCESSORIES

1. **Question:** Based on past bids I have a few questions which I have attached. The purpose of the questions are to determine the MM sizes of the Equipment chain. It is offered in several sizes. 8.2mm, 10mm, 12mm.

Q: Line Item 2 (14.00 x 24/Net) 8.2mm, 10mm, 12mm?

A: Line Item 2 shall be 10mm.

Q: Line Item 4 (14.00 x 24 2-link) truck chain?

A: Line Item 4 shall be Grader chain.

Q: Line Item 5 (15.5 x 25 loader) 10mm, 12mm?

A: Line Item 5 shall be 10mm.

Q: Line Item 7 (17.5 x 25 loader) 10mm, 12mm?

A: Line Item 7 shall be 10mm.

Q: Line Item 12 (14.00 x 24) Loader and mm?

A: Line Item 12 shall be Loader 10mm.

Q: Line Item 13 (14.00 x 24 ladder) Truck chain?

A: Line Item 13 shall be Loader 10mm.

Q: Line Item 14 (225/75-19.5 zigzag) 5.6 or 7mm?

A: Line Item 14 shall be 7mm.

Q: Line Item 15 (245/75.19.5zigzag) 5.6 or 7mm?

A: Line Item 15 shall be 7mm.

2. **Question:** Do the items in this solicitation qualify for the US Steel preference? Section 43 paragraph 2 of the General Terms and Conditions in the document Complete Solicitation Documents states, "This provision does not apply to equipment or machinery purchased by a spending unit for use by that spending unit and not as part of a single public works project."

A: US Steel preference will follow WV code 5-19-1 et seq and WV CSR 148-10-1 et seq.

ADDENDUM 1

CRFQ DOT2000000070

TIRE AND CROSS CHAINS, COMPONENTS & ACCESSORIES

3. **Question:** Does the pricing catalog have to be a printed price catalog used by all customers or can it be in a different format? Excel, Word Document?

A: Pricing Catalog must be the full product line and can be in Excel or Word document. If submitting Excel or Word document, please see that the document is searchable by the Agency.

4. **Question:** ISO 9001 and ISO 14001 does it need to be supplied with the Bid? And it must be provided by the manufacturer of the chains, not the vendor or supplier.

A: Yes, supplied with the bid and must be provided by the chain manufacturer.

5. **Question:** Does all Specification sheets for material make up need to accompany the Bid?

A: Yes.

6. **Question:** Are cams required for grader and loader chains?

A: Not required but will accept with or without.

7. **Question:** Does 7mm Cross Chain min wire dia. And 6mm Side chain min wire dia. Apply to wheel sizes under 22".

A: Yes.

8. **Question:** Are cams required on Zigzag chains?

A: Yes, cams are required on Zigzag chains.

Pre-Bid Sign-In Sheet

Solicitation Number: CRFQ 0803 DOT2000000070

Date of Pre-Bid Meeting: December 4, 2019

Location of Prebid Meeting: Buckhannon, WV Equip. Div.

Please Note:

Vendors must sign-in on this sheet to verify attendance at the Pre-Bid meeting.
 Failure to legibly sign in may be grounds for declaring a vendor ineligible to bid.
 For further verification, please also provide a business card if possible.

<u>Firm Represented:*</u>	<u>Rep Name (Printed):</u>	<u>Firm Address:</u>	<u>Telephone #:</u>	<u>Fax #:</u>	<u>Email:</u>
PEWAG	TAMMY KNIGHT	Pewab Traktion 190 Grechorn Dr. Pueblo, CO 81004	304-641-3132	866-472-8775	tammy.knight@pewag.com tammy.k@pewagchain.com
VMP	Ben McKinney	Vehicle maintenance Program 3595 N. Dixie Hwy #7 Boca Raton, FL 33431	561 362 6080	561 362 7994	sales@vmpparts.com

***One Vendor Per Representative - No one individual is permitted to represent more than one vendor at the pre-bid meeting. Any individual that does attempt to represent two or more vendors will be required to select one vendor to which the individual's attendance will be attributed. The vendors not selected will be deemed to have not attended the pre-bid meeting unless another individual attended on their behalf.**

Pre-Bid Sign-In Sheet

Solicitation Number: CRFQ 0803 DOT2000000070

Date of Pre-Bid Meeting: December 4, 2019

Location of Prebid Meeting: Buckhannon, WV Equip. Div.

Please Note:

Vendors must sign-in on this sheet to verify attendance at the Pre-Bid meeting.
 Failure to legibly sign in may be grounds for declaring a vendor ineligible to bid.
 For further verification, please also provide a business card if possible.

<u>Firm Represented:*</u>	<u>Rep Name (Printed):</u>	<u>Firm Address:</u>	<u>Telephone #:</u>	<u>Fax #:</u>	<u>Email:</u>
WVDOH	JD Haller				
WVDOH	Tammy Cleverger				
WV DOH	Tina Lewis				

**One Vendor Per Representative - No one individual is permitted to represent more than one vendor at the pre-bid meeting. Any individual that does attempt to represent two or more vendors will be required to select one vendor to which the individual's attendance will be attributed. The vendors not selected will be deemed to have not attended the pre-bid meeting unless another individual attended on their behalf.*

pewäg

**STRONG
IS NOT
ENOUGH**
www.pewag.com

pewag Inc. USA
3825 Cincinnati Ave., Suite D
Rocklin, CA 95765
Phone: (800) 445-2885
Fax: (888) 472-8775
Cell: (504) 641-3132
tammyk@pewagchain.com
www.pewagchain.com

Tammy Knight
Eastern Sales Manager - Traction Chain Division

VENDOR: pewag Traction Chain, Inc TIRE & CROSS CHAIN, COMPONENTS & ACCESSORIES - Pricing Page

Discount Percentage** -65.00% (Please enter as a negative. Example discount of 5% should be -5.0%)

Markup Percentage** 0.00%

Item No.	OEM Part number	"Or Equal" Parts	Estimated Unit Quantity	Unit (for calculation purposes)	Catalog Unit Price	Units Provided for Catalog Price	**Discount/Markup** Percentage	Adjusted Unit Price	Item Total Cost
1	Part No. 245/75r17 Description: Tire chain	Part No. USA 3210 SC Description: 5.6mm Square	200	1 EA	\$ 372.81	1.00	-65.00%	\$ 130.48	\$130.48
2	Part No. 14.00x24 2-link Description: Tire chain	Part No. USA 2615 S 10mm DS Description: 10 mm Square	100	1 EA	\$ 2,400.00	1.00	-65.00%	\$ 840.00	\$840.00
3	Part No. 245/70r17 Description: Tire chain	Part No. USA 3210 SC Description: 5.6mm Square	200	1 EA	\$ 372.81	1.00	-65.00%	\$ 130.48	\$130.48
4	Part No. 14.00x24 Net Description: Tire chain	Part No. 69155 Description: 10mm Square	100	1 EA	\$ 3,785.72	1.00	-65.00%	\$ 1,325.00	\$1,325.00
5	Part No. 15.5x25 loader Description: Tire chain	Part No. USA 2612 S 10mm Description: 10mm Square	200	1 EA	\$ 1,187.77	1.00	-65.00%	\$ 415.72	\$415.72
6	Part No. 11r22.5 Description: Tire chain	Part No. USA 2247 SC Description: 7mm Square	150	1 EA	\$ 393.28	1.00	-65.00%	\$ 137.65	\$137.65
7	Part No. 17.5x25 loader Description: Tire chain	Part No. USA 2624 S 10mm Description: 10mm Square	300	1 EA	\$ 1,610.00	1.00	-65.00%	\$ 563.50	\$563.50
8	Part No. 225/70r19.5 Description: Tire chain	Part No. USA 2221 SC Description: 5.6mm Square	250	1 EA	\$ 377.48	1.00	-65.00%	\$ 132.12	\$132.12

Item No.	OEM Part number	"Or Equal" Parts	Estimated Unit Quantity	Unit (for calculation purposes)	Catalog Unit Price	Units Provided for Catalog Price	**Discount/Markup** Percentage	Adjusted Unit Price	Item Total Cost
9	Part No. 245/70r19.5 ladder Description: Tire chain	Part No. USA 2228 SC Description: 5.6mm Square	250	1 EA	\$ 400.24	1.00	-65.00%	\$ 140.08	\$140.08
10	Part No. 235/75r16 Description: Tire chain	Part No. USA 2219 SC Description: 5.6mm Square	300	1 EA	\$ 362.53	1.00	-65.00%	\$ 126.89	\$126.89
11	Part No. 245/75r16 Description: Tire chain	Part No. USA 2221 SC Description: 5.6mm Square	300	1 EA	\$ 377.48	1.00	-65.00%	\$ 132.12	\$132.12
12	Part No. 14.00x24 Description: Tire chain	Part No. USA 2615 S 10mm Description: 10mm Square	100	1 EA	\$ 1,355.14	1.00	-65.00%	\$ 474.30	\$474.30
13	Part No. 14.00x24 ladder Description: Tire chain	Part No. USA 2615 S 10mm Description: 10mm Square	150	1 EA	\$ 1,355.14	1.00	-65.00%	\$ 474.30	\$474.30
14	Part No. 225/75r19.5 zigzag Description: Tire chain	Part No. USA ZZ 2228 SC Description: Zig Zag Square	150	1 EA	\$ 374.78	1.00	-65.00%	\$ 131.17	\$131.17
15	Part No. 245/75r19.5 zigzag Description: Tire chain	Part No. USA ZZ 2228 SC Description: Zig Zag Square	150	1 EA	\$ 374.78	1.00	-65.00%	\$ 131.17	\$131.17
Total Bid Amount									\$5,284.98

CONTRACT MANAGER: Tammy Knight

TELEPHONE NUMBER: 304-641-3132

FAX NUMBER: 866-472-8775

E-MAIL ADDRESS: tammyk@pewagchain.com



Effective July 1, 2019

Pewag Traction Chain Price list

Description	ITEM	UOM	LIST Price
Adjuster	103	PAIR	\$56.60
Cam Tool	204	EACH	\$9.24
Multi Tool	205	EACH	\$67.31
Cross Chain Hook	403	EACH	\$0.77
Cross Chain Hook	405	EACH	\$1.32
Cross Chain Hook	406	EACH	\$1.52
Cross Chain Hook	409	EACH	\$2.31
Cross Chain Hook	411	EACH	\$3.73
Repair Link	705	EACH	\$1.57
Repair Link	707	EACH	\$2.22
Repair Link	708	EACH	\$2.75
Repair Link	710	EACH	\$5.36
Repair Link	712	EACH	\$7.46
Side Chain	1008	FT.	\$8.30
Side Chain	1010	FT.	\$9.60
Side Chain	1012	FT.	\$21.62
pewag Cross Chain - Continuous	3003	FT.	\$4.78
pewag Cross Chain - Continuous	3004	FT.	\$5.53
pewag Cross Chain - Continuous	3005	FT.	\$7.70
pewag Cross Chain - Continuous	3007	FT.	\$9.58
pewag Cross Chain - Continuous	3008	FT.	\$11.45
pewag Cross Chain - Continuous	3010	FT.	\$19.90
pewag Cross Chain - Continuous	3012	FT.	\$29.37
Universal	3481	PAIR	\$10,848.24
Cross chain W/O Hooks	4409	EACH	\$84.58
Cross chain W/O Hooks	4451	EACH	\$39.82
Cross chain W/O Hooks	4452	EACH	\$44.69
Repair Ring	5073	EACH	\$2.87
Universal fastener	5297	EACH	\$62.73
Cross chain W/O Hooks	5837	EACH	\$24.69
Fastener	8220	EACH	\$8.52
Fastener	8230	EACH	\$13.48
Universal Links	9900	EACH	\$17.24
Universal Links	9902	EACH	\$25.09
Universal Links	9904	EACH	\$36.73
Universal Feld	10527	PAIR	\$546.23
End Hook	12013	EACH	\$8.63
Universal Feld	22532	PAIR	\$514.65
Universal Feld	22533	PAIR	\$493.19
Universal Feld	27397	PAIR	\$909.91

Universal Feld	27404	PAIR	\$1,255.69
Universal Feld	27405	PAIR	\$881.34
Erzberg Feld	29567	PAIR	\$2,041.01
Universal Feld	29575	PAIR	\$1,301.75
Universal Feld	29576	PAIR	\$1,395.20
Universal	30669	PAIR	\$21,159.59
Universal Feld	31845	PAIR	\$967.43
Cross chain W/O Hooks	33187	EACH	\$94.70
Pin Lock	35326	EACH	\$65.77
Cross chain W/O Hooks	36250	EACH	\$21.74
Cross chain W/O Hooks	37795	EACH	\$54.72
Cross chain W/O Hooks	37801	EACH	\$65.82
Universal	45657	PAIR	\$4,955.41
Cross chain W/O Hooks	51890	EACH	\$20.08
Cross chain W/O Hooks	58325	EACH	\$65.43
Cross chain W/O Hooks	58447	EACH	\$16.92
Cross chain W/O Hooks	58448	EACH	\$19.61
Erzberg Feld	58617	PAIR	\$852.62
Erzberg Feld	58618	PAIR	\$929.26
Erzberg Feld	58622	PAIR	\$890.68
Universal Feld	58623	PAIR	\$1,974.98
Universal Feld	58624	PAIR	\$480.96
Universal Feld	58700	PAIR	\$1,307.93
Universal	60197	PAIR	\$5,015.62
Universal Feld	62049	PAIR	\$958.39
Universal Feld	63783	PAIR	\$1,230.68
Universal	69112	PAIR	\$11,251.27
Universal	69119	PAIR	\$8,244.16
Universal	69120	PAIR	\$5,550.76
Universal	69121	PAIR	\$5,688.98
Universal	69122	PAIR	\$5,870.19
Universal	69123	PAIR	\$9,432.00
Universal	69124	PAIR	\$9,914.67
Universal	69125	PAIR	\$10,305.73
Erzberg	69128	PAIR	\$26,579.80
Erzberg	69129	PAIR	\$59,414.95
Erzberg	69141	PAIR	\$19,002.84
Erzberg	69142	PAIR	\$30,479.31
Erzberg	69143	PAIR	\$30,436.44
Erzberg	69144	PAIR	\$33,420.40
Erzberg	69145	PAIR	\$36,575.25
Erzberg	69149	PAIR	\$11,395.07
Universal	69150	PAIR	\$12,603.60
Universal	69155	PAIR	\$3,785.72
Universal	69156	PAIR	\$8,687.71
Universal	69157	PAIR	\$7,620.57
Universal	69158	PAIR	\$8,424.27
Universal	69159	PAIR	\$11,768.95
Universal	69160	PAIR	\$9,409.49
Universal	69161	PAIR	\$13,639.46
Universal	69162	PAIR	\$4,678.96
Universal	69163	PAIR	\$5,015.62
Universal	69164	PAIR	\$4,747.90
Universal	69175	PAIR	\$506.57

Item 4

Universal	71793	EACH	\$9.45
Universal	84849	PAIR	\$13,045.15
Erzberg	85713	PAIR	\$12,686.02
Universal Feld	85982	PAIR	\$1,790.07
Erzberg Feld	86189	PAIR	\$1,318.41
Erzberg Feld	86190	PAIR	\$1,898.62
Erzberg Feld	86194	PAIR	\$1,284.63
Erzberg	93087	PAIR	\$19,735.96
Erzberg	95122	PAIR	\$18,676.42
Erzberg repair links	01386	EACH	\$65.43
Erzberg repair links	01390	EACH	\$75.91
pewag Side Chain - Continuous	05625	EACH	\$60.19
pewag Side Chain - Continuous	1004A	FT.	\$5.11
pewag Side Chain - Continuous	1006USA	FT.	\$5.91
pewag Side Chain - Continuous	1007USA	FT.	\$6.65
pewag Side Chain - Continuous	1009A	FT.	\$7.68
pewag Side Chain - Continuous	1011A	FT.	\$17.30
pewag Side Chain - Continuous	1016USA	EACH	\$90.49
pewag Side Chain - Continuous	1017USA	EACH	\$77.17
pewag Side Chain - Continuous	1019USA	EACH	\$104.29
Universal Feld	29370F	PAIR	\$987.18
pewag cross chain - Continuous	3008TSL	FT.	\$13.37
pewag cross chain - Continuous	3010TSL	FT.	\$20.96
Universal Feld	3188F	PAIR	\$927.25
Fastener	319USA	EACH	\$7.51
Fastener	320USA	EACH	\$9.42
Fastener	407USA	EACH	\$1.84
Fastener	5835USA	EACH	\$9.96
Fastener	5927USA	EACH	\$8.56
pewag universal / Erzberg Repair SI	7066TC	EACH	\$12.28
pewag universal / Erzberg Repair SI	7067TC	EACH	\$18.84
pewag universal / Erzberg Repair SI	7068TC	EACH	\$24.96
pewag universal / Erzberg Repair SI	7084TC	EACH	\$46.62
pewag universal / Erzberg Repair SI	7093TC	EACH	\$11.54
pewag universal / Erzberg Repair SI	7094TC	EACH	\$17.18
Lever	8250-KST	EACH	\$24.84
Lever	8250-N	EACH	\$28.49
pewag ASV	A 01 SV	PAIR	\$2,402.41
pewag ASV	A 02 SV	PAIR	\$2,434.46
pewag ASV	A 08 SV	PAIR	\$2,946.84
pewag ASV	A 10 SV	PAIR	\$3,292.51
pewag ASV	A 155 8 SV	PAIR	\$3,837.50
pewag ASV	A 160 8 SV	PAIR	\$3,973.75
pewag ASV	A 291 SV	PAIR	\$3,231.69
pewag ASV	A 294 SV	PAIR	\$3,590.77
pewag ASV	A 297 SV	PAIR	\$4,400.37
pewag ASV	A 74 SV	PAIR	\$1,150.35
pewag ASV	A 75 SV	PAIR	\$1,174.57
pewag ASV	A 76 SV	PAIR	\$1,174.57
pewag ASV	A 77 SV	PAIR	\$1,174.57
pewag ASV	A 78 SV	PAIR	\$1,174.57
pewag ASV	A 79 SV	PAIR	\$1,319.88
pewag ASV	A 80 SV	PAIR	\$1,356.75
pewag ASV	A 81 SV	PAIR	\$1,365.40

pewag ASV	A 81A SV	PAIR	\$1,365.40
pewag ASV	A 82 SV	PAIR	\$1,451.81
pewag ASV	A 83 SV	PAIR	\$1,460.46
pewag ASV	A 84 SV	PAIR	\$1,469.10
pewag ASV	A 85 SV	PAIR	\$1,581.44
pewag ASV	A 86 SV	PAIR	\$1,692.14
pewag ASV	A 87 SV	PAIR	\$1,750.35
pewag ASV	A 88 SV	PAIR	\$1,667.86
pewag ASV	A 89 SV	PAIR	\$1,834.65
pewag ASV	A 90 SV	PAIR	\$1,853.18
pewag ASV	A 91 SV	PAIR	\$1,955.79
pewag ASV	A 93 8 SV	PAIR	\$1,985.13
pewag ASV	A 93 SV	PAIR	\$1,975.20
pewag ASV	A 94 5 SV	PAIR	\$1,114.79
pewag ASV	A 94 SV	PAIR	\$2,229.57
pewag ASV	A 95 SV	PAIR	\$2,315.99
pewag ASV	A 97 SV	PAIR	\$2,315.99
pewag cervino	CL 01 R	PAIR	\$844.40
pewag cervino	CL 02 R	PAIR	\$858.93
pewag cervino	CL 05 R	PAIR	\$949.34
pewag cervino	CL 08 R	PAIR	\$1,007.47
pewag cervino	CL 160 7 R	PAIR	\$1,101.11
pewag cervino	CL 201 R	PAIR	\$1,601.61
pewag cervino	CL 294 R	PAIR	\$1,393.34
pewag cervino	CL 297 R	PAIR	\$1,456.30
pewag cervino	CL 87 R	PAIR	\$600.60
pewag cervino	CL 89 R	PAIR	\$737.84
pewag cervino	CL 91 R	PAIR	\$768.52
pewag cervino	CL 93 7 R	PAIR	\$776.59
pewag cervino	CL 93 R	PAIR	\$768.52
pewag cervino	CL 94 R	PAIR	\$776.59
pewag cervino	CL 95 R	PAIR	\$808.88
pewag cervino	CL 97 R	PAIR	\$808.88
pewag servo	RS 60	PAIR	\$212.02
pewag servo	RS 62	PAIR	\$212.02
pewag servo	RS 64	PAIR	\$212.02
pewag servo	RS 67	PAIR	\$212.02
pewag servo	RS 68	PAIR	\$212.02
pewag servo	RS 69	PAIR	\$212.02
pewag servo	RS 73	PAIR	\$212.02
pewag servo	RS 74	PAIR	\$212.02
pewag servo	RS 75	PAIR	\$241.88
pewag servo	RS 76	PAIR	\$241.88
pewag servo	RS 77	PAIR	\$241.88
pewag servo	RS 79	PAIR	\$241.88
pewag servo	RS 80	PAIR	\$250.84
pewag servo suv	RSV 62	PAIR	\$269.61
pewag servo suv	RSV 64	PAIR	\$269.61
pewag servo suv	RSV 67	PAIR	\$269.61
pewag servo suv	RSV 68	PAIR	\$269.61
pewag servo suv	RSV 69	PAIR	\$269.61
pewag servo suv	RSV 73	PAIR	\$269.61
pewag servo suv	RSV 74	PAIR	\$269.61
pewag servo suv	RSV 75	PAIR	\$310.56

pewag servo suv	RSV 76	PAIR	\$310.56
pewag servo suv	RSV 77	PAIR	\$310.56
pewag servo suv	RSV 79	PAIR	\$310.56
pewag servo suv	RSV 80	PAIR	\$344.69
pewag servo suv	RSV 80A	PAIR	\$344.69
pewag servo suv	RSV 81	PAIR	\$344.69
pewag servo suv	RSV 81A	PAIR	\$344.69
pewag servo suv	RSV 82	PAIR	\$344.69
pewag snox pro	SXP 500	PAIR	\$230.75
pewag snox pro	SXP 505	PAIR	\$230.75
pewag snox pro	SXP 510	PAIR	\$230.75
pewag snox pro	SXP 520	PAIR	\$264.68
pewag snox pro	SXP 530	PAIR	\$264.68
pewag snox pro	SXP 540	PAIR	\$264.68
pewag snox pro	SXP 550	PAIR	\$303.70
pewag snox pro	SXP 560	PAIR	\$303.70
pewag snox pro	SXP 570	PAIR	\$303.70
pewag snox pro	SXV 570	PAIR	\$348.76
pewag snox pro	SXV 580	PAIR	\$348.76
pewag snox pro	SXV 590	PAIR	\$382.30
pewag snox pro	SXV 600	PAIR	\$382.30
pewag tite-n-lite	TNL 2245 SC	PAIR	\$838.88
pewag tite-n-lite	TNL 2249 SC	PAIR	\$910.11
pewag tite-n-lite	TNL 4245 SC	PAIR	\$1,593.91
pewag tite-n-lite	TNL 4249 SC	PAIR	\$1,729.27
pewag CL-PSC	USA 01 PSC	PAIR	\$611.09
pewag CL-PSC	USA 02 PSC	PAIR	\$620.39
pewag Tractor Chains	USA0822 S 8.2mm	PAIR	\$689.41
pewag Tractor Chains	USA 0829 S 8.2mm	PAIR	\$580.58
pewag Tractor Chains	USA 0831 S 8.2mm	PAIR	\$708.76
pewag Tractor Chains	USA 0832 S 8.2mm	PAIR	\$749.44
pewag Tractor Chains	USA 0834 S 8.2mm	PAIR	\$750.44
pewag Tractor Chains	USA 0836 S 8.2mm	PAIR	\$833.01
pewag Tractor Chains	USA 0838 S 8.2mm	PAIR	\$959.79
pewag Tractor Chains	USA 0846 S 8.2mm	PAIR	\$1,154.27
pewag Tractor Chains	USA 0850 S 10mm	PAIR	\$1,016.12
pewag Tractor Chains	USA 0850 S 8.2mm	PAIR	\$761.91
pewag Tractor Chains	USA 0852 S 10mm	PAIR	\$1,225.41
pewag Tractor Chains	USA 0852 S 8.2mm	PAIR	\$900.00
pewag Tractor Chains	USA 0856 S 10mm	PAIR	\$1,399.02
pewag Tractor Chains	USA 0856 S 8.2mm	PAIR	\$1,023.41
pewag Tractor Chains	USA 0858 S 10mm	PAIR	\$1,427.44
pewag Tractor Chains	USA 0858 S 8.2mm	PAIR	\$1,035.17
pewag Tractor Chains	USA 0859 S 10mm	PAIR	\$1,846.68
pewag Tractor Chains	USA 0859 S 8.2mm	PAIR	\$1,314.36
pewag Tractor Chains	USA 0862 S 10mm	PAIR	\$1,641.58
pewag Tractor Chains	USA 0862 S 8.2mm	PAIR	\$1,221.51
pewag Tractor Chains	USA 0866 S 10mm	PAIR	\$2,493.43
pewag Tractor Chains	USA 0866 S 8.2mm	PAIR	\$1,902.04
pewag Tractor Chains	USA 0869 S 10mm	PAIR	\$2,119.21
pewag Tractor Chains	USA 0869 S 8.2mm	PAIR	\$1,616.59
pewag Tractor Chains	USA 0871 S 10mm	PAIR	\$2,624.94
pewag Tractor Chains	USA 0871 S 8.2mm	PAIR	\$2,002.35
pewag Tractor Chains	USA 0874 S 10mm	PAIR	\$2,224.19

pewag Tractor Chains	USA 0874 S 8.2mm	PAIR	\$1,696.68	
pewag Tractor Chains	USA 0876 S 10mm	PAIR	\$2,370.64	
pewag Tractor Chains	USA 0876 S 8.2mm	PAIR	\$1,808.40	
pewag Tractor Chains	USA 0877 S 10mm	PAIR	\$2,507.95	
pewag Tractor Chains	USA 0877 S 8.2mm	PAIR	\$1,913.10	
pewag Tractor Chains	USA 0879 S 10mm	PAIR	\$2,654.51	
pewag Tractor Chains	USA 0879 S 8.2mm	PAIR	\$2,024.90	
pewag Tractor Chains	USA 0881 S 10mm	PAIR	\$1,430.53	
pewag Tractor Chains	USA 0881 S 12mm	PAIR	\$1,999.22	
pewag Tractor Chains	USA 0882 S 10mm	PAIR	\$1,682.96	
pewag Tractor Chains	USA 0882 S 12mm	PAIR	\$2,206.23	
pewag Tractor Chains	USA 0883 S 10mm	PAIR	\$1,956.00	
pewag Tractor Chains	USA 0883 S 12mm	PAIR	\$2,421.33	
pewag Tractor Chains	USA 0884 S 10mm	PAIR	\$1,920.09	
pewag Tractor Chains	USA 0884 S 12mm	PAIR	\$2,516.34	
pewag Tractor Chains	USA 0885 S 10mm	PAIR	\$2,280.89	
pewag Tractor Chains	USA 0885 S 12mm	PAIR	\$2,888.65	
pewag Tractor Chains	USA 0887 S 10mm	PAIR	\$2,176.45	
pewag Tractor Chains	USA 0887 S 12mm	PAIR	\$2,857.84	
pewag Tractor Chains	USA 0889 S 10mm	PAIR	\$2,601.53	
pewag Tractor Chains	USA 0889 S 12mm	PAIR	\$3,289.05	
pewag Tractor Chains	USA 0890 S 10mm	PAIR	\$3,131.75	
pewag Tractor Chains	USA 0890 S 12mm	PAIR	\$3,961.17	
pewag Tractor Chains	USA 0891 S 10mm	PAIR	\$2,416.74	
pewag Tractor Chains	USA 0891 S 12mm	PAIR	\$3,060.25	
pewag Tractor Chains	USA 0892 S 10mm	PAIR	\$2,752.80	
pewag Tractor Chains	USA 0892 S 12mm	PAIR	\$3,482.11	
pewag Tractor Chains	USA 0893 S 10mm	PAIR	\$2,745.65	
pewag Tractor Chains	USA 0893 S 12mm	PAIR	\$3,474.96	
pewag Tractor Chains	USA 0894 S 10mm	PAIR	\$2,886.22	
pewag Tractor Chains	USA 0894 S 12mm	PAIR	\$3,783.61	
pewag Tractor Chains	USA 0895 S 10mm	PAIR	\$3,739.51	
pewag Tractor Chains	USA 0895 S 12mm	PAIR	\$4,733.38	
pewag CL-PSC	USA 155 PSC	PAIR	\$757.64	
pewag CL-PSC	USA 160 7 PSC	PAIR	\$772.15	
pewag CL-PSC	USA 162 PSC	PAIR	\$727.70	
pewag LT Ladder - Singles	USA2209 S	PAIR	\$321.62	
pewag LT Ladder - Singles	USA 2209 SC	PAIR	\$321.62	
pewag LT Ladder - Singles	USA 2211 S	PAIR	\$363.11	
pewag LT Ladder - Singles	USA 2211 SC	PAIR	\$363.11	
pewag LT Ladder - Singles	USA 2214 S	PAIR	\$401.85	
pewag LT Ladder - Singles	USA 2214 SC	PAIR	\$401.85	
pewag LT Ladder - Singles	USA 2216 S	PAIR	\$347.61	
pewag LT Ladder - Singles	USA 2216 SC	PAIR	\$347.61	
pewag LT Ladder - Singles	USA 2219 S	PAIR	\$362.53	
pewag LT Ladder - Singles	USA 2219 SC	PAIR	\$362.53	Item 10
pewag LT Ladder - Singles	USA 2219 SC 7ST	PAIR	\$490.54	
pewag LT Ladder - Singles	USA 2221 S	PAIR	\$377.48	
pewag LT Ladder - Singles	USA 2221 SC	PAIR	\$377.48	Items 8, 11
pewag LT Ladder - Singles	USA 2221 SC 7ST	PAIR	\$516.35	
pewag LT Ladder - Singles	USA 2226 S	PAIR	\$431.94	
pewag LT Ladder - Singles	USA 2226 SC	PAIR	\$431.94	
pewag LT Ladder - Singles	USA 2228 S	PAIR	\$400.24	
pewag LT Ladder - Singles	USA 2228 SC	PAIR	\$400.24	Item 9

pewag LT Ladder - Singles	USA 2228 SC 7ST	PAIR	\$543.55
pewag LT Ladder - Singles	USA 2229 S	PAIR	\$357.05
pewag LT Ladder - Singles	USA 2229 SC	PAIR	\$357.05
pewag HT Ladder - Singles	USA2233 S	PAIR	\$334.68
pewag HT Ladder - Singles	USA 2233 SC	PAIR	\$334.68
pewag HT Ladder - Singles	USA 2237 S	PAIR	\$364.94
pewag HT Ladder - Singles	USA 2237 SC	PAIR	\$364.94
pewag HT Ladder - Singles	USA 2238 S	PAIR	\$388.77
pewag HT Ladder - Singles	USA 2238 SC	PAIR	\$388.77
pewag HT Ladder - Singles	USA 2239 S	PAIR	\$390.19
pewag HT Ladder - Singles	USA 2239 SC	PAIR	\$390.19
pewag HT Ladder - Singles	USA 2241 S	PAIR	\$400.65
pewag HT Ladder - Singles	USA 2241 SC	PAIR	\$400.65
pewag HT Ladder - Singles	USA 2245 S	PAIR	\$410.31
pewag HT Ladder - Singles	USA 2245 SC	PAIR	\$410.31
pewag HT Ladder - Singles	USA 2247 S	PAIR	\$393.28
pewag HT Ladder - Singles	USA 2247 S 7ST	PAIR	\$545.03
pewag HT Ladder - Singles	USA 2247 S 8ST	PAIR	\$712.37
pewag HT Ladder - Singles	USA 2247 SC	PAIR	\$393.28
pewag HT Ladder - Singles	USA 2247 SC 7ST	PAIR	\$583.20
pewag HT Ladder - Singles	USA 2247 SC 8ST	PAIR	\$772.59
pewag HT Ladder - Singles	USA 2249 S	PAIR	\$420.16
pewag HT Ladder - Singles	USA 2249 S 7ST	PAIR	\$621.53
pewag HT Ladder - Singles	USA 2249 S 8ST	PAIR	\$741.05
pewag HT Ladder - Singles	USA 2249 SC	PAIR	\$420.16
pewag HT Ladder - Singles	USA 2249 SC 7ST	PAIR	\$664.09
pewag HT Ladder - Singles	USA 2249 SC 8ST	PAIR	\$802.81
pewag HT Ladder - Singles	USA 2251 S	PAIR	\$420.16
pewag HT Ladder - Singles	USA 2251 SC	PAIR	\$420.16
pewag HT Ladder - Singles	USA 2253 S	PAIR	\$585.65
pewag HT Ladder - Singles	USA 2253 SC	PAIR	\$585.65
pewag HT Ladder - Singles	USA 2255 S	PAIR	\$559.11
pewag HT Ladder - Singles	USA 2255 S 7ST	PAIR	\$731.21
pewag HT Ladder - Singles	USA 2255 SC	PAIR	\$559.11
pewag HT Ladder - Singles	USA 2255 SC 7ST	PAIR	\$781.28
pewag HT Ladder - Singles	USA 2257 S	PAIR	\$605.70
pewag HT Ladder - Singles	USA 2257 SC	PAIR	\$605.70
pewag HT Ladder - Singles	USA 2271 S	PAIR	\$781.28
pewag HT Ladder - Singles	USA 2271 SC	PAIR	\$781.28
pewag HT Ladder - Singles	USA 2273 S	PAIR	\$816.59
pewag HT Ladder - Singles	USA 2273 SC	PAIR	\$816.59
pewag Mud Service - Singles	USA2433 S	PAIR	\$486.02
pewag Mud Service - Singles	USA 2435 S	PAIR	\$506.88
pewag Mud Service - Singles	USA 2437 S	PAIR	\$527.78
pewag Mud Service - Singles	USA 2439 S	PAIR	\$559.58
pewag Mud Service - Singles	USA 2441 S	PAIR	\$682.62
pewag Mud Service - Singles	USA 2445 S	PAIR	\$712.00
pewag Mud Service - Singles	USA 2448 S	PAIR	\$747.78
pewag Mud Service - Singles	USA 2448 SC	PAIR	\$747.78
pewag Mud Service - Singles	USA 2452 S	PAIR	\$779.95
pewag Mud Service - Singles	USA 2452 SC	PAIR	\$779.95
pewag Mud Service - Singles	USA 2486 S	PAIR	\$957.34
pewag Heavy Equip. Chains	USA2612 S 8.2MM	PAIR	\$1,022.15
pewag heavy Equip. Chains	USA 2612 S 10mm	PAIR	\$1,187.77

Item 6

Item 5

pewag Heavy Equip. Chains	USA 2612 S 10mm DS	PAIR	\$2,863.40	
pewag Heavy Equip. Chains	USA 2612 S 12mm	PAIR	\$2,100.84	
pewag Heavy Equip. Chains	USA 2612 S 12mm DS	PAIR	\$3,991.59	
pewag Heavy Equip. Chains	USA 2612 S 8.2mm	PAIR	\$1,022.15	
pewag Heavy Equip. Chains	USA 2612 S 8.2mm DS	PAIR	\$1,942.09	
pewag Heavy Equip. Chains	USA 2615 S 10mm	PAIR	\$1,355.14	Items 12, 13
pewag Heavy Equip. Chains	USA 2615 S 10mm DS	PAIR	\$2,400.00	Item 2
pewag Heavy Equip. Chains	USA 2615 S 12mm	PAIR	\$2,349.73	
pewag Heavy Equip. Chains	USA 2615 S 12mm DS	PAIR	\$4,464.48	
pewag Heavy Equip. Chains	USA 2615 S 8.2mm	PAIR	\$1,149.05	
pewag Heavy Equip. Chains	USA 2615 S 8.2mm DS	PAIR	\$2,183.19	
pewag Heavy Equip. Chains	USA 2624 S 10mm	PAIR	\$1,610.00	Item 7
pewag Heavy Equip. Chains	USA 2624 S 10mm DS	PAIR	\$3,295.37	
pewag Heavy Equip. Chains	USA 2624 S 12mm	PAIR	\$2,407.09	
pewag Heavy Equip. Chains	USA 2624 S 12mm DS	PAIR	\$4,573.47	
pewag Heavy Equip. Chains	USA 2627 S 10mm	PAIR	\$1,981.50	
pewag Heavy Equip. Chains	USA 2627 S 10mm DS	PAIR	\$3,764.85	
pewag Heavy Equip. Chains	USA 2627 S 12mm	PAIR	\$3,123.51	
pewag Heavy Equip. Chains	USA 2627 S 12mm DS	PAIR	\$5,934.67	
pewag Heavy Equip. Chains	USA 2633 S 10mm	PAIR	\$2,108.67	
pewag Heavy Equip. Chains	USA 2633 S 10mm DS	PAIR	\$4,006.48	
pewag Heavy Equip. Chains	USA 2633 S 12mm	PAIR	\$3,203.19	
pewag Heavy Equip. Chains	USA 2633 S 12mm DS	PAIR	\$6,086.06	
pewag Heavy Equip. Chains	USA 2636 S 10mm	PAIR	\$2,230.02	
pewag Heavy Equip. Chains	USA 2636 S 10mm DS	PAIR	\$4,237.04	
pewag Heavy Equip. Chains	USA 2636 S 12mm	PAIR	\$3,371.78	
pewag Heavy Equip. Chains	USA 2636 S 12mm DS	PAIR	\$6,406.38	
pewag Heavy Equip. Chains	USA 2642 S 10mm	PAIR	\$2,800.40	
pewag Heavy Equip. Chains	USA 2642 S 10mm DS	PAIR	\$5,320.75	
pewag Heavy Equip. Chains	USA 2642 S 12mm	PAIR	\$3,837.33	
pewag Heavy Equip. Chains	USA 2642 S 12mm DS	PAIR	\$7,290.92	
pewag Heavy Equip. Chains	USA 2645 S 10mm	PAIR	\$3,003.17	
pewag Heavy Equip. Chains	USA 2645 S 10mm DS	PAIR	\$5,706.03	
pewag Heavy Equip. Chains	USA 2645 S 12mm	PAIR	\$3,969.70	
pewag Heavy Equip. Chains	USA 2645 S 12mm DS	PAIR	\$7,542.43	
pewag Heavy Equip. Chains	USA 2648 S 10mm	PAIR	\$3,052.94	
pewag Heavy Equip. Chains	USA 2648 S 10mm DS	PAIR	\$5,800.58	
pewag Heavy Equip. Chains	USA 2648 S 12mm	PAIR	\$3,764.49	
pewag Heavy Equip. Chains	USA 2648 S 12mm DS	PAIR	\$7,152.53	
pewag Heavy Equip. Chains	USA 2654 S 10mm	PAIR	\$3,594.15	
pewag Heavy Equip. Chains	USA 2654 S 10mm DS	PAIR	\$6,828.89	
pewag Heavy Equip. Chains	USA 2654 S 12mm	PAIR	\$4,014.04	
pewag Heavy Equip. Chains	USA 2654 S 12mm DS	PAIR	\$7,626.68	
pewag Heavy Equip. Chains	USA 2657 S 10mm	PAIR	\$3,153.13	
pewag Heavy Equip. Chains	USA 2657 S 10mm DS	PAIR	\$5,990.95	
pewag Heavy Equip. Chains	USA 2657 S 12mm	PAIR	\$4,979.55	
pewag Heavy Equip. Chains	USA 2657 S 12mm DS	PAIR	\$9,461.15	
pewag Heavy Equip. Chains	USA 2660 S 10mm	PAIR	\$3,616.10	
pewag Heavy Equip. Chains	USA 2660 S 10mm DS	PAIR	\$6,870.58	
pewag Heavy Equip. Chains	USA 2660 S 12mm	PAIR	\$4,699.77	
pewag Heavy Equip. Chains	USA 2660 S 12mm DS	PAIR	\$8,929.57	
pewag Heavy Equip. Chains	USA 2672 S 10mm	PAIR	\$3,679.85	
pewag Heavy Equip. Chains	USA 2672 S 10mm DS	PAIR	\$6,991.71	
pewag Heavy Equip. Chains	USA 2672 S 12mm	PAIR	\$5,520.53	

pewag Heavy Equip. Chains	USA 2672 S 12mm DS	PAIR	\$10,489.01	
pewag Heavy Equip. Chains	USA 2675 S 10mm	PAIR	\$3,895.46	
pewag Heavy Equip. Chains	USA 2675 S 10mm DS	PAIR	\$7,401.38	
pewag Heavy Equip. Chains	USA 2675 S 12mm	PAIR	\$5,842.47	
pewag Heavy Equip. Chains	USA 2675 S 12mm DS	PAIR	\$11,100.70	
pewag Wide Base	USA 3210 S	PAIR	\$372.81	
pewag Wide Base	USA 3210 SC	PAIR	\$372.81	Items 1, 3
pewag Wide Base	USA 3226 S	Pair	\$362.53	
pewag Wide Base	USA 3226 SC	Pair	\$362.53	
pewag Wide Base	USA 3227 S	PAIR	\$371.20	
pewag Wide Base	USA 3227 SC	PAIR	\$371.20	
pewag Wide Base	USA 3227 SC 7ST	PAIR	\$483.75	
pewag Wide Base	USA 3229 S	PAIR	\$396.64	
pewag Wide Base	USA 3229 SC	PAIR	\$396.64	
pewag Wide Base	USA 3229 SC 7ST	PAIR	\$483.78	
pewag Wide Base	USA 3231 S	PAIR	\$434.17	
pewag Wide Base	USA 3231 SC	PAIR	\$434.17	
pewag Wide Base	USA 3231 SC 7ST	PAIR	\$549.43	
pewag Wide Base	USA 3235 S	PAIR	\$471.22	
pewag Wide Base	USA 3235 SC	PAIR	\$471.22	
pewag Wide Base	USA 3235 SC 7ST	PAIR	\$583.51	
pewag Wide Base	USA 3237 S	PAIR	\$509.60	
pewag Wide Base	USA 3237 SC	PAIR	\$509.60	
pewag Wide Base	USA 3249 S	PAIR	\$522.30	
pewag Wide Base	USA 3249 SC	PAIR	\$522.30	
pewag Wide Base	USA 3251 S	PAIR	\$551.06	
pewag Wide Base	USA 3251 SC	PAIR	\$551.06	
pewag Wide Base	USA 3255 S	PAIR	\$602.54	
pewag Wide Base	USA 3255 S 8ST	PAIR	\$892.52	
pewag Wide Base	USA 3255 S 8ST DS	PAIR	\$1,286.15	
pewag Wide Base	USA 3255 SC	PAIR	\$602.54	
pewag Wide Base	USA 3255 SC 8ST	PAIR	\$939.49	
pewag Wide Base	USA 3257 S	PAIR	\$643.69	
pewag Wide Base	USA 3257 SC	PAIR	\$643.69	
pewag Wide Base	USA 3259 S	PAIR	\$502.14	
pewag Wide Base	USA 3259 SC	PAIR	\$502.14	
pewag Wide Base	USA 3261 S	PAIR	\$724.13	
pewag Wide Base	USA 3261 S 8ST	PAIR	\$874.18	
pewag Wide Base	USA 3261 S 8ST DS	PAIR	\$1,296.20	
pewag Wide Base	USA 3261 SC	PAIR	\$724.13	
pewag Wide Base	USA 3265 S	PAIR	\$548.65	
pewag Wide Base	USA 3265 SC	PAIR	\$548.65	
pewag Wide Base	USA 3267 S	PAIR	\$562.67	
pewag Wide Base	USA 3267 SC	PAIR	\$562.67	
pewag Wide Base	USA 3269 S	PAIR	\$609.45	
pewag Wide Base	USA 3269 SC	PAIR	\$609.45	
pewag Wide Base	USA 3271 S	PAIR	\$710.93	
pewag Wide Base	USA 3271 S 8ST	PAIR	\$880.67	
pewag Wide Base	USA 3271 S 8ST DS	PAIR	\$1,451.94	
pewag Wide Base	USA 3271 SC	PAIR	\$710.93	
pewag Wide Base	USA 3271 SC 8ST	PAIR	\$978.53	
pewag Wide Base	USA 3273 S	PAIR	\$655.09	
pewag Wide Base	USA 3273 SC	PAIR	\$655.09	
pewag Wide Base	USA 3275 S	PAIR	\$731.12	

pewag Wide Base	USA 3275 SC	PAIR	\$731.12
pewag Wide Base	USA 3277 S	PAIR	\$894.51
pewag Wide Base	USA 3277 SC	PAIR	\$894.51
pewag LT Ladder - Duals	USA 4211 S	PAIR	\$718.95
pewag LT Ladder - Duals	USA 4211 SC	PAIR	\$718.95
pewag LT Ladder - Duals	USA 4214 S	PAIR	\$795.66
pewag LT Ladder - Duals	USA 4214 SC	PAIR	\$795.66
pewag LT Ladder - Duals	USA 4216 S	PAIR	\$688.26
pewag LT Ladder - Duals	USA 4216 SC	PAIR	\$688.26
pewag LT Ladder - Duals	USA 4219 S	PAIR	\$717.82
pewag LT Ladder - Duals	USA 4219 SC	PAIR	\$717.82
pewag LT Ladder - Duals	USA 4221 S	PAIR	\$747.41
pewag LT Ladder - Duals	USA 4221 SC	PAIR	\$747.41
pewag LT Ladder - Duals	USA 4221 SC 7ST	PAIR	\$914.55
pewag LT Ladder - Duals	USA 4226 S	PAIR	\$831.59
pewag LT Ladder - Duals	USA 4226 SC	PAIR	\$855.24
pewag LT Ladder - Duals	USA 4228 S	PAIR	\$792.47
pewag LT Ladder - Duals	USA 4228 SC	PAIR	\$792.47
pewag LT Ladder - Duals	USA 4228 SC 7ST	PAIR	\$962.68
pewag LT Ladder - Duals	USA 4229 S	PAIR	\$706.95
pewag LT Ladder - Duals	USA 4229 SC	PAIR	\$706.95
pewag HT Ladder - Duals	USA4233 S	PAIR	\$722.58
pewag HT Ladder - Duals	USA 4233 SC	PAIR	\$722.58
pewag HT Ladder - Duals	USA 4237 S	PAIR	\$736.29
pewag HT Ladder - Duals	USA 4237 SC	PAIR	\$736.29
pewag HT Ladder - Duals	USA 4238 S	PAIR	\$742.27
pewag HT Ladder - Duals	USA 4238 SC	PAIR	\$742.27
pewag HT Ladder - Duals	USA 4239 S	PAIR	\$748.23
pewag HT Ladder - Duals	USA 4239 SC	PAIR	\$748.23
pewag HT Ladder - Duals	USA 4241 S	PAIR	\$793.29
pewag HT Ladder - Duals	USA 4241 SC	PAIR	\$793.29
pewag HT Ladder - Duals	USA 4245 S	PAIR	\$812.41
pewag HT Ladder - Duals	USA 4245 SC	PAIR	\$812.41
pewag HT Ladder - Duals	USA 4247 S	PAIR	\$819.67
pewag HT Ladder - Duals	USA 4247 S 7ST	PAIR	\$1,037.47
pewag HT Ladder - Duals	USA 4247 S 8ST	PAIR	\$1,152.75
pewag HT Ladder - Duals	USA 4247 SC	PAIR	\$819.67
pewag HT Ladder - Duals	USA 4247 SC 7ST	PAIR	\$1,106.83
pewag HT Ladder - Duals	USA 4247 SC 8ST	PAIR	\$1,229.81
pewag HT Ladder - Duals	USA 4249 S	PAIR	\$881.59
pewag HT Ladder - Duals	USA 4249 S 7ST	PAIR	\$1,104.41
pewag HT Ladder - Duals	USA 4249 S 8ST	PAIR	\$1,227.12
pewag HT Ladder - Duals	USA 4249 SC	PAIR	\$881.59
pewag HT Ladder - Duals	USA 4249 SC 7ST	PAIR	\$1,179.20
pewag HT Ladder - Duals	USA 4249 SC 8ST	PAIR	\$1,310.22
pewag HT Ladder - Duals	USA 4251 S	PAIR	\$888.83
pewag HT Ladder - Duals	USA 4251 SC	PAIR	\$888.83
pewag HT Ladder - Duals	USA 4253 S	PAIR	\$1,212.29
pewag HT Ladder - Duals	USA 4253 SC	PAIR	\$1,212.29
pewag HT Ladder - Duals	USA 4255 S	PAIR	\$1,013.67
pewag HT Ladder - Duals	USA 4255 S 7ST	PAIR	\$1,162.54
pewag HT Ladder - Duals	USA 4255 SC	PAIR	\$1,013.67
pewag HT Ladder - Duals	USA 4255 SC 7ST	PAIR	\$1,215.67
pewag HT Ladder - Duals	USA 4257 S	PAIR	\$1,199.29

pewag HT Ladder - Duals	USA 4257 SC	PAIR	\$1,199.29
pewag HT Ladder - Duals	USA 4271 S	PAIR	\$1,546.93
pewag HT Ladder - Duals	USA 4271 SC	PAIR	\$1,546.93
pewag HT Ladder - Duals	USA 4273 S	PAIR	\$1,616.86
pewag HT Ladder - Duals	USA 4273 SC	PAIR	\$1,616.86
pewag mud service Duals	USA4412 S	PAIR	\$1,008.21
pewag mud service Duals	USA 4435 S	PAIR	\$1,216.33
pewag mud service Duals	USA 4437 S	PAIR	\$1,285.45
pewag mud service Duals	USA 4448 S	PAIR	\$1,340.73
pewag mud service Duals	USA 4448 SC	PAIR	\$1,340.73
pewag mud service Duals	USA 4461 S	PAIR	\$1,370.23
pewag mud service Duals	USA 4461 SC	PAIR	\$1,370.23
pewag mud service Duals	USA 4486 S	PAIR	\$1,686.81
pewag Cross Chains with Hooks	USA 6219	EACH	\$10.23
pewag Cross Chains with Hooks	USA 6221	EACH	\$11.48
pewag Cross Chains with Hooks	USA 6225	EACH	\$12.74
pewag Cross Chains with Hooks	USA 6229	EACH	\$14.00
pewag Cross Chains with Hooks	USA 6251	EACH	\$14.13
pewag Cross Chains with Hooks	USA 6251 7ST	EACH	\$22.24
pewag Cross Chains with Hooks	USA 6251 8ST	EACH	\$35.27
pewag Cross Chains with Hooks	USA 6253	EACH	\$15.84
pewag Cross Chains with Hooks	USA 6253 7ST	EACH	\$24.26
pewag Cross Chains with Hooks	USA 6253 8ST	EACH	\$38.48
pewag Cross Chains with Hooks	USA 6256 8.2mm	EACH	\$16.72
pewag Cross Chains with Hooks	USA 6259	EACH	\$17.55
pewag Cross Chains with Hooks	USA 6260	EACH	\$15.84
pewag Cross Chains with Hooks	USA 6263	EACH	\$17.55
pewag Cross Chains with Hooks	USA 6263 7ST	EACH	\$26.28
pewag Cross Chains with Hooks	USA 6263 8ST	EACH	\$41.69
pewag Cross Chains with Hooks	USA 6265	EACH	\$17.55
pewag Cross Chains with Hooks	USA 6266	EACH	\$19.25
pewag Cross Chains with Hooks	USA 6266 7ST	EACH	\$28.31
pewag Cross Chains with Hooks	USA 6266 8.2mm	EACH	\$24.33
pewag Cross Chains with Hooks	USA 6266 8ST	EACH	\$44.89
pewag Cross Chains with Hooks	USA 6267 7mm	EACH	\$28.81
pewag Cross Chains with Hooks	USA 6434 8.2mm	EACH	\$21.79
pewag Cross Chains with Hooks	USA 6445 8.2mm	EACH	\$24.33
pewag Cross Chains with Hooks	USA 6630 10mm	EACH	\$47.72
pewag Cross Chains with Hooks	USA 6630 12mm	EACH	\$67.23
pewag Cross Chains with Hooks	USA 6630 8.2mm	EACH	\$29.39
pewag Cross Chains with Hooks	USA 6640 10mm	EACH	\$52.64
pewag Cross Chains with Hooks	USA 6640 12mm	EACH	\$76.97
pewag Cross Chains with Hooks	USA 6650 10mm	EACH	\$62.49
pewag Cross Chains with Hooks	USA 6650 12mm	EACH	\$96.46
pewag Cross Chains with Hooks	USA 6660 10mm	EACH	\$72.33
pewag Cross Chains with Hooks	USA 6660 12mm	EACH	\$106.20
pewag Cross Chains with Hooks	USA 6670 10mm	EACH	\$82.18
pewag Cross Chains with Hooks	USA 6670 12mm	EACH	\$125.68
pewag Cross Chains with Hooks	USA 6680 10mm	EACH	\$92.02
pewag Cross Chains with Hooks	USA 6680 12mm	EACH	\$145.17
pewag Cross Chains with Hooks	USA 7213	EACH	\$19.25
pewag Cross Chains with Hooks	USA 7213 8ST	EACH	\$48.10
pewag Cross Chains with Hooks	USA 7214	EACH	\$20.96
pewag Cross Chains with Hooks	USA 7214 8ST	EACH	\$51.30

pewag Cross Chains with Hooks	USA 7215	EACH	\$22.67	
pewag Cross Chains with Hooks	USA 7215 8ST	EACH	\$54.51	
pewag Cross Chains with Hooks	USA 7216	EACH	\$26.08	
pewag Cross Chains with Hooks	USA 7420 10mm	EACH	\$42.80	
pewag Cross Chains with Hooks	USA 7420 8.2mm	EACH	\$26.86	
pewag Cross Chains with Hooks	USA 7426 10mm	EACH	\$52.64	
pewag Cross Chains with Hooks	USA 7426 8.2mm	EACH	\$31.93	
pewag CL-PSC	USA 91 PSC	PAIR	\$562.92	
pewag CL-PSC	USA 93 7 PSC	PAIR	\$565.76	
pewag CL-PSC	USA 94 PSC	PAIR	\$666.31	
pewag CL-PSC	USA 95 PSC	PAIR	\$675.43	
pewag Cross Chains with Hooks	USA 9562 10mm	EACH	\$62.49	
pewag Cross Chains with Hooks	USA 9562 12mm	EACH	\$86.71	
pewag Cross Chains with Hooks	USA 9567 10mm	EACH	\$72.33	
pewag Cross Chains with Hooks	USA 9567 12mm	EACH	\$106.20	
pewag CL-PSC	USA 97 PSC	PAIR	\$675.43	
pewag Forklift Chains	USA25015S 7mm	PAIR	\$323.71	
pewag Forklift Chains	USA28915S 5.6mm	PAIR	\$286.52	
pewag Forklift Chains	USA30015S 7mm DS	PAIR	\$614.07	
pewag Forklift Chains	USA65010S 4.5mm DS	PAIR	\$209.26	
pewag Forklift Chains	USA65010S 5.6mm DS	PAIR	\$279.02	
pewag Forklift Chains	USA65010S 7mm DS	PAIR	\$372.03	
pewag Forklift Chains	USA70012S 5.6mm DS	PAIR	\$331.96	
pewag Forklift Chains	USA70012S 7mm	PAIR	\$320.87	
pewag Forklift Chains	USA70012S 7mm DS	PAIR	\$609.66	
pewag Forklift Chains	USA70015S 5.6mm	PAIR	\$249.00	
pewag Skid Steer Chains - Ladder	USASSE 10165-2	PAIR	\$840.51	
pewag Skid Steer Chains - Ladder	USASSE 10165-4	PAIR	\$521.52	
pewag Skid Steer Chains - Ladder	USASSE 12165 PS	PAIR	\$872.93	
pewag Skid Steer Chains - Ladder	USASSE 12165 PSC	PAIR	\$872.93	
pewag Skid Steer Chains - Ladder	USASSE 12165-2	PAIR	\$899.93	
pewag Skid Steer Chains - Ladder	USASSE 12165-4	PAIR	\$578.02	
pewag Skid Steer Chains - Ladder	USASSE 14175-2	PAIR	\$1,132.96	
pewag Skid Steer Chains - Ladder	USASSE 14175-4	PAIR	\$674.66	
pewag Skid Steer Chains - Ladder	USASSE 3112165-2	PAIR	\$757.84	
pewag Skid Steer Chains - Ladder	USASSE 3112165-4	PAIR	\$520.21	
Pewag Zig Zag Chain	USA ZZ 2228 SC	PAIR	\$374.78	Items 14,15
Pewag Zig Zag Chain	USAZZ 2247 S 7	PAIR	\$493.02	
Pewag Zig Zag Chain	USAZZ 2247 S 7ST	PAIR	\$623.39	
Pewag Zig Zag Chain	USAZZ 2247 S 8ST	PAIR	\$772.47	
Pewag Zig Zag Chain	USAZZ 2247 SC 7	PAIR	\$526.37	
Pewag Zig Zag Chain	USAZZ 2247 SC 7ST	PAIR	\$645.19	
Pewag Zig Zag Chain	USAZZ 2247 SC 8ST	PAIR	\$788.27	
Pewag Zig Zag Chain	USAZZ 2249 S 7	PAIR	\$493.02	
Pewag Zig Zag Chain	USAZZ 2249 S 7ST	PAIR	\$649.35	
Pewag Zig Zag Chain	USAZZ 2249 S 8ST	PAIR	\$766.10	
Pewag Zig Zag Chain	USAZZ 2249 SC 7	PAIR	\$526.37	
Pewag Zig Zag Chain	USAZZ 2249 SC 7ST	PAIR	\$672.09	
Pewag Zig Zag Chain	USAZZ 2249 SC 8ST	PAIR	\$781.75	
Pewag Zig Zag Chain	USAZZ 2255 S 7	PAIR	\$546.89	
Pewag Zig Zag Chain	USAZZ 2255 S 7ST	PAIR	\$637.50	
Pewag Zig Zag Chain	USAZZ 2255 S 8ST	PAIR	\$808.33	
Pewag Zig Zag Chain	USAZZ 2255 SC 7	PAIR	\$560.92	
Pewag Zig Zag Chain	USAZZ 2255 SC 7ST	PAIR	\$654.23	

Pewag Zig Zag Chain	USAZZ 2255 SC 8ST	PAIR	\$829.06
Pewag Zig Zag Chain	USAZZ 3229 S 7	PAIR	\$383.13
Pewag Zig Zag Chain	USAZZ 3229 S 7ST	PAIR	\$506.42
Pewag Zig Zag Chain	USAZZ 3229 SC 7	PAIR	\$396.51
Pewag Zig Zag Chain	USAZZ 3229 SC 7ST	PAIR	\$526.32
Pewag Zig Zag Chain	USAZZ 3269 S 7	PAIR	\$542.80
Pewag Zig Zag Chain	USAZZ 3269 S 7ST	PAIR	\$766.19
Pewag Zig Zag Chain	USAZZ 3269 SC 7	PAIR	\$561.79
Pewag Zig Zag Chain	USAZZ 3269 SC 7ST	PAIR	\$784.95
pewag brenta-c 4x4	XMR69V	PAIR	\$305.01
pewag brenta-c 4x4	XMR 73 V	PAIR	\$305.01
pewag brenta-c 4x4	XMR 74 V	PAIR	\$305.01
pewag brenta-c 4x4	XMR 75 V	PAIR	\$328.47
pewag brenta-c 4x4	XMR 76 V	PAIR	\$328.47
pewag brenta-c 4x4	XMR 77 V	PAIR	\$328.47
pewag brenta-c 4x4	XMR 79 V	PAIR	\$328.47
pewag brenta-c 4x4	XMR 80 V	PAIR	\$360.74
pewag brenta-c 4x4	XMR 80A V	PAIR	\$360.74
pewag brenta-c 4x4	XMR 81 V	PAIR	\$360.74
pewag brenta-c 4x4	XMR 82 V	PAIR	\$360.74



pewag Traction Chain, Inc.
190 Greenhorn Drive
Pueblo, CO 81004
Phone: 719-623-5700
Fax: 719-694-1841
www.pewagchain.com

Technical Description

Starwave USA 5.6mm ladder chain

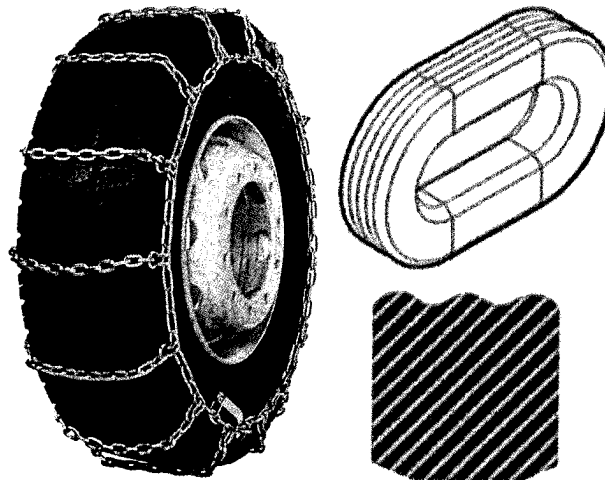

Chain Type:	Ladder style, reversible chain
Tread Net Links:	Square section material 5.6 mm, pitch 24 mm, with wave profile Chain links contain nickel & manganese alloy steel
Strength:	Minimum breaking stress of the tread net parts 300 N/mm ² , all other traction transferring chain parts have a minimum breaking stress of 200 N/mm ² . Connecting parts outside the tread net resist a stress of 80 N/mm ² .
Hardening:	Surface hardness 62 HRC minimum Core hardness 49 HRC minimum Case hardness 61 HRC minimum at 6% depth from link surface
Side Chain:	Inside: round link chain \varnothing 5.5mm, pitch 35 mm closed with end hook. Outside: round link chain \varnothing 5.5 mm, pitch 35 mm closed with tension lever.
Side Hook:	Connection to cross chains by means of side Hooks – \varnothing 7 x 35 mm

pewag



pewag Traction Chain, Inc.
190 Greenhorn Drive
Pueblo, CO 81004
Phone: 719-623-5700
Fax: 719-694-1841
www.pewagchain.com

Corrosion protection:	Zinc plated surface finish with a min. thickness of 5 μ m.
Tensioning S:	Tightened with tensioning lever and 'hanging back' link with safety device.
Tensioning SC:	Tightened with cams on the outer chain.
Size & ID marking:	The chain size stamped on tension lever (S) or cam (SC).
Mounting:	Standard 'throw over' fitting or with attached mounting cable and drive back. For closing the chain, a 1/4 rotation of the wheel is required anyway. Before mounting the chain the net must be arranged.
Packaging:	Packed in bag or box, with dimension tag and mounting instructions.
Features:	Easy to use. The special square section materials are designed so that they fit perfectly into the neighboring elements and thus provide torsional stiffness. Chains are repairable.
Product description:	The ladder style is a tested true design, combined with award winning performance to guarantee results.
Product details:	Assembled in the USA European Steel
Manufacturer:	ISO 9001 Certified ISO 14001 Certified Member of NACM (National Association of Chain Manufacturers)



**ISO 9001:2015
CERTIFICATE OF REGISTRATION**

This is to certify that

pewag



pewag Traction Chain

**190 Greenhorn Drive
Pueblo, CO 81004 USA**

**has successfully been assessed and found
to conform with the ISO 9001:2015
quality management system standard.**

The scope of this registration includes:

**Manufacture, Assembly, Warehousing, Sales,
and Distribution of Traction Chains**

Date of Registration: June 28, 2019

Date of Expiration: June 27, 2022

Date issued/revised : June 28, 2019

(Registered Since: March 15, 2017)

Certificate No. [REDACTED]

Steve Barfoot, President
Advantage International Registrar, Inc.





**ISO 14001:2015
CERTIFICATE OF REGISTRATION**

This is to certify that

pewäg



pewag Traction Chain

**190 Greenhorn Drive
Pueblo, CO 81004 USA**

**has successfully been assessed and found
to conform with the ISO 14001:2015
quality management system standard.**

The scope of this registration includes:

**Manufacture, Assembly, Warehousing, Sales,
and Distribution of Traction Chains**

Date of Registration: June 28, 2019

Date of Expiration: June 27, 2022

Date issued/revised : June 28, 2019

(Registered Since: March 15, 2017)

Certificate No. XXXXXXXXXX

Steve Barfoot, President
Advantage International Registrar, Inc.



ZERTIFIKAT ◆ CERTIFICATE ◆ 認証書 ◆ CERTIFICADO ◆ CERTIFICAT

MS01-0/02.15 A - Sonder



Landesgesellschaft
Österreich

CERTIFICATE

The Certification Body
of TÜV SÜD Landesgesellschaft Österreich GmbH
certifies that

pewag



pewag Schneeketten GmbH

Kettenwerk 1
A-9371 Brückl

Gaslaternenweg 4
A-8041 Graz

has established and applies
a Management System for

**Design, manufacture and sales of
snow chains, anti-skid chains, cross-country chains.
Surface and heat treatment, chain bends**

An audit was performed, Report No. **153987**
Proof has been furnished that the requirements
according to

ISO 9001:2015 and ISO 14001:2015

are fulfilled. The certificate is valid until **2021-12-31**

Certificate Registration No. XXXXXXXXXX

A. Kangerl

Vienna, 2018-12-17



Certification Body
of TÜV SÜD Landesgesellschaft Österreich GmbH
Franz-Grill-Straße 1 · Arsenal, Objekt 207, 1030 Vienna, Austria

TUV®

ZERTIFIKAT ♦ CERTIFICATE ♦ CERTIFICADO ♦ CERTIFICAT ♦
CERTIFIKAT ♦ 認証書 ♦ CERTIFICATE ♦ CERTIFICADO ♦ CERTIFICAT ♦

MS01-0/02.15 A - Sonder



Landesgesellschaft
Österreich

CERTIFICATE

The Certification Body
of TÜV SÜD Landesgesellschaft Österreich GmbH
certifies that

pewag



pewag Schneeketten GmbH

**Kettenwerk 1
A-9371 Brückl**

has established and applies
a Management System for

**Design, manufacture and sales of
snow chains, anti-skid chains, cross-country chains.
Surface and heat treatment, chain bends**

An audit was performed, Report No. **153987**
Proof has been furnished that the requirements
according to

ISO 50001:2011

are fulfilled. The certificate is valid until **2021-08-20**

Certificate Registration No. XXXXXXXXXX

A. Ranzger
Vienna, 2018-12-17



Certification Body
of TÜV SÜD Landesgesellschaft Österreich GmbH
Franz-Grill-Straße 1 · Arsenal, Objekt 207, 1030 Vienna, Austria

TÜV®

Technical Description

Chain: **pewag universal U**
 VKR 10

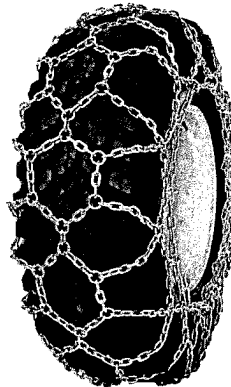

symbolpicture

- Chain Type:** Chain net with hexagonal pattern, reversible chain
- Tread Net Links:** Square section material with wave profile (VKR) 10 mm, pitch 35mm.
- Strength:** Minimum breaking stress of the tread net parts 300 N/mm², all other traction transferring chain parts have a minimum braking stress of 200 N/mm². Connecting parts outside the tread net resist a stress of 80 N/mm.
- Hardening:** Surface hardness 62 HRC minimum
Core hardness 49 HRC minimum
Case hardness 61 HRC minimum
6% case hardening depth
- Side Chain:** Inside: round link chain \varnothing 11 mm, pitch 39 mm closed with pewag end hook.
Outside: round link chain \varnothing 11 mm, pitch 39 mm closed with pewag end hook.
- Tread net closing hook:** drop forged hook.

pewag



pewag Schneeketten GmbH
A-8041 Graz, Gaslaternenweg 4
Phone: +43 50 50 11-0
Fax: +43 50 50 11-100
schneeketten@pewag.com
www.pewag.com

TBSK0018/2

- Rings:** Side chain rings - \varnothing 12 mm, pitch 45 mm
Cross part rings - \varnothing 12 mm, pitch 45 mm
- Corrosion protection:** Electrolytic galvanized surface finish with a min. thickness of 5 μ m.
- Tensioning:** Tension chain with depositing hook at loose end, led by slip through welded suspension rings, tightened with tensioning lever and 'hanging back' link with safety device.
- Size & ID marking:** The chain size stamped on 1st ring at the outside chain.
Chain ID is stamped on the 2nd ring.
- Packaging:** Packed in boxes, with dimension tag and spare parts bag (repair links and mounting chain).
- Features:** The special square section materials are designed so that they fit perfectly into the neighbouring elements and thus provide torsional stiffness.
- Application:** The popular pewag universal chain provides resistance and durability even in the toughest environment.
- Product description:** The pewag universal was designed specifically for heavy-duty use. pewag universal is made of TitanGrip® material. For wide-base tires, pewag offers a version with a staggered chain mesh. The wider chain mesh provides a higher wear resistance, longer life span and smoother running. These chains are marked by asterisk (*) in the dimension list.
Chain links contain nickel & manganese alloy steel



**STRONG
IS NOT
ENOUGH**
www.pewag.com

pewag Traction Chain, Inc.
190 Greenhorn Drive
Pueblo, CO 81004
Phone: 719-623-5700
Fax: 719-694-1841
www.pewagchain.com

Technical Description

Starwave USA zig zag chain

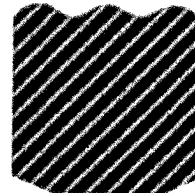
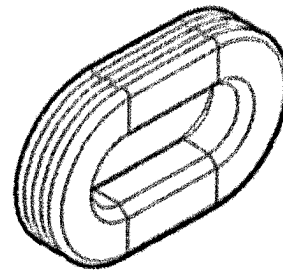
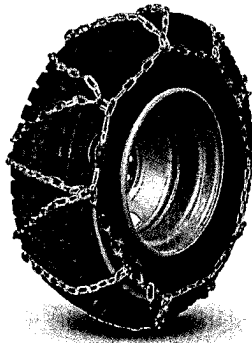

- Chain Type:** Zig Zag style, reversible chain
- Tread Net Links:** Square section material 7 mm, pitch 30 mm, with wave profile
Chain links contain nickel & manganese alloy steel
- Strength:** Minimum breaking stress of the tread net parts 300 N/mm², all other traction transferring chain parts have a minimum breaking stress of 200 N/mm². Connecting parts outside the tread net resist a stress of 80 N/mm².
- Hardening:** Surface hardness 62 HRC minimum
Core hardness 49 HRC minimum
Case hardness 61 HRC minimum at 6% depth from link surface
- Side Chain:** Inside: round link chain \varnothing 7mm, pitch 46 mm closed with end hook.
Outside: round link chain \varnothing 7 mm, pitch 46 mm closed with tension lever.
- Side Hook:** Connection to the cross chains by means of side Hooks – \varnothing 8 x 40 mm



pewag Traction Chain, Inc.
190 Greenhorn Drive
Pueblo, CO 81004
Phone: 719-623-5700
Fax: 719-694-1841
www.pewagchain.com

Corrosion protection:	Zinc plated surface finish with a min. thickness of 5 µm.
Tensioning S:	Tightened with tensioning lever and 'hanging back' link with safety device.
Tensioning SC:	Tightened with cams on the outer chain.
Size & ID marking:	The chain size stamped on tension lever (S) or cam (SC).
Mounting:	Standard 'throw over' fitting or with attached mounting cable and drive back. For closing the chain, a 1/4 rotation of the wheel is required anyway. Before mounting the chain the net must be arranged.
Packaging:	Packed in bag or box, with dimension tag and mounting instructions.
Features:	Easy to use. The special square section materials are designed so that they fit perfectly into the neighboring elements and thus provide torsional stiffness. Chains are repairable.
Product description:	The zig zag style is a tested true design, combined with award winning performance to guarantee results.
Product details:	Made in the USA USA Steel
Manufacturer:	ISO 9001 Certified ISO 14001 Certified Member of NACM (National Association of Chain Manufacturers)

pewag

**STRONG
IS NOT
TOUGH**

pewag Traction Chain, Inc.
190 Greenhorn Drive
Pueblo, CO 81004
Phone: 719-623-5700
Fax: 719-694-1841
www.pewagchain.com

Starwave USA pattern chain

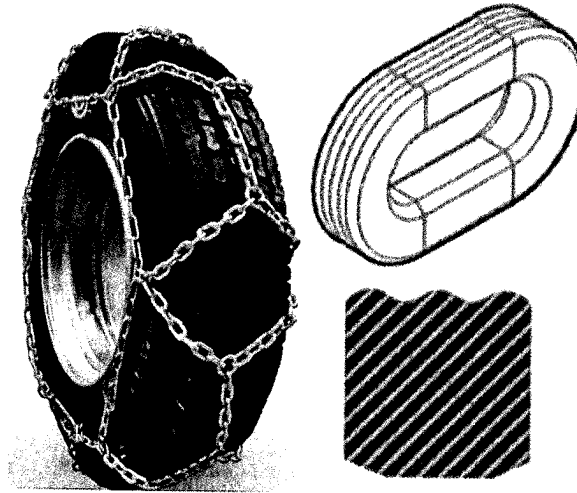

- Chain Type:** Pattern style, reversible chain.
- Tread Net Links:** Square section material 7 mm, pitch 30 mm, with wave profile.
Chain links contain nickel & manganese alloy steel
- Strength:** Minimum breaking stress of the tread net parts 300 N/mm², all other traction transferring chain parts have a minimum breaking stress of 200 N/mm². Connecting parts outside the cross chains resist a stress of 80 N/mm².
- Hardening:** Surface hardness 62 HRC minimum
Core hardness 49 HRC minimum
Case hardness 61 HRC minimum at 6% depth from link surface
- Side Chain:** Inside: round link chain \varnothing 6 mm, pitch 42 mm closed with end hook.
Outside: round link chain \varnothing 6 mm, pitch 42 mm closed with tension lever.



pewag Traction Chain, Inc.
190 Greenhorn Drive
Pueblo, CO 81004
Phone: 719-623-5700
Fax: 719-694-1841
www.pewagchain.com

Side Hook:	Connection to cross chains by means of side hooks – \varnothing 7 x 35 mm
Corrosion protection:	Zinc plated surface finish with a min. thickness of 5 μ m.
Tensioning S:	Tightened with tensioning lever and ‘hanging back’ link with safety device.
Tensioning SC:	Tightened with cams on the outer chain.
Size & ID marking:	The chain size stamped on cam.
Mounting:	Standard ‘throw over’ fitting. For closing the chain, a 1/4 rotation of the wheel is required. Before mounting the chain the net must be arranged.
Packaging:	Packed in bag or box, with dimension tag and mounting instructions.
Features:	Easy to use. The special square section materials are designed so that they fit perfectly into the neighboring elements and thus provide torsional stiffness. Chains are repairable.
Product description:	The pattern style is a tested true design, combined with award winning performance to guarantee results.
Product details:	Made in the USA USA Steel
Manufacturer:	ISO 9001 Certified ISO 14001 Certified Member of NACM (National Association of Chain Manufacturers)



pewag Traction Chain, Inc.
190 Greenhorn Drive
Pueblo, CO 81004
Phone: 719-623-5700
Fax: 719-694-1841
www.pewagchain.com

Technical Description

Starwave USA ladder chain

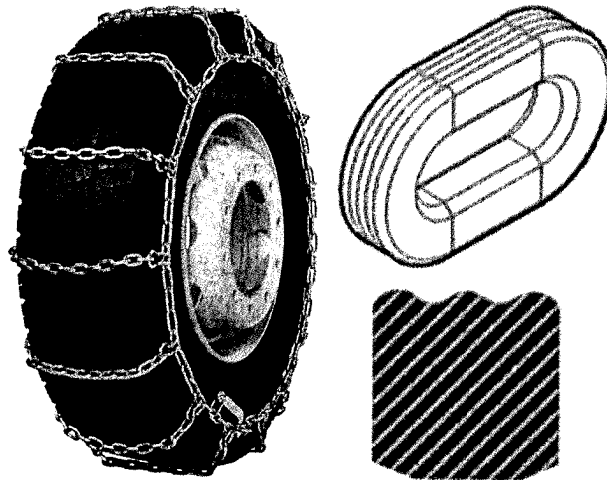

Chain Type:	Ladder style, reversible chain
Tread Net Links:	Square section material 7 mm, pitch 30 mm, with wave profile Chain links contain nickel & manganese alloy steel
Strength:	Minimum breaking stress of the tread net parts 300 N/mm ² , all other traction transferring chain parts have a minimum breaking stress of 200 N/mm ² . Connecting parts outside the tread net resist a stress of 80 N/mm ² .
Hardening:	Surface hardness 62 HRC minimum Core hardness 49 HRC minimum Case hardness 61 HRC minimum at 6% depth from link surface
Side Chain:	Inside: round link chain \varnothing 7mm, pitch 46 mm closed with end hook. Outside: round link chain \varnothing 7 mm, pitch 46 mm closed with tension lever.
Side Hook:	Connection to cross chains by means of side Hooks – \varnothing 8 x 40 mm



pewag Traction Chain, Inc.
190 Greenhorn Drive
Pueblo, CO 81004
Phone: 719-623-5700
Fax: 719-694-1841
www.pewagchain.com

- Corrosion protection:** Zinc plated surface finish with a min. thickness of 5 μ m.
- Tensioning S:** Tightened with tensioning lever and 'hanging back' link with safety device.
- Tensioning SC:** Tightened with cams on the outer chain.
- Size & ID marking:** The chain size stamped on tension lever (S) or cam (SC).
- Mounting:** Standard 'throw over' fitting or with attached mounting cable and drive back. For closing the chain, a 1/4 rotation of the wheel is required anyway. Before mounting the chain the net must be arranged.
- Packaging:** Packed in bag or box, with dimension tag and mounting instructions.
- Features:** Easy to use. The special square section materials are designed so that they fit perfectly into the neighboring elements and thus provide torsional stiffness. Chains are repairable.
- Product description:** The ladder style is a tested true design, combined with award winning performance to guarantee results.
- Product details:** Made in the USA
USA Steel
- Manufacturer:** ISO 9001 Certified
ISO 14001 Certified
Member of NACM (National Association of Chain Manufacturers)



pewag Traction Chain, Inc.
190 Greenhorn Drive
Pueblo, CO 81004
Phone: 719-623-5700
Fax: 719-694-1841
www.pewagchain.com

Technical Description

USA ladder chain

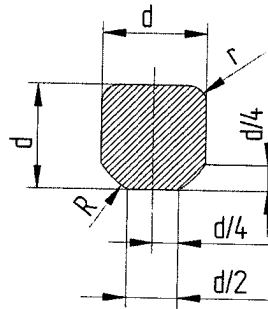
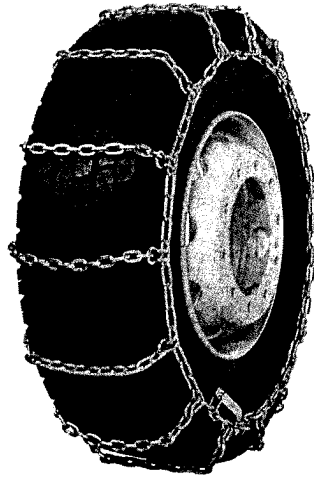

- Chain Type:** Ladder style, reversible chain
- Tread Net Links:** Square section material 10 mm, pitch 35 mm
Chain links contain nickel & manganese alloy steel
- Strength:** Minimum breaking stress of the tread net parts 300 N/mm², all other traction transferring chain parts have a minimum breaking stress of 200 N/mm². Connecting parts outside the tread net resist a stress of 80 N/mm².
- Hardening:** Surface hardness 62 HRC minimum
Core hardness 49 HRC minimum
Case hardness 61 HRC minimum at 6% depth from link surface
- Side Chains:** Round link chain \varnothing 9.53 mm, pitch 55.17 mm closed with tension lever.
- Side Hook:** Connection to cross chains by means of side Hooks – \varnothing 11 x 60 mm
- Corrosion protection:** Zinc plated surface finish with a min. thickness of 5 μ m.

pewag



pewag Traction Chain, Inc.
190 Greenhorn Drive
Pueblo, CO 81004
Phone: 719-623-5700
Fax: 719-694-1841
www.pewagchain.com

- Tensioning:** Tightened with tensioning lever
- Mounting:** Standard 'throw over' fitting or with attached mounting cable and drive back. For closing the chain, a 1/4 rotation of the wheel is required anyway. Before mounting the chain the net must be arranged.
- Packaging:** Packed in bag or box, with dimension tag and mounting instructions.
- Features:** Easy to use. The special square section materials are designed so that they fit perfectly into the neighboring elements and thus provide torsional stiffness. Chains are repairable.
- Product description:** The ladder style is a tested true design, combined with award winning performance to guarantee results.
- Product details:** Assembled in the USA
European steel
- Manufacturer:** ISO 9001 Certified
ISO 14001 Certified
Member of NACM (National Association of Chain Manufacturers)