

# Exhibit A Pricing Page

CRFQ DOT2000000028

Roadtec RP170e or Equal Extendable Width Wheeled Asphalt Paver

Item No.	Description:	Make/Model & Year	Estimated Unit Quantity	Unit Price	Item Total Cost
1	Extended width Wheeled Asphalt Paver	Vogele/S1703-3i 2020	10	\$ 336,000 <sup>00</sup>	\$ 3,360,000 <sup>00</sup>

Total Bid Amount 

Vendor Information

Company Name: Leslie Equipment Co.  
 Contract Manager: Paul Daniels  
 Address: 19 Goff Crossing Drive  
Cross Lanes WV 25313  
 Phone: 304-204-1818  
 Fax: 304-204-1811  
 Email: danielspaul@leec1.com  
 Signature: Paul Daniels

RECEIVED  
 2019 OCT 17 PM 1:23  
 WV PURCHASING  
 DIVISION



Purchasing Division  
 2019 Washington Street East  
 Post Office Box 50130  
 Charleston, WV 25305-0130

State of West Virginia  
 Request for Quotation  
 13 - Equipment

Proc Folder: 615049

Doc Description: ADDENDUM #4 ASPHALT PAVER (7020EC02)

Proc Type: Central Master Agreement

Date Issued	Solicitation Closes	Solicitation No	Version
2019-10-16	2019-10-17 13:30:00	CRFQ 0803 DOT2000000028	5

**BID RECEIVING LOCATION**

BID CLERK  
 DEPARTMENT OF ADMINISTRATION  
 PURCHASING DIVISION  
 2019 WASHINGTON ST E  
 CHARLESTON WV 25305  
 US

**VENDOR**

Vendor Name, Address and Telephone Number:

**LESLIE EQUIPMENT CO.  
 19 GOFF CROSSING DRIVE  
 CROSS LANES, WV 25313**

**FOR INFORMATION CONTACT THE BUYER**

Crystal G Husted  
 (304) 558-2402  
 crystal.g.husted@wv.gov

Signature X

FEIN #

55-0493180

DATE

10-16-19

All offers subject to all terms and conditions contained in this solicitation

STATE OF WEST VIRGINIA  
Purchasing Division

**PURCHASING AFFIDAVIT**

**CONSTRUCTION CONTRACTS:** Under W. Va. Code § 5-22-1(i), the contracting public entity shall not award a construction contract to any bidder that is known to be in default on any monetary obligation owed to the state or a political subdivision of the state, including, but not limited to, obligations related to payroll taxes, property taxes, sales and use taxes, fire service fees, or other fines or fees.

**ALL CONTRACTS:** Under W. Va. Code §5A-3-10a, no contract or renewal of any contract may be awarded by the state or any of its political subdivisions to any vendor or prospective vendor when the vendor or prospective vendor or a related party to the vendor or prospective vendor is a debtor and: (1) the debt owed is an amount greater than one thousand dollars in the aggregate; or (2) the debtor is in employer default.

**EXCEPTION:** The prohibition listed above does not apply where a vendor has contested any tax administered pursuant to chapter eleven of the W. Va. Code, workers' compensation premium, permit fee or environmental fee or assessment and the matter has not become final or where the vendor has entered into a payment plan or agreement and the vendor is not in default of any of the provisions of such plan or agreement.

**DEFINITIONS:**

"Debt" means any assessment, premium, penalty, fine, tax or other amount of money owed to the state or any of its political subdivisions because of a judgment, fine, permit violation, license assessment, defaulted workers' compensation premium, penalty or other assessment presently delinquent or due and required to be paid to the state or any of its political subdivisions, including any interest or additional penalties accrued thereon.

"Employer default" means having an outstanding balance or liability to the old fund or to the uninsured employers' fund or being in policy default, as defined in W. Va. Code § 23-2c-2, failure to maintain mandatory workers' compensation coverage, or failure to fully meet its obligations as a workers' compensation self-insured employer. An employer is not in employer default if it has entered into a repayment agreement with the Insurance Commissioner and remains in compliance with the obligations under the repayment agreement.

"Related party" means a party, whether an individual, corporation, partnership, association, limited liability company or any other form or business association or other entity whatsoever, related to any vendor by blood, marriage, ownership or contract through which the party has a relationship of ownership or other interest with the vendor so that the party will actually or by effect receive or control a portion of the benefit, profit or other consideration from performance of a vendor contract with the party receiving an amount that meets or exceeds five percent of the total contract amount.

**AFFIRMATION:** By signing this form, the vendor's authorized signer affirms and acknowledges under penalty of law for false swearing (W. Va. Code §61-5-3) that: (1) for construction contracts, the vendor is not in default on any monetary obligation owed to the state or a political subdivision of the state, and (2) for all other contracts, that neither vendor nor any related party owe a debt as defined above and that neither vendor nor any related party are in employer default as defined above, unless the debt or employer default is permitted under the exception above.

**WITNESS THE FOLLOWING SIGNATURE:**

Vendor's Name: Leslie Equipment Co.

Authorized Signature: [Signature] Date: 10-11-2019

State of West Virginia

County of Kanawha, to-wit:

Taken, subscribed, and sworn to before me this 11<sup>th</sup> day of October, 2019.

My Commission expires October 19, 2019.

**AFFIX SEAL HERE**

NOTARY PUBLIC [Signature]

*Purchasing Affidavit (Revised 01/19/2018)*

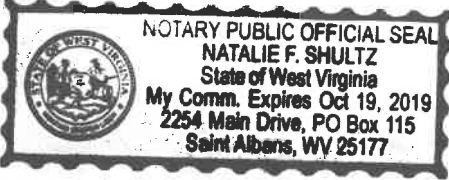

West Virginia Ethics Commission  
**Disclosure of Interested Parties to Contracts**

(Required by W. Va. Code § 6D-1-2)

Name of Contracting Business Entity: Leslie Equipment Co. Address: 19 Goff Crossing Drive  
Cross Lanes WV 25313

Name of Authorized Agent: Paul Daniels Address: 19 Goff Crossing Drive Cross Lanes WV 25313

Contract Number: DOT2000000028 Contract Description: Asphalt Paver

Governmental agency awarding contract: \_\_\_\_\_

Check here if this is a Supplemental Disclosure

List the Names of Interested Parties to the contract which are known or reasonably anticipated by the contracting business entity for each category below (attach additional pages if necessary):

1. Subcontractors or other entities performing work or service under the Contract

Check here if none, otherwise list entity/individual names below.

2. Any person or entity who owns 25% or more of contracting entity (not applicable to publicly traded entities)

Check here if none, otherwise list entity/individual names below.

John D Leslie

3. Any person or entity that facilitated, or negotiated the terms of, the applicable contract (excluding legal services related to the negotiation or drafting of the applicable contract)

Check here if none, otherwise list entity/individual names below.

Signature: Paul Daniels

Date Signed: 10-11-2019

**Notary Verification**

State of West Virginia, County of Kanawha:

I, Paul Daniels, the authorized agent of the contracting business entity listed above, being duly sworn, acknowledge that the Disclosure herein is being made under oath and under the penalty of perjury.

Taken, sworn to and subscribed before me this 11<sup>th</sup> day of October, 2019.

Natalie F Shultz  
Notary Public's Signature

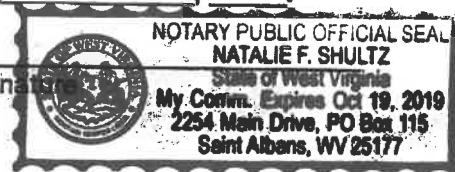

**To be completed by State Agency:**

Date Received by State Agency: \_\_\_\_\_

Date submitted to Ethics Commission: \_\_\_\_\_

Governmental agency submitting Disclosure: \_\_\_\_\_

**DESIGNATED CONTACT:** Vendor appoints the individual identified in this Section as the Contract Administrator and the initial point of contact for matters relating to this Contract.

Paul Daniels Sales Rep.  
(Name, Title)  
Paul Daniels Sales Rep.  
(Printed Name and Title)  
19 Goff Crossing Drive Cross Lanes WV 25313  
(Address)  
304-204-1818 / 304-204-1811  
(Phone Number) / (Fax Number)  
danielspaul@lec1.com  
(email address)

**CERTIFICATION AND SIGNATURE:** By signing below, or submitting documentation through wvOASIS, I certify that I have reviewed this Solicitation in its entirety; that I understand the requirements, terms and conditions, and other information contained herein; that this bid, offer or proposal constitutes an offer to the State that cannot be unilaterally withdrawn; that the product or service proposed meets the mandatory requirements contained in the Solicitation for that product or service, unless otherwise stated herein; that the Vendor accepts the terms and conditions contained in the Solicitation, unless otherwise stated herein; that I am submitting this bid, offer or proposal for review and consideration; that I am authorized by the vendor to execute and submit this bid, offer, or proposal, or any documents related thereto on vendor's behalf; that I am authorized to bind the vendor in a contractual relationship; and that to the best of my knowledge, the vendor has properly registered with any State agency that may require registration.

Leslie Equipment Co.  
(Company)  
Paul Daniels Paul Daniels Sales Rep.  
(Authorized Signature) (Representative Name, Title)  
Paul Daniels Sales Rep.  
(Printed Name and Title of Authorized Representative)  
10-11-2019  
(Date)  
304-204-1818 / 304-204-1811  
(Phone Number) (Fax Number)

**REQUEST FOR QUOTATION**  
**CRFQ DOT2000000028**  
**(WVDOH CLASS 503) Extendable width Wheeled Asphalt Paver**  
**ROADTEC RP170e or Equal (7020EC02)**

---

**8.2 Reports:** Vendor shall provide quarterly reports and annual summaries to the Agency showing the Agency's items purchased, quantities of items purchased, and total dollar value of the items purchased. Vendor shall also provide reports, upon request, showing the items purchased during the term of this Contract, the quantity purchased for each of those items, and the total value of purchases for each of those items. Failure to supply such reports may be grounds for cancellation of this Contract.

**8.3 Contract Manager:** During its performance of this Contract, Vendor must designate and maintain a primary contract manager responsible for overseeing Vendor's responsibilities under this Contract. The Contract manager must be available during normal business hours to address any customer service or other issues related to this Contract. Vendor should list its Contract manager and his or her contact information below.

**Contract Manager:** Paul Daniels  
**Telephone Number:** 304-204-1818  
**Fax Number:** 304-204-1811  
**Email Address:** danielspaul@lec1.com

**ADDENDUM ACKNOWLEDGEMENT FORM**  
**SOLICITATION NO.: DOT2000000028**

**Instructions:** Please acknowledge receipt of all addenda issued with this solicitation by completing this addendum acknowledgment form. Check the box next to each addendum received and sign below. Failure to acknowledge addenda may result in bid disqualification.

**Acknowledgment:** I hereby acknowledge receipt of the following addenda and have made the necessary revisions to my proposal, plans and/or specification, etc.

**Addendum Numbers Received:**

(Check the box next to each addendum received)

- |  |  |
|--|--|
| <input checked="" type="checkbox"/> Addendum No. 1 | <input type="checkbox"/> Addendum No. 6  |
| <input checked="" type="checkbox"/> Addendum No. 2 | <input type="checkbox"/> Addendum No. 7  |
| <input checked="" type="checkbox"/> Addendum No. 3 | <input type="checkbox"/> Addendum No. 8  |
| <input checked="" type="checkbox"/> Addendum No. 4 | <input type="checkbox"/> Addendum No. 9  |
| <input type="checkbox"/> Addendum No. 5            | <input type="checkbox"/> Addendum No. 10 |

I understand that failure to confirm the receipt of addenda may be cause for rejection of this bid. I further understand that any verbal representation made or assumed to be made during any oral discussion held between Vendor's representatives and any state personnel is not binding. Only the information issued in writing and added to the specifications by an official addendum is binding.

Leslie Equipment Co  
Company

[Signature]  
Authorized Signature

10-16-19  
Date

**NOTE:** This addendum acknowledgement should be submitted with the bid to expedite document processing.  
Revised 6/8/2012

ADDENDUM ACKNOWLEDGEMENT FORM  
SOLICITATION NO.: CRFQ DOT2000000028

Instructions: Please acknowledge receipt of all addenda issued with this solicitation by completing this addendum acknowledgment form. Check the box next to each addendum received and sign below. Failure to acknowledge addenda may result in bid disqualification.

Acknowledgment: I hereby acknowledge receipt of the following addenda and have made the necessary revisions to my proposal, plans and/or specification, etc.

Addendum Numbers Received:

(Check the box next to each addendum received)

- Addendum No. 1
- Addendum No. 2
- Addendum No. 3
- Addendum No. 4
- Addendum No. 5

- Addendum No. 6
- Addendum No. 7
- Addendum No. 8
- Addendum No. 9
- Addendum No. 10

I understand that failure to confirm the receipt of addenda may be cause for rejection of this bid. I further understand that any verbal representation made or assumed to be made during any oral discussion held between Vendor's representatives and any state personnel is not binding. Only the information issued in writing and added to the specifications by an official addendum is binding.

Leslie Equipment Co.  
Company

Paul Daniels  
Authorized Signature

10-11-2019  
Date

NOTE: This addendum acknowledgment should be submitted with the bid to expedite document processing.





Purchasing Division  
 2019 Washington Street East  
 Post Office Box 50130  
 Charleston, WV 25305-0130

State of West Virginia  
 Request for Quotation  
 13 - Equipment

Proc Folder: 615049

Doc Description: ASPHALT PAVER (7020EC02)

Proc Type: Central Master Agreement

Date Issued	Solicitation Closes	Solicitation No	Version
2019-08-22	2019-10-08 13:30:00	CRFQ 0803 DOT2000000028	1

**BID RECEIVING LOCATION**

BID CLERK  
 DEPARTMENT OF ADMINISTRATION  
 PURCHASING DIVISION  
 2019 WASHINGTON ST E  
 CHARLESTON WV 25305  
 US

**VENDOR**

Vendor Name, Address and Telephone Number:

**LESLIE EQUIPMENT CO.  
 19 GOFF CROSSING DRIVE  
 CROSS LANES, WV 25313**

**FOR INFORMATION CONTACT THE BUYER**

Crystal G Hustead  
 (304) 558-2402  
 crystal.g.hustead@wv.gov

Signature X

FEIN #

55-0493180

DATE

10-11-2019

All offers subject to all terms and conditions contained in this solicitation

**ADDITIONAL INFORMATION:**

THE STATE OF WEST VIRGINIA PURCHASING DIVISION FOR THE AGENCY, WEST VIRGINIA DIVISION OF HIGHWAYS, IS SOLICITING BIDS TO ESTABLISH AN OPEN-END CONTRACT FOR ROADTEC RP170E OR EQUAL ASPHALT PAVER 8-FOOT TO 15-FOOT EXTENDIBLE WIDTH PER THE ATTACHED DOCUMENTS.

QUESTIONS REGARDING THE SOLICITATION MUST BE SUBMITTED IN WRITING TO CRYSTAL.G.HUSTEAD@WV.GOV PRIOR TO THE QUESTION PERIOD DEADLINE CONTAINED IN THE INSTRUCTIONS TO VENDORS SUBMITTING BIDS.

INVOICE TO	SHIP TO
DIVISION OF HIGHWAYS EQUIPMENT DIVISION RT 33 83 BRUSHY ROAD CROSSING, PO BOX 610 BUCKHANNON WV26201 US	DIVISION OF HIGHWAYS EQUIPMENT DIVISION 83 BRUSHY FORK RD CROSSING BUCKHANNON WV 26201 US

Line	Comm Ln Desc	Qty	Unit Issue	Unit Price	Total Price
1	Asphalt Paver	10.00000	EA		

Comm Code	Manufacturer	Specification	Model #
22101607			

**Extended Description :**

Extendable width wheeled asphalt paver, Roadtec RP170e or equal

**SCHEDULE OF EVENTS**

Line	Event	Event Date
1	MANDATORY PRE-BID MEETING	2019-09-12
2	VENDOR QUESTION DEADLINE	2019-09-23

**ADDITIONAL INFORMATION:**

Addendum #4 is issued for following reasons:

1. To clarify specification 3.2.6.2

No other changes

INVOICE TO	SHIP TO
DIVISION OF HIGHWAYS EQUIPMENT DIVISION RT 33 83 BRUSHY ROAD CROSSING, PO BOX 610 BUCKHANNON WV26201 US	DIVISION OF HIGHWAYS EQUIPMENT DIVISION 83 BRUSHY FORK RD CROSSING BUCKHANNON WV 26201 US

Line	Comm Ln Desc	Qty	Unit Issue	Unit Price	Total Price
1	Asphalt Paver	10.00000	EA		

Comm Code	Manufacturer	Specification	Model #
22101607			

**Extended Description :**

Extendable width wheeled asphalt paver, Roadtec RP170e or equal

**SCHEDULE OF EVENTS**

Line	Event	Event Date
1	MANDATORY PRE-BID MEETING	2019-09-12
2	VENDOR QUESTION DEADLINE	2019-09-23

**SOLICITATION NUMBER: CRFQ DOT2000000028**  
**Addendum Number: 4**

---

The purpose of this addendum is to modify the solicitation identified as ("Solicitation") to reflect the change(s) identified and described below.

**Applicable Addendum Category:**

- Modify bid opening date and time
- Modify specifications of product or service being sought
- Attachment of vendor questions and responses
- Attachment of pre-bid sign-in sheet
- Correction of error
- Other

**Description of Modification to Solicitation:**

1. To clarify specification 3.2.6.2

No other changes

Bid opening remains October 17, 2019 at 1:30 PM

**Additional Documentation:** Documentation related to this Addendum (if any) has been included herewith as Attachment A and is specifically incorporated herein by reference.

**Terms and Conditions:**

1. All provisions of the Solicitation and other addenda not modified herein shall remain in full force and effect.
2. Vendor should acknowledge receipt of all addenda issued for this Solicitation by completing an Addendum Acknowledgment, a copy of which is included herewith. Failure to acknowledge addenda may result in bid disqualification. The addendum acknowledgement should be submitted with the bid to expedite document processing.

# ATTACHMENT A

**CRFQ DOT2000000028**  
**Addendum 4**

Clarification:

**3.2.6.2 Full 5-year 6000 hours on Engine and emissions 100% parts and labor on 6-cylinder engine and 7-year 8000 hours on Engine and emissions on 4-cylinder engine 100% parts and labor.**

**Specification shall remain as written**

## INSTRUCTIONS TO VENDORS SUBMITTING BIDS

**1. REVIEW DOCUMENTS THOROUGHLY:** The attached documents contain a solicitation for bids. Please read these instructions and all documents attached in their entirety. These instructions provide critical information about requirements that if overlooked could lead to disqualification of a Vendor's bid. All bids must be submitted in accordance with the provisions contained in these instructions and the Solicitation. Failure to do so may result in disqualification of Vendor's bid.

**2. MANDATORY TERMS:** The Solicitation may contain mandatory provisions identified by the use of the words "must," "will," and "shall." Failure to comply with a mandatory term in the Solicitation will result in bid disqualification.

**3. PREBID MEETING:** The item identified below shall apply to this Solicitation.

A pre-bid meeting will not be held prior to bid opening

A **MANDATORY PRE-BID** meeting will be held at the following place and time:

Date and Time: September 12, 2019 at 11:30 AM EST

Location:

1900 Kanawha Blvd, East

Building 5, Room A-122

Charleston, WV 25305

All Vendors submitting a bid must attend the mandatory pre-bid meeting. Failure to attend the mandatory pre-bid meeting shall result in disqualification of the Vendor's bid. No one person attending the pre-bid meeting may represent more than one Vendor.

An attendance sheet provided at the pre-bid meeting shall serve as the official document verifying attendance. The State will not accept any other form of proof or documentation to verify attendance. Any person attending the pre-bid meeting on behalf of a Vendor must list on the attendance sheet his or her name and the name of the Vendor he or she is representing.

Additionally, the person attending the pre-bid meeting should include the Vendor's E-Mail address, phone number, and Fax number on the attendance sheet. It is the Vendor's responsibility to locate the attendance sheet and provide the required information. Failure to complete the attendance sheet as required may result in disqualification of Vendor's bid.

All Vendors should arrive prior to the starting time for the pre-bid. Vendors who arrive after the starting time but prior to the end of the pre-bid will be permitted to sign in, but are charged with knowing all matters discussed at the pre-bid.

Questions submitted at least five business days prior to a scheduled pre-bid will be discussed at the pre-bid meeting if possible. Any discussions or answers to questions at the pre-bid meeting are preliminary in nature and are non-binding. Official and binding answers to questions will be published in a written addendum to the Solicitation prior to bid opening.

**4. VENDOR QUESTION DEADLINE:** Vendors may submit questions relating to this Solicitation to the Purchasing Division. Questions must be submitted in writing. All questions must be submitted on or before the date listed below and to the address listed below in order to be considered. A written response will be published in a Solicitation addendum if a response is possible and appropriate. Non-written discussions, conversations, or questions and answers regarding this Solicitation are preliminary in nature and are nonbinding.

Submitted e-mails should have solicitation number in the subject line.

Question Submission Deadline: **September 23, 2019 at 10:00 AM EST**

Submit Questions to: **Crystal Husted**

2019 Washington Street, East

Charleston, WV 25305

Fax: (304) 558-4115 (Vendors should not use this fax number for bid submission)

Email: [Crystal.G.Husted@wv.gov](mailto:Crystal.G.Husted@wv.gov)

**5. VERBAL COMMUNICATION:** Any verbal communication between the Vendor and any State personnel is not binding, including verbal communication at the mandatory pre-bid conference. Only information issued in writing and added to the Solicitation by an official written addendum by the Purchasing Division is binding.

**6. BID SUBMISSION:** All bids must be submitted electronically through wvOASIS or signed and delivered by the Vendor to the Purchasing Division at the address listed below on or before the date and time of the bid opening. Any bid received by the Purchasing Division staff is considered to be in the possession of the Purchasing Division and will not be returned for any reason. The Purchasing Division will not accept bids, modification of bids, or addendum acknowledgment forms via e-mail. Acceptable delivery methods include electronic submission via wvOASIS, hand delivery, delivery by courier, or facsimile.

The bid delivery address is:

Department of Administration, Purchasing Division

2019 Washington Street East

Charleston, WV 25305-0130

A bid that is not submitted electronically through wvOASIS should contain the information listed below on the face of the envelope or the bid may be rejected by the Purchasing Division.:

**SEALED BID:**

**BUYER:** Crystal Husted

**SOLICITATION NO.:** CRFQ DOT2000000028

**BID OPENING DATE:** October 8, 2019

**BID OPENING TIME:** 1:30 PM EST

**FAX NUMBER:** 304-558-3970



The Purchasing Division may prohibit the submission of bids electronically through wvOASIS at its sole discretion. Such a prohibition will be contained and communicated in the wvOASIS system resulting in the Vendor's inability to submit bids through wvOASIS. Submission of a response to an Expression or Interest or Request for Proposal is not permitted in wvOASIS.

**For Request For Proposal ("RFP") Responses Only:** In the event that Vendor is responding to a request for proposal, the Vendor shall submit one original technical and one original cost proposal plus       n/a       convenience copies of each to the Purchasing Division at the address shown above. Additionally, the Vendor should identify the bid type as either a technical or cost proposal on the face of each bid envelope submitted in response to a request for proposal as follows:

**BID TYPE:** (This only applies to CRFP)

Technical

Cost

**7. BID OPENING:** Bids submitted in response to this Solicitation will be opened at the location identified below on the date and time listed below. Delivery of a bid after the bid opening date and time will result in bid disqualification. For purposes of this Solicitation, a bid is considered delivered when confirmation of delivery is provided by wvOASIS (in the case of electronic submission) or when the bid is time stamped by the official Purchasing Division time clock (in the case of hand delivery).

**Bid Opening Date and Time:** October 8, 2019 at 1:30 PM EST

**Bid Opening Location:** Department of Administration, Purchasing Division  
2019 Washington Street East  
Charleston, WV 25305-0130

**8. ADDENDUM ACKNOWLEDGEMENT:** Changes or revisions to this Solicitation will be made by an official written addendum issued by the Purchasing Division. Vendor should acknowledge receipt of all addenda issued with this Solicitation by completing an Addendum Acknowledgment Form, a copy of which is included herewith. Failure to acknowledge addenda may result in bid disqualification. The addendum acknowledgement should be submitted with the bid to expedite document processing.

**9. BID FORMATTING:** Vendor should type or electronically enter the information onto its bid to prevent errors in the evaluation. Failure to type or electronically enter the information may result in bid disqualification.

**10. ALTERNATE MODEL OR BRAND:** Unless the box below is checked, any model, brand, or specification listed in this Solicitation establishes the acceptable level of quality only and is not intended to reflect a preference for, or in any way favor, a particular brand or vendor. Vendors may bid alternates to a listed model or brand provided that the alternate is at least equal to the model or brand and complies with the required specifications. The equality of any alternate being bid shall be determined by the State at its sole discretion. Any Vendor bidding an alternate model or brand should clearly identify the alternate items in its bid and should include manufacturer's specifications, industry literature, and/or any other relevant documentation demonstrating the

equality of the alternate items. Failure to provide information for alternate items may be grounds for rejection of a Vendor's bid.

This Solicitation is based upon a standardized commodity established under W. Va. Code § 5A-3-61. Vendors are expected to bid the standardized commodity identified. Failure to bid the standardized commodity will result in your firm's bid being rejected.

**11. EXCEPTIONS AND CLARIFICATIONS:** The Solicitation contains the specifications that shall form the basis of a contractual agreement. Vendor shall clearly mark any exceptions, clarifications, or other proposed modifications in its bid. Exceptions to, clarifications of, or modifications of a requirement or term and condition of the Solicitation may result in bid disqualification.

**12. COMMUNICATION LIMITATIONS:** In accordance with West Virginia Code of State Rules §148-1-6.6, communication with the State of West Virginia or any of its employees regarding this Solicitation during the solicitation, bid, evaluation or award periods, except through the Purchasing Division, is strictly prohibited without prior Purchasing Division approval. Purchasing Division approval for such communication is implied for all agency delegated and exempt purchases.

**13. REGISTRATION:** Prior to Contract award, the apparent successful Vendor must be properly registered with the West Virginia Purchasing Division and must have paid the \$125 fee, if applicable.

**14. UNIT PRICE:** Unit prices shall prevail in cases of a discrepancy in the Vendor's bid.

**15. PREFERENCE:** Vendor Preference may be requested in purchases of motor vehicles or construction and maintenance equipment and machinery used in highway and other infrastructure projects. Any request for preference must be submitted in writing with the bid, must specifically identify the preference requested with reference to the applicable subsection of West Virginia Code § 5A-3-37, and should include with the bid any information necessary to evaluate and confirm the applicability of the requested preference. A request form to help facilitate the request can be found at:

<http://www.state.wv.us/admin/purchase/vrc/Venpref.pdf>.

**15A. RECIPROCAL PREFERENCE:** The State of West Virginia applies a reciprocal preference to all solicitations for commodities and printing in accordance with W. Va. Code § 5A-3-37(b). In effect, non-resident vendors receiving a preference in their home states, will see that same preference granted to West Virginia resident vendors bidding against them in West Virginia. A request form to help facilitate the request can be found at:

<http://www.state.wv.us/admin/purchase/vrc/Venpref.pdf>.

**16. SMALL, WOMEN-OWNED, OR MINORITY-OWNED BUSINESSES:** For any solicitations publicly advertised for bid, in accordance with West Virginia Code §5A-3-37(a)(7) and W. Va. CSR § 148-22-9, any non-resident vendor certified as a small, women-owned, or minority-owned business under W. Va. CSR § 148-22-9 shall be provided the same preference made available to any resident vendor. Any non-resident small, women-owned, or minority-owned business must identify itself as such in writing, must submit that writing to the

Purchasing Division with its bid, and must be properly certified under W. Va. CSR § 148-22-9 prior to contract award to receive the preferences made available to resident vendors. Preference for a non-resident small, women-owned, or minority owned business shall be applied in accordance with W. Va. CSR § 148-22-9.

**17. WAIVER OF MINOR IRREGULARITIES:** The Director reserves the right to waive minor irregularities in bids or specifications in accordance with West Virginia Code of State Rules § 148-1-4.6.

**18. ELECTRONIC FILE ACCESS RESTRICTIONS:** Vendor must ensure that its submission in wvOASIS can be accessed and viewed by the Purchasing Division staff immediately upon bid opening. The Purchasing Division will consider any file that cannot be immediately accessed and viewed at the time of the bid opening (such as, encrypted files, password protected files, or incompatible files) to be blank or incomplete as context requires, and are therefore unacceptable. A vendor will not be permitted to unencrypt files, remove password protections, or resubmit documents after bid opening to make a file viewable if those documents are required with the bid. A Vendor may be required to provide document passwords or remove access restrictions to allow the Purchasing Division to print or electronically save documents provided that those documents are viewable by the Purchasing Division prior to obtaining the password or removing the access restriction.

**19. NON-RESPONSIBLE:** The Purchasing Division Director reserves the right to reject the bid of any vendor as Non-Responsible in accordance with W. Va. Code of State Rules § 148-1-5.3, when the Director determines that the vendor submitting the bid does not have the capability to fully perform, or lacks the integrity and reliability to assure good-faith performance.”

**20. ACCEPTANCE/REJECTION:** The State may accept or reject any bid in whole, or in part in accordance with W. Va. Code of State Rules § 148-1-4.5. and § 148-1-6.4.b.”

**21. YOUR SUBMISSION IS A PUBLIC DOCUMENT:** Vendor’s entire response to the Solicitation and the resulting Contract are public documents. As public documents, they will be disclosed to the public following the bid/proposal opening or award of the contract, as required by the competitive bidding laws of West Virginia Code §§ 5A-3-1 et seq., 5-22-1 et seq., and 5G-1-1 et seq. and the Freedom of Information Act West Virginia Code §§ 29B-1-1 et seq.

**DO NOT SUBMIT MATERIAL YOU CONSIDER TO BE CONFIDENTIAL, A TRADE SECRET, OR OTHERWISE NOT SUBJECT TO PUBLIC DISCLOSURE.**

Submission of any bid, proposal, or other document to the Purchasing Division constitutes your explicit consent to the subsequent public disclosure of the bid, proposal, or document. The Purchasing Division will disclose any document labeled “confidential,” “proprietary,” “trade secret,” “private,” or labeled with any other claim against public disclosure of the documents, to include any “trade secrets” as defined by West Virginia Code § 47-22-1 et seq. All submissions are subject to public disclosure without notice.

**22. INTERESTED PARTY DISCLOSURE:** West Virginia Code § 6D-1-2 requires that the vendor submit to the Purchasing Division a disclosure of interested parties to the contract for all contracts with an actual or estimated value of at least \$1 Million. That disclosure must occur on the form prescribed and approved by the WV Ethics Commission prior to contract award. A copy of that form is included with this solicitation or can be obtained from the WV Ethics Commission. This requirement does not apply to publicly traded companies listed on a national or international stock exchange. A more detailed definition of interested parties can be obtained from the form referenced above.

**23. WITH THE BID REQUIREMENTS:** In instances where these specifications require documentation or other information with the bid, and a vendor fails to provide it with the bid, the Director of the Purchasing Division reserves the right to request those items after bid opening and prior to contract award pursuant to the authority to waive minor irregularities in bids or specifications under W. Va. CSR § 148-1-4.6. This authority does not apply to instances where state law mandates receipt with the bid.

## **GENERAL TERMS AND CONDITIONS:**

**1. CONTRACTUAL AGREEMENT:** Issuance of a Award Document signed by the Purchasing Division Director, or his designee, and approved as to form by the Attorney General's office constitutes acceptance of this Contract made by and between the State of West Virginia and the Vendor. Vendor's signature on its bid signifies Vendor's agreement to be bound by and accept the terms and conditions contained in this Contract.

**2. DEFINITIONS:** As used in this Solicitation/Contract, the following terms shall have the meanings attributed to them below. Additional definitions may be found in the specifications included with this Solicitation/Contract.

**2.1. "Agency" or "Agencies"** means the agency, board, commission, or other entity of the State of West Virginia that is identified on the first page of the Solicitation or any other public entity seeking to procure goods or services under this Contract.

**2.2. "Bid" or "Proposal"** means the vendors submitted response to this solicitation.

**2.3. "Contract"** means the binding agreement that is entered into between the State and the Vendor to provide the goods or services requested in the Solicitation.

**2.4. "Director"** means the Director of the West Virginia Department of Administration, Purchasing Division.

**2.5. "Purchasing Division"** means the West Virginia Department of Administration, Purchasing Division.

**2.6. "Award Document"** means the document signed by the Agency and the Purchasing Division, and approved as to form by the Attorney General, that identifies the Vendor as the contract holder.

**2.7. "Solicitation"** means the official notice of an opportunity to supply the State with goods or services that is published by the Purchasing Division.

**2.8. "State"** means the State of West Virginia and/or any of its agencies, commissions, boards, etc. as context requires.

**2.9. "Vendor" or "Vendors"** means any entity submitting a bid in response to the Solicitation, the entity that has been selected as the lowest responsible bidder, or the entity that has been awarded the Contract as context requires.

**3. CONTRACT TERM; RENEWAL; EXTENSION:** The term of this Contract shall be determined in accordance with the category that has been identified as applicable to this Contract below:

**Term Contract**

**Initial Contract Term:** **Initial Contract Term:** This Contract becomes effective on \_\_\_\_\_  
Award and extends for a period of One (1) year(s).

**Renewal Term:** This Contract may be renewed upon the mutual written consent of the Agency, and the Vendor, with approval of the Purchasing Division and the Attorney General's office (Attorney General approval is as to form only). Any request for renewal should be delivered to the Agency and then submitted to the Purchasing Division thirty (30) days prior to the expiration date of the initial contract term or appropriate renewal term. A Contract renewal shall be in accordance with the terms and conditions of the original contract. Unless otherwise specified below, renewal of this Contract is limited to Three (3) successive one (1) year periods or multiple renewal periods of less than one year, provided that the multiple renewal periods do not exceed the total number of months available in all renewal years combined. Automatic renewal of this Contract is prohibited. Renewals must be approved by the Vendor, Agency, Purchasing Division and Attorney General's office (Attorney General approval is as to form only)

**Alternate Renewal Term** – This contract may be renewed for \_\_\_\_\_ successive \_\_\_\_\_ year periods or shorter periods provided that they do not exceed the total number of months contained in all available renewals. Automatic renewal of this Contract is prohibited. Renewals must be approved by the Vendor, Agency, Purchasing Division and Attorney General's office (Attorney General approval is as to form only)

**Delivery Order Limitations:** In the event that this contract permits delivery orders, a delivery order may only be issued during the time this Contract is in effect. Any delivery order issued within one year of the expiration of this Contract shall be effective for one year from the date the delivery order is issued. No delivery order may be extended beyond one year after this Contract has expired.

**Fixed Period Contract:** This Contract becomes effective upon Vendor's receipt of the notice to proceed and must be completed within \_\_\_\_\_ days.

**Fixed Period Contract with Renewals:** This Contract becomes effective upon Vendor's receipt of the notice to proceed and part of the Contract more fully described in the attached specifications must be completed within \_\_\_\_\_ days. Upon completion of the work covered by the preceding sentence, the vendor agrees that maintenance, monitoring, or warranty services will be provided for \_\_\_\_\_ year(s) thereafter.

**One Time Purchase:** The term of this Contract shall run from the issuance of the Award Document until all of the goods contracted for have been delivered, but in no event will this Contract extend for more than one fiscal year.

**Other:** See attached.

**4. NOTICE TO PROCEED:** Vendor shall begin performance of this Contract immediately upon receiving notice to proceed unless otherwise instructed by the Agency. Unless otherwise specified, the fully executed Award Document will be considered notice to proceed.

**5. QUANTITIES:** The quantities required under this Contract shall be determined in accordance with the category that has been identified as applicable to this Contract below.

**Open End Contract:** Quantities listed in this Solicitation are approximations only, based on estimates supplied by the Agency. It is understood and agreed that the Contract shall cover the quantities actually ordered for delivery during the term of the Contract, whether more or less than the quantities shown.

**Service:** The scope of the service to be provided will be more clearly defined in the specifications included herewith.

**Combined Service and Goods:** The scope of the service and deliverable goods to be provided will be more clearly defined in the specifications included herewith.

**One Time Purchase:** This Contract is for the purchase of a set quantity of goods that are identified in the specifications included herewith. Once those items have been delivered, no additional goods may be procured under this Contract without an appropriate change order approved by the Vendor, Agency, Purchasing Division, and Attorney General's office.

**6. EMERGENCY PURCHASES:** The Purchasing Division Director may authorize the Agency to purchase goods or services in the open market that Vendor would otherwise provide under this Contract if those goods or services are for immediate or expedited delivery in an emergency. Emergencies shall include, but are not limited to, delays in transportation or an unanticipated increase in the volume of work. An emergency purchase in the open market, approved by the Purchasing Division Director, shall not constitute a breach of this Contract and shall not entitle the Vendor to any form of compensation or damages. This provision does not excuse the State from fulfilling its obligations under a One Time Purchase contract.

**7. REQUIRED DOCUMENTS:** All of the items checked below must be provided to the Purchasing Division by the Vendor as specified below.

**BID BOND (Construction Only):** Pursuant to the requirements contained in W. Va. Code § 5-22-1(c), All Vendors submitting a bid on a construction project shall furnish a valid bid bond in the amount of five percent (5%) of the total amount of the bid protecting the State of West Virginia. The bid bond must be submitted with the bid.

**PERFORMANCE BOND:** The apparent successful Vendor shall provide a performance bond in the amount of 100% of the contract. The performance bond must be received by the Purchasing Division prior to Contract award.

**LABOR/MATERIAL PAYMENT BOND:** The apparent successful Vendor shall provide a labor/material payment bond in the amount of 100% of the Contract value. The labor/material payment bond must be delivered to the Purchasing Division prior to Contract award.

In lieu of the Bid Bond, Performance Bond, and Labor/Material Payment Bond, the Vendor may provide certified checks, cashier's checks, or irrevocable letters of credit. Any certified check, cashier's check, or irrevocable letter of credit provided in lieu of a bond must be of the same amount and delivered on the same schedule as the bond it replaces. A letter of credit submitted in lieu of a performance and labor/material payment bond will only be allowed for projects under \$100,000. Personal or business checks are not acceptable. Notwithstanding the foregoing, West Virginia Code § 5-22-1 (d) mandates that a vendor provide a performance and labor/material payment bond for construction projects. Accordingly, substitutions for the performance and labor/material payment bonds for construction projects is not permitted.

**MAINTENANCE BOND:** The apparent successful Vendor shall provide a two (2) year maintenance bond covering the roofing system. The maintenance bond must be issued and delivered to the Purchasing Division prior to Contract award.

**LICENSE(S) / CERTIFICATIONS / PERMITS:** In addition to anything required under the Section of the General Terms and Conditions entitled Licensing, the apparent successful Vendor shall furnish proof of the following licenses, certifications, and/or permits prior to Contract award, in a form acceptable to the Purchasing Division.

The apparent successful Vendor shall also furnish proof of any additional licenses or certifications contained in the specifications prior to Contract award regardless of whether or not that requirement is listed above.



**8. INSURANCE:** The apparent successful Vendor shall furnish proof of the insurance identified by a checkmark below and must include the State as an additional insured on each policy prior to Contract award. The insurance coverages identified below must be maintained throughout the life of this contract. Thirty (30) days prior to the expiration of the insurance policies, Vendor shall provide the Agency with proof that the insurance mandated herein has been continued. Vendor must also provide Agency with immediate notice of any changes in its insurance policies, including but not limited to, policy cancelation, policy reduction, or change in insurers. The apparent successful Vendor shall also furnish proof of any additional insurance requirements contained in the specifications prior to Contract award regardless of whether or not that insurance requirement is listed in this section.

Vendor must maintain:

- Commercial General Liability Insurance** in at least an amount of: \$1,000,000-See Below per occurrence.
- Automobile Liability Insurance** in at least an amount of: \$1,000,000-See Below per occurrence.
- Professional/Malpractice/Errors and Omission Insurance** in at least an amount of: \_\_\_\_\_ per occurrence.
- Commercial Crime and Third Party Fidelity Insurance** in an amount of: \_\_\_\_\_ per occurrence.
- Cyber Liability Insurance** in an amount of: \_\_\_\_\_ per occurrence.
- Builders Risk Insurance** in an amount equal to 100% of the amount of the Contract.
- Pollution Insurance** in an amount of: \_\_\_\_\_ per occurrence.
- Aircraft Liability** in an amount of: \_\_\_\_\_ per occurrence.
- \*\*Please make insurance certificate holder to read as follows:**  
State of WV, 1900 Kanawha Blvd E, Bldg 5, Charleston, WV 25305
- \*\*State of WV must be listed as additional insured.**
- 
-

Notwithstanding anything contained in this section to the contrary, the Director of the Purchasing Division reserves the right to waive the requirement that the State be named as an additional insured on one or more of the Vendor's insurance policies if the Director finds that doing so is in the State's best interest.

**9. WORKERS' COMPENSATION INSURANCE:** The apparent successful Vendor shall comply with laws relating to workers compensation, shall maintain workers' compensation insurance when required, and shall furnish proof of workers' compensation insurance upon request.

**10. [Reserved]**

**11. LIQUIDATED DAMAGES:** This clause shall in no way be considered exclusive and shall not limit the State or Agency's right to pursue any other available remedy. Vendor shall pay liquidated damages in the amount specified below or as described in the specifications:

\_\_\_\_\_ for \_\_\_\_\_

Liquidated Damages Contained in the Specifications

**12. ACCEPTANCE:** Vendor's signature on its bid, or on the certification and signature page, constitutes an offer to the State that cannot be unilaterally withdrawn, signifies that the product or service proposed by vendor meets the mandatory requirements contained in the Solicitation for that product or service, unless otherwise indicated, and signifies acceptance of the terms and conditions contained in the Solicitation unless otherwise indicated.

**13. PRICING:** The pricing set forth herein is firm for the life of the Contract, unless specified elsewhere within this Solicitation/Contract by the State. A Vendor's inclusion of price adjustment provisions in its bid, without an express authorization from the State in the Solicitation to do so, may result in bid disqualification. Notwithstanding the foregoing, Vendor must extend any publicly advertised sale price to the State and invoice at the lower of the contract price or the publicly advertised sale price.

**14. PAYMENT IN ARREARS:** Payment in advance is prohibited under this Contract. Payment may only be made after the delivery and acceptance of goods or services. The Vendor shall submit invoices, in arrears.

**15. PAYMENT METHODS:** Vendor must accept payment by electronic funds transfer and P-Card. (The State of West Virginia's Purchasing Card program, administered under contract by a banking institution, processes payment for goods and services through state designated credit cards.)

**16. TAXES:** The Vendor shall pay any applicable sales, use, personal property or any other taxes arising out of this Contract and the transactions contemplated thereby. The State of West Virginia is exempt from federal and state taxes and will not pay or reimburse such taxes.

**17. ADDITIONAL FEES:** Vendor is not permitted to charge additional fees or assess additional charges that were not either expressly provided for in the solicitation published by the State of West Virginia or included in the unit price or lump sum bid amount that Vendor is required by the solicitation to provide. Including such fees or charges as notes to the solicitation may result in rejection of vendor's bid. Requesting such fees or charges be paid after the contract has been awarded may result in cancellation of the contract.

**18. FUNDING:** This Contract shall continue for the term stated herein, contingent upon funds being appropriated by the Legislature or otherwise being made available. In the event funds are not appropriated or otherwise made available, this Contract becomes void and of no effect beginning on July 1 of the fiscal year for which funding has not been appropriated or otherwise made available.

**19. CANCELLATION:** The Purchasing Division Director reserves the right to cancel this Contract immediately upon written notice to the vendor if the materials or workmanship supplied do not conform to the specifications contained in the Contract. The Purchasing Division Director may also cancel any purchase or Contract upon 30 days written notice to the Vendor in accordance with West Virginia Code of State Rules § 148-1-5.2.b.

**20. TIME:** Time is of the essence with regard to all matters of time and performance in this Contract.

**21. APPLICABLE LAW:** This Contract is governed by and interpreted under West Virginia law without giving effect to its choice of law principles. Any information provided in specification manuals, or any other source, verbal or written, which contradicts or violates the West Virginia Constitution, West Virginia Code or West Virginia Code of State Rules is void and of no effect.

**22. COMPLIANCE WITH LAWS:** Vendor shall comply with all applicable federal, state, and local laws, regulations and ordinances. By submitting a bid, Vendor acknowledges that it has reviewed, understands, and will comply with all applicable laws, regulations, and ordinances.

**SUBCONTRACTOR COMPLIANCE:** Vendor shall notify all subcontractors providing commodities or services related to this Contract that as subcontractors, they too are required to comply with all applicable laws, regulations, and ordinances. Notification under this provision must occur prior to the performance of any work under the contract by the subcontractor.

**23. ARBITRATION:** Any references made to arbitration contained in this Contract, Vendor's bid, or in any American Institute of Architects documents pertaining to this Contract are hereby deleted, void, and of no effect.

**24. MODIFICATIONS:** This writing is the parties' final expression of intent. Notwithstanding anything contained in this Contract to the contrary no modification of this Contract shall be binding without mutual written consent of the Agency, and the Vendor, with approval of the Purchasing Division and the Attorney General's office (Attorney General approval is as to form only). Any change to existing contracts that adds work or changes contract cost, and were not included in the original contract, must be approved by the Purchasing Division and the Attorney General's Office (as to form) prior to the implementation of the change or commencement of work affected by the change.

**25. WAIVER:** The failure of either party to insist upon a strict performance of any of the terms or provision of this Contract, or to exercise any option, right, or remedy herein contained, shall not be construed as a waiver or a relinquishment for the future of such term, provision, option, right, or remedy, but the same shall continue in full force and effect. Any waiver must be expressly stated in writing and signed by the waiving party.

**26. SUBSEQUENT FORMS:** The terms and conditions contained in this Contract shall supersede any and all subsequent terms and conditions which may appear on any form documents submitted by Vendor to the Agency or Purchasing Division such as price lists, order forms, invoices, sales agreements, or maintenance agreements, and includes internet websites or other electronic documents. Acceptance or use of Vendor's forms does not constitute acceptance of the terms and conditions contained thereon.

**27. ASSIGNMENT:** Neither this Contract nor any monies due, or to become due hereunder, may be assigned by the Vendor without the express written consent of the Agency, the Purchasing Division, the Attorney General's office (as to form only), and any other government agency or office that may be required to approve such assignments.

**28. WARRANTY:** The Vendor expressly warrants that the goods and/or services covered by this Contract will: (a) conform to the specifications, drawings, samples, or other description furnished or specified by the Agency; (b) be merchantable and fit for the purpose intended; and (c) be free from defect in material and workmanship.

**29. STATE EMPLOYEES:** State employees are not permitted to utilize this Contract for personal use and the Vendor is prohibited from permitting or facilitating the same.

**30. PRIVACY, SECURITY, AND CONFIDENTIALITY:** The Vendor agrees that it will not disclose to anyone, directly or indirectly, any such personally identifiable information or other confidential information gained from the Agency, unless the individual who is the subject of the information consents to the disclosure in writing or the disclosure is made pursuant to the Agency's policies, procedures, and rules. Vendor further agrees to comply with the Confidentiality Policies and Information Security Accountability Requirements, set forth in <http://www.state.wv.us/admin/purchase/privacy/default.html>.

**31. YOUR SUBMISSION IS A PUBLIC DOCUMENT:** Vendor's entire response to the Solicitation and the resulting Contract are public documents. As public documents, they will be disclosed to the public following the bid/proposal opening or award of the contract, as required by the competitive bidding laws of West Virginia Code §§ 5A-3-1 et seq., 5-22-1 et seq., and 5G-1-1 et seq. and the Freedom of Information Act West Virginia Code §§ 29B-1-1 et seq.

**DO NOT SUBMIT MATERIAL YOU CONSIDER TO BE CONFIDENTIAL, A TRADE SECRET, OR OTHERWISE NOT SUBJECT TO PUBLIC DISCLOSURE.**

Submission of any bid, proposal, or other document to the Purchasing Division constitutes your explicit consent to the subsequent public disclosure of the bid, proposal, or document. The Purchasing Division will disclose any document labeled "confidential," "proprietary," "trade secret," "private," or labeled with any other claim against public disclosure of the documents, to include any "trade secrets" as defined by West Virginia Code § 47-22-1 et seq. All submissions are subject to public disclosure without notice.

**32. LICENSING:** In accordance with West Virginia Code of State Rules § 148-1-6.1.e, Vendor must be licensed and in good standing in accordance with any and all state and local laws and requirements by any state or local agency of West Virginia, including, but not limited to, the West Virginia Secretary of State's Office, the West Virginia Tax Department, West Virginia Insurance Commission, or any other state agency or political subdivision. Obligations related to political subdivisions may include, but are not limited to, business licensing, business and occupation taxes, inspection compliance, permitting, etc. Upon request, the Vendor must provide all necessary releases to obtain information to enable the Purchasing Division Director or the Agency to verify that the Vendor is licensed and in good standing with the above entities.

**SUBCONTRACTOR COMPLIANCE:** Vendor shall notify all subcontractors providing commodities or services related to this Contract that as subcontractors, they too are required to be licensed, in good standing, and up-to-date on all state and local obligations as described in this section. Obligations related to political subdivisions may include, but are not limited to, business licensing, business and occupation taxes, inspection compliance, permitting, etc. Notification under this provision must occur prior to the performance of any work under the contract by the subcontractor.

**33. ANTITRUST:** In submitting a bid to, signing a contract with, or accepting a Award Document from any agency of the State of West Virginia, the Vendor agrees to convey, sell, assign, or transfer to the State of West Virginia all rights, title, and interest in and to all causes of action it may now or hereafter acquire under the antitrust laws of the United States and the State of West Virginia for price fixing and/or unreasonable restraints of trade relating to the particular commodities or services purchased or acquired by the State of West Virginia. Such assignment shall be made and become effective at the time the purchasing agency tenders the initial payment to Vendor.

**34. VENDOR CERTIFICATIONS:** By signing its bid or entering into this Contract, Vendor certifies (1) that its bid or offer was made without prior understanding, agreement, or connection with any corporation, firm, limited liability company, partnership, person or entity submitting a bid or offer for the same material, supplies, equipment or services; (2) that its bid or offer is in all respects fair and without collusion or fraud; (3) that this Contract is accepted or entered into without any prior understanding, agreement, or connection to any other entity that could be considered a violation of law; and (4) that it has reviewed this Solicitation in its entirety; understands the requirements, terms and conditions, and other information contained herein.

Vendor's signature on its bid or offer also affirms that neither it nor its representatives have any interest, nor shall acquire any interest, direct or indirect, which would compromise the performance of its services hereunder. Any such interests shall be promptly presented in detail to the Agency. The individual signing this bid or offer on behalf of Vendor certifies that he or she is authorized by the Vendor to execute this bid or offer or any documents related thereto on Vendor's behalf; that he or she is authorized to bind the Vendor in a contractual relationship; and that, to the best of his or her knowledge, the Vendor has properly registered with any State agency that may require registration.

**35. VENDOR RELATIONSHIP:** The relationship of the Vendor to the State shall be that of an independent contractor and no principal-agent relationship or employer-employee relationship is contemplated or created by this Contract. The Vendor as an independent contractor is solely liable for the acts and omissions of its employees and agents. Vendor shall be responsible for selecting, supervising, and compensating any and all individuals employed pursuant to the terms of this Solicitation and resulting contract. Neither the Vendor, nor any employees or subcontractors of the Vendor, shall be deemed to be employees of the State for any purpose whatsoever. Vendor shall be exclusively responsible for payment of employees and contractors for all wages and salaries, taxes, withholding payments, penalties, fees, fringe benefits, professional liability insurance premiums, contributions to insurance and pension, or other deferred compensation plans, including but not limited to, Workers' Compensation and Social Security obligations, licensing fees, etc. and the filing of all necessary documents, forms, and returns pertinent to all of the foregoing.

Vendor shall hold harmless the State, and shall provide the State and Agency with a defense against any and all claims including, but not limited to, the foregoing payments, withholdings, contributions, taxes, Social Security taxes, and employer income tax returns.

**36. INDEMNIFICATION:** The Vendor agrees to indemnify, defend, and hold harmless the State and the Agency, their officers, and employees from and against: (1) Any claims or losses for services rendered by any subcontractor, person, or firm performing or supplying services, materials, or supplies in connection with the performance of the Contract; (2) Any claims or losses resulting to any person or entity injured or damaged by the Vendor, its officers, employees, or subcontractors by the publication, translation, reproduction, delivery, performance, use, or disposition of any data used under the Contract in a manner not authorized by the Contract, or by Federal or State statutes or regulations; and (3) Any failure of the Vendor, its officers, employees, or subcontractors to observe State and Federal laws including, but not limited to, labor and wage and hour laws.

**37. PURCHASING AFFIDAVIT:** In accordance with West Virginia Code §§ 5A-3-10a and 5-22-1(i), the State is prohibited from awarding a contract to any bidder that owes a debt to the State or a political subdivision of the State, Vendors are required to sign, notarize, and submit the Purchasing Affidavit to the Purchasing Division affirming under oath that it is not in default on any monetary obligation owed to the state or a political subdivision of the state.

**38. ADDITIONAL AGENCY AND LOCAL GOVERNMENT USE:** This Contract may be utilized by other agencies, spending units, and political subdivisions of the State of West Virginia; county, municipal, and other local government bodies; and school districts ("Other Government Entities"), provided that both the Other Government Entity and the Vendor agree. Any extension of this Contract to the aforementioned Other Government Entities must be on the same prices, terms, and conditions as those offered and agreed to in this Contract, provided that such extension is in compliance with the applicable laws, rules, and ordinances of the Other Government Entity. A refusal to extend this Contract to the Other Government Entities shall not impact or influence the award of this Contract in any manner.

**39. CONFLICT OF INTEREST:** Vendor, its officers or members or employees, shall not presently have or acquire an interest, direct or indirect, which would conflict with or compromise the performance of its obligations hereunder. Vendor shall periodically inquire of its officers, members and employees to ensure that a conflict of interest does not arise. Any conflict of interest discovered shall be promptly presented in detail to the Agency.

**40. REPORTS:** Vendor shall provide the Agency and/or the Purchasing Division with the following reports identified by a checked box below:

Such reports as the Agency and/or the Purchasing Division may request. Requested reports may include, but are not limited to, quantities purchased, agencies utilizing the contract, total contract expenditures by agency, etc.

Quarterly reports detailing the total quantity of purchases in units and dollars, along with a listing of purchases by agency. Quarterly reports should be delivered to the Purchasing Division via email at [purchasing.requisitions@wv.gov](mailto:purchasing.requisitions@wv.gov).

**41. BACKGROUND CHECK:** In accordance with W. Va. Code § 15-2D-3, the Director of the Division of Protective Services shall require any service provider whose employees are regularly employed on the grounds or in the buildings of the Capitol complex or who have access to sensitive or critical information to submit to a fingerprint-based state and federal background inquiry through the state repository. The service provider is responsible for any costs associated with the fingerprint-based state and federal background inquiry.

After the contract for such services has been approved, but before any such employees are permitted to be on the grounds or in the buildings of the Capitol complex or have access to sensitive or critical information, the service provider shall submit a list of all persons who will be physically present and working at the Capitol complex to the Director of the Division of Protective Services for purposes of verifying compliance with this provision. The State reserves the right to prohibit a service provider's employees from accessing sensitive or critical information or to be present at the Capitol complex based upon results addressed from a criminal background check.

Revised 06/05/2019

Service providers should contact the West Virginia Division of Protective Services by phone at (304) 558-9911 for more information.

**42. PREFERENCE FOR USE OF DOMESTIC STEEL PRODUCTS:** Except when authorized by the Director of the Purchasing Division pursuant to W. Va. Code § 5A-3-56, no contractor may use or supply steel products for a State Contract Project other than those steel products made in the United States. A contractor who uses steel products in violation of this section may be subject to civil penalties pursuant to W. Va. Code § 5A-3-56. As used in this section:

- a. "State Contract Project" means any erection or construction of, or any addition to, alteration of or other improvement to any building or structure, including, but not limited to, roads or highways, or the installation of any heating or cooling or ventilating plants or other equipment, or the supply of and materials for such projects, pursuant to a contract with the State of West Virginia for which bids were solicited on or after June 6, 2001.
- b. "Steel Products" means products rolled, formed, shaped, drawn, extruded, forged, cast, fabricated or otherwise similarly processed, or processed by a combination of two or more or such operations, from steel made by the open heath, basic oxygen, electric furnace, Bessemer or other steel making process. The Purchasing Division Director may, in writing, authorize the use of foreign steel products if:
- c. The cost for each contract item used does not exceed one tenth of one percent (.1%) of the total contract cost or two thousand five hundred dollars (\$2,500.00), whichever is greater. For the purposes of this section, the cost is the value of the steel product as delivered to the project; or
- d. The Director of the Purchasing Division determines that specified steel materials are not produced in the United States in sufficient quantity or otherwise are not reasonably available to meet contract requirements.

**43. PREFERENCE FOR USE OF DOMESTIC ALUMINUM, GLASS, AND STEEL:** In Accordance with W. Va. Code § 5-19-1 et seq., and W. Va. CSR § 148-10-1 et seq., for every contract or subcontract, subject to the limitations contained herein, for the construction, reconstruction, alteration, repair, improvement or maintenance of public works or for the purchase of any item of machinery or equipment to be used at sites of public works, only domestic aluminum, glass or steel products shall be supplied unless the spending officer determines, in writing, after the receipt of offers or bids, (1) that the cost of domestic aluminum, glass or steel products is unreasonable or inconsistent with the public interest of the State of West Virginia, (2) that domestic aluminum, glass or steel products are not produced in sufficient quantities to meet the contract requirements, or (3) the available domestic aluminum, glass, or steel do not meet the contract specifications. This provision only applies to public works contracts awarded in an amount more than fifty thousand dollars (\$50,000) or public works contracts that require more than ten thousand pounds of steel products.

The cost of domestic aluminum, glass, or steel products may be unreasonable if the cost is more than twenty percent (20%) of the bid or offered price for foreign made aluminum, glass, or steel products. If the domestic aluminum, glass or steel products to be supplied or produced in a



“substantial labor surplus area”, as defined by the United States Department of Labor, the cost of domestic aluminum, glass, or steel products may be unreasonable if the cost is more than thirty percent (30%) of the bid or offered price for foreign made aluminum, glass, or steel products. This preference shall be applied to an item of machinery or equipment, as indicated above, when the item is a single unit of equipment or machinery manufactured primarily of aluminum, glass or steel, is part of a public works contract and has the sole purpose or of being a permanent part of a single public works project. This provision does not apply to equipment or machinery purchased by a spending unit for use by that spending unit and not as part of a single public works project.

All bids and offers including domestic aluminum, glass or steel products that exceed bid or offer prices including foreign aluminum, glass or steel products after application of the preferences provided in this provision may be reduced to a price equal to or lower than the lowest bid or offer price for foreign aluminum, glass or steel products plus the applicable preference. If the reduced bid or offer prices are made in writing and supersede the prior bid or offer prices, all bids or offers, including the reduced bid or offer prices, will be reevaluated in accordance with this rule.

**44. INTERESTED PARTY SUPPLEMENTAL DISCLOSURE:** W. Va. Code § 6D-1-2 requires that for contracts with an actual or estimated value of at least \$1 million, the vendor must submit to the Agency a supplemental disclosure of interested parties reflecting any new or differing interested parties to the contract, which were not included in the original pre-award interested party disclosure, within 30 days following the completion or termination of the contract. A copy of that form is included with this solicitation or can be obtained from the WV Ethics Commission. This requirement does not apply to publicly traded companies listed on a national or international stock exchange. A more detailed definition of interested parties can be obtained from the form referenced above.

**REQUEST FOR QUOTATION**  
**CRFQ DOT2000000028**  
**(WVDOH CLASS 503) Extendable width Wheeled Asphalt Paver**  
**ROADTEC RP170e or Equal (7020EC02)**

---

**SPECIFICATIONS**

1. **PURPOSE AND SCOPE:** The West Virginia Purchasing Division is soliciting bids On behalf of the West Virginia Division of Highways, Department of Transportation to establish an open-end contract for an Roadtec RP170e or equal Asphalt Paver 8-foot to 15-foot Extendible Width
  
2. **DEFINITIONS:** The terms listed below shall have the meanings assigned to them below. Additional definitions can be found in section 2 of the General Terms and Conditions.
  - 2.1 **“Contract Item”** or **“Contract Items”** means the list of items identified in Section 3, Subsection 1 below.
  - 2.2 **“Pricing Pages”** means the schedule of prices, estimated order quantity, and totals contained in wvOASIS or attached hereto as Exhibit A and used to evaluate the Solicitation responses.
  - 2.3 **“Solicitation”** means the official notice of an opportunity to supply the State with goods or services that is published by the Purchasing Division.
  - 2.4 **“WVDOH”** means West Virginia Division of Highways.
  - 2.5 **“OSHA”** means Occupational Safety and Health Act of 1970/ Exhibit C, Reference [www.osha.gov](http://www.osha.gov).
  - 2.6 **“LED”** means light emitting diode.
  
3. **GENERAL REQUIREMENTS:**
  - 3.1 **Contract Items and Mandatory Requirements:** Vendor shall provide Agency with the Contract Items listed below on an open-end and continuing basis. Contract Items must meet or exceed the mandatory requirements as shown below.
    - 3.1.1 **Asphalt Paver Tractor 8-foot to 15-foot Extendible Width Paver Roadtec RP 170e or equal**
      - 3.1.1.1 The unit specified herein and offered shall be manufactured after January 1, 2020 and must be a new unit, not previously used or sold.
      - 3.1.1.2 The Asphalt Paver Tractor shall be a current model under standard production by the manufacturer, with not less than one year of production and field use.

**REQUEST FOR QUOTATION**  
**CRFQ DOT2000000028**  
**(WVDOH CLASS 503) Extendable width Wheeled Asphalt Paver**  
**ROADTEC RP170e or Equal (7020EC02)**

---

**3.1.2 Paver Tractor Dimensions, Weights and Capacities.**

**3.1.2.1** Length with front mounted hydraulic extendible screed 21-foot 10-inches minimum.

**3.1.2.2** Width 8-foot 6-inches maximum transport width.

**3.1.2.3** Paver transporting height 10.5- foot maximum.

**3.1.2.4** Paver with front mounted hydraulic extendible Screed Weight 35,800lbs. maximum.

**3.1.2.5** Fuel tank capacity 80-gallons minimum.

**3.1.2.6** DEF tank capacity 5-gallons minimum.

**3.1.2.7** Hydraulic Tank 65 gallons minimum.

**3.1.3 Paver Tractor, Wheel Suspension and Traction Drive**

**3.1.3.1** Drive tires (2) shall be a minimum of 16:00 x 24 (40.6 m x 610 mm) high flotation sand rib tires and shall be hydroflated for maximum tractive effort.

**3.1.3.2** Front steering suspension shall consist of four solid bogie wheels of minimum 14-inches x 22-foot dimension, arranged in pairs, and each side tied together with a solid linkage to prevent misalignment or bowing from one side to the other. Paver to have maximum inside turning radius of 32-inches.

**3.1.3.3** Traction drive to rear tires shall be hydrostatic. Paving speeds shall be infinitely variable to at least 300 fpm and travel speeds infinitely variable to at least 10 mph. Two speed planetary drives shall be shift able at either operator's station via an electric switch.

**3.1.3.4** Paver shall have differential lock located at each operator's station to provide momentary lock of both drive motors to prevent drive wheel slippage.

**3.1.3.5** Paver must have Front Wheel assist both rear bogie wheels shall be hydraulic motor drives.

**REQUEST FOR QUOTATION**  
**CRFQ DOT2000000028**  
**(WVDOH CLASS 503) Extendable width Wheeled Asphalt Paver**  
**ROADTEC RP170e or Equal (7020EC02)**

---

**3.1.4 Paver Tractor Engine**

- 3.1.4.1 Engine shall be turbocharged; water-cooled (6) six-cylinder diesel
- 3.1.4.2 Engine shall be 174 hp minimum at 2200 rpm Tier 4 Final emissions compliant.
- 3.1.4.3 Engine shall be 12 or 24-volt electric starting, minimum 100-amp alternator, with battery disconnect switch.
- 3.1.4.4 Engine shall have full digital engine condition instrumentation, oil and fuel filters, engine high temperature/low oil pressure shutdown, muffler and severe duty air cleaner.
- 3.1.4.5 Engine turbocharger shall include an insulated turbo blanket to minimize heat in the engine compartment.
- 3.1.4.6 Engine must be easily accessible through a one-piece hydraulically raise/lower hood with manual override and safety lock.

**3.1.5 Paver Tractor Brakes**

- 3.1.5.1 Paver shall be equipped with spring-applied braking system, brake systems, which must comply with SAE J 2118
- 3.1.5.2 Paver brake systems must always automatically apply when pressure is not relieved by control of the operator. System control must include a switch from each operator's station as well as foot-pedal for control during operation.

**3.1.6 Paver Tractor Controls**

- 3.1.6.1 Paver shall be equipped with dual operator's consoles.
- 3.1.6.2 Paver Consoles must hydraulically move beyond the side of the paver for visibility in infinitely adjustable positions.
- 3.1.6.3 Paver Stations must consist of starting functions, two deluxe swivel padded seats with armrest, adjustable backrest and a single transferable umbrella.

**REQUEST FOR QUOTATION**  
**CRFQ DOT2000000028**  
**(WVDOH CLASS 503) Extendable width Wheeled Asphalt Paver**  
**ROADTEC RP170e or Equal (7020EC02)**

---

**3.1.6.4** Each operator's console shall include power hydraulic steering with tilt steering wheel.

**3.1.6.5** Paver propel console and function console shall be mounted to either side of the operator's seat. Both propel consoles shall include a rotary speed selector, electric forward/reverse control with locking center neutral position; parking brake and emergency stop control.

**3.1.6.6** Both paver control consoles shall be furnished with toggle switch control for the following functions: hopper wings, screed lift, screed vibrators, auger and feed conveyor operation, auger raise/lower and paver start.

**3.1.6.7** Pavers operators control station must include a device for digital display of engine parameters including but not limited to engine / hydraulic condition gauges, tachometer and hour meter.

**3.1.7 Paver Tractor Mainframe**

**3.1.7.1** Paver mainframe will be constructed of one-piece ½-inch side sheets with solid 2-inch thick minimum front cross-member .

**3.1.7.2** Axle connecting front steering bogie assemblies shall be a minimum 4-inch diameter solid shaft extending through entire width of paver and frame.

**3.1.8 Paver Tractor Hopper**

**3.1.8.1** The hopper shall have a capacity of 11 tons minimum of material with hydraulic powered folding hopper wings controlled at either operators' stations.

**3.1.8.2** The front of the hopper shall be a minimum of 10-foot wide to permit easy alignment of truck dump box.

**3.1.8.3** Two separate power adjustable flow gates, at the rear of the hopper, shall be provided to aid in flow of material to the center of the screed.

**REQUEST FOR QUOTATION**  
**CRFQ DOT2000000028**  
**(WVDOH CLASS 503) Extendable width Wheeled Asphalt Paver**  
**ROADTEC RP170e or Equal (7020EC02)**

---

**3.1.8.4** Oscillating push rollers mounted to the front of the paver frame shall also be included to aid in dump truck alignment.

**3.1.9 Paver Tractor Feed Conveyor System**

**3.1.9.1** Paver shall have Independent left and right feed conveyors with variable speed control through independent hydrostatic drives.

**3.1.9.2** Each paver feed conveyor will consist of solid drag bars mounted to roller bushed drag slat chains riding over solid, replaceable wear floors consisting of minimum 3/8-inch abrasion resistant plates of minimum 400 Brinell hardness.

**3.1.9.3** Paver conveyor chain covers shall be bolted on to allow easy removal to access conveyor chains. Both head shaft and foot shaft grease fittings shall be location outside the paver frame for easy daily maintenance.

**3.1.10 Paver Tractor Auger Conveyor System**

**3.1.10.1** Paver Auger assembly will have the ability to raise/lower/tilt each side independent of the other via hydraulic cylinders controlled by toggle switches at both paver and screed operators' stations.

**3.1.10.2** Augers shall be driven independent of the feed conveyors by separate hydraulic motors with variable speed control provided by sonic (non-contacting) proportional sensors located at each end of the vibrating screed.

**3.1.10.3** Augers and feeders shall be hydraulically interlocked to provide uniform material flow to the screed as dictated by the proportional feed sensors.

**3.1.10.4** Manufacturer shall provide a means to stop the feed conveyors and operate the augers independent of feeders (feeder override) by way of toggle switches at each screed operator's console. Augers shall consist of minimum 16" diameter full cast Ni-hard or equivalent hardness material.

**3.1.10.5** Augers shall be reversing distribution Augers.

**REQUEST FOR QUOTATION**  
**CRFQ DOT2000000028**  
**(WVDOH CLASS 503) Extendable width Wheeled Asphalt Paver**  
**ROADTEC RP170e or Equal (7020EC02)**

---

**3.1.11 Paver Tractor Fume Extraction System**

**3.1.11.1** Paver shall meet the July 1, 1997 requirements for factory standard fume scavenge systems on all highway class asphalt pavers. The scavenge or extraction system will meet all testing criteria and fume recovery efficiencies as mandated by NIOSH guidelines.

**3.1.12 Paver Screed (Carlson EZ IV8 brand or equal)**

**3.1.12.1** Screed shall be a minimum of 8-foot wide hydraulically extendable vibratory compacting and shall be of the free-floating type.

**3.1.12.2** Screed shall have a minimum 34-kilowatt hydraulic driven generator that provides power to electrically heat the screed.

**3.1.12.3** Screed generator must be of enough size to heat the entire screed and run a 4-kilowatt load of paver lighting concurrently.

**3.1.12.4** Screed shall have hydraulic extension with electric heat and vibration that are mounted to the front of the main screed. These extensions shall be slop- able and have height match functionality with electric over hydraulic controls.

**3.1.12.5** The main section of the screed shall have a minimum plate width, front to back, of 2-inches, a minimum screed plate thickness of ½ -inch, a minimum 400 BHN plate hardness, capable of laying materials from ½-inch minimum to 12-inch maximum in depth. The extension screed sections shall have a minimum plate width, front to back, of 8-inch , a minimum screed plate thickness of -inch , a minimum 400 BHN plate hardness.

**3.1.12.6** Screed shall include dual screed control boxes with toggle switch control on the main screed.

**3.1.12.7** Screed shall have dual remote screed control boxes for off screed adjustments with lockable vandal covers for control boxes, power remote screed control crown control and spring-loaded two-piece end gates.

**3.1.12.8** Paver tractor shall have a screed boost package with adjustable lifting pressures and time limits.

**REQUEST FOR QUOTATION**  
**CRFQ DOT2000000028**  
**(WVDOH CLASS 503) Extendable width Wheeled Asphalt Paver**  
**ROADTEC RP170e or Equal (7020EC02)**

---

**3.1.13 Paver Tractor/ Screed Accessories and Lighting**

**3.1.13.1** Shall have spray washdown system 12-gallon minimum capacity w/retractable hose 25-foot minimum.

**3.1.13.2** Shall have Standard LED lighting package for manufacturer bid.

**3.1.13.3** Shall include (1) operators' umbrella.

**3.1.13.4** Paver shall have Guardian Telematics or equal for monitoring and troubleshooting of machine with full machine data remotely with no subscription fee for first two-years of operation.

**3.1.13.5** Machine shall have Dump signal light.

**3.1.13.6** Machine shall have Lincoln Automated Lubrication system or equal.

**3.1.13.7** Paver shall be set up to accept sonic grade and slope control system if added.

**3.1.14 Unspecified Accessories & Features:** All parts, equipment, accessories, material, design and performance characteristics not specified herein, but which are necessary to provide a complete unit, must be furnished with each unit and required to conform to strength, quality of material, and quality of workmanship to those which are advertised and provided to the market in general by the unit industry. All parts and accessories advertised and regularly supplied as standard shall be included, except those which would represent duplication of these specified and except those which, by specification, are not to be furnished. All standard safety features, required by Federal and State Law, shall be included.

**3.1.15 Unit shall be delivered:** to WVDOH with all manufacturers recommended safety related decals and safety features intact.

**3.2 Miscellaneous Information:**

**3.2.1 Vendor Responsibility**

**3.2.1.1** The vendor is responsible to furnish an extendable width wheeled asphalt paver that is properly engineered and that conforms to all and any laws governing such equipment.



**REQUEST FOR QUOTATION**  
**CRFQ DOT2000000028**  
**(WVDOH CLASS 503) Extendable width Wheeled Asphalt Paver**  
**ROADTEC RP170e or Equal (7020EC02)**

---

**3.2.1.2** Inspection: WVDOH requires unit shall have a West Virginia State inspection sticker upon delivery, if applicable.

**3.2.2 Representative Unit for Test:**

**3.2.2.1** The successful vendor must (if specified) provide the DOH one (1) completed represented unit to be observed and evaluated on each order to ensure compliance with specification. If requested, the time period for testing and evaluation shall be seven (7) working days following receipt of the unit. DOH will incur no obligation for deterioration of surfaces, finishes, seals, and mechanical or electrical parts on the unit resulting from operation and testing within the limits of these specifications; nor will DOH incur obligation for damage to the unit resulting from failure to meet specifications when due care and attention is given by DOH and testing is done within the limits of these specifications. Failure of the pilot unit to satisfactorily meet specifications as bid may be cause for cancellation of the purchase order and return of the delivered unit along with all associated equipment to the vendor at the vendor's expense.

**3.2.3 Operating and Service Manuals and Parts Lists:**

**3.2.3.1** An operator's manual must be included with each unit upon delivery. A "line sheet" (if applicable) and the "Equipment Preventative Maintenance Questionnaire", (Exhibit "B") must be with pilot unit upon delivery, Attn: Marcia Lee. There must be 12 service/shop/maintenance manuals and 14 parts manuals; USB storage drive is preferred in lieu of parts manuals. Manuals and USB storage drive shall be delivered upon completion of delivery of total units. Failure to do so will delay payment.

**3.2.4 Training:**

**3.2.4.1** Manufacturers and/or dealers will be required to stage a thorough seminar on the subjects of Preventative Maintenance, Operator, and Mechanic Training. In order to keep operators and mechanics updated, the successful vendor shall conduct training sessions covering the operation, maintenance, trouble- shooting with each purchase order against this open-end contract.

Manufacturers and/or dealers shall be required to furnish the Training Academy with one (1) Operator's Manual to be shipped direct to

**REQUEST FOR QUOTATION**  
**CRFQ DOT2000000028**  
**(WVDOH CLASS 503) Extendable width Wheeled Asphalt Paver**  
**ROADTEC RP170e or Equal (7020EC02)**

---

**WVDOH**  
Training Academy  
P.O. Box 610  
Buckhannon, West Virginia 26201

Prior to delivery of the pilot unit. Training seminar to be held at the  
WVDOT, Equipment Division, Buckhannon, WV.

**3.2.5 Preventative Maintenance & Operator Procedures:**

**3.2.5.1** Manufacturers and/or dealers will be required to submit to the Equipment Division, in addition to the operating and service manuals, booklets and pamphlets explaining the Preventative Maintenance and Operator Procedures to be used by the operators of this equipment, and must include such things as daily prestart inspection procedure, service schedule, and routine maintenance required, safety precautions, etc. The successful vendor shall furnish all training aids; i.e. videos, projectors as required in conducting the training.

**3.2.6 Warranty and Service Policy:**

**3.2.6.1** Full 3-year 3000 hours on machine 100% Parts and Labor.

**3.2.6.2** Full 5-year 6000 Hours on Engine 100% Parts and

**4. CONTRACT AWARD:**

**4.1 Contract Award:** The Contract is intended to provide Agencies with a purchase price on all Contract Items. The Contract shall be awarded to Vendor that provides the Contract Items meeting the required specifications for the lowest overall total cost as shown on the Pricing Pages.

**4.2 Pricing Pages:** Vendor should complete the Pricing Pages (Exhibit A) by completing the Year, Make, Model, and inserting quoted unit price. Vendor must enter a Unit Price and multiply by the Estimated Quantity to calculate the Total Bid Amount. Vendor should complete the pricing pages in their entirety as failure to do so may result in Vendor's bids being disqualified.

The Pricing Page contains a list of the Contract Items and estimated purchase volume. The estimated purchase volume for each item represents the approximate volume of

**REQUEST FOR QUOTATION**  
**CRFQ DOT2000000028**  
**(WVDOH CLASS 503) Extendable width Wheeled Asphalt Paver**  
**ROADTEC RP170e or Equal (7020EC02)**

---

anticipated purchases only. No future use of the Contract or any individual item is guaranteed or implied.

Vendor should electronically enter the information into the Pricing Pages through wvOASIS, if available, or as an electronic document. In most cases, the Vendor can request an electronic copy of the Pricing Pages for bid purposes by sending an email request to the following address: Crystal.G.Hustead@wv.gov.

**5. ORDERING AND PAYMENT:**

**5.1 Ordering:** Vendor shall accept orders through wvOASIS, regular mail, facsimile, e-mail, or any other written forms of communication. Vendor may but is not required to accept on-line orders through a secure internet ordering portal/website. If Vendor has the ability to accept on-line orders, it should include in its response a brief description of how Agencies may utilize the on-line ordering system. Vendor shall ensure that its on-line ordering system is properly secured prior to processing Agency orders on-line.

**5.2 Payment:** Vendor shall accept payment in accordance with the payment procedures of the State of West Virginia.

**6. DELIVERY AND RETURN:**

**6.1 Delivery Time:** A completed pilot model for inspection must be provided within **120** working day(s) after receipt of the pilot model order, by the successful vendor. Vendor shall deliver standard orders within **180** working days after orders are received Working day is defined as any weekday, Monday thru Friday, excluding Federal and State Holidays. Vendor shall ship all orders until a minimum delivery quantity is met.

**6.2 Late Delivery:** The Agency placing the order under this Contract must be notified in writing if orders will be delayed for any reason. Any delay in delivery that could cause harm to an Agency will be grounds for cancellation of the delayed order, and/or obtaining the items ordered from a third party.

Any Agency seeking to obtain items from a third party under this provision must first obtain approval of the Purchasing Division.

**6.3 Delivery Payment/Risk of Loss:** Standard order delivery shall be F.O.B. Destination to the Agency's location. Vendor shall include the cost of standard order delivery charges in its bid pricing/discount and is not permitted to charge the Agency separately for such delivery. The Agency will pay delivery charges on all emergency orders provided that Vendor invoices those delivery costs as a separate charge with the original freight bill attached to the invoice.

**REQUEST FOR QUOTATION**  
**CRFQ DOT2000000028**  
**(WVDOH CLASS 503) Extendable width Wheeled Asphalt Paver**  
**ROADTEC RP170e or Equal (7020EC02)**

---

**6.4 Condition of Unit(s) Upon Delivery:** All units must arrive at the prescribed delivery point having been completely pre-serviced with oil, lubricants, and coolant. All prescribed precautions pertaining to first operations and break-in of the unit are to be posted conspicuously on the unit for ready observance by the operator.

**6.5 Delivery Point:** Delivery point of the completed representative unit will be the WVDOH, Equipment Division, 83 Brushy Fork Road Crossing, Buckhannon, WV 26201.

**7. VENDOR DEFAULT:**

**7.1** The following shall be considered a vendor default under this Contract.

**7.1.1** Failure to provide Contract Items in accordance with the requirements contained herein.

**7.1.2** Failure to comply with other specifications and requirements contained herein.

**7.1.3** Failure to comply with any laws, rules, and ordinances applicable to the Contract Services provided under this Contract.

**7.1.4** Failure to remedy deficient performance upon request.

**7.2** The following remedies shall be available to Agency upon default.

**7.2.1** Immediate cancellation of the Contract.

**7.2.2** Immediate cancellation of one or more release orders issued under this Contract.

**7.2.3** Any other remedies available in law or equity.

**8. MISCELLANEOUS:**

**8.1 No Substitutions:** Vendor shall supply only Contract Items submitted in response to the Solicitation unless a contract modification is approved in accordance with the provisions contained in this Contract.

**EXHIBIT B**

**EQUIPMENT PREVENTATIVE MAINTENANCE QUESTIONNAIRE**

THIS FORM MUST BE COMPLETED IN ITS ENTIRETY BY SUCCESSFUL BIDDER OR MANUFACTURER'S TECHNICAL REPRESENTATIVE PRIOR TO DELIVERY TO THE WVDOH.

DESCRIPTION: \_\_\_\_\_ MAKE: \_\_\_\_\_

MODEL: \_\_\_\_\_ YEAR: \_\_\_\_\_ PURCHASE AMOUNT: \_\_\_\_\_

ENGINE: MAKE: \_\_\_\_\_ MODEL: \_\_\_\_\_ FUEL TYPE: \_\_\_\_\_

HORSEPOWER: \_\_\_\_\_ CYLINDER: \_\_\_\_\_ ENGINE SERIAL: \_\_\_\_\_

COOLING SYSTEM CAPACITY: \_\_\_\_\_

BELTS:	DESCRIPTION:	PART NUMBERS:
	_____	_____
	_____	_____

GVW: \_\_\_\_\_ AXLE CAPACITY: FRONT: \_\_\_\_\_ REAR: \_\_\_\_\_

TIRES: FRONT MAKE & SIZE: \_\_\_\_\_

REAR MAKE & SIZE: \_\_\_\_\_

DIMENSIONS OF UNIT: LENGTH: \_\_\_\_\_ WIDTH: \_\_\_\_\_ LENGTH: \_\_\_\_\_

VENDOR CONTACT PERSON: \_\_\_\_\_ PHONE: \_\_\_\_\_

**PARTS:**

BATTERY MAKE: \_\_\_\_\_ MODEL: \_\_\_\_\_ CCA: \_\_\_\_\_

TOP OR SIDE POST: \_\_\_\_\_ DIMENSIONS: LENGTH \_\_\_\_\_ WIDTH \_\_\_\_\_ HEIGHT \_\_\_\_\_

SPARK PLUGS OR FUEL INJECTORS MAKE: \_\_\_\_\_ PART #: \_\_\_\_\_

FUEL PUMP OR INJECTION PUMP MAKE: \_\_\_\_\_ MODEL: \_\_\_\_\_

ALTERNATOR MAKE: \_\_\_\_\_ PART #: \_\_\_\_\_

STARTER MAKE: \_\_\_\_\_ PART #: \_\_\_\_\_

TURBO CHARGER MAKE: \_\_\_\_\_ PART #: \_\_\_\_\_

TRANS. MAKE: \_\_\_\_\_ MODEL: \_\_\_\_\_ AUTO/MANUAL: \_\_\_\_\_

HYDRAULIC PUMP MAKE: \_\_\_\_\_ MODEL: \_\_\_\_\_

FILTERS	MAKE	PART NO.	LUBRICANT	MANUFACTURER TYPE
OIL	_____	_____	ENGINE	_____
AIR INNER	_____	_____	TRANSMISSION	_____
AIR OUTER	_____	_____	POWER STEERING	_____
FUEL PRIMARY	_____	_____	HYDRAULIC	_____
FUEL SECONDARY	_____	_____	DIFFERENTIALS	_____
COOLANT	_____	_____	BRAKE FLUID	_____
HYDRAULIC	_____	_____	COOLANT	_____
OTHER	_____	_____	OTHER	_____

## West Virginia Ethics Commission



### Disclosure of Interested Parties to Contracts

Pursuant to *W. Va. Code* § 6D-1-2, a state agency may not enter into a contract, or a series of related contracts, that has/have an actual or estimated value of \$1 million or more until the business entity submits to the contracting state agency a Disclosure of Interested Parties to the applicable contract. In addition, the business entity awarded a contract is obligated to submit a supplemental Disclosure of Interested Parties reflecting any new or differing interested parties to the contract within 30 days following the completion or termination of the applicable contract.

For purposes of complying with these requirements, the following definitions apply:

*"Business entity"* means any entity recognized by law through which business is conducted, including a sole proprietorship, partnership or corporation, but does not include publicly traded companies listed on a national or international stock exchange.

*"Interested party"* or *"Interested parties"* means:

- (1) A business entity performing work or service pursuant to, or in furtherance of, the applicable contract, including specifically sub-contractors;
- (2) the person(s) who have an ownership interest equal to or greater than 25% in the business entity performing work or service pursuant to, or in furtherance of, the applicable contract. (This subdivision does not apply to a publicly traded company); and
- (3) the person or business entity, if any, that served as a compensated broker or intermediary to actively facilitate the applicable contract or negotiated the terms of the applicable contract with the state agency. (This subdivision does not apply to persons or business entities performing legal services related to the negotiation or drafting of the applicable contract.)

*"State agency"* means a board, commission, office, department or other agency in the executive, judicial or legislative branch of state government, including publicly funded institutions of higher education: Provided, that for purposes of *W. Va. Code* § 6D-1-2, the West Virginia Investment Management Board shall not be deemed a state agency nor subject to the requirements of that provision.

The contracting business entity must complete this form and submit it to the contracting state agency prior to contract award and to complete another form within 30 days of contract completion or termination.

*This form was created by the State of West Virginia Ethics Commission, 210 Brooks Street, Suite 300, Charleston, WV 25301-1804. Telephone: (304)558-0664; fax: (304)558-2169; e-mail: [ethics@wv.gov](mailto:ethics@wv.gov); website: [www.ethics.wv.gov](http://www.ethics.wv.gov).*



Purchasing Division  
 2019 Washington Street East  
 Post Office Box 50130  
 Charleston, WV 25305-0130

State of West Virginia  
 Request for Quotation  
 13 -- Equipment

Proc Folder: 615049

Doc Description: ADDENDUM # 1

Proc Type: Central Master Agreement

Date Issued	Solicitation Closes	Solicitation No	Version
2019-10-03	2019-10-11 13:30:00	CRFQ 0803 DOT2000000028	2

**BID RECEIVING LOCATION**

BID CLERK  
 DEPARTMENT OF ADMINISTRATION  
 PURCHASING DIVISION  
 2019 WASHINGTON ST E  
 CHARLESTON WV 25305  
 US

**VENDOR**

Vendor Name, Address and Telephone Number:

**LESLIE EQUIPMENT CO.  
 19 GOFF CROSSING DRIVE  
 CROSS LANES, WV 25313**

**FOR INFORMATION CONTACT THE BUYER**

Crystal G Hustead  
 (304) 558-2402  
 crystal.g.hustead@wv.gov

Signature X

FEIN #

55-0493180

DATE

10-11-2019

All offers subject to all terms and conditions contained in this solicitation

**ADDITIONAL INFORMATION:**

Addendum # 1 is issued for following reasons:

1. To Extend the Bid Opening Date and Time to Friday October 11, 2019 at 1:30pm.
2. To provide answer to vendors questions.
3. Attachment of the Pre-Bid sign-in sheets.

INVOICE TO	SHIP TO
DIVISION OF HIGHWAYS EQUIPMENT DIVISION RT 33 83 BRUSHY ROAD CROSSING, PO BOX 610 BUCKHANNON WV26201 US	DIVISION OF HIGHWAYS EQUIPMENT DIVISION 83 BRUSHY FORK RD CROSSING BUCKHANNON WV 26201 US

Line	Comm Ln Desc	Qty	Unit Issue	Unit Price	Total Price
1	Asphalt Paver	10.00000	EA		

Comm Code	Manufacturer	Specification	Model #
22101607			

**Extended Description :**

Extendable width wheeled asphalt paver, Roadtec RP170e or equal

**SCHEDULE OF EVENTS**

Line	Event	Event Date
1	MANDATORY PRE-BID MEETING	2019-09-12
2	VENDOR QUESTION DEADLINE	2019-09-23



**SOLICITATION NUMBER: CRFQ DOT2000000028**

**Addendum Number: 1**

---

The purpose of this addendum is to modify the solicitation identified as ("Solicitation") to reflect the change(s) identified and described below.

**Applicable Addendum Category:**

- Modify bid opening date and time
- Modify specifications of product or service being sought
- Attachment of vendor questions and responses
- Attachment of pre-bid sign-in sheet
- Correction of error
- Other

**Description of Modification to Solicitation:**

Addendum # 1 is issued for following reasons:

1. To Extend the Bid Opening Date and Time to Friday October 11, 2019 at 1:30pm.
2. To provide answer to vendors questions.
3. Attachment of the Pre-Bid sign-in sheets.

**Additional Documentation:** Documentation related to this Addendum (if any) has been included herewith as Attachment A and is specifically incorporated herein by reference.

**Terms and Conditions:**

1. All provisions of the Solicitation and other addenda not modified herein shall remain in full force and effect.
2. Vendor should acknowledge receipt of all addenda issued for this Solicitation by completing an Addendum Acknowledgment, a copy of which is included herewith. Failure to acknowledge addenda may result in bid disqualification. The addendum acknowledgement should be submitted with the bid to expedite document processing.



Purchasing Division  
 2019 Washington Street East  
 Post Office Box 50130  
 Charleston, WV 25305-0130

State of West Virginia  
 Request for Quotation  
 13 - Equipment

Proc Folder: 615049

Doc Description: ADDENDUM # 2 ASPHALT PAVER (7020EC02)

Proc Type: Central Master Agreement

Date Issued	Solicitation Closes	Solicitation No	Version
2019-10-08	2019-10-11 13:30:00	CRFQ 0803 DOT2000000028	3

**BID RECEIVING LOCATION**

BID CLERK

DEPARTMENT OF ADMINISTRATION

PURCHASING DIVISION

2019 WASHINGTON ST E

CHARLESTON

WV 25305

US

**VENDOR**

Vendor Name, Address and Telephone Number:

**LESLIE EQUIPMENT CO.  
 19 GOFF CROSSING DRIVE  
 CROSS LANES, WV 25313**

**FOR INFORMATION CONTACT THE BUYER**

Crystal G Hustead

(304) 558-2402

crystal.g.hustead@wv.gov

Signature X

FEIN #

55-0493180

DATE

10-11-2019

All offers subject to all terms and conditions contained in this solicitation

**ADDITIONAL INFORMATION:**

Addendum # 2 is issued for following reasons:

- 1. To clarify specifications

INVOICE TO	SHIP TO
DIVISION OF HIGHWAYS EQUIPMENT DIVISION RT 33 83 BRUSHY ROAD CROSSING, PO BOX 610 BUCKHANNON WV26201 US	DIVISION OF HIGHWAYS EQUIPMENT DIVISION 83 BRUSHY FORK RD CROSSING BUCKHANNON WV 26201 US

Line	Comm Ln Desc	Qty	Unit Issue	Unit Price	Total Price
1	Asphalt Paver	10.00000	EA		

Comm Code	Manufacturer	Specification	Model #
22101607			

**Extended Description :**  
Extendable width wheeled asphalt paver, Roadtec RP170e or equal

**SCHEDULE OF EVENTS**

Line	Event	Event Date
1	MANDATORY PRE-BID MEETING	2019-09-12
2	VENDOR QUESTION DEADLINE	2019-09-23

**SOLICITATION NUMBER: CRFQ DOT2000000028**

**Addendum Number: 2**

---

The purpose of this addendum is to modify the solicitation identified as ("Solicitation") to reflect the change(s) identified and described below.

**Applicable Addendum Category:**

- Modify bid opening date and time
- Modify specifications of product or service being sought
- Attachment of vendor questions and responses
- Attachment of pre-bid sign-in sheet
- Correction of error
- Other

**Description of Modification to Solicitation:**

1. To clarify specifications

No other changes

Bid opening remains 10/11/2019 at 1:30 PM

**Additional Documentation:** Documentation related to this Addendum (if any) has been included herewith as Attachment A and is specifically incorporated herein by reference.

**Terms and Conditions:**

1. All provisions of the Solicitation and other addenda not modified herein shall remain in full force and effect.
2. Vendor should acknowledge receipt of all addenda issued for this Solicitation by completing an Addendum Acknowledgment, a copy of which is included herewith. Failure to acknowledge addenda may result in bid disqualification. The addendum acknowledgement should be submitted with the bid to expedite document processing.

# ATTACHMENT A

CRFQ DOT2000000028

Addendum 2

To clarify specifications

**3.1.4.1** Engine shall be turbocharged; water-cooled (6) six-cylinder diesel

Clarification: Specification shall remain as written

**3.1.4.2** Engine shall be 174 hp minimum at 2200 rpm Tier 4 Final emissions compliant

Clarification: Minimum horsepower shall be 173

**ADDENDUM ACKNOWLEDGEMENT FORM**  
**SOLICITATION NO.: DOT200000028**

**Instructions:** Please acknowledge receipt of all addenda issued with this solicitation by completing this addendum acknowledgment form. Check the box next to each addendum received and sign below. Failure to acknowledge addenda may result in bid disqualification.

**Acknowledgment:** I hereby acknowledge receipt of the following addenda and have made the necessary revisions to my proposal, plans and/or specification, etc.

**Addendum Numbers Received:**

(Check the box next to each addendum received)

- |  |  |
|--|--|
| <input checked="" type="checkbox"/> Addendum No. 1 | <input type="checkbox"/> Addendum No. 6  |
| <input checked="" type="checkbox"/> Addendum No. 2 | <input type="checkbox"/> Addendum No. 7  |
| <input type="checkbox"/> Addendum No. 3            | <input type="checkbox"/> Addendum No. 8  |
| <input type="checkbox"/> Addendum No. 4            | <input type="checkbox"/> Addendum No. 9  |
| <input type="checkbox"/> Addendum No. 5            | <input type="checkbox"/> Addendum No. 10 |

I understand that failure to confirm the receipt of addenda may be cause for rejection of this bid. I further understand that any verbal representation made or assumed to be made during any oral discussion held between Vendor's representatives and any state personnel is not binding. Only the information issued in writing and added to the specifications by an official addendum is binding.

\_\_\_\_\_  
Leslie Equipment Co.  
Company  
\_\_\_\_\_  
*Paul Daniel*  
Authorized Signature  
\_\_\_\_\_  
10-11-2019  
Date

**NOTE:** This addendum acknowledgment should be submitted with the bid to expedite document processing.  
Revised 6/8/2012



Purchasing Division  
 2019 Washington Street East  
 Post Office Box 50130  
 Charleston, WV 25305-0130

State of West Virginia  
 Request for Quotation  
 13 - Equipment

Proc Folder: 615049

Doc Description: ADDENDUM #3 ASPHALT PAVER (7020EC02)

Proc Type: Central Master Agreement

Date Issued	Solicitation Closes	Solicitation No	Version
2019-10-10	2019-10-17 13:30:00	CRFQ 0803 DOT2000000028	4

**BID RECEIVING LOCATION**

BID CLERK  
 DEPARTMENT OF ADMINISTRATION  
 PURCHASING DIVISION  
 2019 WASHINGTON ST E  
 CHARLESTON WV 25305  
 US

**VENDOR**

Vendor Name, Address and Telephone Number:

**LESLIE EQUIPMENT CO.  
 19 GOFF CROSSING DRIVE  
 CROSS LANES, WV 25313**

**FOR INFORMATION CONTACT THE BUYER**

Crystal G Hustead  
 (304) 558-2402  
 crystal.g.hustead@wv.gov

Signature X

FEIN #

550493180

DATE

10-10-19

All offers subject to all terms and conditions contained in this solicitation



**ADDITIONAL INFORMATION:**

Addendum #3 is issued for following reasons:

1. To extend bid opening date
2. To modify specifications

INVOICE TO	SHIP TO
DIVISION OF HIGHWAYS EQUIPMENT DIVISION RT 33 83 BRUSHY ROAD CROSSING, PO BOX 610 BUCKHANNON WV26201 US	DIVISION OF HIGHWAYS EQUIPMENT DIVISION 83 BRUSHY FORK RD CROSSING BUCKHANNON WV 26201 US

Line	Comm Ln Desc	Qty	Unit Issue	Unit Price	Total Price
1	Asphalt Paver	10.00000	EA		

Comm Code	Manufacturer	Specification	Model #
22101607			

**Extended Description :**

Extendable width wheeled asphalt paver, Roadtec RP170e or equal

**SCHEDULE OF EVENTS**

<u>Line</u>	<u>Event</u>	<u>Event Date</u>
1	MANDATORY PRE-BID MEETING	2019-09-12
2	VENDOR QUESTION DEADLINE	2019-09-23

**SOLICITATION NUMBER: CRFQ DOT2000000028**  
**Addendum Number: 3**

---

The purpose of this addendum is to modify the solicitation identified as (“Solicitation”) to reflect the change(s) identified and described below.

**Applicable Addendum Category:**

- Modify bid opening date and time
- Modify specifications of product or service being sought
- Attachment of vendor questions and responses
- Attachment of pre-bid sign-in sheet
- Correction of error
- Other

**Description of Modification to Solicitation:**

1. To extend bid opening date to October 17, 2019 at 1:30 PM
2. To modify specifications

**Additional Documentation:** Documentation related to this Addendum (if any) has been included herewith as Attachment A and is specifically incorporated herein by reference.

**Terms and Conditions:**

1. All provisions of the Solicitation and other addenda not modified herein shall remain in full force and effect.
2. Vendor should acknowledge receipt of all addenda issued for this Solicitation by completing an Addendum Acknowledgment, a copy of which is included herewith. Failure to acknowledge addenda may result in bid disqualification. The addendum acknowledgement should be submitted with the bid to expedite document processing.

# ATTACHMENT A

**CRFQ DOT2000000028**  
**Addendum 3**

**The below specifications have been modified:**

**3.1.4.1 Engine shall be turbocharged water cooled 4- or 6-cylinder diesel engine.**

**3.1.4.2 Engine shall be 173 hp minimum at 2200 rpm-tier 4 Final emission compliant.**

**3.2.6.2 Full 5-year 6000 hours on Engine and emissions 100% parts and labor on 6-cylinder engine and 7-year 8000 hours on Engine and emissions on 4-cylinder engine 100% parts and labor.**

**ADDENDUM ACKNOWLEDGEMENT FORM**  
**SOLICITATION NO.: DOT2000000028**

**Instructions:** Please acknowledge receipt of all addenda issued with this solicitation by completing this addendum acknowledgment form. Check the box next to each addendum received and sign below. Failure to acknowledge addenda may result in bid disqualification.

**Acknowledgment:** I hereby acknowledge receipt of the following addenda and have made the necessary revisions to my proposal, plans and/or specification, etc.

**Addendum Numbers Received:**

(Check the box next to each addendum received)

- |  |  |
|--|--|
| <input checked="" type="checkbox"/> Addendum No. 1 | <input type="checkbox"/> Addendum No. 6  |
| <input checked="" type="checkbox"/> Addendum No. 2 | <input type="checkbox"/> Addendum No. 7  |
| <input checked="" type="checkbox"/> Addendum No. 3 | <input type="checkbox"/> Addendum No. 8  |
| <input checked="" type="checkbox"/> Addendum No. 4 | <input type="checkbox"/> Addendum No. 9  |
| <input type="checkbox"/> Addendum No. 5            | <input type="checkbox"/> Addendum No. 10 |

I understand that failure to confirm the receipt of addenda may be cause for rejection of this bid. I further understand that any verbal representation made or assumed to be made during any oral discussion held between Vendor's representatives and any state personnel is not binding. Only the information issued in writing and added to the specifications by an official addendum is binding.

Leslie Equipment Co.  
Company  
  
Authorized Signature  
10-10-19  
Date

**NOTE:** This addendum acknowledgement should be submitted with the bid to expedite document processing.

Revised 6/8/2012

Universal Class

# **SUPER 1703-3i**

## **WHEELED PAVER**



Maximum Paving Width 19 ft. 6 in. (5.95 m)  
Maximum Laydown Rate 770 tons/h (700 tonnes/h)  
Transport Width 8 ft. 6 in. (2.59 m)

 [www.voegele.info](http://www.voegele.info)

SUPER 1703-3i





# The Most Innovative Paver Technology



**The wheeled VÖGELE SUPER 1703-3i** is a cutting-edge 8-foot-class paver suitable for a wide variety of applications. Typical jobs are secondary roads and highways. Due to its compact design, the wheeled paver is also ideal for commercial and municipal applications.

With drive options (6x2, 6x4 and 6x6), the SUPER 1703-3i is a versatile machine. The wheeled paver features plenty of power and high mobility to handle the most varied paving jobs, even in confined spaces.

The SUPER 1703-3i also comes with the latest version of our operating system, the popular ErgoPlus 3, which has been enhanced with a number of new ergonomic and functional features. With its new mounting system, the paver operator's console can be shifted

conveniently and easily between the right and left sides of the operator's stand during operation. In addition, it now has a large color display that ensures good readability even in poor lighting conditions. The screed consoles have been completely redesigned, making operation of this new "Dash 3" machine even easier for the entire paving crew.

With its new Universal Class paver, VÖGELE also offers the right screed for every application. The SUPER 1703-3i can be combined with the VF 500, a screed with front-mounted extensions. The VF 500 Extending Screed is equipped with a vibration system.

All of these features make this Universal Class machine a truly SUPER paver!



SUPER 1703-3i

# The Highlights of the SUPER 1703-3i



**8-foot wheeled Universal Class paver** with a large range of applications and paving widths up to 19 ft. 6 in. (5.95 m)

**Powerful Cummins engine** complying with US EPA standard Tier 4f

**Innovative and reliable drive concept** for excellent traction behavior

**Perfect paving quality** due to perfect material management



**ErgoPlus 3** with numerous additional ergonomic and functional advantages.

**The right screed** for every application. The paver can be combined with the VF 500 Extending Screed.

# Efficiency, Performance and Low Fuel Consumption



**The driving force behind** this Universal Class paver is its powerful, four-cylinder diesel engine rated at 173 hp (129 kW).

**Both low fuel consumption** and low-noise operation are made possible by intelligent engine management with an ECO mode.





**Minimum input - maximum output:** All drive components, including the three-phase generator, are supplied from the central splitter gearbox and operate at maximum efficiency.

**With its high tractive power,** the wheeled SUPER 1703-3i perfectly combines high paving performance with maximum mobility.

# State of the Art Drive Technology

**Three main components** define the power unit of a SUPER 1703-3i: its modern, liquid-cooled diesel engine, a splitter gearbox flanged directly to the engine and a large cooler assembly.

The driving force in this power pack from VÖGELE is its Cummins diesel engine of type QSB4.5-C173. This four-cylinder engine delivers 173 hp (129 kW) at 2,000 rpm. Yet the fuel-saving ECO mode is sufficient for many applications. And even then, the SUPER 1703-3i still has a full 160 hp (119 kW) at its disposal. Moreover, the machine generates even less noise when running at just 1,700 rpm.

A large cooler assembly ensures that the power unit always delivers its full output. With innovative air routing and a variable-speed fan, temperatures

are continually maintained within the optimum range, significantly extending the service life of both the diesel engine and the hydraulic oil. A further advantage is that the machine can operate without difficulty in all climate regions worldwide.

All hydraulic elements are supplied with hydraulic oil directly from the splitter gearbox, the advantage being that all pumps and valves are combined in one spot that is easily accessible for maintenance work. Even the powerful and completely maintenance-free generator for screed heating is flanged directly onto the splitter gearbox.

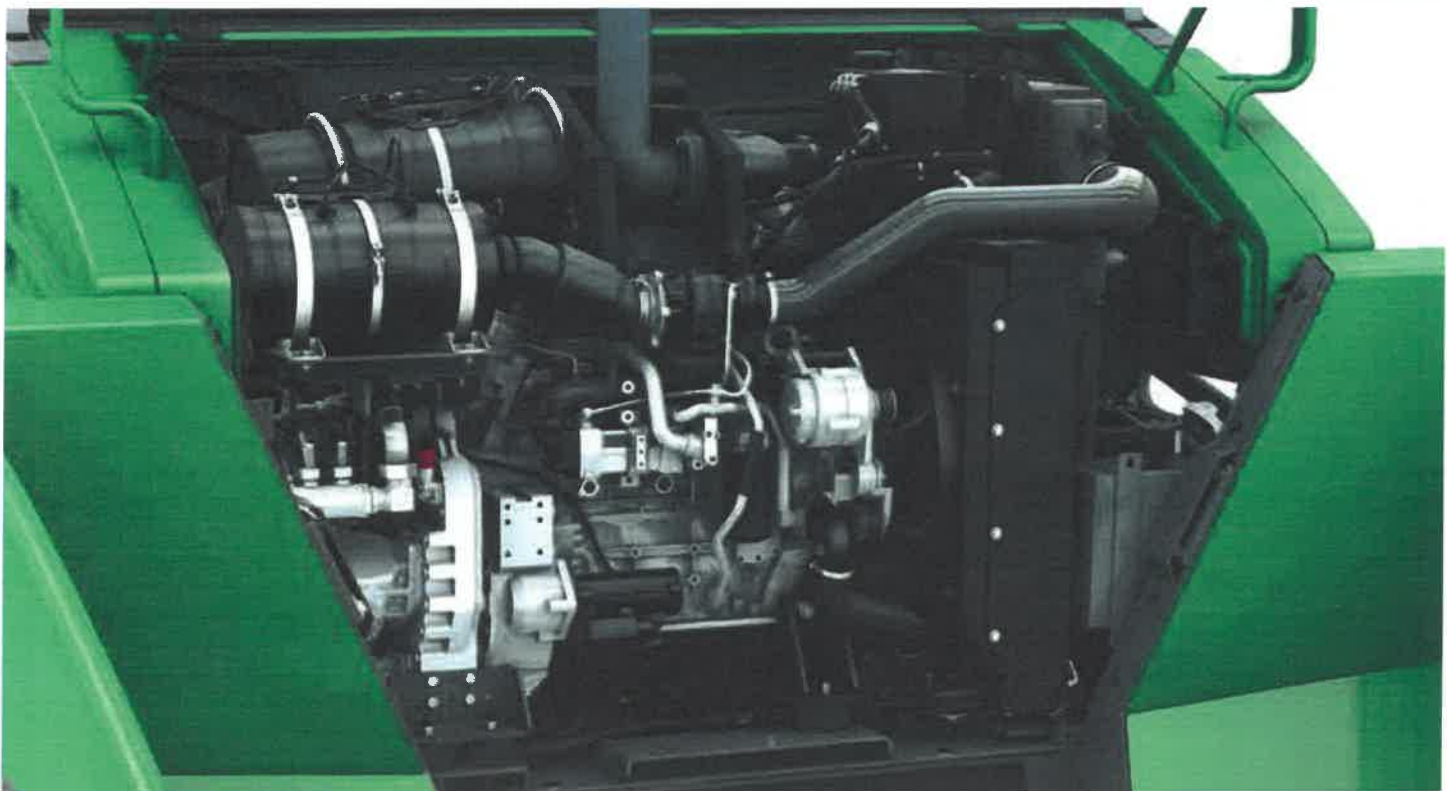

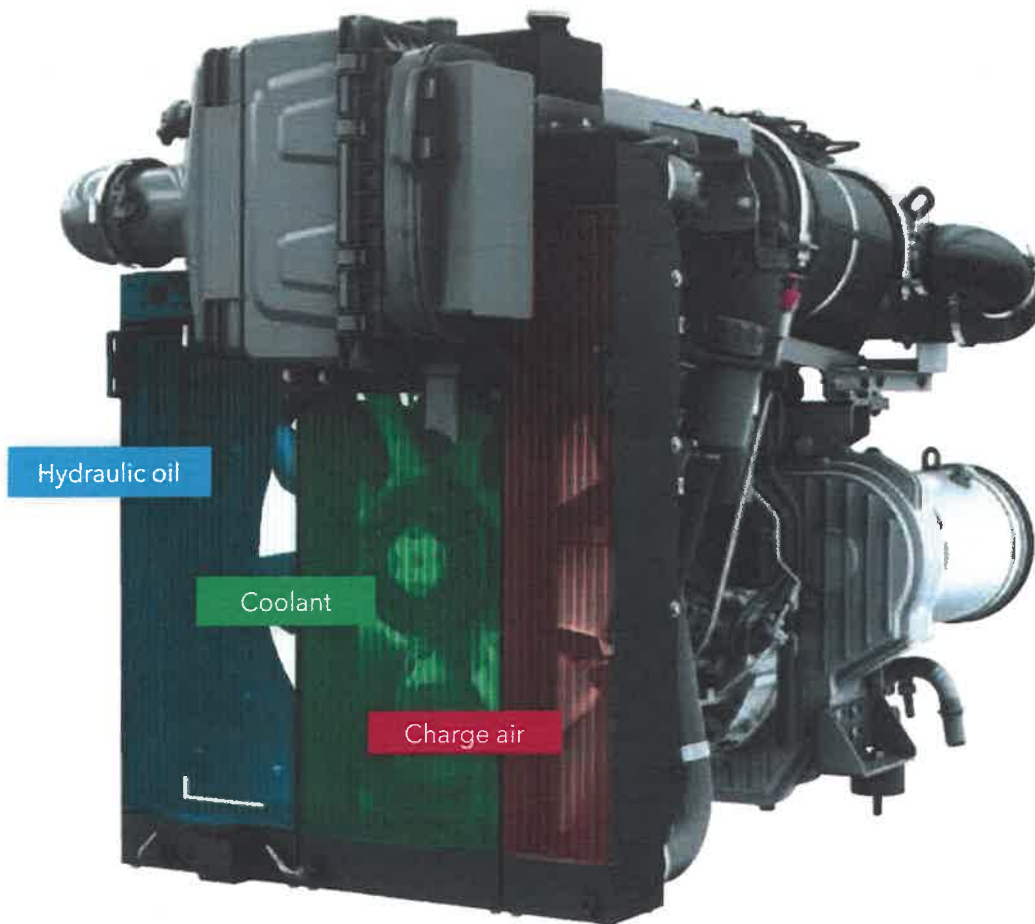

The large cooler assembly is made up of three parts. It ensures that engine coolant, charge air and hydraulic oil are maintained at the optimum temperature.

» **Machines with the suffix "i"** in their product designation are not only economical, but also extremely clean.

The "i" stands for "intelligent emission control" and is found in the type names of all machines from the WIRTGEN GROUP equipped with the latest engine technology. Thanks to their sophisticated exhaust gas after-treatment, these engines comply with the strict EPA and CARB standards Tier 4f.

» **Powerful 4-cylinder Cummins engine** delivers 173 hp (129 kW) at 2,000 rpm.

» **ECO mode** at 1,700 rpm provides low noise levels and low fuel consumption. ECO mode is sufficient for most paving applications.

» **Self-diagnostics** and sensors for almost all engine vitals simplify daily checks.

» **The fuel tank** holds 57 gallons (215 liters), more than enough for a day's work. The SUPER 1703-3i additionally has a DEF tank with sufficient capacity.

» **A powerful, air-cooled generator** with direct drive ensures rapid, uniform heating of the screed. The generator is directly driven by the splitter gearbox and therefore maintenance-free.



# Mobility on Wheels

With its high tractive power, the wheeled paver SUPER 1703-3i perfectly combines high paving performance with maximum mobility. This is assured by powerful separate hydraulic drives in the powered wheels. They ensure maximum traction when paving and allows the paver to maneuver quickly on the job site at speeds of up to 12 mph (20 km/h).

**Extreme maneuverability thanks to Pivot Steer.**

» **Rapid transport** under its own power at up to 12 mph (20 km/h) – a feat the SUPER 1703-3i is optimally equipped for. All paving functions are automatically deactivated when “Maneuvering” mode is selected.

» **Maximum power transmission** thanks to separate, hydraulic drives provided for both rear wheels. Optionally, an additional two (6x4) or four front wheels (all-wheel drive 6x6) can be driven.

» **Optimum traction** is assured, even on difficult terrain, by electronic traction management and an electronic differential lock acting on the drives of the rear wheels.

» **Continuous ground contact** is assured by the front wheels mounted on bogies. They provide for a permanent ground contact of the wheels also when working on an uneven base.

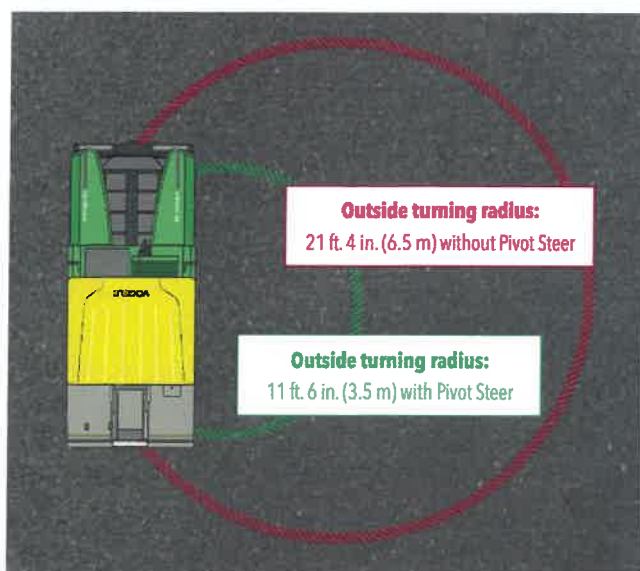

**Whenever maximum manoeuvrability** is required the paver operator can activate Pivot Steer. The rear inside wheel is then automatically slowed down hydraulically. This minimizes the outside turning radius to not more than 11 ft. 6 in. (3.5 m) for positioning maneuvers.





SUPER 1703-3i

## Precision Paving with Material Management

**A continuous flow of mix** is key to ensuring uninterrupted and high-quality paving. That is why we attach such importance to professional material management when designing our pavers.

Thanks to its large material hopper and conveyor tunnel, the SUPER 1703-3i can be supplied with mix easily and quickly.



The high-performance and precision systems that convey and spread the material support high laydown rates and consistent quality even at high paving speeds.



## Extra Large Material Hopper and Easy Material Feed



**The hydraulically operated hopper apron** prevents material spills during truck exchanges. It directs the material inside the hopper directly onto the conveyors, so no hand work is required. All of the mix is properly conveyed to the screed.

- » **The large material hopper** holds 14.3 tons (13 tonnes) and is dimensioned so that plenty of mix is stored at all times.
- » **Sloped inner design** of the hopper for an optimal flow of material to prevent segregation.
- » **Easy feeding with mix** thanks to only 24 in. (615 mm) dump height, wide hopper wings and sturdy rubber flashing fitted to the hopper apron.



» **Large oscillating push-rollers** can be set to 2 different positions for convenient and shock-free docking of feed vehicles even in curves.

» **A truck hitch** is available as an option.





# Precision Material Delivery Prevents Segregation

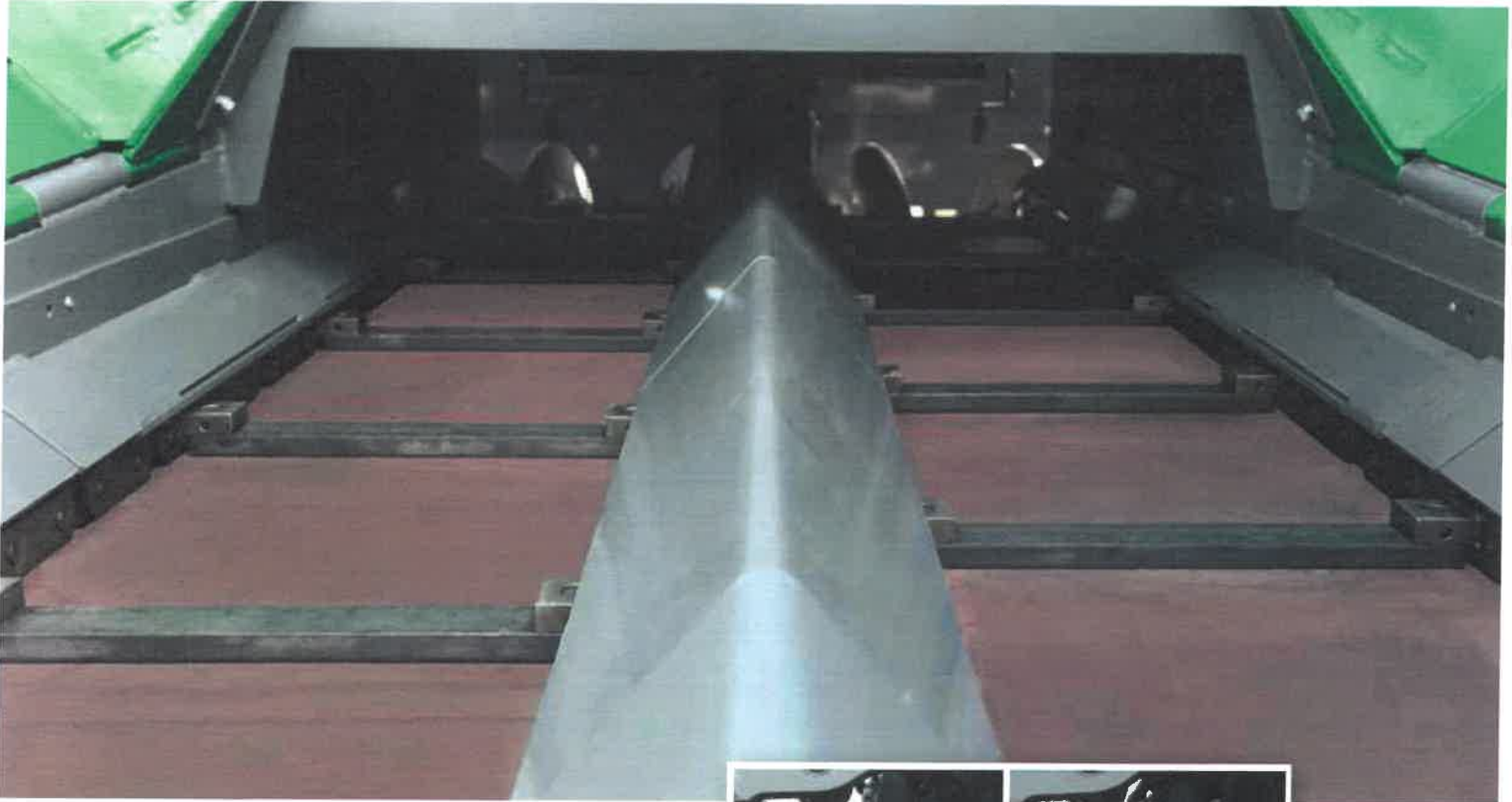

**Thanks to effective spreading of the material,** the SUPER 1703-3i always has an optimal head of mix in front of the screed to meet the demands of every paving situation.

The wide conveyor tunnel and powerful, hydraulic separate drives on the conveyors and augers support high laydown rates of up to 770 tons/h (700 tonnes/h).

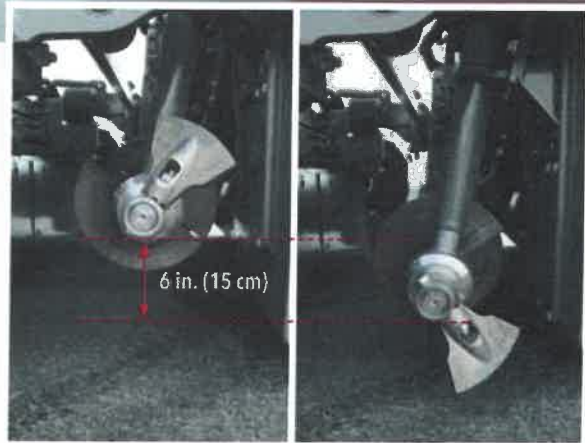

*Hydraulically adjustable augers are infinitely variable in height within a range of 6 in. (15 cm). Hydraulic auger height adjustment (including bearing boxes and limiting plates for the auger tunnel) provides optimal spreading of the material even when paving thin layers or on sections where thickness varies.*



» **Proportional control** and continuous monitoring of conveyors and augers guarantee a constant head of material in front of the screed.

» **Inclined conveyors** from the front to the rear of the machine provide ideal delivery of the material to the augers.

» **Large, 16 in. (40 cm) diameter auger flights** with precision pitch ensure excellent spreading of the material when paving in large widths or at lower engine rpm. VÖGELE's unique flight design provides prolonged service life versus standard flight designs.

» **Narrow conveyor guard** in the material hopper guarantees uniform material flow.



*The optional Power Tunnel is perfect for changing paving widths. The hydraulically adjusted limiting plates adapt to the screed width automatically, ensuring an optimal head of mix in front of the screed all the way to the end gates, even when the screed extensions are fully moved out.*





# The ErgoPlus 3 Operating System

**Even the very best machine** with the most advanced technology can only really show its strengths if it can be operated easily and as intuitively as possible. At the same time, it should offer an ergonomic and safe working environment for the operating team. Therefore, the ErgoPlus 3 operating system focuses on the operator. With VÖGELE pavers, the operator consequently retains full control over the machine and construction project.

On the following pages you will find detailed information on the extensive functions of the ErgoPlus 3 operating system. ErgoPlus 3 encompasses the operator's stand, the paver operator's console, the screed console and Niveltronic Plus, the System for Automatic Grade and Slope Control.



A man with a beard and sunglasses, wearing a bright green high-visibility safety vest over a light-colored striped polo shirt, is seated in the operator's seat of a piece of heavy machinery. He is looking forward and to the right, with his hands on the controls. The background shows a wooded area with trees in autumn colors. The machine's control panel, featuring several buttons and a joystick, is visible in the foreground.

***“Full Control for the***



# The Paver Operator's **ErgoPlus 3** Console

ERGOPLUS 3

A close-up, first-person perspective shot from the operator's seat of a paver machine. The operator's right hand is raised in a thumbs-up gesture, while the left hand rests on the steering wheel. The console is filled with various buttons and controls. In the background, a white paver machine is spreading material on a road, with a white car and a traffic cone nearby. The scene is set outdoors with trees and a clear sky.

# *Machine Operator"*

# The Paver Operator's ErgoPlus 3 Console

## "Pivot Steer" steering brake

The "Pivot Steer" steering brake can be switched on with a simple push of a button in the "Positioning" and "Paving" Modes. When activated, the speed of the rear inside wheel is automatically slowed down hydraulically when a steering movement is carried out. This reduces the turning radius to a minimum.



## Choice of operating modes for the paver

On the ErgoPlus 3 console, four different paver operating modes are available for selection. By pressing the arrow buttons, up or down, the operator changes modes in the following order: "Neutral", "Maneuvering Mode", "Positioning Mode" and "Paving Mode". An LED indicates the mode selected. When leaving "Paving Mode", a smart Memory feature stores the last settings for paver functions so that, when resuming work after a move of the paver on site, these settings are restored automatically.



## Automatic functions

For conveyors and augers, operators can easily select "Manual Mode" or "Automatic Mode". When selecting "Automatic Mode" for the augers, sensors installed for the material level in the auger tunnel provide exactly the desired amount of mix for spreading in front of the screed.



## Safe operation during the night

Glarefree backlighting comes on automatically as darkness sets in so that the paver operator can also work safely on night-time jobs.





**The paver operator's ErgoPlus 3 console** has been designed according to practice-related principles. All controls are clearly arranged. Paver functions are clustered in logical groups so that operators find their controls just where they would expect them to be.

On the ErgoPlus 3 console, all push-buttons are easily identifiable by touch even when wearing work gloves. Once a button is pressed, off you go. The benefit of the „Touch and Work“ principle. This means that a function is executed directly - without the need to confirm.

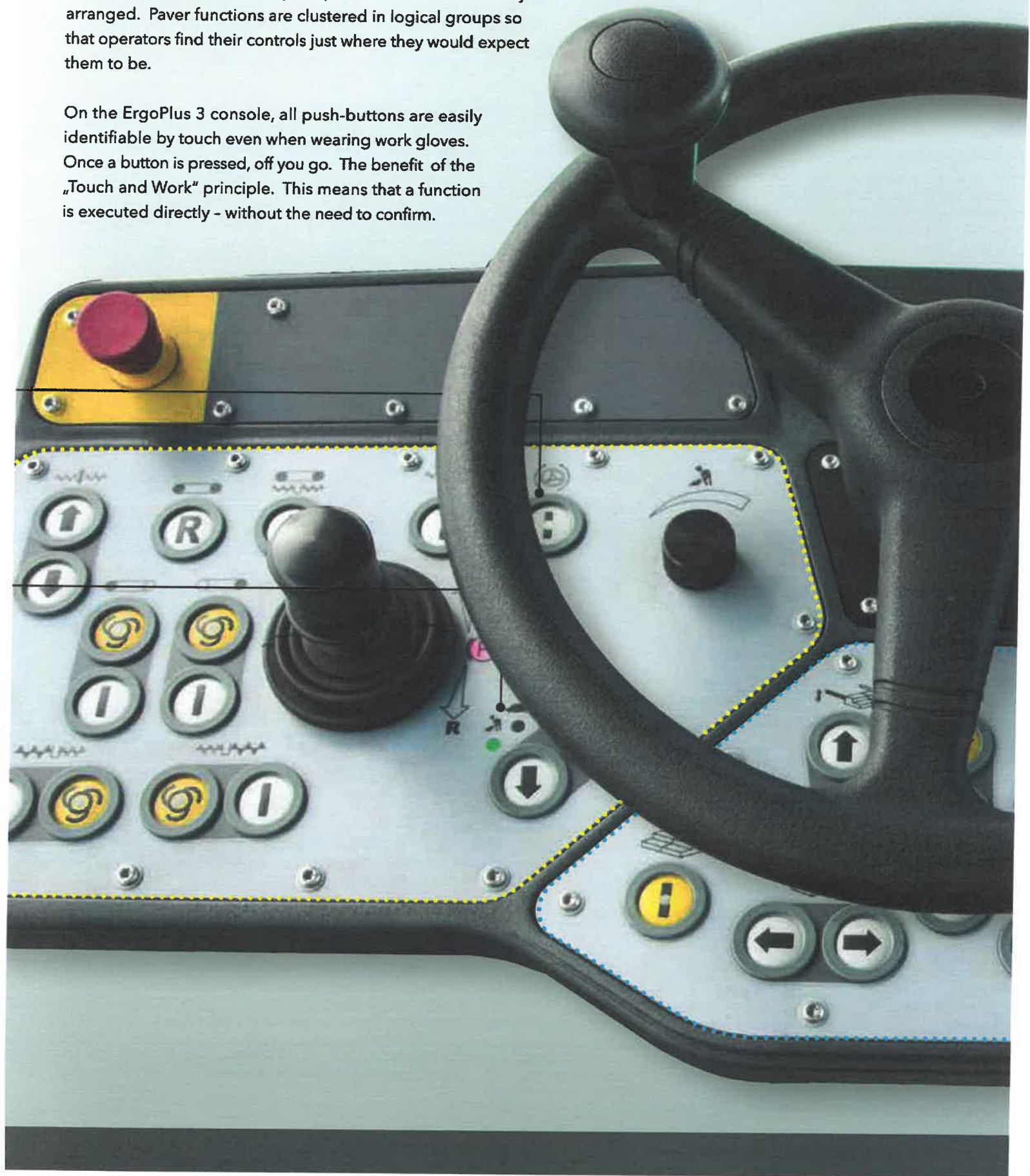



VÖGELE

mile/h  
00  
F2  
F4  
F6  
F8  
M2  
M3  
M4  
ESC

START/STOP

MAX



- **Module 1:** Conveyors and Augers, Traction
- **Module 2:** Screed
- **Module 3:** Material Hopper and Steering
- **Module 4:** Display for monitoring and adjustment of basic settings

**Display of the paver operator's console**

The redesigned color display has a high-contrast user interface ensuring brilliant readability even in poor lighting conditions. Vital information is shown on menu level 1, such as the positions of the screed tow point cylinders or the material level in the conveyor tunnel. Further paver functions such as speed for vibration or feed rates for the conveyors can easily be set up via the display, too. And the display gives access to machine-related information such as fuel consumption or service hours.

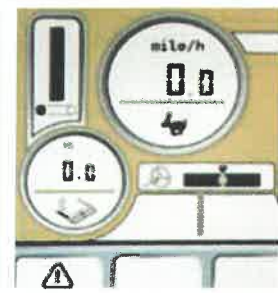

**Choice of engine speed ranges**

For the engine, there is a choice of three modes to select from: MIN, ECO and MAX. To switch modes for engine rpm, all the operator needs to do is press the arrow buttons, up or down. In ECO Mode, the engine delivers sufficient power for a great number of paving applications. Operating in ECO Mode reduces noise emission and fuel consumption considerably.



**Hopper wings and hydraulic hopper apron**

The hydraulically operated hopper apron prevents spills of material when changing feed trucks. The two hopper wings can be folded separately or both together at the push of a button.

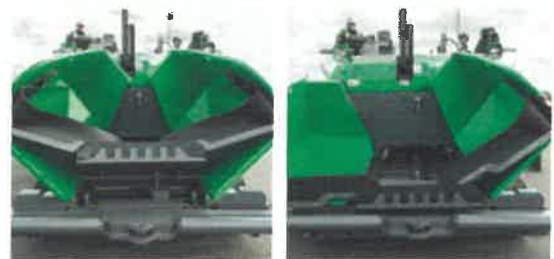

**Screed Assist (option)**

This button switches Screed Assist on (LED lights up) or off. The screed Assist pressure and balance can be set via the display. Screed Assist is active only when the screed is floating.







# The ErgoPlus 3 Screed Console

## The screed is crucial for pavement quality.

Therefore, easy and positive handling of all screed functions is of utmost importance for high-quality road construction.

With ErgoPlus 3, the screed operator has the process of paving at his fingertips. All functions are easily comprehensible and all controls are clearly arranged.

### The screed console

The screed console is designed in keeping with the conditions prevailing on the job site. Push-buttons are provided for the frequently used functions operated from the screed console. These are watertight and enclosed in palpably raised rings, so that they are identifiable blindfolded simply by touch even when wearing work gloves. Important paver and screed data can be called up and adjusted from the screed console, too.



### The display of the screed console

The screed console display allows the screed operator to control and monitor both the left and the right side of the screed. Machine-related parameters such as vibration speed or conveyor speed can be adjusted conveniently via the display panel of the screed console. The clear menu structure, combined with easily understandable, self-explanatory symbols neutral in language, makes operating the display panel both simple and safe.



### Crown adjustment at the press of a button

The crown can be conveniently adjusted at the press of a button on the screed operator's console. When pressing the "plus" or "minus" keys, the set crown value is shown on a pop-up window. The conveyors and augers are adjusted accordingly.



### Ergonomic screed width control in two speeds

The screed width can be effortlessly adjusted by means of the "SmartWheel". This is done in two speeds: slow, for precise control e.g. along an edge, or fast, for rapid extension or retraction of the screed.



### Optimum visibility even in darkness

The screed console is specially designed for night-time operation. To prevent operator errors, the buttons are backlit as soon as dusk falls or in darkness. What's more, the downward-angled high-power LED lighting gives the operator a perfect view of all processes associated with the end gate.





# The ErgoPlus 3 Remote Control

**In addition to the screed operating consoles,** a compact and very durable remote control is available for each side of the VF 500 screed.

The remote controls can be securely stowed in the holders on the main screed, or on the ends of the screed extensions.



The holders are magnetic, meaning that the remote controls are easy to grab at any time, giving the operator a large radius of movement so that he can always find the most effective working position in any paving situation.

**All the main paving functions** of the screed can be controlled using one of the two handy screed remote controls. Intuitive operation is possible thanks to self-explanatory and language-neutral symbols.

- 1 // Setting:** Conveyor, automatic / manual
- 2 // Setting:** Auger, automatic / manual
- 3 // Setting:** Screed, tow point cylinder
- 4 // Control:** Screed width
- 5 // Setting:** Power Tunnel, automatic / manual
- 6 // Setting:** Berm
- 7 // Setting:** Slope
- 8 // Setting:** Screed extension, height
- 9 // Lock:** Screed extension





# VÖGELE Niveltronic Plus

**Niveltronic Plus**, the System for Automatic Grade and Slope Control, is an in-house development by VÖGELE based on many years of experience in grade and slope control technology. Easy operation, precision and reliability are its hallmarks, ensuring perfect mastery of all grade and slope control jobs.

This fully integrated system is optimally adapted to the machine technology of the SUPER pavers. All wiring and connections, for instance, are integrated into the tractor, effectively eliminating all risk of damage to these components.

VÖGELE naturally offer a particularly large and practical selection of sensors permitting versatile use of the Niveltronic Plus system. Whether for instance car parks, roundabouts or highways need to be built or rehabilitated, VÖGELE offer the right sensor for every job site situation.

Sensors can be changed quickly and easily, for Niveltronic Plus automatically detects which sensor is connected, thus simplifying the configuration process for the user.

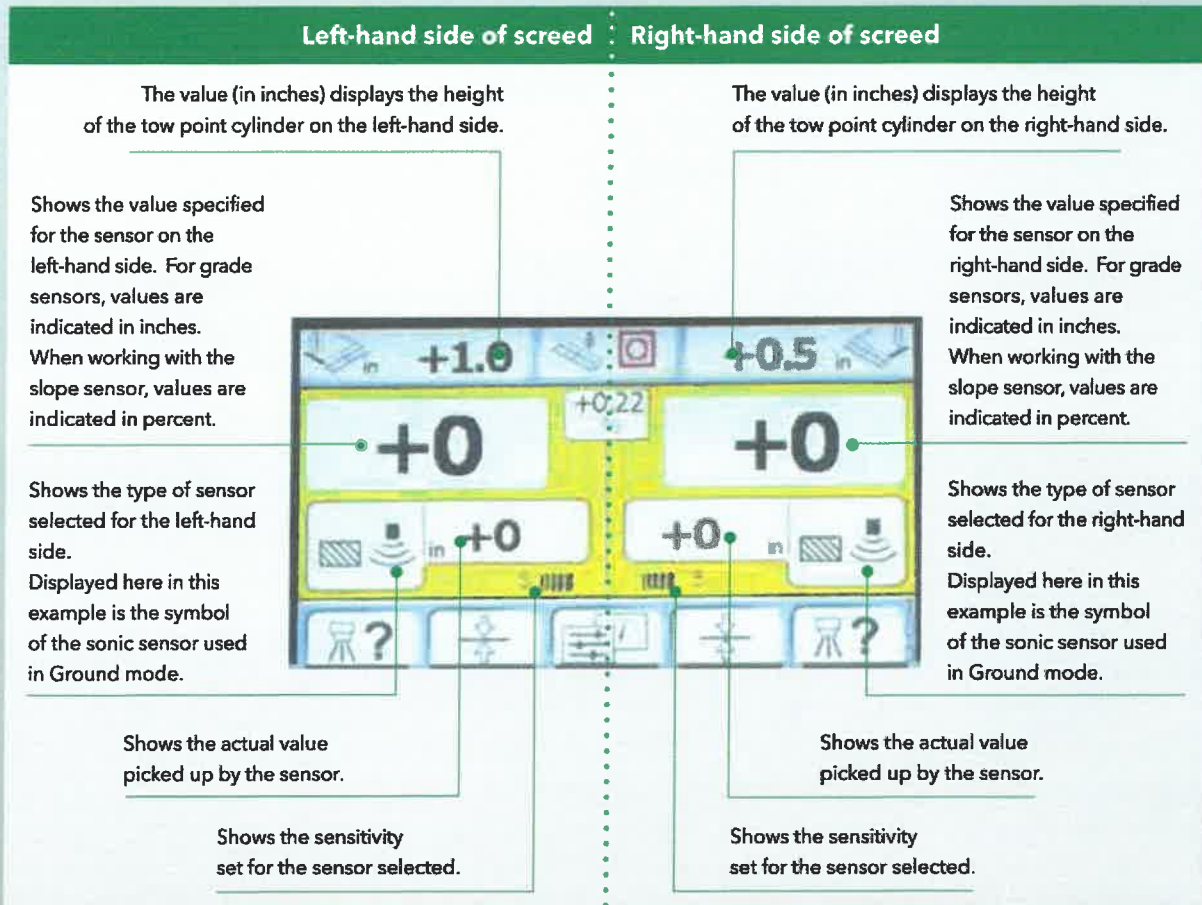

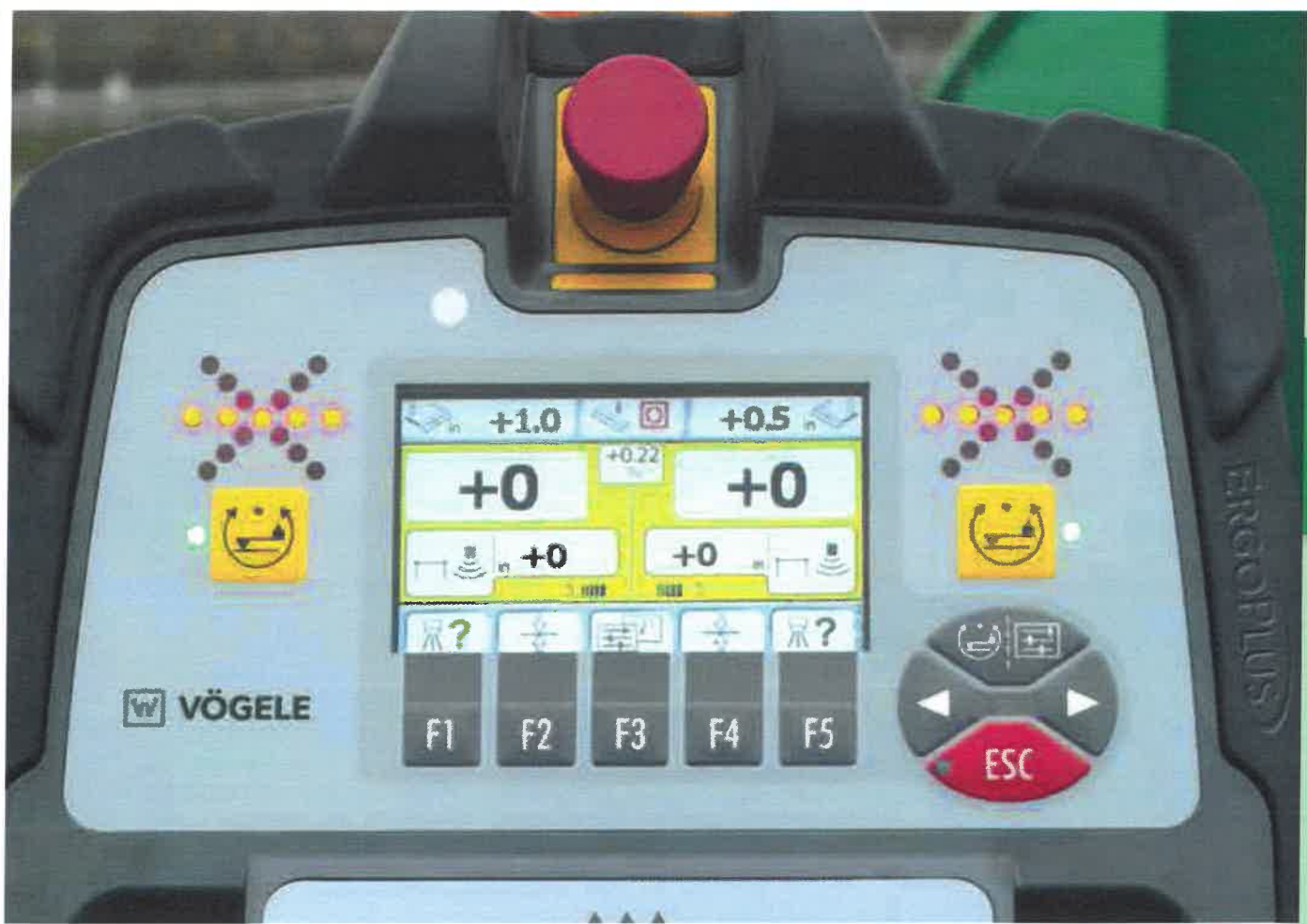

ERGOPLUS 3







## The ErgoPlus 3 Operator's Stand

**1. The comfortable operator's stand** gives an unobstructed view of all crucial areas on the paver such as material hopper, steering guide or screed. It allows the paver operator to closely monitor the paver's feed with mix and the process of paving.

**2. The seat swings out** to the sides, and streamlined operator's stand provides for maximum visibility of the auger tunnel, permitting the paver operator to keep an eye on the head of mix in front of the screed at all times.

### **3. Working comfort**

On the "Dash 3" machines, the paver operator's seat and console, as well as the screed consoles can now be adjusted even more easily to personal requirements.

### **4. A place for everything and everything in its place**

The operator's stand, with its streamlined design, is well organized, offering the paver operator a professional workplace. The operator's console can be protected by a shatter-proof cover to prevent willful damage.





**5. Hardtop gives excellent protection**

The modern hardtop made of glass fiber reinforced polymer material shelters the operator whether rain or shine.

**6. Consistent service concept**

All "Dash 3" pavers have a consistent maintenance concept with identical service intervals.

**7. Ergonomic screed console**

The height and position of the console are easily adjusted. The high-contrast color display can be read clearly from all angles.

**8. Easy transport**

The machine can be prepared quickly and easily for transport on a low-bed trailer. Even the hardtop can be folded down to transport position using a manual hydraulic pump.







## VF 500 Extending Screed

**Stability and variability** are not mutually exclusive, as the front-mounted VF 500 Extending Screed from VÖGELE proves. With a basic width from 8 ft. to 15 ft. 6 in. (2.45 m to 4.75 m) and a maximum paving width of 19 ft. 6 in. (5.95 m) with bolt-on extensions it is the ideal tool for multivariable width applications and mainline paving. The unique VÖGELE telescoping system allows screed width control, accurate to the millimeter. The variability is also evidenced in the range of possible profiles: crowns, transverse slopes and berms are set once and then built perfectly from the start to the end of paving process. The compacting system provides great mat texture and excellent compaction. So for the SUPER 1703-3i, the VF 500 Extending Screed is the perfect match.

### Electric screed heating

A consistent surface texture is achieved by uniform heating of the screed plates. With the engine running at minimum rpm, the time required for the screed to reach operating temperature is reduced substantially due to an intelligent generator management system. With paver functions set to automatic, the generator management system activates Alternating mode for screed heating (heats the screed alternately on the left and right), a feature which reduces engine wear and fuel consumption.



# The Screed for the SUPER 1703-3i

## VF 500 V

### Paving widths

- » Infinitely variable range from 8 ft. to 15 ft. 6 in. (2.45 m to 4.75 m).
- » Maximum paving width through bolt-on extensions:
  - > 17 ft. 6 in. (2 x 12 in.) / 5.35 m (2 x 30 cm).
  - > 19 ft. 6 in. (2 x 24 in.) / 5.95 m (2 x 60 cm).

### Compacting system

- » VF 500 V with vibration

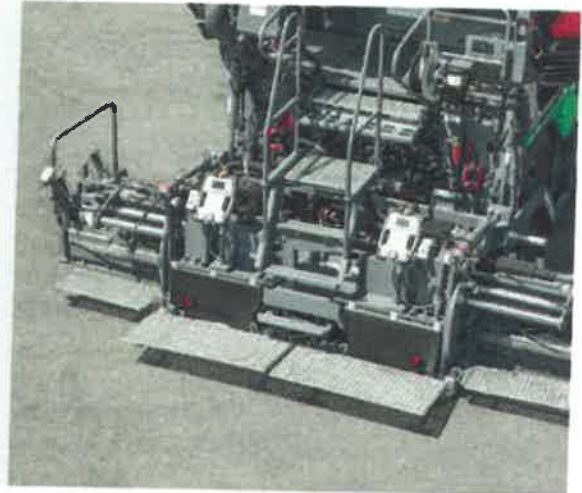

VF 500 V without bolt-on extensions

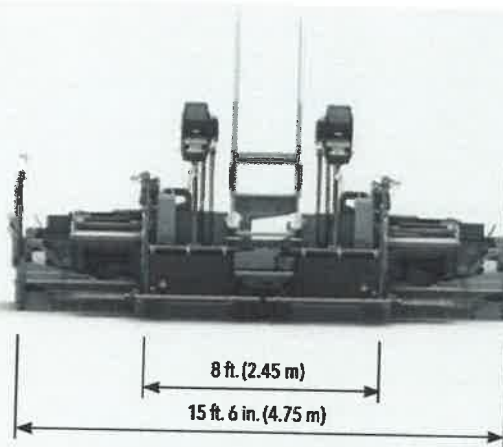

VF 500 V with 24 in. (60 cm) bolt-on extensions

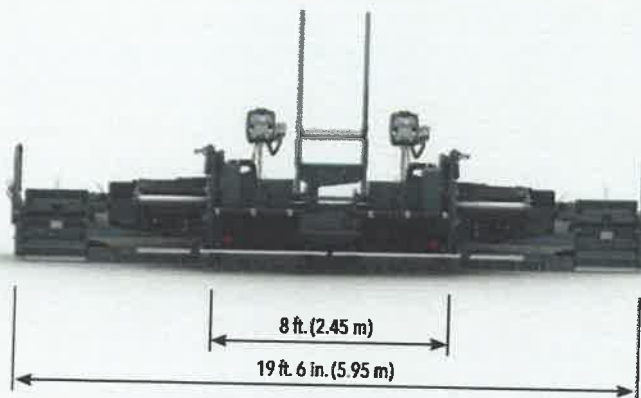



# All the Facts at a Glance

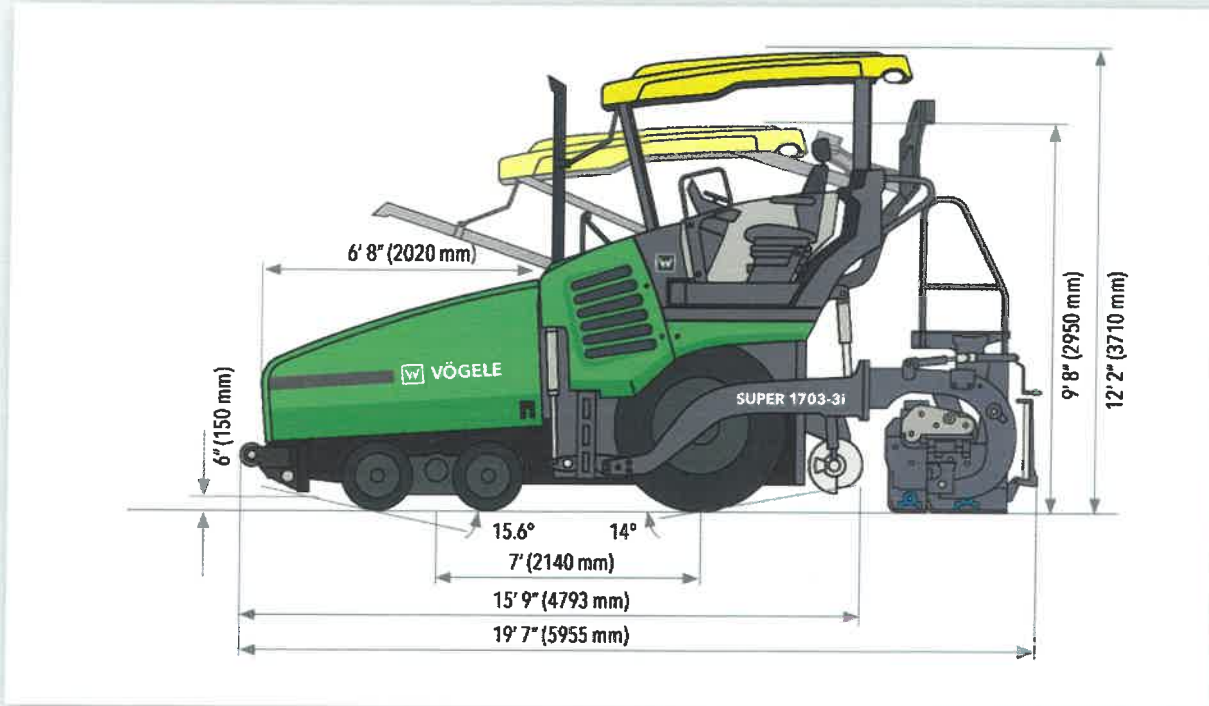

Power Unit	
Engine	4-cylinder diesel engine, liquid-cooled
Manufacturer	Cummins
Type	QS84.5 - C173
Output	
Nominal	173 hp (129 kW) at 2,000 rpm (according to DIN)
ECO mode	160 hp (119 kW) at 1,700 rpm
Exhaust Emissions	
Standard	EU Stage 4, US EPA Tier 4f
Exhaust after-treatment	DOC, SCR
Fuel tank	57 gallons (US) (215 liters)

Undercarriage	
Front Wheels	4, mounted on bogies (oscillating axle)
Tire Equipment	solid tires
Tire Size	540/300 - 390
Rear Wheels	2, pneumatic tires, tubeless
Tyre Size	14.00 R25
Traction Drive	separate hydraulic drive provided for each wheel
Standard	2 rear wheels powered (6x2)
Option	2 rear wheels and 2 front wheels powered (6x4)
Option	2 rear wheels and 4 front wheels powered (6x6)

Undercarriage	
Speeds	
Paving	up to 250 fpm (76 m/min.)
Travel	up to 12 mph (20 km/h)
Outside Turning Radius	minimum of 11 ft. 6 in. (3.5 m) with Pivot Steer

Material Hopper	
Hopper Capacity	14.3 tons (13 tonnes)
Width	10 ft. 9 in. (3,265 mm)
Feed Height	24 in. (615 mm)
Push-Rollers	
Standard	oscillating
Positions	can be displaced forwards by 3 in. (75 mm) or 6 in. (150 mm)
Option	truck hitch

Conveyors and Augers	
Conveyors	2, with replaceable feeder bars, conveyor movement reversible for a short time
Drive	separate hydraulic drive provided for each conveyor
Speed	up to 130 fpm (40 m/min.), infinitely variable (manual or automatic)

**Key:** DOC = Diesel Oxidation Catalyst    VF = Screed with Front-Mounted Extensions  
 SCR = Selective Catalytic Reduction    V = with vibration



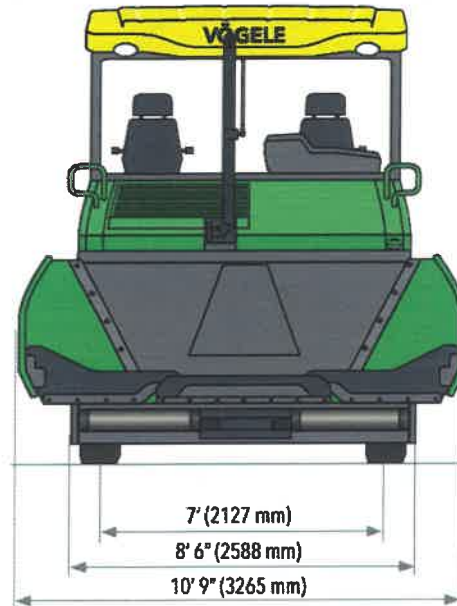

**Conveyors and Augers**

<b>Augers</b>	2, with exchangeable auger blades, auger rotation reversible
<b>Diameter</b>	16 in. (400 mm)
<b>Drive</b>	separate hydraulic drive provided for each auger
<b>Speed</b>	up to 120 rpm, infinitely variable (manual or automatic)
<b>Height</b>	infinitely variable by 6 in. (15 cm), hydraulic
<b>Lubrication</b>	automatic centralized lubrication system with electrically driven grease pump

**Screed Options**

<b>VF 500</b>	infinitely variable range	8 ft. to 15 ft. 7 in. (2.45 m to 4.75 m)
	maximum width	19 ft. 6 in. (5.95 m)
<b>Screed Version</b>	V	
<b>Layer Thickness</b>	up to 12 in. (30 cm)	
<b>Screed Heating</b>	electrically by heating rods	
<b>Power Supply</b>	three-phase A.C. generator	

**Dimensions (Transport) and Weights**

<b>Width</b>	8 ft. 6 in. (2.59 m)
<b>Length</b>	tractor and screed
<b>VF 500 V</b>	19 ft. 7 in. (5.96 m)
<b>Weights</b>	tractor, hardtop and screed
<b>VF 500 V</b>	38,140 lbs. (17.3 t)

Technical alterations reserved.



The VÖGELE QR Code leads you directly to the "SUPER 1703-3i" on our website.



® ERGOPLUS, InLine Pave, NAVITRONIC, NAVITRONIC Basic, NAVITRONIC Plus, NIVELTRONIC, NIVELTRONIC Plus, RoadScan, SprayJet, VÖGELE, VÖGELE PowerFeeder, PaveDock, PaveDock Assistant, AutoSet, AutoSet Plus, AutoSet Basic, ErgoBasic and VÖGELE-EcoPlus are registered Community Trademarks of JOSEPH VÖGELE AG, Ludwigshafen/Rhein, Germany. PCC is a registered German Trademark of JOSEPH VÖGELE AG, Ludwigshafen/Rhein, Germany. ERGOPLUS, NAVITRONIC Plus, NAVITRONIC BASIC, NIVELTRONIC Plus, SprayJet, VISION, VÖGELE, VÖGELE PowerFeeder, PaveDock, PaveDock Assistant, AutoSet, AutoSet Plus, AutoSet Basic and VÖGELE-EcoPlus are trademarks registered in the US Patent and Trademark Office to JOSEPH VÖGELE AG, Ludwigshafen/Rhein, Germany. Legally binding claims cannot be derived from written information or pictures contained in this brochure. Pictures may include optional extras. We reserve the right of technical or design alterations.

**Wirtgen America**

6030 Dana Way · Antioch, TN 37013, USA  
Phone: (615) 501-0600 · Fax: (615) 501-0691  
Internet: [www.wirtgenamerica.com](http://www.wirtgenamerica.com)





#### 4.15 Statement of Warranty

Wirtgen America warrants such equipment, parts, and other products as are manufactured by Wirtgen America against defective material or workmanship for a period of twelve months after date of first delivery or for 1,000 hours of use with any Wirtgen, Vögele and Hamm product and 2000 hours of use with any Kleemann product, whichever comes first, provided that the Buyer sends Wirtgen America a notice of the defect within 30 days of its discovery and clearly establishes that (1) the equipment, parts, etc., have been properly installed and setup, maintained, and operated within the limits of rated and normal usage and (2) that the defect did not result in any manner from the intentional or negligent action or inaction of the Buyer; further provided that Buyer cannot establish that conditions (1) and (2) have been met, then this warranty shall not cover the alleged defect. Failure to give notice of defect within such period shall be a waiver of this Warranty and assistance rendered thereafter shall not extend or revive it. **WIRTGEN AMERICA MAKES NO SUCH WARRANTIES WITH RESPECT TO PARTS OR EQUIPMENT NOT MANUFACTURED BY WIRTGEN AMERICA, SUCH AS ENGINES, MOTORS, CLUTCHES, SPEED REDUCERS, PUMPS AND OTHER ASSEMBLIES, VALVES, SOLENOIDS, AND OTHER PARTS AND ACCESSORIES.** Accessories, assemblies, and components included in products of Wirtgen America, which are not manufactured by Wirtgen America, are subject only to the warranty of their respective manufacturers.

This warranty shall not cover misuse, alteration, abuse, negligence, accident, acts of God, sabotage, or any item on which serial numbers have been altered, defaced, or removed but shall be limited to repair or replacement, F.O.B., Wirtgen America facility, of those parts which upon inspection by Wirtgen America appear to have been defective in material or workmanship. Wirtgen America will, at its option, use genuine Wirtgen Group or remanufactured parts. Wirtgen Group replacement parts that are used in a repair are covered by the Wirtgen America replacement warranty. Parts such as liners, cutting edges, rubber flashing, conveyor belting, castings, vibrators, teeth, and other wear parts, which are subject to wide variations or destructive service, are not covered by this Warranty and are the maintenance responsibility of the Buyer from the beginning of operation. **THIS WARRANTY IS LIMITED TO THE BUYER AND IS NOT ASSIGNABLE OR OTHERWISE TRANSFERABLE.**

**THIS WARRANTY IS EXPRESSLY IN LIEU OF AND EXCLUDES ALL OTHER WARRANTIES EXPRESSED OR IMPLIED (INCLUDING ANY WARRANTY OF MERCHANTABILITY AND FITNESS OF ANY PRODUCT OR GOODS FOR A PARTICULAR PURPOSE) AND ALL OTHER OBLIGATIONS OR LIABILITIES ON WIRTGEN AMERICA'S PART, AND WIRTGEN AMERICA NEITHER ASSUMES NOR AUTHORIZES ANY OTHER PERSON TO ASSUME FOR WIRTGEN AMERICA ANY OTHER LIABILITY IN CONNECTION WITH THE SALE OF WIRTGEN AMERICA'S PRODUCTS. THERE ARE NO WARRANTIES THAT EXTEND BEYOND THE DESCRIPTION ON THE FACE HEREOF.**

#### LIMITATION OF LIABILITY

It is agreed that in the event of breach of any warranty by WIRTGEN AMERICA the liability of WIRTGEN AMERICA shall be limited exclusively to the remedies of repair or replacement of defective parts covered by the Warranty set forth in the paragraph WARRANTY ON EQUIPMENT above and that such repair and replacement shall be Buyer's sole and exclusive remedy. WIRTGEN AMERICA shall not have any liability whatsoever for loss of use or for any other incidental, consequential, or other damages or losses resulting from a breach of warranty, such as, but not by way of limitation, labor costs, loss of profits, loss of use of other than equipment, third party repairs, personal injury, emotional or mental distress, improper performance of work, penalties of any kind, loss of service of personnel, or any other damages or losses which may be experienced by the Buyer.

Wirtgen America, Inc.  
Wirtgen America Machine Warranty  
WAI 08-13/Rev 2-05