



The following documentation is an electronically-submitted vendor response to an advertised solicitation from the *West Virginia Purchasing Bulletin* within the Vendor Self-Service portal at wvOASIS.gov. As part of the State of West Virginia's procurement process, and to maintain the transparency of the bid-opening process, this documentation submitted online is publicly posted by the West Virginia Purchasing Division at WVPurchasing.gov with any other vendor responses to this solicitation submitted to the Purchasing Division in hard copy format.

Header 2

List View

General Information | Contact | Default Values | Discount | Document Information

Procurement Folder: 575001	SO Doc Code: CRFQ
Procurement Type: Central Master Agreement	SO Dept: 0803
Vendor ID: 000000198312	SO Doc ID: DOT1900000125
Legal Name: RISH EQUIPMENT COMPANY	Published Date: 7/12/19
Alias/DBA:	Close Date: 7/25/19
Total Bid: \$10,178,950.00	Close Time: 13:30
Response Date: 07/25/2019	Status: Closed
Response Time: 13:29	Solicitation Description: ADDENDUM 1 4WD RUBBER TIRED WHEEL LOADER W/BUCKET
Total of Header Attachments: 2	
Total of All Attachments: 2	



Purchasing Division
 2019 Washington Street East
 Post Office Box 50130
 Charleston, WV 25305-0130

**State of West Virginia
 Solicitation Response**

Proc Folder : 575001

Solicitation Description : ADDENDUM 1 4WD RUBBER TIERED WHEEL LOADER W/BUCKET (7019EC15)

Proc Type : Central Master Agreement

Date issued	Solicitation Closes	Solicitation Response	Version
	2019-07-25 13:30:00	SR 0803 ESR07251900000000371	1

VENDOR
000000198312 RISH EQUIPMENT COMPANY

Solicitation Number: CRFQ 0803 DOT1900000125

Total Bid : \$10,178,950.00 **Response Date:** 2019-07-25 **Response Time:** 13:29:07

Comments:

FOR INFORMATION CONTACT THE BUYER
 Crystal G Hustead
 (304) 558-2402
 crystal.g.hustead@wv.gov

Signature on File	FEIN #	DATE
--------------------------	---------------	-------------

All offers subject to all terms and conditions contained in this solicitation

Line	Comm Ln Desc	Qty	Unit Issue	Unit Price	Ln Total Or Contract Amount
1	4WD RUBBER TIRED WHEEL LOADER W/BUCKET	50.00000	EA	\$181,093.000000	\$9,054,650.00

Comm Code	Manufacturer	Specification	Model #
22101501			

Extended Description : 4WD RUBBER TIRED WHEEL LOADER WITH BUCKET

Line	Comm Ln Desc	Qty	Unit Issue	Unit Price	Ln Total Or Contract Amount
2	OPTIONAL: LAND CLEARING RAKE	50.00000	EA	\$12,533.000000	\$626,650.00

Comm Code	Manufacturer	Specification	Model #
22101501			

Extended Description : OPTIONAL: LAND CLEARING RAKE

Line	Comm Ln Desc	Qty	Unit Issue	Unit Price	Ln Total Or Contract Amount
3	OPTIONAL: LOG AND LUMBER FORKS	50.00000	EA	\$9,953.000000	\$497,650.00

Comm Code	Manufacturer	Specification	Model #
22101501			

Extended Description : OPTIONAL: LOG AND LUMBER FORKS



Purchasing Division
2019 Washington Street East
Post Office Box 50130
Charleston, WV 25305-0130

State of West Virginia
Request for Quotation
13 - Equipment

Proc Folder: 575001

Doc Description: 4WD RUBBER TIRED WHEEL LOADER W/BUCKET (7019EC15)

Proc Type: Central Master Agreement

Date Issued	Solicitation Closes	Solicitation No	Version
2019-06-04	2019-07-25 13:30:00	CRFQ 0803 DOT1900000125	1

BID RECEIVING LOCATION

BID CLERK
DEPARTMENT OF ADMINISTRATION
PURCHASING DIVISION
2019 WASHINGTON ST E
CHARLESTON WV 25305
US

VENDOR

Vendor Name, Address and Telephone Number:

Rish Equipment Co.
100 Hellport loop
Bridgetown, WV 26330
304-842-3511 ext 6518

FOR INFORMATION CONTACT THE BUYER

Crystal G Husted
(304) 558-2402
crystal.g.husted@wv.gov

Signature X

FEIN # 54-1390608

DATE 7/25/19

All offers subject to all terms and conditions contained in this solicitation

ADDITIONAL INFORMATION:

THE STATE OF WEST VIRGINIA PURCHASING DIVISION FOR THE AGENCY, WEST VIRGINIA DIVISION OF HIGHWAYS, IS SOLICITING BIDS TO ESTABLISH AN OPEN-END CONTRACT FOR A FOUR-WHEEL DRIVE RUBBER-TIRED WHEEL LOADER WITH BUCKET PER THE ATTACHED DOCUMENTS.

INVOICE TO:		SHIP TO:	
DIVISION OF HIGHWAYS EQUIPMENT DIVISION RT 33 83 BRUSHY ROAD CROSSING, PO BOX 610 BUCKHANNON WV26201 US		DIVISION OF HIGHWAYS EQUIPMENT DIVISION 83 BRUSHY FORK RD CROSSING BUCKHANNON WV 26201 US	

Line	Comm Ln Desc	Qty	Unit Issue	Unit Price	Total Price
1	4WD RUBBER TIRED WHEEL LOADER W/BUCKET	50.00000	EA		

Comm Code	Manufacturer	Specification	Model #
22101501			

Extended Description :

4WD RUBBER TIRED WHEEL LOADER WITH BUCKET

INVOICE TO:		SHIP TO:	
DIVISION OF HIGHWAYS EQUIPMENT DIVISION RT 33 83 BRUSHY ROAD CROSSING, PO BOX 610 BUCKHANNON WV26201 US		DIVISION OF HIGHWAYS EQUIPMENT DIVISION 83 BRUSHY FORK RD CROSSING BUCKHANNON WV 26201 US	

Line	Comm Ln Desc	Qty	Unit Issue	Unit Price	Total Price
2	OPTIONAL: LAND CLEARING RAKE	50.00000	EA		

Comm Code	Manufacturer	Specification	Model #
22101501			

Extended Description :

OPTIONAL: LAND CLEARING RAKE

INVOICE TO:		SHIP TO:	
DIVISION OF HIGHWAYS EQUIPMENT DIVISION RT 33 83 BRUSHY ROAD CROSSING, PO BOX 610 BUCKHANNON WV26201 US		DIVISION OF HIGHWAYS EQUIPMENT DIVISION 83 BRUSHY FORK RD CROSSING BUCKHANNON WV 26201 US	

Line	Comm Ln Desc	Qty	Unit Issue	Unit Price	Total Price
3	OPTIONAL: LOG AND LUMBER FORKS	50.00000	EA		

Comm Code	Manufacturer	Specification	Model #
22101501			

Extended Description :

OPTIONAL: LOG AND LUMBER FORKS

Line	Event	Event Date
1	MANDATORY PRE-BID MEETING	2019-07-02
2	VENDOR QUESTION DEADLINE	2019-07-09

INSTRUCTIONS TO VENDORS SUBMITTING BIDS

1. REVIEW DOCUMENTS THOROUGHLY: The attached documents contain a solicitation for bids. Please read these instructions and all documents attached in their entirety. These instructions provide critical information about requirements that if overlooked could lead to disqualification of a Vendor's bid. All bids must be submitted in accordance with the provisions contained in these instructions and the Solicitation. Failure to do so may result in disqualification of Vendor's bid.

2. MANDATORY TERMS: The Solicitation may contain mandatory provisions identified by the use of the words "must," "will," and "shall." Failure to comply with a mandatory term in the Solicitation will result in bid disqualification.

3. PREBID MEETING: The item identified below shall apply to this Solicitation.

A pre-bid meeting will not be held prior to bid opening

A **NON-MANDATORY PRE-BID** meeting will be held at the following place and time:

A **MANDATORY PRE-BID** meeting will be held at the following place and time:

Date and Time:
July 2, 2019 at 10:00 AM EST

Location:
WDOH Equipment Division
83 Brushy Fork Road Crossing
Buckhannon, WV 26201

All Vendors submitting a bid must attend the mandatory pre-bid meeting. Failure to attend the mandatory pre-bid meeting shall result in disqualification of the Vendor's bid. No one person attending the pre-bid meeting may represent more than one Vendor.

An attendance sheet provided at the pre-bid meeting shall serve as the official document verifying attendance. The State will not accept any other form of proof or documentation to verify attendance. Any person attending the pre-bid meeting on behalf of a Vendor must list on the attendance sheet his or her name and the name of the Vendor he or she is representing.

Additionally, the person attending the pre-bid meeting should include the Vendor's E-Mail address, phone number, and Fax number on the attendance sheet. It is the Vendor's responsibility to locate the attendance sheet and provide the required information. Failure to complete the attendance sheet as required may result in disqualification of Vendor's bid.

All Vendors should arrive prior to the starting time for the pre-bid. Vendors who arrive after the starting time but prior to the end of the pre-bid will be permitted to sign in, but are charged with knowing all matters discussed at the pre-bid.

Questions submitted at least five business days prior to a scheduled pre-bid will be discussed at the pre-bid meeting if possible. Any discussions or answers to questions at the pre-bid meeting are preliminary in nature and are non-binding. Official and binding answers to questions will be published in a written addendum to the Solicitation prior to bid opening.

4. VENDOR QUESTION DEADLINE: Vendors may submit questions relating to this Solicitation to the Purchasing Division. Questions must be submitted in writing. All questions must be submitted on or before the date listed below and to the address listed below in order to be considered. A written response will be published in a Solicitation addendum if a response is possible and appropriate. Non-written discussions, conversations, or questions and answers regarding this Solicitation are preliminary in nature and are nonbinding.

Submitted e-mails should have solicitation number in the subject line.

Question Submission Deadline: July 9, 2019 at 10:00 AM EST

Submit Questions to: Crystal Hustead
2019 Washington Street, East
Charleston, WV 25305

Fax: (304) 558-4115 (Vendors should not use this fax number for bid submission)

Email: Crystal.G.Hustead@wv.gov

5. VERBAL COMMUNICATION: Any verbal communication between the Vendor and any State personnel is not binding, including verbal communication at the mandatory pre-bid conference. Only information issued in writing and added to the Solicitation by an official written addendum by the Purchasing Division is binding.

6. BID SUBMISSION: All bids must be submitted electronically through wvOASIS or signed and delivered by the Vendor to the Purchasing Division at the address listed below on or before the date and time of the bid opening. Any bid received by the Purchasing Division staff is considered to be in the possession of the Purchasing Division and will not be returned for any reason. The Purchasing Division will not accept bids, modification of bids, or addendum acknowledgment forms via e-mail. Acceptable delivery methods include electronic submission via wvOASIS, hand delivery, delivery by courier, or facsimile.

The bid delivery address is:
Department of Administration, Purchasing Division
2019 Washington Street East
Charleston, WV 25305-0130

A bid that is not submitted electronically through wvOASIS should contain the information listed below on the face of the envelope or the bid may be rejected by the Purchasing Division.:

SEALED BID:

BUYER: Crystal Hustead
SOLICITATION NO.: CRFQ DOT1900000125
BID OPENING DATE: July 25, 2019
BID OPENING TIME: 1:30 PM EST
FAX NUMBER: 304-558-3970

The Purchasing Division may prohibit the submission of bids electronically through wvOASIS at its sole discretion. Such a prohibition will be contained and communicated in the wvOASIS system resulting in the Vendor's inability to submit bids through wvOASIS. Submission of a response to an Expression or Interest or Request for Proposal is not permitted in wvOASIS.

For Request For Proposal ("RFP") Responses Only: In the event that Vendor is responding to a request for proposal, the Vendor shall submit one original technical and one original cost proposal plus n/a convenience copies of each to the Purchasing Division at the address shown above. Additionally, the Vendor should identify the bid type as either a technical or cost proposal on the face of each bid envelope submitted in response to a request for proposal as follows:

BID TYPE: (This only applies to CRFP)

- Technical
 Cost

7. BID OPENING: Bids submitted in response to this Solicitation will be opened at the location identified below on the date and time listed below. Delivery of a bid after the bid opening date and time will result in bid disqualification. For purposes of this Solicitation, a bid is considered delivered when confirmation of delivery is provided by wvOASIS (in the case of electronic submission) or when the bid is time stamped by the official Purchasing Division time clock (in the case of hand delivery).

Bid Opening Date and Time: July 25, 2019 at 1:30 PM EST

Bid Opening Location: Department of Administration, Purchasing Division
2019 Washington Street East
Charleston, WV 25305-0130

8. ADDENDUM ACKNOWLEDGEMENT: Changes or revisions to this Solicitation will be made by an official written addendum issued by the Purchasing Division. Vendor should acknowledge receipt of all addenda issued with this Solicitation by completing an Addendum Acknowledgment Form, a copy of which is included herewith. Failure to acknowledge addenda may result in bid disqualification. The addendum acknowledgement should be submitted with the bid to expedite document processing.

9. BID FORMATTING: Vendor should type or electronically enter the information onto its bid to prevent errors in the evaluation. Failure to type or electronically enter the information may result in bid disqualification.

10. ALTERNATE MODEL OR BRAND: Unless the box below is checked, any model, brand, or specification listed in this Solicitation establishes the acceptable level of quality only and is not intended to reflect a preference for, or in any way favor, a particular brand or vendor. Vendors may bid alternates to a listed model or brand provided that the alternate is at least equal to the model or brand and complies with the required specifications. The equality of any alternate being bid shall be determined by the State at its sole discretion. Any Vendor bidding an alternate model or brand should clearly identify the alternate items in its bid and should include manufacturer's specifications, industry literature, and/or any other relevant documentation demonstrating the equality of the alternate items. Failure to provide information for alternate items may be grounds for rejection of a Vendor's bid.

This Solicitation is based upon a standardized commodity established under W. Va. Code § 5A-3-61. Vendors are expected to bid the standardized commodity identified. Failure to bid the standardized commodity will result in your firm's bid being rejected.

11. EXCEPTIONS AND CLARIFICATIONS: The Solicitation contains the specifications that shall form the basis of a contractual agreement. Vendor shall clearly mark any exceptions, clarifications, or other proposed modifications in its bid. Exceptions to, clarifications of, or modifications of a requirement or term and condition of the Solicitation may result in bid disqualification.

12. COMMUNICATION LIMITATIONS: In accordance with West Virginia Code of State Rules §148-1-6.6, communication with the State of West Virginia or any of its employees regarding this Solicitation during the solicitation, bid, evaluation or award periods, except through the Purchasing Division, is strictly prohibited without prior Purchasing Division approval. Purchasing Division approval for such communication is implied for all agency delegated and exempt purchases.

13. REGISTRATION: Prior to Contract award, the apparent successful Vendor must be properly registered with the West Virginia Purchasing Division and must have paid the \$125 fee, if applicable.

14. UNIT PRICE: Unit prices shall prevail in cases of a discrepancy in the Vendor's bid.

15. PREFERENCE: Vendor Preference may be requested in purchases of motor vehicles or construction and maintenance equipment and machinery used in highway and other infrastructure projects. Any request for preference must be submitted in writing with the bid, must specifically identify the preference requested with reference to the applicable subsection of West Virginia Code § 5A-3-37, and should include with the bid any information necessary to evaluate and confirm the applicability of the requested preference. A request form to help facilitate the request can be found at:

<http://www.state.wv.us/admin/purchase/vrc/Venpref.pdf>.

15A. RECIPROCAL PREFERENCE: The State of West Virginia applies a reciprocal preference to all solicitations for commodities and printing in accordance with W. Va. Code § 5A-3-37(b). In effect, non-resident vendors receiving a preference in their home states, will see that same preference granted to West Virginia resident vendors bidding against them in West Virginia. A request form to help facilitate the request can be found at:

<http://www.state.wv.us/admin/purchase/vrc/Venpref.pdf>.

16. SMALL, WOMEN-OWNED, OR MINORITY-OWNED BUSINESSES: For any solicitations publicly advertised for bid, in accordance with West Virginia Code §5A-3-37(a)(7) and W. Va. CSR § 148-22-9, any non-resident vendor certified as a small, women-owned, or minority-owned business under W. Va. CSR § 148-22-9 shall be provided the same preference made available to any resident vendor. Any non-resident small, women-owned, or minority-owned business must identify itself as such in writing, must submit that writing to the Purchasing Division with its bid, and must be properly certified under W. Va. CSR § 148-22-9 prior to contract award to receive the preferences made available to resident vendors. Preference for a non-resident small, women-owned, or minority owned business shall be applied in accordance with W. Va. CSR § 148-22-9.

17. WAIVER OF MINOR IRREGULARITIES: The Director reserves the right to waive minor irregularities in bids or specifications in accordance with West Virginia Code of State Rules § 148-1-4.6.

18. ELECTRONIC FILE ACCESS RESTRICTIONS: Vendor must ensure that its submission in wvOASIS can be accessed and viewed by the Purchasing Division staff immediately upon bid opening. The Purchasing Division will consider any file that cannot be immediately accessed and viewed at the time of the bid opening (such as, encrypted files, password protected files, or incompatible files) to be blank or incomplete as context requires, and are therefore unacceptable. A vendor will not be permitted to unencrypt files, remove password protections, or resubmit documents after bid opening to make a file viewable if those documents are required with the bid. A Vendor may be required to provide document passwords or remove access restrictions to allow the Purchasing Division to print or electronically save documents provided that those documents are viewable by the Purchasing Division prior to obtaining the password or removing the access restriction.

19. NON-RESPONSIBLE: The Purchasing Division Director reserves the right to reject the bid of any vendor as Non-Responsible in accordance with W. Va. Code of State Rules § 148-1-5.3, when the Director determines that the vendor submitting the bid does not have the capability to fully perform, or lacks the integrity and reliability to assure good-faith performance.”

20. ACCEPTANCE/REJECTION: The State may accept or reject any bid in whole, or in part in accordance with W. Va. Code of State Rules § 148-1-4.5. and § 148-1-6.4.b.”

21. YOUR SUBMISSION IS A PUBLIC DOCUMENT: Vendor’s entire response to the Solicitation and the resulting Contract are public documents. As public documents, they will be disclosed to the public following the bid/proposal opening or award of the contract, as required by the competitive bidding laws of West Virginia Code §§ 5A-3-1 et seq., 5-22-1 et seq., and 5G-1-1 et seq. and the Freedom of Information Act West Virginia Code §§ 29B-1-1 et seq.

DO NOT SUBMIT MATERIAL YOU CONSIDER TO BE CONFIDENTIAL, A TRADE SECRET, OR OTHERWISE NOT SUBJECT TO PUBLIC DISCLOSURE.

Submission of any bid, proposal, or other document to the Purchasing Division constitutes your explicit consent to the subsequent public disclosure of the bid, proposal, or document. The Purchasing Division will disclose any document labeled “confidential,” “proprietary,” “trade secret,” “private,” or labeled with any other claim against public disclosure of the documents, to include any “trade secrets” as defined by West Virginia Code § 47-22-1 et seq. All submissions are subject to public disclosure without notice.

22. INTERESTED PARTY DISCLOSURE: West Virginia Code § 6D-1-2 requires that the vendor submit to the Purchasing Division a disclosure of interested parties to the contract for all contracts with an actual or estimated value of at least \$1 Million. That disclosure must occur on the form prescribed and approved by the WV Ethics Commission prior to contract award. A copy of that form is included with this solicitation or can be obtained from the WV Ethics Commission. This requirement does not apply to publicly traded companies listed on a national or international stock exchange. A more detailed definition of interested parties can be obtained from the form referenced above.

23. WITH THE BID REQUIREMENTS: In instances where these specifications require documentation or other information with the bid, and a vendor fails to provide it with the bid, the Director of the Purchasing Division reserves the right to request those items after bid opening and prior to contract award pursuant to the authority to waive minor irregularities in bids or specifications under W. Va. CSR § 148-1-4.6. This authority does not apply to instances where state law mandates receipt with the bid.

GENERAL TERMS AND CONDITIONS:

1. CONTRACTUAL AGREEMENT: Issuance of a Award Document signed by the Purchasing Division Director, or his designee, and approved as to form by the Attorney General's office constitutes acceptance of this Contract made by and between the State of West Virginia and the Vendor. Vendor's signature on its bid signifies Vendor's agreement to be bound by and accept the terms and conditions contained in this Contract.

2. DEFINITIONS: As used in this Solicitation/Contract, the following terms shall have the meanings attributed to them below. Additional definitions may be found in the specifications included with this Solicitation/Contract.

2.1. "Agency" or "Agencies" means the agency, board, commission, or other entity of the State of West Virginia that is identified on the first page of the Solicitation or any other public entity seeking to procure goods or services under this Contract.

2.2. "Bid" or "Proposal" means the vendors submitted response to this solicitation.

2.3. "Contract" means the binding agreement that is entered into between the State and the Vendor to provide the goods or services requested in the Solicitation.

2.4. "Director" means the Director of the West Virginia Department of Administration, Purchasing Division.

2.5. "Purchasing Division" means the West Virginia Department of Administration, Purchasing Division.

2.6. "Award Document" means the document signed by the Agency and the Purchasing Division, and approved as to form by the Attorney General, that identifies the Vendor as the contract holder.

2.7. "Solicitation" means the official notice of an opportunity to supply the State with goods or services that is published by the Purchasing Division.

2.8. "State" means the State of West Virginia and/or any of its agencies, commissions, boards, etc. as context requires.

2.9. "Vendor" or "Vendors" means any entity submitting a bid in response to the Solicitation, the entity that has been selected as the lowest responsible bidder, or the entity that has been awarded the Contract as context requires.

3. CONTRACT TERM; RENEWAL; EXTENSION: The term of this Contract shall be determined in accordance with the category that has been identified as applicable to this Contract below:

Term Contract

Initial Contract Term: **Initial Contract Term:** This Contract becomes effective on _____ Award and extends for a period of One (1) year(s).

Renewal Term: This Contract may be renewed upon the mutual written consent of the Agency, and the Vendor, with approval of the Purchasing Division and the Attorney General's office (Attorney General approval is as to form only). Any request for renewal should be delivered to the Agency and then submitted to the Purchasing Division thirty (30) days prior to the expiration date of the initial contract term or appropriate renewal term. A Contract renewal shall be in accordance with the terms and conditions of the original contract. Unless otherwise specified below, renewal of this Contract is limited to Three (3) successive one (1) year periods or multiple renewal periods of less than one year, provided that the multiple renewal periods do not exceed the total number of months available in all renewal years combined. Automatic renewal of this Contract is prohibited. Renewals must be approved by the Vendor, Agency, Purchasing Division and Attorney General's office (Attorney General approval is as to form only)

Alternate Renewal Term – This contract may be renewed for _____ successive _____ year periods or shorter periods provided that they do not exceed the total number of months contained in all available renewals. Automatic renewal of this Contract is prohibited. Renewals must be approved by the Vendor, Agency, Purchasing Division and Attorney General's office (Attorney General approval is as to form only)

Delivery Order Limitations: In the event that this contract permits delivery orders, a delivery order may only be issued during the time this Contract is in effect. Any delivery order issued within one year of the expiration of this Contract shall be effective for one year from the date the delivery order is issued. No delivery order may be extended beyond one year after this Contract has expired.

Fixed Period Contract: This Contract becomes effective upon Vendor's receipt of the notice to proceed and must be completed within _____ days.

Fixed Period Contract with Renewals: This Contract becomes effective upon Vendor's receipt of the notice to proceed and part of the Contract more fully described in the attached specifications must be completed within _____ days. Upon completion of the work covered by the preceding sentence, the vendor agrees that maintenance, monitoring, or warranty services will be provided for _____ year(s) thereafter.

One Time Purchase: The term of this Contract shall run from the issuance of the Award Document until all of the goods contracted for have been delivered, but in no event will this Contract extend for more than one fiscal year.

Other: See attached.

4. NOTICE TO PROCEED: Vendor shall begin performance of this Contract immediately upon receiving notice to proceed unless otherwise instructed by the Agency. Unless otherwise specified, the fully executed Award Document will be considered notice to proceed.

5. QUANTITIES: The quantities required under this Contract shall be determined in accordance with the category that has been identified as applicable to this Contract below.

Open End Contract: Quantities listed in this Solicitation are approximations only, based on estimates supplied by the Agency. It is understood and agreed that the Contract shall cover the quantities actually ordered for delivery during the term of the Contract, whether more or less than the quantities shown.

Service: The scope of the service to be provided will be more clearly defined in the specifications included herewith.

Combined Service and Goods: The scope of the service and deliverable goods to be provided will be more clearly defined in the specifications included herewith.

One Time Purchase: This Contract is for the purchase of a set quantity of goods that are identified in the specifications included herewith. Once those items have been delivered, no additional goods may be procured under this Contract without an appropriate change order approved by the Vendor, Agency, Purchasing Division, and Attorney General's office.

6. EMERGENCY PURCHASES: The Purchasing Division Director may authorize the Agency to purchase goods or services in the open market that Vendor would otherwise provide under this Contract if those goods or services are for immediate or expedited delivery in an emergency. Emergencies shall include, but are not limited to, delays in transportation or an unanticipated increase in the volume of work. An emergency purchase in the open market, approved by the Purchasing Division Director, shall not constitute of breach of this Contract and shall not entitle the Vendor to any form of compensation or damages. This provision does not excuse the State from fulfilling its obligations under a One Time Purchase contract.

7. REQUIRED DOCUMENTS: All of the items checked below must be provided to the Purchasing Division by the Vendor as specified below.

BID BOND (Construction Only): Pursuant to the requirements contained in W. Va. Code § 5-22-1(c), All Vendors submitting a bid on a construction project shall furnish a valid bid bond in the amount of five percent (5%) of the total amount of the bid protecting the State of West Virginia. The bid bond must be submitted with the bid.

PERFORMANCE BOND: The apparent successful Vendor shall provide a performance bond in the amount of 100% of the contract. The performance bond must be received by the Purchasing Division prior to Contract award.

LABOR/MATERIAL PAYMENT BOND: The apparent successful Vendor shall provide a labor/material payment bond in the amount of 100% of the Contract value. The labor/material payment bond must be delivered to the Purchasing Division prior to Contract award.

In lieu of the Bid Bond, Performance Bond, and Labor/Material Payment Bond, the Vendor may provide certified checks, cashier's checks, or irrevocable letters of credit. Any certified check, cashier's check, or irrevocable letter of credit provided in lieu of a bond must be of the same amount and delivered on the same schedule as the bond it replaces. A letter of credit submitted in lieu of a performance and labor/material payment bond will only be allowed for projects under \$100,000. Personal or business checks are not acceptable. Notwithstanding the foregoing, West Virginia Code § 5-22-1 (d) mandates that a vendor provide a performance and labor/material payment bond for construction projects. Accordingly, substitutions for the performance and labor/material payment bonds for construction projects is not permitted.

MAINTENANCE BOND: The apparent successful Vendor shall provide a two (2) year maintenance bond covering the roofing system. The maintenance bond must be issued and delivered to the Purchasing Division prior to Contract award.

LICENSE(S) / CERTIFICATIONS / PERMITS: In addition to anything required under the Section of the General Terms and Conditions entitled Licensing, the apparent successful Vendor shall furnish proof of the following licenses, certifications, and/or permits prior to Contract award, in a form acceptable to the Purchasing Division.

The apparent successful Vendor shall also furnish proof of any additional licenses or certifications contained in the specifications prior to Contract award regardless of whether or not that requirement is listed above.

8. INSURANCE: The apparent successful Vendor shall furnish proof of the insurance identified by a checkmark below and must include the State as an additional insured on each policy prior to Contract award. The insurance coverages identified below must be maintained throughout the life of this contract. Thirty (30) days prior to the expiration of the insurance policies, Vendor shall provide the Agency with proof that the insurance mandated herein has been continued. Vendor must also provide Agency with immediate notice of any changes in its insurance policies, including but not limited to, policy cancelation, policy reduction, or change in insurers. The apparent successful Vendor shall also furnish proof of any additional insurance requirements contained in the specifications prior to Contract award regardless of whether or not that insurance requirement is listed in this section.

Vendor must maintain:

Commercial General Liability Insurance in at least an amount of: \$1,000,000.00-See below per occurrence.

Automobile Liability Insurance in at least an amount of: \$1,000,000.00 per occurrence.

Professional/Malpractice/Errors and Omission Insurance in at least an amount of: _____ per occurrence.

Commercial Crime and Third Party Fidelity Insurance in an amount of: _____ per occurrence.

Cyber Liability Insurance in an amount of: _____ per occurrence.

Builders Risk Insurance in an amount equal to 100% of the amount of the Contract.

Pollution Insurance in an amount of: _____ per occurrence.

Aircraft Liability in an amount of: _____ per occurrence.

****Please make insurance certificate to read as follows:**
State of WV, 1900 Kanawha Blvd E, Bldg 5, Charleston, WV 25305

State of WV must be listed as additional insured.

Notwithstanding anything contained in this section to the contrary, the Director of the Purchasing Division reserves the right to waive the requirement that the State be named as an additional insured on one or more of the Vendor's insurance policies if the Director finds that doing so is in the State's best interest.

9. WORKERS' COMPENSATION INSURANCE: The apparent successful Vendor shall comply with laws relating to workers compensation, shall maintain workers' compensation insurance when required, and shall furnish proof of workers' compensation insurance upon request.

10. [Reserved]

11. LIQUIDATED DAMAGES: This clause shall in no way be considered exclusive and shall not limit the State or Agency's right to pursue any other available remedy. Vendor shall pay liquidated damages in the amount specified below or as described in the specifications:

_____ for _____

Liquidated Damages Contained in the Specifications

12. ACCEPTANCE: Vendor's signature on its bid, or on the certification and signature page, constitutes an offer to the State that cannot be unilaterally withdrawn, signifies that the product or service proposed by vendor meets the mandatory requirements contained in the Solicitation for that product or service, unless otherwise indicated, and signifies acceptance of the terms and conditions contained in the Solicitation unless otherwise indicated.

13. PRICING: The pricing set forth herein is firm for the life of the Contract, unless specified elsewhere within this Solicitation/Contract by the State. A Vendor's inclusion of price adjustment provisions in its bid, without an express authorization from the State in the Solicitation to do so, may result in bid disqualification. Notwithstanding the foregoing, Vendor must extend any publicly advertised sale price to the State and invoice at the lower of the contract price or the publicly advertised sale price.

14. PAYMENT IN ARREARS: Payment in advance is prohibited under this Contract. Payment may only be made after the delivery and acceptance of goods or services. The Vendor shall submit invoices, in arrears.

15. PAYMENT METHODS: Vendor must accept payment by electronic funds transfer and P-Card. (The State of West Virginia's Purchasing Card program, administered under contract by a banking institution, processes payment for goods and services through state designated credit cards.)

16. TAXES: The Vendor shall pay any applicable sales, use, personal property or any other taxes arising out of this Contract and the transactions contemplated thereby. The State of West Virginia is exempt from federal and state taxes and will not pay or reimburse such taxes.

17. ADDITIONAL FEES: Vendor is not permitted to charge additional fees or assess additional charges that were not either expressly provided for in the solicitation published by the State of West Virginia or included in the unit price or lump sum bid amount that Vendor is required by the solicitation to provide. Including such fees or charges as notes to the solicitation may result in rejection of vendor's bid. Requesting such fees or charges be paid after the contract has been awarded may result in cancellation of the contract.

18. FUNDING: This Contract shall continue for the term stated herein, contingent upon funds being appropriated by the Legislature or otherwise being made available. In the event funds are not appropriated or otherwise made available, this Contract becomes void and of no effect beginning on July 1 of the fiscal year for which funding has not been appropriated or otherwise made available.

19. CANCELLATION: The Purchasing Division Director reserves the right to cancel this Contract immediately upon written notice to the vendor if the materials or workmanship supplied do not conform to the specifications contained in the Contract. The Purchasing Division Director may also cancel any purchase or Contract upon 30 days written notice to the Vendor in accordance with West Virginia Code of State Rules § 148-1-5.2.b.

20. TIME: Time is of the essence with regard to all matters of time and performance in this Contract.

21. APPLICABLE LAW: This Contract is governed by and interpreted under West Virginia law without giving effect to its choice of law principles. Any information provided in specification manuals, or any other source, verbal or written, which contradicts or violates the West Virginia Constitution, West Virginia Code or West Virginia Code of State Rules is void and of no effect.

22. COMPLIANCE WITH LAWS: Vendor shall comply with all applicable federal, state, and local laws, regulations and ordinances. By submitting a bid, Vendor acknowledges that it has reviewed, understands, and will comply with all applicable laws, regulations, and ordinances.

SUBCONTRACTOR COMPLIANCE: Vendor shall notify all subcontractors providing commodities or services related to this Contract that as subcontractors, they too are required to comply with all applicable laws, regulations, and ordinances. Notification under this provision must occur prior to the performance of any work under the contract by the subcontractor.

23. ARBITRATION: Any references made to arbitration contained in this Contract, Vendor's bid, or in any American Institute of Architects documents pertaining to this Contract are hereby deleted, void, and of no effect.

24. MODIFICATIONS: This writing is the parties' final expression of intent. Notwithstanding anything contained in this Contract to the contrary no modification of this Contract shall be binding without mutual written consent of the Agency, and the Vendor, with approval of the Purchasing Division and the Attorney General's office (Attorney General approval is as to form only). Any change to existing contracts that adds work or changes contract cost, and were not included in the original contract, must be approved by the Purchasing Division and the Attorney General's Office (as to form) prior to the implementation of the change or commencement of work affected by the change.

25. WAIVER: The failure of either party to insist upon a strict performance of any of the terms or provision of this Contract, or to exercise any option, right, or remedy herein contained, shall not be construed as a waiver or a relinquishment for the future of such term, provision, option, right, or remedy, but the same shall continue in full force and effect. Any waiver must be expressly stated in writing and signed by the waiving party.

26. SUBSEQUENT FORMS: The terms and conditions contained in this Contract shall supersede any and all subsequent terms and conditions which may appear on any form documents submitted by Vendor to the Agency or Purchasing Division such as price lists, order forms, invoices, sales agreements, or maintenance agreements, and includes internet websites or other electronic documents. Acceptance or use of Vendor's forms does not constitute acceptance of the terms and conditions contained thereon.

27. ASSIGNMENT: Neither this Contract nor any monies due, or to become due hereunder, may be assigned by the Vendor without the express written consent of the Agency, the Purchasing Division, the Attorney General's office (as to form only), and any other government agency or office that may be required to approve such assignments.

28. WARRANTY: The Vendor expressly warrants that the goods and/or services covered by this Contract will: (a) conform to the specifications, drawings, samples, or other description furnished or specified by the Agency; (b) be merchantable and fit for the purpose intended; and (c) be free from defect in material and workmanship.

29. STATE EMPLOYEES: State employees are not permitted to utilize this Contract for personal use and the Vendor is prohibited from permitting or facilitating the same.

30. PRIVACY, SECURITY, AND CONFIDENTIALITY: The Vendor agrees that it will not disclose to anyone, directly or indirectly, any such personally identifiable information or other confidential information gained from the Agency, unless the individual who is the subject of the information consents to the disclosure in writing or the disclosure is made pursuant to the Agency's policies, procedures, and rules. Vendor further agrees to comply with the Confidentiality Policies and Information Security Accountability Requirements, set forth in <http://www.state.wv.us/admin/purchase/privacy/default.html>.

31. YOUR SUBMISSION IS A PUBLIC DOCUMENT: Vendor's entire response to the Solicitation and the resulting Contract are public documents. As public documents, they will be disclosed to the public following the bid/proposal opening or award of the contract, as required by the competitive bidding laws of West Virginia Code §§ 5A-3-1 et seq., 5-22-1 et seq., and 5G-1-1 et seq. and the Freedom of Information Act West Virginia Code §§ 29B-1-1 et seq.

DO NOT SUBMIT MATERIAL YOU CONSIDER TO BE CONFIDENTIAL, A TRADE SECRET, OR OTHERWISE NOT SUBJECT TO PUBLIC DISCLOSURE.

Submission of any bid, proposal, or other document to the Purchasing Division constitutes your explicit consent to the subsequent public disclosure of the bid, proposal, or document. The Purchasing Division will disclose any document labeled "confidential," "proprietary," "trade secret," "private," or labeled with any other claim against public disclosure of the documents, to include any "trade secrets" as defined by West Virginia Code § 47-22-1 et seq. All submissions are subject to public disclosure without notice.

32. LICENSING: In accordance with West Virginia Code of State Rules § 148-1-6.1.e, Vendor must be licensed and in good standing in accordance with any and all state and local laws and requirements by any state or local agency of West Virginia, including, but not limited to, the West Virginia Secretary of State's Office, the West Virginia Tax Department, West Virginia Insurance Commission, or any other state agency or political subdivision. Obligations related to political subdivisions may include, but are not limited to, business licensing, business and occupation taxes, inspection compliance, permitting, etc. Upon request, the Vendor must provide all necessary releases to obtain information to enable the Purchasing Division Director or the Agency to verify that the Vendor is licensed and in good standing with the above entities.

SUBCONTRACTOR COMPLIANCE: Vendor shall notify all subcontractors providing commodities or services related to this Contract that as subcontractors, they too are required to be licensed, in good standing, and up-to-date on all state and local obligations as described in this section. Obligations related to political subdivisions may include, but are not limited to, business licensing, business and occupation taxes, inspection compliance, permitting, etc. Notification under this provision must occur prior to the performance of any work under the contract by the subcontractor.

33. ANTITRUST: In submitting a bid to, signing a contract with, or accepting a Award Document from any agency of the State of West Virginia, the Vendor agrees to convey, sell, assign, or transfer to the State of West Virginia all rights, title, and interest in and to all causes of action it may now or hereafter acquire under the antitrust laws of the United States and the State of West Virginia for price fixing and/or unreasonable restraints of trade relating to the particular commodities or services purchased or acquired by the State of West Virginia. Such assignment shall be made and become effective at the time the purchasing agency tenders the initial payment to Vendor.

34. VENDOR CERTIFICATIONS: By signing its bid or entering into this Contract, Vendor certifies (1) that its bid or offer was made without prior understanding, agreement, or connection with any corporation, firm, limited liability company, partnership, person or entity submitting a bid or offer for the same material, supplies, equipment or services; (2) that its bid or offer is in all respects fair and without collusion or fraud; (3) that this Contract is accepted or entered into without any prior understanding, agreement, or connection to any other entity that could be considered a violation of law; and (4) that it has reviewed this Solicitation in its entirety; understands the requirements, terms and conditions, and other information contained herein.

Vendor's signature on its bid or offer also affirms that neither it nor its representatives have any interest, nor shall acquire any interest, direct or indirect, which would compromise the performance of its services hereunder. Any such interests shall be promptly presented in detail to the Agency. The individual signing this bid or offer on behalf of Vendor certifies that he or she is authorized by the Vendor to execute this bid or offer or any documents related thereto on Vendor's behalf; that he or she is authorized to bind the Vendor in a contractual relationship; and that, to the best of his or her knowledge, the Vendor has properly registered with any State agency that may require registration.

35. VENDOR RELATIONSHIP: The relationship of the Vendor to the State shall be that of an independent contractor and no principal-agent relationship or employer-employee relationship is contemplated or created by this Contract. The Vendor as an independent contractor is solely liable for the acts and omissions of its employees and agents. Vendor shall be responsible for selecting, supervising, and compensating any and all individuals employed pursuant to the terms of this Solicitation and resulting contract. Neither the Vendor, nor any employees or subcontractors of the Vendor, shall be deemed to be employees of the State for any purpose whatsoever. Vendor shall be exclusively responsible for payment of employees and contractors for all wages and salaries, taxes, withholding payments, penalties, fees, fringe benefits, professional liability insurance premiums, contributions to insurance and pension, or other deferred compensation plans, including but not limited to, Workers' Compensation and Social Security obligations, licensing fees, etc. and the filing of all necessary documents, forms, and returns pertinent to all of the foregoing.

Vendor shall hold harmless the State, and shall provide the State and Agency with a defense against any and all claims including, but not limited to, the foregoing payments, withholdings, contributions, taxes, Social Security taxes, and employer income tax returns.

36. INDEMNIFICATION: The Vendor agrees to indemnify, defend, and hold harmless the State and the Agency, their officers, and employees from and against: (1) Any claims or losses for services rendered by any subcontractor, person, or firm performing or supplying services, materials, or supplies in connection with the performance of the Contract; (2) Any claims or losses resulting to any person or entity injured or damaged by the Vendor, its officers, employees, or subcontractors by the publication, translation, reproduction, delivery, performance, use, or disposition of any data used under the Contract in a manner not authorized by the Contract, or by Federal or State statutes or regulations; and (3) Any failure of the Vendor, its officers, employees, or subcontractors to observe State and Federal laws including, but not limited to, labor and wage and hour laws.

37. PURCHASING AFFIDAVIT: In accordance with West Virginia Code §§ 5A-3-10a and 5-22-1(i), the State is prohibited from awarding a contract to any bidder that owes a debt to the State or a political subdivision of the State, Vendors are required to sign, notarize, and submit the Purchasing Affidavit to the Purchasing Division affirming under oath that it is not in default on any monetary obligation owed to the state or a political subdivision of the state.

38. ADDITIONAL AGENCY AND LOCAL GOVERNMENT USE: This Contract may be utilized by other agencies, spending units, and political subdivisions of the State of West Virginia; county, municipal, and other local government bodies; and school districts ("Other Government Entities"), provided that both the Other Government Entity and the Vendor agree. Any extension of this Contract to the aforementioned Other Government Entities must be on the same prices, terms, and conditions as those offered and agreed to in this Contract, provided that such extension is in compliance with the applicable laws, rules, and ordinances of the Other Government Entity. A refusal to extend this Contract to the Other Government Entities shall not impact or influence the award of this Contract in any manner.

39. CONFLICT OF INTEREST: Vendor, its officers or members or employees, shall not presently have or acquire an interest, direct or indirect, which would conflict with or compromise the performance of its obligations hereunder. Vendor shall periodically inquire of its officers, members and employees to ensure that a conflict of interest does not arise. Any conflict of interest discovered shall be promptly presented in detail to the Agency.

40. REPORTS: Vendor shall provide the Agency and/or the Purchasing Division with the following reports identified by a checked box below:

Such reports as the Agency and/or the Purchasing Division may request. Requested reports may include, but are not limited to, quantities purchased, agencies utilizing the contract, total contract expenditures by agency, etc.

Quarterly reports detailing the total quantity of purchases in units and dollars, along with a listing of purchases by agency. Quarterly reports should be delivered to the Purchasing Division via email at purchasing.requisitions@wv.gov.

41. BACKGROUND CHECK: In accordance with W. Va. Code § 15-2D-3, the Director of the Division of Protective Services shall require any service provider whose employees are regularly employed on the grounds or in the buildings of the Capitol complex or who have access to sensitive or critical information to submit to a fingerprint-based state and federal background inquiry through the state repository. The service provider is responsible for any costs associated with the fingerprint-based state and federal background inquiry.

After the contract for such services has been approved, but before any such employees are permitted to be on the grounds or in the buildings of the Capitol complex or have access to sensitive or critical information, the service provider shall submit a list of all persons who will be physically present and working at the Capitol complex to the Director of the Division of Protective Services for purposes of verifying compliance with this provision. The State reserves the right to prohibit a service provider's employees from accessing sensitive or critical information or to be present at the Capitol complex based upon results addressed from a criminal background check.

Revised 01/24/2019

Service providers should contact the West Virginia Division of Protective Services by phone at (304) 558-9911 for more information.

42. PREFERENCE FOR USE OF DOMESTIC STEEL PRODUCTS: Except when authorized by the Director of the Purchasing Division pursuant to W. Va. Code § 5A-3-56, no contractor may use or supply steel products for a State Contract Project other than those steel products made in the United States. A contractor who uses steel products in violation of this section may be subject to civil penalties pursuant to W. Va. Code § 5A-3-56. As used in this section:

- a. "State Contract Project" means any erection or construction of, or any addition to, alteration of or other improvement to any building or structure, including, but not limited to, roads or highways, or the installation of any heating or cooling or ventilating plants or other equipment, or the supply of and materials for such projects, pursuant to a contract with the State of West Virginia for which bids were solicited on or after June 6, 2001.
- b. "Steel Products" means products rolled, formed, shaped, drawn, extruded, forged, cast, fabricated or otherwise similarly processed, or processed by a combination of two or more or such operations, from steel made by the open heath, basic oxygen, electric furnace, Bessemer or other steel making process. The Purchasing Division Director may, in writing, authorize the use of foreign steel products if:
- c. The cost for each contract item used does not exceed one tenth of one percent (.1%) of the total contract cost or two thousand five hundred dollars (\$2,500.00), whichever is greater. For the purposes of this section, the cost is the value of the steel product as delivered to the project; or
- d. The Director of the Purchasing Division determines that specified steel materials are not produced in the United States in sufficient quantity or otherwise are not reasonably available to meet contract requirements.

43. PREFERENCE FOR USE OF DOMESTIC ALUMINUM, GLASS, AND STEEL: In Accordance with W. Va. Code § 5-19-1 et seq., and W. Va. CSR § 148-10-1 et seq., for every contract or subcontract, subject to the limitations contained herein, for the construction, reconstruction, alteration, repair, improvement or maintenance of public works or for the purchase of any item of machinery or equipment to be used at sites of public works, only domestic aluminum, glass or steel products shall be supplied unless the spending officer determines, in writing, after the receipt of offers or bids, (1) that the cost of domestic aluminum, glass or steel products is unreasonable or inconsistent with the public interest of the State of West Virginia, (2) that domestic aluminum, glass or steel products are not produced in sufficient quantities to meet the contract requirements, or (3) the available domestic aluminum, glass, or steel do not meet the contract specifications. This provision only applies to public works contracts awarded in an amount more than fifty thousand dollars (\$50,000) or public works contracts that require more than ten thousand pounds of steel products.

The cost of domestic aluminum, glass, or steel products may be unreasonable if the cost is more than twenty percent (20%) of the bid or offered price for foreign made aluminum, glass, or steel products. If the domestic aluminum, glass or steel products to be supplied or produced in a

“substantial labor surplus area”, as defined by the United States Department of Labor, the cost of domestic aluminum, glass, or steel products may be unreasonable if the cost is more than thirty percent (30%) of the bid or offered price for foreign made aluminum, glass, or steel products. This preference shall be applied to an item of machinery or equipment, as indicated above, when the item is a single unit of equipment or machinery manufactured primarily of aluminum, glass or steel, is part of a public works contract and has the sole purpose or of being a permanent part of a single public works project. This provision does not apply to equipment or machinery purchased by a spending unit for use by that spending unit and not as part of a single public works project.

All bids and offers including domestic aluminum, glass or steel products that exceed bid or offer prices including foreign aluminum, glass or steel products after application of the preferences provided in this provision may be reduced to a price equal to or lower than the lowest bid or offer price for foreign aluminum, glass or steel products plus the applicable preference. If the reduced bid or offer prices are made in writing and supersede the prior bid or offer prices, all bids or offers, including the reduced bid or offer prices, will be reevaluated in accordance with this rule.

44. INTERESTED PARTY SUPPLEMENTAL DISCLOSURE: W. Va. Code § 6D-1-2 requires that for contracts with an actual or estimated value of at least \$1 million, the vendor must submit to the Agency a supplemental disclosure of interested parties reflecting any new or differing interested parties to the contract, which were not included in the original pre-award interested party disclosure, within 30 days following the completion or termination of the contract. A copy of that form is included with this solicitation or can be obtained from the WV Ethics Commission. This requirement does not apply to publicly traded companies listed on a national or international stock exchange. A more detailed definition of interested parties can be obtained from the form referenced above.

DESIGNATED CONTACT: Vendor appoints the individual identified in this Section as the Contract Administrator and the initial point of contact for matters relating to this Contract.

Miranda Novak, sales coordinator
(Name, Title)
Miranda Novak, sales coordinator
(Printed Name and Title)
100 Heliport Loop Bridgeport WV 26330
(Address)
724-415-7777, 304-842-6126
(Phone Number) / (Fax Number)
mnovalk@rish.com
(email address)

CERTIFICATION AND SIGNATURE: By signing below, or submitting documentation through wvOASIS, I certify that I have reviewed this Solicitation in its entirety; that I understand the requirements, terms and conditions, and other information contained herein; that this bid, offer or proposal constitutes an offer to the State that cannot be unilaterally withdrawn; that the product or service proposed meets the mandatory requirements contained in the Solicitation for that product or service, unless otherwise stated herein; that the Vendor accepts the terms and conditions contained in the Solicitation, unless otherwise stated herein; that I am submitting this bid, offer or proposal for review and consideration; that I am authorized by the vendor to execute and submit this bid, offer, or proposal, or any documents related thereto on vendor's behalf; that I am authorized to bind the vendor in a contractual relationship; and that to the best of my knowledge, the vendor has properly registered with any State agency that may require registration.

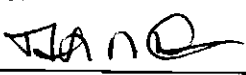
Rish Equipment Co.
(Company)
 Sales Coordinator
(Authorized Signature) (Representative Name, Title)
Miranda M. Novak, Sales Coordinator
(Printed Name and Title of Authorized Representative)
7/25/19
(Date)
724-415-7777 / 304-842-6126
(Phone Number) (Fax Number)

ADDENDUM ACKNOWLEDGEMENT FORM
SOLICITATION NO.: CRFQ DOT1900000125

Instructions: Please acknowledge receipt of all addenda issued with this solicitation by completing this addendum acknowledgment form. Check the box next to each addendum received and sign below. Failure to acknowledge addenda may result in bid disqualification.

Acknowledgment: I hereby acknowledge receipt of the following addenda and have made the necessary revisions to my proposal, plans and/or specification, etc.

Addendum Numbers Received:

(Check the box next to each addendum received)

- | | |
|--|--|
| <input checked="" type="checkbox"/> Addendum No. 1 | <input type="checkbox"/> Addendum No. 6 |
| <input type="checkbox"/> Addendum No. 2 | <input type="checkbox"/> Addendum No. 7 |
| <input type="checkbox"/> Addendum No. 3 | <input type="checkbox"/> Addendum No. 8 |
| <input type="checkbox"/> Addendum No. 4 | <input type="checkbox"/> Addendum No. 9 |
| <input type="checkbox"/> Addendum No. 5 | <input type="checkbox"/> Addendum No. 10 |

I understand that failure to confirm the receipt of addenda may be cause for rejection of this bid. I further understand that any verbal representation made or assumed to be made during any oral discussion held between Vendor's representatives and any state personnel is not binding. Only the information issued in writing and added to the specifications by an official addendum is binding.

Rish Equipment Co.
Company

[Signature]
Authorized Signature

7/25/19
Date

NOTE: This addendum acknowledgment should be submitted with the bid to expedite document processing.

REQUEST FOR QUOTATION
CRFQ DOT1900000125
(Class 353) 4WD Rubber Tired Wheel Loader with Bucket (7019EC15)

SPECIFICATIONS

1. **PURPOSE AND SCOPE:** The West Virginia Purchasing Division is soliciting bids on behalf of West Virginia Division of Highways to establish an open-end contract for a 4 Wheel Drive, Rubber Tired Wheel Loader John Deere with Bucket or equal.

2. **DEFINITIONS:** The terms listed below shall have the meanings assigned to them below. Additional definitions can be found in section 2 of the General Terms and Conditions.
 - 2.1 **“Contract Item” or “Contract Items”** means the list of items identified in Section 3.1 below and on the Pricing Pages.
 - 2.2 **“Pricing Pages”** means the schedule of prices, estimated order quantity, and totals contained in wvOASIS or attached hereto as Exhibit A, and used to evaluate the Solicitation responses.
 - 2.3 **“Solicitation”** means the official notice of an opportunity to supply the State with goods or services that is published by the Purchasing Division.
 - 2.4 **“WVDOH”** means West Virginia Division of Highways.
 - 2.5 **“°”** means degrees.
 - 2.6 **“HP”** means horsepower.
 - 2.7 **“F”** means Fahrenheit.
 - 2.8 **“CCA”** means cold cranking amps.
 - 2.9 **“PSI”** means pounds per square inch.
 - 2.10 **“ROPS”** means rollover protection system.
 - 2.11 **“Class 353”** is for WVDOH internal use only

3. **GENERAL REQUIREMENTS:**
 - 3.1 **Contract Items and Mandatory Requirements:** Vendor shall provide Agency with the Contract Items listed below on an open-end and continuing

REQUEST FOR QUOTATION
CRFQ DOT1900000125
(Class 353) 4WD Rubber Tired Wheel Loader with Bucket (7019EC15)

basis. Contract Items must meet or exceed the mandatory requirements as shown below.

**3.1.1 4 Wheel Drive Rubber Tired Wheel Loader John Deere
with Bucket or equal mandatory requirements.**

- 3.1.1.1 The unit specified herein and offered shall be manufactured on or after January 1, 2020 and will be clearly identified and marked with date of manufacture.
- 3.1.1.2 Unit shall be equipped with manufacturers' vandalism package and all machines keyed alike.
- 3.1.1.3 Operating weight shall be 25,000 pounds' minimum (exclusive of tire ballast). WA200
- 3.1.1.4 Unit shall have a breakout force of 14,600 pounds' minimum.
- 3.1.1.5 Overall length (bucket on ground) shall be 24-foot maximum. 24.5"
- 3.1.1.6 Loader shall have articulated frame with full hydraulic power steering.
- 3.1.1.7 Overall height shall be 10 feet 8 inches to top of cab (maximum). 10' 11"
- 3.1.1.8 Dumping clearance at maximum height and 45-degree dump angle shall be 100-inches' minimum.
- 3.1.1.9 Loader shall be equipped with a hydraulic quick coupler system for interchangeability of attachments, controlled from operator station. (bucket removal to forks or material handler without leaving cab)

REQUEST FOR QUOTATION
CRFQ DOT1900000125
(Class 353) 4WD Rubber Tired Wheel Loader with Bucket (7019EC15)

3.1.3 ENGINE

3.1.3.1 Engine shall be Tier 4 Final

3.1.3.2 Engine shall be a minimum power rating of 120 HP (Horse Power).

3.1.3.3 Engine shall have an engine block heater installed.

3.1.3.4 Engine shall have a cold weather starting system.

3.1.3.5 Engine shall have engine oil cooler.

3.1.3.6 Engine shall have electrical fuel priming pump.

3.1.4 AUTOMATED CHASSIS LUBERCATION SYSTEM

3.1.4.1 Shall have on-board automated grease lubrication system installed by manufacturer.

3.1.5 COOLING SYSTEMS

3.1.5.1 Manufacturer shall provide maximum cooling system available to allow machine to operate at full capability during all seasons with automatic reversing fan drive.

3.1.5.2 Cooling system shall be supplied with Dex-cool or equal extended life antifreeze protected to a point of -34 degrees F.

3.1.5.3 Shall provide Engine coolant filter if available by engine manufacturer.

3.1.5.4 Loader shall have Axle and Service brake coolers largest available by manufacturer.

3.1.6 AIR INDUCTION SYSTEM

3.1.6.1 Shall have dry type dual element (2 stage) air cleaner with pre-cleaner.

3.1.6.2 Unit shall have dash mounted air filter restriction indicator that is operator visible when service is required.

1 OEM / Aftermarket

Coolers

REQUEST FOR QUOTATION
CRFQ DOT1900000125
(Class 353) 4WD Rubber Tired Wheel Loader with Bucket (7019EC15)

3.1.7 EXHAUST SYSTEM

3.1.7.1 Complete aluminized exhaust system shall be manufacturers standard for unit specified.

3.1.8 ELECTRICAL SYSTEM

3.1.8.1 Unit's electrical system shall be manufacturer's noise suppression wiring.

3.1.8.2 System shall be 12 volts and/or 24 volts negative ground (manufacturers standard).

3.1.8.3 Shall have a minimum of (2) two batteries 950 CCA minimum each.

3.1.8.4 Shall have master switch corrosion resistant.

3.1.8.5 Electrical system shall have corrosion-prevention package (corrosion resistant spray, sealer, di-electric grease etc. on all exposed wiring with protective covers)

3.1.9 CHARGING SYSTEM

3.1.9.1 Unit shall have 60-amp alternator minimum with internal regulator.

3.1.10 ENGINE FUEL SYSTEM

3.1.10.1 Fuel capacity shall be 12 working hours, minimum.

3.1.10.2 Unit shall be provided with a fuel/water separator.

3.1.11 TRANSMISSION

3.1.11.1 Transmission shall be automatic / Power- Shift or Hydrostatic.

3.1.11.2 Transmission shall have a minimum of 3 forward speeds and minimum of 2 reverse speeds.

REQUEST FOR QUOTATION
CRFQ DOT1900000125
(Class 353) 4WD Rubber Tired Wheel Loader with Bucket (7019EC15)

3.1.11.3 Shall be single lever Joystick controlled with auxiliary function or equal.

3.1.12 DIFFERENTIAL

3.1.12.1 Shall have manufacturers standard front and rear with manual Differential lock with wheel spin control.

*Manufactures
Standard*

3.1.13 AXLES

3.1.13.1 Front axle shall be fixed.

3.1.13.2 Rear axle shall oscillate 10-degrees minimum each direction.

3.1.14 BRAKES

3.1.14.1 Parking brake shall be spring applied, hydraulically released, driveline mounted, sealed wet multi-disc or equal.

3.1.14.2 Park brake shall be independent of service brake.

3.1.14.3 Shall have wet type disk service brakes.

3.1.15 HYDRAULIC SYSTEM

3.1.15.1 Unit shall provide hydraulic lift, lower, dump, roll back and float plus third spool auxiliary valve with cab controller.

3.1.15.2 All hydraulic cylinders shall be double action chrome plated piston type.

3.1.15.3 A sight glass shall be provided for daily checking of hydraulic oil.

3.1.15.4 Hydraulic system relief pressure shall be 3000 PSI minimum.

3.1.15.5 Unit shall be equipped with manufacturer's standard hydraulic filtering system.

3.1.15.6 Unit Shall have automatic ride control.

REQUEST FOR QUOTATION
CRFQ DOT1900000125
(Class 353) 4WD Rubber Tired Wheel Loader with Bucket (7019EC15)

3.1.16 TIRES

3.1.16.1 Tires shall be correct ply and rating grader/loader type front and rear tubeless radials 17.5/R25 size 1-star L-3.

tire size

3.1.16.2 Overall tire width (outside left to outside right) shall not exceed 8.5 - feet maximum.

3.1.17 CAB AND RELATED ACCESSORIES

3.1.17.1 Cab shall be OSHA approved ROPS/FOPS.

3.1.17.2 Cab shall be insulated and pressurized.

3.1.17.3 Cab shall be equipped with heater, defroster and air conditioning installed by manufacturer with fresh air filter system.

3.1.17.4 Cab shall have front and rear windshield wipers and washers.

3.1.17.5 Cab shall have safety, tinted glass at all locations.

3.1.17.6 Cab exterior shall have left, and right side largest available exterior mirrors heated and one in cab rear view mirror.

3.1.17.7 Cab must have at least one (1) entry door, lockable.

3.1.17.8 Unit shall be provided with non-skid self-cleaning steps and hand holds left side.

3.1.17.9 Seat shall be heated cloth type with headrest and independent height and weight adjustment with orange colored seatbelt.

3.1.17.10 Unit shall have adjustable tilt and telescoping steering wheel.

3.1.17.11 Front and Rear full coverage fenders shall be provided on unit.

3.1.17.12 Fire extinguisher shall be provided and mounted in unit.

REQUEST FOR QUOTATION
CRFQ DOT1900000125
(Class 353) 4WD Rubber Tired Wheel Loader with Bucket (7019EC15)

3.1.17.13 AM/FM weather-band radio with remote auxiliary port shall be provided and installed in cab.

3.1.17.14 Cab shall have one (1) 12-volt power port.

3.1.17.15 Cab shall have factory embedded payload scale.

3.1.17.15.1 Scale shall provide weight each bucket load plus total load for a minimum of 10-trucks total and 5-different materials.

3.1.17.16 Cab shall have factory installed rear view camera and radar object detection system.

3.1.17.17 Cab shall have factory installed sun visor/sunshield

Dealer / vs / Factory installed

*Scale
No-Printer*

3.1.18 LIGHTING SYSTEM

3.1.18.1 Unit shall have two (2) hi/low halogen beam front lights for roading and working.

3.1.18.2 Wheel loader shall have four (4) LED work lights, two (2) front and two (2) rear mounted in accordance to cab features.

3.1.18.3 Unit shall have LED flash/turn signals (front/rear) stoplights and taillights.

3.1.18.4 Unit shall be provided with console and dome lighting.

3.1.18.5 Shall have one (1) Class 1 LED beacon, amber mounted on machine.

3.1.18.6 Unit shall be equipped with OSHA approved audible reverse alarm.

3.1.18.7 Articulation locking bar and pin shall be provided.

3.1.19 UNIT INSTRUMENTATION:

Shall provide the following:

3.1.19.1 Tachometer

REQUEST FOR QUOTATION
CRFQ DOT1900000125
(Class 353) 4WD Rubber Tired Wheel Loader with Bucket (7019EC15)

3.1.19.2 Speedometer

3.1.19.3 Hour meter shall be operable from engine operation not key switch.

3.1.19.4 Fuel gauge

3.1.19.5 Ammeter/or volt meter

3.1.19.6 Coolant temperature indicator with audible buzzer or visual warning light.

3.1.19.7 Engine oil pressure indicator with audible buzzer or visual warning light.

3.1.19.8 Transmission oil and/or hydraulic oil temperature indicator or hydraulic filter bypass indicator.

3.1.19.9 One (1) complete set of replacement filters shall be provided with each unit upon delivery. *? filters ?*

3.1.19.10 Unit shall be delivered to WVDOH with all manufacturers recommended safety related decals and safety features intact. *? PPF ?*

3.1.20 BUCKET and Bucket Linkage Type:

3.1.20.1 The general-purpose bucket shall be 2.00 cubic yard minimum. And 2.5 cubic yard maximum.

3.1.20.2 Bucket width shall match overall width of machine.

3.1.20.3 Bucket shall roll back 40 degrees at ground level and dump at 42 degrees minimum at full height.

3.1.20.4 Unit shall be equipped with automatic return to work leveler for bucket and attachments.

3.1.20.5 The cutting edge shall welded to bucket and a bolt-on replaceable cutting edge shall be mounted under it.

3.1.20.6 Bucket Linkage type shall be Z-bar type or equal. *parallel linkage*

**REQUEST FOR QUOTATION
CRFQ DOT1900000125
(Class 353) 4WD Rubber Tired Wheel Loader with Bucket (7019EC15)**

3.1.20.7 Bucket shall have lifting eyes on left and right side and center of bucket.

3.1.21 FORKS (Exhibit C) and BRUSH GRAPPLES (Exhibit D) will be optional line items on pricing page. (Exhibit A)

3.1.21.1 Log and lumber style Forks shall be adjustable width, manufacturers standard size for unit bid Craig or equal.

3.1.21.2 Shall have Land Clearing Rake manufacturers standard size for unit bid Craig brand or equal.

3.1.23 PAINT

3.1.23.1 The Loader and attachments shall be painted manufacturers standard paint color with all decals.

3.2 Miscellaneous:

3.2.1 Vendor Responsibility

3.2.1.1 The vendor shall be responsible to furnish a 4 wheel drive, rubber tired wheel loader with bucket that is properly engineered and that confirms to all and any laws governing such equipment.

3.2.1.2 Unspecified Accessories & Features: All parts, equipment, accessories, material, design and performance characteristics not specified herein, but which are necessary to provide a complete unit, must be furnished with each unit and required to conform to strength, quality of material, and quality of workmanship to those which are advertised and provided to the market in general by the unit industry.

3.2.1.3 All parts and accessories advertised and regularly supplied as standard shall be included, except those which would represent duplication of these specified and except those which, by specification, are not to be furnished.

3.2.1.4 All standard safety features required by Federal and State Law, shall be included.

REQUEST FOR QUOTATION
CRFQ DOT1900000125
(Class 353) 4WD Rubber Tired Wheel Loader with Bucket (7019EC15)

3.2.1.5 Inspection: WVDOH requires unit shall have a West Virginia State inspection sticker upon delivery.

3.3.1.6 Unit shall be delivered: to WVDOH with all manufacturers recommended safety related decals and safety features intact.

3.2.2 Representative Unit for Test:

3.2.2.1 The successful vendor must (if specified) provide the DOH one (1) completed represented unit to be observed and evaluated on each order to insure compliance with specification. If requested, the time period for testing and evaluation shall be seven (7) working days following receipt of the unit. DOH will incur no obligation for deterioration of surfaces, finishes, seals, and mechanical or electrical parts on the unit resulting from operation and testing within the limits of these specifications; nor will DOH incur obligation for damage to the unit resulting from failure to meet specifications when due care and attention is given by DOH and testing is done within the limits of these specifications. Failure of the pilot unit to satisfactorily meet specifications as bid may be cause for cancellation of the purchase order and return of the delivered unit along with all associated equipment to the vendor at the vendor's expense.

3.2.3 Operating and Service Manuals and Parts Lists:

3.2.3.1 An operator's manual must be included with each unit upon delivery. A "line sheet" (if applicable) and the "Equipment Preventative Maintenance Questionnaire", (Exhibit "B") must be with pilot unit upon delivery, Attn: Marcia Lee. There must be 12 service/shop/maintenance manuals and 14 parts manuals; USB storage drive is preferred in lieu of parts manuals. Manuals and USB storage drive shall be delivered upon completion of delivery of total units. Failure to do so will delay payment.

3.2.4 Training:

3.2.4.1 Manufacturers and/or dealers will be required to stage a thorough seminar on the subjects of Preventative Maintenance, Operator, and Mechanic Training. In order to keep operators and mechanics updated, the successful vendor shall conduct training sessions covering the operation, maintenance, trouble-shooting with each purchase order against this open end contract.

REQUEST FOR QUOTATION
CRFQ DOT1900000125
(Class 353) 4WD Rubber Tired Wheel Loader with Bucket (7019EC15)

Manufacturers and/or dealers shall be required to furnish the Training Academy with one (1) Operator's Manual to be shipped direct to

WVDOH
Training Academy
P.O. Box 610
Buckhannon, West Virginia 26201

Prior to delivery of the pilot unit. Training seminar to be held at the WVDOT, Equipment Division, Buckhannon, WV.

3.2.5 Preventative Maintenance & Operator Procedures:

3.2.5.1 Manufacturers and/or dealers will be required to submit to the Equipment Division, in addition to the operating and service manuals, booklets and pamphlets explaining the Preventative Maintenance and Operator Procedures to be used by the operators of this equipment, and must include such things as daily prestart inspection procedure, service schedule, and routine maintenance required, safety precautions, etc. The successful vendor shall furnish all training aids; i.e. videos, projectors as required in conducting the training.

3.2.6 Warranty and Service Policy:

3.2.6.1 The bid shall include a breakdown of the complete manufacturer's warranty per section. The unit must be accompanied upon delivery by the unit's manufacturer's executed warranty and service policy.

4. CONTRACT AWARD:

- 4.1 Contract Award:** The Contract is intended to provide Agencies with a purchase price on all Contract Items. The Contract shall be awarded to the Vendor that provides the Contract Items meeting the required specifications for the lowest overall total cost as shown on the Pricing Pages.
- 4.2 Pricing Pages:** Vendor should complete the Pricing Pages (Exhibit A) by inserting the year, make, model and inserting the quoted unit price. Vendor should take Estimated Quantity and multiply by unit price to get grand total. Vendor should complete the Pricing Pages in their entirety as failure to do so may result in Vendor's bids being disqualified.

REQUEST FOR QUOTATION
CRFQ DOT1900000125
(Class 353) 4WD Rubber Tired Wheel Loader with Bucket (7019EC15)

Vendor should electronically enter the information into the Pricing Pages through wvOASIS, if available, or as an electronic document. In most cases, the Vendor can request an electronic copy of the Pricing Pages for bid purposes by sending an email request to the following address: Crystal.G.Rink@wv.gov.

5. ORDERING AND PAYMENT:

- 5.1 Ordering:** Vendor shall accept orders through wvOASIS, regular mail, facsimile, e-mail, or any other written form of communication. Vendor may, but is not required to, accept on-line orders through a secure internet ordering portal/website. If Vendor has the ability to accept on-line orders, it should include in its response a brief description of how Agencies may utilize the on-line ordering system. Vendor shall ensure that its on-line ordering system is properly secured prior to processing Agency orders on-line.
- 5.2 Payment:** Vendor shall accept payment in accordance with the payment procedures of the State of West Virginia.

6. DELIVERY AND RETURN:

- ISO on pilot*
- 6.1 Delivery Time:** A completed pilot model for inspection must be provided within 120 working day(s) after receipt of the pilot model order by the successful vendor. Vendor shall deliver standard orders within 180 working days after standard orders are received. Working day is defined as any week day, Monday thru Friday, excluding Federal and State Holidays. Vendor shall ship all orders until a minimum delivery quantity is met.
- 6.2 Late Delivery:** The Agency placing the order under this Contract must be notified in writing if orders will be delayed for any reason. Any delay in delivery that could cause harm to an Agency will be grounds for cancellation of the delayed order, and/or obtaining the items ordered from a third party.
- Any Agency seeking to obtain items from a third party under this provision must first obtain approval of the Purchasing Division.
- 6.3 Delivery Payment/Risk of Loss:** Standard order delivery shall be F.O.B. destination to the Agency's location. Vendor shall include the cost of standard order

REQUEST FOR QUOTATION
CRFQ DOT1900000125
(Class 353) 4WD Rubber Tired Wheel Loader with Bucket (7019EC15)

delivery charges in its bid pricing/discount and is not permitted to charge the Agency separately for such delivery.

6.4 Conditions of Unit(s) Upon Delivery: All units must arrive at the prescribed delivery point having been completely pre-serviced with oil, lubricants, and coolant. All prescribed precautions pertaining to first operations and break-in of the unit are to be posted conspicuously on the unit for ready observance by the operator.

6.5 Delivery Point: Delivery point of the completed representative unit will be the WVDOH, Equipment Division, 83 Brushy Fork Road Crossing, Buckhannon, WV 26201.

7. VENDOR DEFAULT:

7.1 The following shall be considered a vendor default under this Contract.

7.1.1 Failure to provide Contract Items in accordance with the requirements contained herein.

7.1.2 Failure to comply with other specifications and requirements contained herein.

7.1.3 Failure to comply with any laws, rules, and ordinances applicable to the Contract Services provided under this Contract.

7.1.4 Failure to remedy deficient performance upon request.

7.2 The following remedies shall be available to Agency upon default.

7.2.1 Immediate cancellation of the Contract.

7.2.2 Immediate cancellation of one or more release orders issued under this Contract.

REQUEST FOR QUOTATION
CRFQ DOT1900000125
(Class 353) 4WD Rubber Tired Wheel Loader with Bucket (7019EC15)

7.2.3 Any other remedies available in law or equity.

8. MISCELLANEOUS:

- 8.1 No Substitutions:** Vendor shall supply only Contract Items submitted in response to the Solicitation unless a contract modification is approved in accordance with the provisions contained in this Contract.
- 8.2 Reports:** Vendor shall provide quarterly reports and annual summaries to the Agency showing the Agency's items purchased, quantities of items purchased, and total dollar value of the items purchased. Vendor shall also provide reports, upon request, showing the items purchased during the term of this Contract, the quantity purchased for each of those items, and the total value of purchases for each of those items. Failure to supply such reports may be grounds for cancellation of this Contract.
- 8.3 Contract Manager:** During its performance of this Contract, Vendor must designate and maintain a primary contract manager responsible for overseeing Vendor's responsibilities under this Contract. The Contract manager must be available during normal business hours to address any customer service or other issues related to this Contract. Vendor should list its Contract manager and his or her contact information below.

Contract Manager: Miranda Novak
Telephone Number: 724-415-7777
Fax Number: 304-842-6126
Email Address: mnoyak@rish.com

EXHIBIT A**CRFQ DOT1900000125****4 WHEEL DRIVE RUBBER TIRED LOADER with Bucket**

Item No.	Description:	Make/Model & Year	Estimated Unit Quantity	Unit Price	Item Total Cost
1	One Complete Unit: 4 Wheel Drive Rubber Tired Wheel Loader with Bucket	2020 Komatsu WA200-8	50	\$ 181,093.00	\$ 9,054,650.00
2	Optional: Log and Lumber Forks	Rockland LFW-20-48-72-QC	50	\$ 9953.00	\$ 497,650.00
3	Optional: Land Clearing Rake	Rockland LRC-20-QC	50	\$ 12,533.00	\$ 626,650.00
Total Bid Amount		➔			\$ 10,178,950.00

Vendor Information

Company Name: Rish Equipment Co.

Contact Manager: Miranda Novak

Address: 100 Heliport Loop
Bridgeport NV 26330

Phone: 724-415-7777

Fax: 304-842-6126

Email: mnovak@rish.com

Signature: 

N/A

EXHIBIT B

EQUIPMENT PREVENTATIVE MAINTENANCE QUESTIONNAIRE

THIS FORM MUST BE COMPLETED IN ITS ENTIRETY BY SUCCESSFUL BIDDER OR MANUFACTURER'S TECHNICAL REPRESENTATIVE PRIOR TO DELIVERY TO THE WVDOH.

DESCRIPTION: _____ MAKE: _____

MODEL: _____ YEAR: _____ PURCHASE AMOUNT: _____

ENGINE: MAKE: _____ MODEL: _____ FUEL TYPE: _____

HORSEPOWER: _____ CYLINDER: _____ ENGINE SERIAL: _____

COOLING SYSTEM CAPACITY: _____

BELTS: DESCRIPTION: _____ PART NUMBERS: _____

GVW: _____ AXLE CAPACITY: FRONT: _____ REAR: _____

TIRES: FRONT MAKE & SIZE: _____

REAR MAKE & SIZE: _____

DIMENSIONS OF UNIT: LENGTH: _____ WIDTH: _____ LENGTH: _____

VENDOR CONTACT PERSON: _____ PHONE: _____

PARTS:

BATTERY MAKE: _____ MODEL: _____ CCA: _____

TOP OR SIDE POST: _____ DIMENSIONS: LENGTH _____ WIDTH _____ HEIGHT _____

SPARK PLUGS OR FUEL INJECTORS MAKE: _____ PART #: _____

FUEL PUMP OR INJECTION PUMP MAKE: _____ MODEL: _____

ALTERNATOR MAKE: _____ PART #: _____

STARTER MAKE: _____ PART #: _____

TURBO CHARGER MAKE: _____ PART #: _____

TRANS. MAKE: _____ MODEL: _____ AUTO/MANUAL: _____

HYDRAULIC PUMP MAKE: _____ MODEL: _____

FILTERS MAKE PART NO. LUBRICANT MANUFACTURER TYPE

OIL _____	ENGINE _____
AIR INNER _____	TRANSMISSION _____
AIR OUTER _____	POWER STEERING _____
FUEL PRIMARY _____	HYDRAULIC _____
FUEL SECONDARY _____	DIFFERENTIALS _____
COOLANT _____	BRAKE FLUID _____
HYDRAULIC _____	COOLANT _____
OTHER _____	OTHER _____

West Virginia Ethics Commission



Disclosure of Interested Parties to Contracts

Pursuant to *W. Va. Code* § 6D-1-2, a state agency may not enter into a contract, or a series of related contracts, that has/have an actual or estimated value of \$1 million or more until the business entity submits to the contracting state agency a Disclosure of Interested Parties to the applicable contract. In addition, the business entity awarded a contract is obligated to submit a supplemental Disclosure of Interested Parties reflecting any new or differing interested parties to the contract within 30 days following the completion or termination of the applicable contract.

For purposes of complying with these requirements, the following definitions apply:

"Business entity" means any entity recognized by law through which business is conducted, including a sole proprietorship, partnership or corporation, but does not include publicly traded companies listed on a national or international stock exchange.

"Interested party" or *"Interested parties"* means:

- (1) A business entity performing work or service pursuant to, or in furtherance of, the applicable contract, including specifically sub-contractors;
- (2) the person(s) who have an ownership interest equal to or greater than 25% in the business entity performing work or service pursuant to, or in furtherance of, the applicable contract. (This subdivision does not apply to a publicly traded company); and
- (3) the person or business entity, if any, that served as a compensated broker or intermediary to actively facilitate the applicable contract or negotiated the terms of the applicable contract with the state agency. (This subdivision does not apply to persons or business entities performing legal services related to the negotiation or drafting of the applicable contract.)

"State agency" means a board, commission, office, department or other agency in the executive, judicial or legislative branch of state government, including publicly funded institutions of higher education: Provided, that for purposes of *W. Va. Code* § 6D-1-2, the West Virginia Investment Management Board shall not be deemed a state agency nor subject to the requirements of that provision.

The contracting business entity must complete this form and submit it to the contracting state agency prior to contract award and to complete another form within 30 days of contract completion or termination.

This form was created by the State of West Virginia Ethics Commission, 210 Brooks Street, Suite 300, Charleston, WV 25301-1804. Telephone: (304)558-0664; fax: (304)558-2169; e-mail: ethics@wv.gov; website: wv.ethics.wv.gov.

West Virginia Ethics Commission
Disclosure of Interested Parties to Contracts

(Required by W. Va. Code § 8D-1-2)

Name of Contracting Business Entity: Rish Equipment Co Address: 100 Heliport Loop
Bridgeport WV 26330

Name of Authorized Agent: Miranda Novak Address: same

Contract Number: DOT 1900000125 Contract Description: Wheel Loader

Governmental agency awarding contract: WV DOH

Check here if this is a Supplemental Disclosure

List the Names of Interested Parties to the contract which are known or reasonably anticipated by the contracting business entity for each category below (attach additional pages if necessary):

1. Subcontractors or other entities performing work or service under the Contract

Check here if none, otherwise list entity/individual names below.

2. Any person or entity who owns 25% or more of contracting entity (not applicable to publicly traded entities)

Check here if none, otherwise list entity/individual names below.

3. Any person or entity that facilitated, or negotiated the terms of, the applicable contract (excluding legal services related to the negotiation or drafting of the applicable contract)

Check here if none, otherwise list entity/individual names below.

Signature: [Handwritten Signature]

Date Signed: 7/25/19

Notary Verification

State of West Virginia, County of Harrison:

I, Miranda M. Novak, the authorized agent of the contracting business entity listed above, being duly sworn, acknowledge that the Disclosure herein is being made under oath and under the penalty of perjury.

Taken, sworn to and subscribed before me this 25th day of July, 2019.

Sheeta R. Parker
Notary Public's Signature

To be completed by State Agency:

Date Received by State Agency: _____

Date submitted to Ethics Commission: _____

Governmental agency submitting Disclosure: _____

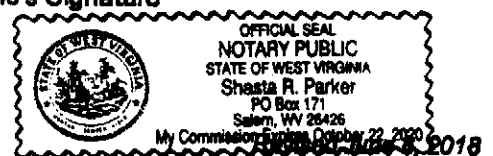

STATE OF WEST VIRGINIA
Purchasing Division

PURCHASING AFFIDAVIT

CONSTRUCTION CONTRACTS: Under W. Va. Code § 5-22-1(i), the contracting public entity shall not award a construction contract to any bidder that is known to be in default on any monetary obligation owed to the state or a political subdivision of the state, including, but not limited to, obligations related to payroll taxes, property taxes, sales and use taxes, fire service fees, or other fines or fees.

ALL CONTRACTS: Under W. Va. Code §5A-3-10a, no contract or renewal of any contract may be awarded by the state or any of its political subdivisions to any vendor or prospective vendor when the vendor or prospective vendor or a related party to the vendor or prospective vendor is a debtor and: (1) the debt owed is an amount greater than one thousand dollars in the aggregate; or (2) the debtor is in employer default.

EXCEPTION: The prohibition listed above does not apply where a vendor has contested any tax administered pursuant to chapter eleven of the W. Va. Code, workers' compensation premium, permit fee or environmental fee or assessment and the matter has not become final or where the vendor has entered into a payment plan or agreement and the vendor is not in default of any of the provisions of such plan or agreement.

DEFINITIONS:

"Debt" means any assessment, premium, penalty, fine, tax or other amount of money owed to the state or any of its political subdivisions because of a judgment, fine, permit violation, license assessment, defaulted workers' compensation premium, penalty or other assessment presently delinquent or due and required to be paid to the state or any of its political subdivisions, including any interest or additional penalties accrued thereon.

"Employer default" means having an outstanding balance or liability to the old fund or to the uninsured employers' fund or being in policy default, as defined in W. Va. Code § 23-2c-2, failure to maintain mandatory workers' compensation coverage, or failure to fully meet its obligations as a workers' compensation self-insured employer. An employer is not in employer default if it has entered into a repayment agreement with the Insurance Commissioner and remains in compliance with the obligations under the repayment agreement.

"Related party" means a party, whether an individual, corporation, partnership, association, limited liability company or any other form or business association or other entity whatsoever, related to any vendor by blood, marriage, ownership or contract through which the party has a relationship of ownership or other interest with the vendor so that the party will actually or by effect receive or control a portion of the benefit, profit or other consideration from performance of a vendor contract with the party receiving an amount that meets or exceeds five percent of the total contract amount.

AFFIRMATION: By signing this form, the vendor's authorized signer affirms and acknowledges under penalty of law for false swearing (W. Va. Code §61-5-3) that: (1) for construction contracts, the vendor is not in default on any monetary obligation owed to the state or a political subdivision of the state, and (2) for all other contracts, that neither vendor nor any related party owe a debt as defined above and that neither vendor nor any related party are in employer default as defined above, unless the debt or employer default is permitted under the exception above.

WITNESS THE FOLLOWING SIGNATURE:

Vendor's Name: Rish Equipment Co.

Authorized Signature: [Signature] Date: 7/25/19

State of West Virginia

County of Harrison to-wit:

Taken, subscribed, and sworn to before me this 25th day of July, 2019.

My Commission expires October 22, 2020.

AFFIX SEAL HERE

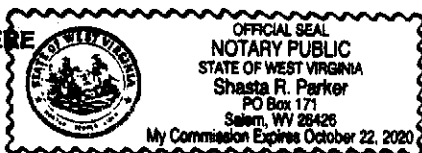

NOTARY PUBLIC

Shasta R. Parker

KOMATSU®

WA200-8

Tier 4 Final Engine

WHEEL LOADER

WA200



NET HORSEPOWER

126 HP @ 2000 rpm
94 kW @ 2000 rpm

OPERATING WEIGHT

25,827–26,489 lb
11715 – 12015 kg

BUCKET CAPACITY

2.6 – 3.1 yd³
2.0 – 2.4 m³

WALK-AROUND

WA200-8



Photos may include optional equipment.

NET HORSEPOWER

126 HP @ 2000 rpm
94 kW @ 2000 rpm

OPERATING WEIGHT

25,827– 26,489 lb
11715 – 12015 kg

BUCKET CAPACITY

2.6 – 3.1 yd³
2.0 – 2.4 m³

KOMATSU
CARE

AGILITY AND PRODUCTIVITY

Proven, Fourth Generation Hydrostatic Transmission:

- Quick Acceleration
- Dynamic Braking
- Variable Traction Control System
- Creeping Mode

Versatile Parallel Z-bar (PZ) linkage:

- Parallel lift for handling pallets or pipe
- Large breakout force for earth work

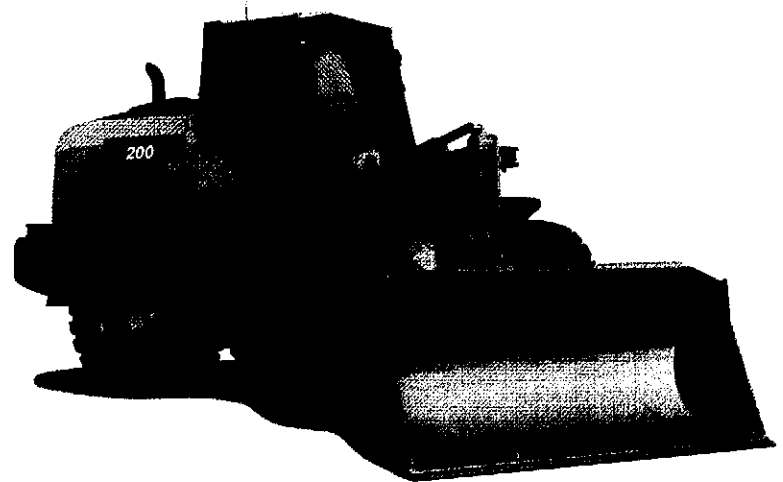

A powerful Komatsu SAA4D107E-3 engine provides a net output of 94 kW 126 HP with up to four percent improved fuel consumption. This engine is EPA Tier 4 Final emissions certified.

New Variable Geometry Turbocharger (VGT) provides optimum air flow under all speed and load conditions. This Tier 4 Final version has improved performance.

Komatsu Diesel Oxidation Catalyst (KDOC) and new Selective Catalytic Reduction (SCR) systems reduce hydrocarbons, carbon monoxide, and NOx without interfering with daily operation.

Increased cooling capacity

- Auto-reversing fan is standard
- Wider core coolers
- Cooling system volume increased by 7.5%

Fluid neutral or better

Combined fuel and DEF consumption is equal to or less than the WA200-7 fuel consumption.

New spacious cab provides the operator with improved comfort and visibility.

Multi-function mono lever with proportional control switch.

New high resolution monitor panel:

- Enhanced and intuitive on-board diagnostics
- Integrated with KOMTRAX® Level 5
- Integrated with Komatsu Tier 4 Final technology

New rearview monitoring system is standard.

New high capacity air suspension seat with heat is standard.

Battery disconnect switch allows a technician to disconnect the power supply before servicing the machine.

Energy saving guidance:

- Six operator guiding messages
- Enhanced ecology gauge

New Komatsu auto idle shutdown helps reduce idle time and operating costs.

The KOMTRAX® telematics system is standard on Komatsu equipment with no subscription fees throughout the life of the machine. Using wireless technology, KOMTRAX® transmits valuable information such as location, utilization, and maintenance records to a PC or smartphone app. Custom machine reports are provided for identifying machine efficiency and operating trends. KOMTRAX® also provides advanced machine troubleshooting capabilities by continuously monitoring machine health.

New operator identification system tracks machine operation for up to 100 operators.

Swing-out cooler design allows access to service and clean the cooler assembly.

PRODUCTIVITY & ECOLOGY FEATURES

KOMATSU NEW ENGINE TECHNOLOGIES

New Tier 4 Final Engine

The Komatsu SAA4D107E-3 engine is EPA Tier 4 Final emissions certified, reduces fuel consumption, and provides exceptional performance. Based on Komatsu proprietary technologies developed over many years, this new diesel engine reduces nitrogen oxides (NOx) compared to Tier 4 interim levels.

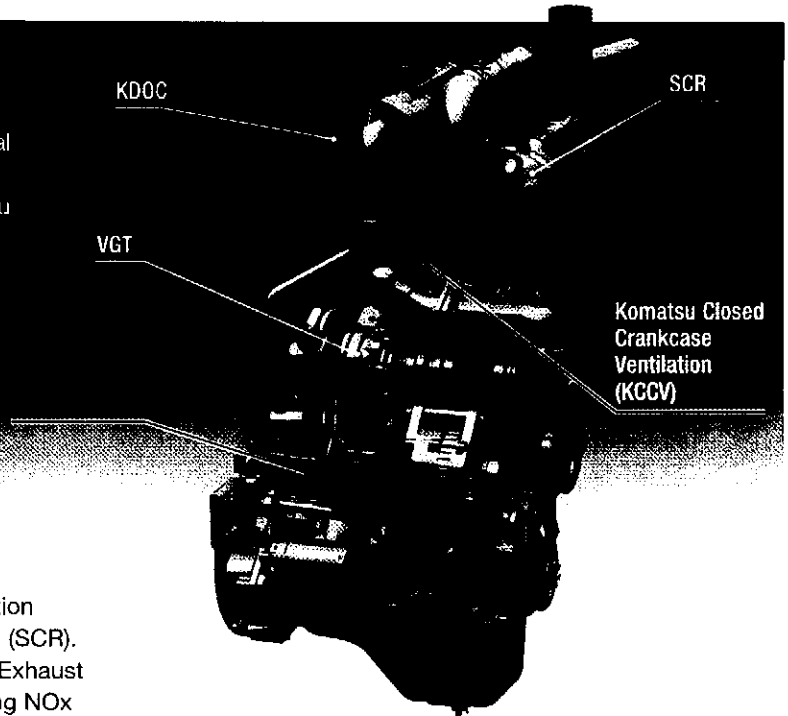

Technologies Applied to New Engine Heavy-Duty After Treatment System

This new system combines Komatsu Diesel Oxidation Catalyst (KDOC) and Selective Catalytic Reduction (SCR). The SCR NOx reduction system injects the Diesel Exhaust Fluid (DEF) at the proper rate, thereby decomposing NOx into non-toxic water (H₂O) and nitrogen gas (N₂).

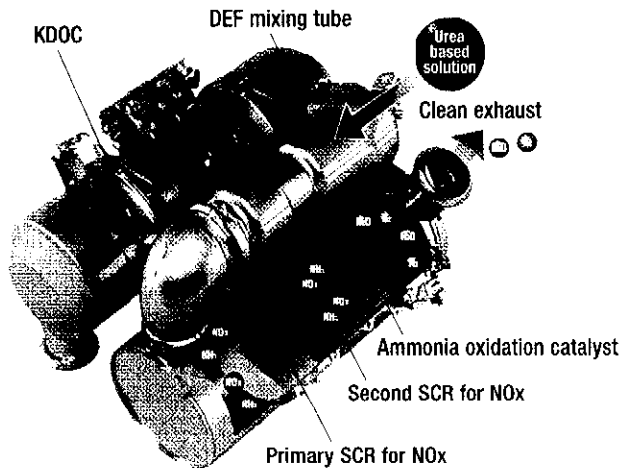

Heavy-Duty Cooled Exhaust Gas Recirculation (EGR) System

The system recirculates a portion of exhaust gas into the air intake and lowers combustion temperatures, thereby reducing NOx emissions. EGR gas flow is lower for Tier 4 Final with the addition of SCR technology. The system drastically reduces NOx while reducing fuel consumption.

Advanced Electronic Control System

An improved electronic control system more effectively manages engine parameters such as airflow rate, fuel injection parameters, and after treatment function. The control system also provides enhanced diagnostics through the monitor panel. Additionally, managing information via KOMTRAX helps customers track required maintenance.

Variable Geometry Turbocharger (VGT) system

The VGT provides optimal air flow under all engine speed and load conditions. The upgraded version provides better exhaust temperature management.

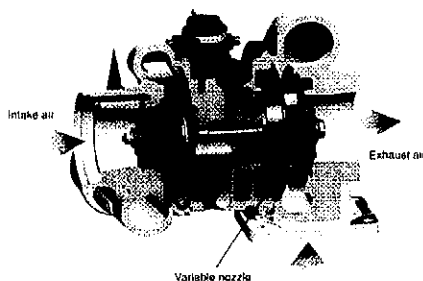

Heavy-Duty High-Pressure Common Rail (HPCR) fuel injection system

The system is specifically designed to achieve the optimal injection of fuel for near-complete combustion, which helps reduce Particulate Matter (PM) emissions.

WA2000-8

Hydrostatic Transmission (HST)

The HST provides quick travel response and aggressive drive into the pile. Full auto-shifting eliminates any gear shifting and kick-down operation to allow the operator to concentrate on digging and loading. The HST also acts as a dynamic brake to slow the loader. This dramatically extends the life of the wet disc brakes.

1-Pump, 2 Motor System

The 1-pump, 2 motor system allows for high-efficiency and high tractive effort. Engine power is transmitted hydraulically to a transfer case, then mechanically out to the differentials and the four driving wheels.

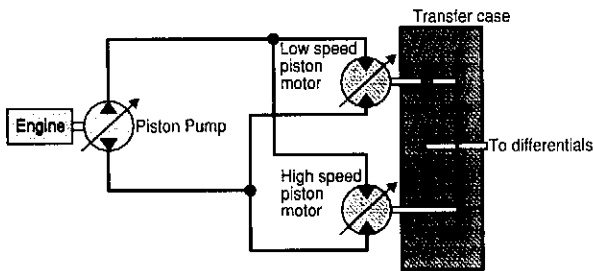

Variable Traction Control System

The variable speed control system is designed to adjust the tractive effort for each working condition. S-mode reduces tire spin in slippery or snowy conditions. Tractive effort can be adjusted in three stages when traction control switch is ON. Max traction provides the full, 100%, tractive effort.

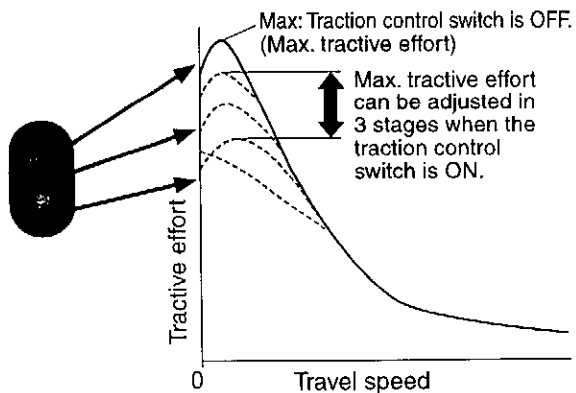

Creep Mode

Creep mode limits the travel speed in 1st speed range, while still allowing for full hydraulic flow.

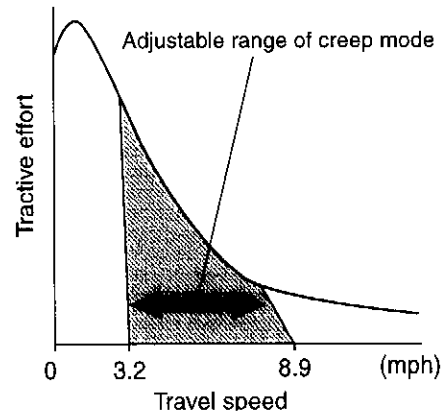
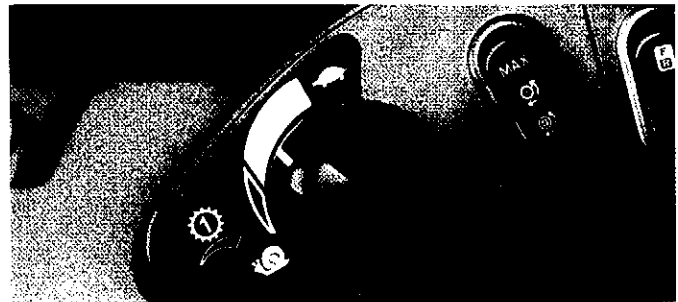

Komatsu Auto Idle Shutdown

In order to reduce unwanted idle time, Komatsu offers Komatsu auto idle shutdown. This function will shut the engine off and apply the parking brake and hydraulic lock after a preset idle time limit. This time limit can be set by the operator or service technician and may range from three to 60 minutes. It can also be deactivated by the operator.

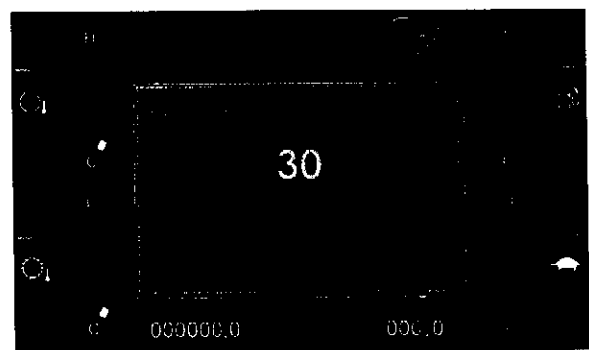

OPERATOR ENVIRONMENT



New Operator Seat

A new standard, heated, air-suspension seat provides enhanced support on rough roads and dampens machine vibrations, providing a more comfortable ride for the operator. The angle of the armrest is fully adjustable for optimum operator comfort. A secondary F-N-R switch is incorporated into the standard multi-function mono lever.

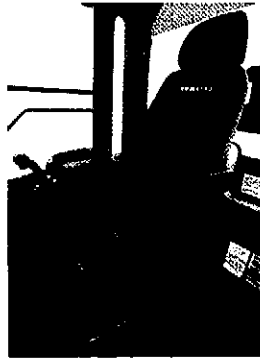

Tiltable / Telescopic Steering Wheel

The operator can tilt and telescope the steering wheel to allow maximum comfort and control. The two-spoke steering wheel allows maximum visibility of the monitor panel and the forward work environment.



Low Noise Design

Operator's ear noise level: 68 dB(A)*
Dynamic noise level (outside): 104 dB(A)**

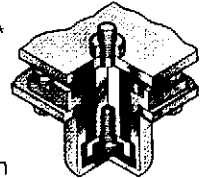

The large ROPS/FOPS cab is mounted with Komatsu's unique viscous mounts. The low-noise engine, hydraulically-driven fan, and hydraulic pumps are mounted with rubber cushions, and the cab sealing is improved to provide a quiet, low-vibration, comfortable operating environment.

* ISO 6396: 2008

** ISO 6395: 2008

Increased Cab Storage Area

The WA200-8 cab features a heated/cooled storage compartment on the right side of the cab to allow the operator to store items such as a beverage or lunch.

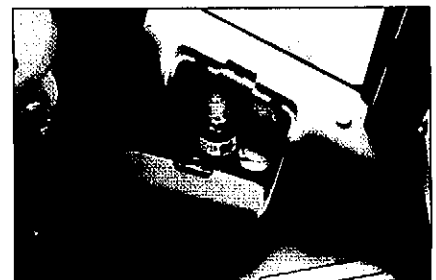

WA200-8

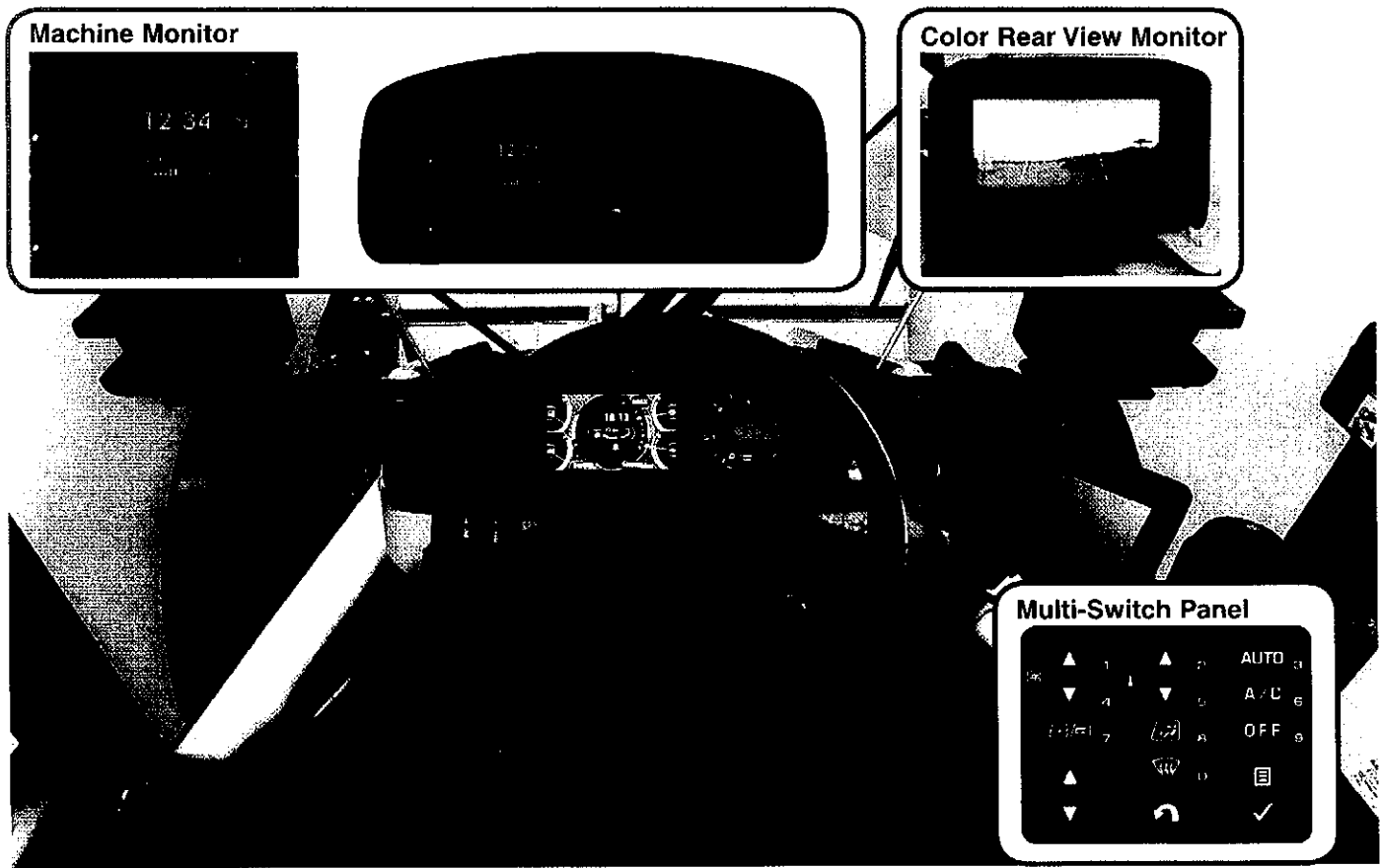

Standard Rearview Monitoring System

The dedicated, full-color monitor on the right side of the cab provides the operator with a rearview from the machine. This monitor can be always on or only on when the loader shifts into reverse. Guidelines provide the operator with visual cues for the width of the loader.



Secondary Engine Shutdown Switch

The engine stop switch enables machine shutdown when accessing the key switch is not possible.



Auxiliary Input (MP3 Jack) 12 V Outlets

An Aux input for audio devices is standard, as well as two 12 volt outlets. These are all located on the rear wall of the cab.

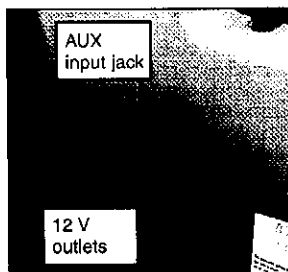

WORKING ENVIRONMENT

WA200-8

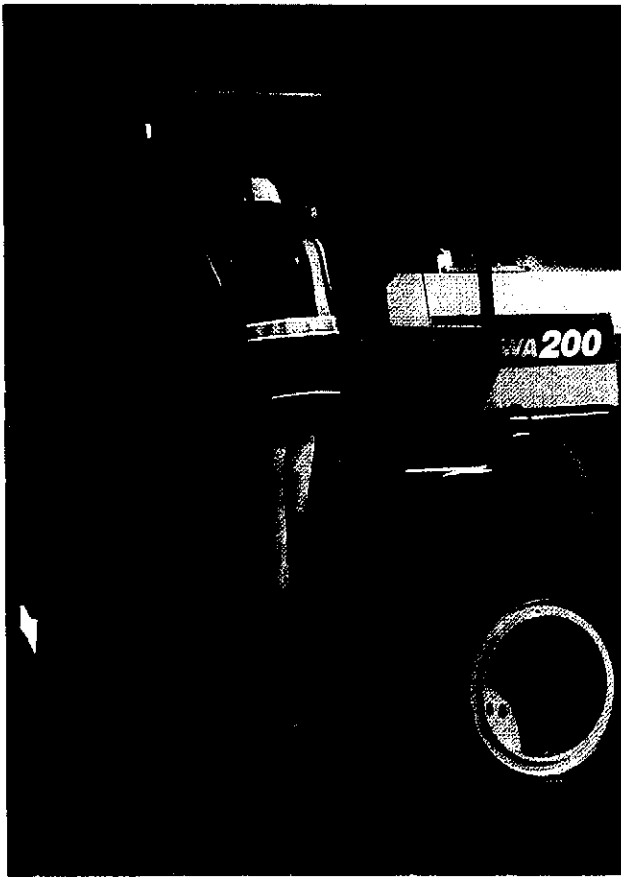

Easy Entry and Exit

The WA200-8 has an inclined ladder with wide steps and well-placed hand holds to ease entry and exit from the cab. The door latch can be reached from ground level to ease machine access.

Electronically Controlled Suspension System

The standard Electronically Controlled Suspension System or ride control system uses an accumulator, which absorbs some of the shock in the boom arm, giving the operator a much smoother ride. This reduces operator fatigue and reduces material spillage during load and carry operations. Ride control is speed sensitive and the activation speed can be adjusted in the monitor panel.

Multi-Function Mono Lever

The multi-function mono lever with EPC control for 3rd spool is standard. It includes a forward-neutral-reverse switch for quick and easy travel. Third spool attachments can be set to continual or proportional control via the monitor panel. This allows the operator to control the boom, bucket and attachment, all with a single lever.

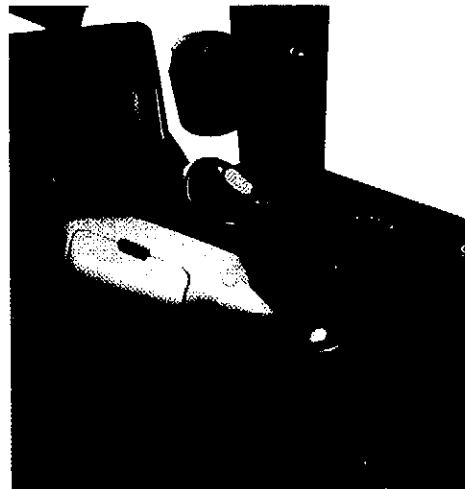

Attachment Selector Switch

Coupler equipped machines, which use buckets and forks, require a different flat level setting when switching between attachments. The attachment selector switch found in coupler equipped machines tells the loader which flat level to use.



Attachment selector switch

INFORMATION & COMMUNICATION TECHNOLOGY

New High Resolution LCD Monitor Panel

The new seven inch color LCD monitor panel displays operational information, ecology guidance and maintenance records. Information such as traction mode, coolant temp, oil and fuel levels are easy to read and help keep the operator informed of the machine's settings and conditions.

Machine monitor

- | | |
|---------------------------|------------------------------------|
| 1 LCD unit | 8 Engine coolant temperature gauge |
| 2 LED unit | 9 Fuel gauge |
| 3 Engine tachometer | 10 HST oil temperature gauge |
| 4 Speedometer | 11 Variable speed display |
| 5 Ecology gauge | 12 Message pilot lamp |
| 6 Air conditioner display | 13 Pilot lamps |
| 7 Traction level | 14 DEF level gauge |

Switch panel

- Air conditioner switches / Numeral key pad
- Function switches

Visual user menu

Pressing the menu button on the switch panel accesses the user-menu screen. The menus are grouped by function, with easy-to-understand, intuitive icons for easier machine operation.



Menu switch

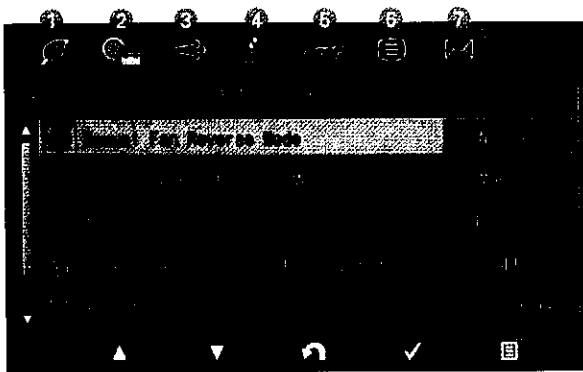

- Energy saving guidance
- Machine settings
- Aftertreatment devices regeneration
- SCR information
- Maintenance
- Monitor setting
- Mail check

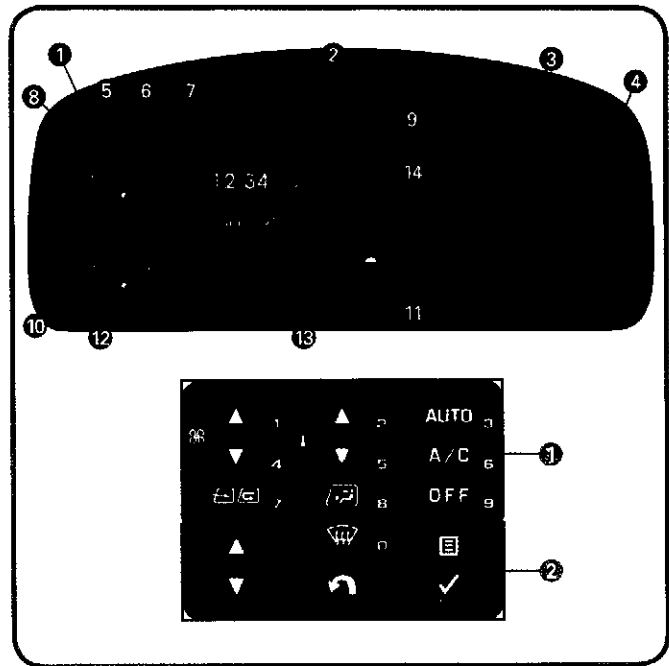

Operator Identification function

An operator identification (ID) code can be set for each operator, and used to manage operation information of individual machines through KOMTRAX. Data sent from KOMTRAX can be used to analyze operation status by operator job, as well as by machine.

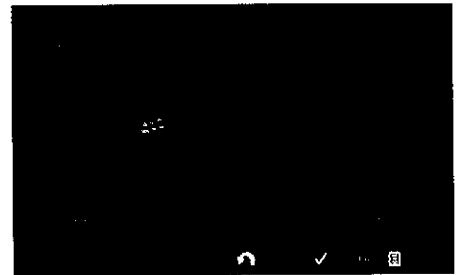

Monitor Panel with troubleshooting function minimizes downtime

Various meters, gauges and warning functions are centrally arranged on the monitor panel. The monitor simplifies start-up inspection and warns the operator with a lamp and buzzer if any abnormalities occur. Warnings are indicated in four levels, which the operator must acknowledge and clear.

Replacement times for oil and filters are also indicated.

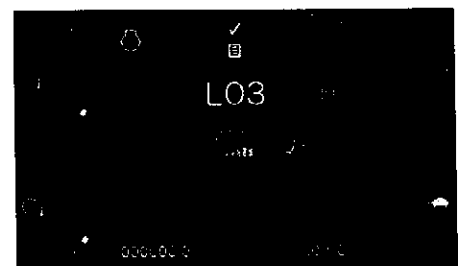

MAINTENANCE FEATURES

WA200-8

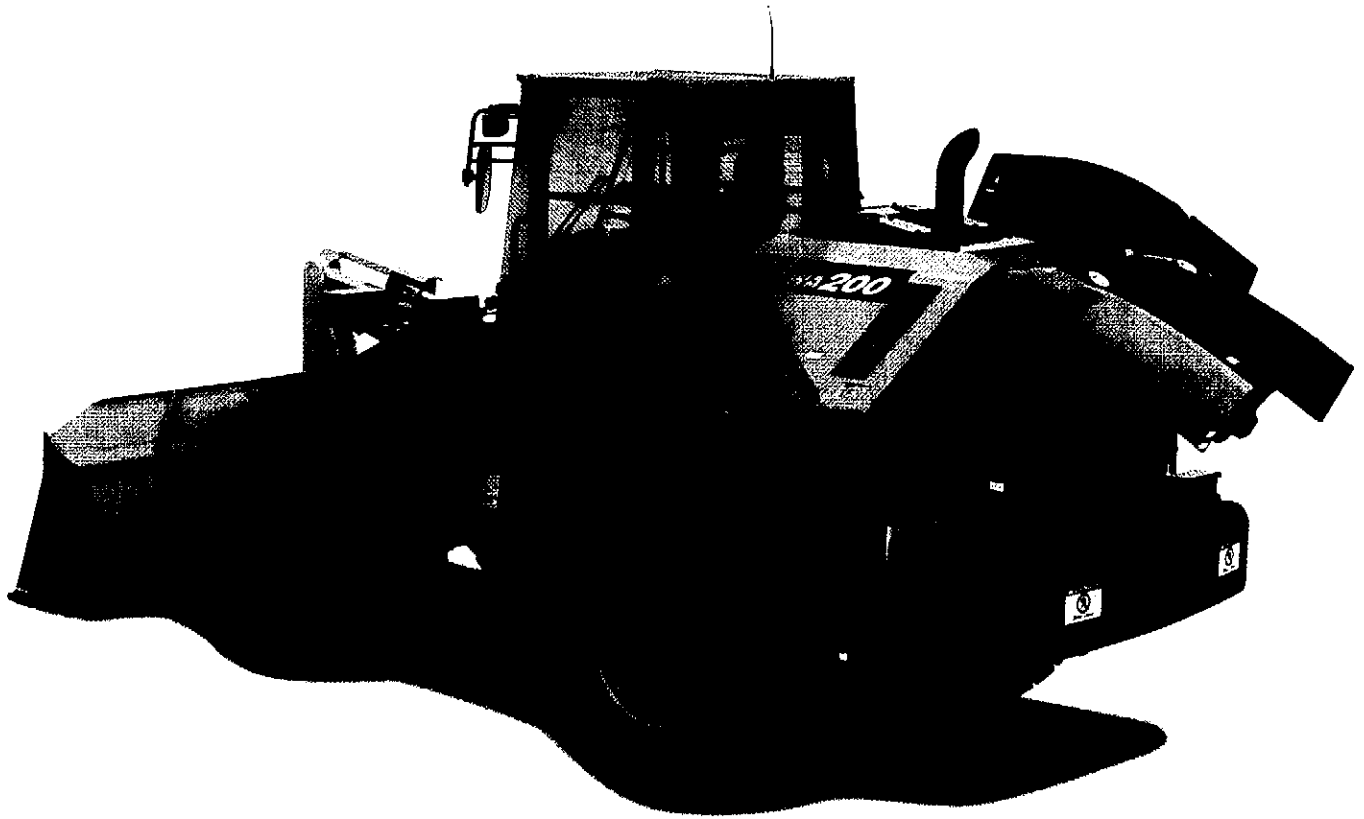

Side-opening Gull-wing Engine Doors

The large, gull-wing-type engine doors require minimal effort to open and close, thanks to gas assisted struts. The doors make access and daily maintenance easy. Large steps on the side of the frame also enhance accessibility.



Swing-Out Type Cooling Fan and Wide Core Radiator

The cooling fan swings out for cleaning. The coolers feature wider fin spacing cooling to reduce clogging.



Automatic Reversing Fan

The engine cooling fan is hydraulically driven. It can be set to reverse automatically during operation. Fan reverse mode and timing can be controlled through the monitor.

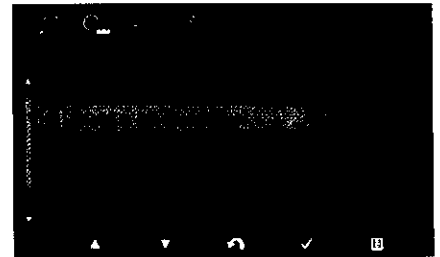

Battery Disconnect Switch

The battery disconnect switch is located on the right side of the machine. This can be used to disconnect power when performing service work on the machine.



Engine Compartment

The WA200-8 engine compartment is designed for easy serviceability. Placement of maintenance items, such as filters, dipsticks, and oil-fill locations are laid out for easy-to-reach access.

Engine air filter

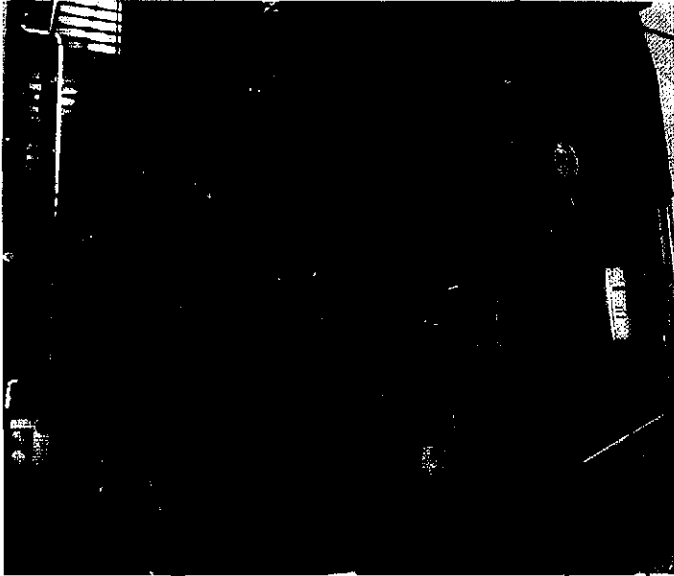

Engine oil dipstick and fill

Fuel filter

Fuel pre-filter and priming pump

DEF Tank

The DEF tank is ground-level accessible on the left side of the machine near the cab door for easy access. The tank features a sight glass that helps prevent overfilling.

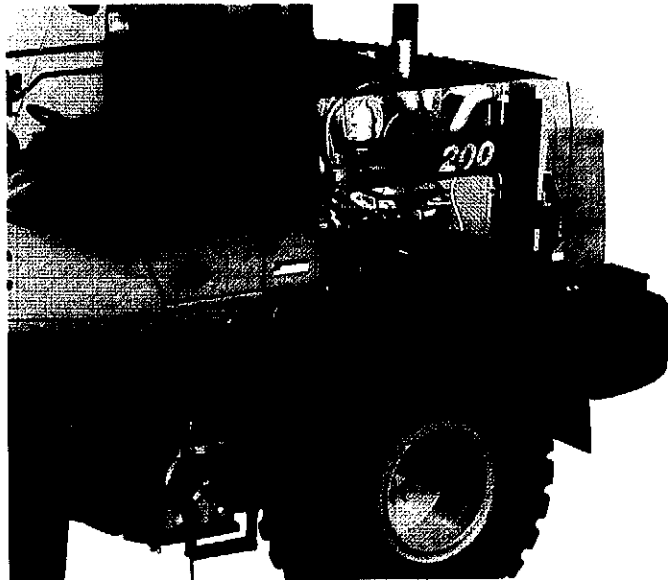

DEF tank

Cab Air Filter

The inside and outside air filters can be replaced easily without the need for tools. The outside filter is located behind a lockable door for security.



Inside air filter

Outside air filter

Maintenance Information

“Maintenance time caution lamp” display

When the time before required maintenance is less than 30 hours*, the maintenance-time monitor appears. Pressing the menu switch displays the maintenance screen.

*: The setting can be changed within the range between 10 and 200 hours.

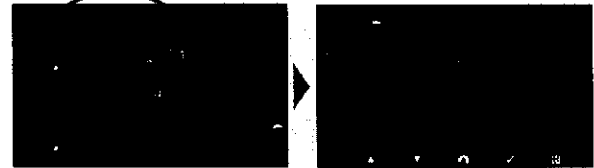

Maintenance screen

Supports DEF level and refill timing

The DEF level gauge is displayed continuously on the monitor panel. In addition, when the refill timing is reached, the DEF-low-level icon appears to alert the operator.



DEF level gauge

DEF low level guidance

Full Rear Fenders (Option)

The WA200-8 has a new rear fender option. The rear fenders open upward and use gas-assist struts, which require low lift force.

The fenders swing up with the gull-wing doors to give the technician easy access to the engine compartment. Mud flaps are also included on the rear fenders.



KOMATSU PARTS & SERVICE SUPPORT



KOMATSU CARE Program Includes:

The WA200-8 comes standard with complimentary factory scheduled maintenance for the first 3 Years or 2,000 Hours, whichever comes first.*

Planned Maintenance Intervals at:

500/1000/1500/2000 hour intervals. (250 hr. initial interval for some products) Complimentary Maintenance Interval includes: Replacement of Oils & Fluid Filters with genuine Komatsu Parts, 50-Point inspection, Komatsu Oil & Wear Analysis Sampling (KOWA) / Travel & Mileage (distance set by distributor; additional charges may apply)

Benefits of Using Komatsu CARE

- Assurance of Proper Maintenance with OEM Parts & Service
- Increased Uptime & Efficiency
- Factory Certified Technicians Performing Work
- Cost of Ownership Savings
- Transferable Upon Resale

Complimentary SCR System Maintenance

The WA200-8 also includes 2 factory recommended services of the Selective Catalytic Reduction (SCR) Diesel exhaust fluid (DEF) system during the first 5 years including: Factory recommended DEF tank flush and strainer cleaning at 4,500 hours and 9,000 hours.

Interval PM	i250	500	1000	1500	2000
CLEAN AC FRESH AND RECIRC AIR FILTERS	✓				
REPLACE HYDRAULIC OIL FILTER ELEMENT	✓				✓
REPLACE HST OIL FILTER	✓		✓		✓
KOWA SAMPLING – (Engine, Front Axle & Rear Axle, Hydraulics, Transfer case)	✓	✓	✓	✓	✓
CHECK AND CLEAN AIR CLEANER	✓	✓	✓	✓	✓
CHECK AND CLEAN FUEL BREATHER ELEMENT	✓	✓	✓	✓	✓
LUBRICATE REAR AXLE PIVOT PIN	✓	✓	✓	✓	✓
LUBRICATE WORK EQUIPMENT	✓	✓	✓	✓	✓
DRAIN SEDIMENT FROM FUEL TANK	✓	✓	✓	✓	✓
COMPLETE 50 POINT INSPECTION FORM; LEAVE PINK COPY WITH CUSTOMER OR IN CAB	✓	✓	✓	✓	✓
RESET MONITOR PANEL MAINTENANCE COUNTER FOR APPROPRIATE ITEMS	✓	✓	✓	✓	✓
CHANGE ENGINE OIL		✓	✓	✓	✓
REPLACE ENGINE OIL FILTER		✓	✓	✓	✓
REPLACE AC FRESH & RECIRC AIR FILTERS		✓	✓	✓	✓
REPLACE FUEL PRE-FILTER		✓	✓	✓	✓
REPLACE FUEL MAIN FILTER			✓		✓
CHANGE OIL IN TRANSFER CASE			✓		✓
CLEAN TRANSFER CASE STRAINER			✓		✓
CLEAN TRANSFER BREATHER			✓		✓
LUBRICATE CENTER HINGE PIN			✓		✓
CHANGE OIL IN HYDRAULIC TANK					✓
REPLACE HYDRAULIC TANK BREATHER ELEMENT					✓
CLEAN HYDRAULIC TANK STRAINER					✓
CHANGE FRONT AND REAR AXLE OIL					✓
CLEAN BRAKE CIRCUIT STRAINER					✓
REPLACE KCCV FILTER					✓
REPLACE HST DRAIN OIL FILTER					✓
REPLACE DEF PUMP FILTER					✓
REPLACE DEF TANK BREATHER					✓
FACTORY TRAINED TECHNICIAN LABOR	✓	✓	✓	✓	✓

2 SCR System Maintenance Services at 4,500 Hrs. and 9000 Hrs.

* Certain exclusions and limitations apply. Refer to the customer certificate for complete program details and eligibility. Komatsu® and Komatsu Care® are registered trademarks of Komatsu Ltd. Copyright 2017 Komatsu America Corp.

Komatsu CARE® – Extended Coverage

- Extended Coverage can provide peace of mind by protecting customers from unplanned expenses that effect cash flow
- Purchasing extended coverage locks-in the cost of covered parts and labor for the coverage period and helps turn these into fixed costs

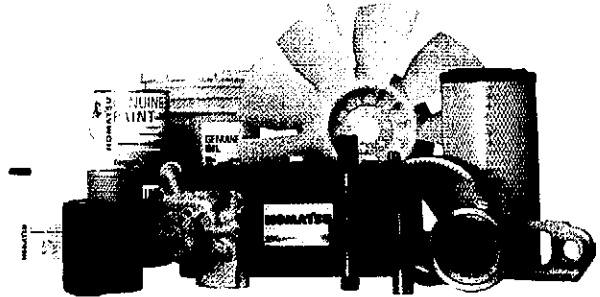

Komatsu Parts Support

- 24/7/365 to fulfill your parts needs
- 9 parts Distribution Centers strategically located across the U.S. and Canada
- Distributor network of more than 300 locations across U.S. and Canada to serve you
- Online part ordering through Komatsu eParts
- Remanufactured components with same-as-new warranties at a significant cost reduction

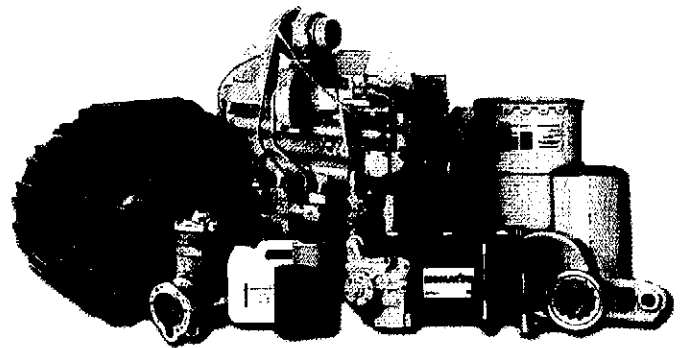

Komatsu Oil and Wear Analysis (KOWA)

- KOWA detects fuel dilution, coolant leaks, and measures wear metals
- Proactively maintain your equipment
- Maximize availability and performance
- Can identify potential problems before they lead to major repairs
- Reduce life cycle cost by extending component life

WA200-8

KOMTRAX EQUIPMENT MONITORING

GET THE WHOLE STORY WITH
KOMTRAX®

✓ **WHAT**

- KOMTRAX is Komatsu's remote equipment monitoring and management system
- KOMTRAX **continuously monitors and records** machine health and operational data
- Information such as fuel consumption, utilization, and a detailed history **lowering owning and operating cost**

✓ **WHEN**

- Know when your machines are **running or idling** and make decisions that will improve your fleet utilization
- Detailed movement records ensure you know when and where your equipment is moved
- Up to date records allow you to **know when maintenance is due** and help you plan for future maintenance needs

✓ **WHERE**

- KOMTRAX data **can be accessed virtually anywhere** through your computer, the web or your smart phone
- Automatic alerts keep fleet managers up to date on the latest machine notifications

✓ **WHO**

- KOMTRAX is **standard** equipment on all Komatsu construction products

✓ **WHY**

- Knowledge is power - **make informed decisions** to manage your fleet better
- Knowing your idle time and fuel consumption will help maximize your machine efficiency
- **Take control of your equipment** - any time, anywhere



KOMTRAX®

For construction and compact equipment.

KOMTRAX Plus®

For production and mining class machines.

SPECIFICATIONS



ENGINE

Model..... Komatsu SAA4D107E-3*
 Type..... Water-cooled, 4-cycle
 Aspiration..... Variable geometry, turbo-charged, after-cooled, cooled EGR
 Number of cylinders..... 4
 Bore..... 107 mm **4.21"**
 Stroke..... 124 mm **4.88"**
 Piston displacement..... 4.46 ltr **272 in³**
 Governor..... All-speed, electronic
 Horsepower:
 SAE J1995..... Gross 95.2 kW **128 HP**
 ISO 9249 / SAE J1349..... Net 94 kW **126 HP**
 Rated rpm..... 2000 rpm
 Fan drive method for radiator cooling..... Hydraulic
 Fuel system..... Direct injection
 Lubrication system:
 Method..... Gear pump, force-lubrication
 Filter..... Full-flow type
 Air cleaner..... Dry type with double elements and dust evacuator, plus dust indicator

*EPA Tier 4 Final emissions certified



TRANSMISSION

Transmission..... Hydrostatic, 1 pump, 2 motors with speed range select

Travel speed	Forward	Reverse
1st	0 - 14.3 km/h 0 - 8.9 mph	0 - 14.3 km/h 0 - 8.9 mph
2nd	14.3 km/h 8.9 mph	14.3 km/h 8.9 mph
3rd	23.2 km/h 14.4 mph	23.2 km/h 14.4 mph
4th	38.0 km/h 23.6 mph	38.0 km/h 23.6 mph

Measured with 20.5-R25 tires



AXLES AND FINAL DRIVES

Drive system..... Four-wheel drive
 Front..... Fixed, semi-floating
 Rear..... Center-pin support, semi-floating, 24° total oscillation
 Reduction gear..... Spiral bevel gear
 Differential gear..... Torque proportioning
 Final reduction gear..... Planetary gear, single reduction



BRAKES

Service brakes..... Hydraulically actuated, wet disc brakes actuate on four wheels
 Parking brake..... Wet, multi-disc brake on transfer output shaft
 Secondary brake..... One of dual service brake circuits is commonly used



STEERING SYSTEM

Type..... Articulated type, fully-hydraulic power steering
 Steering angle..... 38° each direction (40° to max end stop)
 Minimum turning radius at the center of outside tire..... 4880 mm **16' 0"**



HYDRAULIC SYSTEM

Steering system:
 Hydraulic pump..... Gear type pump
 Capacity..... 85 ltr/min **22.5 U.S. gal/min** at rated rpm
 Relief valve setting..... 20.6 MPa 210 kgf/cm² **3,000 psi**
 Hydraulic cylinders:
 Type..... Double-acting, piston type
 Number of cylinders..... 2
 Bore x stroke..... 70 mm x 453 mm **2.76" x 17.8"**
 Loader control:
 Hydraulic pump..... Gear type pump
 Capacity..... 54 ltr/min **14.3 U.S. gal/min** at rated rpm
 Relief valve setting..... 20.6 MPa 210 kgf/cm² **3,000 psi**
 Hydraulic cylinders:
 Type..... Double-acting, piston type
 Number of cylinders—bore x stroke:
 Lift cylinder..... 2- 125 mm x 673.5 mm **4.9" x 26.5"**
 Bucket cylinder..... 1- 150 mm x 504 mm **5.9" x 19.8"**
 Control valve..... 2-spool type
 Control positions:
 Boom..... Raise, hold, lower, and float
 Bucket..... Tilt-back, hold, and dump
 Hydraulic cycle time (rated load in bucket)
 Raise..... 5.7 sec
 Dump..... 1.9 sec
 Lower (Empty)..... 3.2 sec



SERVICE REFILL CAPACITIES

Cooling system..... 26.5 ltr **7.0 U.S. gal**
 Fuel tank..... 177 ltr **46.8 U.S. gal**
 Engine..... 15.5 ltr **4.1 U.S. gal**
 Hydraulic system..... 58 ltr **15.3 U.S. gal**
 Axle front..... 18.5 ltr **4.9 U.S. gal**
 Axle rear..... 18 ltr **4.8 U.S. gal**
 Transfer case..... 5 ltr **1.3 U.S. gal**
 DEF tank..... 14 ltr **3.7 U.S. gal**



BUCKET SELECTION GUIDE

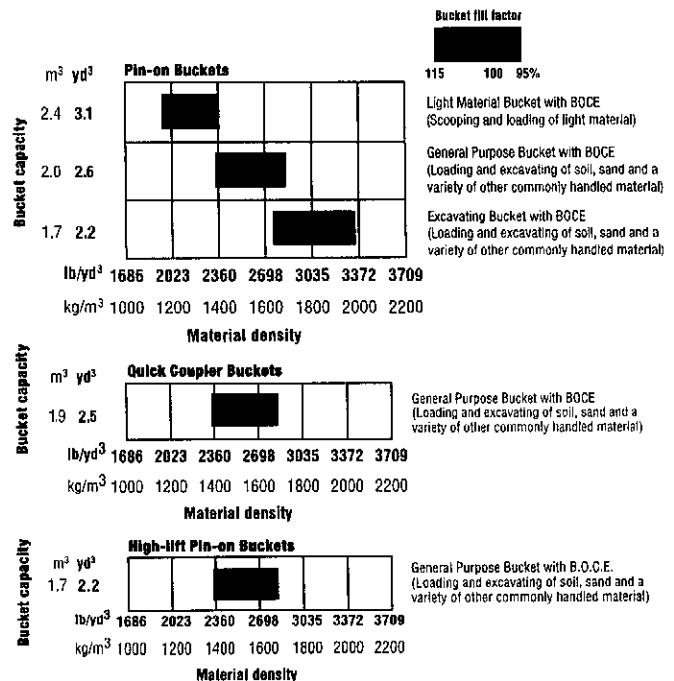



DIMENSIONS

Measured with 20.5-R25(L3) Tires, ROPS/FOPS cab

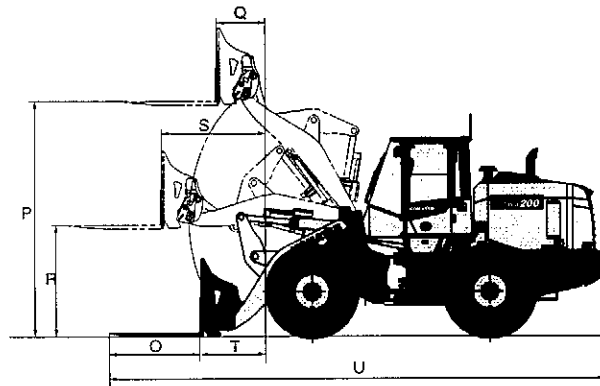
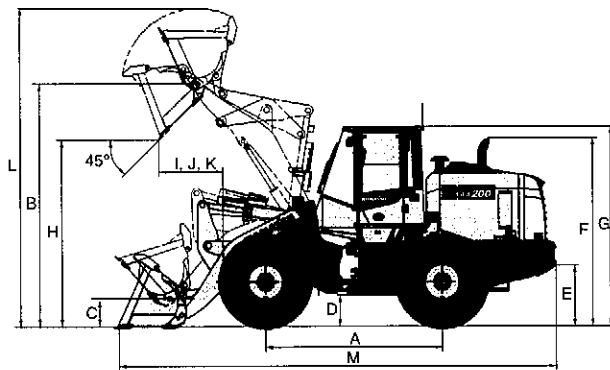

Tread		1930 mm	6'4"
Width over tires		2470 mm	8'1"
A Wheelbase		2840 mm	9'4"
B Hinge pin height, max. height	Standard Boom	3885 mm	12'9"
	High Lift Boom	4325 mm	14'4"

C Hinge pin height, carry position	Standard Boom	425 mm	1'5"
	High Lift Boom	615 mm	2'0"
D Ground clearance		495 mm	1'7"
E Hitch height		965 mm	3'2"
F Overall height, top of the stack		3010 mm	9'10"
G Overall height, ROPS cab		3200 mm	10'6"

BUCKET

	High Lift			
	General Purpose Bucket w/ Pin On	Light Material Bucket w/ Pin On	General Purpose Bucket w/ Quick Coupler	General Purpose Bucket w/ Pin On
	B.O.C.E.	B.O.C.E.	B.O.C.E.	B.O.C.E.
Bucket capacity: heaped	2.0 m ³	2.4 m ³	1.9 m ³	1.7 m ³
	2.6 yd ³	3.1 yd ³	2.5 yd ³	2.2 yd ³
struck	1.7 m ³	2.0 m ³	1.6 m ³	1.4 m ³
	2.2 yd ³	2.6 yd ³	2.1 yd ³	1.8 yd ³
Bucket width	2550 mm	2550 mm	2550 mm	2550 mm
	8'4"	8'4"	8'4"	8'4"
Bucket weight	890 kg	965 kg	885 kg	825 kg
	1,926 lb	2,127 lb	1,951 lb	1,819 lb
H Dumping clearance, max. height and 45° dump angle*	2965 mm	2875 mm	2810 mm	3480 mm
	9'8"	9'5"	9'3"	11'5"
I Reach at max. height and 45° dump angle*	950 mm	1035 mm	1075 mm	940 mm
	3'1"	3'5"	3'6"	3'1"
J Reach at 2130 mm 7° clearance and 45° dump angle*	1580 mm	1625 mm	1630 mm	1965 mm
	5'2"	5'4"	5'4"	6'5"
K Reach with arm horizontal and bucket level*	2315 mm	2440 mm	2515 mm	2600 mm
	7'7"	8'0"	8'3"	8'6"
L Operating height (fully raised)	5095 mm	5215 mm	5220 mm	5430 mm
	16'8"	17'1"	17'2"	17'10"
M Overall length (bucket on ground)	7130 mm	7255 mm	7350 mm	7515 mm
	23'4"	23'10"	24'1"	24'8"
Loader clearance circle (bucket at carry, outside corner of bucket)	11860 mm	11930 mm	11965 mm	12205 mm
	38'11"	39'2"	39'3"	40'1"
Digging depth: 0°	110 mm	110 mm	120 mm	195 mm
	4"	4"	5"	8"
10°	295 mm	320 mm	340 mm	360 mm
	12"	13"	13"	14"
Static tipping load: straight	8725 kg	8650 kg	8525 kg	7075 kg
	19,235 lb	19,070 lb	18,794 lb	15,598 lb
40° full turn	7645 kg	7570 kg	7450 kg	6150 kg
	16,854 lb	16,689 lb	16,424 lb	13,558 lb
Breakout force	108 kN	107 kN	96 kN	125 kN
	11000 kgf	10920 kgf	9755 kg	12700 kg
	24,251 lb	24,075 lb	21,506 lb	27,999 lb
Operating weight	11715 kg	11790 kg	12015 kg	11875 kg
	25,827 lb	25,993 lb	26,489 lb	26,180 lb

* At the end of tooth or B.O.C.E.

All dimensions, weights, and performance values based on ISO 7131, ISO 14397-1 and ISO 7546 standards. Static tipping load and operating weight shown include lubricant, coolant, full fuel tank, ROPS cab and operator. Machine stability and operating weight affected by tire size and attachments.

FORK

	Fork With Quick Coupler
O Fork tine length	1220 mm
	4'0"
P Ground to top of tine at maximum lift	3740 mm
	12'3"
Q Reach at maximum lift	810 mm
	2'8"
R Ground to top of tine - boom and tine level	1750 mm
	5'9"
S Reach - boom and tine level	1715 mm
	5'8"
T Reach - tine level on ground	1110 mm
	3'8"
U Overall length - tine level on ground	7775 mm
	25'6"
Static tipping load - boom level: straight	6095 kg
fork level, tine center	13,437 lb
40° full turn	5340 kg
	11,773 lb
Operating weight	11705 kg
	25,805 lb

Operating load per SAE J1197 (Oct, 2011), 50% of static tipping load.

Static tipping load and operating weight shown include lubricant, coolant, full fuel tank, ROPS cab and operator. Machine stability and operating weight affected by tire size and attachments.



WEIGHT CHANGES

Tires or attachments	Change in operating weight		Change in tipping load				Width over tires		Ground clearance		Change in vertical dimensions	
			Straight		Full turn							
	kg	lb	kg	lb	kg	lb	mm	ft in	mm	ft in	mm	ft in
17.5-25-12PR (L2)	-610	-1345	-405	-893	-405	-893	2375	7'10"	425	1'5"	-70	-3"
20.5-R25 (L2)	+40	+88	+25	+55	+25	+55	2470	8'1"	495	1'7"	0	0



STANDARD EQUIPMENT

- 2-spool valve for boom and bucket control
- Alternator, 24 V/ 90 A
- Automatic hydraulic-driven fan with automatic reverse rotation
- Back-up alarm
- Batteries, 92 Ah/12V (2), 680 CCA
- Battery disconnect
- Boom kick-out, in-cab adjustable
- Bucket positioner
- Color, rear-view camera and monitor
- Counterweight, standard
- Electronically Controlled Suspension System
- Engine, Komatsu SAA4D107E-3 diesel
- Engine shut-off system, electric
- Equipment Management Monitoring System (EMMS)
 - Lights (central warning, brake oil pressure, engine oil pressure, parking brake, cooling fan reverse, DPF restriction, seat belt caution, Komtrax message)
 - Gauges (DEF level, engine coolant temperature, ecology, fuel level, HST oil temperature, speedometer/tachometer), variable speed display
- Front fenders
- Fuel pre-filter with water separator
- Horn, electric
- Hydrostatic transmission
- Komatsu Auto Idle Shutdown
- KOMTRAX® Level 5
- Lift cylinders and bucket cylinder
- Lights
 - Back-up light
 - Stop and tail light
 - Turn signal lamps, 2 front and 2 rear with hazard switch
 - Working lights, halogen, 2 front cab mount
 - Working lights, halogen, 2 front fender mount
 - Working lights, halogen, 2 rear grill mount
- Loader linkage with standard lift arm
- Multifunction mono-lever loader control with transmission F/R switch
- Parking brake, electric
- Radiator, wider core
- Radiator mask, swing up
- Rear view mirrors, outside (2) inside (2)
- Rims for 20.5-R25 tires
- ROPS/FOPS Cab Level 2
 - 2 x DC12V electrical outlets
 - Ashtray
 - Auto air conditioner
 - Cigarette lighter, 24V
 - Color LCD/TFT multi-monitor
 - Cup holder
 - Floor mat
 - Operator seat, reclining, air suspension type, heated
 - Radio, AM/FM with AUX input jack
 - Rear defroster, electric
 - Seatbelt, 2-point retractable, 76mm 3" width
 - Space for lunch box
 - Steering wheel, tilt and telescopic
 - Sun visor, front window
 - Windshield washer and wiper, front with intermittent
 - Windshield washer and wiper, rear
- Service brakes, wet disc type
- Starting motor, 5.5 kW
- Transmission speed ranges, 4 forward and 4 reverse
- Vandalism protection kit, padlocks for battery box (2)



OPTIONAL EQUIPMENT

- Three-spool valve (will utilize integrated proportional control switch included in the multi-function mono-lever) and piping
- Auxiliary steering (SAE)
- Centrifugal engine air pre-cleaner
- Cutting edge (bolt-on type)
- Full rear fenders
- High lift boom
- Limited slip differential (F&R)
- Quick coupler
- Various tire options, radial and bias
- Various bucket and fork options

AESS920-03

©2018 Komatsu America Corp.

Printed in USA

AD05(1.5M)OTP

05/18 (EV-1)

KOMATSU®

Note: All comparisons and claims of improved performance made herein are made with respect to the prior Komatsu model unless otherwise specifically stated.