

RECEIVED

STATE OF WEST VIRGINIA
Purchasing Division

2020 MAR -3 AM 10:03

PURCHASING AFFIDAVIT

WV PURCHASING
DIVISION

CONSTRUCTION CONTRACTS: Under W. Va. Code § 5-22-1(i), the contracting public entry shall not award a construction contract to any bidder that is known to be in default on any monetary obligation owed to the state or a political subdivision of the state, including, but not limited to, obligations related to payroll taxes, property taxes, sales and use taxes, fire service fees, or other fines or fees.

ALL OTHER CONTRACTS: Under W. Va. Code §5A-3-10a, no contract or renewal of any contract may be awarded by the state or any of its political subdivisions to any vendor or prospective vendor when the vendor or prospective vendor or a related party to the vendor or prospective vendor is a debtor and: (1) the debt owed is an amount greater than one thousand dollars in the aggregate; or (2) the debtor is in employer default.

EXCEPTION: The prohibition listed above does not apply where a vendor has contested any tax administered pursuant to chapter eleven of the W. Va. Code, workers' compensation premium, permit fee or environmental fee or assessment and the matter has not become final or where the vendor has entered into a payment plan or agreement and the vendor is not in default of any of the provisions of such plan or agreement.

DEFINITIONS:

"Debt" means any assessment, premium, penalty, fine, tax or other amount of money owed to the state or any of its political subdivisions because of a judgment, fine, permit violation, license assessment, defaulted workers' compensation premium, penalty or other assessment presently delinquent or due and required to be paid to the state or any of its political subdivisions, including any interest or additional penalties accrued thereon.

"Employer default" means having an outstanding balance or liability to the old fund or to the uninsured employers' fund or being in policy default, as defined in W. Va. Code § 23-2c-2, failure to maintain mandatory workers' compensation coverage, or failure to fully meet its obligations as a workers' compensation self-insured employer. An employer is not in employer default if it has entered into a repayment agreement with the Insurance Commissioner and remains in compliance with the obligations under the repayment agreement.

"Related party" means a party, whether an individual, corporation, partnership, association, limited liability company or any other form or business association or other entity whatsoever, related to any vendor by blood, marriage, ownership or contract through which the party has a relationship of ownership or other interest with the vendor so that the party will actually or by effect receive or control a portion of the benefit, profit or other consideration from performance of a vendor contract with the party receiving an amount that meets or exceeds five percent of the total contract amount.

AFFIRMATION: By signing this form, the vendor's authorized signer affirms and acknowledges under penalty of law for false swearing (W. Va. Code §61-5-3) that: (1) for construction contracts, the vendor is not in default on any monetary obligation owed to the state or a political subdivision of the state, and (2) for all other contracts, that neither vendor nor any related party owe a debt as defined above and that neither vendor nor any related party are in employer default as defined above, unless the debt or employer default is permitted under the exception above.

WITNESS THE FOLLOWING SIGNATURE:

Vendor's Name: PBE, INCORPORATED

Authorized Signature: [Signature] Date: 3/2/2020

State of Virginia

County of Henrico, to-wit:

Taken, subscribed, and sworn to before me this 2 day of March, 2020

My Commission expires 3-31, 2022

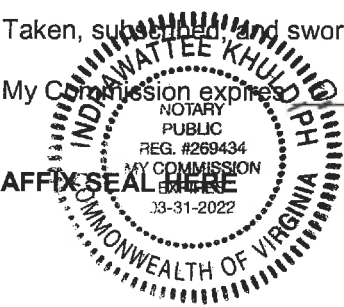

NOTARY PUBLIC [Signature]



Purchasing Division
 2019 Washington Street East
 Post Office Box 50130
 Charleston, WV 25305-0130

State of West Virginia
 Request for Quotation
 13 – Equipment

Proc Folder: 661013

Doc Description: Addendum No.2 - Recycling Baler (Horizontal)

Proc Type: Central Purchase Order

Date Issued	Solicitation Closes	Solicitation No	Version
2020-02-24	2020-03-04 13:30:00	CRFQ 0603 ADJ2000000013	3

BID RECEIVING LOCATION

BID CLERK
 DEPARTMENT OF ADMINISTRATION
 PURCHASING DIVISION
 2019 WASHINGTON ST E
 CHARLESTON WV 25305
 US

VENDOR

Vendor Name, Address and Telephone Number:

PBE INCORPORATED
 611 MOOREFIELD PARK DR
 N. CHESTERFIELD, VA 23236
 (804) 323-3519

FOR INFORMATION CONTACT THE BUYER

John W Estep
 (304) 558-7839
 john.w.estep@wv.gov

Signature X 

FEIN # 570570555

DATE 3/2/2020

All offers subject to all terms and conditions contained in this solicitation

ADDITIONAL INFORMATION:

Addendum No.2 is Issued to:

1. Respond to Vendor Question per attached .
2. Modify Bid opening Date

No Other Changes

INVOICE TO		SHIP TO	
DIVISION ENGINEERING & FACILITIES ADJUTANT GENERALS OFFICE 1707 COONSKIN DR		304-675-3950 ADJUTANT GENERALS OFFICE POINT PLEASANT ARMORY - TIRE REBUILD SHOP 4194 OHIO RIVER ROAD	
CHARLESTON	WV25311	POINT PLEASANT	WV 25550
US		US	

Line	Comm Ln Desc	Qty	Unit Issue	Unit Price	Total Price
1	Recycling Baler (Horizontal)	0.00000	EA		

Comm Code	Manufacturer	Specification	Model #
21101709	MAX PAK	CLOSED DOOR MANUAL FULL EJECT BALER HORIZONTAL/ w CONVEYOR	HCE60FE-8

Extended Description :

Recycling Baler (Horizontal)
including inside delivery, assembly, and training for the agency on operation and maintenance of the machine.

SCHEDULE OF EVENTS

Line	Event	Event Date
1	Technical Questions due by 10:00am	2020-02-20

ADJ200000013	Document Phase Final	Document Description Addendum No.2 - Recycling Baler (Horizontal)	Page 3 of 3
---------------------	--------------------------------	---	------------------------------

ADDITIONAL TERMS AND CONDITIONS

See attached document(s) for additional Terms and Conditions

DESIGNATED CONTACT: Vendor appoints the individual identified in this Section as the Contract Administrator and the initial point of contact for matters relating to this Contract.

 , President
(Name, Title)
Rob Lamoree, President
(Printed Name and Title)
611 MOOREFIELD PARK DR N. CHESTERFIELD, VA 23236
(Address)
ph (804) 323-3519 fx (804) 320-2502
(Phone Number) / (Fax Number)
rlamoree @ pbe-usa.com
(email address)

CERTIFICATION AND SIGNATURE: By signing below, or submitting documentation through wvOASIS, I certify that I have reviewed this Solicitation in its entirety; that I understand the requirements, terms and conditions, and other information contained herein; that this bid, offer or proposal constitutes an offer to the State that cannot be unilaterally withdrawn; that the product or service proposed meets the mandatory requirements contained in the Solicitation for that product or service, unless otherwise stated herein; that the Vendor accepts the terms and conditions contained in the Solicitation, unless otherwise stated herein; that I am submitting this bid, offer or proposal for review and consideration; that I am authorized by the vendor to execute and submit this bid, offer, or proposal, or any documents related thereto on vendor's behalf; that I am authorized to bind the vendor in a contractual relationship; and that to the best of my knowledge, the vendor has properly registered with any State agency that may require registration.

PBE, INCORPORATED
(Company)
 , President
(Authorized Signature) (Representative Name, Title)
Rob Lamoree, President
(Printed Name and Title of Authorized Representative)
3/2/2020
(Date)
ph (804) 323-3519 fx (804) 320-2502
(Phone Number) (Fax Number)



PBEINC0-01

NDCORRY

CERTIFICATE OF LIABILITY INSURANCE

DATE (MM/DD/YYYY)
2/28/2020

THIS CERTIFICATE IS ISSUED AS A MATTER OF INFORMATION ONLY AND CONFERS NO RIGHTS UPON THE CERTIFICATE HOLDER. THIS CERTIFICATE DOES NOT AFFIRMATIVELY OR NEGATIVELY AMEND, EXTEND OR ALTER THE COVERAGE AFFORDED BY THE POLICIES BELOW. THIS CERTIFICATE OF INSURANCE DOES NOT CONSTITUTE A CONTRACT BETWEEN THE ISSUING INSURER(S), AUTHORIZED REPRESENTATIVE OR PRODUCER, AND THE CERTIFICATE HOLDER.

IMPORTANT: If the certificate holder is an **ADDITIONAL INSURED**, the policy(ies) must have **ADDITIONAL INSURED** provisions or be endorsed. If **SUBROGATION IS WAIVED**, subject to the terms and conditions of the policy, certain policies may require an endorsement. A statement on this certificate does not confer rights to the certificate holder in lieu of such endorsement(s).

PRODUCER Towne Insurance Agency, LLC 9330 Iron Bridge Road Suite A Chesterfield, VA 23832		CONTACT NAME: Vera S. Ligon PHONE (A/C, No, Ext): (804) 751-0600 E-MAIL ADDRESS: vligon@towneinsurance.com FAX (A/C, No):	
		INSURER(S) AFFORDING COVERAGE	
		NAIC #	
		INSURER A : Owners Insurance Company	
		INSURER B : Auto-Owners Insurance Company	
		INSURER C :	
		INSURER D :	
		INSURER E :	
		INSURER F :	
INSURED PBE, Inc. P O Box 35698 Richmond, VA 23236			

COVERAGES CERTIFICATE NUMBER: REVISION NUMBER:

THIS IS TO CERTIFY THAT THE POLICIES OF INSURANCE LISTED BELOW HAVE BEEN ISSUED TO THE INSURED NAMED ABOVE FOR THE POLICY PERIOD INDICATED. NOTWITHSTANDING ANY REQUIREMENT, TERM OR CONDITION OF ANY CONTRACT OR OTHER DOCUMENT WITH RESPECT TO WHICH THIS CERTIFICATE MAY BE ISSUED OR MAY PERTAIN, THE INSURANCE AFFORDED BY THE POLICIES DESCRIBED HEREIN IS SUBJECT TO ALL THE TERMS, EXCLUSIONS AND CONDITIONS OF SUCH POLICIES. LIMITS SHOWN MAY HAVE BEEN REDUCED BY PAID CLAIMS.

INSR LTR	TYPE OF INSURANCE	ADDL SUBR INSD. WVD	POLICY NUMBER	POLICY EFF (MM/DD/YYYY)	POLICY EXP (MM/DD/YYYY)	LIMITS
A	<input checked="" type="checkbox"/> COMMERCIAL GENERAL LIABILITY <input type="checkbox"/> CLAIMS-MADE <input checked="" type="checkbox"/> OCCUR GEN'L AGGREGATE LIMIT APPLIES PER: <input type="checkbox"/> POLICY <input checked="" type="checkbox"/> PROJECT <input checked="" type="checkbox"/> LOC OTHER:		43386231	9/2/2019	9/2/2020	EACH OCCURRENCE \$ 1,000,000 DAMAGE TO RENTED PREMISES (Ea occurrence) \$ 300,000 MED EXP (Any one person) \$ 10,000 PERSONAL & ADV INJURY \$ 1,000,000 GENERAL AGGREGATE \$ 3,000,000 PRODUCTS - COMP/OP AGG \$ 3,000,000 HIRED NON OWNED \$ 1,000,000
B	AUTOMOBILE LIABILITY <input checked="" type="checkbox"/> ANY AUTO OWNED AUTOS ONLY <input checked="" type="checkbox"/> HIRED AUTOS ONLY <input type="checkbox"/> SCHEDULED AUTOS <input checked="" type="checkbox"/> NON-OWNED AUTOS ONLY		5138623101	9/2/2019	9/2/2020	COMBINED SINGLE LIMIT (Ea accident) \$ 1,000,000 BODILY INJURY (Per person) \$ BODILY INJURY (Per accident) \$ PROPERTY DAMAGE (Per accident) \$
A	<input checked="" type="checkbox"/> UMBRELLA LIAB <input checked="" type="checkbox"/> OCCUR <input type="checkbox"/> EXCESS LIAB <input type="checkbox"/> CLAIMS-MADE DED <input checked="" type="checkbox"/> RETENTION \$ 10,000		5138623100	9/2/2019	9/2/2020	EACH OCCURRENCE \$ 4,000,000 AGGREGATE \$ 4,000,000
B	WORKERS COMPENSATION AND EMPLOYERS' LIABILITY ANY PROPRIETOR/PARTNER/EXECUTIVE OFFICER/MEMBER EXCLUDED? (Mandatory in NH) If yes, describe under DESCRIPTION OF OPERATIONS below Y/N <input checked="" type="checkbox"/> N/A		43084138	9/2/2019	9/2/2020	<input checked="" type="checkbox"/> PER STATUTE <input type="checkbox"/> OTHER E.L. EACH ACCIDENT \$ 1,000,000 E.L. DISEASE - EA EMPLOYEE \$ 1,000,000 E.L. DISEASE - POLICY LIMIT \$ 1,000,000
B	Installation Floater		43386231	9/2/2019	9/2/2020	Ded. \$2,500 300,000

DESCRIPTION OF OPERATIONS / LOCATIONS / VEHICLES (ACORD 101, Additional Remarks Schedule, may be attached if more space is required)
 The Umbrella coverage extends liability limits to General Liability, Business Automobile and Employees Liability/Workers Compensation policies.

CERTIFICATE HOLDER

WV Army National Guard
 1707 Coonskin Dr
 Charleston, WV 25311

CANCELLATION

SHOULD ANY OF THE ABOVE DESCRIBED POLICIES BE CANCELLED BEFORE THE EXPIRATION DATE THEREOF, NOTICE WILL BE DELIVERED IN ACCORDANCE WITH THE POLICY PROVISIONS.

AUTHORIZED REPRESENTATIVE
Vera S. Ligon

SOLICITATION NUMBER: CRFQ ADJ2000000013
Addendum Number: 2

The purpose of this addendum is to modify the solicitation identified as CRFQ ADJ2000000013 ("Solicitation") to reflect the change(s) identified and described below.

Applicable Addendum Category:

- Modify bid opening date and time
- Modify specifications of product or service being sought
- Attachment of vendor questions and responses
- Attachment of pre-bid sign-in sheet
- Correction of error
- Other-

Additional Documentation:

1. Responses to Vendor Questions
2. The bid opening changes to 03/04/2020 at 1:30 pm.

Terms and Conditions:

1. All provisions of the Solicitation and other addenda not modified herein shall remain in full force and effect.
2. Vendor should acknowledge receipt of all addenda issued for this Solicitation by completing an Addendum Acknowledgment, a copy of which is included herewith. Failure to acknowledge addenda may result in bid disqualification. The addendum acknowledgement should be submitted with the bid to expedite document processing.

Vendor Questions-PART 2- for CRFQ 0603 ADJ2000000013
Recycling Baler (Horizontal)

1. Couple question on this solicitation, you want to conveyor feed the baler correct? See attached brochure on our horizontal baler, will the set up in the picture (second page) work for your location?

Answer) Yes, we do want to conveyor feed the baler. Yes, that configuration will work in our Location.

2. What commodity are you needing to bale? Cardboard only?

Answer) Cardboard, paper and eventually plastic.

3. What are you looking to bale?

Answer) Cardboard and paper, then eventually plastic.

4. You call out a electric conveyor in the spec, but it appears to be a bit confusing. Even the model you are calling out when you add the rear feed conveyor is almost 27' long. What are you asking for here (conveyor over the rear, pit conveyor, etc.)?

Answer) We can go up to 30 feet in length if we need to but wish to stay around 27ft in total (baler and conveyor combined) once the machine is set-up.

5. Is this space heated and indoor? If not, we strongly recommend a tank oil heater?

Answer) Space is indoors and is currently heated well.

6. Are you willing to accept a machine with 150,800lbs force as this is the common machine we sell to municipalities?

Answer) Yes, if that machine meets all other mandatory requirements called for in the specification.

7. Just confirming you need 230 volt, 3Phase power set-up?

Answer) Yes, See Section 3.1.1.1 for details.

ADDENDUM ACKNOWLEDGEMENT FORM
SOLICITATION NO.: CRFO ADJ200000013

Instructions: Please acknowledge receipt of all addenda issued with this solicitation by completing this addendum acknowledgment form. Check the box next to each addendum received and sign below. Failure to acknowledge addenda may result in bid disqualification.

Acknowledgment: I hereby acknowledge receipt of the following addenda and have made the necessary revisions to my proposal, plans and/or specification, etc.

Addendum Numbers Received:

(Check the box next to each addendum received)

- | | |
|--|--|
| <input type="checkbox"/> Addendum No. 1 | <input type="checkbox"/> Addendum No. 6 |
| <input checked="" type="checkbox"/> Addendum No. 2 | <input type="checkbox"/> Addendum No. 7 |
| <input type="checkbox"/> Addendum No. 3 | <input type="checkbox"/> Addendum No. 8 |
| <input type="checkbox"/> Addendum No. 4 | <input type="checkbox"/> Addendum No. 9 |
| <input type="checkbox"/> Addendum No. 5 | <input type="checkbox"/> Addendum No. 10 |

I understand that failure to confirm the receipt of addenda may be cause for rejection of this bid. I further understand that that any verbal representation made or assumed to be made during any oral discussion held between Vendor's representatives and any state personnel is not binding. Only the information issued in writing and added to the specifications by an official addendum is binding.

PBE, INCORPORATED

Company



Authorized Signature

2/28/2020

Date

NOTE: This addendum acknowledgment should be submitted with the bid to expedite document processing.

SOLICITATION NUMBER: CRFQ ADJ2000000013

Addendum Number: 1

The purpose of this addendum is to modify the solicitation identified as CRFQ ADJ2000000013 ("Solicitation") to reflect the change(s) identified and described below.

Applicable Addendum Category:

- Modify bid opening date and time
- Modify specifications of product or service being sought
- Attachment of vendor questions and responses
- Attachment of pre-bid sign-in sheet
- Correction of error
- Other-

Additional Documentation:

1. Responses to Vendor Questions
2. The bid opening remains on 02/28/2020 at 1:30 pm.

Terms and Conditions:

1. All provisions of the Solicitation and other addenda not modified herein shall remain in full force and effect.
2. Vendor should acknowledge receipt of all addenda issued for this Solicitation by completing an Addendum Acknowledgment, a copy of which is included herewith. Failure to acknowledge addenda may result in bid disqualification. The addendum acknowledgement should be submitted with the bid to expedite document processing.

**Vendor Questions for CRFQ 0603 ADJ2000000013
Recycling Baler (Horizontal)**

1. The HE-60 model is 120,600 with maximum 140,800lbs platen force. Is this acceptable?

Answer) Yes.

2. The HW-60 length is 28' long. Is this acceptable?

Answer) Yes, a 28' length machine will fit in the agency location.

3. To manufacture, deliver and install this baler will take a minimum of 12 weeks from the time we receive your signed PO. Is this acceptable?

Answer) Yes, this is an acceptable timeframe for the agency.

4. Is any leniency given for a justifiable delay?

Answer) Yes, the agency understands that production/raw materials/manufacturing delays can happen when a machine of this type is built after an order is placed. There are no liquidated damages or penalties in this contract.

ADDENDUM ACKNOWLEDGEMENT FORM
SOLICITATION NO.: CRFO ADJ2000000013

Instructions: Please acknowledge receipt of all addenda issued with this solicitation by completing this addendum acknowledgment form. Check the box next to each addendum received and sign below. Failure to acknowledge addenda may result in bid disqualification.

Acknowledgment: I hereby acknowledge receipt of the following addenda and have made the necessary revisions to my proposal, plans and/or specification, etc.

Addendum Numbers Received:

(Check the box next to each addendum received)

- | | |
|--|--|
| <input checked="" type="checkbox"/> Addendum No. 1 | <input type="checkbox"/> Addendum No. 6 |
| <input type="checkbox"/> Addendum No. 2 | <input type="checkbox"/> Addendum No. 7 |
| <input type="checkbox"/> Addendum No. 3 | <input type="checkbox"/> Addendum No. 8 |
| <input type="checkbox"/> Addendum No. 4 | <input type="checkbox"/> Addendum No. 9 |
| <input type="checkbox"/> Addendum No. 5 | <input type="checkbox"/> Addendum No. 10 |

I understand that failure to confirm the receipt of addenda may be cause for rejection of this bid. I further understand that that any verbal representation made or assumed to be made during any oral discussion held between Vendor's representatives and any state personnel is not binding. Only the information issued in writing and added to the specifications by an official addendum is binding.

PBE, INCORPORATED

Company



Authorized Signature

2/28/2020

Date

NOTE: This addendum acknowledgement should be submitted with the bid to expedite document processing.

Exhibit A Pricing Page
Baler for Recycling Program

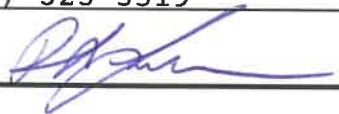
ITEM	DESCRIPTION	Each	UNIT PRICE	Extended Total
1	Closed Door Manual Tie Full Eject Horizontal Baler	1	\$99,500.00	\$99,500.00
	MAX PAK HCE60FE-8 w/ CONVEYOR			
	Includes:			
	220 Volt			
	Oil Cooler			
	Oil			
	Freight			
	Installation			
	Start Up & Training			
	* Does NOT Include Bringing Power to System			
Vendor Name: PBE, INCORPORATED Address: 611 MOOREFIELD PARK DR N. CHESTERFIELD, VA 23236 Phone: (804) 323-3519 Fax: (804) 320-2502 Authorized Signature:  Date: 3/2/2020				
Failure to use this bid form may result in disqualification.				



Model: HCE60FE-8

General Specifications - Revised: 11-Jan-17

*Bale Size / Density / Capacity / Performance Data:

Bale Size: 48" x 30" x 60"
Bale Volume: 50 Cubic Feet
Cycle Time: 29.58 Seconds - (No Load/Full Stroke)
Capacity: 6,038 Cubic Feet per Hour - (No Load / 65% L.E.)

Material	Bale Weight	Density:	Bales / Hour
		Lbs. / FT ³ - Loose / Baled	(Assuming 65% Labor Efficiency & Wire Tying)
Bulk OCC	Up to 1300 lbs.	2.5 / 28	Up to 3
Cond. News / OM	Up to 1450 lbs.	3 / 30	Up to 3
Perforated PET	Up to 900 lbs.	1.5 / 18	Up to 3
UBC	Up to 750 lbs.	1 / 15	Up to 3

*Performance Rates, Bale Weights and Densities are subject to variables such as Moisture Content, Loose Densities, Feed Rates, and other variables associated with the process of baling.

Recommended Bale Wire: 12ga, 16" Single Loop - 5/bale

Shipping Weight: 26,000lbs

Hydraulic Components and Data:

Main Pump: Horsepower Limited Piston - 60gpm
Main Cylinder: 8" Bore, 89" Stroke, 5.5" Rod - Clevis Mount
Door Clamp Cylinder: 5" Bore, 10" Stroke, 2.5" Rod - Clevis Mount
System Pressure: 3,000 psi
Operating Pressure: 2,850 psi
Ram Face Pressure: 83.73 psi
Overall Platen Force: 143,256 lbs.
Oil Reservoir: 150 Gallons
Main Hydraulic Manifold: CETOP 8 - High Flow Directional Valves
Filtration: 5 Micron Absolute

Mechanical Systems Data:

Stationary Shear Blade: Replaceable AR400 Alloy Steel - 4-sided turnable
Platen Shear Blade: Replaceable AR400 Alloy Steel - Serrated - 2 Sided Turnable
Platen Guide: Replaceable HDPE Guide System
 Tongue and Groove Floor Configuration w/ Matching Platen Base

Electrical Components and Data:

Main Motor: 30hp TEFC, Premium Efficiency, 208/230/460v - 3ph
Controls: Allen Bradley Micrologix 1400 PLC- Ethernet Ready,
 Touch Screen Interface, Internal Panel Heater, UL & CUL Listed,
 Selectable Photo-Eyes (Primary or Alternate), Standard
 Across-The-Line Starting

Structural Data:

Frame: Heavy Channel and Tube Steel Construction
Floor & Platen: Replaceable AR400 Alloy Steel Wear Surfaces
Subfloor: Heavy Wall Tube Steel in "Honey-Comb" design for
 Superior Strength

Optional Equipment and Features:

Reduced Amperage Starting	Feed Hopper Extension
Remote Power Unit and/or Operator Station	Upper Photo-Eyes
Ultrasonic or High Intensity Actuators	Custom Paint
Oil Heater	Conveyor and/or Conveyor Controls
Regenerative Hydraulics	Flame Retardant Hydraulic Oil
	Oil Cooler

8 | 7 | 6 | 5 | 4 | 3 | 2 | 1

THIS BALER REQUIRES 5' OF
CLEARANCE ON ALL SIDES.

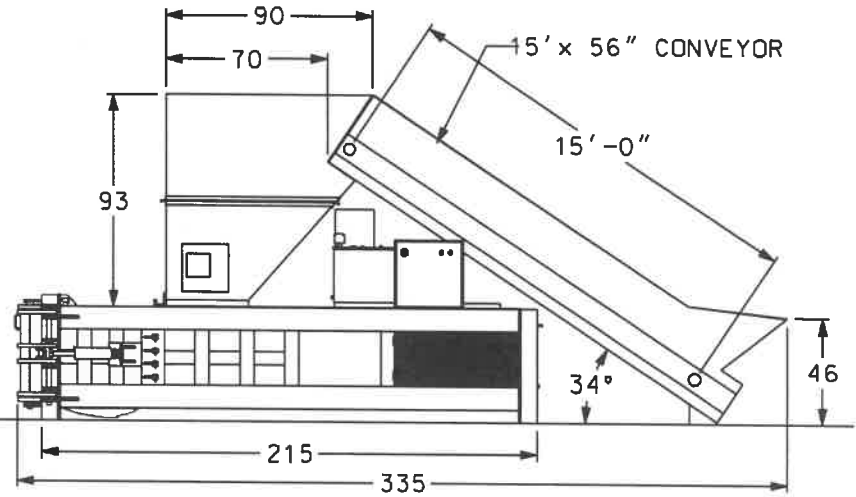
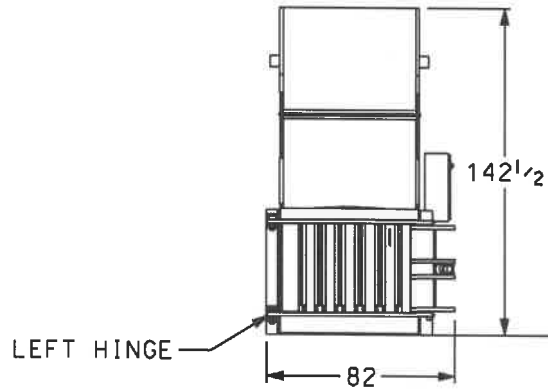
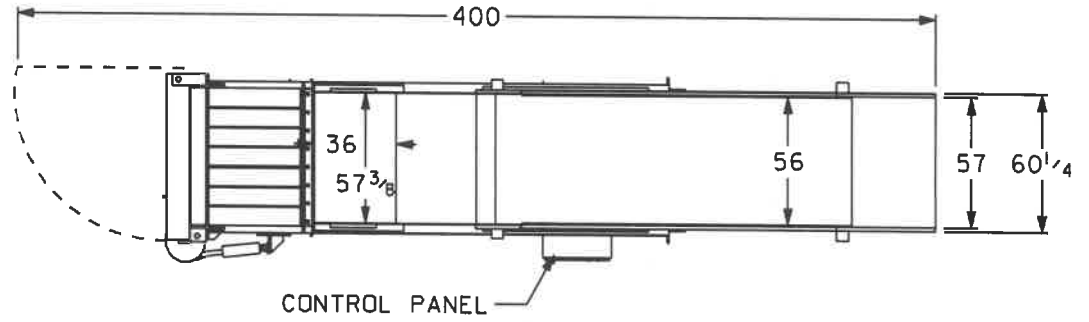

DIMENSIONS SUBJECT TO ENGINEERING CHANGES.

THIS DRAWING IS THE EXCLUSIVE PROPERTY OF WASTE PROCESSING EQUIPMENT, INC. ITS ACCEPTANCE CONSTITUTES AN AGREEMENT THAT IT SHALL BE TREATED AS A STRICTLY CONFIDENTIAL DOCUMENT AND IS NOT TO BE COMMUNICATED, DISCLOSED, OR COPIED UNLESS AUTHORIZED BY WASTE PROCESSING EQUIPMENT, INC.

COMPANY NAME: _____
 APPROVED BY: _____
 DATE: _____
 VOLTAGE/PHASE: _____
 RETURN TO: WASTE PROCESSING EQUIPMENT, INC.
 FAX# (256)-638-8979

NOT FOR APPROVAL

UNLESS OTHERWISE SPECIFIED,
 DIMENSIONS ARE IN INCHES
 TOLERANCES

±1" NOMINAL

APPROVALS	DATE
DRAWN GT	1/30/13
CHECK	
ENGR	

	WASTE PROCESSING EQUIPMENT, INC. 260 DILBECK ROAD, P.O. BOX 1047 RAINSVILLE, ALABAMA 35986
	TITLE HCE 60FE-8 SYSTEM CONCEPTUAL DRAWING
DWG. NO. HCE60FE-8 SYSTEM-LH	

A

A

THIS BALER REQUIRES 5' OF
CLEARENCE ON ALL SIDES.

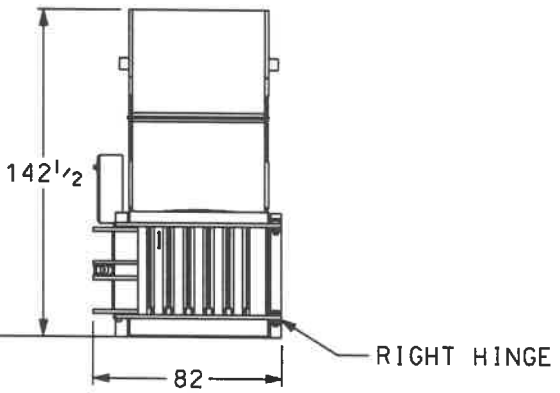
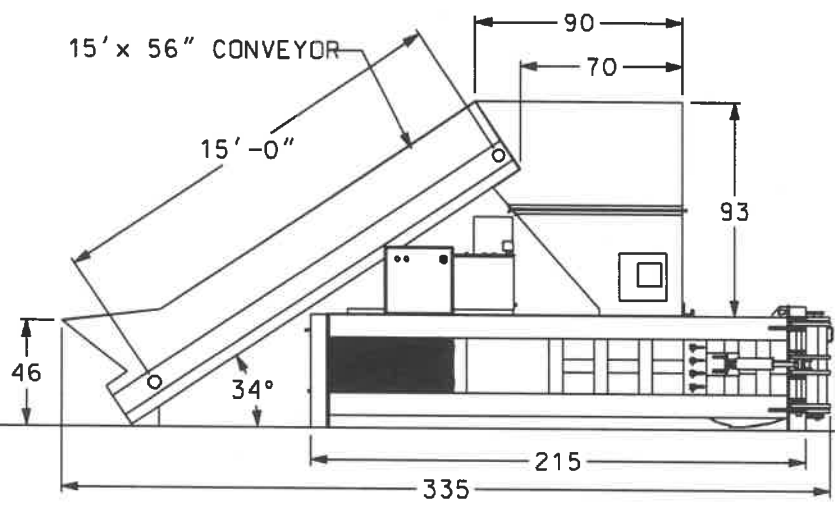
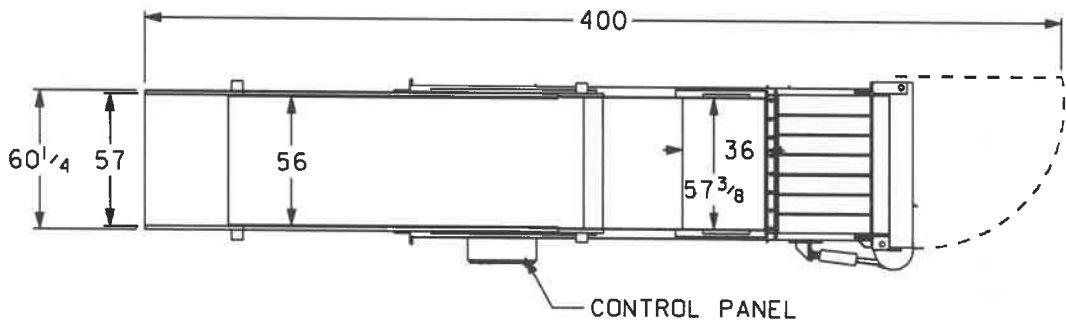

DIMENSIONS SUBJECT TO ENGINEERING CHANGES.

COMPANY NAME: _____
 APPROVED BY: _____
 DATE: _____
 VOLTAGE/PHASE: _____
 RETURN TO: WASTE PROCESSING EQUIPMENT, INC.
 FAX# (256)-638-8979

NOT FOR APPROVAL

UNLESS OTHERWISE SPECIFIED,
DIMENSIONS ARE IN INCHES
TOLERANCES

±1" NOMINAL

APPROVALS	DATE
DRAWN GT	1/30/13
CHECK	
ENGR	

MAX-PAK WASTE PROCESSING EQUIPMENT, INC.
 260 DILBECK ROAD, P.O. BOX 1047
 RAINSVILLE, ALABAMA 35966

TITLE: HCE 60FE-8 SYSTEM
 CONCEPTUAL DRAWING

DWG. NO. HCE60FE-8 SYSTEM-RH

THIS DRAWING IS THE EXCLUSIVE PROPERTY OF WASTE PROCESSING EQUIPMENT, INC. ITS ACCEPTANCE CONSTITUTES AN AGREEMENT THAT IT SHALL BE TREATED AS A STRICTLY CONFIDENTIAL DOCUMENT AND IS NOT TO BE COMMUNICATED, DISCLOSED, OR COPIED UNLESS AUTHORIZED BY WASTE PROCESSING EQUIPMENT, INC.



LIMITED WARRANTY

WASTE PROCESSING EQUIPMENT, INC. warrants all Max-Pak equipment to be free from defects in material and workmanship, under normal use and service as indicated by the owner's manual and manufacturer's specification sheets.

All warranty periods begin on the date of manufacture.

All Standard Vertical MP60HD, Cardboard Balers carry a limited warranty of **two-years** on parts, **one-year** on labor, and **two-years** on the structure. At the end of the first year, labor and shipping costs become the responsibility of the customer. All other Vertical Balers carry a warranty of **one-year** parts and labor.

The warranty period is with the following exceptions/limitations:

- Any single-phase motor will be limited to a 90-day warranty.
- Any Max-Pak Baler used outside the Continental United States will have a warranty of one-year parts only.

All Horizontal Balers carry a limited warranty of **one-year** parts and labor.

All Compactors carry a limited warranty of **one-year** parts and labor.

This warranty shall be limited to the factory authorized repair or replacement of defective parts as stated above. Repair or replacement shall be at the discretion of the manufacturer. The purchaser hereby expressly waives all other damage and claims, statutory or otherwise.

This warranty shall not apply:

If the equipment has been operated in excess of factory recommended specifications and hydraulic pressures.

For processing of material not recommended for introduction into baler.

If failure is due to external electrical service, external conditions or operator error.

If failure or damage occurs through lack of or improper maintenance, accident, improper installation, unauthorized modification, acts of nature, or other causes beyond the control of the manufacturer.

To "wear and tear" consistent with normal machine use.

To any and all electrical components on machines where a phase converter of any type is utilized.

To conveyor belting.

This limited warranty does not cover lost time or contract shortfall due to equipment in operation, whatever the problem.

Modifications of any kind made to the equipment without the express written consent of **WASTE PROCESSING EQUIPMENT, INC.** voids the warranty.

The Customer/Dealer must call Max-Pak and get an approved Service Work Order for any service work to be done. No warranty repair will be paid without an approved Service Work Order number on all paper work. If a part has failed during the warranty period, the Customer/Dealer must return the defective part to Max-Pak within 15 days for testing. If Max-Pak determines the part to be in good working condition or we do not receive the defective part within the given period, Max-Pak will invoice the customer for the new replacement part.

Items not covered by warranty:

1. Fuses.
2. Electrical power source to the equipment.
3. Limit Switch Adjustment.
4. Oil leaks where tightening of Fixtures are indicated.
5. 3-phase electrical components in applications where a "phase converter" is utilized.
6. Wear Materials.
7. Damage caused by improper operation.
8. Eject Chains or Retaining Dogs
9. Conveyor Belts