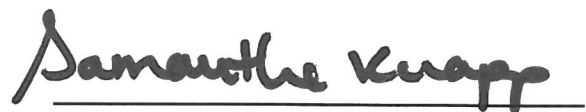

NOTICE

Please note that this bid from GATESAIR INC for EBA20*24 was received at the Purchasing Division office prior to the established bid-opening date and time on April 21, 2020 as noted on the coversheet of the electronic bid, but did not load properly at the public bid opening. This bid has since been loaded and is now posted.

A handwritten signature in black ink that reads "Samantha Knapp". The signature is written in a cursive style and is positioned above a horizontal line.

Samantha Knapp
Acting Assistant Purchasing Director

Header 2

List view

General Information

Contact

Default Values

Discount

Document Information

Procurement Folder: 707905

SO Doc Code: CRFQ

Procurement Type: Central Purchase Order

SO Dept: 0439

Vendor ID: VC0000004453 

SO Doc ID: EBA2000000024

Legal Name: GATESAIR INC

Published Date: 4/15/20

Alias/DBA:

Close Date: 4/21/20

Total Bid: \$413,591.90

Close Time: 13:30

Response Date: 04/17/2020 

Status: Closed

Response Time: 13:37

Solicitation Description: ADDENDUM 1 9600 WATT AIR
COOLED VHF DIGITAL TV 

Total of Header Attachments: 2

Total of All Attachments: 2



Purchasing Division
 2019 Washington Street East
 Post Office Box 50130
 Charleston, WV 25305-0130

**State of West Virginia
 Solicitation Response**

Proc Folder : 707905

Solicitation Description : ADDENDUM 1 9600 WATT AIR COOLED VHF DIGITAL TV TRANSMITTER

Proc Type : Central Purchase Order

Date issued	Solicitation Closes	Solicitation Response	Version
	2020-04-21 13:30:00	SR 0439 ESR04142000000005942	1

VENDOR
VC0000004453 GATESAIR INC

Solicitation Number: CRFQ 0439 EBA2000000024

Total Bid : \$413,591.90 **Response Date:** 2020-04-17 **Response Time:** 13:37:15

Comments:

FOR INFORMATION CONTACT THE BUYER
 Dusty J Smith
 (304) 558-2063
 dusty.j.smith@wv.gov

Signature on File	FEIN #	DATE
--------------------------	---------------	-------------

All offers subject to all terms and conditions contained in this solicitation

Line	Comm Ln Desc	Qty	Unit Issue	Unit Price	Ln Total Or Contract Amount
1	9600 WATT TRANSMITTER	2.00000	EA	\$193,754.950000	\$387,509.90

Comm Code	Manufacturer	Specification	Model #
52161523			

Extended Description : 9600 WATT TRANSMITTER

Line	Comm Ln Desc	Qty	Unit Issue	Unit Price	Ln Total Or Contract Amount
2	Installation of Transmitter	2.00000	EA	\$13,041.000000	\$26,082.00

Comm Code	Manufacturer	Specification	Model #
52161523			

Extended Description : Radio frequency transmitters or receivers

Exhibit A, Pricing Page

Item#	Description	Manufacturer	Part#	Quan.	Cost	Total
1	9600-Watt Transmitter	GatesAir	VAXTE-16R37	2	\$ 193,754.95	\$ 387,509.90
2	Installation / Commisioning	GatesAir	VAXTE-INSTALL	2	\$ 13,041.00	\$ 26,082.00
Total Bid Cost						\$ 413,591.90

**Per section 4.2.3 Vendor must also provide documentation for the equipment quoted sufficient for the Agency to determine whether the quoted equipment meets specifications.
Vendor should provide this documentation with their initial bid.**

 Rich J. Lohmueller, Proposal Mgr.
 Authorized Signature

 04/16/2020
 Date



Proposal

State of West Virginia
Purchasing Division
2019 Washington St. E.
Charleston, WV 25305

**(2) 9600 Watt Air Cooled VHF
Digital TV Transmitters
RFQ #CRFQ 0439 EBA2000000024**

Presented to:

Dusty J. Smith, Buyer

By:

Brian Szewczyk, Regional Sales Manager



5300 Kings Island Dr
Mason, OH USA 45040
1 800.622.0022
gatesair.com

April 21, 2020

State of West Virginia
Purchasing Division
2019 Washington Street East
Charleston, WV 25305

Dear Mrs. Dusty Smith:

On behalf of GatesAir Inc., we are pleased to submit the following response to your RFQ #CRFQ 0439 EBA2000000024 "(2) 9600Watt Air Cooled VHF Digital Transmitters".

We are proposing our Maxiva™ VAXTE Solid-State Air-Cooled UHF transmitters. This transmitter includes the GatesAir PowerSmart® technology architecture providing high efficiency, allowing an increase in power density, lower operating costs, and reduced cost of ownership over the life of the transmitters. All GatesAir products are manufactured and assembled in Quincy, IL USA. I would encourage you to examine and calculate, as part of your review, what the other bidders' transmitter-related costs are associated with the transition to ATSC 3.0 in the near future. I am pleased to let you know that we have included, in our proposal, everything necessary for our transmitter to broadcast in ATSC 3.0 at the same power level as ATSC 1.0. With GatesAir, you will have no additional costs for hardware, software, or services in the future.

Should you require additional information or have any questions, please do not hesitate to contact Brian Szewczyk, Regional Sales Manager at 518-461-9858, or myself at 513-459-3482.

Thank you for your consideration. We look forward to hearing from you soon.

Sincerely,

A handwritten signature in blue ink that reads "Rich Lohmueller".

Rich Lohmueller
Proposal Manager
GatesAir
5300 Kings Island Drive
Mason, OH 45040
Ph.: 513-459-3482
Email: rlohmuell@gatesair.com



Publication Information

Sales Team

Brian Szewczyk

Regional Sales Manager

GatesAir

5300 Kings Island Drive

Mason, OH 45040

Phone: 518-461-9858

Brian.szewczyk@gatesair.com

Systems Architect

Rich Lohmueller

Proposal Manager

GatesAir

5300 Kings Island Drive

Mason, OH 45040

phone 1-513-459-3482

fax 1-513-459-3796

rlohmuel@gatesair.com

©2018 GatesAir, Inc. Proprietary and Confidential.

This document including any attachments or addendums contains material that is confidential or proprietary to GatesAir. It is meant solely for use by the intended recipient. Any review, reliance or distribution of such material by others, or forwarding of such material without express permission, is strictly prohibited.

GatesAir reserves the right, without notice to make such changes in equipment, design, specifications, components, or documentation as progress may warrant to improve the performance of the product.

Trademarks

Maxiva™, Flexiva™, Intraplex®, PowerSmart® are trademarks of GatesAir or its subsidiaries. Microsoft® and Windows® are registered trademarks of Microsoft Corporation. All other trademarks and tradenames are the property of their respective companies.

Contact Information

GatesAir has office locations around the world. For locations and contact information see: <http://www.gatesair.com/contact>

Corporate Headquarters

5300 Kings Island Drive

Cincinnati, OH, USA, 45040

Tel: 1 800-622-0022

Fax: 513-459-3796

Factory Location

3200 Wismann Lane

PO Box 4290

Quincy, IL, USA, 62301

Tel: 217-222-8200



Table of Contents

[Bid Forms](#)

[Detailed Price Quote](#)

[Compliance Statement](#)

[Equipment Brochures & Specifications](#)

[Drawings](#)

[Company Information](#)

GatesAir Standard Terms and Conditions of Sale

<http://www.gatesair.com/documents/StandardTermsandConditions.pdf>



Bid Forms



Purchasing Division
 2019 Washington Street East
 Post Office Box 50130
 Charleston, WV 25305-0130

State of West Virginia
 Request for Quotation
 04 - Audio/Video

Proc Folder: 707905

Doc Description: ADDENDUM 1 9600 WATT AIR COOLED VHF DIGITAL TV TRANSMITTER

Proc Type: Central Purchase Order

Date Issued	Solicitation Closes	Solicitation No	Version
2020-04-15	2020-04-21 13:30:00	CRFQ 0439 EBA2000000024	2

BID RECEIVING LOCATION

BID CLERK
 DEPARTMENT OF ADMINISTRATION
 PURCHASING DIVISION
 2019 WASHINGTON ST E
 CHARLESTON WV 25305
 US

VENDOR

Vendor Name, Address and Telephone Number:

GatesAir, inc.
 5300 Kings Island Dr.
 Mason, OH 45040
 513-459-3400

FOR INFORMATION CONTACT THE BUYER

Dusty J Smith
 (304) 558-2063
 dusty.j.smith@wv.gov

Signature X

FEIN # 46-4956212

DATE 4/16/2020

All offers subject to all terms and conditions contained in this solicitation

ADDITIONAL INFORMATION:

ADDENDUM 1 IS ISSUED FOR THE FOLLOWING REASONS:

1. TO UNLOCK THE FIELDS IN EXHIBIT A PRICING PAGE.

Bid opening and time will remain the same.

INVOICE TO		SHIP TO	
CHIEF FINANCIAL OFFICER EDUCATIONAL BROADCASTING 124 INDUSTRIAL PARK RD		SITE MANAGER EDUCATIONAL BROADCASTING WSWP-TV 124 INDUSTRIAL PARK RD	
BEAVER	WW25813	BEAVER	WW 25813
US		US	

Line	Comm Ln Desc	Qty	Unit Issue	Unit Price	Total Price
1	9600 WATT TRANSMITTER	2.00000	EA	\$193,754.95	\$387,509.90

Comm Code	Manufacturer	Specification	Model #
52161523	GatesAir		VAXTE-16R37

Extended Description :

9600 WATT TRANSMITTER

INVOICE TO		SHIP TO	
CHIEF FINANCIAL OFFICER EDUCATIONAL BROADCASTING 124 INDUSTRIAL PARK RD		SITE MANAGER EDUCATIONAL BROADCASTING WSWP-TV 124 INDUSTRIAL PARK RD	
BEAVER	WW25813	BEAVER	WW 25813
US		US	

Line	Comm Ln Desc	Qty	Unit Issue	Unit Price	Total Price
2	Installation of Transmitter	2.00000	EA	\$13,041.00	\$26,082.00

Comm Code	Manufacturer	Specification	Model #
52161523	GatesAir	Installation & Commissioning Services	

Extended Description :

Radio frequency transmitters or receivers

SCHEDULE OF EVENTS

Line	Event	Event Date
1	TECHNICAL QUESTIONS DUE AT 10AM	2020-04-09

SOLICITATION NUMBER: EBA2000000024

Addendum Number: 1

The purpose of this addendum is to modify the solicitation identified as (“Solicitation”) to reflect the change(s) identified and described below.

Applicable Addendum Category:

- Modify bid opening date and time
- Modify specifications of product or service being sought
- Attachment of vendor questions and responses
- Attachment of pre-bid sign-in sheet
- Correction of error
- Other

Description of Modification to Solicitation:

ADDENDUM 1 IS ISSUED FOR THE FOLLOWING REASONS:

1. TO UNLOCK THE FIELDS IN EXHIBIT A PRICING PAGE.

Bid opening and time will remain the same.

Additional Documentation: Documentation related to this Addendum (if any) has been included herewith as Attachment A and is specifically incorporated herein by reference.

Terms and Conditions:

1. All provisions of the Solicitation and other addenda not modified herein shall remain in full force and effect.
2. Vendor should acknowledge receipt of all addenda issued for this Solicitation by completing an Addendum Acknowledgment, a copy of which is included herewith. Failure to acknowledge addenda may result in bid disqualification. The addendum acknowledgement should be submitted with the bid to expedite document processing.

ATTACHMENT A

ADDENDUM ACKNOWLEDGEMENT FORM
SOLICITATION NO.: EBA2000000024

Instructions: Please acknowledge receipt of all addenda issued with this solicitation by completing this addendum acknowledgment form. Check the box next to each addendum received and sign below. Failure to acknowledge addenda may result in bid disqualification.

Acknowledgment: I hereby acknowledge receipt of the following addenda and have made the necessary revisions to my proposal, plans and/or specification, etc.

Addendum Numbers Received:

(Check the box next to each addendum received)

- | | |
|--|--|
| <input checked="" type="checkbox"/> Addendum No. 1 | <input type="checkbox"/> Addendum No. 6 |
| <input type="checkbox"/> Addendum No. 2 | <input type="checkbox"/> Addendum No. 7 |
| <input type="checkbox"/> Addendum No. 3 | <input type="checkbox"/> Addendum No. 8 |
| <input type="checkbox"/> Addendum No. 4 | <input type="checkbox"/> Addendum No. 9 |
| <input type="checkbox"/> Addendum No. 5 | <input type="checkbox"/> Addendum No. 10 |

I understand that failure to confirm the receipt of addenda may be cause for rejection of this bid. I further understand that any verbal representation made or assumed to be made during any oral discussion held between Vendor's representatives and any state personnel is not binding. Only the information issued in writing and added to the specifications by an official addendum is binding.

GatesAir, Inc.

Company

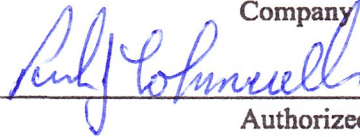

Authorized Signature

4/16/2020

Date

NOTE: This addendum acknowledgment should be submitted with the bid to expedite document processing.

Revised 6/8/2012

Exhibit A, Pricing Page

Item#	Description	Manufacturer	Part#	Quan.	Cost	Total
1	9600-Watt Transmitter	GatesAir	VAXTE-16R37	2	\$ 193,754.95	\$ 387,509.90
2	Installation / Commisioning	GatesAir	VAXTE-INSTALL	2	\$ 13,041.00	\$ 26,082.00
Total Bid Cost					\$	413,591.90

Per section 4.2.3 Vendor must also provide documentation for the equipment quoted sufficient for the Agency to determine whether the quoted equipment meets specifications. Vendor should provide this documentation with their initial bid.

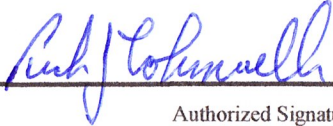

Authorized Signature

4/16/2020

Date

DESIGNATED CONTACT: Vendor appoints the individual identified in this Section as the Contract Administrator and the initial point of contact for matters relating to this Contract.

Brian Szewczyk, Regional Sales Manager
(Name, Title)
Brian Szewczyk, Regional Sales Manager
(Printed Name and Title)
5300 kings Island Dr. Mason, OH 45040
(Address)
518-461-9858
(Phone Number) / (Fax Number)
brian.szewczyk@gatesair.com
(email address)

CERTIFICATION AND SIGNATURE: By signing below, or submitting documentation through wvOASIS, I certify that I have reviewed this Solicitation in its entirety; that I understand the requirements, terms and conditions, and other information contained herein; that this bid, offer or proposal constitutes an offer to the State that cannot be unilaterally withdrawn; that the product or service proposed meets the mandatory requirements contained in the Solicitation for that product or service, unless otherwise stated herein; that the Vendor accepts the terms and conditions contained in the Solicitation, unless otherwise stated herein; that I am submitting this bid, offer or proposal for review and consideration; that I am authorized by the vendor to execute and submit this bid, offer, or proposal, or any documents related thereto on vendor's behalf; that I am authorized to bind the vendor in a contractual relationship; and that to the best of my knowledge, the vendor has properly registered with any State agency that may require registration.

GatesAir, inc.
(Company)

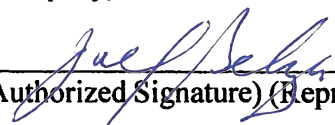
 CFO
(Authorized Signature) (Representative Name, Title)

John Belza, CFO
(Printed Name and Title of Authorized Representative)

4-15-2020
(Date)

office: 513-459-3490 fax: 513-459-3796
(Phone Number) (Fax Number)



Detailed Price Quote



Quote Number: Q-86908
www.gatesair.com

To:

State of West Virginia
2019 Washington St. E
Purchasing Division
Charleston WV, 25305 USA

Attn: Dusty Smith
2063
dusty.j.smith@wv.gov

From:

GatesAir, Inc.
5300 Kings Island Drive, Suite 101
Mason OH, 45040 USA

Brian Szewczyk (304) 558-
Global Sales
brian.szewczyk@gatesair.com

Summary – All Prices are in USD

Summary	Amount
(2) VAXTE-16 VHF TRANSMITTERS	\$383,185.90
(2) Installation/Commissioning Services	\$26,082.00
<hr/>	
Total Equipment/Services	\$409,267.90
Estimated Shipping from Factory	\$4,324.00
Total Quote Price (Optional Items Not Included)	\$413,591.90

Any freight amount shown is estimated and actual amounts will be billed to customer

Is the purchase of this equipment or services exempt from sales tax? YES or NO
If NO - sales tax will be added to your invoices at the rate assigned to the ship to address.

If YES - Sales Tax Exemption Number _____ COPY OF CERTIFICATE MUST BE ATTACHED

Who can we contact regarding sales tax questions on behalf of your company?

Name: _____

Phone Number: _____



Bill To:

State of West Virginia
 2019 Washington St. E
 Purchasing Division
 Charleston WV, 25305 USA

Attn:

Dusty Smith
 558-2063
dusty.j.smith@wv.gov

Ship To:

Educational Broadcasting WSWP-TV
 124 Industrial Dr.

Beaver WV, 25813 USA

Attn:

Dusty Smith (304)
 (304) 558-2063
dusty.j.smith@wv.gov

Quote #: Q-86908

Payment Terms: Net 30 Days

Effective Date: April 21, 2020

Valid Through: June 22, 2020

Send Orders to

orders@gatesair.com

Freight Terms: Destination Prepaid

Estimated Shipment from Factory: 8-10 Weeks

(2) VAXTE-16 VHF TRANSMITTERS

No.	Product #	Qty		
2	VAXTE-16R37	2		

GatesAir Maxiva Series High Efficiency VAXTE-16R37 Air-Cooled, Solid-State, Digital Television Transmitter. Band III, 170-240MHz. 3-1/8in transmitter output connector. Transmitter installed in two 37 RU standard 19in racks.
 12800W DTV Average Power Out (Before Mask filter)
 Single-Phase, 208-240 Volts -15%/+10%, 47-63Hz.
 Optional: Three-Phase, 208-240 or 380-415 Volts, -15%/+10%, 47-63Hz (see Transmitter Technical Manuals for AC installation information)

TRANSMITTER INCLUDES:

- (1) 2 RU Multi-Standard XTE Exciter/Driver with:
 - RTAC(TM) (Real-Time Adaptive Correction)
 - Modulation software upgradeable
 - Easy-to use operator interface via standard Web browser and external PC
 - RTAC(TM) (Real-Time Adaptive Correction)
 - Front panel display and control
 - Built-in compliance monitoring
 - (2) ASI/SMPTE-310 inputs with auto-switching
 - (2) IP Transport inputs with auto-switching
 - 10MHz and 1PPS input for timing reference
 - Integrated GPS receiver (Antenna/cable sold separately)
 - Built in battery UPS
 - For ATSC 1.0 modulation, optional SFN (software key required)
 - (1) VHF Broadband Power Amplifier
 - (1) PA Power Supply

HIGH EFFICIENCY POWER AMPLIFIER BLOCK:

- (16) 3 RU High Efficiency Amplifier Block, including:
 - (2) VHF High efficiency LDMOS Power Amplifier Pallets
 - (1) High efficiency switch mode Power Supply
 - (1) Pre-filter measurement coupler
 - (1) Low pass (Harmonic) Filter
 - (1) Factory Test at Rated Customer Power
 - (2) 37 RU standard Racks (including)
 - Internal Rack AC Distribution
 - Integrated I/O panel with wiring from transmitter to the I/O panel
 - (1) Maxiva VAXTE Series Transmitter Manual



No.	Product #	Qty		
Options (not included, sold separately): - Secondary Exciter (Dual Exciter Option) - Redundant switch mode power supply - Mask Filter - Post Mask Filter Coupler				
3	VAXTE-DD	2		
VAXTE Dual Driver / Exciter option Includes Driver/exciter & Auto switching system (1) 2 RU Multi-Standard XTE Exciter/Driver with: RTAC(TM) (Real-Time Adaptive Correction) - Modulation software upgradeable - Easy-to use operator interface via standard Web browser and external PC - RTAC(TM) (Real-Time Adaptive Correction) - Front panel display and control - Built-in compliance monitoring - (2) ASI/SMPTE-310 inputs with auto-switching - (2) IP Transport inputs with auto-switching - 10MHz and 1PPS input for timing reference - Integrated GPS receiver (Antenna/cable sold separately) - Built in battery UPS - For ATSC 1.0 modulation, optional SFN (software key required) - (1) VHF Broadband LDMOS Power Amplifier - (1) PA Power Supply				
4	VAXTE-SW-AT	4		
VAXTE ATSC Modulation Software				
5	VAXTE-SW-AT3	4		
VAXTE ATSC 3.0 Modulation Software				
6	9929139094	2		
INSTALL MATERIAL KIT, MAXIVA TRANSMITTER. INCLUDES UNISTRUT 10 FT LENGTH, GND STRAP, INTERLOCK WIRE, HARDWARE. 1.0 EA 0034010082 CU, STRAP 0.020 X 2" X 50 75.0 FT 2530059000 CABLE, STP 2C 22AWG GRAY 100 EA 3560089000 CABLE TIE, 5.6 LG, NYLON 50 EA 3560218000 CABLE TIE, 0.190W X 11.5L 50 EA 3581131000 CHANNEL NUT, W/SPRING 3/8-16 6 EA 3582179000 ROD, THREADED 3/8-16 X 10FT LG 30 EA 3582188000 FLAT PLATE FITTING 50 EA 3582598000 CABLE TIE MOUNT, 4-WAY 4 EA 3583308000 CHANNEL, STRUT 1-5/8 X 1-5/8 10FT 4 EA 3583600000 ANGLE, CORNER, FOUR HOLE 4.0 EA 3591053000 PIPE HANGER, J-TYPE 2.00" INS 4 EA 9928544046 ASSY, 3.5 PIPE HANGER W/INSUL 0.5 FT 2960339000 TUBING, SHRINKABLE 1.5 1 EA 3591050000 PIPE HANGER, J-TYPE 3.50 STEEL 1 EA 9929139089 KIT, HARDWARE, MAXIVA 1 PA CAB				
7	FLVA-8000-6AT	4		
Reflective Standard ATSC Mask Filter, 8000W VHF, Air Cooled, 6 Pole filter, Factory Tunable Band Width 6MHZ, 3-1/8 Unflanged Input & Output				
8	STDLINEKT3-1810FT	2		
RF XMSN LINE 3-1/8 10FT KIT CONTAINS: QTY (1) 10FT PIECE OF 3-1/8 XMSN LINE QTY (2) UNFLANGED TO FLANGED ADAPTERS QTY (4) BULLETS				



No.	Product #	Qty		
QTY (8) COUPLING SLEEVES WITH INNERS QTY (4) 90 DERGEE EQUAL LENGTH UN-FLANGED ELBOW				
9	9710078134	2		
KIT BIII, 3-1/8" POST FILTER COUPLE R & RTAC CABLE KIT				
10	7401278000	2		
PARALLEL SURGE SUPPRESSOR, FOR 3PH WYE OR DELTA. Parallel surge protection device combining spark gap type 1 lighting protection and pluggable MOV type 2 transient protection in a NEMA 4X polycarbonate enclosure for 115V-200V, 120V-208V, 120V-240V, 240V-277V & 380V-415V 3 phase Wye or Delta applications with common neutral & ground or Separate neutral & ground.				
11	WNTY_STD	2		
Standard Product Warranty: Warranty of GatesAir manufactured products valid 15 months from date of shipment. Refer to GatesAir Standard Terms and Condition of sales for warranty details.				
(2) VAXTE-16 VHF TRANSMITTERS		Net Unit Price	Ext. Price	
		\$191,592.95	\$383,185.90	



(2) Installation/Commissioning Services

No.	Product #	Qty	Net Unit Price	Ext. Price
12	INSTALL SITE 1	1	\$13,041.00	\$13,041.00

WSWP VAXTE-16 INST.-COMM. SITE1

GatesAir Standard Terms and Conditions and the GatesAir Standard Statement of Work Apply

Includes labor and expenses for (1) GatesAir Service Representative to perform work at (1) site location for WSWP-TV. There are two sites total for this project. The installation services is expected to be completed during the same trip. If either site is delayed, GatesAir will charge the customer for the additional travel expenses needed to completed both transmitter sites for WSWP-TV.

Includes the installation and interconnection of a GatesAir VAXTE-16 dual cabinet transmitter system that may include associated equipment such a RF mask filter (air or liquid cooled), system test load , RF patch panel, or RF switch if purchased.

Includes installation of RF components utilizing clip coupling components which may include soft soldering of system components as necessary on site. Customer to supply appropriate acetylene and oxygen tanks.

Includes complete system commissioning into a known good test load. The commissioning test will be performed utilizing GatesAir calibrated test equipment and standard commissioning test/documentation to GatesAir standard specifications.

The project will be considered and planned to be a start to finish project without delay from installation to commissioning of system into known good test load.

Any customer delays for the installation and commissioning of the GatesAir Transmitter systems that delay the installation or commissioning of the equipment once the GatesAir Service Representative is onsite will be billed to the customer for the extra time on-site at GatesAir standard rates plus expenses.

Project details and assumptions:

Assumes that all GatesAir supplied equipment has been delivered to site prior to the arrival of the GatesAir Service Representative to the site location.

Assumes that the customer has reviewed the GatesAir supplied product documentation and completed all site work associated to support proper installation of all GatesAir supplied equipment and services that is not being provided by GatesAir. Please see the GatesAir Standard Work for Services document for information.

Assumes there will be site access a minimum of (6) days a week and (10) hours per day if required.

Assumes there is adequate space within the facilities to support the installation of all supplied equipment without the removal of any existing equipment.

Assumes there is adequate and proper space within and outside to the building to support cooling system depending on the type of GatesAir transmitter system being installed.

Assumes appropriate electrical and HVAC work to support new equipment has been completed prior to the arrival of the GatesAir Representative.

Assumes the customer hired electrician shall be on site the day of or day after the arrival of the GatesAir service representative to site to discuss equipment layout and final AC connection to each. Assumes all electrical work can be completed without delaying installation and commissioning of equipment. Any delays will be billed to the customer for the extra time onsite.

Assumes the WSWP-TV staff shall be available to support the GatesAir Service Representative with the appropriate site access and other needs as they arise. The work schedule shall be (6) days a week and a maximum of(10) hours per day unless other arrangements are negotiated prior to project start dates depending on the scope of work for the project.

Assumes the customer's antenna connection is within 12ft of location of RF mask filter. Any extra RF line run installation will add extra time to the installation of the equipment and will be billed to the customer for the extra time onsite performing the work.



No.	Product #	Qty	Net Unit Price	Ext. Price
	<p>Does not include repair of any existing transmitters or any other customer equipment that will be reused in the final configuration. Repairs if required and agreed upon will be charged at the standard GatesAir daily rates plus expenses.</p> <p>Does not include any disposal of any equipment that may have been removed during installation process. The customer shall be responsible for proper storage or disposal. Does not include the deinstallation and removal of the existing transmitters currently on site.</p> <p>Does not include Installation or Commissioning Services of any GatesAir supplied equipment as related to towers, antennas, or transmission line from tower to building. Does not include any work beyond commissioning and operational testing of any GatesAir supplied remote control equipment at site. The customer is responsible for the configuration and connection to any link to studio that may exist.</p> <p>Please refer to GatesAir Standard Terms and Conditions of installation and the GatesAir Standard Statement of Work Apply for other details.</p> <p>Does not include any taxes, duties or VAT as related to services performed on -site.</p>			
13	INSTALL SITE 2	1	\$13,041.00	\$13,041.00
	<p>WSWP VAXTE-16 INST. COMM. SITE2</p> <p>GatesAir Standard Terms and Conditions and the GatesAir Standard Statement of Work Apply</p> <p>Includes labor and expenses for (1) GatesAir Service Representative to perform work at (1) site location for WSWP-TV. There are two sites total for this project. The installation services is expected to be completed during the same trip. If either site is delayed, GatesAir will charge the customer for the additional travel expenses needed to completed both transmitter sites for WSWP-TV.</p> <p>Includes the installation and interconnection of a GatesAir VAXTE-16 dual cabinet transmitter system that may include associated equipment such a RF mask filter (air or liquid cooled), system test load , RF patch panel, or RF switch if purchased.</p> <p>Includes installation of RF components utilizing clip coupling components which may include soft soldering of system components as necessary on site. Customer to supply appropriate acetylene and oxygen tanks.</p> <p>Includes complete system commissioning into a known good test load. The commissioning test will be performed utilizing GatesAir calibrated test equipment and standard commissioning test/documentation to GatesAir standard specifications.</p> <p>The project will be considered and planned to be a start to finish project without delay from installation to commissioning of system into known good test load.</p> <p>Any customer delays for the installation and commissioning of the GatesAir Transmitter systems that delay the installation or commissioning of the equipment once the GatesAir Service Representative is onsite will be billed to the customer for the extra time on-site at GatesAir standard rates plus expenses.</p> <p>Project details and assumptions:</p> <p>Assumes that all GatesAir supplied equipment has been delivered to site prior to the arrival of the GatesAir Service Representative to the site location.</p> <p>Assumes that the customer has reviewed the GatesAir supplied product documentation and completed all site work associated to support proper installation of all GatesAir supplied equipment and services that is not being provided by GatesAir. Please see the GatesAir Standard Work for Services document for information.</p> <p>Assumes there will be site access a minimum of (6) days a week and (10) hours per day if required.</p> <p>Assumes there is adequate space within the facilities to support the installation of all supplied equipment without the removal of any existing equipment.</p> <p>Assumes there is adequate and proper space within and outside to the building to support cooling system depending on the type of GatesAir transmitter system being installed.</p> <p>Assumes appropriate electrical and HVAC work to support new equipment has been completed prior to the arrival of the GatesAir Representative.</p> <p>Assumes the customer hired electrician shall be on site the day of or day after the arrival of the GatesAir service representative to site to discuss equipment layout and final AC connection to each. Assumes all electrical work can be completed without delaying installation and commissioning of equipment. Any delays will be billed to the customer for the extra time onsite.</p> <p>Assumes the WSWP-TV staff shall be available to support the GatesAir Service Representative with the appropriate site access and other needs as they arise. The work schedule shall be (6) days a week and a maximum of(10) hours per day unless other arrangements are negotiated prior to project start dates depending on the scope of work for the project.</p> <p>Assumes the customer's antenna connection is within 12ft of location of RF mask filter. Any extra RF line run installation will add extra time to the installation of the equipment and will be billed to the customer for the extra time onsite performing the work.</p> <p>Does not include repair of any existing transmitters or any other customer equipment that will be reused in the final configuration. Repairs if required and agreed upon will be charged at the standard GatesAir daily rates plus expenses.</p> <p>Does not include any disposal of any equipment that may have been removed during installation process. The customer shall be responsible for proper storage or disposal. Does not include the deinstallation and removal of the existing transmitters currently on site.</p> <p>Does not include Installation or Commissioning Services of any GatesAir supplied equipment as related to towers, antennas, or transmission line from tower to building. Does not include any work beyond commissioning and operational testing of any GatesAir supplied remote control equipment at site. The customer is responsible for the configuration and connection to any link to studio that may exist.</p> <p>Please refer to GatesAir Standard Terms and Conditions of installation and the GatesAir Standard Statement of Work Apply for other details.</p> <p>Does not include any taxes, duties or VAT as related to services performed on -site.</p>			
(2) Installation/Commissioning Services TOTAL:				\$26,082.00



Quote Number: Q-86908

www.gatesair.com

TOTAL: \$409,267.90

This Quote, and any Order resulting from this Quote, is subject to the Standard Terms and Conditions of Sale for GATESAIR which can be located at <http://www.gatesair.com/company/legal-compliance/terms-conditions>, which are incorporated herein by reference. The Standard Terms and Conditions for GATESAIR shall apply to the exclusion of any other terms and conditions except where expressly agreed in writing and signed by GATESAIR. For a hard copy of the terms and conditions, please call U.S. (513) 459-3502 or fax your request to (513) 459-3796, Attn.: Legal Dept., or email your request to GAContracts@gatesair.com.

As a part of its marketing efforts, GatesAir may publish general information about this order including customer name, solutions acquired, application for which the solutions are intended, and deal value. GatesAir will not publicize specific prices or other specific Confidential Information.

I do not authorize GatesAir to publicize this order.

Total Equipment/Services	\$409,267.90
Estimated Shipping from Factory	\$4,324.00
Total Quote Price (Optional Items Not Included)	\$413,591.90

Any freight amount shown is estimated and actual amounts will be billed to customer

GatesAir Approval: _____
Brian Szewczyk , Global Sales

Customer Approval: _____

Title: _____

Date: _____

Purchase Order #: _____

Return signed quote to orders@gatesair.com or brian.szewczyk@gatesair.com



Compliance Statement

REQUEST FOR QUOTATION
EBAr68783 VHF DIGITAL TV TRANSMITTERS

Description	Response	Clarification
SPECIFICATIONS		
1. PURPOSE AND SCOPE: The West Virginia Purchasing Division is soliciting bids on behalf of the West Virginia Educational Broadcasting Authority (EBA) to establish a contract for the one-time purchase of 2 (Two) 9600-Watt Air Cooled VHF Digital Television Transmitters.	Understood	
2. DEFINITIONS: The terms listed below shall have the meanings assigned to them below. Additional definitions can be found in section 2 of the General Terms and Conditions.	Understood	GA has read and understands all listed definitions.
3. GENERAL REQUIREMENTS:		
3.1 Mandatory Contract Item Requirements: Contract Item must meet or exceed the mandatory requirements listed below.	Comply	Our offer is for equipment and services which fully meet or exceed all requirements listed below.
3.1.1 Contract Item# 1, quantity two (2) 9600-Watt Air Cooled VHF Digital Television Transmitter, GatesAir VAXTE series transmitter or equivalent	Comply	GA is offering two (2) 12,800-Watt Air Cooled VHF Digital Television Transmitter, GatesAir Maxiva VAXTE series transmitters. They will be adjusted for 9,600W post-filter average power.
3.1.1.1 Manufacturer Qualifications		
3.1.1.1.1 The manufacturer shall have been a provider of broadcast television transmitters for at least 10 years.	Comply	GatesAir (and formerly Harris Broadcast, Gates radio) has been engaged in manufacture of broadcast transmitters for over 80 years.
3.1.1.1.1.1 All transmission products shall be compliant with all FCC (Federal Communications Commission) specifications for service in the United States.	Comply	Meets all FCC rules and regulations.
3.1.1.1.1.2 Manufacturer shall have produced solid-state air-cooled transmitters with power levels of at least 25,000 watts.	Comply	GatesAir has designed, manufactured and shipped air-cooled solid-state Radio transmitters with power levels up to 2MW. GatesAir's current air-cooled TV products are available with power levels up to 25.6kW VHF High Band.
3.1.1.1.1.3 The manufacturer shall have replacement parts available in the continental United States for a period of 10 years from the date of installation.	Comply	Parts support for a minimum of 10 years after the product has been discontinued. We generally have most parts available far beyond this time frame.
3.1.1.1.1.4 The manufacturer shall warrant the transmitter and all associated components to be free from defect for 15 months from the date of on-air commissioning.	Comply	In addition, extended warranties are available, upon request.

REQUEST FOR QUOTATION
EBAr68783 VHF DIGITAL TV TRANSMITTERS

Description	Response	Clarification
3.1.1.2 General		
3.1.1.2.1 Transmitter and shall operate on 208/230V 3 phase power.	Comply	Operates on 208/230 VAC 3-phase power.
3.1.1.2.2 Step down power (120v, 220V, etc.) for exciters and subassemblies shall be derived from the 208/230V power source.	Comply	Exciters and control system are single phase with power derived from the 3-phase input.
3.1.1.2.3 All power components shall be air cooled.	Comply	100% air-cooled.
3.1.1.2.3.1 Power components shall include combiners and filters.	Comply	These are included.
3.1.1.2.4 Transmitter shall be capable of operation at an output power level of 9600 watts. Power output shall be measured POST mask filter	Comply	The offered product, Maxiva VAXTE-16, is rated for 12.8kW pre-filter and can operate up to 12.16kW post-filter. It will set at the factory at the correct power level to provide 9,600W post-filter average DTV power.
3.1.1.2.5 Transmitter shall be installed and operated using the ATSC 1.0 specification, found here: https://www.atsc.org/standards/atsc-standards/ .	Comply	Meets all requirements of ATSC 1.0.
3.1.1.2.6 Transmitter shall have the ability to upgrade to the ATSC 3.0 specification, found here: https://www.atsc.org/standards/atsc-3-0-standards/ .	Comply	Meets all requirements of ATSC 3.0. Upgrade to ATSC 3.0 consist of software only. No hardware changes required.
3.1.1.2.6.1 No reduction in power shall be accepted when changing modulation from ATSC 1.0 to 3.0	Comply	The transmitter offered will make identical power after conversion to ATSC 3.0.
3.1.1.2.6.2 Additional power amplifiers, power supplies, or interstage devices shall not be permitted for transitioning to ATSC 3.0.	Comply	No additional parts or other modifications to hardware are required.
3.1.1.2.7 Transmitter shall be constructed as a single, inclusive unit.	Comply	This is a 2-rack purpose-built TV transmitter, including all parts required for operation.
3.1.1.2.7.1 Transmitter shall operate between channel 7 (174 MHz) and channel 13 (216 MHz).	Comply	Fully broadband over the entire TV High Band spectrum.
3.1.1.2.7.2 No tuning or adjustment shall be required to change frequency within the range of 174 to 216 MHz	Comply	No tuning or adjustment is required.
3.1.1.2.7.3 Transmitter shall be supplied with dual exciters. Exciters shall be configured for "hot standby" operation with automatic switchover upon failure of one of the exciters.	Comply	Dual Exciter/Drivers are included in our offer.
3.1.1.2.8 All modules and subassemblies shall be built by the same manufacturer (No exciter from manufacturer A, Power	Comply	All modules are sub-assemblies are built by GatesAir.

REQUEST FOR QUOTATION
EBAr68783 VHF DIGITAL TV TRANSMITTERS

Description	Response	Clarification
blocks from manufacturer B, control from manufacturer C, etc.)		
3.1.1.2.8.1 Industry standard sub-assemblies such as RF (Radio Frequency) components and power supplies from other manufacturers are permitted with the stipulation that the Vendor shall maintain an inventory of every component and subassembly for a minimum of 10 years from date of commissioning.	Comply	GatesAir will maintain a stock of said parts for > 10 years.
3.1.1.2.9 Vendor shall provide reverse compatible parts and assemblies - future iterations of software and hardware must not require upgrades to the installed units for compatibility.	Comply	If any substitute part must be supplied due to obsolescence, we will substitute equivalent parts that perform the same function.
3.1.1.2.10 Complete system shall operate with a minimum of 40% efficiency at rated power.	Comply	Measured performance of an identical VAXTE-16 transmitter shows it has 41.25% efficiency. (Full factory final test data report available on request).
3.1.1.2.11 Transmitter shall store operating parameters in non-volatile memory during a power outage to allow return to normal operation upon power restoration.	Comply	Included.
3.1.1.2.12 Transmitter shall have protective measures to prevent damage to assemblies and sub-assemblies. These measures at a minimum shall protect against: 3.1.1.2.12.1 Over temperature 3.1.1.2.12.2 Cooling system failure 3.1.1.2.12.3 Loss of single AC Phase 3.1.1.2.12.4 VSWR	Comply	All protections listed and more are included.
3.1.1.2.12.4.1 During high VSWR conditions transmitter shall decrease operating power to a safe level and restore to full power operation upon cessation of reflective anomalies.	Comply	VSWR foldback is included. This allows reduced power operation if the VSWR starts to rise and exceed a preset threshold.
3.1.1.3 Control and Operation		
3.1.1.3.1 System monitoring and Control shall be on the front panel in plain view.	Comply	Front panel control is included and clearly labelled.
3.1.1.3.2 Monitoring		

REQUEST FOR QUOTATION
EBAr68783 VHF DIGITAL TV TRANSMITTERS

Description	Response	Clarification
<p>3.1.1.3.2.1 The following parameters shall be available for display on the front panel</p> <p>3.1.1.3.2.1.1 Forward average power</p> <p>3.1.1.3.2.1.2 Reflected average power</p> <p>3.1.1.3.2.1.3 VSWR</p> <p>3.1.1.3.2.1.4 Power Amplifier Supply Voltages</p> <p>3.1.1.3.2.1.5 Power Amplifier Supply Currents</p> <p>3.1.1.3.2.1.6 Control System Supply Voltages</p> <p>3.1.1.3.2.1.7 Control System Supply Currents</p> <p>3.1.1.3.2.1.8 AC Supply Voltages</p> <p>3.1.1.3.2.1.9 Power Amplifier Module Aggregate Currents</p> <p>3.1.1.3.2.1.10 Power Amplifier Module Aggregate RF Forward Power</p> <p>3.1.1.3.2.1.11 Power Amplifier Module Aggregate RF Reflected Power</p> <p>3.1.1.3.2.1.12 Power Amplifier Heatsink Temperatures</p>	Comply	<p>Displayed on either the front LCD panel and/or a local/remote Web GUI, via Ethernet:</p> <ul style="list-style-type: none"> • Forward average power – On LCD & local remote Web GUI • Reflected average power – On LCD & local remote Web GUI • VSWR – On local/remote Web GUI • Power Amplifier Supply Voltages – On local/remote Web GUI • Power Amplifier Supply Currents – On local/remote web GUI • Control System Supply Voltages - On local/remote Web GUI • Control System Supply Currents - On local/remote Web GUI • AC Supply Voltages - On local/remote Web GUI • Power Amplifier Module Aggregate Currents - On local/remote Web GUI • Power Amplifier Module Aggregate RF Forward Power - On local/remote Web GUI • Power Amplifier Module Aggregate RF Reflected Power - On local/remote Web GUI • Power Amplifier Heatsink Temperatures - On local/remote Web GUI
<p>3.1.1.3.2.2 Monitoring shall include a Fault Summary Log which shall include:</p> <p>3.1.1.3.2.2.1 Exciter Fault</p> <p>3.1.1.3.2.2.2 VSWR Fault</p> <p>3.1.1.3.2.2.3 Control System Fault</p> <p>3.1.1.3.2.2.4 Power amplifier Module Fault</p> <p>3.1.1.3.2.2.5 Cooling System Fault</p> <p>3.1.1.3.2.2.6 Power amplifier Power Supply Fault</p> <p>3.1.1.3.2.2.7 External Interlock</p> <p>3.1.1.3.2.2.8 AC Phase Loss</p> <p>3.1.1.3.2.2.9 Exciter Fault</p>	Comply	<p>All faults are stored in an “event” log. Up to 1,000 entries are stored. After the event log is full, the oldest events are deleted as new events are logged.</p>
<p>3.1.1.3.2.2.10 Fault events shall be stored in memory for recall and display on the transmitter front panel</p>	Comply	Available.

REQUEST FOR QUOTATION
EBAr68783 VHF DIGITAL TV TRANSMITTERS

Description	Response	Clarification
3.1.1.3.2.3 Transmitter "On" and "Off" shall use dedicated buttons or switches.	Comply	Push-button On/Off controls on front of tx.
3.1.1.3.2.4 Touchscreen control is permitted PROVIDING there are tactile switches available for the following functions: 3.1.1.3.2.4.1 Transmitter On. 3.1.1.3.2.4.2 Transmitter Off. 3.1.1.3.2.4.3 Fault Reset.	Comply	Local control is via tactile navigation buttons and a non-touchscreen display. Separate discrete buttons are provided for Transmitter On/Off and Local/Remote.
3.1.1.3.3 There shall be a main system controller controlling: 3.1.1.3.3.1 Power Cabinet 3.1.1.3.3.2 VSWR foldback 3.1.1.3.3.3 External interlock 3.1.1.3.3.4 Power Raise and Lower functions 3.1.1.3.3.5 Remote control interface	Comply	
3.1.1.3.3.5.1 Transmitter shall have a Web based control and monitoring interface included.	Comply	HTML-5 Web-based remote is included.
3.1.1.3.3.5.2 Web GUI (Graphical User Interface) shall use a standard HTML protocol	Comply	HTML-5 Web-based remote is included.
3.1.1.3.3.5.2.1 Java, Javascript, and similar translation software is specifically forbidden.	Comply	No Java is used.
3.1.1.3.3.5.3 Transmitter shall have the ability for external remote control and monitoring.	Comply	External remote control and monitoring is included.
3.1.1.3.3.5.4 Remote control connections shall be parallel with no additional components or modifications required.	Comply	Parallel (GPIO) is included.
3.1.1.4 Exciter		
3.1.1.4.1 Exciter shall be a purpose-built assembly, modified PC (Personal Computer) chassis-based units will not be acceptable.	Comply	No PC-based system is included in the exciter.
3.1.1.4.2 Exciter shall be a stand-alone unit-with the ability to operate outside of the transmitter main assembly for testing.	Comply	It is a separate self-contained complete unit that can be operated on a test bench.
3.1.1.4.2.1 Exciter shall operate on standard US power (110-230VAC, 50-60Hz	Comply	The exciter operates over this range of AC power and +/- 15% beyond.
3.1.1.4.2.2 Exciter shall utilize a standard IEC power cord for standalone operation.	Comply	A standard IEC power cord is used to operate the exciter.
3.1.1.4.2.3 Exciter shall generate a fully processed, pre-corrected, on-channel ATSC 1.0 RF signal	Comply	Exciter generates a fully processed, pre-corrected, on-channel ATSC 1.0 RF signal.
3.1.1.4.3 Exciter shall accept both	Comply	Both input types are included.

REQUEST FOR QUOTATION
EBAr68783 VHF DIGITAL TV TRANSMITTERS

Description	Response	Clarification
ASI/SMPTE 310 inputs AND 1GBE (1 Gigabit Ethernet) TSoIP inputs.		
3.1.1.4.3.1 Exciter shall have 2 (two) ASI/SMPTE 310 inputs capable of automatically switching for redundant operation.	Comply	Two inputs are included with auto-switching between them.
3.1.1.4.3.1.1 Inputs shall be HD-BNC female with a termination impedance to 75 Ohms.	Comply	The exciter uses HD-BNC female connectors for the ASI inputs.
3.1.1.4.3.2 Exciter shall have 2 (two) 1 GBE TSoIP inputs capable of automatically switching for redundant operation.	Comply	Two 1GBE TSoIP inputs capable of automatically switching for redundant operation are included.
3.1.1.4.3.2.1 Inputs shall be RJ45 female.	Comply	RF-45 inputs.
3.1.1.4.4 The clock reference shall be one (1) high stability temperature-controlled oscillator from which all frequencies shall be generated.	Comply	Included.
3.1.1.4.4.1 Stability of the oscillator shall be 4.2 X 10 ⁻⁸ Hertz per month	Comply	Stability is 4.2 x 10 ⁻⁸ Hz/Month.
3.1.1.4.4.2 An internal GPS (Global Positioning System) receiver shall be included for precision frequency referencing.	Comply	GPS receiver is included.
3.1.1.4.4.3 An external GPS reference input shall be included.	Comply	External 1PPS/10Mz input is included.
3.1.1.4.4.3.1 The reference input shall be BNC female	Comply	It is an HD-BNC connector. We provide an adapter (pigtail) cable to convert to BNC (f).
3.1.1.4.4.3.2 The reference input termination impedance shall be 75 Ohms.	Comply	75 Ohms.
3.1.1.5 Power Amplifiers		
3.1.1.5.1 All power amplifier modules shall be solid state.	Comply	100% Solid State.
3.1.1.5.1.1 All RF power modules shall be air cooled.	Comply	100% air-cooled.
3.1.1.5.1.2 All RF power modules shall be "hot-swappable" under full power transmitter operation.	Comply	Fully hot-swappable PA modules from front of tx.
3.1.1.5.1.3 All Power Amplifier modules shall be broadband from 174 to 216 MHz	Comply	Fully broadband across all of the VHF High Band from Ch7 to 13 (174-216MHz).
3.1.1.5.1.3.1 Tuning or configuration shall not be required for change in frequency of operation.	Comply	No tuning, jumpers or config changes are required.
3.1.1.5.1.3.2 Power output shall be uniform for operation from 174 to 216 MHz	Comply	Power output is maintained across all of this band.
3.1.1.5.1.4 Power Amplifiers both as individual units and combined shall operate with identical average power levels under both	Comply	Power amplifiers operate at identical power levels in both modulations.

REQUEST FOR QUOTATION
EBAr68783 VHF DIGITAL TV TRANSMITTERS

Description	Response	Clarification
ATSC 1.0 and ATSC 3.0 modulation standards.		
3.1.1.6 Power Supplies		
3.1.1.6.1 The number of amplifier power supplies shall be equal to the number of amplifiers	Comply	Each PA module has its own dedicated and separate power supply.
3.1.1.6.1.1 Each power supply shall be independent and be replaceable during full power operation.	Comply	Since each power supply is separate from the PA module, it can be replaced in a few seconds from the front of the transmitter.
3.1.1.6.1.1.1 Power supplies shall be removable and not require transmitter to be turned off to re-install.	Comply	Each power supply can be safely removed and replaced without shutting off the transmitter.
3.1.1.6.1.2 Power supplies shall tolerate +/- 15% input variation while maintaining a constant output voltage.	Comply	Power supplies are regulated for at least +/- 15% voltage variations.
3.1.1.6.1.3 Each power supply shall have internal protection at a minimum for: 3.1.1.6.1.3.1 High Temperature 3.1.1.6.1.3.2 Overvoltage 3.1.1.6.1.3.3 Overcurrent	Comply	Protection as required is included.
3.1.1.6.1.3.3.1 Power Supply overload status shall be available locally and remotely.	Comply	Available locally and remotely.
3.1.1.6.1.3.4 Each Power Supply shall have status indicators providing the following information 3.1.1.6.1.3.4.1 Input voltage OK 3.1.1.6.1.3.4.2 Output voltage OK 3.1.1.6.1.3.4.3 High Temperature 3.1.1.6.1.3.4.4 Voltage and/or Current fault	Comply	These indicators are included in each power supply as LED's and also available on the control/remote control system.
3.1.1.7 RF Dividers and Combiners		
3.1.1.7.1 All RF dividers and Combiners shall be broad band and able to operate at any frequency between channel 7 (174 MHz) and channel 13 (216 MHz).	Comply	Fully broadband.
3.1.1.7.1.1 No tuning or phasing shall be required to change operating frequency.	Comply	No tuning or adjustment across this frequency range.
3.1.1.7.2 All combiners shall be air cooled.	Comply	100% air-cooled.
3.1.1.7.2.1 All combiner reject loads shall be air cooled.	Comply	100% air-cooled.
3.1.1.7.2.1.1 Combiner reject loads shall be of sufficient size to accommodate a worst-case amplifier failure or removal.	Comply	Sized appropriately for worst-case conditions.
3.1.1.7.2.1.2 Vendor shall provide an operational chart indicating transmitter power output during multiple module failures and preferred configuration for best acceptable practice for reduced power operation.	Comply	Please refer to attached chart for power under failure conditions.

REQUEST FOR QUOTATION
EBAr68783 VHF DIGITAL TV TRANSMITTERS

Description	Response	Clarification
3.1.1.8 Mask Filter		
3.1.1.8.1 Vendor shall provide an ATSC (Advanced Television Systems Committee) Mask Filter	Comply	Included in our offer.
3.1.1.8.1.1 Filter shall be air cooled	Comply	100% air-cooled.
3.1.1.8.1.2 Filter shall be rated for continuous full power operation.	Comply	Filter power rating exceeds the transmitter max. power rating.
3.1.1.8.1.3 Filter shall be factory tunable for 6MHz bandwidth.	Comply	Will be tuned for proper 6MHz ATSC bandwidth.
3.1.1.8.2 All RF connections and components shall be rated for continuous full power operation.	Comply	All items are sized to handle full power plus additional headroom.
3.1.2 Contract Item# 2, quantity two (2), Installation and Commissioning		
3.1.2.1 Installation		
3.1.2.1.1 Agency shall have all ancillary equipment resources such as power, power outlets, and transmission lines in place prior to Vendor arriving on site for installation.	Understood	Agency to complete items listed.
3.1.2.1.2 Vendor shall provide installation of all assemblies and sub-assemblies.	Comply	Will be provided.
3.1.2.1.3 Sub-contractors are permitted with the stipulation that responsibility for correct installation and adherence to manufacturer's instructions.	Comply	All sub-contractors (if utilized) will meet GatesAir standards and follow instructions.
3.1.2.1.3.1 Certification of sub-contractors shall be the sole responsibility of the vendor	Comply	Noted.
3.1.2.1.4 Vendor shall be responsible for the entire installation from the AC disconnect panel to the output of the Mask Filter	Comply	Included in our offer.
3.1.2.2 Commissioning		
3.1.2.2.1 Vendor shall ensure that all systems are installed correctly and are operating as designed	Comply	All parts of the system will be tested, checked and commissioned as an operating system.
3.1.2.2.2 Vendor shall certify FCC (Federal Communications Commission) compliance with both ATSC 1.0 and ATSC 3.0 operation.	Comply	Compliant with both standards.
3.1.2.2.3 Vendor shall demonstrate backup system operation by deliberately failing (or a reasonable simulation of sub-system failure) of all redundant systems	Comply	Failure of sub-systems and backup operation (Power Amplifier, power supply, etc.), will be demonstrated.
3.1.2.2.4 Entire system shall operate a minimum of 24 hours error free before commissioning is accepted.	Comply	24 hr test period accepted.
3.1.2.2.4.1 Transmitter shall be operated at full	Comply	Tested and commissioned into the

REQUEST FOR QUOTATION
EBAr68783 VHF DIGITAL TV TRANSMITTERS

Description	Response	Clarification
power into a resistive load during commissioning testing.		test load.
3.1.2.2.4.2 Power failure during commissioning testing will not negate the test and be excepted from the "no error" stipulation IF the transmitter recovers to nominal operation without intervention.	Comply	Accepted. Transmitter has ability to re-power normal operation automatically after a power outage.
4. CONTRACT AWARD:		
4.1 Contract Award: The Contract is intended to provide Agencies with a purchase price for the Contract Items. The Contract shall be awarded to the Vendor that provides the Contract Items meeting the required specifications for the lowest overall total cost as shown on the Pricing Pages.	Understood	GatesAir meets all required specifications.
4.2 Pricing Page: Vendor should complete the Pricing Page (Exhibit A) by filling the table with the appropriate information. Vendor should complete the Pricing Pages in their entirety as failure to do so may result in Vendor's bids being disqualified.	Comply	
4.2.1 Vendor should complete the Pricing Page (Exhibit A) by listing a Unit Cost for each Contract Item, multiplying this unit cost by the given quantity, and listing the result as a Total Item Cost for each Contract Item. Vendor should then enter a sum of all Total Item Costs in the Total Bid Cost field.	Comply	
4.2.2 Shipping costs shall be included in the price of equipment.	Comply	
4.2.3 Vendor must include additional documentation for all equipment and components to sufficiently demonstrate that all equipment and components meet specifications. Vendor should include this documentation with their bid. Will be required prior to award.	Comply	
4.2.4 The total cost of the bid shall be the "Total Bid Cost" as described in section 4.2.1	Comply	
4.2.5 The winning Vendor shall be the vendor submitting the bid with the lowest total costs that meet all specifications.	Comply	
4.2.6 If no vendor submits a bid within the budget limitations of the Agency, the Agency may, at its own discretion, cancel this RFQ and purchase nothing.	Comply	
Vendor should electronically enter the information into the Pricing Pages through wvOASIS, if available, or as an electronic	Comply	

REQUEST FOR QUOTATION
EBAr68783 VHF DIGITAL TV TRANSMITTERS

Description	Response	Clarification
document. In most cases, the Vendor can request an electronic copy of the Pricing Pages for bid purposes by sending an email request to the following address: dusty.j.smith@wv.gov.		
5. PAYMENT:		
5.1 Payment: Vendor shall accept payment in accordance with the payment procedures of the State of West Virginia.	Comply	
6. DELIVERY AND RETURN:		
6.1 Shipment and Delivery: Vendor shall ship the Contract Items immediately after being awarded this Contract and receiving a purchase order or notice to proceed. Vendor shall deliver the Contract Items within 90 calendar days after receiving a purchase order or notice to proceed. Contract Items must be delivered to two separate locations: One shall be delivered to: WV Educational Broadcasting Authority Attn: Tom Belcher, (304) 254-7843, TBelcher2@WVPublic.Org #153 Layland, WV 25976 One shall be delivered to: WV Educational Broadcasting Authority Attn: Dave McClanahan, (304) 733-2211, DMcClanahan@WVPublic.Org 9283 Barker Ridge Church Rd Milton, WV 25541	Comply	
6.1.1 Coordination with the listed contact is required prior to delivery at each location.	Comply	
6.1.2 Use of GPS navigation is strongly discouraged. There is a history of guidance systems directing drivers to an impassable section of road.	Comply	Noted.
6.2 Late Delivery: The Agency placing the order under this Contract must be notified in writing if the delivery of the Contract Items will be delayed for any reason. This notification must include the expected delivery date. Any delay in delivery that could cause harm to an Agency will be grounds for cancellation of the Contract, and/or obtaining the Contract Items from a third party. The Agency may accept or reject the delay at its own discretion and will notify Vendor in writing of its decision. Email shall be sufficient for these written notifications.	Comply	

REQUEST FOR QUOTATION
EBAr68783 VHF DIGITAL TV TRANSMITTERS

Description	Response	Clarification
Any Agency seeking to obtain the Contract Items from a third party under this provision must first obtain approval of the Purchasing Division.	Comply	
6.3 Delivery Payment/Risk of Loss: Vendor shall deliver the Contract Items F.O.B. destination to the Agency's location.	Comply	
6.4 Return of Unacceptable Items: If the Agency deems the Contract Items to be unacceptable, the Contract Items shall be returned to Vendor at Vendor's expense and with no restocking charge. Vendor shall either make arrangements for the return within five (5) days of being notified that items are unacceptable or permit the Agency to arrange for the return and reimburse Agency for delivery expenses. If the original packaging cannot be utilized for the return, Vendor will supply the Agency with appropriate return packaging upon request. All returns of unacceptable items shall be F.O.B. the Agency's location. The returned product shall either be replaced, or the Agency shall receive a full credit or refund for the purchase price, at the Agency's discretion.	Comply	
6.5 Return Due to Agency Error: Items ordered in error by the Agency will be returned for credit within 30 days of receipt, F.O.B. Vendor's location. Vendor shall not charge a restocking fee if returned products are in a resalable condition. Items shall be deemed to be in a resalable condition if they are unused and in the original packaging. Any restocking fee for items not in a resalable condition shall be the lower of the Vendor's customary restocking fee or 5% of the total invoiced value of the returned items.	Comply	
7 VENDOR DEFAULT:		

REQUEST FOR QUOTATION
EBAr68783 VHF DIGITAL TV TRANSMITTERS

Description	Response	Clarification
<p>7.1 The following shall be considered a vendor default under this Contract.</p> <p>7.1.1 Failure to provide Contract Items in accordance with the requirements contained herein.</p> <p>7.1.2 Failure to comply with other specifications and requirements contained herein.</p> <p>7.1.3 Failure to comply with any laws, rules, and ordinances applicable to the Contract Services provided under this Contract.</p> <p>7.1.4 Failure to remedy deficient performance upon request.</p>	<p>Understood</p>	
<p>7.2 The following remedies shall be available to Agency upon default.</p> <p>7.2.1 Immediate cancellation of the Contract.</p> <p>7.2.2 Immediate cancellation of one or more release orders issued under this Contract.</p> <p>7.2.3 Any other remedies available in law or equity.</p>	<p>Understood</p>	



Equipment Brochures & Specifications



Connecting What's Next



PowerSmart[®] Plus 

Maxiva[™] VAXTE with PowerSmart[®] Plus

High-Efficiency VHF Band I & Band III
Air-Cooled TV & DAB Transmitters

Maxiva™ VAXTE with PowerSmart® Plus

We did it again.

GatesAir has once again shattered the expectations of what is possible with air-cooled, solid-state transmitters from a cost versus performance ratio.



High-efficiency Power Amplifiers optimized for all TV modulations and for Band III DAB/DAB+

Modular architecture for ease of installation. Multiple transmitters in a single rack saves valuable floor space.

Power levels up to: 30kW Band I; 25.6kW Band III

Separate, hot-swappable, compact power supply for each PA. Redundancy options available.

Separate, hot-swappable, high-efficiency power amplifiers

Optimized Real-Time Adaptive Correction (RTAC™) provides the best performance all the time

More services usually means higher expenses. Higher operating expenses challenge the bottom line. Maxiva VAXTE transmitters with PowerSmart Plus technology drive down total cost of ownership while allowing broadcasters to get the most out of their spectrum. Optimized designs that increase bandwidth while simplifying maintenance. Superior power density that maximizes TV and DAB coverage while reducing transmitter size and weight. Unparalleled performance that enhances broadcast quality while lowering utility bills. GatesAir has once again shattered the expectations of what is possible with high-power, solid-state transmitters from a cost-versus-performance ratio.

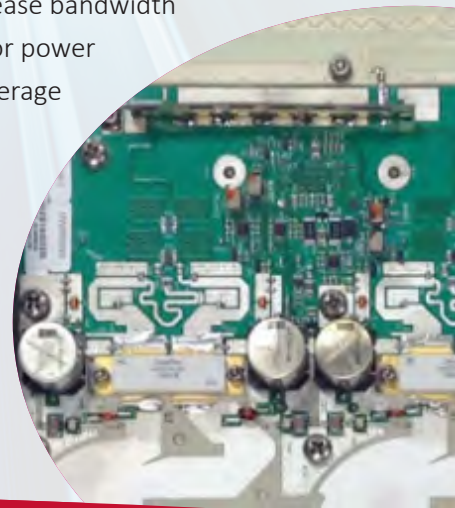

Product Overview

The Maxiva VAXTE is a compact air-cooled TV & DAB transmitter that provides over the air delivery in the VHF spectrum. Built on GatesAir's groundbreaking PowerSmart Plus architecture, the Maxiva VAXTE provides an energy-efficient, broadband solution to reliably deliver rich, high-quality multiformat content to customers at home or on the move.

The core PowerSmart Plus technology of Maxiva VAXTE assures lowest cost of ownership through reduced size, weight and energy use, while providing the highest reliability and performance.

The Maxiva VAXTE utilizes the latest generation 50 volt LDMOS amplifier devices, new compact high-efficiency power supplies and the Maxiva Compact series exciter/driver along with real-time adaptive correction (RTAC) for outstanding signal performance. The Maxiva VAXTE power amplifiers have been optimized to provide the best possible performance and efficiency for all modulations. For example, the VAXTE transmitter is rated for identical average power levels for 8-VSB and OFDM TV modulations, assuring a simple and cost-effective upgrade path for future ATSC 3.0 operation. The modular design further simplifies installation and reduces maintenance costs, dramatically lowering the total cost of ownership over the transmitters life-cycle.

Designed with future broadcasting needs in mind, the VAXTE transmitter is capable of equal power levels for all TV modulations.

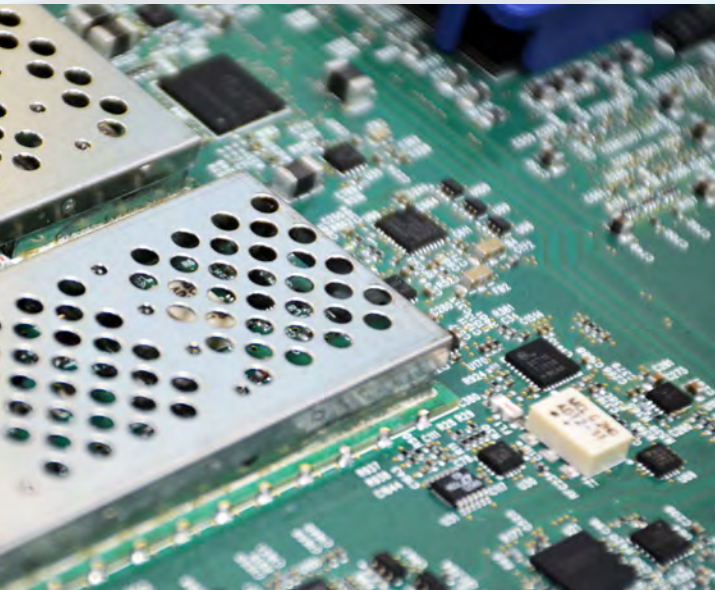

Savings You Can Count On!

The Maxiva VAXTE with PowerSmart Plus is an efficiency-optimized VHF transmitter. This all-new design includes several energy saving features.



New PowerSmart® Plus amplifier technology for VHF provides a market-leading combination of efficiency and broadband operation

Savings in The Details!

- Simple and cost-effective upgrade path from ATSC 1.0 to ATSC 3.0 at the same power level
- Includes TSoIP / Native IP Transport inputs for ATSC 3.0 and DAB EDI interfaces
- Efficiency-optimized – for highest efficiency and lowest cost of ownership
- Variable speed fans to intelligently save energy
- Hot-swappable, compact, high-efficiency DC power supplies
- Hot-swappable, compact, high-efficiency power amplifiers
- Incorporates the XTE-based Maxiva Compact exciter/driver for best-in-class performance
- RoHS compliant / CE compliant
- Support for all worldwide digital modulation standards
- Modular & upgradeable architecture
- All-digital linear and nonlinear pre-correction: Real-Time Adaptive Correction (RTAC)
- Rugged, reliable design and construction
- Broadband high-efficiency PA's support redundancy and N+1 applications
- Lowest energy usage
- Minimum operating cost

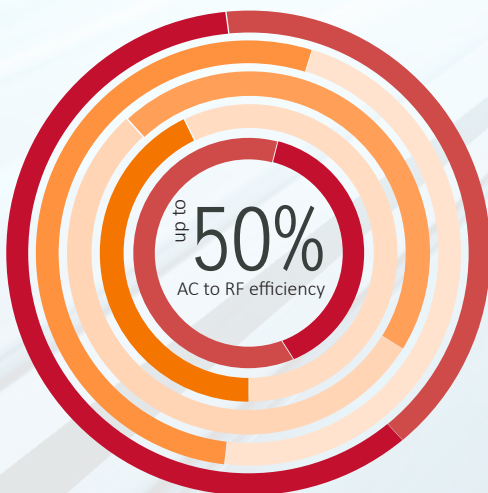

Savings You Can Count On!

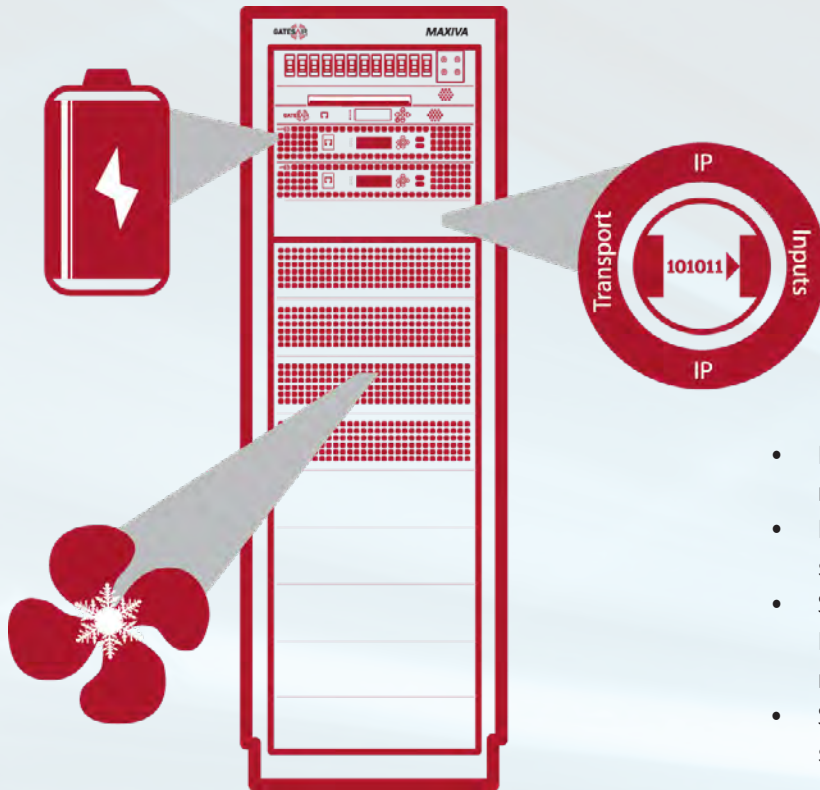

- Intelligent cooling system with variable speed fans to reduce energy consumption.
- Included UPS for the exciter section provides fastest system power-up following an AC power interruption.
- Smaller and lighter PA architecture provides higher RF power during PA or power supply removal and replacement.
- Separate power supplies are easily accessible and hot-swappable from the front of each PA module.

Key Features

Features	Included	Available
Equal power levels for ATSC 1.0 and ATSC 3.0	•	
Fast-acting linear and non-linear Real-Time Adaptive Correction (RTAC) for optimum performance at all times	•	
Web remote with SNMP	•	
Parallel Remote Control	•	
Internal GPS/GLONASS receiver for SFN timing	•	
Exciter internal UPS option	•	
ASI/T2MI over IP / IP transport input (Ready for ATSC 3.0)	•	
EDI and ETI DAB/DAB+ inputs	•	
Dual exiters and switcher		•
Redundant power supplies for each PA module		•
Local touch-screen GUI		•
N+1 systems and multi-transmitters per rack		•
Extended warranties and Service Level Agreements (SLA) to suit any requirement		•



Maxiva VAXTE Drive — The Heart of the Transmitter

The software-defined Maxiva VAXTE Drive takes digital and mobile TV and radio to the next level. Offering the most advanced exciter technology available, the core Maxiva XTE platform used in the VAXTE Drive employs advanced Real Time Adaptive Precorrection techniques, Native dual TSolP inputs and many other updates, providing a truly future-proof design. The ability to store two different modulations allows fast and easy future upgrades, for example from ATSC 1.0 to ATSC 3.0.

Integrated within all Maxiva VAXTE air-cooled transmitters, the Maxiva VAXTE Drive delivers an RF signal with complete technical and regulatory compliance for all solid-state digital transmitters. The Maxiva XTE is the only exciter designed and manufactured in the USA that is 100% ready for ATSC 3.0.

Real-Time Adaptive Correction

GatesAir's exclusive Real-Time Adaptive Correction (RTAC) technology, standard in Maxiva transmitters, keeps your station within compliance while maximizing coverage. Featuring simultaneous linear and nonlinear adaptive pre-correction, RTAC interoperates with the Maxiva Compact Drive exciter to continuously monitor transmitter output and performance while automatically adapting for system nonlinearities — delivering the optimal level of correction for your digital over-the-air signal.



Advanced Global Monitoring and Control

In addition to local control, the Maxiva VAXTE transmitter can be controlled from anywhere in the world with an intuitive, browser-based graphical user interface (GUI) over TCP/IP via a telecom or network connection with password protection. A rear RJ-45 jack is provided for LAN/WAN connection.

Full Simple Network Management Protocol (SNMP) facilities are provided for network management of the entire transmission system using industry-standard MIB.

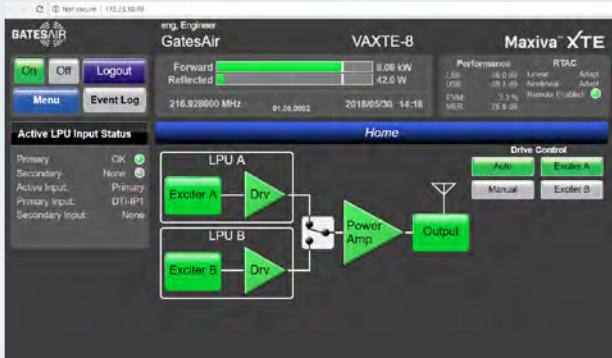

Remote Communication

The following remote interfaces are available:

- HTML5 Graphical User Interface (no Java or Flash required)
- Ethernet network connection RJ-45 (10/100/1000Base-T) with TCP/IP protocol
- Automated remote alarms in the event of a fault, which are sent via SNMP or e-mail with the connection to a network
- Simple, parallel interface to panels and legacy remote control systems

Multi-System Controller

To support greater redundancy, the Multi-System Controller supports a range of backup options, including 1+1, full N+1 and dual-transmitter installations. The Multi-System Controller monitors and controls the transmitter systems and also controls RF switching.

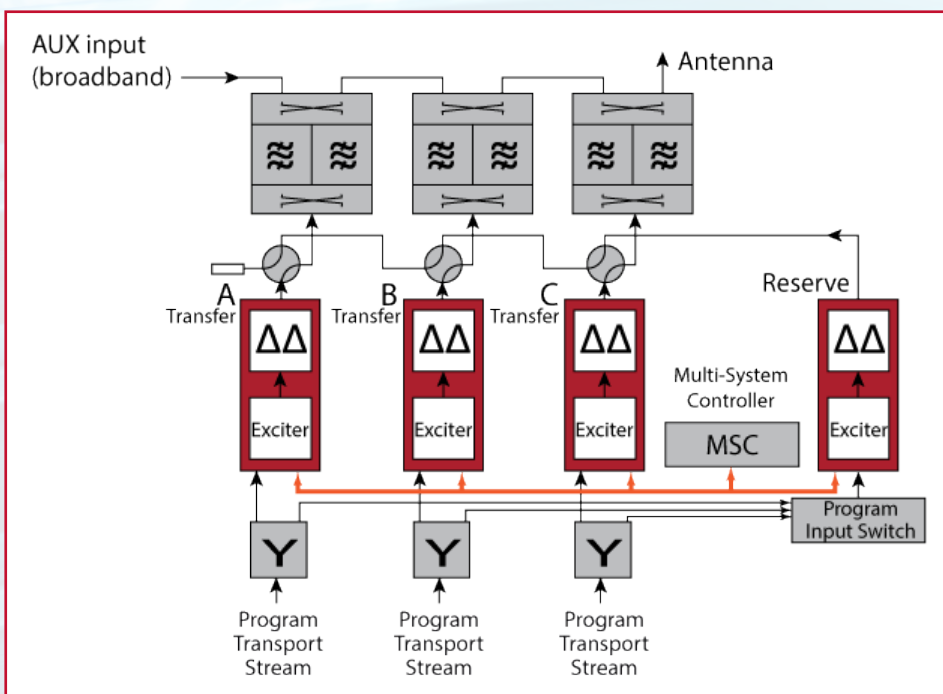

What is Total Cost of Ownership (TCO)?

TCO is the total cost to own and operate the transmitter system over time. This includes the initial equipment cost, installation/commissioning cost, routine and unscheduled maintenance costs, and ongoing repair and operational costs — and don't forget, rising energy costs. In fact, the lifetime operational expense of a transmitter is estimated at greater than five times the initial product cost.

While power to the transmitter is the biggest item, other factors can also adversely affect the system efficiency. These include:

- AC transformers and voltage regulators ahead of transmitter
- Heat load to the room (affects HVAC costs)
- RF system losses
- RF feeder loss to antenna
- Antenna gain and pattern

Maxiva VHF transmitters now incorporate GatesAir PowerSmart Plus technology to help broadcasters save money and reduce carbon footprints. PowerSmart Plus technology delivers superior operational efficiency through fully broadband, single-amplifier designs that simplify installation, improve performance, and streamline ongoing operation — including maintenance. This comes courtesy of a modular design that eliminates tuning, reduces weight, enhances redundancy through separate power supplies, and minimizes overall labor.

PowerSmart Plus technology also lowers monthly bills through sharp power efficiency increases (up to 50 percent), and slashes rack space requirements (exceeding 50 percent) through a dramatic increase in power density. These industry-leading strides in performance and physical size reduction combine to deliver the best possible total cost of ownership over the life of the transmitter — and return money to the pockets of our customers.

Typical Total Cost of Ownership Over 20 Years

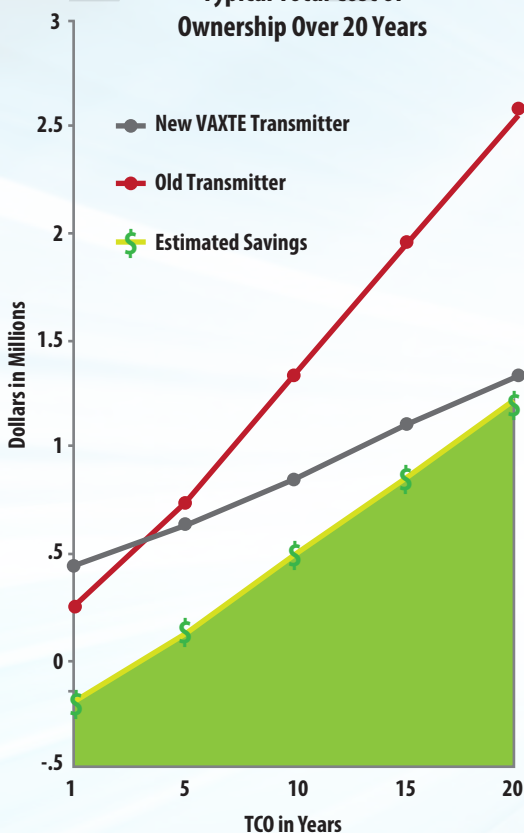

PowerSmart[®] Plus

Broadband Amplification

PowerSmart Plus incorporates groundbreaking broadband amplifier designs into Maxiva VAXTE transmitters. The Maxiva VAXTE power amplifiers have been optimized to provide the best possible performance and efficiency for all modulations. The VAXTE transmitter is rate for identical average power levels for both modulations, assuring a simple and cost-effective upgrade path for future ATSC 3.0 operation. These designs also consolidate spare parts and eliminate tuning and adjustments to further simplify maintenance and ongoing operation.

Compact Design

The reduced size of the VAXTE transmitter will minimize the use of valuable rack space in your transmitter facility. This provides space for other equipment, or multiple transmitters in a single rack, often eliminating the need for additional racks and the associated floor space needed.

Global Monitoring and Control

The Maxiva VAXTE transmitter can be controlled from anywhere in the world with an intuitive, browser-based GUI or SNMP over TCP/IP via a telecom or network connection with password protection.

Reduced Service Costs

Easy access to hot-swappable power amplifier modules and power supplies, makes on-air servicing easy and eliminates costly service interruptions. Light-weight universal PA pallets and modules facilitate overnight/same-day shipping for simple, cost-effective spares management. With lightweight subassemblies, the Maxiva VAXTE eliminates two-person lift requirements for routine maintenance and troubleshooting.



Maxiva VAXTE Block Diagram

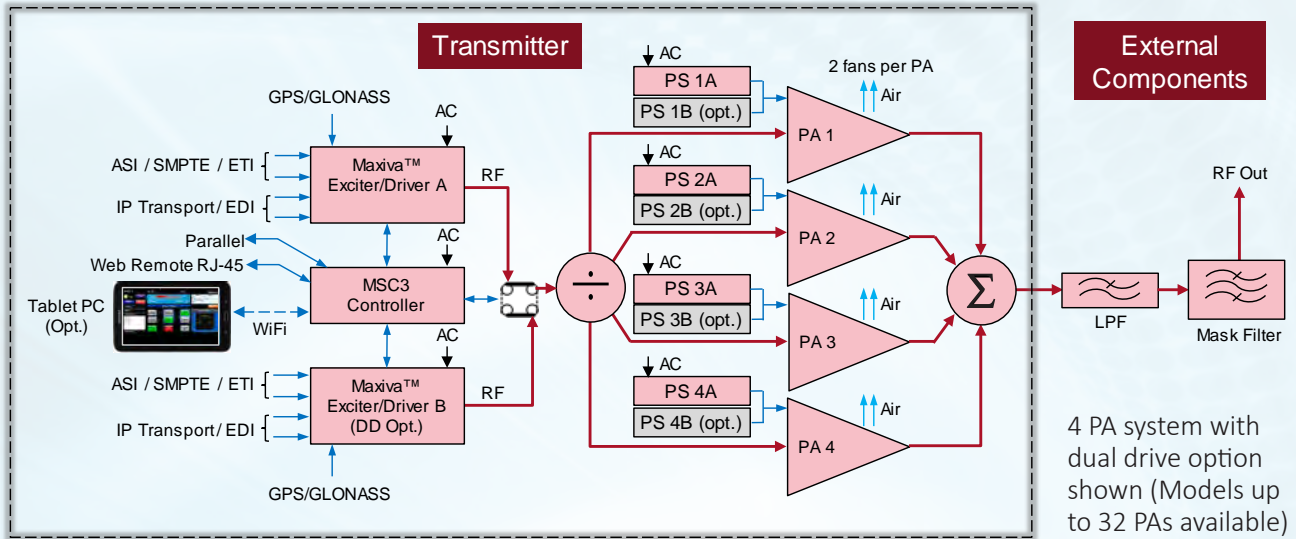

Maxiva VAXTE Models and Power Levels Band III TV

Model	HPA's	Rack Space	# Racks	Avg Power Pre-Filter (W)
VAXTE-10-C	0	2RU	0	15
VAXTE-100-C	0	2RU	0	100
VAXTE-200-C	0	2RU	0	200
VAXTE-1P-C	1 (1 pallet)	4RU	0	400
VAXTE-2P-C	1 (2 pallets)	4RU	0	800
VAXTE-1-1P	1 (1 pallet)	1 Rack (37RU)		400
VAXTE-1	1	1 Rack (37RU)		800
VAXTE-2	2	1 Rack (37RU)		1,600
VAXTE-3	3	1 Rack (37RU)		2,400
VAXTE-4	4	1 Rack (37RU)		3,200
VAXTE-6	6	1 Rack (37RU)		4,800
VAXTE-8	8	1 Rack (37RU)		6,400
VAXTE-12	12	2 Racks (37RU)		9,600
VAXTE-16	16	2 Racks (37RU)		12,800
VAXTE-24	24	3 Racks (37RU)		19,200
VAXTE-32	32	4 Racks (37RU)		25,600

Band I TV

Model	HPA's	Rack Space	# Racks	Avg Power Pre-Filter (W)
VAXTE-10L	0	2RU	0	10
VAXTE-100L	0	2RU	0	100
VAXTE-200L	0	2RU	0	200
VAXTE-1L	1	1 Rack (42RU)		1,250
VAXTE-2L	2	1 Rack (42RU)		2,500
VAXTE-3L	3	1 Rack (42RU)		3,750
VAXTE-4L	4	1 Rack (42RU)		5,000
VAXTE-6L	6	1 Rack (42RU)		7,500
VAXTE-8L	8	1 Rack (42RU)		10,000
VAXTE-12L	12	2 Racks (42RU)		15,000
VAXTE-16L	16	2 Racks (42RU)		20,000
VAXTE-24L	24	3 Racks (42RU)		30,000

DAB / DAB+ / T-DMB

Model	HPA's	Rack Space	# Racks	Power Pre-Filter (W)
VAXTE-10-C	0	2RU	0	15
VAXTE-100-C	0	2RU	0	150
VAXTE-200-C	0	2RU	0	250
VAXTE-1P-C	1 (1 pallet)	4RU	0	500
VAXTE-2P-C	1 (2 pallets)	4RU	0	1,000
VAXTE-1-1P	1 (1 pallet)	1 Rack (37RU)		500
VAXTE-1	1	1 Rack (37RU)		1,000
VAXTE-2	2	1 Rack (37RU)		2,000
VAXTE-3	3	1 Rack (37RU)		3,000
VAXTE-4	4	1 Rack (37RU)		4,000
VAXTE-6	6	1 Rack (37RU)		6,000
VAXTE-8	8	1 Rack (37RU)		8,000

Specifications

Specifications and designs are subject to change without notice.

General	
Frequency Range	VHF Band I and Band III models
Transmission Standards	ATSC 1.0, ATSC 3.0, DVB-T, DVB-T2, ISDB-T, DAB/DAB+/T-DMB
Channel Bandwidth.....	TV: 6, 7 or 8 MHz (system dependent) DAB: 1.536 MHz
Rated Power Output	10W to 25.6kW Band III, 10W to 30kW band I before mask filter
Output Power Reduction Range	0 to -10 dB
RF Load Impedance	50 ohms
VSWR.....	Protected against open or short circuit, all phase angles. Capable of operation into infinite VSWR with user-adjustable fold back threshold. Factory pre-set to 4% of nominal nameplate power (VSWR = 1.5:1)
RF Output Connector.....	Power level dependent. Consult GatesAir drawings for connector sizing

AC Mains	
AC Line Voltage	3 phase: 380 to 415 V, or 208 to 240 V, 50/60 Hz, or single phase 208 to 240 V, 50/60 Hz - specify voltage when ordering
AC Line Variation.....	Regulated for a $\pm 15\%$ input voltage variation, when operated between 208-230 V, or between 380-400V
Power Factor	>0.95

Environmental	
Altitude.....	Up to 8,200 ft (2,500 m) elevation above mean sea level
Ambient Temperature.....	32° to 113° F (0° to 45° C) at sea level (upper limit derated 3.6° F (2° C) per 984 ft (300 m) elevation AMSL)
Humidity.....	95%, non-condensing
Cooling Method	Air-cooled with internal fans, air flow front to rear (external air using optional front air plenum)
Acoustic Noise.....	<65 dBA (measured 1 m in front of cabinet), with external input air plenum/door
Frequency Stability	Without precision frequency control/ GPS: ± 150 Hz/month (2.3 x 10 ⁻⁷ ppm)

External Inputs (at each LPU)	
GPS Input	SMA female, 50 ohms, (+5 V DC @ 100 mA max output for active antenna)
1 PPS Input	HD-BNC female, user selectable 50 ohms or high impedance termination
10 MHz Reference Frequency Input...	HD-BNC female, 50 ohms

Monitoring Outputs	
RF monitor (exciter)	SMA female
1 PPS.....	HD-BNC female
10 Mhz	HD-BNC female

ATSC 1.0 Specification	
Power Output (average)	Up to 30 kW models available, measured before mask filter [See power level table]
Standards	ATSC A-53, 8-VSB DTV standard
Data Input	19.39 Mb/s, configurable as SMPTE-310M or ASI (user selectable)
Impedance	75 ohms, unbalanced
Input Connector.....	2 inputs, HD-BNC female
Signal to Noise (EVM)	>27 dB (EVM <4%), Typical >32 dB (EVM <2.5 %)
Phase Noise.....	<104 dBc/Hz @ 20 kHz offset (ATSC A/64)
Harmonic Radiation & Spurious	Meets mask requirements specified in FCC 5th and 6th report and order
Sideband Performance	Compliant with FCC radiation mask, when measured at the output of GatesAir-supplied output filter

ATSC 3.0 Specification	
Power Output (average)	Up to 30 kW models available, measured before mask filter [see table]
Standards	A/321:2016 System Discovery and Signaling A/322:2017 Physical Layer Protocol A/324: Scheduler / Studio to Transmitter Link
ASI/T2MI Inputs	2 inputs HD-BNC female; 75 ohms according to EN 50083-9. Supports seamless switching between ASI/T2MI inputs for DVB-T2 (for DVB-H: 2 main/2 hierarchical)
ASI/T2MI over IP / IP transport.....	2 inputs, 100/1000BASE-T
Crest Factor	13 dB maximum
Shoulder Level.....	<-37 dB (before mask filter)
END	<0.5 dB
MER.....	>34 dB (typical 36 dB)
Harmonics (before filter)	<-40 dB
Central Carrier Suppression.....	>75 dB
ATSC 3.0 Modes	Supports Multiple PLP's, LDM, Bandwidth Reduction, MISO, PAPR Reduction and other features per ATSC 3.0 Physical Layer Protocol A/322
SFN Timing	Per ATSC 3.0 standard A/324:2018, "Scheduler / Studio to Transmitter Link"

Specifications

(continued)

DVB-T, DVB-T2 & ISDB-T Specification	
Power Output (average)	Power levels available for all applications [see tables for Band I and Band III TV]
Standards	DVB-T/H: standard EN 300 744 DVB-T2, DVB-T2 Lite: standards EN 302755 v1.4.1, TS 102 831 v1.2.1, TS 102 773 v1.3.1 ISDB-Tb: Complies with Brazil ANATEL standard
ASI/T2MI Inputs	2 inputs HD-BNC female; 75 ohms according to EN 50083-9 Supports seamless switching between ASI/T2MI inputs for DVB-T2 (for DVB-H: 1 main / 1 hierarchical)
IP Transport Inputs.....	2 inputs, 10/100/1000Base-T, RJ-45
Crest Factor	13 dB maximum
Shoulder Level.....	<-37 dB (before mask filter)
END	<0.5 dB
MER.....	≥34 dB (typically >36 dB)
Harmonics (before filter)	<-60dB, or FCC 5th & 6th report and order, measured after Low Pass Filter
Central Carrier Suppression.....	>75 dB
Spurious Emissions	<-60dB, measured after Low Pass and Mask Filters
DVB-T2 Modes	Supports multiple PLP's, MISO, extended bandwidth mode, PAPR reduction, DVB-T2 Lite
SFN Delay	Static and Dynamic, 0 to 1 second per ETSI TS 101 191 V1.4.1 (2004-06)

DAB / DAB+ / T-DMB Specification	
Power Output (average)	15W to 8kW
Standards	DAB / DAB+ per ETSI EN 300 401 V2.1.1 (2017-01), ETSI EN 300 797 V1.3.1, ETSI TR 101 496-1 V1.1.1
Output Power Stability.....	≤ ±0.25 dB
Signal Inputs.....	2x ETI: (NI, G703) or 2x ETI (NA, G704), with automatic seamless input signal switchover 2 x EDI: 100/1000 Base-T RJ-45, per ETSI TS 102 693 V1.1.2 (2009-11) UDP/DCP, or TCP/DCP protocol. Supports Unicast and Multicast (IGMPv2 and IGMPv3)
Monitoring Output	Confidence monitor for ETI, 1 x 75 ohm HD-BNC
Crest Factor	13 dB maximum
Shoulder Level.....	<-37 dB
MER.....	Range is >25dB to >32dB, dependent on efficiency optimization settings
Harmonics and Spurious.....	Meets ETSI EN 302077-2 V1.1.1, after band-pass filter

Remote Control	
Parallel Remote	25 conductor D-sub for single drive basic rack, 12 conductor terminal block (mini Wago) on deluxe rack
Ethernet/SNMP/Web	10/100/1000Base-T, RJ-45

Compliance	RoHS 2011/65/EU Directive 2014/53/EU Safety: EN 60215 EMC: EN 301-489-1 FCC Part 73 Manufacturing: ISO 9001: 2008
------------------	--





Maxiva™ XTE

Software-Defined Exciter for All TV and DAB/DAB+ Radio Standards



The new GatesAir Maxiva™ XTE exciter provides broadcasters with a powerful, software-defined platform, enabling the ultimate in performance, stability and durability.

Featuring unparalleled signal processing power, a smaller footprint and advanced Transport Stream over IP (TSolP) input capabilities, Maxiva XTE builds upon a strong legacy of groundbreaking technological advances, pioneered by several decades of GatesAir innovations. Dramatically increased processing power together with new, advanced Real-Time Adaptive Correction techniques, provides optimum signal performance over a wide variety of modulations and RF amplifier topologies.

The Maxiva XTE supports a full range of digital broadcast standards, including ATSC, DVB-T/H, DVB-T2, ISDB-T, DTMB, DAB/DAB+/DMB. It is upgradeable to future new modulations, including ATSC 3.0, as they become available.

Maxiva XTE Features

- Advanced Real-Time Adaptive Correction (RTAC)
- Optimized correction for all amplifier types
- Frequency Agile – Band I, III, IV and V
- Supports all widely used TV standards and DAB/DAB+ radio
- Upgradeable to emerging digital standards
- Available Internal GNSS (GPS/GLONASS) receiver for precision frequency control and/or timing required for SFN
- Available Internal UPS
- Compact 1RU design
- Dual redundant TSolP inputs with seamless auto-switching
- Dual redundant transport stream inputs with seamless auto-switching for ASI/T2MI
- Integrated ISDB-Tb Remux
- Seamless integration with GatesAir transmitters
- Intuitive Web GUI interface with HTML
- Advanced monitoring and diagnostics support

Product Details

Cost-Efficient, Advanced Pre-correction

The Maxiva XTE incorporates advanced pre-correction techniques that assure optimum signal performance, linearity and efficiency for all types of power amplifiers. The GatesAir RTAC™ system operates continuously, adapting to varying environmental and other conditions that could otherwise impact on-air performance.

Upgradeable & Flexible Design

The software defined XTE provides broadcasters the latest technology and digital correction for today's transmitter amplifier technologies. For example, SMPTE 2022 standardized IP technology for transport stream input and precision timing per IEEE 1588 lower overall infrastructure costs.

Maxiva XTE Front and Rear Panels

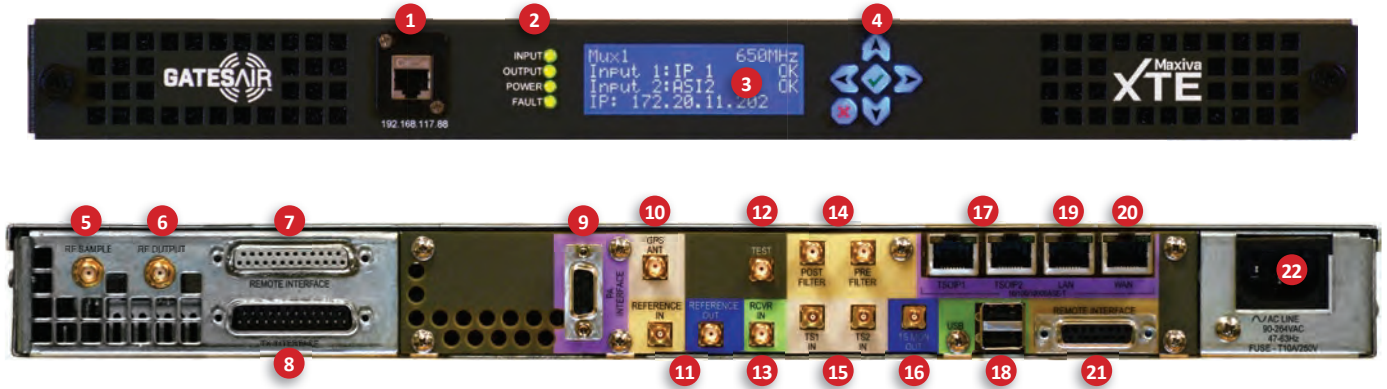

- | | |
|--|--|
| 1 Front Ethernet for Control/Set-up | 12 Test |
| 2 Status LEDs | 13 Receiver Input |
| 3 Local GUI | 14 RTAC Inputs (Pre & Post Filter) |
| 4 Pushbutton GUI Navigation | 15 Transport Stream Input 1 / Input 2 |
| 5 RF Sample | 16 TS Monitor Output |
| 6 RF Output | 17 TSoIP Input 1 / Input 2 |
| 7 Remote Interface | 18 USB Mass Storage |
| 8 Transmitter Interface | 19 LAN (10/100/1000 BaseT) |
| 9 PA Interface | 20 WAN (10/100/1000 BaseT) |
| 10 GNSS Antenna Input (GPS/GLONASS) | 21 PA Interface |
| 11 10MHz/1PPS Reference In/Out (User Selectable) | 22 AC Power Input (90 to 264VAC, 47 to 63Hz) |

Maxiva XTE Block Diagram

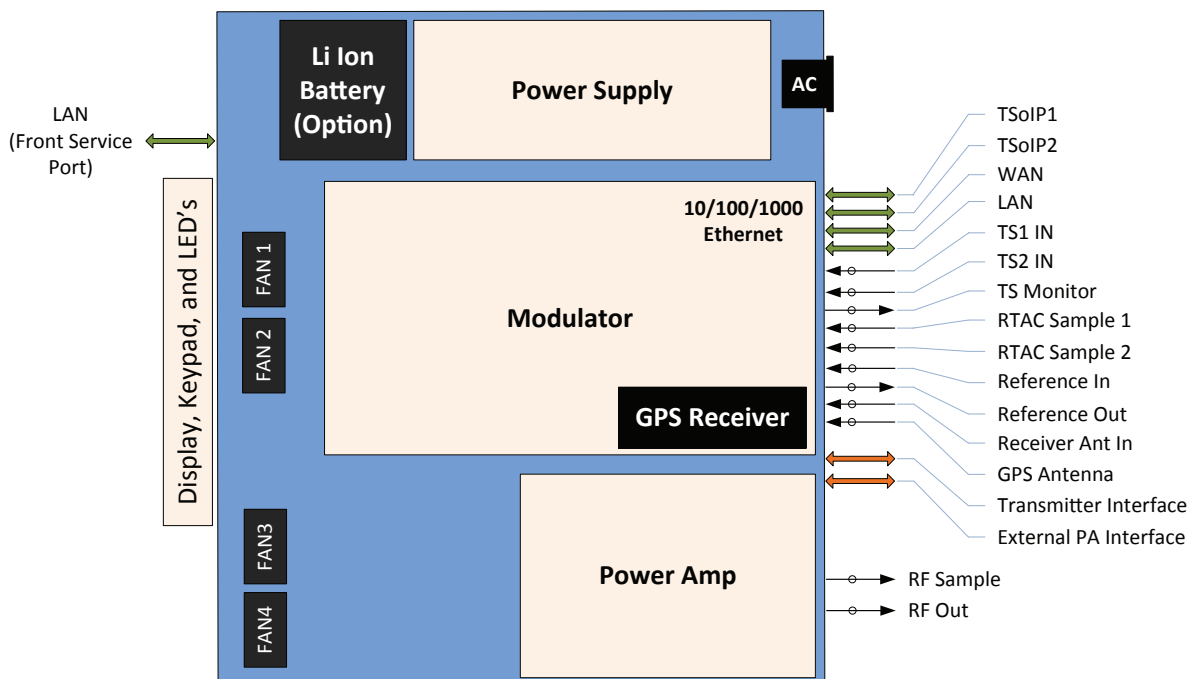

Maxiva XTE Specifications

Specifications and designs are subject to change without notice

General	
Main RF Output Connector	1 Rear SMA, 50 ohms, Max. +20dBm (100mW)
Aux. RF Output Connector	1 Rear SMA, 50 ohms, Max. +20dBm (100mW)
RF Input Samples for Adaptive Correction	2 Rear SMA, 50 ohms dynamic range: -20 to +10 dBm
Frequency Range	VHF and UHF, Bands I/III/IV/V
Transport Stream Inputs	2 Rear HD-BNC, 75 ohms, configurable as DVBASI/T2-MI/SMPTE 310M/ETI
Transport Steam over IP Inputs	2 Rear RJ-45 10/100/1000 BaseT
10 MHz Reference Input	1 Rear HD-BNC 0 to +18dBm
1 PPS Reference Input	1 Rear HD-BNC TTL level
10 MHz Reference Output	1 Rear HD-BNC
1 PPS Reference Output	1 Rear HD-BNC
Ethernet	1 Front RJ-45, DHCP enabled, customer access
LAN	1 Rear RJ-45 10/100/1000 BaseT
WAN	1 Rear RJ-45 10/100/1000 BaseT
USB Mass Storage	2 Rear (USB 2.0 High Speed)
GNSS Antenna Input (GPS/GLONASS)	1 Rear SMA 50 Ohms
AC Power Input	90 to 264 VAC, 47 to 63 Hz, autoranging
Environmental	Temperature range: 0° to 50°C (32° to 122°F) up to 4,500 m (14,764 ft) AMSL. Derate 2° C (3.6°F) per 984 t (300 m) of elevation Humidity: Up to 95% relative humidity, noncondensing
Physical	19 in. EIA rack standard, 1RU high, 19 in. depth
ATSC Specifications	
Standards	ATSC A/53, A/153, A/110:2011
Maximum Power Output	+20dBm (100mW) Average
Regulation of Output Power	<0.25dB
Pilot Frequency Stability	Without precision frequency control/GPS: ±150 Hz/month (2.3 x 10 ⁻⁷ ppm)
Frequency Setting / Offsets ¹	Any frequency within band, with 1Hz setting increments
Frequency Response variation	0.2dB, typical
Group Delay	2nS, typical
Phase Noise	<104dBc/Hz@ 20kHz offset (ATSC A/64)
Spurious Output ²	In Band: -68dB (-45dB as measured in 30kHz RBW) Adjacent channels -68dB (-45dB as measured in 30kHz RBW) All others -40dB
Signal to Noise Ratio (SNR)	35dB, typical

Note:

¹ High-stability external 10MHz/1PPS reference, or optional built-in GNSS receiver required for SFN

² Signals referenced to center channel, at rated output power, measured with 30kHz RBW

ATSC 3.0, DVB-T, DVB-T2, ISDB-Tb, DAB/DAB+/DMBT Specifications	
Maximum Power Output	+20dBm (100mW) Average
Regulation of Output Power	<0.25dB
Frequency Stability	Without precision frequency control/GPS: ± 150 Hz/month (2.3×10^{-7} ppm)
Frequency Setting / Offsets ¹	Any frequency within band, with 1Hz setting increments
Frequency Response Variation	0.2dB, typical
Group Delay	2nS, typical
Phase Noise	10Hz ≤ -55 dBc/Hz 100Hz ≤ -85 dBc/Hz 1kHz ≤ -90 dBc/Hz 10kHz ≤ -95 dBc/Hz 100kHz ≤ -112 dBc/Hz 1MHz ≤ -130 dBc/Hz
Spurious Output ²	In Band -68dB (-45dB as measured in 30kHz RBW) Adjacent channels -68dB (-45dB as measured in 30kHz RBW) All others -40dB
Modulation Error Ratio (MER)	38dB, typical
Central Carrier Suppression	>75dB relative to average power
Out of Band Shoulders	>50dB, uncorrected, at rated average power

Note:

¹ High-stability external 10MHz/1PPS reference, or optional built-in GNSS receiver required for SFN

² Signals referenced to center channel, at rated output power, measured with 30kHz RBW



TV Transmitter Technical Engineering Data Sheet

Transmitter Type: VAXTE-16 VHF, Air Cooled, Solid State Transmitter, 16 Power Block System
2 X 37RU Rack

<u>Electrical Data:</u>	TV	DAB
RF Out Put Line Size:	3-1/8" unflanged	3-1/8" unflanged
Power Amplifier Type:	VHF Band A PA Pallet	VHF Band A & B PA Pallet
Frequency Range:	168-216 Mhz	168-242 Mhz
Nominal Pre Mask Filter RF Power Output	12800W *	16000W *
Quantity of PA Blocks:	16	16
Typical Power Consumption	~34.1 KVA	~40.5 KVA
Power Factor:	>0.95	>0.95
AC Main Currents (208V 1 Phase)***	164.0Amp	195.0Amp
AC Main Currents (208V 3 Phase)***	113.0Amp	134.0Amp
AC Main Currents (380V 3 Phase)***	62.0Amp	73.0Amp
See Notes***		

AC Main Configurations: 220-240 Single Phase, 208V to 240V (3) Wire or 380V to 415V (4) Wire (with Neutral)
 Earthing / Grounding: AC safety ground via third wire of mains inlets (PE green wire). AC safety ground should have unbroken connection back to earth post at mains distribution panel. Threaded ground stud provided on rear of amplifier chassis for connection to rack buss-bar where required by prevailing safety norms. Connection should be via unpainted surfaces and soldered/brazed for low resistance.

	<u>TV Band A PA</u>	<u>DAB Band A & B</u>	<u>TV Band A PA</u>	<u>DAB Band A & B</u>
Main breaker (208-240V 1P):	250.0Amp	300.0Amp	Cabinet breaker (208-240V 1P): 120.0Amp	140.0Amp
Main breaker (208-240V 3P):	160.0Amp	200.0Amp	Cabinet breaker (208-240V 3P): 80.0Amp	100.0Amp
Main breaker (380-415V 3P):	100.0Amp	100.0Amp	Cabinet breaker (380-415V 3P): 50.0Amp	50.0Amp

Cooling System:
 Cooling system Type: Air Cooled
 Air Flow: 123.1 m3/min (4348 ft3/min)
 Exhaust air Temperature Rise: 20°C

Environmental:

	<u>TV</u>	<u>DAB</u>
Transmitter operating Temperature:	0 to 45° C	
Transmitter Latent Heat to the Room: (At 25°C Room Ambient):	~20220W	~23275W
Transmitter Noise to the room:	=<65dBA	

Mechanical:

Transmitter Cabinet Dimensions:	Width 59.52cm(23.43in)	Single Drive/exciter	
2 X 37RU Rack:	Height 188.52cm(74.22in)	Transmitter Weight in Rack:	742 kg (1637 lbs)
	Depth 93.58cm(36.84in)	Cabinet Clearance:	1 meter (front and back)

See GatesAir Engineering for additional details.

*Power level varies with frequency for the broadband/ wide band pallet.

**The efficiency changes with frequency and power level.

*** Load is distributed using phase to phase or phase to Neutral, utilizing all 3 phases. High Leg Values are show when there is an Un-Balanced Load.

Technical data is subject to change at any time without notification, GatesAir takes no responsibility for issues caused by the data provided.

Local or national laws and electrical codes may also require changes to the data provided and should be reviewed.



Drawings

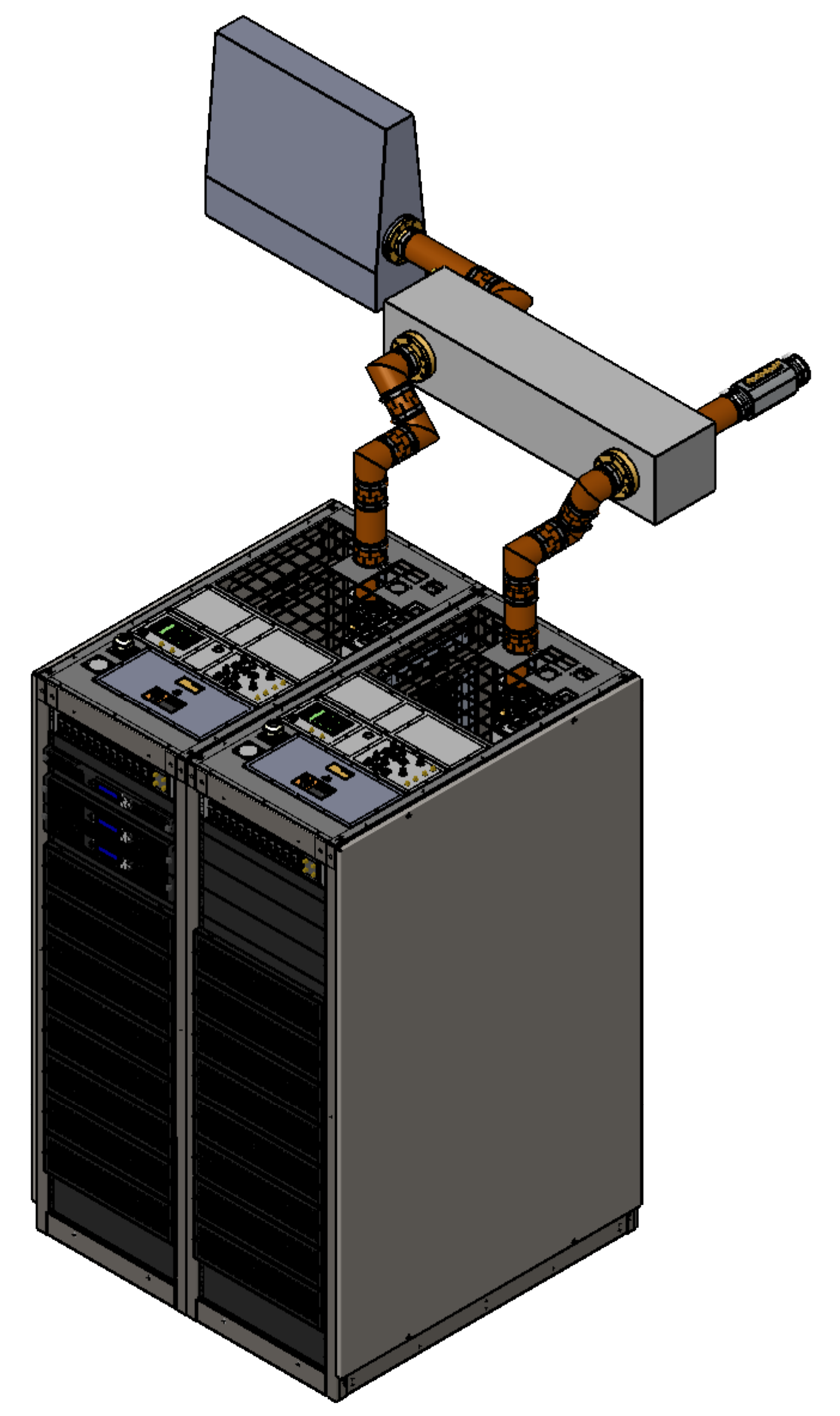
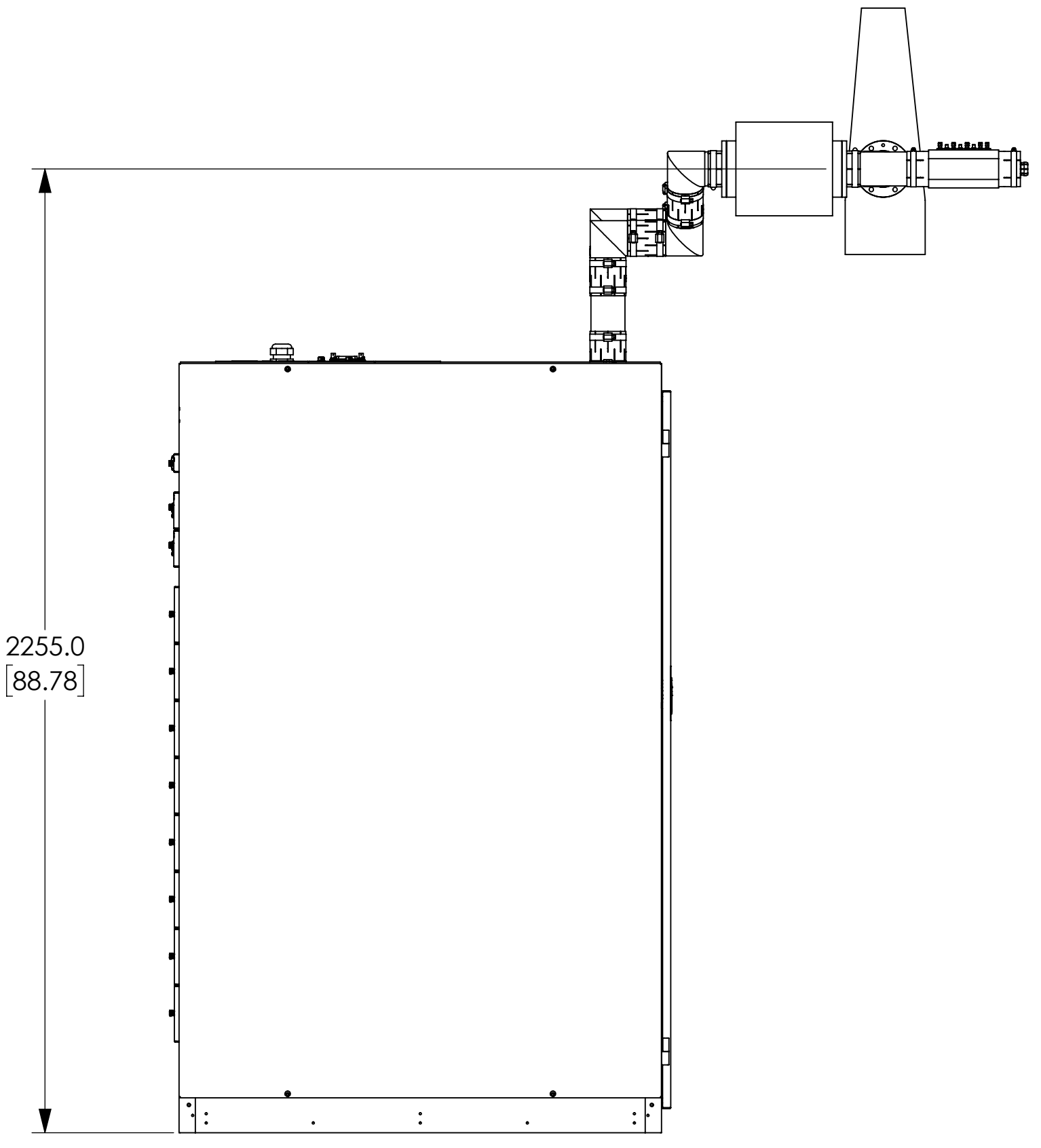
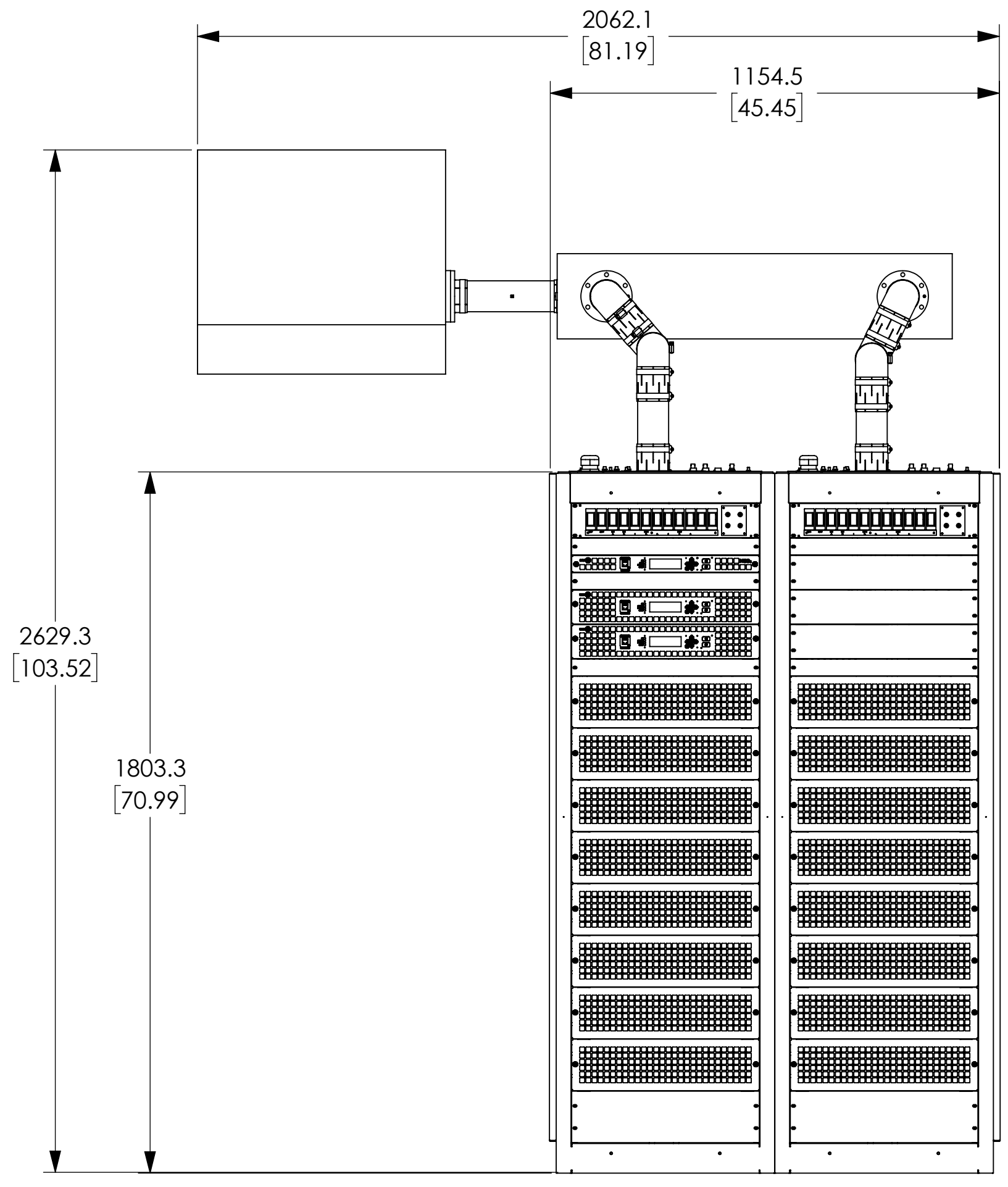
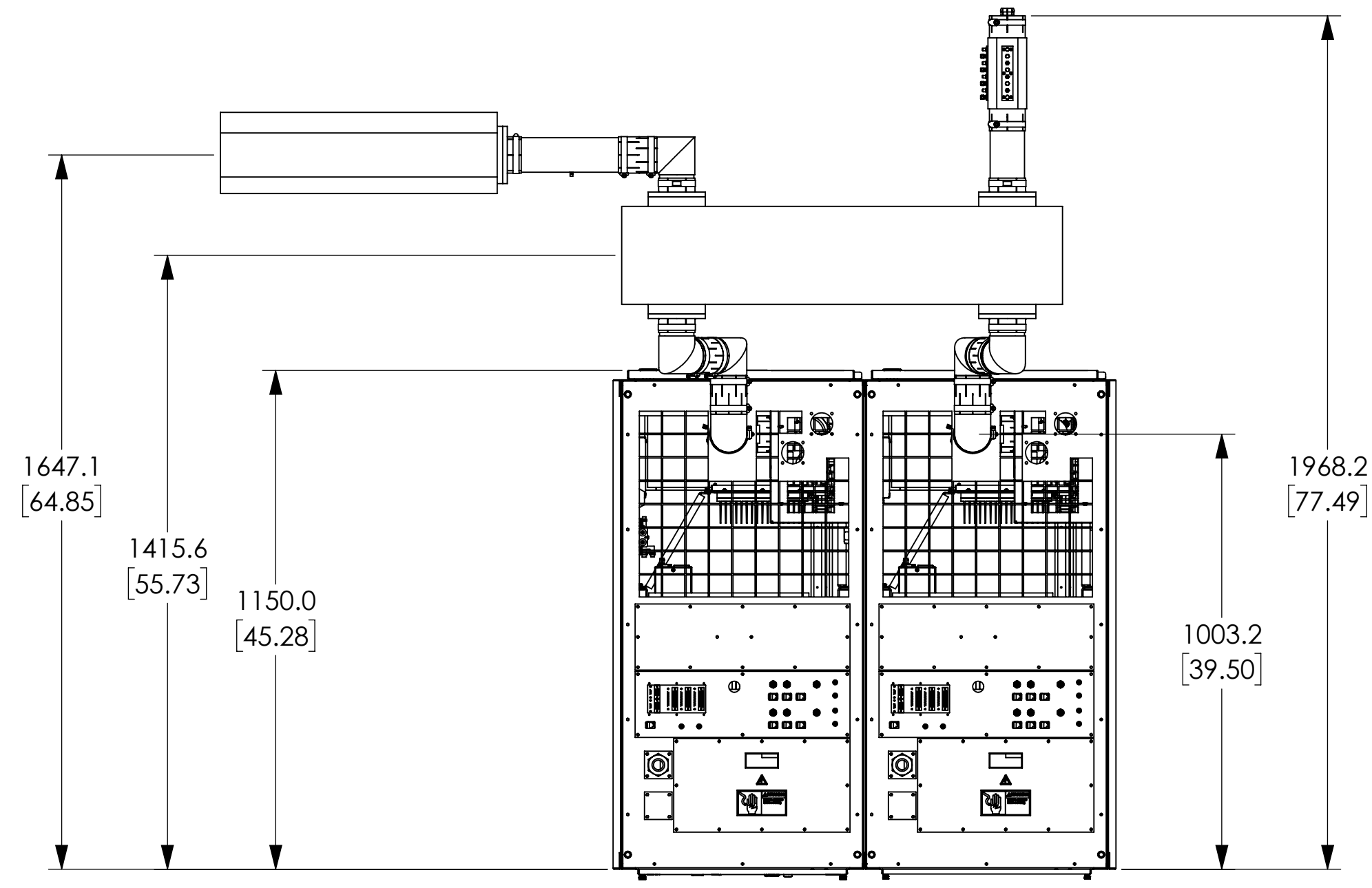

CABINET 1 CABINET 2

ROHS COMPLIANT PER DIRECTIVE 2002/95/EC

DWG SCALE: 1:12

TOLERANCES UNLESS NOTED
 .X ±0.38 .XX ±0.13
 HOLES ±0.13 ANGLES ±1°
 ALL √ INDICATES 3.2 MICROMETERS

ALL DIMENSIONS IN MILLIMETERS (INCHES)
 UNLESS OTHERWISE NOTED

MUST COMPLY WITH WORKMANSHIP
 STANDARDS SPEC 817-1152-001

NOTES	SUBJECT TO CHANGE						
	R	LTR	ZONE	DATE	DFTM	ENG	ECO NBR
	B			02-26-18	DSR		P63011
	UPDATED TO SHOW NEW ERI COMBINERS WITH UPDATED DIMS						
A1			11-13-17	DSR		P62253	
CHANGED OVERALL HEIGHT DIM FOR REJECT LOAD							

THIS DOCUMENT CONTAINS PROPRIETARY DATA OF
GatesAir, Inc.
 NO DISCLOSURE, REPRODUCTION, OR USE OF ANY
 PART THEREOF MAY BE MADE EXCEPT BY WRITTEN PERMISSION

DRAWN BY	S ROSENBALM	TITLE:	LAYOUT, CABINET, VAXTE-16	
DATE	06-07-2017	GATESAIR P/N:	9950209001	
MECH CHK	S ROSENBALM	DWG NO.:	8950209001	REV B
PROJ ENG	C STOTTS	SHEET	1 OF 1	
MFG ENG	S CORNWELL			



Company Information



GatesAir efficiently leverages wireless spectrum to maximize performance for multichannel TV and radio services, offering the industry's broadest portfolio helping broadcasters wirelessly deliver and monetize content. With nearly 100 years in broadcasting, GatesAir's exclusive focus on the over-the-air market helps broadcasters optimize services today and prepare for future revenue-generating business opportunities. All research, development and innovation is driven from the company's facilities in Mason, Ohio and fulfilled by the long-standing manufacturing center in Quincy, Illinois.

GatesAir's turnkey solutions are built on three pillars: Create, Transport and Transmit. The company is best known for powering over-the-air analog and digital radio/TV stations and networks worldwide with the industry's most operationally efficient transmitters. Ground-breaking innovations in low, medium and high-power transmitters reduce footprint, energy use and more to establish the industry's lowest total cost of ownership. Support for all digital standards and convergence with mobile networks ensure futureproof systems.

In television, GatesAir supplies proven, trusted wireless UHF and VHF solutions across all power requirements to support single-station over-the-air broadcasters on up to large national networks. The industry's most reliable software-definable exciters ensure broadcasters can optimize analog networks and quickly transition to digital TV in the field, with support for all major global DTV standards. GatesAir also supplies a wide array of over-the-air accessories to maximize transmitter control, network redundancy and signal compliance – along with installation, commissioning and ongoing support services – to deliver the industry's strongest turnkey approach for customers worldwide.

GatesAir has a well-established, on-the-ground presence in markets around the world. Every day, our more than 300 employees strive to deliver world-class solutions and service to customers in more than 130 countries. And we staff dozens of sales and support facilities in markets as diverse as France, Germany, China, Argentina, Mexico, Singapore, Australia and Dubai. This round-the-world presence ensures that every customer feels comfortable doing business with GatesAir.

In May 2019, GatesAir announced its purchase of ONEtastic S.r.l., a leading provider of television and digital radio transmission systems based in Brescia, Italy. The addition of the ONEtastic catalog to GatesAir's Maxiva product line expanded its offerings and innovative capabilities. ONEtastic's strength in high-efficiency, low-power TV and DAB radio transmitters also helped GatesAir better address the needs of large-scale over-the-air networks worldwide. The acquisition also strengthened GatesAir's growing presence and visibility in Europe.

Contact Information

+1 513 459 3400

Americas

Americas@gatesair.com

Europe, Middle East
Asia and Africa

+33 1 47 92 44 20
EMEA-APAC@gatesair.com

For more information, please visit gatesair.com

Global Service Locations



Meeting Customer Requirements

GatesAir is a company that can serve any need — from a single component to the design and deployment of an entire facility. Customers who partner with GatesAir not only gain access to the industry's broadest technology portfolio, they also gain access to a team of industry insiders who will collaborate to specify a broadcast operation's technology requirements by business outcomes — enabling broadcast operations to work smarter, faster and more profitably.

Technology Innovation

For nearly a century, GatesAir has pioneered the technologies that drive the world's leading television and radio broadcast operations. Our legacy of innovation has earned us nearly 250 global patents and more than 50 industry awards. From developing the world's first digital broadcast FM exciter, to helping launch the first commercial DTV station in the U.S., to enabling the first TV broadcast of a sporting event in 3D, GatesAir innovation helps our global customers keep pace with a continually evolving market.

Company Ownership

GatesAir is a portfolio company of The Gores Group, a global investment firm headquartered in Los Angeles, California. Founded in 1987, The Gores Group has approximately \$3.3 billion in assets under management and a diverse portfolio that includes technology, telecommunications, business services, industrial, health-care, media & entertainment, and consumer products.

The Gores Group collaborates closely with portfolio companies to establish viable operational blueprints, launch marketing and product initiatives and determine areas to invest for growth, to build stronger and better companies. For more information, please visit www.gores.com

Global Service and Support

GatesAir provides unrivaled long-term customer support for users of GatesAir-branded hardware and GatesAir-developed software solutions, as well as GatesAir-distributed equipment.

One of the most compelling reasons for selecting broadcast equipment from GatesAir is the level of support you will receive. We call it sustaining support, because its purpose is to sustain your equipment to a level that provides the highest return on your investment. We also want to sustain your confidence in GatesAir as your preferred supplier.

Service Bulletins

Service bulletins are produced to make customers aware of performance improvement, field modifications requirements and other corrective measures when it is considered to be of significant importance to the operation and performance of the equipment. GatesAir sends the bulletins to the original purchaser or if known, to the current user of the product in question. All bulletins are kept on file in the event there is a request for all bulletins of a particular model.

Update Kits

In addition to the service bulletins mentioned above, GatesAir makes available update parts kits that may be purchased by customers wishing to keep their equipment up-to-date. In cases where the updates involve issues of safety or necessary corrections to meet specifications, the kits are provided at no cost to the end user.

Hardware and Equipment

Our customers can call Field Service during our regular business hours, 8-5 M-F. Customers who require off-air emergency support can call 24 hours a day, 7 days a week and be connected with an on-call engineer. Call +1 217-222-8200 or e-mail: tsupport@gatesair.com; tsupport.europe@gatesair.com; tsupport.asia@gatesair.com

On Hand for Timely Delivery

Need something repaired? Notify the service support center for your product and region and call us for a RMA so we know it is coming. The GatesAir in-house technical repair facility provides our customers with the best repair, refurbishment, and upgrade opportunities available. Staffed by technically expert and product knowledgeable engineers and technicians, we perform services ranging from simple troubleshooting and component replacement to complete overhauls and refurbishments of all types of equipment. Our process includes testing your equipment using original factory test procedures. No repaired equipment will be returned until it performs to "as new" functionality or we will contact you to explain the problem and work out an alternative course of action. Need short term replacement modules? Our services also include a rental program, which enables you to stay on the air while your equipment is being repaired. We have over 60 modules available for rent to support the vast majority of GatesAir –built equipment in service. For a complete list of rental equipment please contact the repair call center at 1-888-534-8246.

Onsite Support

When it's critical to have an added level of onsite support, GatesAir has an experienced team ready to assist you:

- ✦ Diagnose, troubleshoot, calibrate and check network interoperability
- ✦ Maintain, proof or evaluate current and existing systems
- ✦ Customize onsite support packages specifically to your needs.

Specialized Services

Onsite Field Checkout Commissioning Services: One of our trained engineers will review and verify that your installation meets manufacturer specifications. They will ensure product integration and interfaces for interoperability, and make sure your new or existing project gets online quickly.

GoLive Support Services: For on-air cutovers or system launches. Arrange to have a factory-trained specialist onsite when your system goes live to make sure you have the support you need while you perform this critical operation.

Radio and Television Transmission Services: GatesAir's highly trained, highly experienced staff has installed, commissioned and maintained hundreds of radio and television transmitters worldwide. Transmission onsite field engineers from GatesAir provide these ongoing transmission services:

- ✦ Turnkey installations
- ✦ Installation assistance and commissioning
- ✦ Preventive and after-warranty maintenance
- ✦ Troubleshooting and equipment repair
- ✦ Program Management

Support Pre-staging

Factory pre-staging is available on large system installs and makes sure everything is working as a complete system before it gets shipped to a remote location. It also reduces onsite setup time. Customers may preview their systems in person by visiting the factory for a Factory Acceptance Test.

Interoperability

Understanding how your existing products will operate with new products is one of the key components to ensuring your systems' interoperability. At GatesAir we recognize this is critical to the build-out success, so we've defined a group of pre-qualified product, guaranteed to be interoperable. Whether your product came from GatesAir or from another third-party provider, GatesAir will test and evaluate the interoperability of those products, before you've designed the complete system. This is the GatesAir Interoperability Evaluation Service. For more information, contact us.

Project Management

Make your next project a huge success with GatesAir's project management services. GatesAir Professional Services allows your organization to leverage our technology leadership, project management, and broadcast and media expertise to build and grow your business. Whether you are upgrading or expanding your current plant, designing a disaster recovery solution, building a new facility, or re-engineering your workflows, GatesAir has consultants that can help you plan and deliver successful projects.

Training

Investing in the industry's most advanced and dependable broadcasting equipment is the first step to building a reliable and efficient operation. The second is securing the knowledge your team needs to maintain and operate your equipment at peak performance. GatesAir is also the only manufacturer to sponsor a training center with a full complement of general training classes as well as GatesAir product courses. Customized training is also available.

International Training

As part of our commitment to helping broadcasters around the world, GatesAir offers an annual two-week training session for broadcast engineers from developing nations. This program is a joint effort between GatesAir and the United States Telecommunications Training Institute (USTTI). Since 1983 over 250 engineers from 60 countries have participated in this program.

Service Agreements

GatesAir Service agreements ensure your products are supported after their standard warranty period expires. Have your service in place to take over when your warranty expires. GatesAir offers multiple levels of Services to fit your individual needs. Let us help you find the right level of support coverage.

GatesAir performs services ranging from simple troubleshooting and component replacement to complete overhauls and refurbishments of all types of equipment. Staffed by expert engineers and technicians, our process includes testing your equipment using original factory test procedures. GatesAir also offers a rental program, which enables you to stay on the air while your equipment is being repaired. We have modules available for rent to support the vast majority of GatesAir-built equipment in service.

World's Largest Transmitter Facilities!

Meeting customer requirements for delivery and quality is foremost for Gatesair. GatesAir maintains an ISO9001 registered transmitter manufacturing facility in Quincy, IL USA.

Several buildings in the Quincy location are dedicated to manufacturing. The main manufacturing building at 30th and Wismann Lane is 125,000 square feet and houses the following functions: Sheet Metal and Machine Shop, Printed Wiring Board Assembly and Test, Cable Assembly, High Power Module Assembly and Test, L-Band/UHF/VHF Product Assembly and Test and FM Radio Product Assembly and Test. There are three leased buildings totaling 55,000 square feet used for AM Radio Product Assembly and Test and Phasor/Antenna Control Unit Assembly and Test. These buildings are located 3 miles north of the main manufacturing facility.

Beyond the manufacturing space in Quincy, Illinois there is a 100,000 square foot administrative building which houses Manufacturing Engineering, Finance, Order Administration, Service, Service Parts, Sales Support and the Order Administration functions. There is also a separate 15,000 square feet building where technical training courses are offered to customers.

Production capacity

In any given day, there are approximately 15 different models of transmitters simultaneously being assembled and tested at the Quincy, Illinois manufacturing facilities:

- FM transmitters, a mix of solid state and tube units
- VHF transmitters, all solid state
- UHF transmitters, all solid state
- L-Band transmitters, all solid state

The mix and volume of product coming out of the GateAir factory is unmatched by any other transmitter manufacturer. The operation runs one full shift per day. There are only a couple of areas where there are 2 shifts running today, so future needs for expanded output will come from more personnel working on a second shift.

\$2-3 million of capital is invested in the Manufacturing operation each year. All GatesAir manufacturing plants are a subject of continuous improvement and capital investment. Most of the capital investment is driven by new technologies, new products and efficiency improvements for the operation. Formal customer acceptance is an option available that demonstrates the product performing to specification, at the same time, giving the customer an opportunity to confirm confidence by inspecting the manufacturing process.

Quality

GatesAir manufacturing facilities have been ISO 9001 registered since December 1994. There is a comprehensive and documented quality system in place that covers all major facets of the operation: the management review process, product design, order administration, inspections, all manufacturing operations, purchasing, equipment calibration, and training. This system is monitored through an on-going internal and external audit program.

There is an intense focus on improving the manufacturing operation. A team of 10-15 people work to transform and change an area. The team is given a very specific mandate on what goals need to be achieved. The team is trained on some very specific principles, which will help them achieve the goals: once piece flow, waste identification and removal, spaghetti diagrams, kanban pull systems, and workplace organization. The team then implements the changes.

To ensure transmitters are manufactured under the most exacting conditions, GatesAir has voluntarily sought and achieved ISO Quality Standard registration. GatesAir is registered with current certification on file for the following manufacturing, testing, environmental and quality standards: ISO 9001:2008 – Certificate of Registration of Quality Management System; ISO 14001:2004 – Certificate of Registration of Environmental Management System; OSHAS 18001:2007 – Certificate of Registration of Occupational Health and Safety Management System

RoHS – All products/parts/materials offered conform fully with Directive 2011/65/EU – European Union (EU) Restriction on Hazardous Substances – sets limits on the use of restricted substances found in electronic equipment: Lead (Pb), Mercury (Hg), Cadmium (Cd), Hexavalent Chromium (Cr-VI), Polybrominated Biphenyls (PBB), Polybrominated Diphenyl Ethers (PBDE).

WEEE Directive – HBC is fully compliant with EU Directive 2002/96/EC– The European Union Directive on Waste from Electrical and Electronic Equipment

Shipping

Our shipping and packing department is the best in the world for getting the orders to the customer on time and undamaged. The Shipping department ships product to over 100 countries each year. There is extensive traffic knowledge on how to ship product anywhere in the world using almost any mode of transportation. The packing and crating for all shipments (domestic and international) is done in-plant. The knowledge gained in preparing shipments for international shipment over the past 40 years is important to making sure the equipment arrives in good condition.



NSAI

Certificate of Registration of Occupational Health and Safety Management System to BS OHSAS 18001:2007

The National Standards Authority of Ireland certifies that:

GatesAir, Inc.
3200 Wismann Lane
Quincy, IL 62305
USA

has been assessed and deemed to comply with the requirements of the above standard in respect of the scope of operations given below:

Manufacturing, Order Management, Program Management, Supply Chain Management, Sustaining Engineering and Repair of Radio, Television, and Networking Products for use in Broadcast Communications and Related Media Industries.

Approved by:
Geraldine Larkin
Chief Executive Officer

Approved by:
Lisa Greenleaf
Operations Manager

Registration Number: 18.4117X
Certification Granted: September 04, 2007
Effective Date: February 23, 2019
Expiry Date: March 12, 2021



National Standards Authority of Ireland, 20 Trafalgar Square, Nashua, New Hampshire, NH 03063, USA T +1 603 882 4412



NSAI

Certificate of Registration of Quality Management System to ISO 9001:2015

The National Standards Authority of Ireland certifies that:

GatesAir, Inc.
3200 Wismann Lane
Quincy, IL 62305
USA

has been assessed and deemed to comply with the requirements of the above standard in respect of the scope of operations given below:

Manufacturing, Order Management, Program Management, Supply Chain Management, Sustaining Engineering and Repair of Radio, Television, and Networking Products for use in Broadcast Communications and Related Media Industries.

Approved by:
Geraldine Larkin
Chief Executive Officer

Approved by:
Lisa Greenleaf
Operations Manager

Registration Number: 19.1841/A
Certification Granted: December 22, 1994
Effective Date: February 23, 2019
Expiry Date: February 22, 2022



National Standards Authority of Ireland, 20 Trafalgar Square, Nashua, New Hampshire, NH 03063, USA T +1 603 882 4412



NSAI

Certificate of Registration of Environmental Management System to ISO 14001:2015

The National Standards Authority of Ireland certifies that:

GatesAir, Inc.
3200 Wismann Lane
Quincy, IL 62305
USA

has been assessed and deemed to comply with the requirements of the above standard in respect of the scope of operations given below:

Manufacturing, Order Management, Program Management, Supply Chain Management, Sustaining Engineering and Repair of Radio, Television, and Networking Products for use in Broadcast Communications and Related Media Industries.

Approved by:
Geraldine Larkin
Chief Executive Officer

Approved by:
Lisa Greenleaf
Operations Manager

Registration Number: 14.4127X
Certification Granted: September 04, 2007
Effective Date: February 23, 2019
Expiry Date: February 22, 2022



National Standards Authority of Ireland, 20 Trafalgar Square, Nashua, New Hampshire, NH 03063, USA T+1 603 882 4412