

Service Pump & Supply  
1111 Vernon Street  
Huntington, WV 25704

Phone: 304-429-6731  
Fax: 304-429-3005

www.servicepump.com



**Fax**

**To:** Melissa Pettrey **From:** Randy Doss

---

**Company:** WV Dept of Administration, General Services Division **Phone:** 304-429-6731-155

---

**Phone:** (304) 558-0094 **Fax:** 304-429-6736

---

**Fax:** (304) 558-3970 **Cell:** 304-208-5854

---

**E-mail:** melissa.k.pettrey@wv.gov **E-mail:** randydoss@servicepump.com

---

**Re:** CRFQ 0211 GSD2000000023

---

Service Pump Quote Q-0000009193 Rev 0

---

Sealed Bid	Water Pump/Motor Skid Replacement
Buyer	Melissa K. Pettrey - Senior Buyer
Solicitation	CRFQ 0211 GSD2000000023
Bid Opening Date	1/31/2020
Bid Opening Time	1:30 PM
Fax Number	304-558-3970

Contents:

WV-PRC-CRFQ-001

Addendum Acknowledgement Form

Contractors License

WV PURCHASING  
DIVISION

2020 JAN 30 PM 3:09

RECEIVED

Subcontractor List

Designated Contact/Certification and Signature

Contract Manager

Pricing Page

Purchasing Affidavit

Fixed Period Contract \*\*\*EXCEPTION\*\*\*

Insurance

Job Safety Handbook acknowledgement

Drug Free Workplace Affidavit

Bid Bond

Vendor Preference Certificate

Please call if you have any questions.

Regards,

Randy Doss



Purchasing Division  
2019 Washington Street East  
Post Office Box 50130  
Charleston, WV 25305-0130

State of West Virginia  
Request for Quotation  
09 - Construction

Proc Folder: 673207

Doc Description: Addendum No. 1 Water Pump/Motor Skid Replacement

Proc Type: Central Purchase Order

Date Issued	Solicitation Closes	Solicitation No	Version
2020-01-17	2020-01-31 13:30.00	CRFQ 0211 GSD2000000023	2

**BID RECEIVING LOCATION**

BID CLERK  
DEPARTMENT OF ADMINISTRATION  
PURCHASING DIVISION  
2019 WASHINGTON ST E  
CHARLESTON WV 25305  
US

**VENDOR**

**Vendor Name, Address and Telephone Number:**

Service Pump & Supply  
1111 Vernon St  
Huntington, WV 25705  
304-429-6731

**FOR INFORMATION CONTACT THE BUYER**

Melissa Pettrey  
(304) 558-0094  
melissa.k.pettrey@wv.gov

Signature X

FEIN # 55-0599012

DATE 01/30/2020

All offers subject to all terms and conditions contained in this solicitation

**ADDITIONAL INFORMATION:**

Addendum No. 1

Addendum No. 1 is issued to publish and distribute the attached information to the vendor community

Request for Quotation  
Construction

The West Virginia Purchasing Division is soliciting bids on behalf of the WV Department of Administration, General Services Division to establish a contract for the purchase and installation of one (1) Water Pump/Motor Skid replacement per the bid requirements, specifications, terms and conditions attached herein.

INVOICE TO	SHIP TO
DEPARTMENT OF ADMINISTRATION GENERAL SERVICES DIVISION 112 CALIFORNIA AVENUE, 5TH FLOOR CHARLESTON WV25305 US	DEPARTMENT OF ADMINISTRATION GENERAL SERVICES DIVISION BLDG 11 - CHILLER PLANT 218 CALIFORNIA AVE CHARLESTON WV 25305 US

Line	Comm Ln Desc	Qty	Unit Issue	Unit Price	Total Price
1	Water Pump/Motor Skid Replacement	1 00000	LS	\$41,235.00	\$41,235.00

Comm Code	Manufacturer	Specification	Model #
83101510	Bell & Gossett	Double Suction Pump	VSCS-6X8X13

Extended Description :

Water Pump/Motor Skid Replacement per attached specifications

Suction Diffuser Aurora SD1008

Bell & Gossett VSCS-8 X 8 X 9 1/4 is obsolete

Exception: Project cannot be completed in 14 days due to lead time on pump skid.

**ADDENDUM ACKNOWLEDGEMENT FORM**  
**SOLICITATION NO.: GSD2000000023**

**Instructions:** Please acknowledge receipt of all addenda issued with this solicitation by completing this addendum acknowledgment form. Check the box next to each addendum received and sign below. Failure to acknowledge addenda may result in bid disqualification.

**Acknowledgment:** I hereby acknowledge receipt of the following addenda and have made the necessary revisions to my proposal, plans and/or specification, etc.

**Addendum Numbers Received:**

(Check the box next to each addendum received)

- |  |  |
|--|--|
| <input checked="" type="checkbox"/> Addendum No. 1 | <input type="checkbox"/> Addendum No. 6  |
| <input type="checkbox"/> Addendum No. 2            | <input type="checkbox"/> Addendum No. 7  |
| <input type="checkbox"/> Addendum No. 3            | <input type="checkbox"/> Addendum No. 8  |
| <input type="checkbox"/> Addendum No. 4            | <input type="checkbox"/> Addendum No. 9  |
| <input type="checkbox"/> Addendum No. 5            | <input type="checkbox"/> Addendum No. 10 |

I understand that failure to confirm the receipt of addenda may be cause for rejection of this bid. I further understand that that any verbal representation made or assumed to be made during any oral discussion held between Vendor's representatives and any state personnel is not binding. Only the information issued in writing and added to the specifications by an official addendum is binding.

Service Pump & Supply

Company

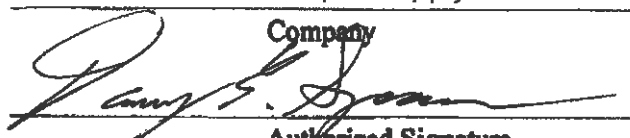

Authorized Signature

01/30/2020

Date

**NOTE:** This addendum acknowledgment should be submitted with the bid to expedite document processing.

**ADDITIONAL TERMS AND CONDITIONS (Construction Contracts Only)**

**i. CONTRACTOR'S LICENSE:** West Virginia Code § 21-11-2 requires that all persons desiring to perform contracting work in this state be licensed. The West Virginia Contractors Licensing Board is empowered to issue the contractor's license. Applications for a contractor's license may be made by contacting the West Virginia Division of Labor. West Virginia Code § 21-11-11 requires any prospective Vendor to include the contractor's license number on its bid. If an apparent low bidder fails to submit a license number in accordance with this section, the Purchasing Division will promptly request by telephone and electronic mail that the low bidder and the second low bidder provide the license number within one business day of the request. Failure of the bidder to provide the license number within one business day of receiving the request shall result in disqualification of the bid. Vendors should include a contractor's license number in the space provided below.

Contractor's Name: Service Pump & Supply

Contractor's License No.: WV- 015048

The apparent successful Vendor must furnish a copy of its contractor's license prior to the issuance of a contract award document.

**2. DRUG-FREE WORKPLACE AFFIDAVIT:** W. Va. Code § 21-1D-5 provides that any solicitation for a public improvement contract requires each Vendor that submits a bid for the work to submit an affidavit that the Vendor has a written plan for a drug-free workplace policy. If the affidavit is not submitted with the bid submission, the Purchasing Division shall promptly request by telephone and electronic mail that the low bidder and second low bidder provide the affidavit within one business day of the request. Failure to submit the affidavit within one business day of receiving the request shall result in disqualification of the bid. To comply with this law, Vendor should complete the enclosed drug-free workplace affidavit and submit the same with its bid. Failure to submit the signed and notarized drugfree workplace affidavit or a similar affidavit that fully complies with the requirements of the applicable code, within one business day of being requested to do so shall result in disqualification of Vendor's bid. Pursuant to W. Va. Code 21-1D-2(b) and (k), this provision does not apply to public improvement contracts the value of which is \$100,000 or less or temporary or emergency repairs.

**2.1. DRUG-FREE WORKPLACE POLICY:** Pursuant to W. Va. Code § 21-1D-4, Vendor and its subcontractors must implement and maintain a written drug-free workplace policy that complies with said article. The awarding public authority shall cancel this contract if: (1) Vendor fails to implement and maintain a written drug-free workplace policy described in the preceding paragraph, (2) Vendor fails to provide information regarding implementation of its drug-free workplace policy at the request of the public authority; or (3) Vendor provides to the public authority false information regarding the contractor's drug-free workplace policy.

Pursuant to W. Va. Code 21-1D-2(b) and (k), this provision does not apply to public improvement contracts the value of which is \$100,000 or less or temporary or emergency repairs.

# CONTRACTOR LICENSE

Authorized by the

## West Virginia Contractor Licensing Board

**Number:** WV015048

**Classification:**  
SPECIALTY

SERVICE PUMP & SUPPLY CO INC  
DBA SERVICE PUMP & SUPPLY CO INC  
PO BOX 2097  
HUNTINGTON, WV 25721-2097

**Date Issued**

**Expiration Date**

OCTOBER 15, 2019

OCTOBER 15, 2020

  
Authorized Company Signature

  
Chair, West Virginia Contractor  
Licensing Board

**WEST VIRGINIA  
CONTRACTOR  
LICENSING  
BOARD**

This license, or a copy thereof, must be posted in a conspicuous place at every construction site where work is being performed. This license number must appear in all advertisements, on all bid submissions and on all fully executed and binding contracts. This license cannot be assigned or transferred by licensee. Issued under provisions of West Virginia Code, Chapter 21, Article 11.





**DESIGNATED CONTACT:** Vendor appoints the individual identified in this Section as the Contract Administrator and the initial point of contact for matters relating to this Contract.

  
 \_\_\_\_\_  
 (Name, Title)  
 Sean Farrell - Professional Engineer  
 \_\_\_\_\_  
 (Printed Name and Title)  
 1111 Vernon Street Huntington WV 25704  
 \_\_\_\_\_  
 (Address)  
 304-429-6731/304-429-6736  
 \_\_\_\_\_  
 (Phone Number) / (Fax Number)  
 seanfarrell@servicepump.com  
 \_\_\_\_\_  
 (email address)

**CERTIFICATION AND SIGNATURE:** By signing below, or submitting documentation through wvOASIS, I certify that I have reviewed this Solicitation in its entirety; that I understand the requirements, terms and conditions, and other information contained herein; that this bid, offer or proposal constitutes an offer to the State that cannot be unilaterally withdrawn; that the product or service proposed meets the mandatory requirements contained in the Solicitation for that product or service, unless otherwise stated herein; that the Vendor accepts the terms and conditions contained in the Solicitation, unless otherwise stated herein; that I am submitting this bid, offer or proposal for review and consideration; that I am authorized by the vendor to execute and submit this bid, offer, or proposal, or any documents related thereto on vendor's behalf; that I am authorized to bind the vendor in a contractual relationship; and that to the best of my knowledge, the vendor has properly registered with any State agency that may require registration.

Service Pump & Supply

(Company)

 **DANNY E. SPEARS VICE PRESIDENT**  
 \_\_\_\_\_  
 (Authorized Signature) (Representative Name, Title)

Danny Spears Vice President

(Printed Name and Title of Authorized Representative)

01/30/2020

(Date)

304-429-6731/304-429-6736

(Phone Number) (Fax Number)

**REQUEST FOR QUOTATION  
Water Pump/Motor Skid Replacement – Building 11**

---

**10.5.2.2.** Invoices shall be mailed to the following address:

General Services Division  
112 California Avenue, 5<sup>th</sup> Floor  
Charleston, WV 25305

**10.5.2.3.** Or, emailed to [GSDInvoices@wv.gov](mailto:GSDInvoices@wv.gov).

**11. FACILITIES ACCESS:** Performance of Contract Services may require access cards and/or keys to gain entrance to Agency's facilities. In the event that access cards and/or keys are required:

**11.1.** Vendor must identify principal service personnel which will be issued access cards and/or keys to perform service.

**11.2.** Vendor will be responsible for controlling cards and keys and will pay replacement fee, if the cards or keys become lost or stolen.

**11.3.** Vendor shall notify Agency immediately of any lost, stolen, or missing card or key.

**11.4.** Anyone performing under this Contract will be subject to Agency's security protocol and procedures.

**11.5.** Vendor shall inform all staff of Agency's security protocol and procedures.

**12. MISCELLANEOUS:**

**12.1. Contract Manager:** During its performance of this Contract, Vendor must designate and maintain a primary contract manager responsible for overseeing Vendor's responsibilities under this Contract. The Contract manager must be available during normal business hours to address any customer service or other issues related to this Contract. Vendor should list its Contract manager and his or her contact information below.

**Contract Manager:** Sean Farrell

**Telephone Number:** 304-429-6731

**Fax Number:** 304-429-6736

**Email Address:** seanfarrell@servicepump.com

**REQUEST FOR QUOTATION  
Water Pump/Motor Skid Replacement – Building 11**

---

**EXHIBIT A – Pricing Page**

**Lump Sum Price: to include all labor and materials to replace one (1) Water Pump/Motor Skid.**

**Lump Sum = \$ 41,235.00**

STATE OF WEST VIRGINIA
Purchasing Division
PURCHASING AFFIDAVIT

CONSTRUCTION CONTRACTS: Under W. Va. Code § 5-22-1(i), the contracting public entity shall not award a construction contract to any bidder that is known to be in default on any monetary obligation owed to the state or a political subdivision of the state, including, but not limited to, obligations related to payroll taxes, property taxes, sales and use taxes, fire service fees, or other fines or fees.

ALL CONTRACTS: Under W. Va. Code §5A-3-10a, no contract or renewal of any contract may be awarded by the state or any of its political subdivisions to any vendor or prospective vendor when the vendor or prospective vendor or a related party to the vendor or prospective vendor is a debtor and: (1) the debt owed is an amount greater than one thousand dollars in the aggregate; or (2) the debtor is in employer default.

EXCEPTION: The prohibition listed above does not apply where a vendor has contested any tax administered pursuant to chapter eleven of the W. Va. Code, workers' compensation premium, permit fee or environmental fee or assessment and the matter has not become final or where the vendor has entered into a payment plan or agreement and the vendor is not in default of any of the provisions of such plan or agreement.

DEFINITIONS:

"Debt" means any assessment, premium, penalty, fine, tax or other amount of money owed to the state or any of its political subdivisions because of a judgment, fine, permit violation, license assessment, defaulted workers' compensation premium, penalty or other assessment presently delinquent or due and required to be paid to the state or any of its political subdivisions, including any interest or additional penalties accrued thereon.

"Employer default" means having an outstanding balance or liability to the old fund or to the uninsured employers' fund or being in policy default, as defined in W. Va. Code § 23-2c-2, failure to maintain mandatory workers' compensation coverage, or failure to fully meet its obligations as a workers' compensation self-insured employer. An employer is not in employer default if it has entered into a repayment agreement with the Insurance Commissioner and remains in compliance with the obligations under the repayment agreement.

"Related party" means a party, whether an individual, corporation, partnership, association, limited liability company or any other form or business association or other entity whatsoever, related to any vendor by blood, marriage, ownership or contract through which the party has a relationship of ownership or other interest with the vendor so that the party will actually or by effect receive or control a portion of the benefit, profit or other consideration from performance of a vendor contract with the party receiving an amount that meets or exceeds five percent of the total contract amount.

AFFIRMATION: By signing this form, the vendor's authorized signer affirms and acknowledges under penalty of law for false swearing (W. Va. Code §61-5-3) that: (1) for construction contracts, the vendor is not in default on any monetary obligation owed to the state or a political subdivision of the state, and (2) for all other contracts, that neither vendor nor any related party owe a debt as defined above and that neither vendor nor any related party are in employer default as defined above, unless the debt or employer default is permitted under the exception above.

WITNESS THE FOLLOWING SIGNATURE:

Vendor's Name: Service Pump & Supply

Authorized Signature:

[Handwritten Signature]

Date: 01/30/2020

State of WV

County of Wayne, to-wit:

Taken, subscribed, and sworn to before me this 30 day of January, 2020.

My Commission expires January 14, 2020.

AFFIX SEAL HERE

NOTARY PUBLIC

[Handwritten Signature: Deanna Coulter]

Purchasing Affidavit (Revised 01/18/2018)

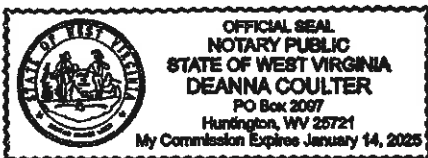

**3. CONTRACT TERM; RENEWAL; EXTENSION:** The term of this Contract shall be determined in accordance with the category that has been identified as applicable to this Contract below:

**Term Contract**

**Initial Contract Term:** Initial Contract Term: This Contract becomes effective on \_\_\_\_\_ and extends for a period of \_\_\_\_\_ year(s).

**Renewal Term:** This Contract may be renewed upon the mutual written consent of the Agency, and the Vendor, with approval of the Purchasing Division and the Attorney General's office (Attorney General approval is as to form only). Any request for renewal should be delivered to the Agency and then submitted to the Purchasing Division thirty (30) days prior to the expiration date of the initial contract term or appropriate renewal term. A Contract renewal shall be in accordance with the terms and conditions of the original contract. Unless otherwise specified below, renewal of this Contract is limited to \_\_\_\_\_ successive one (1) year periods or multiple renewal periods of less than one year, provided that the multiple renewal periods do not exceed the total number of months available in all renewal years combined. Automatic renewal of this Contract is prohibited. Renewals must be approved by the Vendor, Agency, Purchasing Division and Attorney General's office (Attorney General approval is as to form only)

**Alternate Renewal Term** -- This contract may be renewed for \_\_\_\_\_ successive \_\_\_\_\_ year periods or shorter periods provided that they do not exceed the total number of months contained in all available renewals. Automatic renewal of this Contract is prohibited. Renewals must be approved by the Vendor, Agency, Purchasing Division and Attorney General's office (Attorney General approval is as to form only)

**Delivery Order Limitations:** In the event that this contract permits delivery orders, a delivery order may only be issued during the time this Contract is in effect. Any delivery order issued within one year of the expiration of this Contract shall be effective for one year from the date the delivery order is issued. No delivery order may be extended beyond one year after this Contract has expired.

**Fixed Period Contract:** This Contract becomes effective upon Vendor's receipt of the notice to proceed and must be completed within FOURTEEN (14) days **EXCEPTION**

**Fixed Period Contract with Renewals:** This Contract becomes effective upon Vendor's receipt of the notice to proceed and part of the Contract more fully described in the attached specifications must be completed within \_\_\_\_\_ days. Upon completion of the work covered by the preceding sentence, the vendor agrees that maintenance, monitoring, or warranty services will be provided for \_\_\_\_\_ year(s) thereafter.

**One Time Purchase:** The term of this Contract shall run from the issuance of the Award Document until all of the goods contracted for have been delivered, but in no event will this Contract extend for more than one fiscal year.

**Other:** See attached.

**8. INSURANCE:** The apparent successful Vendor shall furnish proof of the insurance identified by a checkmark below and must include the State as an additional insured on each policy prior to Contract award. The insurance coverages identified below must be maintained throughout the life of this contract. Thirty (30) days prior to the expiration of the insurance policies, Vendor shall provide the Agency with proof that the insurance mandated herein has been continued. Vendor must also provide Agency with immediate notice of any changes in its insurance policies, including but not limited to, policy cancellation, policy reduction, or change in insurers. The apparent successful Vendor shall also furnish proof of any additional insurance requirements contained in the specifications prior to Contract award regardless of whether or not that insurance requirement is listed in this section.

Vendor must maintain:

- Commercial General Liability Insurance** in at least an amount of: \$1,000,000.00 per occurrence.
- Automobile Liability Insurance** in at least an amount of: \$1,000,000.00 per occurrence.
- Professional/Malpractice/Errors and Omission Insurance** in at least an amount of: \_\_\_\_\_ per occurrence. Notwithstanding the forgoing, Vendor's are not required to list the State as an additional insured for this type of policy.
- Commercial Crime and Third Party Fidelity Insurance** in an amount of: \$100,000.00 per occurrence.
- Cyber Liability Insurance** in an amount of: \_\_\_\_\_ per occurrence.
- Builders Risk Insurance** in an amount equal to 100% of the amount of the Contract.
- Pollution Insurance** in an amount of: \_\_\_\_\_ per occurrence.
- Aircraft Liability** in an amount of: \_\_\_\_\_ per occurrence.
- 
- 
- 
-

# EXHIBIT C

## Jobsite Safety Handbook

For Contractors

Department of Administration (DOA)

General Services Division (GSD)

112 California Avenue  
Building Four, 5<sup>th</sup> Floor  
Charleston, WV

THIS HANDBOOK IS TO BE POSTED IN A VISIBLE AREA AT ALL CONSTRUCTION  
PROJECTS AND/OR CONTRACTOR WORKSITES

Contractor Contact: DANNY SPEARS

Phone #: 304-429-6731/304-638-6731 Cell

### EMERGENCY CONTACTS:

Project Manager:

Name: Sean Farrell

Phone #: 304-429-6731/304-617-7434 Cell

Emergency Services #: 911

### GSD Safety Section:

112 California Ave, Bldg.4 5<sup>th</sup> Floor. Charleston, WV 25305

Jonathan Trout: Work# 304 957-7153 Cell# 304-205-2721

Marsha Bowling Work# 304-957-7154 Cell# 304-951-1410

Revision 2/6/19

**Contractor Acknowledgement:**

I, the undersigned, have read, reviewed and acknowledge my understanding of the General Services Division safety requirements, as set forth in this handbook. I am also aware that all applicable rules and regulations are to be followed, regardless of whether they are specifically mentioned in this handbook.

Contractor Representative (Print Name): Danny Spears

Contractor Representative Signature:  Date: 01/30/2020

This signed acknowledgement must be signed and returned to the GSD Safety Section prior to start of project work.



WV-73  
Approved / July 7, 2017



**State of West Virginia  
DRUG FREE WORKPLACE CONFORMANCE AFFIDAVIT  
West Virginia Code §21-1D-5**

**STATE OF WEST VIRGINIA,  
COUNTY OF Wayne, TO-WIT:**

I, Suzanne L. House, after being first duly sworn, depose and state as follows:

- 1. I am an employee of Service Pump & Supply; and,  
(Company Name)
- 2. I do hereby attest that Service Pump & Supply  
(Company Name)

maintains a written plan for a drug-free workplace policy and that such plan and policy are in compliance with **West Virginia Code §21-1D**.

The above statements are sworn to under the penalty of perjury.

Printed Name: Suzanne L. House  
 Signature: *Suzanne L. House*  
 Title: HR Manager  
 Company Name: Service Pump & Supply  
 Date: 01/30/2020

Taken, subscribed and sworn to before me this 30th day of January, 2020  
By Commission expires January 14, 2025

(Seal)

*Deanna Coulter*  
(Notary Public)

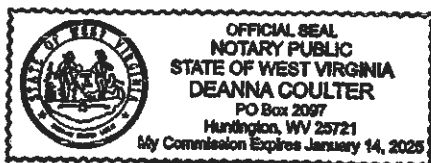

Agency WV Dept of Admin.  
REQ.P.O# GSD2000000023

**BID BOND**

KNOW ALL MEN BY THESE PRESENTS, That we, the undersigned, Service Pump & Supply Company, Inc.  
of Huntington, West Virginia, as Principal, and The Ohio Casualty Ins. Co.  
of Keene, New Hampshire, a corporation organized and existing under the laws of the State of New Hampshire with its principal office in the City of Keene, as Surety, are held and firmly bound unto the State of West Virginia, as Obligee, in the penal sum of Five percent of amount bid (\$ 5% of amount bid ) for the payment of which, well and truly to be made, we jointly and severally bind ourselves, our heirs, administrators, executors, successors and assigns.

The Condition of the above obligation is such that whereas the Principal has submitted to the Purchasing Section of the Department of Administration a certain bid or proposal, attached hereto and made a part hereof, to enter into a contract in writing for Addendum No. 1 Water Pump/Motor Skid Replacement

**NOW THEREFORE,**

- (a) If said bid shall be rejected, or
- (b) If said bid shall be accepted and the Principal shall enter into a contract in accordance with the bid or proposal attached hereto and shall furnish any other bonds and insurance required by the bid or proposal, and shall in all other respects perform the agreement created by the acceptance of said bid, then this obligation shall be null and void, otherwise this obligation shall remain in full force and effect. It is expressly understood and agreed that the liability of the Surety for any and all claims hereunder shall, in no event, exceed the penal amount of this obligation as herein stated.

The Surety, for the value received, hereby stipulates and agrees that the obligations of said Surety and its bond shall be in no way impaired or affected by any extension of the time within which the Obligee may accept such bid, and said Surety does hereby waive notice of any such extension.

WITNESS, the following signatures and seals of Principal and Surety, executed and sealed by a proper officer of Principal and Surety, or by Principal individually if Principal is an individual, this 30th day of January, 2020.

Principal Seal

Service Pump & Supply Company, Inc.  
(Name of Principal)

By [Signature]  
(Must be President, Vice President, or Duly Authorized Agent)

PRESIDENT  
(Title)

Surety Seal

The Ohio Casualty Insurance Company  
(Name of Surety)

[Signature]  
Attorney-in-Fact  
Amanda Colley

**IMPORTANT – Surety executing bonds must be licensed in West Virginia to transact surety insurance, must affix its seal, and must attach a power of attorney with its seal affixed.**

**THIS POWER OF ATTORNEY IS NOT VALID UNLESS IT IS PRINTED ON RED BACKGROUND.**

This Power of Attorney limits the acts of those named herein, and they have no authority to bind the Company except in the manner and to the extent herein stated.

Certificate No. 8186555

Liberty Mutual Insurance Company  
The Ohio Casualty Insurance Company West American Insurance Company

**POWER OF ATTORNEY**

KNOWN ALL PERSONS BY THESE PRESENTS: That The Ohio Casualty Insurance Company is a corporation duly organized under the laws of the State of New Hampshire, that Liberty Mutual Insurance Company is a corporation duly organized under the laws of the State of Massachusetts, and West American Insurance Company is a corporation duly organized under the laws of the State of Indiana (herein collectively called the "Companies"), pursuant to and by authority herein set forth, does hereby name, constitute and appoint, Thomas H. Bottoms Jr; Amanda Colley; Darlene Jones; Clarence C. Massey; Debra G. Roach

all of the city of Huntington, state of WV, each individually if there be more than one named, its true and lawful attorney-in-fact to make, execute, seal, acknowledge and deliver, for and on its behalf as surety and as its act and deed, any and all undertakings, bonds, recognizances and other surety obligations, in pursuance of these presents and shall be as binding upon the Companies as if they have been duly signed by the president and attested by the secretary of the Companies in their own proper persons.

IN WITNESS WHEREOF, this Power of Attorney has been subscribed by an authorized officer or official of the Companies and the corporate seals of the Companies have been affixed thereto this 23rd day of August, 2018



The Ohio Casualty Insurance Company  
Liberty Mutual Insurance Company  
West American Insurance Company

By: David M. Carey  
David M. Carey, Assistant Secretary

STATE OF PENNSYLVANIA ss  
COUNTY OF MONTGOMERY

On this 23rd day of August, 2018, before me personally appeared David M. Carey, who acknowledged himself to be the Assistant Secretary of Liberty Mutual Insurance Company, The Ohio Casualty Company, and West American Insurance Company, and that he, as such, being authorized so to do, execute the foregoing instrument for the purposes therein contained by signing on behalf of the corporations by himself as a duly authorized officer.

IN WITNESS WHEREOF, I have hereunto subscribed my name and affixed my notarial seal at King of Prussia, Pennsylvania, on the day and year first above written.



COMMONWEALTH OF PENNSYLVANIA  
Notarial Seal  
Teresa Pastella, Notary Public  
Upper Merion Twp., Montgomery County  
My Commission Expires March 28, 2021  
Member, Pennsylvania Association of Notaries

By: Teresa Pastella  
Teresa Pastella, Notary Public

This Power of Attorney is made and executed pursuant to and by authority of the following By-laws and Authorizations of The Ohio Casualty Insurance Company, Liberty Mutual Insurance Company, and West American Insurance Company which resolutions are now in full force and effect reading as follows:

**ARTICLE IV - OFFICERS - Section 12. Power of Attorney.** Any officer or other official of the Corporation authorized for that purpose in writing by the Chairman or the President, and subject to such limitation as the Chairman or the President may prescribe, shall appoint such attorneys-in-fact, as may be necessary to act in behalf of the Corporation to make, execute, seal, acknowledge and deliver as surety any and all undertakings, bonds, recognizances and other surety obligations. Such attorneys-in-fact, subject to the limitations set forth in their respective powers of attorney, shall have full power to bind the Corporation by their signature and execution of any such instruments and to attach thereto the seal of the Corporation. When so executed, such instruments shall be as binding as if signed by the President and attested to by the Secretary. Any power or authority granted to any representative or attorney-in-fact under the provisions of this article may be revoked at any time by the Board, the Chairman, the President or by the officer or officers granting such power or authority.

**ARTICLE XIII - Execution of Contracts - SECTION 5. Surety Bonds and Undertakings.** Any officer of the Company authorized for that purpose in writing by the chairman or the president, and subject to such limitations as the chairman or the president may prescribe, shall appoint such attorneys-in-fact, as may be necessary to act in behalf of the Company to make, execute, seal, acknowledge and deliver as surety any and all undertakings, bonds, recognizances and other surety obligations. Such attorneys-in-fact subject to the limitations set forth in their respective powers of attorney, shall have full power to bind the Company by their signature and execution of any such instruments and to attach thereto the seal of the Company. When so executed such instruments shall be as binding as if signed by the president and attested by the secretary.

**Certificate of Designation -** The President of the Company, acting pursuant to the Bylaws of the Company, authorizes David M. Carey, Assistant Secretary to appoint such attorneys-in-fact as may be necessary to act on behalf of the Company to make, execute, seal, acknowledge and deliver as surety any and all undertakings, bonds, recognizances and other surety obligations.

**Authorization -** By unanimous consent of the Company's Board of Directors, the Company consents that facsimile or mechanically reproduced signature of any assistant secretary of the Company, wherever appearing upon a certified copy of any power of attorney issued by the Company in connection with surety bonds, shall be valid and binding upon the Company with the same force and effect as though manually affixed.

I, Renee C. Llewellyn, the undersigned, Assistant Secretary, The Ohio Casualty Insurance Company, Liberty Mutual Insurance Company, and West American Insurance Company do hereby certify that the original power of attorney of which the foregoing is a full, true and correct copy of the Power of Attorney executed by said Companies, is in full force and effect and has not been revoked.

IN TESTIMONY WHEREOF, I have hereunto set my hand and affixed the seals of said Companies this 30th day of January, 20 20



By: Renee C. Llewellyn  
Renee C. Llewellyn, Assistant Secretary

Not valid for mortgage, note, loan, letter of credit, currency rate, interest rate or residual value guarantee.

To confirm the validity of this Power of Attorney call 1-610-832-8240 between 9:00 am and 4:30 pm EST on any business day.



# CERTIFICATE OF LIABILITY INSURANCE

DATE (MM/DD/YYYY)  
1/30/2020

**THIS CERTIFICATE IS ISSUED AS A MATTER OF INFORMATION ONLY AND CONFERS NO RIGHTS UPON THE CERTIFICATE HOLDER. THIS CERTIFICATE DOES NOT AFFIRMATIVELY OR NEGATIVELY AMEND, EXTEND OR ALTER THE COVERAGE AFFORDED BY THE POLICIES BELOW. THIS CERTIFICATE OF INSURANCE DOES NOT CONSTITUTE A CONTRACT BETWEEN THE ISSUING INSURER(S), AUTHORIZED REPRESENTATIVE OR PRODUCER, AND THE CERTIFICATE HOLDER.**

**IMPORTANT: If the certificate holder is an ADDITIONAL INSURED, the policy(ies) must have ADDITIONAL INSURED provisions or be endorsed. If SUBROGATION IS WAIVED, subject to the terms and conditions of the policy, certain policies may require an endorsement. A statement on this certificate does not confer rights to the certificate holder in lieu of such endorsement(s).**

<b>PRODUCER</b> Peoples Insurance Agency, LLC 101 Fifth Avenue Huntington WV 25724		<b>CONTACT NAME:</b> Tom Bottoms <b>PHONE (A/C, No, Ext):</b> 304-528-2478 <b>FAX (A/C, No):</b> 304-522-6563 <b>E-MAIL ADDRESS:</b> Thomas.Bottoms@pebo.com	
		<b>INSURER(S) AFFORDING COVERAGE</b>	
		<b>INSURER A:</b> Great American E & S Ins. Co.	<b>NAIC #</b> 37532
		<b>INSURER B:</b> National Fire Ins. Of Hartford	20478
		<b>INSURER C:</b> Continental Insurance Co.	35289
		<b>INSURER D:</b>	
		<b>INSURER E:</b>	
		<b>INSURER F:</b>	

**COVERAGES** **CERTIFICATE NUMBER: 670368719** **REVISION NUMBER:**

THIS IS TO CERTIFY THAT THE POLICIES OF INSURANCE LISTED BELOW HAVE BEEN ISSUED TO THE INSURED NAMED ABOVE FOR THE POLICY PERIOD INDICATED. NOTWITHSTANDING ANY REQUIREMENT, TERM OR CONDITION OF ANY CONTRACT OR OTHER DOCUMENT WITH RESPECT TO WHICH THIS CERTIFICATE MAY BE ISSUED OR MAY PERTAIN, THE INSURANCE AFFORDED BY THE POLICIES DESCRIBED HEREIN IS SUBJECT TO ALL THE TERMS, EXCLUSIONS AND CONDITIONS OF SUCH POLICIES. LIMITS SHOWN MAY HAVE BEEN REDUCED BY PAID CLAIMS.

INSR LTR	TYPE OF INSURANCE	ADDL SUBR INSD   WVD	POLICY NUMBER	POLICY EFF (MM/DD/YYYY)	POLICY EXP (MM/DD/YYYY)	LIMITS
B A	<input checked="" type="checkbox"/> COMMERCIAL GENERAL LIABILITY <input type="checkbox"/> CLAIMS-MADE <input checked="" type="checkbox"/> OCCUR Completed Ops GEN'L AGGREGATE LIMIT APPLIES PER: <input type="checkbox"/> POLICY <input checked="" type="checkbox"/> PRO-JECT <input type="checkbox"/> LOC OTHER:		6076010702 PL384243803	5/15/2019 5/15/2019	5/15/2020 5/15/2020	EACH OCCURRENCE \$ 2,000,000 DAMAGE TO RENTED PREMISES (Ea occurrence) \$ 500,000 MED EXP (Any one person) \$ 15,000 PERSONAL & ADV INJURY \$ 2,000,000 GENERAL AGGREGATE \$ 2,000,000 PRODUCTS - COM/PO/ AGG \$ 2,000,000 Emp Ben. \$ 1,000,000
B	<input checked="" type="checkbox"/> ANY AUTO <input checked="" type="checkbox"/> OWNED AUTOS ONLY <input checked="" type="checkbox"/> HIRED AUTOS ONLY <input type="checkbox"/> SCHEDULED AUTOS <input checked="" type="checkbox"/> NON-OWNED AUTOS ONLY		6076010747	5/15/2019	5/15/2020	COMBINED SINGLE LIMIT (Ea accident) \$ 1,000,000 BODILY INJURY (Per person) \$ BODILY INJURY (Per accident) \$ PROPERTY DAMAGE (Per accident) \$ \$
C	<input checked="" type="checkbox"/> UMBRELLA LIAB <input checked="" type="checkbox"/> OCCUR <input type="checkbox"/> EXCESS LIAB <input type="checkbox"/> CLAIMS-MADE DED <input checked="" type="checkbox"/> RETENTION \$ 10,000		6076010733	5/15/2019	5/15/2020	EACH OCCURRENCE \$ 5,000,000 AGGREGATE \$ 5,000,000 \$
C	WORKERS COMPENSATION AND EMPLOYERS' LIABILITY ANY PROPRIETOR/PARTNER/EXECUTIVE OFFICER/MEMBER EXCLUDED? (Mandatory in NH) If yes, describe under DESCRIPTION OF OPERATIONS below	Y/N N	6076010733	5/15/2019	5/15/2020	<input checked="" type="checkbox"/> PER STATUTE <input type="checkbox"/> OTHER E.L. EACH ACCIDENT \$ 1,000,000 E.L. DISEASE - EA EMPLOYEE \$ 1,000,000 E.L. DISEASE - POLICY LIMIT \$ 1,000,000
B B	Inst Floater Cargo Coverage		6076010702 6076010702	5/15/2019 5/15/2019	5/15/2020 5/15/2020	Installation Floater 100,000 Cargo 100,000

DESCRIPTION OF OPERATIONS / LOCATIONS / VEHICLES (ACORD 101, Additional Remarks Schedule, may be attached if more space is required)  
 Evidence of insurance. Workers compensation includes West Virginia broad form employers liability endorsement.

<b>CERTIFICATE HOLDER</b>  State of West Virginia Department of Administration Purchasing Division 2019 Washington St. E. Charleston WV 25305	<b>CANCELLATION</b>  SHOULD ANY OF THE ABOVE DESCRIBED POLICIES BE CANCELLED BEFORE THE EXPIRATION DATE THEREOF, NOTICE WILL BE DELIVERED IN ACCORDANCE WITH THE POLICY PROVISIONS.  AUTHORIZED REPRESENTATIVE 
---	--

WV-10  
Approved / Revised  
06/08/18

# State of West Virginia VENDOR PREFERENCE CERTIFICATE

Certification and application is hereby made for Preference in accordance with *West Virginia Code*, §5A-3-37. (Does not apply to construction contracts). *West Virginia Code*, §5A-3-37, provides an opportunity for qualifying vendors to request (at the time of bid) preference for their residency status. Such preference is an evaluation method only and will be applied only to the cost bid in accordance with the *West Virginia Code*. This certificate for application is to be used to request such preference. The Purchasing Division will make the determination of the Vendor Preference, if applicable.

1.  Application is made for 2.5% vendor preference for the reason checked:  
Bidder is an individual resident vendor and has resided continuously in West Virginia, or bidder is a partnership, association or corporation resident vendor and has maintained its headquarters or principal place of business continuously in West Virginia, for four (4) years immediately preceding the date of this certification; or,
  - Bidder is a resident vendor partnership, association, or corporation with at least eighty percent of ownership interest of bidder held by another entity that meets the applicable four year residency requirement; or,
  - Bidder is a nonresident vendor which has an affiliate or subsidiary which employs a minimum of one hundred state residents and which has maintained its headquarters or principal place of business within West Virginia continuously for the four (4) years immediately preceding the date of this certification; or,
2.  Application is made for 2.5% vendor preference for the reason checked:  
Bidder is a resident vendor who certifies that, during the life of the contract, on average at least 75% of the employees working on the project being bid are residents of West Virginia who have resided in the state continuously for the two years immediately preceding submission of this bid; or,
3.  Application is made for 2.5% vendor preference for the reason checked:  
Bidder is a nonresident vendor that employs a minimum of one hundred state residents, or a nonresident vendor which has an affiliate or subsidiary which maintains its headquarters or principal place of business within West Virginia and employs a minimum of one hundred state residents, and for purposes of producing or distributing the commodities or completing the project which is the subject of the bidder's bid and continuously over the entire term of the project, on average at least seventy-five percent of the bidder's employees or the bidder's affiliate's or subsidiary's employees are residents of West Virginia who have resided in the state continuously for the two immediately preceding years and the vendor's bid; or,
4.  Application is made for 5% vendor preference for the reason checked:  
Bidder meets either the requirement of both subdivisions (1) and (2) or subdivision (1) and (3) as stated above; or,
5.  Application is made for 3.5% vendor preference who is a veteran for the reason checked:  
Bidder is an individual resident vendor who is a veteran of the United States armed forces, the reserves or the National Guard and has resided in West Virginia continuously for the four years immediately preceding the date on which the bid is submitted; or,
6.  Application is made for 3.5% vendor preference who is a veteran for the reason checked:  
Bidder is a resident vendor who is a veteran of the United States armed forces, the reserves or the National Guard, if, for purposes of producing or distributing the commodities or completing the project which is the subject of the vendor's bid and continuously over the entire term of the project, on average at least seventy-five percent of the vendor's employees are residents of West Virginia who have resided in the state continuously for the two immediately preceding years.
7.  Application is made for preference as a non-resident small, women- and minority-owned business, in accordance with *West Virginia Code* §5A-3-59 and *West Virginia Code of State Rules*.  
Bidder has been or expects to be approved prior to contract award by the Purchasing Division as a certified small, women- and minority-owned business.
8.  Application is made for reciprocal preference.  
Bidder is a West Virginia resident and is requesting reciprocal preference to the extent that it applies.

Bidder understands if the Secretary of Revenue determines that a Bidder receiving preference has failed to continue to meet the requirements for such preference, the Secretary may order the Director of Purchasing to: (a) rescind the contract or purchase order, or (b) assess a penalty against such Bidder in an amount not to exceed 5% of the bid amount and that such penalty will be paid to the contracting agency or deducted from any unpaid balance on the contract or purchase order.

By submission of this certificate, Bidder agrees to disclose any reasonably requested information to the Purchasing Division and authorizes the Department of Revenue to disclose to the Director of Purchasing appropriate information verifying that Bidder has paid the required business taxes, provided that such information does not contain the amounts of taxes paid nor any other information deemed by the Tax Commissioner to be confidential.

Bidder hereby certifies that this certificate is true and accurate in all respects; and that if a contract is issued to Bidder and if anything contained within this certificate changes during the term of the contract, Bidder will notify the Purchasing Division in writing immediately.

Bidder: SERVICE PUMP & SUPPLY Signed: [Signature]  
 Date: November 19, 2019 Title: PRESIDENT

\*Check any combination of preference consideration(s) indicated above, which you are entitled to receive

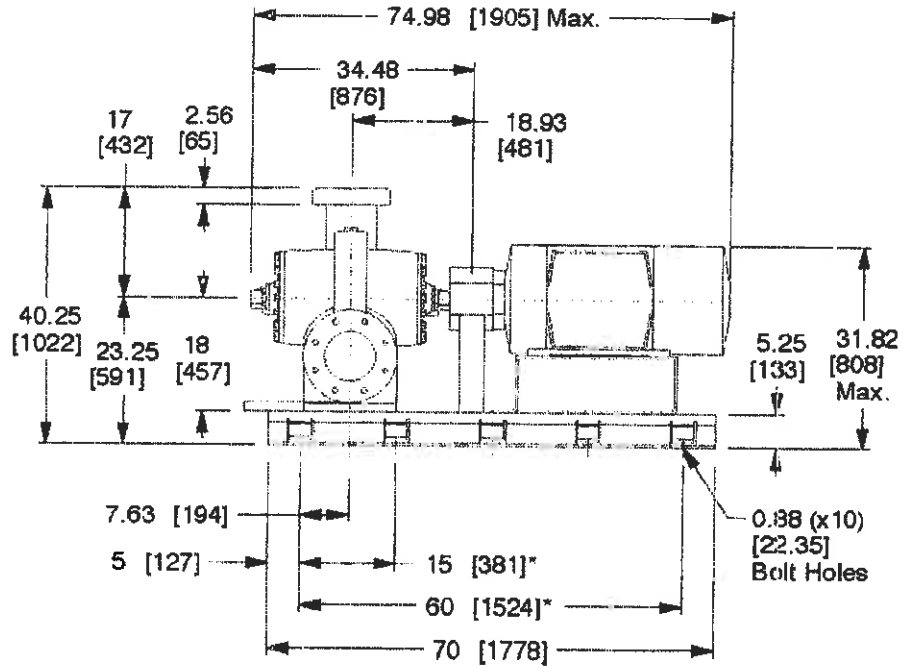
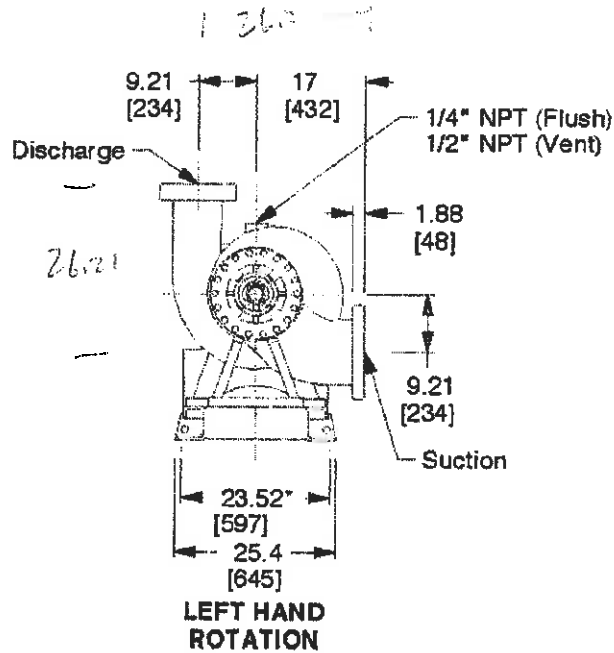
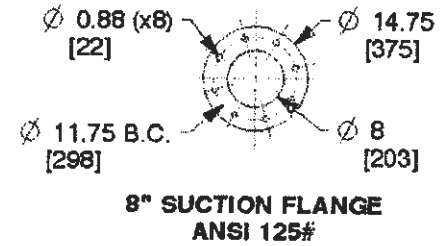
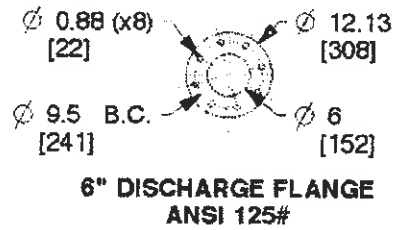
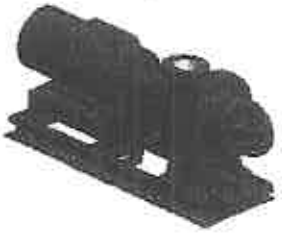

\* Dist. Between Bolt Holes



**Bell & Gossett**  
a xylem brand

8200 N. Austin Ave.  
Morton Grove, IL 60053, USA

This drawing and the information depicted therein is the property of Xylem. Copies are issued in strict confidence and shall not be reproduced or copied, or used as the basis for the manufacture or sale of products without prior written permission of Xylem.

Dimensions are subject to change  
Not to be used for construction unless certified

**VSCS-6X8X13P5A-324TTS-SPL**

Series vscs Double Suction Split Case Pump  
Motor Frame: 324T/TS | Coupler: Spacer Coupler | Hand of Rotation: Left Hand  
Removal Clearance: 24 | Flange: ANSI 125#

Dimensions : N (mm)      Scale : N.T.S.      Submittal # : B-854.2D



# Submittal

Job/Project: 19-14286 VSC Replacement		Representative: Blackmore and Glunt, Inc.	
ESP-Systemwize: WIZE-7441F4	Created On: 11/18/2019	Phone:	
Location/Tag: P-6		Email:	
Engineer:		Submitted By: Eric Meyer	Date: 11/18/2019
Contractor:		Approved By:	Date:

## Double Suction Split Case Pump

Series: VSX-VSCS

Model: 6x8x13.5A

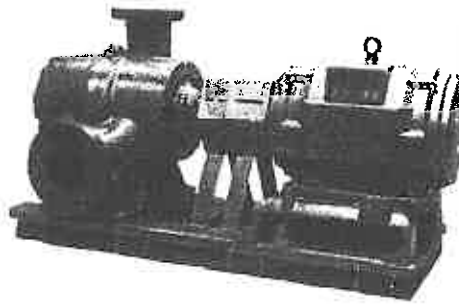

### Features & Design

- Space saving footprint
- Multiple suction and discharge flange orientations
- Maintenance-free bearings
- Alignment-friendly coupling

The Bell & Gossett Series VSX-VSCS has maintenance-free Bearings, a one-piece unitized seal, groutless base plate, and alignment-friendly coupling

### Pump Selection Summary

Duty Point Flow	1440.0 US gpm
Duty Point Head	44.0 ft
Control Head	0.0 ft
Duty Point Pump Efficiency	80.1 %
Part Load Efficiency Value (PLEV)	0.0 %
Impeller Diameter	11.625 in
Motor Power	25 hp
Duty Point Power	20.1 bhp
Motor Speed	1200 rpm
RPM @ Duty Point	1180 rpm
NPSHr	5.94 ft
Minimum Shutoff Head	62 ft
Minimum Flow at RPM	284 US gpm
Flow @ BEP	1237 US gpm
Fluid Temperature	68 °F
Fluid Type	Water
Weight (approx. - consult rep for exact)	2298 lbs
Pump Floor Space Calculation	13.75 ft <sup>2</sup>

## Performance Curve



**VSX-VSCS**  
6x8x13.5A  
1180 RPM

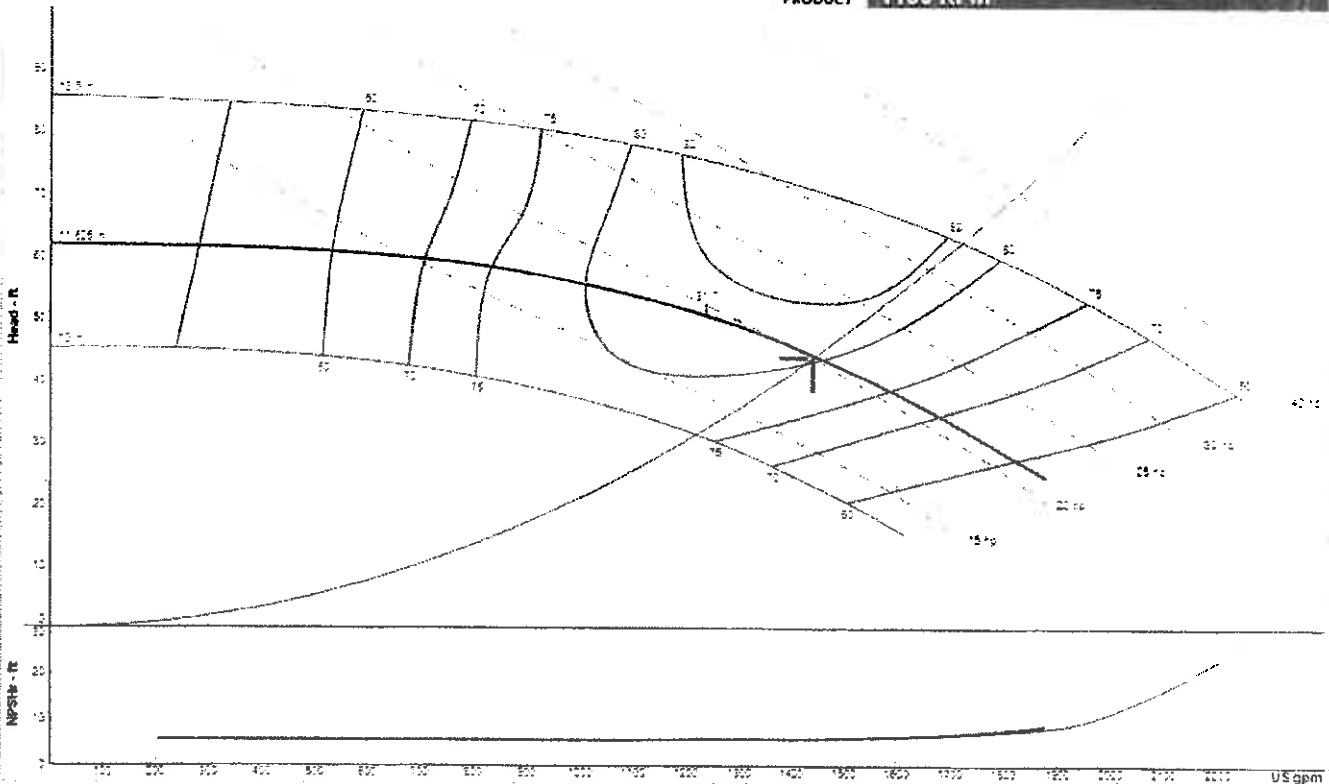

Performance curve meets 14.6 / ISO 9906 acceptance criteria

### Materials Of Construction

#### Pump Information\Construction

Pump Series	VSX-VSCS
Pump Size	6 x 8 x 13-1/2A
Seal Type	Standard Seal
Seal Material	Unitized EPR-Carbon/SiC
Material of Construction	Bronze Fitted
Impeller Diameter	11.625 inches
Sleeve Material	Standard
Left-Hand Rotation	

#### Motor Details

Motor Power	25
Motor Speed	1200
Frequency	60
Phase	3
Voltage	208-230/460
Frame	324T
Enclosure	ODP
Motor Manufacturer	BG Choice
Motor Status	
Motor Comments	Nema Premium Efficient

#### Selected Options

Selected Option 1	Woods Duraflex Spacer
-------------------	-----------------------



# AURORA ACCESSORIES

## SUCTION DIFFUSER - MODEL SD

Section **1030** Page **201**

Dated **DECEMBER 2010**

Supersedes May 2010

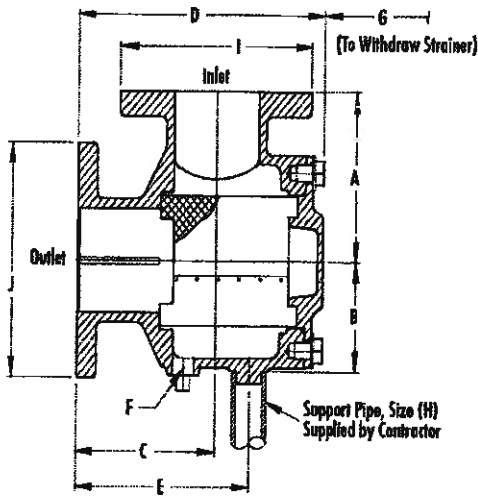

### Materials of Construction

Body	Cast Iron
Strainer	Stainless Steel, 0.125" (3mm) Perf.
Start-Up Strainer (remove after 1 week)	Fine Mesh Galvanized Steel
Diffuser Vanes	Cast Iron
Inlet Gauge Tapping	1/4" NPT - Plugged

### Maximum Operating Conditions

Maximum Working Pressure	175 psig (12 bars)
Maximum Operating Temperature	300°F (150°C)

Companion flanges not included.

MODEL	Connection Size		Strainer Free Sq. In. (Sq. cm.)	DIMENSIONS in inches (mm)										Weight lbs. (kg)
	System	Pump		A	B	C	D	E	F	G	H	I	J	
SD0215	2 (51)	1.5 (38)	34 (222)	4.50 (114)	3.07 (78)	8.63 (219)	12.63 (321)	9.84 (250)	0.50 (13)	4.75 (121)	1.00 (25)	6.00 (152)	5.00 (127)	31 (14.1)
SD0202	2 (51)	2 (51)	34 (222)	4.50 (114)	3.07 (78)	4.50 (114)	8.50 (216)	5.71 (145)	0.50 (13)	4.75 (121)	1.00 (25)	6.00 (152)	6.00 (152)	26 (11.8)
SD2502	2.5 (64)	2 (51)	34 (222)	5.00 (127)	3.07 (78)	4.50 (114)	8.50 (216)	5.71 (145)	0.50 (13)	4.75 (121)	1.00 (25)	7.00 (178)	6.00 (152)	29 (13.2)
SD0302	3 (76)	2 (51)	34 (222)	5.50 (140)	3.07 (78)	4.50 (114)	8.50 (216)	5.71 (145)	0.50 (13)	4.75 (121)	1.00 (25)	7.50 (191)	6.00 (152)	31 (14.1)
SD2525	2.5 (64)	2.5 (64)	34 (222)	4.90 (124)	3.07 (78)	4.90 (124)	7.50 (191)	5.86 (149)	0.50 (13)	4.75 (121)	1.00 (25)	7.12 (181)	7.12 (181)	34 (15.4)
SD0325	3 (76)	2.5 (64)	34 (222)	5.50 (140)	3.07 (78)	4.90 (124)	7.50 (191)	5.86 (149)	0.50 (13)	4.75 (121)	1.00 (25)	7.50 (191)	7.12 (181)	35 (15.9)
SD0303	3 (76)	3 (76)	44 (282)	5.40 (137)	3.63 (92)	5.40 (137)	9.88 (251)	7.00 (178)	0.75 (19)	5.50 (140)	1.00 (25)	7.81 (198)	7.81 (198)	45 (20.4)
SD0403	4 (102)	3 (76)	44 (282)	6.50 (165)	3.63 (92)	5.90 (150)	10.38 (264)	7.50 (191)	0.75 (19)	5.50 (140)	1.00 (25)	9.00 (229)	7.81 (198)	53 (24.0)
SD0404	4 (102)	4 (102)	79 (511)	6.50 (165)	4.19 (106)	6.50 (165)	11.75 (298)	8.13 (206)	0.75 (19)	7.00 (178)	1.25 (32)	9.00 (229)	9.00 (229)	72 (32.7)
SD0504	5 (127)	4 (102)	79 (511)	7.44 (189)	4.19 (106)	6.50 (165)	11.75 (298)	8.13 (206)	0.75 (19)	7.00 (178)	1.25 (32)	10.00 (254)	9.00 (229)	79 (35.8)
SD0604	6 (152)	4 (102)	79 (511)	8.03 (204)	4.19 (106)	7.50 (191)	12.75 (324)	9.13 (232)	0.75 (19)	7.00 (178)	1.25 (32)	11.00 (279)	9.00 (229)	87 (39.5)
SD0505	5 (127)	5 (127)	111 (719)	7.47 (190)	4.81 (122)	7.47 (190)	13.50 (343)	9.47 (241)	1.00 (25)	8.00 (203)	1.25 (32)	10.00 (254)	10.00 (254)	99 (44.9)
SD0605	6 (152)	5 (127)	111 (719)	8.00 (203)	4.81 (122)	7.47 (190)	13.50 (343)	9.47 (241)	1.00 (25)	8.00 (203)	1.25 (32)	11.15 (283)	10.00 (254)	103 (46.7)
SD0606	6 (152)	6 (152)	120 (775)	8.00 (203)	5.71 (145)	8.00 (203)	14.75 (375)	10.19 (259)	1.00 (25)	9.25 (235)	2.00 (51)	11.15 (283)	11.15 (283)	141 (63.9)
SD0806	8 (203)	6 (152)	120 (775)	9.00 (229)	5.71 (145)	10.00 (254)	16.75 (425)	12.19 (310)	1.00 (25)	9.25 (235)	2.00 (51)	13.50 (343)	11.15 (283)	180 (81.6)
SD0808	8 (203)	8 (203)	273 (1760)	8.93 (227)	7.00 (178)	10.28 (261)	18.75 (476)	13.42 (341)	1.00 (25)	12.25 (311)	2.00 (51)	13.50 (343)	13.50 (343)	213 (96.6)
SD1008	10 (254)	8 (203)	273 (1760)	10.93 (278)	7.00 (178)	12.78 (325)	21.25 (540)	15.92 (404)	1.00 (25)	12.25 (311)	2.00 (51)	16.00 (406)	13.50 (343)	246 (111.6)
SD1010	10 (254)	10 (254)	538 (3474)	11.43 (290)	8.13 (207)	12.72 (323)	23.25 (591)	16.85 (428)	1.00 (25)	15.00 (381)	2.00 (51)	16.00 (406)	16.00 (406)	349 (158.3)
SD1210	12 (305)	10 (254)	538 (3474)	13.00 (330)	8.13 (207)	15.72 (399)	26.25 (667)	19.85 (504)	1.00 (25)	15.00 (381)	2.00 (51)	19.00 (483)	16.00 (406)	390 (176.9)
SD1212	12 (305)	12 (305)	753 (4861)	15.30 (389)	10.76 (273)	14.18 (360)	27.50 (699)	20.45 (519)	1.00 (25)	19.00 (483)	2.00 (51)	19.00 (483)	19.00 (483)	641 (290.7)
SD1412	14 (356)	12 (305)	753 (4861)	16.00 (406)	10.76 (273)	14.18 (360)	27.50 (699)	20.45 (519)	1.00 (25)	19.00 (483)	2.00 (51)	21.00 (533)	19.00 (483)	637 (288.9)
SD1414	14 (356)	14 (356)	997 (6433)	14.00 (356)	11.00 (279)	14.00 (356)	28.00 (711)	17.50 (445)	2.00 (51)	21.00 (533)	2.00 (51)	21.00 (533)	21.00 (533)	710 (322.0)
SD1614	16 (406)	14 (356)	997 (6433)	14.00 (356)	12.00 (305)	15.00 (381)	27.88 (708)	17.50 (445)	2.00 (51)	21.00 (533)	2.00 (51)	23.50 (597)	21.00 (533)	750 (340.1)

**NOTES:**

1. Dimensions and weights are for reference only.
2. Please allow +/- 0.25" (6mm) dimensional tolerance.
3. Contact the factory for certified dimension prints.



**AURORA ACCESSORIES**  
**SUCTION DIFFUSER – MODEL SD**

Section **1030** Page **203**

Dated **FEBRUARY 2012**

Supersedes Section 1030 Page 203  
 Dated December 2010

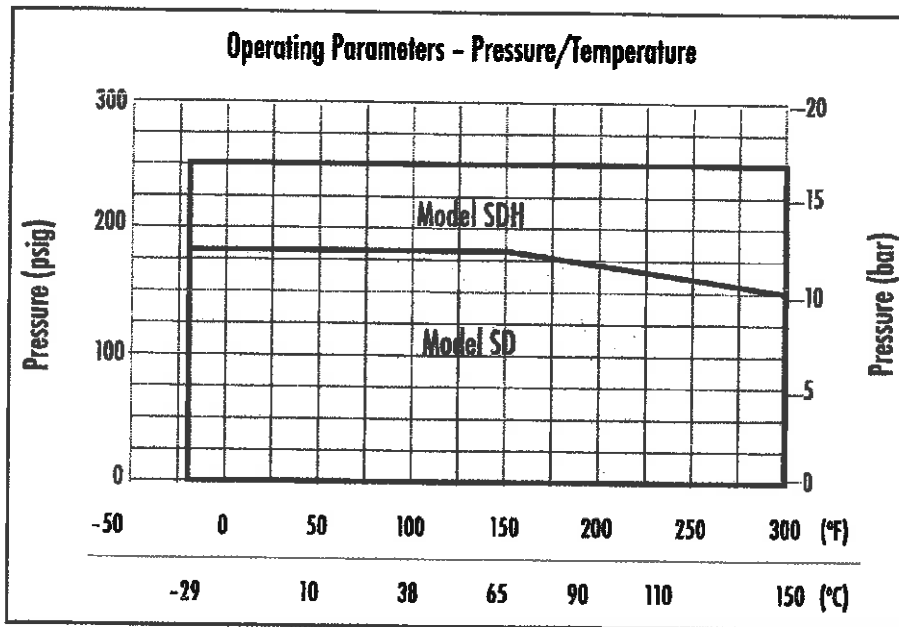

MODEL	Velocity in Feet Per Second (m/s)							
	f/s (m/s)	3 (0.91)	4 (1.22)	5 (1.52)	8 (1.83)	8 (2.44)	10 (3.05)	12 (3.66)
Pressure Drop in Feet (m) of Water @ Flow in US gpm (l/s)								
SD0215	ft (m) @ Us gpm(l/s)	0.05 (0.02) 19 (1.2)	0.08 (0.02) 25 (1.6)	0.13 (0.04) 32 (2.0)	0.19 (0.06) 38 (2.4)	0.35 (0.11) 52 (3.3)	0.52 (0.16) 63 (4.0)	0.77 (0.23) 77 (4.9)
SD0202 SD2502* SD0302*	ft (m) @ Us gpm (l/s)	0.11 (0.03) 32 (2.0)	0.20 (0.06) 43 (2.7)	0.32 (0.10) 54 (3.4)	0.43 (0.13) 64 (4.0)	0.80 (0.25) 86 (5.4)	1.28 (0.40) 108 (6.8)	1.72 (0.54) 128 (8.1)
SD2525 SD0325*	ft (m) @ Us gpm(l/s)	0.18 (0.05) 45 (2.8)	0.32 (0.10) 50 (3.2)	0.50 (0.15) 75 (4.7)	0.72 (0.22) 90 (5.7)	1.28 (0.39) 120 (7.6)	2.00 (0.61) 150 (9.5)	2.88 (0.88) 180 (11.4)
SD0303 SD0403*	ft (m) @ Us gpm (l/s)	0.20 (0.06) 70 (4.4)	0.35 (0.11) 92 (5.8)	0.55 (0.17) 115 (7.3)	0.80 (0.24) 138 (8.7)	1.42 (0.43) 185 (11.7)	2.20 (0.67) 230 (14.5)	3.15 (0.96) 276 (17.4)
SD0404 SD0504* SD0604*	ft (m) @ Us gpm(l/s)	0.17 (0.05) 118 (7.4)	0.29 (0.09) 155 (9.8)	0.47 (0.14) 198 (12.5)	0.68 (0.21) 238 (15.0)	1.20 (0.37) 315 (19.9)	1.90 (0.58) 396 (25.0)	2.75 (0.84) 475 (30.0)
SD0505 SD0605*	ft (m) @ Us gpm (l/s)	0.23 (0.07) 187 (11.8)	0.41 (0.13) 250 (15.8)	0.67 (0.20) 315 (19.9)	0.95 (0.29) 375 (23.7)	1.70 (0.52) 500 (31.5)	2.65 (0.81) 625 (39.4)	3.80 (1.16) 750 (47.3)
SD0606 SD0806*	ft (m) @ Us gpm (l/s)	0.22 (0.07) 270 (17.0)	0.38 (0.12) 360 (22.7)	0.60 (0.18) 450 (28.4)	0.86 (0.26) 540 (34.1)	1.54 (0.47) 720 (45.4)	2.40 (0.73) 900 (56.8)	3.45 (1.05) 1080 (68.1)
SD0808 SD1008*	ft (m) @ Us gpm (l/s)	0.21 (0.06) 470 (29.7)	0.37 (0.11) 625 (39.4)	0.58 (0.18) 780 (49.2)	0.85 (0.26) 940 (59.3)	1.50 (0.46) 1250 (78.9)	2.30 (0.70) 1550 (97.8)	3.35 (1.02) 1870 (118.0)
SD1010 SD1210*	ft (m) @ Us gpm (l/s)	0.26 (0.08) 740 (46.7)	0.46 (0.14) 980 (61.8)	0.73 (0.22) 1230 (77.6)	1.03 (0.31) 1480 (93.4)	1.85 (0.56) 1960 (123.7)	2.92 (0.89) 2450 (154.6)	4.20 (1.28) 2940 (185.5)
SD1212 SD1412*	ft (m) @ Us gpm (l/s)	0.25 (0.08) 1080 (68.1)	0.44 (0.13) 1400 (88.3)	0.72 (0.22) 1750 (110.4)	1.02 (0.31) 2100 (132.5)	1.81 (0.55) 2800 (176.7)	2.80 (0.85) 3500 (220.8)	4.00 (1.22) 4200 (265.0)
SD1414 SD1614*	ft (m) @ Us gpm (l/s)	0.28 (0.09) 1440 (90.9)	0.58 (0.18) 1920 (121.1)	0.92 (0.28) 2400 (151.4)	1.23 (0.38) 2880 (181.7)	2.13 (0.65) 3840 (242.3)	3.50 (1.07) 4800 (302.8)	5.30 (1.62) 5760 (363.4)

\*Flange size does not apply to pipe size entrance into suction diffuser.

