



Purchasing Division
 2019 Washington Street East
 Post Office Box 50130
 Charleston, WV 25305-0130

State of West Virginia
 Request for Quotation
 36 - Vehicles

Proc Folder: 558049

Doc Description: 2018 or Newer, Class 8 Extended Day Cab Tandem Tractor

Proc Type: Central Purchase Order

Date Issued	Solicitation Closes	Solicitation No	Version
2019-03-22	2019-04-05 13:30:00	CRFQ 0214 SUR1900000005	1

BID RECEIVING LOCATION

BID CLERK
 DEPARTMENT OF ADMINISTRATION
 PURCHASING DIVISION
 2019 WASHINGTON ST E
 CHARLESTON
 US

WV 25305

VENDOR

Vendor Name, Address and Telephone Number:

Martins Peterbilt
 715 Orchard Park Rd. Hurricane Wv 25526
 (304) 562-7999

RECEIVED

2019 APR -5 PM 1:07

WV PURCHASING
 DIVISION

FOR INFORMATION CONTACT THE BUYER

Melissa Petrey
 (304) 558-0094
 melissa.k.petrey@wv.gov

Signature X

FEIN #

32-0029702

DATE

04/05/19

All offers subject to all terms and conditions contained in this solicitation

Central Request for Quotation

The West Virginia Purchasing Division is soliciting bids on behalf of the West Virginia State Agency for Surplus Property to establish a Contract for the One-Time Purchase of a 2018 or newer, Class 8 Extended Day Cab Tandem Tractor per the bid requirements, specifications, terms and conditions attached to this solicitation.

OFFICE TO	OFFICE
ADMINISTRATIVE SERVICES MANAGER DEPARTMENT OF ADMINISTRATION SURPLUS PROPERTY 2700 CHARLES AVE DUNBAR WV25064-2236 US	ADMINISTRATIVE SERVICES MANAGER DEPARTMENT OF ADMINISTRATION SURPLUS PROPERTY 2700 CHARLES AVE DUNBAR WV 25064 US

Line	Comm Ln Desc	Qty	Unit Issue	Unit Price	Total Price
1	2018 or Newer Class 8 Tandem Axle Truck Tractor	1.00000	EA		

Comm Code	Manufacturer	Specification	Model #
25102100	Peterbilt	Extended Day-cab Tractor	389

Extended Description :
 2018 or Newer, Class 8 Extended Day Cab Tandem Tractor per specifications

INSTRUCTIONS TO VENDORS SUBMITTING BIDS

1. REVIEW DOCUMENTS THOROUGHLY: The attached documents contain a solicitation for bids. Please read these instructions and all documents attached in their entirety. These instructions provide critical information about requirements that if overlooked could lead to disqualification of a Vendor's bid. All bids must be submitted in accordance with the provisions contained in these instructions and the Solicitation. Failure to do so may result in disqualification of Vendor's bid.

2. MANDATORY TERMS: The Solicitation may contain mandatory provisions identified by the use of the words "must," "will," and "shall." Failure to comply with a mandatory term in the Solicitation will result in bid disqualification.

3. PREBID MEETING: The item identified below shall apply to this Solicitation.

A pre-bid meeting will not be held prior to bid opening

A NON-MANDATORY PRE-BID meeting will be held at the following place and time:

A MANDATORY PRE-BID meeting will be held at the following place and time:

All Vendors submitting a bid must attend the mandatory pre-bid meeting. Failure to attend the mandatory pre-bid meeting shall result in disqualification of the Vendor's bid. No one person attending the pre-bid meeting may represent more than one Vendor.

An attendance sheet provided at the pre-bid meeting shall serve as the official document verifying attendance. The State will not accept any other form of proof or documentation to verify attendance. Any person attending the pre-bid meeting on behalf of a Vendor must list on the attendance sheet his or her name and the name of the Vendor he or she is representing.

Additionally, the person attending the pre-bid meeting should include the Vendor's E-Mail address, phone number, and Fax number on the attendance sheet. It is the Vendor's responsibility to locate the attendance sheet and provide the required information. Failure to complete the attendance sheet as required may result in disqualification of Vendor's bid.

All Vendors should arrive prior to the starting time for the pre-bid. Vendors who arrive after the starting time but prior to the end of the pre-bid will be permitted to sign in, but are charged with knowing all matters discussed at the pre-bid.

Questions submitted at least five business days prior to a scheduled pre-bid will be discussed at the pre-bid meeting if possible. Any discussions or answers to questions at the pre-bid meeting are preliminary in nature and are non-binding. Official and binding answers to questions will be published in a written addendum to the Solicitation prior to bid opening.

4. VENDOR QUESTION DEADLINE: Vendors may submit questions relating to this Solicitation to the Purchasing Division. Questions must be submitted in writing. All questions must be submitted on or before the date listed below and to the address listed below in order to be considered. A written response will be published in a Solicitation addendum if a response is possible and appropriate. Non-written discussions, conversations, or questions and answers regarding this Solicitation are preliminary in nature and are nonbinding.

Submitted e-mails should have solicitation number in the subject line.

Question Submission Deadline: 03/27/2019 @ 3:00 P.M. EDT

Submit Questions to: Melissa Pettrey, Senior Buyer
2019 Washington Street, East
Charleston, WV 25305
Fax: (304) 558-4115 (Vendors should not use this fax number for bid submission)
Email: melissa.k.pettrey@wv.gov

5. VERBAL COMMUNICATION: Any verbal communication between the Vendor and any State personnel is not binding, including verbal communication at the mandatory pre-bid conference. Only information issued in writing and added to the Solicitation by an official written addendum by the Purchasing Division is binding.

6. BID SUBMISSION: All bids must be submitted electronically through wvOASIS or signed and delivered by the Vendor to the Purchasing Division at the address listed below on or before the date and time of the bid opening. Any bid received by the Purchasing Division staff is considered to be in the possession of the Purchasing Division and will not be returned for any reason. The Purchasing Division will not accept bids, modification of bids, or addendum acknowledgment forms via e-mail. Acceptable delivery methods include electronic submission via wvOASIS, hand delivery, delivery by courier, or facsimile.

The bid delivery address is:
Department of Administration, Purchasing Division
2019 Washington Street East
Charleston, WV 25305-0130

A bid that is not submitted electronically through wvOASIS should contain the information listed below on the face of the envelope or the bid may be rejected by the Purchasing Division.:

SEALED BID:

BUYER: Melissa Pettrey, Senior Buyer
SOLICITATION NO.: CRFQ SUR1900000005
BID OPENING DATE: 04/05/2019
BID OPENING TIME: 1:30 P.M
FAX NUMBER: 304-558-3970

The Purchasing Division may prohibit the submission of bids electronically through wvOASIS at its sole discretion. Such a prohibition will be contained and communicated in the wvOASIS system resulting in the Vendor's inability to submit bids through wvOASIS. Submission of a response to an Expression or Interest or Request for Proposal is not permitted in wvOASIS.

For Request For Proposal ("RFP") Responses Only: In the event that Vendor is responding to a request for proposal, the Vendor shall submit one original technical and one original cost proposal plus N/A convenience copies of each to the Purchasing Division at the address shown above. Additionally, the Vendor should identify the bid type as either a technical or cost proposal on the face of each bid envelope submitted in response to a request for proposal as follows:

BID TYPE: (This only applies to CRFP)

- Technical
 Cost

7. BID OPENING: Bids submitted in response to this Solicitation will be opened at the location identified below on the date and time listed below. Delivery of a bid after the bid opening date and time will result in bid disqualification. For purposes of this Solicitation, a bid is considered delivered when confirmation of delivery is provided by wvOASIS (in the case of electronic submission) or when the bid is time stamped by the official Purchasing Division time clock (in the case of hand delivery).

Bid Opening Date and Time: 04/05/2019 @ 1:30 P.M. EDT

Bid Opening Location: Department of Administration, Purchasing Division
2019 Washington Street East
Charleston, WV 25305-0130

8. ADDENDUM ACKNOWLEDGEMENT: Changes or revisions to this Solicitation will be made by an official written addendum issued by the Purchasing Division. Vendor should acknowledge receipt of all addenda issued with this Solicitation by completing an Addendum Acknowledgment Form, a copy of which is included herewith. Failure to acknowledge addenda may result in bid disqualification. The addendum acknowledgement should be submitted with the bid to expedite document processing.

9. BID FORMATTING: Vendor should type or electronically enter the information onto its bid to prevent errors in the evaluation. Failure to type or electronically enter the information may result in bid disqualification.

10. ALTERNATE MODEL OR BRAND: Unless the box below is checked, any model, brand, or specification listed in this Solicitation establishes the acceptable level of quality only and is not intended to reflect a preference for, or in any way favor, a particular brand or vendor. Vendors may bid alternates to a listed model or brand provided that the alternate is at least equal to the model or brand and complies with the required specifications. The equality of any alternate being bid shall be determined by the State at its sole discretion. Any Vendor bidding an alternate model or brand should clearly identify the alternate items in its bid and should include manufacturer's specifications, industry literature, and/or any other relevant documentation demonstrating the equality of the alternate items. Failure to provide information for alternate items may be grounds for rejection of a Vendor's bid.

This Solicitation is based upon a standardized commodity established under W. Va. Code § 5A-3-61. Vendors are expected to bid the standardized commodity identified. Failure to bid the standardized commodity will result in your firm's bid being rejected.

11. EXCEPTIONS AND CLARIFICATIONS: The Solicitation contains the specifications that shall form the basis of a contractual agreement. Vendor shall clearly mark any exceptions, clarifications, or other proposed modifications in its bid. Exceptions to, clarifications of, or modifications of a requirement or term and condition of the Solicitation may result in bid disqualification.

12. COMMUNICATION LIMITATIONS: In accordance with West Virginia Code of State Rules §148-1-6.6, communication with the State of West Virginia or any of its employees regarding this Solicitation during the solicitation, bid, evaluation or award periods, except through the Purchasing Division, is strictly prohibited without prior Purchasing Division approval. Purchasing Division approval for such communication is implied for all agency delegated and exempt purchases.

13. REGISTRATION: Prior to Contract award, the apparent successful Vendor must be properly registered with the West Virginia Purchasing Division and must have paid the \$125 fee, if applicable.

14. UNIT PRICE: Unit prices shall prevail in cases of a discrepancy in the Vendor's bid.

15. PREFERENCE: Vendor Preference may be requested in purchases of motor vehicles or construction and maintenance equipment and machinery used in highway and other infrastructure projects. Any request for preference must be submitted in writing with the bid, must specifically identify the preference requested with reference to the applicable subsection of West Virginia Code § 5A-3-37, and should include with the bid any information necessary to evaluate and confirm the applicability of the requested preference. A request form to help facilitate the request can be found at:
<http://www.state.wv.us/admin/purchase/vrc/Venpref.pdf>.

15A. RECIPROCAL PREFERENCE: The State of West Virginia applies a reciprocal preference to all solicitations for commodities and printing in accordance with W. Va. Code § 5A-3-37(b). In effect, non-resident vendors receiving a preference in their home states, will see that same preference granted to West Virginia resident vendors bidding against them in West Virginia. A request form to help facilitate the request can be found at:
<http://www.state.wv.us/admin/purchase/vrc/Venpref.pdf>.

16. SMALL, WOMEN-OWNED, OR MINORITY-OWNED BUSINESSES: For any solicitations publicly advertised for bid, in accordance with West Virginia Code §5A-3-37(a)(7) and W. Va. CSR § 148-22-9, any non-resident vendor certified as a small, women-owned, or minority-owned business under W. Va. CSR § 148-22-9 shall be provided the same preference made available to any resident vendor. Any non-resident small, women-owned, or minority-owned business must identify itself as such in writing, must submit that writing to the Purchasing Division with its bid, and must be properly certified under W. Va. CSR § 148-22-9 prior to contract award to receive the preferences made available to resident vendors. Preference for a non-resident small, women-owned, or minority owned business shall be applied in accordance with W. Va. CSR § 148-22-9.

17. WAIVER OF MINOR IRREGULARITIES: The Director reserves the right to waive minor irregularities in bids or specifications in accordance with West Virginia Code of State Rules § 148-1-4.6.

18. ELECTRONIC FILE ACCESS RESTRICTIONS: Vendor must ensure that its submission in wvOASIS can be accessed and viewed by the Purchasing Division staff immediately upon bid opening. The Purchasing Division will consider any file that cannot be immediately accessed and viewed at the time of the bid opening (such as, encrypted files, password protected files, or incompatible files) to be blank or incomplete as context requires, and are therefore unacceptable. A vendor will not be permitted to unencrypt files, remove password protections, or resubmit documents after bid opening to make a file viewable if those documents are required with the bid. A Vendor may be required to provide document passwords or remove access restrictions to allow the Purchasing Division to print or electronically save documents provided that those documents are viewable by the Purchasing Division prior to obtaining the password or removing the access restriction.

19. NON-RESPONSIBLE: The Purchasing Division Director reserves the right to reject the bid of any vendor as Non-Responsible in accordance with W. Va. Code of State Rules § 148-1-5.3, when the Director determines that the vendor submitting the bid does not have the capability to fully perform, or lacks the integrity and reliability to assure good-faith performance.”

20. ACCEPTANCE/REJECTION: The State may accept or reject any bid in whole, or in part in accordance with W. Va. Code of State Rules § 148-1-4.5. and § 148-1-6.4.b.”

21. YOUR SUBMISSION IS A PUBLIC DOCUMENT: Vendor’s entire response to the Solicitation and the resulting Contract are public documents. As public documents, they will be disclosed to the public following the bid/proposal opening or award of the contract, as required by the competitive bidding laws of West Virginia Code §§ 5A-3-1 et seq., 5-22-1 et seq., and 5G-1-1 et seq. and the Freedom of Information Act West Virginia Code §§ 29B-1-1 et seq.

DO NOT SUBMIT MATERIAL YOU CONSIDER TO BE CONFIDENTIAL, A TRADE SECRET, OR OTHERWISE NOT SUBJECT TO PUBLIC DISCLOSURE.

Submission of any bid, proposal, or other document to the Purchasing Division constitutes your explicit consent to the subsequent public disclosure of the bid, proposal, or document. The Purchasing Division will disclose any document labeled “confidential,” “proprietary,” “trade secret,” “private,” or labeled with any other claim against public disclosure of the documents, to include any “trade secrets” as defined by West Virginia Code § 47-22-1 et seq. All submissions are subject to public disclosure without notice.

22. INTERESTED PARTY DISCLOSURE: West Virginia Code § 6D-1-2 requires that the vendor submit to the Purchasing Division a disclosure of interested parties to the contract for all contracts with an actual or estimated value of at least \$1 Million. That disclosure must occur on the form prescribed and approved by the WV Ethics Commission prior to contract award. A copy of that form is included with this solicitation or can be obtained from the WV Ethics Commission. This requirement does not apply to publicly traded companies listed on a national or international stock exchange. A more detailed definition of interested parties can be obtained from the form referenced above.

23. WITH THE BID REQUIREMENTS: In instances where these specifications require documentation or other information with the bid, and a vendor fails to provide it with the bid, the Director of the Purchasing Division reserves the right to request those items after bid opening and prior to contract award pursuant to the authority to waive minor irregularities in bids or specifications under W. Va. CSR § 148-1-4.6. This authority does not apply to instances where state law mandates receipt with the bid.

GENERAL TERMS AND CONDITIONS:

- 1. CONTRACTUAL AGREEMENT:** Issuance of a Award Document signed by the Purchasing Division Director, or his designee, and approved as to form by the Attorney General's office constitutes acceptance of this Contract made by and between the State of West Virginia and the Vendor. Vendor's signature on its bid signifies Vendor's agreement to be bound by and accept the terms and conditions contained in this Contract.
- 2. DEFINITIONS:** As used in this Solicitation/Contract, the following terms shall have the meanings attributed to them below. Additional definitions may be found in the specifications included with this Solicitation/Contract.
 - 2.1. "Agency" or "Agencies"** means the agency, board, commission, or other entity of the State of West Virginia that is identified on the first page of the Solicitation or any other public entity seeking to procure goods or services under this Contract.
 - 2.2. "Bid" or "Proposal"** means the vendors submitted response to this solicitation.
 - 2.3. "Contract"** means the binding agreement that is entered into between the State and the Vendor to provide the goods or services requested in the Solicitation.
 - 2.4. "Director"** means the Director of the West Virginia Department of Administration, Purchasing Division.
 - 2.5. "Purchasing Division"** means the West Virginia Department of Administration, Purchasing Division.
 - 2.6. "Award Document"** means the document signed by the Agency and the Purchasing Division, and approved as to form by the Attorney General, that identifies the Vendor as the contract holder.
 - 2.7. "Solicitation"** means the official notice of an opportunity to supply the State with goods or services that is published by the Purchasing Division.
 - 2.8. "State"** means the State of West Virginia and/or any of its agencies, commissions, boards, etc. as context requires.
 - 2.9. "Vendor" or "Vendors"** means any entity submitting a bid in response to the Solicitation, the entity that has been selected as the lowest responsible bidder, or the entity that has been awarded the Contract as context requires.

3. CONTRACT TERM; RENEWAL; EXTENSION: The term of this Contract shall be determined in accordance with the category that has been identified as applicable to this Contract below:

Term Contract

Initial Contract Term: This Contract becomes effective on _____ and extends for a period of _____ year(s).

Renewal Term: This Contract may be renewed upon the mutual written consent of the Agency, and the Vendor, with approval of the Purchasing Division and the Attorney General's office (Attorney General approval is as to form only). Any request for renewal should be delivered to the Agency and then submitted to the Purchasing Division thirty (30) days prior to the expiration date of the initial contract term or appropriate renewal term. A Contract renewal shall be in accordance with the terms and conditions of the original contract. Unless otherwise specified below, renewal of this Contract is limited to _____ successive one (1) year periods or multiple renewal periods of less than one year, provided that the multiple renewal periods do not exceed the total number of months available in all renewal years combined. Automatic renewal of this Contract is prohibited. Renewals must be approved by the Vendor, Agency, Purchasing Division and Attorney General's office (Attorney General approval is as to form only)

Alternate Renewal Term – This contract may be renewed for _____ successive _____ year periods or shorter periods provided that they do not exceed the total number of months contained in all available renewals. Automatic renewal of this Contract is prohibited. Renewals must be approved by the Vendor, Agency, Purchasing Division and Attorney General's office (Attorney General approval is as to form only)

Delivery Order Limitations: In the event that this contract permits delivery orders, a delivery order may only be issued during the time this Contract is in effect. Any delivery order issued within one year of the expiration of this Contract shall be effective for one year from the date the delivery order is issued. No delivery order may be extended beyond one year after this Contract has expired.

Fixed Period Contract: This Contract becomes effective upon Vendor's receipt of the notice to proceed and must be completed within _____ days.

Fixed Period Contract with Renewals: This Contract becomes effective upon Vendor's receipt of the notice to proceed and part of the Contract more fully described in the attached specifications must be completed within _____ days. Upon completion of the work covered by the preceding sentence, the vendor agrees that maintenance, monitoring, or warranty services will be provided for _____ year(s) thereafter.

One Time Purchase: The term of this Contract shall run from the issuance of the Award Document until all of the goods contracted for have been delivered, but in no event will this Contract extend for more than one fiscal year.

Other: See attached.

4. NOTICE TO PROCEED: Vendor shall begin performance of this Contract immediately upon receiving notice to proceed unless otherwise instructed by the Agency. Unless otherwise specified, the fully executed Award Document will be considered notice to proceed.

5. QUANTITIES: The quantities required under this Contract shall be determined in accordance with the category that has been identified as applicable to this Contract below.

Open End Contract: Quantities listed in this Solicitation are approximations only, based on estimates supplied by the Agency. It is understood and agreed that the Contract shall cover the quantities actually ordered for delivery during the term of the Contract, whether more or less than the quantities shown.

Service: The scope of the service to be provided will be more clearly defined in the specifications included herewith.

Combined Service and Goods: The scope of the service and deliverable goods to be provided will be more clearly defined in the specifications included herewith.

One Time Purchase: This Contract is for the purchase of a set quantity of goods that are identified in the specifications included herewith. Once those items have been delivered, no additional goods may be procured under this Contract without an appropriate change order approved by the Vendor, Agency, Purchasing Division, and Attorney General's office.

6. EMERGENCY PURCHASES: The Purchasing Division Director may authorize the Agency to purchase goods or services in the open market that Vendor would otherwise provide under this Contract if those goods or services are for immediate or expedited delivery in an emergency. Emergencies shall include, but are not limited to, delays in transportation or an unanticipated increase in the volume of work. An emergency purchase in the open market, approved by the Purchasing Division Director, shall not constitute of breach of this Contract and shall not entitle the Vendor to any form of compensation or damages. This provision does not excuse the State from fulfilling its obligations under a One Time Purchase contract.

7. REQUIRED DOCUMENTS: All of the items checked below must be provided to the Purchasing Division by the Vendor as specified below.

BID BOND (Construction Only): Pursuant to the requirements contained in W. Va. Code § 5-22-1(c), All Vendors submitting a bid on a construction project shall furnish a valid bid bond in the amount of five percent (5%) of the total amount of the bid protecting the State of West Virginia. The bid bond must be submitted with the bid.

PERFORMANCE BOND: The apparent successful Vendor shall provide a performance bond in the amount of 100% of the contract. The performance bond must be received by the Purchasing Division prior to Contract award.

LABOR/MATERIAL PAYMENT BOND: The apparent successful Vendor shall provide a labor/material payment bond in the amount of 100% of the Contract value. The labor/material payment bond must be delivered to the Purchasing Division prior to Contract award.

In lieu of the Bid Bond, Performance Bond, and Labor/Material Payment Bond, the Vendor may provide certified checks, cashier's checks, or irrevocable letters of credit. Any certified check, cashier's check, or irrevocable letter of credit provided in lieu of a bond must be of the same amount and delivered on the same schedule as the bond it replaces. A letter of credit submitted in lieu of a performance and labor/material payment bond will only be allowed for projects under \$100,000. Personal or business checks are not acceptable. Notwithstanding the foregoing, West Virginia Code § 5-22-1 (d) mandates that a vendor provide a performance and labor/material payment bond for construction projects. Accordingly, substitutions for the performance and labor/material payment bonds for construction projects is not permitted.

MAINTENANCE BOND: The apparent successful Vendor shall provide a two (2) year maintenance bond covering the roofing system. The maintenance bond must be issued and delivered to the Purchasing Division prior to Contract award.

LICENSE(S) / CERTIFICATIONS / PERMITS: In addition to anything required under the Section of the General Terms and Conditions entitled Licensing, the apparent successful Vendor shall furnish proof of the following licenses, certifications, and/or permits prior to Contract award, in a form acceptable to the Purchasing Division.

The apparent successful Vendor shall also furnish proof of any additional licenses or certifications contained in the specifications prior to Contract award regardless of whether or not that requirement is listed above.

8. INSURANCE: The apparent successful Vendor shall furnish proof of the insurance identified by a checkmark below and must include the State as an additional insured on each policy prior to Contract award. The insurance coverages identified below must be maintained throughout the life of this contract. Thirty (30) days prior to the expiration of the insurance policies, Vendor shall provide the Agency with proof that the insurance mandated herein has been continued. Vendor must also provide Agency with immediate notice of any changes in its insurance policies, including but not limited to, policy cancelation, policy reduction, or change in insurers. The apparent successful Vendor shall also furnish proof of any additional insurance requirements contained in the specifications prior to Contract award regardless of whether or not that insurance requirement is listed in this section.

Vendor must maintain:

- Commercial General Liability Insurance** in at least an amount of: \$1,000,000.00 per occurrence.
- Automobile Liability Insurance** in at least an amount of: \$1,000,000.00 per occurrence.
- Professional/Malpractice/Errors and Omission Insurance** in at least an amount of: _____ per occurrence.
- Commercial Crime and Third Party Fidelity Insurance** in an amount of: _____ per occurrence.
- Cyber Liability Insurance** in an amount of: _____ per occurrence.
- Builders Risk Insurance** in an amount equal to 100% of the amount of the Contract.
- Pollution Insurance** in an amount of: _____ per occurrence.
- Aircraft Liability** in an amount of: _____ per occurrence.
-
-
-
-



CERTIFICATE OF LIABILITY INSURANCE

DATE (MM/DD/YYYY)

04/05/2019

THIS CERTIFICATE IS ISSUED AS A MATTER OF INFORMATION ONLY AND CONFERS NO RIGHTS UPON THE CERTIFICATE HOLDER. THIS CERTIFICATE DOES NOT AFFIRMATIVELY OR NEGATIVELY AMEND, EXTEND OR ALTER THE COVERAGE AFFORDED BY THE POLICIES BELOW. THIS CERTIFICATE OF INSURANCE DOES NOT CONSTITUTE A CONTRACT BETWEEN THE ISSUING INSURER(S), AUTHORIZED REPRESENTATIVE OR PRODUCER, AND THE CERTIFICATE HOLDER.

IMPORTANT: If the certificate holder is an ADDITIONAL INSURED, the policy(ies) must have ADDITIONAL INSURED provisions or be endorsed. If SUBROGATION IS WAIVED, subject to the terms and conditions of the policy, certain policies may require an endorsement. A statement on this certificate does not confer rights to the certificate holder in lieu of such endorsement(s).

PRODUCER Martin's Insurance Group PO Box 1049 London KY 40743		CONTACT NAME: Wanda Evans PHONE (A/C, No, Ext): (606) 330-0405 FAX (A/C, No): (606) 330-0442 E-MAIL ADDRESS: wandaevans@martinsinsurancegroup.com	
INSURED		INSURER(S) AFFORDING COVERAGE	
Martins Peterbilt of West Virginia 715 Orchard Park Road Hurricane, WV 25526		INSURER A: WESTFIELD INS CO INSURER B: NORTHSTONE INS CO INSURER C: INSURER D: INSURER E: INSURER F:	NAIC # 24112 13045

COVERAGES**CERTIFICATE NUMBER:****REVISION NUMBER:**

THIS IS TO CERTIFY THAT THE POLICIES OF INSURANCE LISTED BELOW HAVE BEEN ISSUED TO THE INSURED NAMED ABOVE FOR THE POLICY PERIOD INDICATED. NOTWITHSTANDING ANY REQUIREMENT, TERM OR CONDITION OF ANY CONTRACT OR OTHER DOCUMENT WITH RESPECT TO WHICH THIS CERTIFICATE MAY BE ISSUED OR MAY PERTAIN, THE INSURANCE AFFORDED BY THE POLICIES DESCRIBED HEREIN IS SUBJECT TO ALL THE TERMS, EXCLUSIONS AND CONDITIONS OF SUCH POLICIES. LIMITS SHOWN MAY HAVE BEEN REDUCED BY PAID CLAIMS.

INSR LTR	TYPE OF INSURANCE	ADDL SUBR INSD / WVD	POLICY NUMBER	POLICY EFF (MM/DD/YYYY)	POLICY EXP (MM/DD/YYYY)	LIMITS
A	<input checked="" type="checkbox"/> COMMERCIAL GENERAL LIABILITY <input type="checkbox"/> CLAIMS-MADE <input type="checkbox"/> OCCUR GEN'L AGGREGATE LIMIT APPLIES PER: <input checked="" type="checkbox"/> POLICY <input type="checkbox"/> PRO-JECT <input type="checkbox"/> LOC OTHER:	x	CMM3399175	01/15/2019	01/15/2020	EACH OCCURRENCE \$ 1,000,000 DAMAGE TO RENTED PREMISES (Ea occurrence) \$ 100,000 MED EXP (Any one person) \$ 5,000 PERSONAL & ADV INJURY \$ 1,000,000 GENERAL AGGREGATE \$ 3,000,000 PRODUCTS - COMP/OP AGG \$ 3,000,000
A	AUTOMOBILE LIABILITY <input type="checkbox"/> ANY AUTO <input type="checkbox"/> OWNED AUTOS ONLY <input type="checkbox"/> SCHEDULED AUTOS <input type="checkbox"/> HIRED AUTOS ONLY <input type="checkbox"/> NON-OWNED AUTOS ONLY		CMM3399175	01/15/2019	01/15/2020	COMBINED SINGLE LIMIT (Ea accident) \$ 1,000,000 BODILY INJURY (Per person) \$ BODILY INJURY (Per accident) \$ PROPERTY DAMAGE (Per accident) \$
A	<input checked="" type="checkbox"/> UMBRELLA LIAB <input type="checkbox"/> OCCUR <input type="checkbox"/> EXCESS LIAB <input type="checkbox"/> CLAIMS-MADE DED RETENTION \$		CMM3399175	01/15/2019	01/15/2020	EACH OCCURRENCE \$ 10,000,000 AGGREGATE \$ 10,000,000 PR/COMP OPS AGG \$ 10,000,000
B	WORKERS COMPENSATION AND EMPLOYERS' LIABILITY ANY PROPRIETOR/PARTNER/EXECUTIVE OFFICER/MEMBER EXCLUDED? (Mandatory in NH) If yes, describe under DESCRIPTION OF OPERATIONS below	Y/N N	WCN6001353	09/12/2019	09/12/2020	PER STATUTE OTH-ER E.L. EACH ACCIDENT \$ 1,000,000 E.L. DISEASE - EA EMPLOYEE \$ 1,000,000 E.L. DISEASE - POLICY LIMIT \$ 1,000,000

DESCRIPTION OF OPERATIONS / LOCATIONS / VEHICLES (ACORD 101, Additional Remarks Schedule, may be attached if more space is required)

Martins Truck Parts and Sales and Martins Peterbilt of West Virginia are the same company.

CERTIFICATE HOLDER**CANCELLATION**

SHOULD ANY OF THE ABOVE DESCRIBED POLICIES BE CANCELLED BEFORE THE EXPIRATION DATE THEREOF, NOTICE WILL BE DELIVERED IN ACCORDANCE WITH THE POLICY PROVISIONS.

AUTHORIZED REPRESENTATIVE

Scarlet Lunsford

© 1988-2015 ACORD CORPORATION. All rights reserved.

Notwithstanding anything contained in this section to the contrary, the Director of the Purchasing Division reserves the right to waive the requirement that the State be named as an additional insured on one or more of the Vendor's insurance policies if the Director finds that doing so is in the State's best interest.

9. WORKERS' COMPENSATION INSURANCE: The apparent successful Vendor shall comply with laws relating to workers compensation, shall maintain workers' compensation insurance when required, and shall furnish proof of workers' compensation insurance upon request.

10. [Reserved]

11. LIQUIDATED DAMAGES: This clause shall in no way be considered exclusive and shall not limit the State or Agency's right to pursue any other available remedy. Vendor shall pay liquidated damages in the amount specified below or as described in the specifications:

_____ for _____

Liquidated Damages Contained in the Specifications

12. ACCEPTANCE: Vendor's signature on its bid, or on the certification and signature page, constitutes an offer to the State that cannot be unilaterally withdrawn, signifies that the product or service proposed by vendor meets the mandatory requirements contained in the Solicitation for that product or service, unless otherwise indicated, and signifies acceptance of the terms and conditions contained in the Solicitation unless otherwise indicated.

13. PRICING: The pricing set forth herein is firm for the life of the Contract, unless specified elsewhere within this Solicitation/Contract by the State. A Vendor's inclusion of price adjustment provisions in its bid, without an express authorization from the State in the Solicitation to do so, may result in bid disqualification.

14. PAYMENT IN ARREARS: Payment in advance is prohibited under this Contract. Payment may only be made after the delivery and acceptance of goods or services. The Vendor shall submit invoices, in arrears.

15. PAYMENT METHODS: Vendor must accept payment by electronic funds transfer and P-Card. (The State of West Virginia's Purchasing Card program, administered under contract by a banking institution, processes payment for goods and services through state designated credit cards.)

16. TAXES: The Vendor shall pay any applicable sales, use, personal property or any other taxes arising out of this Contract and the transactions contemplated thereby. The State of West Virginia is exempt from federal and state taxes and will not pay or reimburse such taxes.

17. ADDITIONAL FEES: Vendor is not permitted to charge additional fees or assess additional charges that were not either expressly provided for in the solicitation published by the State of West Virginia or included in the unit price or lump sum bid amount that Vendor is required by the solicitation to provide. Including such fees or charges as notes to the solicitation may result in rejection of vendor's bid. Requesting such fees or charges be paid after the contract has been awarded may result in cancellation of the contract.

18. FUNDING: This Contract shall continue for the term stated herein, contingent upon funds being appropriated by the Legislature or otherwise being made available. In the event funds are not appropriated or otherwise made available, this Contract becomes void and of no effect beginning on July 1 of the fiscal year for which funding has not been appropriated or otherwise made available.

19. CANCELLATION: The Purchasing Division Director reserves the right to cancel this Contract immediately upon written notice to the vendor if the materials or workmanship supplied do not conform to the specifications contained in the Contract. The Purchasing Division Director may also cancel any purchase or Contract upon 30 days written notice to the Vendor in accordance with West Virginia Code of State Rules § 148-1-5.2.b.

20. TIME: Time is of the essence with regard to all matters of time and performance in this Contract.

21. APPLICABLE LAW: This Contract is governed by and interpreted under West Virginia law without giving effect to its choice of law principles. Any information provided in specification manuals, or any other source, verbal or written, which contradicts or violates the West Virginia Constitution, West Virginia Code or West Virginia Code of State Rules is void and of no effect.

22. COMPLIANCE WITH LAWS: Vendor shall comply with all applicable federal, state, and local laws, regulations and ordinances. By submitting a bid, Vendor acknowledges that it has reviewed, understands, and will comply with all applicable laws, regulations, and ordinances.

SUBCONTRACTOR COMPLIANCE: Vendor shall notify all subcontractors providing commodities or services related to this Contract that as subcontractors, they too are required to comply with all applicable laws, regulations, and ordinances. Notification under this provision must occur prior to the performance of any work under the contract by the subcontractor.

23. ARBITRATION: Any references made to arbitration contained in this Contract, Vendor's bid, or in any American Institute of Architects documents pertaining to this Contract are hereby deleted, void, and of no effect.

24. MODIFICATIONS: This writing is the parties' final expression of intent. Notwithstanding anything contained in this Contract to the contrary no modification of this Contract shall be binding without mutual written consent of the Agency, and the Vendor, with approval of the Purchasing Division and the Attorney General's office (Attorney General approval is as to form only). Any change to existing contracts that adds work or changes contract cost, and were not included in the original contract, must be approved by the Purchasing Division and the Attorney General's Office (as to form) prior to the implementation of the change or commencement of work affected by the change.

25. WAIVER: The failure of either party to insist upon a strict performance of any of the terms or provision of this Contract, or to exercise any option, right, or remedy herein contained, shall not be construed as a waiver or a relinquishment for the future of such term, provision, option, right, or remedy, but the same shall continue in full force and effect. Any waiver must be expressly stated in writing and signed by the waiving party.

26. SUBSEQUENT FORMS: The terms and conditions contained in this Contract shall supersede any and all subsequent terms and conditions which may appear on any form documents submitted by Vendor to the Agency or Purchasing Division such as price lists, order forms, invoices, sales agreements, or maintenance agreements, and includes internet websites or other electronic documents. Acceptance or use of Vendor's forms does not constitute acceptance of the terms and conditions contained thereon.

27. ASSIGNMENT: Neither this Contract nor any monies due, or to become due hereunder, may be assigned by the Vendor without the express written consent of the Agency, the Purchasing Division, the Attorney General's office (as to form only), and any other government agency or office that may be required to approve such assignments.

28. WARRANTY: The Vendor expressly warrants that the goods and/or services covered by this Contract will: (a) conform to the specifications, drawings, samples, or other description furnished or specified by the Agency; (b) be merchantable and fit for the purpose intended; and (c) be free from defect in material and workmanship.

29. STATE EMPLOYEES: State employees are not permitted to utilize this Contract for personal use and the Vendor is prohibited from permitting or facilitating the same.

30. PRIVACY, SECURITY, AND CONFIDENTIALITY: The Vendor agrees that it will not disclose to anyone, directly or indirectly, any such personally identifiable information or other confidential information gained from the Agency, unless the individual who is the subject of the information consents to the disclosure in writing or the disclosure is made pursuant to the Agency's policies, procedures, and rules. Vendor further agrees to comply with the Confidentiality Policies and Information Security Accountability Requirements, set forth in <http://www.state.wv.us/admin/purchase/privacy/default.html>.

31. YOUR SUBMISSION IS A PUBLIC DOCUMENT: Vendor's entire response to the Solicitation and the resulting Contract are public documents. As public documents, they will be disclosed to the public following the bid/proposal opening or award of the contract, as required by the competitive bidding laws of West Virginia Code §§ 5A-3-1 et seq., 5-22-1 et seq., and 5G-1-1 et seq. and the Freedom of Information Act West Virginia Code §§ 29B-1-i et seq.

DO NOT SUBMIT MATERIAL YOU CONSIDER TO BE CONFIDENTIAL, A TRADE SECRET, OR OTHERWISE NOT SUBJECT TO PUBLIC DISCLOSURE.

Submission of any bid, proposal, or other document to the Purchasing Division constitutes your explicit consent to the subsequent public disclosure of the bid, proposal, or document. The Purchasing Division will disclose any document labeled "confidential," "proprietary," "trade secret," "private," or labeled with any other claim against public disclosure of the documents, to include any "trade secrets" as defined by West Virginia Code § 47-22-1 et seq. All submissions are subject to public disclosure without notice.

32. LICENSING: In accordance with West Virginia Code of State Rules § 148-1-6.1.e, Vendor must be licensed and in good standing in accordance with any and all state and local laws and requirements by any state or local agency of West Virginia, including, but not limited to, the West Virginia Secretary of State's Office, the West Virginia Tax Department, West Virginia Insurance Commission, or any other state agency or political subdivision. Obligations related to political subdivisions may include, but are not limited to, business licensing, business and occupation taxes, inspection compliance, permitting, etc. Upon request, the Vendor must provide all necessary releases to obtain information to enable the Purchasing Division Director or the Agency to verify that the Vendor is licensed and in good standing with the above entities.

SUBCONTRACTOR COMPLIANCE: Vendor shall notify all subcontractors providing commodities or services related to this Contract that as subcontractors, they too are required to be licensed, in good standing, and up-to-date on all state and local obligations as described in this section. Obligations related to political subdivisions may include, but are not limited to, business licensing, business and occupation taxes, inspection compliance, permitting, etc. Notification under this provision must occur prior to the performance of any work under the contract by the subcontractor.

33. ANTITRUST: In submitting a bid to, signing a contract with, or accepting a Award Document from any agency of the State of West Virginia, the Vendor agrees to convey, sell, assign, or transfer to the State of West Virginia all rights, title, and interest in and to all causes of action it may now or hereafter acquire under the antitrust laws of the United States and the State of West Virginia for price fixing and/or unreasonable restraints of trade relating to the particular commodities or services purchased or acquired by the State of West Virginia. Such assignment shall be made and become effective at the time the purchasing agency tenders the initial payment to Vendor.

34. VENDOR CERTIFICATIONS: By signing its bid or entering into this Contract, Vendor certifies (1) that its bid or offer was made without prior understanding, agreement, or connection with any corporation, firm, limited liability company, partnership, person or entity submitting a bid or offer for the same material, supplies, equipment or services; (2) that its bid or offer is in all respects fair and without collusion or fraud; (3) that this Contract is accepted or entered into without any prior understanding, agreement, or connection to any other entity that could be considered a violation of law; and (4) that it has reviewed this Solicitation in its entirety; understands the requirements, terms and conditions, and other information contained herein.

Vendor's signature on its bid or offer also affirms that neither it nor its representatives have any interest, nor shall acquire any interest, direct or indirect, which would compromise the performance of its services hereunder. Any such interests shall be promptly presented in detail to the Agency. The individual signing this bid or offer on behalf of Vendor certifies that he or she is authorized by the Vendor to execute this bid or offer or any documents related thereto on Vendor's behalf; that he or she is authorized to bind the Vendor in a contractual relationship; and that, to the best of his or her knowledge, the Vendor has properly registered with any State agency that may require registration.

35. VENDOR RELATIONSHIP: The relationship of the Vendor to the State shall be that of an independent contractor and no principal-agent relationship or employer-employee relationship is contemplated or created by this Contract. The Vendor as an independent contractor is solely liable for the acts and omissions of its employees and agents. Vendor shall be responsible for selecting, supervising, and compensating any and all individuals employed pursuant to the terms of this Solicitation and resulting contract. Neither the Vendor, nor any employees or subcontractors of the Vendor, shall be deemed to be employees of the State for any purpose whatsoever. Vendor shall be exclusively responsible for payment of employees and contractors for all wages and salaries, taxes, withholding payments, penalties, fees, fringe benefits, professional liability insurance premiums, contributions to insurance and pension, or other deferred compensation plans, including but not limited to, Workers' Compensation and Social Security obligations, licensing fees, etc. and the filing of all necessary documents, forms, and returns pertinent to all of the foregoing.

Vendor shall hold harmless the State, and shall provide the State and Agency with a defense against any and all claims including, but not limited to, the foregoing payments, withholdings, contributions, taxes, Social Security taxes, and employer income tax returns.

36. INDEMNIFICATION: The Vendor agrees to indemnify, defend, and hold harmless the State and the Agency, their officers, and employees from and against: (1) Any claims or losses for services rendered by any subcontractor, person, or firm performing or supplying services, materials, or supplies in connection with the performance of the Contract; (2) Any claims or losses resulting to any person or entity injured or damaged by the Vendor, its officers, employees, or subcontractors by the publication, translation, reproduction, delivery, performance, use, or disposition of any data used under the Contract in a manner not authorized by the Contract, or by Federal or State statutes or regulations; and (3) Any failure of the Vendor, its officers, employees, or subcontractors to observe State and Federal laws including, but not limited to, labor and wage and hour laws.

37. PURCHASING AFFIDAVIT: In accordance with West Virginia Code §§ 5A-3-10a and 5-22-1(i), the State is prohibited from awarding a contract to any bidder that owes a debt to the State or a political subdivision of the State, Vendors are required to sign, notarize, and submit the Purchasing Affidavit to the Purchasing Division affirming under oath that it is not in default on any monetary obligation owed to the state or a political subdivision of the state.

38. ADDITIONAL AGENCY AND LOCAL GOVERNMENT USE: This Contract may be utilized by other agencies, spending units, and political subdivisions of the State of West Virginia; county, municipal, and other local government bodies; and school districts ("Other Government Entities"), provided that both the Other Government Entity and the Vendor agree. Any extension of this Contract to the aforementioned Other Government Entities must be on the same prices, terms, and conditions as those offered and agreed to in this Contract, provided that such extension is in compliance with the applicable laws, rules, and ordinances of the Other Government Entity. A refusal to extend this Contract to the Other Government Entities shall not impact or influence the award of this Contract in any manner.

39. CONFLICT OF INTEREST: Vendor, its officers or members or employees, shall not presently have or acquire an interest, direct or indirect, which would conflict with or compromise the performance of its obligations hereunder. Vendor shall periodically inquire of its officers, members and employees to ensure that a conflict of interest does not arise. Any conflict of interest discovered shall be promptly presented in detail to the Agency.

40. REPORTS: Vendor shall provide the Agency and/or the Purchasing Division with the following reports identified by a checked box below:

Such reports as the Agency and/or the Purchasing Division may request. Requested reports may include, but are not limited to, quantities purchased, agencies utilizing the contract, total contract expenditures by agency, etc.

Quarterly reports detailing the total quantity of purchases in units and dollars, along with a listing of purchases by agency. Quarterly reports should be delivered to the Purchasing Division via email at purchasing.requisitions@wv.gov.

41. BACKGROUND CHECK: In accordance with W. Va. Code § 15-2D-3, the Director of the Division of Protective Services shall require any service provider whose employees are regularly employed on the grounds or in the buildings of the Capitol complex or who have access to sensitive or critical information to submit to a fingerprint-based state and federal background inquiry through the state repository. The service provider is responsible for any costs associated with the fingerprint-based state and federal background inquiry.

After the contract for such services has been approved, but before any such employees are permitted to be on the grounds or in the buildings of the Capitol complex or have access to sensitive or critical information, the service provider shall submit a list of all persons who will be physically present and working at the Capitol complex to the Director of the Division of Protective Services for purposes of verifying compliance with this provision. The State reserves the right to prohibit a service provider's employees from accessing sensitive or critical information or to be present at the Capitol complex based upon results addressed from a criminal background check.

Revised 06/08/2018

Service providers should contact the West Virginia Division of Protective Services by phone at (304) 558-9911 for more information.

42. PREFERENCE FOR USE OF DOMESTIC STEEL PRODUCTS: Except when authorized by the Director of the Purchasing Division pursuant to W. Va. Code § 5A-3-56, no contractor may use or supply steel products for a State Contract Project other than those steel products made in the United States. A contractor who uses steel products in violation of this section may be subject to civil penalties pursuant to W. Va. Code § 5A-3-56. As used in this section:

- a. "State Contract Project" means any erection or construction of, or any addition to, alteration of or other improvement to any building or structure, including, but not limited to, roads or highways, or the installation of any heating or cooling or ventilating plants or other equipment, or the supply of and materials for such projects, pursuant to a contract with the State of West Virginia for which bids were solicited on or after June 6, 2001.
- b. "Steel Products" means products rolled, formed, shaped, drawn, extruded, forged, cast, fabricated or otherwise similarly processed, or processed by a combination of two or more or such operations, from steel made by the open hearth, basic oxygen, electric furnace, Bessemer or other steel making process. The Purchasing Division Director may, in writing, authorize the use of foreign steel products if:
- c. The cost for each contract item used does not exceed one tenth of one percent (.1%) of the total contract cost or two thousand five hundred dollars (\$2,500.00), whichever is greater. For the purposes of this section, the cost is the value of the steel product as delivered to the project; or
- d. The Director of the Purchasing Division determines that specified steel materials are not produced in the United States in sufficient quantity or otherwise are not reasonably available to meet contract requirements.

43. PREFERENCE FOR USE OF DOMESTIC ALUMINUM, GLASS, AND STEEL: In Accordance with W. Va. Code § 5-19-1 et seq., and W. Va. CSR § 148-10-1 et seq., for every contract or subcontract, subject to the limitations contained herein, for the construction, reconstruction, alteration, repair, improvement or maintenance of public works or for the purchase of any item of machinery or equipment to be used at sites of public works, only domestic aluminum, glass or steel products shall be supplied unless the spending officer determines, in writing, after the receipt of offers or bids, (1) that the cost of domestic aluminum, glass or steel products is unreasonable or inconsistent with the public interest of the State of West Virginia, (2) that domestic aluminum, glass or steel products are not produced in sufficient quantities to meet the contract requirements, or (3) the available domestic aluminum, glass, or steel do not meet the contract specifications. This provision only applies to public works contracts awarded in an amount more than fifty thousand dollars (\$50,000) or public works contracts that require more than ten thousand pounds of steel products.

The cost of domestic aluminum, glass, or steel products may be unreasonable if the cost is more than twenty percent (20%) of the bid or offered price for foreign made aluminum, glass, or steel products. If the domestic aluminum, glass or steel products to be supplied or produced in a

“substantial labor surplus area”, as defined by the United States Department of Labor, the cost of domestic aluminum, glass, or steel products may be unreasonable if the cost is more than thirty percent (30%) of the bid or offered price for foreign made aluminum, glass, or steel products. This preference shall be applied to an item of machinery or equipment, as indicated above, when the item is a single unit of equipment or machinery manufactured primarily of aluminum, glass or steel, is part of a public works contract and has the sole purpose or of being a permanent part of a single public works project. This provision does not apply to equipment or machinery purchased by a spending unit for use by that spending unit and not as part of a single public works project.

All bids and offers including domestic aluminum, glass or steel products that exceed bid or offer prices including foreign aluminum, glass or steel products after application of the preferences provided in this provision may be reduced to a price equal to or lower than the lowest bid or offer price for foreign aluminum, glass or steel products plus the applicable preference. If the reduced bid or offer prices are made in writing and supersede the prior bid or offer prices, all bids or offers, including the reduced bid or offer prices, will be reevaluated in accordance with this rule.

44. INTERESTED PARTY SUPPLEMENTAL DISCLOSURE: W. Va. Code § 6D-1-2 requires that for contracts with an actual or estimated value of at least \$1 million, the vendor must submit to the Agency a supplemental disclosure of interested parties reflecting any new or differing interested parties to the contract, which were not included in the original pre-award interested party disclosure, within 30 days following the completion or termination of the contract. A copy of that form is included with this solicitation or can be obtained from the WV Ethics Commission. This requirement does not apply to publicly traded companies listed on a national or international stock exchange. A more detailed definition of interested parties can be obtained from the form referenced above.

DESIGNATED CONTACT: Vendor appoints the individual identified in this Section as the Contract Administrator and the initial point of contact for matters relating to this Contract.

Sales Assistant

(Name, Title) Jonathan Burns Sales Assistant
(Printed Name and Title) 715 Orchard Park Rd, Hurricane Wv 25526
(Address) (304)562-7999 (855)849-7470
(Phone Number) / (Fax Number) jb@martinspeterbilt.com
(email address)

CERTIFICATION AND SIGNATURE: By signing below, or submitting documentation through wvOASIS, I certify that I have reviewed this Solicitation in its entirety; that I understand the requirements, terms and conditions, and other information contained herein; that this bid, offer or proposal constitutes an offer to the State that cannot be unilaterally withdrawn; that the product or service proposed meets the mandatory requirements contained in the Solicitation for that product or service, unless otherwise stated herein; that the Vendor accepts the terms and conditions contained in the Solicitation, unless otherwise stated herein; that I am submitting this bid, offer or proposal for review and consideration; that I am authorized by the vendor to execute and submit this bid, offer, or proposal, or any documents related thereto on vendor's behalf; that I am authorized to bind the vendor in a contractual relationship; and that to the best of my knowledge, the vendor has properly registered with any State agency that may require registration.

Martins Peterbilt

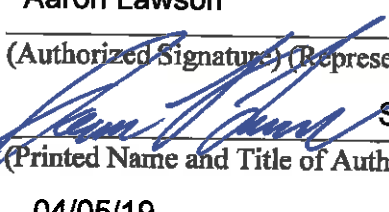
(Company) Aaron Lawson Sales Representative
(Authorized Signature) (Representative Name, Title)  Sales Representative
(Printed Name and Title of Authorized Representative)
04/05/19
(Date) (304)562-7999 (855)849-7470
(Phone Number) (Fax Number)

REQUEST FOR QUOTATION
2018 or Newer Class 8 Extended Day Cab Tandem Tractor

SPECIFICATIONS

1. **PURPOSE AND SCOPE:** The West Virginia Purchasing Division is soliciting bids on behalf of West Virginia State Agency for Surplus Property to establish a contract for the one-time purchase of a 2018 or newer, Class 8 Extended Day Cab Tandem Tractor.
2. **DEFINITIONS:** The terms listed below shall have the meanings assigned to them below. Additional definitions can be found in section 2 of the General Terms and Conditions.
 - 2.1. **“Contract Item”** means 2018 or newer, Class 8 Extended Day Cab Tandem Tractor as more fully described by these specifications.
 - 2.2. **“Pricing Page”** means the pages, contained in wvOASIS or attached as Exhibit A, upon which Vendor should list its proposed price for the Contract Items.
 - 2.3. **“Solicitation”** means the official notice of an opportunity to supply the State with goods or services that is published by the Purchasing Division.
 - 2.4. **“WVSASP”** means the purchasing agency, West Virginia State Agency for Surplus Property.
 - 2.5. **“Class 8”** means the gross vehicle weight rating (GVWR) is a vehicle with GVWR exceeding 33000 lb. (14969 kg).
 - 2.6. **“S CAM BRAKES”** means an S-cam is part of a braking system used in heavy vehicles such as trucks and wheeled machinery. It consists of a shaft, usually around 4 to 25 inches long, turned at one end by means of an air-powered brake booster and lever with an “S” shaped cam at the wheel end.
 - 2.7. **“Day Cab”** means single or tandem drive axles but without a sleeper area.
3. **GENERAL REQUIREMENTS:**
 - 3.1. **Mandatory Contract Item Requirements:** Contract Item must meet or exceed the mandatory requirements listed below.
 - 3.1.1. **2018 or latest year model, Class 8 Tandem Tractor**
 - 3.1.1.1. Must be a new, untitled unit.
 - 3.1.2. **Cab & Equipment**

REQUEST FOR QUOTATION
2018 or Newer Class 8 Extended Day Cab Tandem Tractor

- 3.1.2.1.** Must be an **extended day cab** or equivalent, but not a sleeper unit.
- 3.1.2.2.** Cab interior must have air conditioning with heat and filters.
- 3.1.2.3.** Must have power steering with adjustable telescoping tilt steering column.
- 3.1.2.4.** Must include 4 (four) sets of keys, minimum.
- 3.1.2.5.** Must have left and right-side rubber floor mats. NO interior carpet.
- 3.1.2.6.** Driver and passenger seat must be high back air ride seats. NO cloth seats.
- 3.1.2.7.** Must have minimum of AM-FM radio with Bluetooth capability.
- 3.1.2.8.** Must have CB radio including mounted antenna. Truck must be prewired for radio.
- 3.1.2.9.** Must have left and right motorized, built in convex heated mirrors.
- 3.1.2.10.** Must have left and right electric-powered door window lifts and door locks.
- 3.1.2.11.** Must have Sun Visor-Interior- both sides padded.
- 3.1.2.12.** Must include all safety equipment mandated by Section 393 of the Federal Code of Regulations.
- 3.1.2.13.** Must have marker lights on bottom of cab.
- 3.1.2.14.** Must have yellow strobe light(s) bar(s), minimum 24", on top of cab. Any model.
- 3.1.2.15.** Must be Navy blue in color.
- 3.1.2.16.** Must have exterior, minimum 9" drop, brushed aluminum sun visor.
- 3.1.2.17.** Must have a minimum of forty-eight and one-half inches (48 ½) distance from where the firewall meets the floorboard to the rear of the seat base.
- 3.1.3. Engine/Powertrain & Equipment**
 - 3.1.3.1.** Must have Cummins ISX15 or Detroit DD15 or Equal engine. Minimum of a 500-horsepower engine with a minimum of 1850 torque.

REQUEST FOR QUOTATION
2018 or Newer Class 8 Extended Day Cab Tandem Tractor

3.1.3.2. Must have engine brake.

3.1.3.3. Must have dual vertical stainless steel exhaust stand pipes and 15" (fifteen inch) stainless-steel breathers. The stand exhaust pipes must be a minimum of 48" (forty-eight inches) above the truck cab.

3.1.3.4. Must have cruise control.

3.1.3.5. Must have 18 speed manual transmission.

3.1.3.6. Must have minimum 1200-watt immersion block heater.

3.1.3.7. Must have air dryer.

3.1.4. Tires/Frame & Equipment

3.1.4.1. Must have brushed aluminum wheels.

3.1.4.2. Must have cat walk behind cab on frame.

3.1.4.3. Must have all pigtails (air brake hose and light cable connections) spring mounted support.

3.1.4.4. Tires must be Low Profile 24.5 All season rear and Steer tire front, 16 ply minimums.

3.1.4.5. Brakes must be "S" cam brakes with auto adjusters

3.1.4.6. Must have poly fenders over rear axles with mud flaps.

3.1.4.7. Must have basic standard size air slide fifth wheel with a maximum height not to exceed fifty-inches (50) from the ground to the top of the fifth wheel with the fifth wheel setting in the level position.

3.1.4.8. Front axle must be minimum 12,000 lb. capacity, NO set-back front axle.

3.1.4.9. Tandem rear axle must be minimum 40,000 lb. capacity.

3.1.4.10. Must have a single wet line package (relief valve not required) installed (in cab controlled) (1 ½ inch quick connect fittings), to operate the following equipment: Box Trailer, Flat Bed Trailer, Low Boy Trailer and a Thirty-Six (36) foot End Dump Trailer. Must have a minimum of a 60-

REQUEST FOR QUOTATION
2018 or Newer Class 8 Extended Day Cab Tandem Tractor

gallon hydraulic tank incorporated in the split fuel tank.

- 3.1.4.11.** Must have driver controlled full locker with independent switches. Must have an air ride suspension with inside cab mount dump valve.
 - 3.1.4.12.** Geared to maintain 70 mph at 1150-1350 rpm below governor on engine.
 - 3.1.4.13.** Must have license plate mounts located on front bumper and rear of tractor. Must be pre-drilled with hardware installed to meet specifications that require both front and rear license plates.
 - 3.1.4.14.** Must have dual diesel fuel (minimum of 200-gallon capacity total) (minimum 25" (twenty-five inch) diameter) polished tanks. The fuel tanks may be in various capacities to allow for the Diesel Exhaust Fuel (DEF) tank and must be installed with the DEF tank in mind to set properly on the truck. One of the fuel tanks will also have a minimum of a 60-gallon hydraulic tank incorporated in the split fuel tank. Fuel tanks are to have four polished straps each and **are not** to be mounted under the doors or used as steps to the cab.
 - 3.1.4.15.** Must have aluminum headache rack with rear facing lights.
 - 3.1.4.16.** Must have a wheelbase between 235" and 260"
- 3.1.5. Preelivery Inspection:** Prior to delivery, vehicle must be thoroughly inspected and serviced in compliance with the manufacturer's prescribed procedures which includes but are not limited to:
- Completely lubricate vehicle. Check all oil levels and top off all fluids. Adjust engine to proper operating condition. Check alignment and balance tires if needed. Verify tire pressure and correct as necessary. Perform operational checks which will cover all controls, systems, devices, doors, windows and accessories. Any deficiencies must be addressed before delivery. No dealer insignia or other advertising shall be affixed to the vehicle or appear on any accessory. Vehicle delivered with such will be rejected.
- A.** Must have a valid West Virginia State Inspection Sticker on the windshield. The vehicle must be inspected in the month delivered.

REQUEST FOR QUOTATION
2018 or Newer Class 8 Extended Day Cab Tandem Tractor

- B. Wash/Clean interior and exterior of vehicle. Remove all unnecessary tags, stickers. Window stickers may be removed and placed inside the cab.
 - C. Upon delivery, vehicle shall have a minimum of 200-gallon of fuel in the fuel tanks.
- 3.1.6. **Workmanship:** Vehicle shall be free of defects that may impair their operation, safety, emissions and serviceability or detract from appearance.
- 3.1.7. **Statement of Origin/Bill of Sale:** Manufacturer's Statement of Origin or Bill of Sale shall be provided to WVSASP showing applicable purchase order number. All documentation, including but not limited to, Title Application, Delivery/Odometer Statement in original form must be mailed prior to delivery of vehicle or hand carried on day of vehicle delivery to WVSASP.
- 3.1.8. **Warranty/Operator's Manual:** Manufacturer or Vendor shall furnish at least 1 (one) copy of all warranty information, operator's manual and handbooks for any special equipment furnished with it or as part of the vehicle.
- 3.1.8.1. **Basic Comprehensive Warranty Coverage:** Vendor shall provide the vehicle manufacturer's base vehicle warranty. The minimum length shall be 1 years/100,000 miles.
 - 3.1.8.2. **Basic Corrosion and Powertrain Warranty Coverage:** Vendor shall provide the manufacturer's standard Basic Corrosion and Powertrain Warranty.
4. **CONTRACT AWARD:**
- 4.1. **Contract Award:** The Contract is intended to provide Agencies with a purchase price for the Contract Items. The Contract shall be awarded to the Vendor that provides the Contract Items meeting the required specifications for the lowest overall total cost as shown on the Pricing Page.
 - 4.2. **Pricing Page:** Vendor should complete the Pricing Page by lump sum. Vendor should complete the Pricing Page in full as failure to complete the Pricing Page in its entirety may result in Vendor's bid being disqualified. (See *Exhibit A.*)
 - 4.2.1. Vendor should type or electronically enter the information into the Pricing Page to prevent errors in the evaluation.

REQUEST FOR QUOTATION
2018 or Newer Class 8 Extended Day Cab Tandem Tractor

4.2.2. Vendor's who wish to respond to a Centralized Request for Quotation (CRFQ) online may submit information through the State's wvOASIS Vendor Self Service (VSS). Vendors should download the Exhibit "A": Pricing Page that is attached separately to the CRFQ and published to the VSS. **Vendors must identify with their pricing information including Brand, Model and Year equipment being bid and include it as an attachment to their online response.** If unable to respond online Vendor must submit Pricing Pages in their entirety with your bid prior to the scheduled bid opening date and time.

5. PAYMENT: Vendor shall accept payment in accordance with the payment procedures of the State of West Virginia. Payment procedures may be found in the supplied Terms & Conditions.

6. DELIVERY AND RETURN:

6.1. Shipment and Delivery: The Agency prefers that the Vendor deliver the Contract Items within One-Hundred and Eighty (180) calendar days after receiving a purchase order or notice to proceed. Dealer Vendor must give the Agency a potential on-line date. Contract Items must be delivered to Agency at: **West Virginia State Agency for Surplus Property (WVSASP), 2700 Charles Avenue, Dunbar WV 25064.**

6.2. Late Delivery: The Agency placing the order under this Contract must be notified in writing if the shipment of the Contract Items will be delayed for any reason. Any delay in delivery that could cause harm to an Agency will be grounds for cancellation of the Contract, and/or obtaining the Contract Items from a third party.

Any Agency seeking to obtain the Contract Items from a third party under this provision must first obtain approval of the Purchasing Division.

6.3. Delivery Payment/Risk of Loss: Vendor shall deliver the Contract Items F.O.B. destination to the Agency's location.

6.4. Return of Unacceptable Items: If the Agency deems the Contract Items to be unacceptable, the Contract Items shall be returned to Vendor at Vendor's expense and with no restocking charge. Vendor shall either make arrangements for the return within five (5) days of being notified that items are unacceptable or permit the Agency to arrange for the return and reimburse Agency for delivery expenses. If the original packaging

REQUEST FOR QUOTATION
2018 or Newer Class 8 Extended Day Cab Tandem Tractor

cannot be utilized for the return, Vendor will supply the Agency with appropriate return packaging upon request. All returns of unacceptable items shall be F.O.B. the Agency's location. The returned product shall either be replaced, or the Agency shall receive a full credit or refund for the purchase price, at the Agency's discretion.

6.5. Return Due to Agency Error: Items ordered in error by the Agency will be returned for credit within 30 days of receipt, F.O.B. Vendor's location. Vendor shall not charge a restocking fee if returned products are in a resalable condition. Items shall be deemed to be in a resalable condition if they are unused and in the original packaging. Any restocking fee for items not in a resalable condition shall be the lower of the Vendor's customary restocking fee or 5% of the total invoiced value of the returned items.

7. VENDOR DEFAULT:

7.1. The following shall be considered a vendor default under this Contract.

7.1.1. Failure to provide Contract Items in accordance with the requirements contained herein.

7.1.2. Failure to comply with other specifications and requirements contained herein.

7.1.3. Failure to comply with any laws, rules, and ordinances applicable to the Contract Services provided under this Contract.

7.1.4. Failure to remedy deficient performance upon request.

7.2. The following remedies shall be available to Agency upon default.

7.2.1. Immediate cancellation of the Contract.

7.2.2. Immediate cancellation of one or more release orders issued under this Contract.

7.2.3. Any other remedies available in law or equity.

8. ATTACHMENTS:

8.1. Exhibit A – Pricing Page

Exhibit A Pricing Page
2018 or newer Class 8 DayCab Tandam Tractor
WV Surplus Property

Item No.	Description	Model No/Brand Name	Quantity	Unit Price	Extnded Cost
1	2018 or newer Class 8 Day Cab Tandem Tractor	389 Peterbilt Extended Day-Cab Tractor	1	\$ 131,928. ⁰⁰	
				Total Bid Amount	\$ 131,928. ⁰⁰

ADDENDUM ACKNOWLEDGEMENT FORM
SOLICITATION NO.:

Instructions: Please acknowledge receipt of all addenda issued with this solicitation by completing this addendum acknowledgment form. Check the box next to each addendum received and sign below. Failure to acknowledge addenda may result in bid disqualification.

Acknowledgment: I hereby acknowledge receipt of the following addenda and have made the necessary revisions to my proposal, plans and/or specification, etc.

Addendum Numbers Received:

(Check the box next to each addendum received)

- | | |
|---|--|
| <input type="checkbox"/> Addendum No. 1 | <input type="checkbox"/> Addendum No. 6 |
| <input type="checkbox"/> Addendum No. 2 | <input type="checkbox"/> Addendum No. 7 |
| <input type="checkbox"/> Addendum No. 3 | <input type="checkbox"/> Addendum No. 8 |
| <input type="checkbox"/> Addendum No. 4 | <input type="checkbox"/> Addendum No. 9 |
| <input type="checkbox"/> Addendum No. 5 | <input type="checkbox"/> Addendum No. 10 |

I understand that failure to confirm the receipt of addenda may be cause for rejection of this bid. I further understand that any verbal representation made or assumed to be made during any oral discussion held between Vendor's representatives and any state personnel is not binding. Only the information issued in writing and added to the specifications by an official addendum is binding.

Martins Peterbilt

Company

Authorized Signature

04/05/19

Date

NOTE: This addendum acknowledgment should be submitted with the bid to expedite document processing.

STATE OF WEST VIRGINIA
Purchasing Division

PURCHASING AFFIDAVIT

CONSTRUCTION CONTRACTS: Under W. Va. Code § 5-22-1(i), the contracting public entity shall not award a construction contract to any bidder that is known to be in default on any monetary obligation owed to the state or a political subdivision of the state, including, but not limited to, obligations related to payroll taxes, property taxes, sales and use taxes, fire service fees, or other fines or fees.

ALL CONTRACTS: Under W. Va. Code §5A-3-10a, no contract or renewal of any contract may be awarded by the state or any of its political subdivisions to any vendor or prospective vendor when the vendor or prospective vendor or a related party to the vendor or prospective vendor is a debtor and: (1) the debt owed is an amount greater than one thousand dollars in the aggregate; or (2) the debtor is in employer default.

EXCEPTION: The prohibition listed above does not apply where a vendor has contested any tax administered pursuant to chapter eleven of the W. Va. Code, workers' compensation premium, permit fee or environmental fee or assessment and the matter has not become final or where the vendor has entered into a payment plan or agreement and the vendor is not in default of any of the provisions of such plan or agreement.

DEFINITIONS:

"Debt" means any assessment, premium, penalty, fine, tax or other amount of money owed to the state or any of its political subdivisions because of a judgment, fine, permit violation, license assessment, defaulted workers' compensation premium, penalty or other assessment presently delinquent or due and required to be paid to the state or any of its political subdivisions, including any interest or additional penalties accrued thereon.

"Employer default" means having an outstanding balance or liability to the old fund or to the uninsured employers' fund or being in policy default, as defined in W. Va. Code § 23-2c-2, failure to maintain mandatory workers' compensation coverage, or failure to fully meet its obligations as a workers' compensation self-insured employer. An employer is not in employer default if it has entered into a repayment agreement with the Insurance Commissioner and remains in compliance with the obligations under the repayment agreement.

"Related party" means a party, whether an individual, corporation, partnership, association, limited liability company or any other form or business association or other entity whatsoever, related to any vendor by blood, marriage, ownership or contract through which the party has a relationship of ownership or other interest with the vendor so that the party will actually or by effect receive or control a portion of the benefit, profit or other consideration from performance of a vendor contract with the party receiving an amount that meets or exceeds five percent of the total contract amount.

AFFIRMATION: By signing this form, the vendor's authorized signer affirms and acknowledges under penalty of law for false swearing (W. Va. Code §81-5-3) that: (1) for construction contracts, the vendor is not in default on any monetary obligation owed to the state or a political subdivision of the state, and (2) for all other contracts, that neither vendor nor any related party owe a debt as defined above and that neither vendor nor any related party are in employer default as defined above, unless the debt or employer default is permitted under the exception above.

WITNESS THE FOLLOWING SIGNATURE:

Vendor's Name: Martins Peterbilt

Authorized Signature: [Signature] Date: 4-5-19

State of West Virginia

County of Cabell, to-wit:

Taken, subscribed, and sworn to before me this 5 day of April, 2019

My Commission expires September 15, 2019

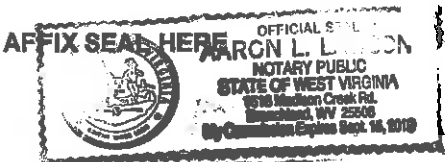

NOTARY PUBLIC [Signature]
Purchasing Affidavit (Revised 01/19/2018)

MEMORANDUM FOR VENDORS DOING BUSINESS WITH THE STATE OF WEST VIRGINIA

Warning: The solicitation will come to the vendor via e-mail marked notification@wvoasis.gov **WVOASISMAIL: SOLICITATION** Make sure this does not end up in your "spam" box, junk mail or some other place your company may have set up to filter your e-mails.

BID SUBMITTAL:

Solicitations out for bid can be viewed by going to wvoasis.gov, click on Vendor Self Service (on the right), then click on Public Access (on the bottom left). Once the site has loaded, the solicitations are on the left-hand side providing the commodity or service and the solicitation number (*Example: CRFQ: ABC1700000001*). To the right is the closing date and time, and the time remaining to submit a bid. If you know the solicitation number you can place it in the Keyword Search (Example: *ABC1700000001*) to go straight to the solicitation.

The screenshot shows the West Virginia Purchasing Bulletin website. At the top, there are navigation links: Home, Help, Accessible Help, Site Map, Privacy Report, and Login. Below the navigation is a header with 'West Virginia Purchasing Bulletin' and tabs for 'Supplies Auctions' and 'Purchase History'. A 'Welcome, New!' message is on the left. The main content area is titled 'Search for Solicitations' and includes a 'Show Me...' dropdown menu with options: All Solicitations, Open Solicitations, Closing Soon, Recently Published, Report Amendments, and Report Awards. Below this is a 'Keyword Search' field with a 'Go' button and an 'Advanced Search' link. The main table lists four solicitations:

Solicitation	Agency/Entity/Buyer/Category	Date	Status
B.86 Trans Control Board ARFQ : GSD150000167 Summary Details	West Virginia West Virginia Agency Request for Quote(ARFQ)	Published On : 4/1/15 Amended On : Closing On : 4/27/15 7:00 PM EDT Time Left : 02:18:34 Intent Posted On :	Open
Kodak i3450 Document Scanner for WV State Tax Dept REV ARFQ : TAX150000008 Summary Details	West Virginia West Virginia Agency Request for Quote(ARFQ)	Published On : 3/20/15 Amended On : Closing On : 4/27/15 2:00 PM EDT Time Left : 02:59:59 Intent Posted On :	Open
Armstrong Hot Water Pump ARFQ : GSD150000166 Summary Details	West Virginia West Virginia Agency Request for Quote(ARFQ)	Published On : 4/1/15 Amended On : Closing On : 4/1/15 4:30 PM EDT Time Left : 03:53:48 Intent Posted On :	Open
ARQS for Supplies for Fargo HDP 5600 Dual Sided Printer ARFQ : LAB150000007 Summary Details	West Virginia West Virginia Agency Request for Quote(ARFQ)	Published On : 3/20/15 Amended On : 3/27/15 Closing On : 4/3/15 4:00 PM EDT Time Left : 04:59:59 Intent Posted On :	Open

Find the solicitation and click on Details, there you will need to click on attachments to find the specifications, terms and conditions, etc.

**MEMORANDUM FOR VENDORS DOING BUSINESS
WITH THE STATE OF WEST VIRGINIA**

In order to submit an electronic bid, Vendors must register in VSS (Vendor Self Service). When prompted, you may select "pay later" to allow the submission of electronic bids. However, the vendor of the winning bid with an aggregate awards amount exceeding \$2,500.00 must pay a \$125 vendor registration fee either by completing the application in VSS and paying via credit card, calling 304-558-2311 with credit card information, or mailing a check to:

Vendor Registration Section
WV Purchasing Division
2019 Washington Street, East
Charleston, WV 25305.

Vendors can also submit paper bids to:

Department of Administration
Purchasing Division
2019 Washington Street, East
Charleston, WV 25305-0130.

On the outside of the envelope, please note the solicitation number, closing date and time, along with the vendor's name and address.
Or you can fax to: 304.558.3970.

NOTE: Please return with your bid, a signed hard copy of the bid, addendum acknowledgment forms if any, completed Purchasing Affidavit, Resident Vendor Preference, relevant supporting documents and any designated bonds that is mandated by the Terms and Conditions.

VENDOR REGISTRATION:

The following is optional, not required, when submitting bids. However, Vendors who have received Notice of Apparent Bid Award are required to meet the following:

To conduct business in this state, according to West Virginia Legislative Rule 148 CSR1.6.1.7 the WV Department of Education must verify Vendor registration status with the West Virginia Purchasing Division, West Virginia Secretary of State's Office (WVSOS) and West Virginia Tax Department (WVTD). The West Virginia Department of Education is prohibited from issuing a purchase order to any vendor until Vendor compliance can be verified that it has been properly registered with:

1. The Purchasing Division

As stated above, the fee is \$125 annually and can be paid with a credit card when registering in VSS. Otherwise, you may complete a WV-1 form and submit

**MEMORANDUM FOR VENDORS DOING BUSINESS
WITH THE STATE OF WEST VIRGINIA**

with a check to: WV Purchasing Division.

<http://www.state.wv.us/admin/purchase/forms.html>

2. The Secretary of State's Office

Registration with the WV Secretary of State's Office is required for all Vendors doing business with the State of West Virginia and may incur a fee of \$100.00 depending on the business registration category.

Business registration with the Secretary of State falls into one of Two (2) categories:

- a. Domestic (formed in West Virginia), or
- b. Foreign (formed out-of- state)

Vendors may complete an Application for Exemption from Certificate of Authority with the WVSOS if you feel your company qualifies. Please mail the completed form and include a check for \$25.00, made payable to WVSOS, along with a copy of the company's home state issued Certificate of Good Standing / Certificate of Corporation.

<http://www.sos.wv.gov/business-licensing/forms/Documents/Corporation/cf-2.pdf>

NOTE: You may also contact the WV Secretary of State's Office with your questions @ 304-558-8000

3. The WV Tax Department

All entities doing business in the State of West Virginia must be registered with WVTAX and pay a one-time fee of \$30.00.

An exemption with WV Secretary of State does not mean you are exempt from registering with the WV Tax Department.

If you need to speak to someone at the West Virginia Tax Department, please call 304-558-8693.

NOTE:

**MEMORANDUM FOR VENDORS DOING BUSINESS
WITH THE STATE OF WEST VIRGINIA**

If you are using the Business4WV website to register with the WV Secretary of State and the WV Tax Department simultaneously, you may do it on-line at <http://www.business4wv.com>. Please note there is a one-time fee of \$130.00.



Purchasing Division
 2019 Washington Street East
 Post Office Box 50130
 Charleston, WV 25305-0130

State of West Virginia
 Request for Quotation
 36 - Vehicles

Proc Folder: 558049

Doc Description: 2018 or Newer, Class 8 Extended Day Cab Tandem Tractor

Proc Type: Central Purchase Order

Date Issued	Solicitation Closes	Solicitation No	Version
2019-03-22	2019-04-05 13:30:00	CRFQ 0214 SUR1900000005	1

BID RECEIVING LOCATION
 BID CLERK
 DEPARTMENT OF ADMINISTRATION
 PURCHASING DIVISION
 2019 WASHINGTON ST E
 CHARLESTON WV 25305
 US

VENDOR
 Vendor Name, Address and Telephone Number:
 Martin's Peterbilt
 715 Orchard Park Rd
 Hurricane WV 25526
 (304) 562-7999

FOR INFORMATION CONTACT THE BUYER
 Melissa Pettrey
 (304) 558-0094
 melissa.k.pettrey@wv.gov

Signature X  FEIN # 32-0029702 DATE 4-5-19

All offers subject to all terms and conditions contained in this solicitation

ADDITIONAL INFORMATION:

Central Request for Quotation

The West Virginia Purchasing Division is soliciting bids on behalf of the West Virginia State Agency for Surplus Property to establish a Contract for the One-Time Purchase of a 2018 or newer, Class 8 Extended Day Cab Tandem Tractor per the bid requirements, specifications, terms and conditions attached to this solicitation.

INVOICE TO		SHIP TO	
ADMINISTRATIVE SERVICES MANAGER DEPARTMENT OF ADMINISTRATION SURPLUS PROPERTY 2700 CHARLES AVE DUNBAR WV25064-2236 US		ADMINISTRATIVE SERVICES MANAGER DEPARTMENT OF ADMINISTRATION SURPLUS PROPERTY 2700 CHARLES AVE DUNBAR WV 25064 US	

Line	Comm Ln Desc	Qty	Unit Issue	Unit Price	Total Price
1	2018 or Newer Class 8 Tandem Axle Truck Tractor	1.00000	EA		

Comm Code	Manufacturer	Specification	Model #
25102100	<i>Peterbilt</i>	<i>Extended Day-Cab Tractor</i>	<i>389</i>

Extended Description :

2018 or Newer, Class 8 Extended Day Cab Tandem Tractor per specifications

SUR1900000005	Document Phase Final	Document Description 2018 or Newer, Class 8 Extended Day Cab Tandem Tractor	Page 3 of 3
----------------------	--------------------------------	--	------------------------------

ADDITIONAL TERMS AND CONDITIONS

See attached document(s) for additional Terms and Conditions

Martin's Peterbilt
715 Orchard Park Road
Hurricane W.V. 257526
OFFICE (304)562-7999 FAX (855)849-7470

April 5, 2019

State Of West Virginia
Department of Administration
Purchasing Division
2019 Washington Street, East
Charleston, West Virginia 25305-0130

Attn: Mr. Allen McVey
Attn: Mr. W. Michael Sheets

Dear Gentleman:

Enclosed you will please find Martin's Peterbilt quotation on four (1) 2020 Peterbilt 389 Extended Day-Cab Tractor. You will find the specifications and pricing included.

Included in the Price of the Truck is New Unit Service and delivery of the 2020 389 Peterbilt Extended Day-Cab Tractor.

Delivery time for the Peterbilt 389 Extended Day-Cab Tractor will approximately be sometime in August 2019. Quote is valid for fifteen days; this quoted price does not include county, state or federal taxes.

Martin's Peterbilt wishes to thank you for this opportunity to earn your business and looks forward to serving your trucking needs. Should you have any questions pertaining to the attachment, please feel free to contact me at (304)-562-7999.

Thank You

Aaron Lawson, LD Wright, JB Burns



Martin's Peterbilt

Not Exact Spec
Sample Photo





Not Exact Spec
Sample Photo



Not Exact Spec
Sample Photo



Martin's Peterbilt M300
174 Old Whitley Rd

389/44/40/15

London, Kentucky United States 40741

Phone: (606) 878-6410

Fax: (606) 878-2800

Email:

Phone:

Fax:

Contact Email:

Prepared for: Default Contact

Vehicle Summary Image Report

Model 389	List Price	\$209,913	Weight	16580
Engine	PACCAR MX-13 510@1800 GV@2200 1850@1000			
Front Axle	Meritor MFS-12E 12,500 lb, 3.5 m Drop			
Front Tires	FF MN 16ply 275/80R24.5 Xline Energy Z			
Rear Axle	Meritor MT40-14X 40,000 lb			
Rear Tires	RR MN 16ply 275/80R24.5 Xline Energy Z			
RrAxle Ratio	Ratio 3.08 Rear Axle			
Suspension	Peterbilt Low Air Leaf 40,000lb, 52in Ax			
Transmission	Eaton RTL018918B 18-Speed			
Quote/DTPO/CO Number: C1040010				

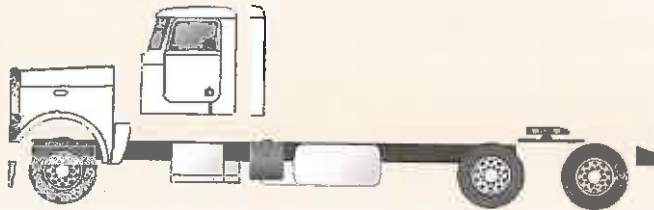

Unpublished options may require review/approval.
Dimensional and performance data for unpublished options may vary from that displayed in PROSPECTOR.

Printed: 4/5/2019 10:15:26 AM
Effective Date: Jul 1, 2018
Prepared by: ID: ldwright

Complete

Model Number: Model 389
Quote/DTPO/CO: C1040010
Version Number: 37.00

Martin's Peterbilt M300
174 Old Whitley Rd

389/44/40/15

London, Kentucky United States 40741
Phone: (606) 878-6410
Fax: (606) 878-2800
Email:

Phone:
Fax:
Contact Email:
Prepared for: Default Contact

Vehicle Summary

	Unit		Chassis	
Model:		Model 389	Fr Axle Load (lbs):	12000
Type:		Tractor	Rr Axle Load (lbs)	40000
Description:		WW STATE BID	G.C.W. (lbs):	80000
	Application		Road Conditions:	
Intended Serv.:		General Freight	Class A (Highway)	100
Commodity:		Other Commodity	Class B (Hwy/Mtn)	0
	Body		Class C (Off-Hwy)	0
Type:			Class D (Off-Road)	0
Length (ft):		0	Maximum Grade:	6
Height (ft):		0.0	Wheelbase (in):	240
Max Laden Weight (lbs):		0	Overhang (in):	57
	Trailer		Fr Axle to BOC (in):	92.8
No. of Trailer Axles:		3	Cab to Axle (in):	147.2
Type:		Flatbed	Cab to EOF (in):	204.2
Length (ft):		38	Overall Comb. Length	695
Height (ft):		13.5	(in):	
Kingpin Inset (in):		36		
Corner Radius (in):		2		
	Restrictions		Special Req.	
Length (ft):		65	United States Registry	
Width (in):		102		
Height (ft):		13.5		

Approved by: _____

Date: _____

Note: All sales are F.O.B. designated plant of manufacture.

	Ask your dealer for a quote today, or visit our website @ www.paccarfinancial.com .
	PACCAR Financial offers innovative finance, lease and insurance programs customized to meet your needs.

Unpublished options may require review/approval.
Dimensional and performance data for unpublished options may vary from that displayed in PROSPECTOR.

Printed:	4/5/2019 10:15:07 AM	Complete	Model Number:	Model 389
Effective Date:	Jul 1, 2018		Quote/DTPO/CO:	C1040010
Prepared by:	ID: ldwright		Version Number:	37.00



Martin's Peterbilt M300
174 Old Whitley Rd

389/44/40/15

London, Kentucky United States 40741

Phone: (606) 878-6410

Fax: (606) 878-2800

Email:

Phone:

Fax:

Contact Email:

Prepared for: Default Contact

	Description	\$ List	Weight
Base Model			
	Model 389 The Model 389 embodies the Peterbilt heritage and merges it with a proven design to create a legendary classic for vocational applications. The lightweight, all-aluminum cab with lap seam construction, aircraft grade fasteners and bulkhead style doors is legendary for its durability. The pod-mounted headlamps are durable, corrosion-resistant and cost-effective to replace. Peterbilt's all-aluminum cab is not only extremely durable, it's also lightweight to allow for increased payloads to maximize performance and profitability.	184,235	14,915
	Other Commodity	0	0
	General Freight Truck or tractor used in over-the-road hauling of general freight. Pickup to delivery distance is typically over 100 miles and annual mileage is typically over 60,000 miles per year. Operation is typically on-highway.	0	0
	Flatbed	0	0
	United States Registry	0	0
Configuration			
	Not Applicable Secondary Manufacturer	0	0
Frame & Equipment			
	10-5/8in Steel Rails 286-325 in 10.625 x 3.45 x .313 Dimension, 1,776,000 RBM; Yield Strength: 120,000 psi. Section Modulus: 14.8 cubic inches. Weight: 1.44 lbs/inch pair	47	122
	FRAME RAKE EXCEEDS RECOMMENDED	0	0
	EOF Tractor Tapered with Xmbr Includes Kingpin Cutout	0	0
	Peterbilt Rear Mudflaps, Painted Premium Hangers Painted black regardless of frame color. Requires two additional inches of overhang for tractors.	51	36
	Holland FW35 Fifth Wheel Top Plate	2,007	240
	Fifth Wheel Setting Behind C/L Bogie 4in Fifth wheel setting 4" behind bogie	0	0
	LH Fifth Wheel Release	0	0
	8.6in - 9.25in Fifth Wheel Height	0	99
	Holland Lightweight Air Slide Not available with suspensions > 40k.	0	0
	12in Air Slide For Fifth Wheel	0	154

Unpublished options may require review/approval.

Dimensional and performance data for unpublished options may vary from that displayed in PROSPECTOR.

Printed:

4/5/2019 10:15:07 AM

Complete

Model Number:

Model 389



Description	\$ List	Weight
Locate Frame Access Steps As Far Forward As Possible	0	0
Frame Mounted Deck Plate and Access Pkg, LH Side	437	41
Front Axle & Equipment		
Meritor MFS+12E 12,500 lb, 3.5 in. Drop Axle is designed for applications with a gross axle weight rating (GAWR) of 13,000 pounds. Axles include special low-friction bushings, double draw keys and integral thrust bearing and seal design for durability, low maintenance and ease of service.	0	0
FRONT AXLE APPROVED	0	0
Taper Leaf Springs, Shocks 12,000 lb	0	0
Power Steering Sheppard M100 For use with 10,000 to 13,200 lb. axle ratings. Glidekote splines on steering shaft extend service life of components.	0	0
Power Steering Reservoir Frame Mounted	0	0
PHP10 Iron PreSet PLUS Hubs	-833	-113
Greasable Front Spring Pins	44	0
Bendix Air Cam Front HP Drum Brakes 16.5x5 Complies with reduced stopping distance regulations. For use with 10,000-13,200 lb steer axles, up to and including 40,000 lb drive axles and up to 20,000 lb lift axles. Includes high performance drum brakes, automatic slack adjusters, outboard mounted brake drums.	338	-25
Meritor Wide Track IPO Standard, Front Axle MFS+ 3.5" Drop / MFS 3.74" Drop. 71in KPI IPO 69in with MFS and MFS+ axles For improved turning radius.	0	5
Long Stroke Brakes, Front Axle	21	0
70 MM FRONT SPRING SPACER BLOCKS	0	0
Gusseted Cam Brackets, Steer Axle	25	0
Heavy Duty Cam Bushings, Steer Axle	28	0
Rear Axle & Equipment		
Meritor MT40-14X 40,000 lb Interaxle diff lock air rocker occupies space of one gauge. Laser factory axle alignment to improve handling & reduce tire wear. Magnetic rear axle oil drain plug captures & holds any metal fragments in drive axle lube to extend service life. Parking brakes on all drive axles for optimal performance. Cognis EMGARD® FE 75W-90 synthetic axle lube provides over 1% fuel economy improvement. Reduces wear & extends maintenance intervals, resulting in increased uptime. Provides improved fluid flow to protect components in extreme cold conditions & withstand the stress from high temperatures, extending component life.	190	174
REAR AXLE APPROVED	0	0
PHP10 Iron PreSet PLUS Hubs	-44	0
Long Stroke Parking Brakes, Drive Axle(s)	0	0
Separate Dash Controls, Cont Trac Full Lock Dana Spicer or Meritor - Tandem or TriDrive Axles (Air Rocker Switch occupies the space of two gauges for tandem axle and three gauges for tri-drive axle)	93	2
Unpublished options may require review/approval. Dimensional and performance data for unpublished options may vary from that displayed in PROSPECTOR.		



Description	\$ List	Weight
Bendix ESP Electronic Stability Program With ATC Tractor service only. The Bendix ESP system is designed to continuously monitor a variety of vehicle parameters and sensors to determine if the vehicle is reaching a critical stability threshold. If such a situation develops, the system will quickly and automatically intervene to assist the driver by selectively applying tractor and trailer brakes, and de-throttling the engine.	0	0
Gusseted Cam Brackets, Drive Axle(s)	65	2
Anti-Lock Braking System (ABS) 6S6M ABS-6. Includes air braking system.	0	0
Synthetic Axle Lubricant All Axles Peterbilt heavy duty models include Fuel Efficient Cognis EMGARD FE75W-90 which provides customers performance advantages over current synthetic lubricants with reduced gear wear and extended maintenance intervals, resulting in increased uptime. In addition, the lubricant provides improved fluid flow to protect gears in extreme cold conditions and withstand the stress from high temperatures, extending component life.	0	0
Bendix Air Cam Rear Drum Brakes 16.5x7 Includes Automatic Slack Adjusters & Outboard Mounted Brake Drums.	0	0
Diff Lock Tandem Axles With Speed Interlock. Automatically Disengages Wheel Diff Lock at Speeds Above 25 mph.	1,824	60
Heavy Duty Cam Bushings, Drive Axle(s)	55	0
Ratio 3.08 Rear Axle	0	0
Peterbilt Low Air Leaf 40,000lb,52in Axle Spacing Light Weight	536	-59
Dash Mtd Dump Switch With Indicator Light For suspension	42	2

Engine & Equipment

PACCAR MX-13 510@1600 GV@2200 1850@1000 Performance (2017 Emissions)	1,858	0
N20690 N162 75....Maximum Accelerator Pedal Ve		
N20700 N006 64....Max Cruise Speed (N006)		
N20710 N052 650....Idle Target (N052)		
N20740 N015 NO....Enable MX Retarder in Neutra		
N20750 N019 0.....Delay in Engine Brake Activa		
N20760 N014 2.....Auto Retard Vehicle Speed Of		
N20770 N013 4.....Downhill Speed Limiter Vehic		
N20780 N001 16....Minimum Speed to Turn Cruise		
N20790 N003 19....Minimum Cruise Control Speed		
N20800 N002 19....Min Speed to Automatically T		
N20830 N039 OFF...Allow Multi-Torque Only When		
N20840 N187 5.....Timer Setting Non-PTO Mode w		
N20850 N188 5.....Timer Setting Non-PTO Mode w		
N20860 N185 40....Low Ambient Temperature Over		
N20870 N184 80....High Ambient Temperature Ove		
N20900 N186 5.....Timer Setting When in PTO Mo		
N20910 N190 YES...Reset EIST Timer Based on En		
N20930 N071 ON....FIC Enable/Disable (N071)		
N20940 N072 1900..Maximum Fast Idle Control En		
N20990 N078 ON....PTO Mode Disabled w/ Clutch		
N21000 N101 ON....PTO Mode Disabled w/ Service		
N21010 N079 ON....PTO Mode Enable Only w/ Park		
N21020 N080 1.....PTO Vehicle Speed Limit (N08		

Unpublished options may require review/approval.

Dimensional and performance data for unpublished options may vary from that displayed in PROSPECTOR.

Printed:	4/5/2019 10:15:07 AM	Complete	Model Number:	Model 389
Effective Date:	Jul 1, 2018		Quote/DTPO/CO:	C1040010
Prepared by:	ID:ldwright		Version Number:	37.00



Description	\$ List	Weight
N21100 N087 780...RPM Set Point (N087)		
N21110 N086 2000..Maximum Engine Speed During		
N21160 N110 1.....Enable Set Point w/ Set/Acce		
N21170 N191 NO....Override EIST Timer Based on		
N21190 N193 0.....Expiration Distance (N193)		
N21230 N197 YES...Enable Accelerator Pedal Res		
N21240 N198 YES...Enable Service Brake Reset (
N21250 N199 YES...Enable Clutch Pedal Reset (N		
N21260 N200 YES...Allow EIST Timer Overrides i		
N21280 N163 0.....Maximum Cycle Distance (N163)		
N21300 N169 0.....Expiration Distance (N169)		
N21310 N170 75....Standard Maximum Speed Limit		
N21320 N106 650...Minimum Engine Speed During		
N21640 N179 YES...Enable Park Brake Reset (N17		
N21650 N173 0.....Reserve Speed Offset (N173)		
N21670 N164 252...Reserve Speed Function Reset		
N21900 N073 0.....Cab Accel Pedal Type in PTO		
N21910 N182 30....Coolant Temperature Override		
N21920 N219 3.....Offset mode (N219)		
N21930 N224 0.....Maximum Vehicle Speed Bonus		
N21940 N227 -2....Maximum Vehicle Speed Penalt		
N21950 N246 4.....Minimum Vehicle Speed for DS		
N21960 N247 1.....Lowest Gear that DSA will be		
N21970 N248 10....Highest Gear that DSA will b		
N21980 N076 2000..Max Accelerator Controlled E		
N21990 N307 OFF...Cab Accelerator Active in Re		
Engine Idle Shutdown Timer Enabled	0	0
Enable EIST Ambient Temp Override	0	0
Eff EIST NA Expiration Miles	0	0
Effective VSL Setting 65.0 MPH or Greater (USA)	0	0
Typical Operating Speed 70 MPH	0	0
MX Retarder State Cruise Control On (Manual Mode Engine Parameter)	0	0
Powertrain Optimized for Fuel Economy Best analysis for vehicles which operate at or near cruise speed 90 plus percent of time.	0	0
Enable MX Retarder Auto Retard (Engine Parameter)	0	0
Engine Monitoring Protection - Derate (PACCAR MX) A warning is provided in the A-Panel display when DPF regeneration is required. Continued operation without regeneration will initiate automate derating of the engine's power and can result in damage to the engine.	0	0
CARB Engine Idling Compliance PACCAR PX-7, PX-9 and MX, Cummins ISL, ISM and ISX diesel engines will include the required factory installed serialized sticker on the drivers door to identify them as meeting the NOx idling standard.	0	0
Omit Chevron Engine Oil Sticker (DELO)	-4	0
PACCAR 160 Amp Alternator, Brushed	0	0
Immersion Type Block Heater 110-120V	0	0

Standard location is center left hand under cab and includes a weather-proof cover that protects the receptacle. This pre-heater keeps the coolant in the engine block from freezing when the engine is not running.

Unpublished options may require review/approval.

Dimensional and performance data for unpublished options may vary from that displayed in PROSPECTOR.

Printed:	4/5/2019 10:15:07 AM	Complete	Model Number:	Model 389
Effective Date:	Jul 1, 2018		Quote/DTPO/CO:	C1040010
Prepared by:	ID: ldwright		Version Number:	37.00



Description	\$ List	Weight
Oil Pan Heater 120V/300W Operates via 120V ShorePower System and keeps the oil warm when the engine is not running. This option utilizes the same receptacle as the immersion pre-heater if specified together.	128	2
PACCAR Premium Starter-MX Engines Only PACCAR Premium 12 volt. Better cranking power, lower current draw and improved warranty to 5-yr/500K miles.	0	0
3 PACCAR Premium 12V Dual Purpose Batt 2190 CCA Threaded stud type terminal. Stranded copper battery cables are double aught (00) or larger to reduce resistance.	0	0
DM Advantage ON/OFF Fan Clutch	0	0
Wabco 25.9 CFM Air Compressor, MX only	0	0
Compression Brake, MX	0	0
PACCAR Fuel/Water Separator Standard Service Interval	0	0
No Fluid Heat Option for Fuel Filter	0	0
No Electric Heat Option for Fuel Filter	0	0
High Efficiency Cooling System Cooling module is a combination of steel and aluminum components, with aluminum connections to maximize performance and cooling capability. Silicone radiator & heater hoses enhance value, durability, & reliability. Constant tension band clamps reduce leaks. ClimaTech extended life coolant extends maintenance intervals which reduces maintenance costs. Anti-freeze effective to -30 degrees F helps protect the engine. Low coolant level sensor warns of low coolant condition to prevent engine damage. Radiator Size by Model: 587: 1330 sq in, 579/367 FEPTO 1325 sq in, 567/365/367: 1440 sq in, 384/386: 1301 sq in, 365 FEPTO: 1184 sq in, 389/367 HH: 1669 sq in, 348: 1000 sq in, 320: 1242 sq in.	0	0
(2) 15in SS Air Cleaners, Cowl Mtd, SS Caps Stainless steel grill, integral R-Gard	1,288	59
Exhaust Dual Side Of Cab, LH Side of Cab Stack Aesthetic Only, DPF/SCR RH Under Cab (2017)	2,382	110
Curved Tip Standpipe(s)	50	0
48in Ht, 5in Dia Chrome, Clear Coat Standpipe(s)	156	8
Transmission & Equipment		
Eaton RTLO18918B 18-Speed Includes oil-to-water cooler, rear transmission support, direct shift pattern. Synthetic lubricant to reduce friction, improve efficiency, & extend component life. Magnetic transmission oil drain plug captures & holds any metal fragments in transmission oil to extend service life. Torque limiting clutch brake. Forward Ratios: LL-14.4, L-12.29, 1st-8.51, 2nd-7.26, 14th-1.00, 15th-0.86, 16th-.073 / Reverse Ratios: R1-15.06, R2-12.85, R3-4.03, R4-3.43	3,041	120
RPL20 Driveline Interaxle	0	0
RPL25 SD Driveline, 1 Midship Bearing	903	115

DRIVELINE APPROVED

0 0

Manual Shifter, Black

0 0

Unpublished options may require review/approval.
Dimensional and performance data for unpublished options may vary from that displayed in PROSPECTOR.

Printed:	4/5/2019 10:15:07 AM	Complete	Model Number:	Model 389
Effective Date:	Jul 1, 2018		Quote/DTPO/CO:	C1040010
Prepared by:	ID: ldwright		Version Number:	37.00



Description	\$ List	Weight
Heavy Duty Input Bearing For PTO Operation For use with Fuller RTLO Transmission 1100 through 2250 Series. The roller style input shaft bearing has twice the dynamic radial load capability of the ball bearing style and is recommended for transmissions that will be equipped with a transmission mounted 6 or 8 bolt PTO.	36	0
Air & Trailer Equipment		
Bendix AD-IS Air Dryer W/Heater And Coalescing Filter	0	0
Pull Cords All Air Tanks	6	0
Nylon Chassis Hose	0	0
Steel Painted Air Tanks All air tanks are steel with painted finish except when Code 4543330 Polish Aluminum Air Tanks is also selected (then exposed air tanks outside the frame rails will be polished aluminum). Peterbilt will determine the optimal size and location of required air tanks. Narratives requesting a specific air tank size or location will not be accepted for factory installation. See ECAT to determine number or location of air tanks installed.	0	0
Chroming of Hose Tenna	32	0
Trailer Hand Valve With Column-Mounted Controls	0	0
A&E Connections BOC/BOS with Hose Tenna	0	0
12ft A&E Lines Straight & Two 7-way Plugs	108	8
Locate A&E Connections 41in-54in BOC/BOS	0	0
Tires & Wheels		
FF: MN 16ply 275/80R24.5 Xline Energy Z	273	8
RR: MN 16ply 275/80R24.5 Xline Energy Z	1,092	36
Code-rear Tire Qty 08	0	0
FF: Alcoa 985657 24.5X8.25 Clean Buff Finish Aluminum, severe service.	546	-10
RR: Alcoa 985657 24.5X8.25 Clean Buff Aluminum, severe service.	2,184	-40
Code-rear Rim Qty 08	0	0
Fuel Tanks		
26 in Aluminum 150 Gallon Fuel Tank RH BOC Paddle handle filler cap with threadless filler neck. Top draw fuel plumbing reduces chance of introducing air into the fuel system during low fuel level conditions due to the central placement of fuel pickup tube. Wire braid fuel lines increase durability & reduce potential for leaks.	152	42
26 in Aluminum 110 Gallon Fuel Tank LH BOC Paddle handle filler cap with threadless filler neck. Top draw fuel plumbing reduces chance of introducing air into the fuel system during low fuel level conditions due to the central placement of fuel pickup tube. Wire braid fuel lines increase durability & reduce potential for leaks.	96	11
Location RH BOC 150 Gallon	0	0

Location LH BOC 110 Gallon	0	0
Fuel Tank Fill Rear Not available on under cab fuel tanks.	0	0
Split Aluminum Fuel Tank RH BOC	278	4

Unpublished options may require review/approval.
Dimensional and performance data for unpublished options may vary from that displayed in PROSPECTOR.

Printed: 4/5/2019 10:15:07 AM Complete Model Number: Model 389
 Effective Date: Jul 1, 2018 Quote/DTPO/CO: C1040010
 Prepared by: ID: ldwright Version Number: 37.00



Description	\$ List	Weight
Polish (2) Aluminum Fuel Tanks	488	0
(4) Straps Per Tank, (2) Tanks Subject to frame review.	1,362	101
Fuel Rear In Split Tank	0	0
90 Gallon Fuel In Split Tank	0	0
Polish All Fuel / Hydraulic Tank Straps Does not apply to Rectangular Def Tank straps.	91	0
DEF Tank Mounted LH BOC Models 220 and 520 mounted LH cab fender	0	0
Standard DEF To Fuel Ratio 2:1 Or Greater	0	0
Polished Stainless Steel Cover For DEF Tank	231	0
Mount DEF Tank Rearward Of Fuel Tank	0	0
DEF Tank Medium	77	22

Battery Box & Bumper

Aluminum Battery Box LH Under Cab, Non-Slip Step Includes diamond pattern block shaped cover in traditional/vocational models and a smooth finish tapered cover on aerodynamic models.	0	0
Aftertreatment RH U/C ALUMINUM Non-Slip Cab Entry Step. DPF/SCR for diesel engines, catalyst for natural gas engines. On Models 579 specifying chassis fairings, the box will be aerodynamic.	0	0
Steel Bumper Deep Tapered Chromed Two tow pins.	0	0

Cab & Equipment

Alum Cab 123in BBC Alum Hood SFFA fenders w/polished crown, spring tilt assist. Proprietary anti-blow-down locking mechanism that keeps hood open during servicing & prevents unintentional closing. Hood latch each side secures hood to cowl. Proprietary all-alum cab is light weight & durable for long service life. One-piece roof reduces potential for leaks. Two-piece windshield for cost effective windshield replacement. Lap seam construction & aircraft fasteners has greater clamp load than rivets. Bulkhead style doors provide virtually water-tight, rattle-free performance. Extruded alum door frames for strength & durability. Full length, heavy-duty piano-type stainless steel door hinges & pins provide durability. View window in RH door for safety. Electric windshield wipers & washers w/intermittent wiper function. Grab handles mtd on cab LH & RH for cab access. Convex mirror over RH door & below each rear view mirror for improved visibility & safety.	0	0
Thermal Insulation Package in Cab Includes thick, closed-cell foam in floor, special mylar-faced foam in walls and roof structure.	20	2
10 Inch Extension for Ultra Day Cab	4,981	163

Add additional 10" to the loadspace dimension-- refer to the horizontal dimension workscreen.

No Sleeper Selected	0	0
Peterbilt UltraRide Driver Seat	0	0
Peterbilt UltraRide Passenger Seat	0	0
Drivers Armrest - RH Only	37	2

Unpublished options may require review/approval.
Dimensional and performance data for unpublished options may vary from that displayed in PROSPECTOR.

Printed:	4/5/2019 10:15:07 AM	Complete	Model Number:	Model 389
Effective Date:	Jul 1, 2018		Quote/DTPO/CO:	C1040010
Prepared by:	ID: ldwright		Version Number:	37.00



Description	\$ List	Weight
Black Seat Color ipo Standard Color	0	0
Air Ride Driver	0	0
High Back Driver	0	0
Vinyl Driver	0	0
Air Ride Passenger	214	43
High Back Passenger	0	0
Vinyl Passenger	0	0
Power Door Locks Both Doors	117	2
Adjustable Steering Column - Tilt/Telescope	448	11
Steering Wheel with Peterbilt Logo Steering Wheel with embossed Peterbilt logo over horn button.	0	0
ProBilt Interior - Arctic Gray Includes rugged charcoal instrument panels, gray dash with glare-resistant, charcoal soft-touch upper, dark gray hard trim, black bezels on gauges, cigar lighter and ashtray with power port, monochromatic dark gray durable doorpads with map pocket on driver's side, dark gray molded back wall, 18 inch 4-spoke soft-touch steering wheel, soft-touch steering column cover, power lift passenger window, extruded rubber floor covering, header-mounted domelight, driver and passenger dome/reading lights, footwell lighting, integrated "dead pedal", (5) inside entry grab handles, (2) inside sunvisors, (2) coat hooks, cup holder and map bin in dash.	0	0
Dark Window Tint ipo STD Tint - Day Cab	22	0
Day Cab Rear Window	0	0
Two Piece Flat Windshield	12	0
Power Lift Windows - Both Doors For use with ProBilt or Prestige Interior	27	0
Combo Fresh Air Heater/Air Conditioner With radiator mounted condenser, dedicated side window defrosters, Bi-Level Heater/Defroster Controls, 54,500 BTU/HR, and silicone heater hoses.	0	0
Peterbilt Comfort Control - Cab	0	0
Outside Sunvisor - Stainless Steel Not available with 2.1M high roof sleeper.	270	4
Mirrors SSTL Each Side Heated and Motorized with Switch on Door. Right Click on option to See Picture in Product Portfolio.	350	2
(2) Convex 8 Inch SS Mirrors Center mounted under mirror bracket. If rear view mirrors are heated, the	0	0

convex mirrors will be heated. Option includes dual door stops.

(2) Air Horns 24.5in Chrome - Round w/Horn Shield	519	8
Standard Speaker Package For Cab (2) Speakers	140	4
ConcertClass Without CD, Includes BT Phone and Audio, AM/FM, WB, USB and MP3.	378	10
Cobra 40 Channel CB Radio w/Integral Speaker Includes illuminated front panel.	251	11
CB Antenna Mounting, LH Mirror Available with Rami only on 1.9m, available without Rami on medium duty	20	0

Unpublished options may require review/approval.

Dimensional and performance data for unpublished options may vary from that displayed in PROSPECTOR.

Printed:	4/5/2019 10:15:07 AM	Complete	Model Number:	Model 389
Effective Date:	Jul 1, 2018		Quote/DTPO/CO:	C1040010
Prepared by:	ID: ldwright		Version Number:	37.00



Description	\$ List	Weight
CB Antenna Mounting, RH Mirror Available with Rami only on 1.9m, available without Rami on medium duty	20	0
RAMI Multiband Antenna System - Dual Includes (2) 48 inch antennas.	139	4
Mount CB Speaker LH Rear Corner Cab Headliner	35	2
SmartLINQ Remote Diagnostics SmartLINQ is Peterbilt's proprietary remote diagnostics service which monitors the engine and aftertreatment for diagnostic codes providing real-time code analysis maximizing vehicle uptime and strengthening the fleets partnership with their dealer. SmartLINQ provides fault coverage for over 800 codes, a customizable email notification for 116 codes plus a web portal to manage your entire fleet included at no additional charge. SmartLINQ is compatible with any telematics system and doesn't require a specific fleet management system. For those whose customers utilize PeopleNet, the pre-wire with remote diagnostics will provide a more integrated solution utilizing the existing SmartLINQ modem. For those whose customers utilize other fleet services products, the existing pre-wire option for the other fleet service devices will continue to be available. SmartLINQ is standard with MX-13 engines and available on the models 587,579,567,389,367 and 365.	0	0
Plug-In Auto Reset Circuit Breaker in place of fuses in junction box.	99	0
Peterbilt Electric Windshield Wipers With Intermittent Feature.	0	0
Triangle Reflector Kit Shipped Loose	18	13
Fire Extinguisher; Cab Mounted Hazmat approved UL listed/rated ABC.	58	8
Backup Alarm (87-112 Decibels) Variable adjusting.	54	6
Main Transmission Temperature Gauge	56	0
Axle Temperature Gauges, Tandem Drive	176	2
Engine Oil Temperature Gauge	46	0
Air Application Gauge	75	0
Air Restriction Indicator Mounted on air cleaner,intake piping, or firewall.	0	0
Disable Brake Light With Engine Brake	0	0
Suspension Pressure Gauge	55	2

Main Instrumentation Panel, Graphics Display	0	0
Includes speedometer with trip odometer, tachometer with hourmeter and outside air temperature display, voltmeter, engine oil pressure, engine coolant temperature, fuel level, primary and secondary air pressure gauges. Includes standard warning light package: high water temperature, low oil pressure, and low air pressure warning lights w/audible alarms, high beam, turn signal, low fuel, parking brake, and ice warning indicators; seat belt reminder; rocker switches with long-life LED indicators; multi-function turn stalk with flash-to-pass feature (night mode flashes headlights and marker lights; day mode flashes headlights only), intermittent windshield wiper and headlamp beam control. Hydraulic braked trucks do not include air pressure gauges.		

Headlights Projector Module Pod	0	0
Integral Turn Signals		

Unpublished options may require review/approval.
Dimensional and performance data for unpublished options may vary from that displayed in PROSPECTOR.

Printed:	4/5/2019 10:15:07 AM	Complete	Model Number:	Model 389
Effective Date:	Jul 1, 2018		Quote/DTPO/CO:	C1040010
Prepared by:	ID: ldwright		Version Number:	37.00



Description	\$ List	Weight
(5) Marker Lights, Aero LED Light Emitting Diodes	0	0
Switch & Wiring F/O Auxiliary Light Under cab/sleeper (15 amp max.). Includes switch on the dash which will power metri-pack sealed connections at the RH/LH side of cab at the base of the firewall.	50	2
Switch & Wiring F/O Aux Light On Air Cleaners Includes switch on the dash which will power metri-pack sealed connections at the RH/LH air cleaner outlets	83	2
Switch & Wiring For F/O Beacon/Strobe 10 ft coiled wire BOC/BOS at rear sill	72	2
LED Stop/Turn/Tail/Backup Bracket mounted LH/RH EOF	20	2
(1) F/O Load Light, Switch & 10ft Wire Coil Under / in cab / sleeper	36	2

Paint

(1) Color Axalta Two Stage - Cab/Hood	0	0
Base Coat/Clear Coat		
N85020 A - 737133EY NAVY BLUE		
N85400 HOOD TOP 737133EY NAVY BLUE		
N85500 CAB ROOF 737133EY NAVY BLUE		
N85200 FRAME L0001EA BLACK		
N85300 FENDER 737133EY NAVY BLUE		
N85720 SK FAIRINGS 737133EY NAVY BLUE		

Options Not Subject To Discount

Peterbilt Class 8 Standard Coverage 1 year/100,000 Miles (160,000 km)	0	0
PACCAR MX Standard Coverage 2 yrs/250,000 mi (400,000 km)/6,250 hrs	0	0

Miscellaneous

Day Cab / ProBilt Interior (DB)	0	0
2017 EPA Emissions Engine Warranty Only	0	0



Martin's Peterbilt M300
174 Old Whitley Rd

389/44/40/15

London, Kentucky United States 40741

Phone: (606) 878-6410

Fax: (606) 878-2800

Email:

Phone:

Fax:

Contact Email:

Prepared for: Default Contact

Horizontal Dimensions

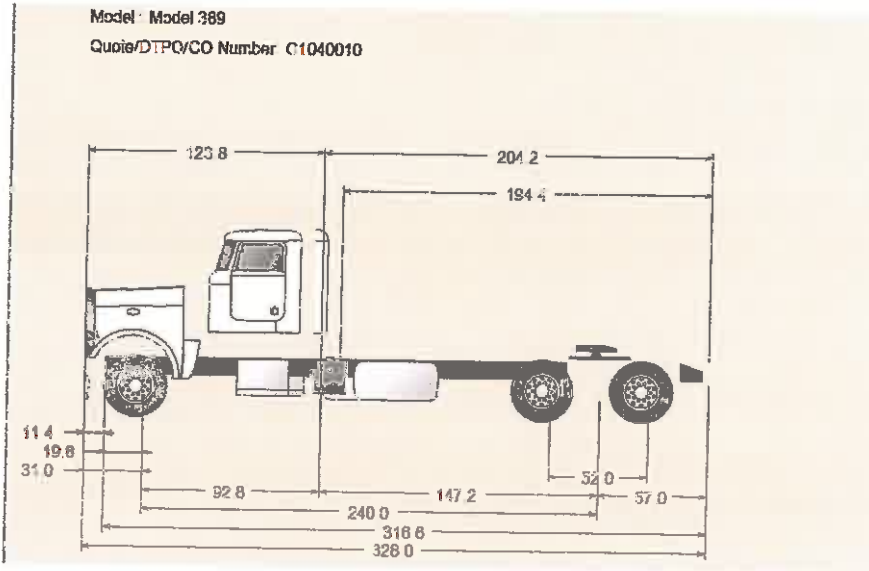

Unpublished options may require review/approval.
Dimensional and performance data for unpublished options may vary from that displayed in PROSPECTOR.

Printed: 4/5/2019 10:15:54 AM
Effective Date: Jul 1, 2018
Prepared by: ID: ldwright

Complete

Model Number: Model 389
Quote/DTPO/CO: C1040010
Version Number: 37.00



Martin's Peterbilt M300
174 Old Whitley Rd

389/44/40/15

London, Kentucky United States 40741

Phone: (606) 878-6410

Fax: (606) 878-2800

Email:

Phone:

Fax:

Contact Email:

Prepared for: Default Contact

Fifth Wheel Height

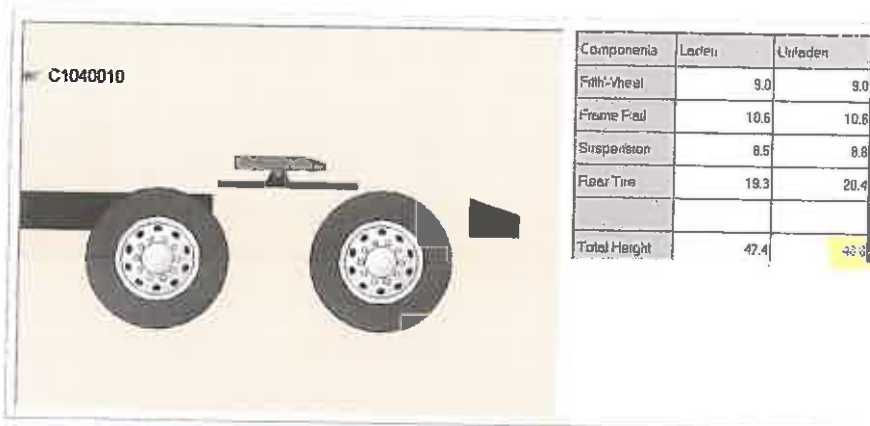

Component	Code	Description
Fifth Wheel:	0835860	Rolland FW35 Fifth Wheel Top Plate
Frame:	0516020	10-5/8in Steel Rails 286-325 in
Suspension:	1021970	Peterbilt Low Air Load 40 000lb 52in Axle Spacing
Tire:	5Y58900	RR MN 16ply 275/80R24.5 Mline Energy Z

Unpublished options may require review/approval.
Dimensional and performance data for unpublished options may vary from that displayed in PROSPECTOR.

Printed: 4/5/2019 10:16:03 AM
Effective Date: Jul 1, 2018
Prepared by: ID: ldwright

Complete

Model Number: Model 389
Quote/DTPO/CO: C1040010
Version Number: 37.00



Martin's Peterbilt M300
174 Old Whitley Rd

389/44/40/15

London, Kentucky United States 40741

Phone: (606) 878-6410

Fax: (606) 878-2800

Email:

Phone:

Fax:

Contact Email:

Prepared for: Default Contact

Frame Rake

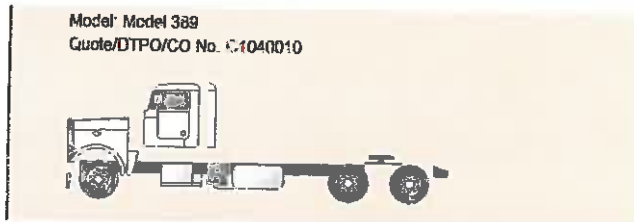

The listed heights should be considered approximations due to variations which may occur in component manufacturing processes, spring set and the way in which the vehicle is loaded.

Component	Code	Name	Laden	Unladen
Frame:	0515020	10-5/8in Steel Rails 286-325 in	10.6	10.6
Front Spring:	1111190	Taper Leaf Springs, Shocks 12,000 lb	8.5	8.9
FX drop-3.5:	1012140	Meritor MFS-12E 12,500 lb, 3.5 in. Drop	0	0
Height adj:	0000800	No Adjustment	0.0	0.0
Front Tires:	5056900	FF: MN 16ply 275/80R24.5 Xline Energy Z	19.3	20.4
Front Frame Height:			38.4	39.9
Frame:	0515020	10-5/8in Steel Rails 286-325 in	10.6	10.6
Suspension:	1821970	Peterbilt Low Air Leaf 40,000lb, 52in Axle Spacing	8.5	8.8
Rear Tires:	5156900	RR: MN 16ply 275/80R24.5 Xline Energy Z	19.3	20.4
Rear Frame Height:			38.4	39.8
Frame Rake:			0	-0.1
Frame Rake Slope (%):			0	0

These characteristics are considered to be out of the standard range:
Laden rake more than 1% of wheelbase from level (positive or negative).

Unpublished options may require review/approval.
Dimensional and performance data for unpublished options may vary from that displayed in PROSPECTOR.

Printed: 4/5/2019 10:16:12 AM
Effective Date: Jul 1, 2018
Prepared by: ID: Idwright

Complete

Model Number: Model 389
Quote/DTPO/CO: C1040010
Version Number: 37.00



Martin's Peterbilt M300
174 Old Whitley Rd

389/44/40/15

London, Kentucky United States 40741

Phone: (606) 878-6410

Fax: (606) 878-2800

Email:

Phone:

Fax:

Contact Email:

Prepared for: Default Contact

Cruise Performance

Configuration: Model 389 / Tractor / Flatbed GCW: 80000
Quote/DIPO/CO Number: C1040010
Aerodynamic Aids: None

Engine: 2072824 PACCAR MX-13 510@1600 GV@2200 1850@1000
Transmission: 4022200 Eaton RTL018918B 18-Speed
Rear Axle: 1526150 Meritor MT40-14X 40,000 lb 3.08 Ratio
Rear Tire: 5156900 RR: MN 16ply 275/80R24.5 Xline Energy Z Revs/Mile: 501

Operating Conditions: 0.7% Rolling Resistance, Engine Fan: Off

Startability:

Transmission Ratio	Maximum Starting Grade (%)
14.40	30.20
12.29	25.30

Engine RPM:	800	900	1000	1100	1200	1300	1400	1500	1600	1700	1800	1900	2000	2100
Gross Torque:	1459	1666	1850	1849	1849	1849	1821	1748	1673	1455	1041	873	724	586
Net Torque:	1321	1517	1692	1693	1695	1697	1673	1606	1538	1336	952	797	659	531
Net HP:	201	260	322	355	387	420	446	459	468	432	326	288	251	212

Gear Ratios: TRN:(1) 14.40 RAX:(1) 3.08

Speed (MPH):	2.2	2.4	2.7	3.0	3.2	3.5	3.8	4.0	4.3	4.6	4.9	5.1	5.4	5.7
Grade (%):	47.6	56.9	66.2	66.3	66.5	66.6	65.2	61.5	57.9	48.3	32.3	26.5	21.6	17.1

Gear Ratios: TRN:(2) 12.29 RAX:(1) 3.08

Speed (MPH):	2.5	2.8	3.2	3.5	3.8	4.1	4.4	4.7	5.1	5.4	5.7	6.0	6.3	6.6
Grade (%):	39.3	46.4	53.3	53.3	53.4	53.5	52.5	49.8	47.2	39.8	27.1	22.3	18.2	14.4

Gear Ratios: TRN:(3) 8.51 RAX:(1) 3.08

Speed (MPH):	3.7	4.1	4.6	5.0	5.5	5.9	6.4	6.9	7.3	7.8	8.2	8.7	9.1	9.6
Grade (%):	25.9	30.2	34.2	34.2	34.3	34.3	33.7	32.2	30.7	26.2	18.2	15.0	12.2	9.7

Gear Ratios: TRN:(4) 7.26 RAX:(1) 3.08

Speed (MPH):	4.3	4.8	5.4	5.9	6.4	7.0	7.5	8.0	8.6	9.1	9.6	10.2	10.7	11.2
Grade (%):	21.8	25.4	28.6	28.6	28.7	28.7	28.2	27.0	25.7	22.1	15.3	12.6	10.3	8.1

Unpublished options may require review/approval.

Dimensional and performance data for unpublished options may vary from that displayed in PROSPECTOR.

Printed: 4/5/2019 10:17:33 AM
Effective Date: Jul 1, 2018
Prepared by: ID:wright

Complete

Model Number: Model 389
Quote/DIPO/CO: C1040010
Version Number: 37.00



Gear Ratios:	TRN:(5)	6.05	RAX:(1)	3.08															
Speed (MPH):		5.1	5.8	6.4	7.1	7.7	8.4	9.0	9.6	10.3	10.9	11.6	12.2	12.9	13.5				
Grade (%):		17.9	20.8	23.4	23.4	23.4	23.5	23.1	22.1	21.1	18.1	12.6	10.4	8.4	6.6				
Gear Ratios:	TRN:(6)	5.16	RAX:(1)	3.08															
Speed (MPH):		6.0	6.8	7.5	8.3	9.0	9.8	10.5	11.3	12.1	12.8	13.6	14.3	15.1	15.8				
Grade (%):		15.1	17.5	19.7	19.7	19.7	19.8	19.4	18.6	17.7	15.3	10.6	8.7	7.1	5.5				
Gear Ratios:	TRN:(7)	4.38	RAX:(1)	3.08															
Speed (MPH):		7.1	8.0	8.9	9.8	10.6	11.5	12.4	13.3	14.2	15.1	16.0	16.9	17.7	18.6				
Grade (%):		12.7	14.7	16.5	16.5	16.6	16.6	16.3	15.6	14.9	12.8	8.8	7.3	5.8	4.6				
Gear Ratios:	TRN:(8)	3.74	RAX:(1)	3.08															
Speed (MPH):		8.3	9.4	10.4	11.4	12.5	13.5	14.6	15.6	16.6	17.7	18.7	19.8	20.8	21.8				
Grade (%):		10.7	12.4	13.9	13.9	13.9	14.0	13.7	13.1	12.5	10.7	7.4	6.0	4.8	3.7				
Gear Ratios:	TRN:(9)	3.20	RAX:(1)	3.08															
Speed (MPH):		9.7	10.9	12.1	13.4	14.6	15.8	17.0	18.2	19.4	20.6	21.9	23.1	24.3	25.5				
Grade (%):		9.0	10.5	11.8	11.8	11.8	11.8	11.6	11.1	10.6	9.0	6.2	5.0	4.0	3.0				
Gear Ratios:	TRN:(10)	2.73	RAX:(1)	3.08															
Speed (MPH):		11.4	12.8	14.2	15.7	17.1	18.5	19.9	21.4	22.8	24.2	25.6	27.1	28.5	29.9				
Grade (%):		7.6	8.8	9.9	9.9	9.9	9.9	9.7	9.3	8.8	7.5	5.1	4.1	3.2	2.4				
Gear Ratios:	TRN:(11)	2.28	RAX:(1)	3.08															
Speed (MPH):		13.7	15.4	17.1	18.8	20.5	22.2	23.9	25.6	27.3	29.1	30.8	32.5	34.2	35.9				
Grade (%):		6.2	7.2	8.1	8.1	8.1	8.0	7.9	7.5	7.1	6.0	4.0	3.2	2.4	1.7				
Gear Ratios:	TRN:(12)	1.94	RAX:(1)	3.08															
Speed (MPH):		16.0	18.0	20.0	22.0	24.0	26.0	28.0	30.0	32.1	34.1	36.1	38.1	40.1	42.1				
Grade (%):		5.1	6.0	6.7	6.7	6.7	6.7	6.5	6.2	5.9	4.9	3.2	2.4	1.8	1.2				
Gear Ratios:	TRN:(13)	1.62	RAX:(1)	3.08															
Speed (MPH):		19.2	21.6	24.0	26.5	28.9	31.3	33.7	36.1	38.5	40.9	43.3	45.7	48.1	50.5				
Grade (%):		4.1	4.8	5.4	5.4	5.4	5.3	5.2	4.9	4.6	3.8	2.3	1.7	1.1	0.5				
Gear Ratios:	TRN:(14)	1.38	RAX:(1)	3.08															
Speed (MPH):		22.5	25.4	28.2	31.0	33.8	36.6	39.4	42.3	45.1	47.9	50.7	53.5	56.4	59.2				
Grade (%):		3.3	3.9	4.4	4.4	4.3	4.3	4.2	3.9	3.6	2.9	1.6	1.0	0.5	0.0				
Gear Ratios:	TRN:(15)	1.17	RAX:(1)	3.08															
Speed (MPH):		26.5	29.9	33.2	36.5	39.8	43.1	46.4	49.8	53.1	56.4	59.7	63.0	66.4	69.7				
Grade (%):		2.7	3.1	3.5	3.5	3.4	3.3	3.2	2.9	2.6	2.0	0.8	0.3	-0.2	-0.7				
Gear Ratios:	TRN:(16)	1.00	RAX:(1)	3.08															
Speed (MPH):		31.1	35.0	38.9	42.8	46.7	50.5	54.4	58.3	62.2	66.1	70.0	73.9	77.8	81.7				
Grade (%):		2.1	2.4	2.7	2.7	2.6	2.5	2.3	2.0	1.7	1.1	0.1	-0.5	-0.9	-1.4				
Gear Ratios:	TRN:(17)	0.86	RAX:(1)	3.08															

Unpublished options may require review/approval.
 Dimensional and performance data for unpublished options may vary from that displayed in PROSPECTOR.

Printed:	4/5/2019 10:17:33 AM	Complete	Model Number:	Model 389
Effective Date:	Jul 1, 2018		Quote/DTPO/CO:	C1040010
Prepared by:	ID:wright		Version Number:	37.00



Grade (%):	3.3	3.9	4.4	4.4	4.3	4.3	4.2	3.9	3.6	2.9	1.6	1.0	0.5	0.0
Gear Ratios:	TRN:(15)	1.17												
	RAX:(1)	3.08												
Speed (MPH):	26.5	29.9	33.2	36.5	39.8	43.1	46.4	49.8	53.1	56.4	59.7	63.0	66.4	69.7
Grade (%):	2.7	3.1	3.5	3.5	3.4	3.3	3.2	2.9	2.6	2.0	0.8	0.3	-0.2	-0.7
Gear Ratios:	TRN:(16)	1.00												
	RAX:(1)	3.08												
Speed (MPH):	31.1	35.0	38.9	42.8	46.7	50.5	54.4	58.3	62.2	66.1	70.0	73.9	77.8	81.7
Grade (%):	2.1	2.4	2.7	2.7	2.6	2.5	2.3	2.0	1.7	1.1	0.1	-0.5	-0.9	-1.4
Gear Ratios:	TRN:(17)	0.86												
	RAX:(1)	3.08												
Speed (MPH):	36.3	40.9	45.4	50.0	54.5	59.1	63.6	68.1	72.7	77.2	81.8	86.3	90.8	95.4
Grade (%):	1.5	1.8	2.0	1.9	1.8	1.6	1.4	1.1	0.8	0.2	-0.8	-1.3	-1.8	-2.3
Gear Ratios:	TRN:(18)	0.73												
	RAX:(1)	3.08												
Speed (MPH):	42.6	47.9	53.3	58.6	63.9	69.2	74.6	79.9	85.2	90.6	95.9	101.2	106.5	111.9
Grade (%):	1.0	1.2	1.3	1.1	1.0	0.8	0.5	0.1	-0.2	-0.8	-1.8	-2.3	-2.9	-3.4
Engine RPM:	800	900	1000	1100	1200	1300	1400	1500	1600	1700	1800	1900	2000	2100
Gross Torque:	1459	1666	1850	1849	1849	1849	1821	1748	1673	1455	1041	873	724	586
Net Torque:	1321	1517	1692	1693	1695	1697	1673	1606	1538	1336	952	797	659	531
Net HP:	201	260	322	355	387	420	446	459	468	432	326	288	251	212

Unpublished options may require review/approval.
 Dimensional and performance data for unpublished options may vary from that displayed in PROSPECTOR.

Printed:	4/5/2019 10:17:33 AM	Complete	Model Number:	Model 389
Effective Date:	Jul 1, 2018		Quote/DTPO/CO:	C1040010
Prepared by:	ID: ldwright		Version Number:	37.00

Additional addons for 2020 389 Peterbilt Extended Daycab for State of West Virginia

- 1. Move seat back so the back of the seat base to fire wall meets the floor is at least 48 ½ inches**
- 2. Marker lights on bottom of cab**
- 3. Minimum 24" led yellow strobe light**
- 4. Single wet line package, installed cab controlled 1 ½" quick connect fitting**
- 5. Headache rack with rear facing work lights**
- 6. License plate mounts for front bumper and rear of tractor**
- 7. Poly full fenders**
- 8. Fuel \$3.75 x 200gal**
- 9. State inspection**
- 10. Minimum 9" drop visor**

Please note that these additional addons are included into the total price of the 2020 389 Peterbilt Extended Daycab.



Martin's Peterbilt M300
174 Old Whitley Rd

389/44/40/15

London, Kentucky United States 40741

Phone: (606) 878-6410

Fax: (606) 878-2800

Email:

Phone:

Fax:

Contact Email:

Prepared for: Default Contact

Customer Quote

Equipment

Quantity Ordered:	1
Truck Price:	\$209,913
Dealer Options:	\$0
Equipment List Price:	\$209,913
Surcharges Not Subject to Discount:	\$0
Options Not Subject to Discount:	\$0
Factory Freight Cost:	\$2,425
Total Equipment Price:	<u>\$212,338</u>

NET Sale Price:

\$131,841

Miscellaneous

FET Tire Credit:	\$0
Net Chassis FET:	\$0
State Tax:	\$87
Body/Trailer/Accessories FET:	\$0
Fees:	\$0
Other:	\$0

Quotation Total:

\$131,928

Unpublished options may require review/approval.
Dimensional and performance data for unpublished options may vary from that displayed in PROSPECTOR.

Printed: 4/5/2019 10:14:35 AM
Effective Date: Jul 1, 2018
Prepared by: ID: ldwright

Complete

Model Number: Model 389
Quote/DTPO/CO: C1040010
Version Number: 37.00